



**T  
E  
C  
H  
N  
I  
C  
A  
L  
&  
R  
E  
G  
U  
L  
A  
T  
O  
R  
Y  
G  
U  
I  
D  
A  
N  
C  
E**

**TECHNICAL AND REGULATORY  
REQUIREMENTS FOR ENHANCED  
IN SITU BIOREMEDIATION OF  
CHLORINATED SOLVENTS IN  
GROUNDWATER**

**-FINAL-**

December 23, 1998

Prepared by the **Interstate Technology and Regulatory Cooperation**  
Workgroup  
*In Situ* Bioremediation Subgroup

## **ABOUT THE ITRC**

Established in 1995, the Interstate Technology and Regulatory Cooperation Work Group (ITRC) is a state led, national coalition of personnel from the regulatory and technology programs of more than 25 states, 3 federal agencies, and tribal, public, and industry stakeholders. In 1998 the ITRC and Environmental Research Institute of the States (ERIS), a nonprofit educational subsidiary of the Environmental Council of States (ECOS), signed a Memorandum of Understanding (MOU) to establish an agreement in principle for ERIS to become the host organization of the ITRC. The ITRC is devoted to reducing barriers and speeding interstate deployment of better, more cost-effective, innovative environmental technologies.

Various tools and services have been developed by the ITRC to accomplish this goal. ITRC Technical/Regulatory Guidance documents, each of which deals with a specific type of technology, enables state agencies to provide faster, more thorough reviews of permit applications and site investigation and remediation plans for full-scale deployment of such technologies. Use of these documents by states in their regulatory reviews also fosters greater consistency in technical requirements among states and results in reduced fragmentation of markets for technologies caused by differing state requirements.

Those conducting and overseeing demonstrations and verifications of technologies covered by ITRC Technical/Regulatory Guidance documents also benefit from use of the documents. By looking ahead to the typical technical requirements for permitting/approving full-scale deployment of such technologies, they can collect and evaluate information to facilitate and smooth the permitting/regulatory approval process for deployment.

The ITRC also has developed products in the categories of **Case Studies** and **Technology Overviews** (including regulatory information reports, state surveys, closure criteria documents, and formats for collection of cost and performance data); provided state input into other complementary efforts; and worked on approaches to enable state regulatory agencies to accept performance data gathered in another state as if the testing had been done in their own state.

More information about the ITRC and its available products and services can be found on the Internet at <http://www.itrcweb.org/>.

## **DISCLAIMER**

The ITRC does not endorse the use of, nor does it attempt to determine the merits of, any specific technology or technology provider through publication of any ITRC document; nor does it assume any liabilities with respect to the use of, or for damages resulting from the use of, any information, apparatus, method or process discussed in this document. Mention of trade names or commercial products does not constitute endorsement or recommendation of use. These documents are designed to help regulators and others develop a consistent approach to their evaluation, regulatory approval, and deployment of specific technologies at specific sites.

## ACKNOWLEDGMENTS

The *In Situ* Bioremediation Work Group, as part of the broader ITRC effort, is funded primarily by the United States Department of Energy. Additional funding is provided by the United States Department of Defense and the United States Environmental Protection Agency. Administrative support for grants is provided by the Western Governors Association and the Southern States Energy Board.

The following state representatives contributed to this Technical/Regulatory Guidance document: Randy Farr- Kansas, Paul Hadley - California, Bal Lee - California, Andrew Marinucci - New Jersey, Radesha Thuraisingham - Massachusetts, and Eric Trinkle - Delaware.

Representatives of federal agencies also provided technical review and assistance. They include: Arbor Drinkwine, Carol Dona, Mireck Towster, and Alan Tool - U.S. Army Corps of Engineers, Mark Goltz - Air Force Institute of Technology, Patrick Haas - Air Force Center for Environmental Excellence (AFCEE), Jim Rumbley - Maxwell AFB, Cathy Vogel - Environmental Security Technology Certification Program (ESTCP), Kathy Yager, - USEPA-Technical Innovation Office.

Members of industry and public institutions who provided technical review and assistance include: Bruce Alleman and Jeff Morse - Battelle Memorial Institute, Roger Bonner and Todd Swingle - Parsons Engineering Science, Ron Buchanan - Dupont, David Criswell - EnRisk Management Solutions, Maureen Dooley - Harding-Lawson and Associates, Steve Hill and Brent Westfall - Coleman Federal, Tim Larson - LARS Suns, Environmental Inc., Susan Litherland - Roy F. Weston, and Gale Onorato - TRW-S&ITG.

## EXECUTIVE SUMMARY

Enhanced *in situ* bioremediation (EISB) of chlorinated solvents in groundwater involves the input of an organic carbon source, nutrients, electron acceptors, and/or microbial cultures to stimulate degradation. EISB systems may be used to remediate high concentration areas within plumes or source areas, to help provide containment of a chlorinated solvent plume, or as part of a treatment train downgradient from a primary cleanup or containment system.

The major biological processes by which chlorinated solvent compounds degrade include anaerobic reductive dechlorination, aerobic cometabolism, and oxidation. Anaerobic reductive dechlorination involves the replacement of chlorine atoms in the chlorinated compound by hydrogen. An electron donor, either hydrogen gas or a precursor carbon compound, is necessary for the reduction to occur. Aerobic cometabolism involves the fortuitous degradation of chlorinated solvents by enzymes intended to metabolize compounds such as toluene, phenol, or methane. The organisms gain no benefit from the degradation, and may be harmed. Direct degradation of certain lesser chlorinated solvents can occur in either anaerobic or aerobic environments.

A key factor in the design of EISB systems is the mechanism of delivery of the various amendments to the targeted portion of the groundwater plume. Various types of delivery mechanisms have been used, including dual vertical well recirculation, horizontal well recirculation, combinations of well-infiltration trench recirculation, direct liquid amendment injection, gas amendment injection, and pass-through or reactive cell designs. Each of these may have advantages or disadvantages depending upon the major objective of the project and site conditions. For sites in which treatment of high concentration portions of a plume is the goal, systems with either dual wells or other arrangements may provide semi-closed loops which reduce downgradient flow of contaminants while providing biotreatment. For systems which are designed to reduce concentrations in portions of plumes downgradient from other remediation systems, some sort of pass-through system may be needed. These may include recirculation systems oriented at an angle to the natural hydraulic gradient, single-well recirculation systems, direct injection systems, or passive systems.

A variety of amendments may be added to EISB systems. Common carbon sources for anaerobic sites include lactic acid, sodium benzoate, methanol, and yeast extract. Common carbon sources for aerobic cometabolism sites are toluene, phenol, and methane. Most sites require nutrients, such as phosphate, nitrate, or potassium. Electron acceptors are added at some sites to promote cometabolism or direct oxidation of lesser chlorinated compounds, such as vinyl chloride. These can be added by gas injection or as a solid, such as magnesium peroxide. Naturally occurring or engineered microorganisms with specific biodegradation capabilities can be added to promote aerobic cometabolism or (less commonly) anaerobic reductive dechlorination.

EISB systems may face significant regulatory issues that require careful attention. ITRC is seeking help from regulatory agencies to help resolve some of these issues. Multiple regulatory authorities may become involved in oversight and permitting. In particular, federal and state regulations regarding the movement, treatment, and reinjection of contaminated groundwater are confusing and subject to multiple interpretations. Recirculation and reinjection of contaminated groundwater in

recirculation systems may be subject to RCRA hazardous waste and land disposal regulations. Class IV injections (hazardous waste injections into useable aquifers) for non-CERCLA and non-RCRA sites are prohibited by underground injection control (UIC) regulations.

There are potential solutions to these obstacles, including the use of Area of Contamination (AOC) and Corrective Action Management Units (CAMUs), CERCLA and RCRA permit waivers, and treatability variances. At present, there is no consensus on the best regulatory mechanism to allow reinjection to occur. It is therefore important to begin identifying permitting and other regulatory requirements and to communicate effectively with the public and stakeholder groups early in the process.

An EISB project should include a thorough initial site assessment, a laboratory treatability test, field pilot design, field pilot test, and scale-up design. The initial site assessment should accurately characterize the contaminant distribution in the area of the proposed system in both groundwater and source (if applicable). Natural attenuation parameters should be analyzed in both soil and groundwater. If necessary, the site assessment should include additional hydrogeologic study.

A laboratory treatability test should be employed at most sites. It should include either microcosm or column studies designed to show specific biodegradation mechanisms through mass determinations of parent and daughter products, and other metabolic products. The treatability test may also include direct microbial population information.

Based on the results of a successful laboratory treatability test, the field pilot should be designed to deliver amendments to the intended portion of the contaminated aquifer. All permitting and regulatory requirements should be identified and the permitting process should begin as soon as possible. The engineering design should incorporate a thorough understanding of the hydrogeology of the system. This normally includes modeling of groundwater flow, as well as transport and degradation of targeted compounds. A suitable field pilot site should be selected where the hydrogeology is fairly simple and well characterized.

Common problems encountered during operation of the field pilot include biofouling, and insufficient nutrient delivery. Biofouling can be reduced by well surging, pulsing of nutrients, and addition of high concentrations of certain electron donors or acceptors. A gradual startup of the system is recommended to determine the effective delivery rate and to reduce biofouling.

The ultimate success of the field pilot should be judged by a clearly defined loss of contaminant mass in the system, the laboratory and field evidence for specific appropriate microbial activity, and the correlation of contaminant loss with degradation parameters. Field evidence for cometabolism is more difficult than for anaerobic reductive dechlorination, and therefore cometabolism sites rely heavily on laboratory treatability studies.

## TABLE OF CONTENTS

ACKNOWLEDGMENTS .....	i
EXECUTIVE SUMMARY .....	ii
1.0 INTRODUCTION .....	1
2.0 TECHNOLOGY DESCRIPTION .....	4
2.1 Degradation Processes .....	7
2.2 Amendment Delivery Mechanisms .....	15
2.3 Amendment Requirements .....	19
2.4 When is Enhanced In Situ Bioremediation Appropriate? .....	22
3.0 REGULATORY AND POLICY ISSUES .....	23
3.1 Regulatory Authority .....	23
3.2 RCRA Land Ban Issue .....	24
3.3 Underground Injection Control (UIC) Requirements .....	27
3.4 Future Consideration for Regulatory Agencies to Address Regulatory Barriers .....	28
4.0 TECHNICAL REQUIREMENTS FOR IMPLEMENTATION OF ENHANCED IN SITU BIOREMEDIATION .....	29
4.1 Site Assessment Phase .....	30
4.2 Laboratory Treatability Test Phase .....	40
4.3 Field Pilot Test Phase .....	45
5.0 CONCLUSIONS AND RECOMMENDATIONS .....	59
6.0 REFERENCES .....	60

## LIST OF TABLES

TABLE 1	Common Chlorinated Solvents Compounds	2
TABLE 2	Summary of Some Enhanced In Situ Bioremediation Projects	5
TABLE 3	Degradation Mechanisms for Chlorinated Solvents Compounds	8
TABLE 4	Concentrations of Chlorinated Solvents in the Dover AFB Pilot	11
TABLE 5	Potential Federal Regulatory Permits and LDR Requirements	26
TABLE 6	Description of Analytical Parameters	32
TABLE 7	Guidance Documents	34
TABLE 8	Microcosm Bottle Studies	42
TABLE 9	Lines of Evidence for Performance Evaluation of Cometabolic Systems	58

## LIST OF FIGURES

FIGURE 1	Common Degradation Pathways for Chlorinated Solvents	9
FIGURE 2	Schematic Diagrams for DOVER AFB	10
FIGURE 3	Cometabolic In Situ Biodegradation System at Edwards AFB	14
FIGURE 4	Various Delivery Systems used in EISB Systems	16
FIGURE 5	Diagram of the Pinellas, FL Site	17
FIGURE 6	Steps for Implementation (by Dupont Bioremediation Team)	30
FIGURE 7	When to Consider Using In Situ Cometabolism (AFCEE)	41
FIGURE 8	Schematic of Soil Column Set-up	43
FIGURE 9	Hydrogeologic Model of a Dual-Well In Situ Bioremediation Recirculation System	49
FIGURE 10	Effects of Increasing Extraction/Injection Rate in a Dual-Well Recirculation System	50
FIGURE 11	Loss of Plume Containment from Excessive Pumping in a Dual-Well Recirculation System	51
FIGURE 12	Hydrogeologic Model using a Dual Well Recirculation System	52
FIGURE 13	Hydrogeologic Model of Vertical Recirculation System	53
FIGURE 14	ESTCP Protocol Test Plot Layout	55
FIGURE 15	System Configuration for Bioaugmentation Study - Schoolcraft, Michigan	57

## **APPENDICES**

APPENDIX AITRC Work Team Roster/Contacts

APPENDIX B Acronyms

APPENDIX C Six States Regulatory Surveys (1997)

APPENDIX D Case Study Response

APPENDIX E Regulatory Issues and Solutions

APPENDIX F State Class V Permit Example

APPENDIX G State Underground Injection Control program Survey (1998)



# TECHNICAL AND REGULATORY REQUIREMENTS FOR ENHANCED *IN SITU* BIOREMEDIATION OF CHLORINATED SOLVENTS IN GROUNDWATER

## 1.0 INTRODUCTION

The Interstate Technology and Regulatory Cooperation (ITRC) Work Group, established in 1995, is a state-led partnership between state environmental regulatory agencies, federal agencies, tribal, public and industry stakeholders. The purpose of the ITRC is to improve environmental cleanup by encouraging the use of innovative technologies, while reducing regulatory paperwork and overall costs. States are collaborating to develop and facilitate the use of standardized processes for the performance verification of new technologies.

This project was initiated by the *In Situ* Bioremediation (ISB) Team of the ITRC in order to provide guidance to those considering the deployment of enhanced *in situ* bioremediation (EISB) of chlorinated solvents in groundwater. It represents a continuation of earlier efforts by the ISB team, including the 1996 ITRC document *Case Studies of Regulatory Acceptance of ISB Technologies*, as well as an unpublished draft report in 1997, *An Analysis of State Regulatory and Policy Issues Regarding the Implementation of In Situ Bioremediation of Chlorinated Solvents*, which compiled regulatory and policy information from six states concerning three classes of ISB technologies. The 1997 report alerted our team to the existence of significant regulatory barriers to the implementation of this technology and a lack of clear technical and regulatory guidance.

This document deals specifically with classes of remediation systems designed to remediate or prevent further migration of chlorinated solvents in groundwater through the use of enhancements, to the natural subsurface environment, to accelerate the biodegradation of chlorinated solvents. Chlorinated solvents include aliphatic compounds in which one or more hydrogens have been replaced with chlorine. They are produced in large quantities and used primarily for cleaning, degreasing, grain fumigation, and fuel additives. Chlorinated compounds that potentially may be addressed by this technology are listed in Table 1.

The primary purpose of the document is to provide sufficient technical and regulatory information to make informed decisions on whether to proceed with EISB pilot studies. Therefore, the primary intended audience is state and federal regulators who are currently considering this technology for a particular site. It is not intended to provide all of the technical information necessary to install these systems. It is assumed that those performing the pilot studies are experienced in the technology. However, contractors, responsible parties, and vendors may find this document useful, because it will provide explanation and insight into the types of information they will likely be asked to provide to regulators.

The Air Force Research Laboratory, Battelle Memorial Institute, Cornell University, the U.S. EPA and the Air Force Armstrong Laboratory have developed a draft technical protocol document through the Environmental Security Technology Certification Program (ESTCP) of the Department of Defense which details their approach for implementing one type of EISB, it is titled A Treatability

Table 1. List of Common Chlorinated Solvents.

Compounds	Abbreviation	Formula
<i>Chlorinated Methanes</i>		
Carbon tetrachloride	CT	CCl <sub>4</sub>
Chloroform	CF	CHCl <sub>3</sub>
Methylene Chloride Dichloromethane	DCM	CH <sub>2</sub> Cl <sub>2</sub>
Chloromethane	CM	CH <sub>3</sub> Cl
<i>Chlorinated Ethenes</i>		
Perchloroethylene or Tetrachloroethylene	PCE	C <sub>2</sub> Cl <sub>4</sub>
Trichloroethylene	TCE	C <sub>2</sub> HCl <sub>3</sub>
Trans 1,2- Dichloroethylene	tDCE	C <sub>2</sub> H <sub>2</sub> Cl <sub>2</sub>
Cis 1,2-Dichloroethylene	cDCE	C <sub>2</sub> H <sub>2</sub> Cl <sub>2</sub>
1,1-Dichloroethylene	1,1-DCE	C <sub>2</sub> H <sub>2</sub> Cl <sub>2</sub>
Vinyl chloride	VC	C <sub>2</sub> H <sub>3</sub> Cl
<i>Chlorinated Ethanes</i>		
1,1,1,2- Tetrachloroethane	PCA	C <sub>2</sub> HCl <sub>4</sub>
1,1,1-Trichloroethane	1,1,1-TCA	C <sub>2</sub> H <sub>3</sub> Cl <sub>3</sub>
1,1,2-Trichloroethane	1,1,2-TCA	C <sub>2</sub> H <sub>3</sub> Cl <sub>3</sub>
1,1-Dichloroethane	1,1-DCA	C <sub>2</sub> H <sub>4</sub> Cl <sub>2</sub>
1,2-Dichloroethane	1,2-DCA	C <sub>2</sub> H <sub>4</sub> Cl <sub>2</sub>
Chloroethane	CA	C <sub>2</sub> H <sub>5</sub> Cl

---

Test for Evaluating the Potential Applicability of the Reductive Anaerobic Biological In Situ Treatment Technology (RABITT) to Remediate Chloroethenes (Morse et al., 1998). It describes a comprehensive approach for conducting a phased treatability study to determine the potential for employing RABITT. This protocol focuses upon anaerobic reductive systems. It does not address other types of biodegradation types, such as aerobic cometabolism or oxidation. Also, it is not meant to function as a protocol for implementing larger-scale pilot studies or full-scale bioremediation systems. The ESTCP Protocol, as of this writing, has not been validated. The protocol will be conducted at five Department of Defense contaminated sites over the following two years. After evaluation of the laboratory and field data generated from the five sites, the protocol will be revised as needed and peer-reviewed prior to publishing as a final document. Until this process is completed, a copy of this protocol can be obtained by contacting Cathy Vogel at (703) 696-2118 or via email [vogelc@acq.osd.mil](mailto:vogelc@acq.osd.mil). In addition, the Dupont bioremediation technology team is in the process of developing a protocol/document of recommendation for implementing anaerobic reductive bioremediation projects at their chlorinated solvent sites (Beeman et al., 1998).

A guidance document for a class of EISB of chlorinated solvents in groundwater known as aerobic cometabolism, has been produced by the Installation Restoration Program (IRP) of The Air Force Center For Environmental Excellence (Air Force Center for Environmental Excellence, 1997). This document is entitled Aerobic Cometabolic In Situ Bioremediation Technology Guidance Manual and was available, at the time that this report was drafted, from the World Wide Web at <http://en.afit.af.mil/env/insitubio.htm>.

Both the ESTCP and Dupont protocols/recommendations deal with anaerobic reductive bioremediation systems. These types of systems are the most common in the U.S., and our work team members have more experience with these types of systems. Other major classes of EISB systems, which rely on aerobic cometabolism or aerobic oxidation of chlorinated solvents, are discussed in the document as well. Although the document provides more information for anaerobic reductive systems, it is not meant as an endorsement of one type of EISB system over another. The selection of an appropriate bioremediation technology should be based on many site specific factors including hydrogeologic conditions, aquifer geochemistry, indigenous microbial activity, and the nature of the contamination.

This document does not specifically address *in situ* bioremediation of other classes of compounds in groundwater, such as petroleum hydrocarbons, chlorinated aromatic compounds, nitrates, or metals. However, in many cases the design of EISB for these other compounds may be very similar to those described in this document. Therefore, those considering *in situ* bioremediation systems for these other compounds may find this document to be useful.

This document does not specifically address requirements for the implementation of natural attenuation of chlorinated solvents. However, EISB has been referred to as “engineered natural attenuation”, and the requirements for baseline site characterization for *in situ* bioremediation is very similar to that required for an evaluation of natural attenuation. In most cases, natural attenuation may be a measurable part of the treatment system for a site in which enhanced *in situ* bioremediation has been selected as a remedy.

---

In addition to the ESTCP, Dupont, and AFCEE protocols, the reader is referred to *Bioremediation Engineering Design and Application* by John T. Cookson (Cookson, 1995) which contains two very useful chapters (Chapters 6 and 7) on the site characterization and design of *in situ* bioremediation systems. While the book predates many of the current *in situ* bioremediation designs for chlorinated solvents, the engineering approaches to amendment delivery are very similar to most current or proposed systems.

## 2.0 TECHNOLOGY DESCRIPTION

This class of remediation technology is fairly new, especially for chlorinated solvents. The first successful pilots were conducted in the late 1980s and early 1990s (i.e. Semprini et al., 1990; Gibson and Sewell, 1992; Cox and Major, 1993). At this point, there are few full scale projects, so most experience is in the design of smaller scale pilot systems. However, the number of EISB projects has grown significantly and currently accounts for about \$200 to \$250 million in expenditures, according to Glass et al. (1997).

Microbial populations involved in bioremediation require a source of carbon, an electron donor, an electron acceptor, appropriate nutrients, a suitable temperature range, pH, and other environmental conditions. Very often the carbon source serves as the electron donor. EISB systems stimulate the biodegradation of chlorinated solvents by manipulating these requirements in the subsurface. Some systems further stimulate biodegradation by adding naturally-occurring or engineered microorganisms that are particularly suited to biodegradation of chlorinated solvents. This process is known as bioaugmentation.

There are several different designs of EISB systems for groundwater which use various delivery mechanisms, degradation mechanisms, and nutrient or biological amendments. The appropriateness of a particular type of delivery, degradation, or amendment system will vary from site to site and will depend on the goal of the proposed project. In some cases, the goal of the system will be to provide treatment to a chlorinated solvent plume while at the same time preventing offsite migration or to protect a receptor. The ability of the EISB system to provide hydraulic control will often be an important consideration in this type of system. Other systems may be intended to serve as a “polishing stage”, usually located downgradient from the primary remedial or containment technology. Economic delivery of inexpensive amendments may be more critical than hydraulic containment for these types of systems. Still other systems will focus upon biodegradation of chlorinated solvents in groundwater within the source area or hot spots within the plume. Source or hot-spot treatment systems may require highly engineered delivery systems in order to ensure sufficient treatment of the targeted portions of the plume.

Research is currently ongoing in the DoD and private sector to evaluate the effectiveness of EISB and bioaugmentation for source zone treatment. In fact, some studies have suggested that EISB may be an effective treatment technology for DNAPL sources (i.e. Nielson and Keasling, 1998). For these systems, the degradation would occur in the dissolved phases immediately adjacent to the DNAPL sources. However, other studies suggest that there may be significant toxic effects on degradation at very high dissolved concentrations.

Table 2. Summary of some enhanced *in situ* bioremediation projects segregated by delivery systems, degradation mechanisms, and amendments.

	<b>Class of Degradation Mechanism</b>	
	<b>Reductive Anaerobic Dechlorination</b>	<b>Aerobic Cometabolism and Oxidation</b>
<b>Class of Delivery System</b>		
<b>Dual Vertical Well</b>	Dover AFB (3)	Wichita, KS (19,20)
	Fallon AFB, Nevada (1)	The Netherlands (13)
	Gulf Coast, Texas (22)	Moffett AFB (24)
	The Netherlands (13)	Schoolcraft, MI (18)
	Merced, Ca (21)	Arizona (7)
	Niagara, New York (22)	
	Ontario (2)	
	Port Mugu Naval AS, CA (5)	
	Texas Gulf Coast (11)	
	Airport, Oklahoma (14)	
	Victoria, TX (22)	
	Watertown, MA (4, 29)	Watertown, MA (4)
<b>Dual Recirculating Wells</b>		Edwards AFB, CA (15,23)
<b>Dual Horizontal Well</b>	Pinellas, FL (6, 10)	
<b>Gas Injection - Horizontal Wells</b>		Savannah River, SC (8)
		Hastings, NE (7)
<b>Gas Injection - Vertical Wells</b>		Virginia (25)
	Williamsport Pennsylvania (13)	
<b>Amendments</b>		
Sodium Lactate, Lactic Acid	Pinellas, FL, STAR Facility (6, 10)	
	Dover AFB (3)	
	Watertown, MA (4)	
	Fallon AFB, Nevada (1)	
Methane		Hastings, NE (7)
		Savannah River DOE Facility, SC (8)
		Moffett AFB (24)
		Indiana (28)
		Virginia (26)
Phenol		The Netherlands (13)
		Edwards AFB, CA (15)
Toluene		Edwards AFB, CA (15,23)
		Moffett AFB (24)
		Chico, CA (27)

Table 2 (Continued)	Anaerobic Reduction	Cometabolic
<b>Amendments (Continued)</b>		
Benzoate	Pinellas, FL STAR Facility (6, 10)	
	Landfill, Victoria, TX (22)	
	Alliston , Ontario (16)	
	Fallon AFB, Nevada (1)	
Methanol	Pinellas, FL, STAR Facility (6, 10)	Arizona (7)
	Texas Gulf Coast (11)	
	The Netherlands (13)	
	Merced, CA (21)	
	Airport, Oklahoma (14)	
Ethanol	Fallon AFB, Nevada (1)	
Disaccharide	San Francisco Bay Area, CA (9)	
Mollasses	Eastern PA (12)	
	Williamsport Pennsylvania (12)	
Yeast Extract	Niagara, New York (22)	
	Watertown, MA (4)	
	Gulf Coast, Texas (22)	
	San Francisco Bay Area, CA (9)	
	Fallon AFB, Nevada (1)	
Vanillin		Arizona (7)
Acetate		Schoolcraft, MI (18)
Glucose		Wichita, KS (19, 20)
Vitamin B12-Citric Acid	Fallon AFB, Nevada (1)	
Hydrogen Peroxide		Edwards AFB, CA (15,23) Arizona (7)
Magnesium peroxide (Oxygen Release Compound or ORCJ )		Watertown, MA (29) Northern Minnesota (26)
Hydrogen Release Compound (HRCJ - a polylactate ester)	Watertown, MA (29)	
<b>Bacterial Augmentation</b>	Dover AFB (3)	Chico, CA (27)
		Schoolcraft, MI (18)
		Wichita, KS (19, 20)

(1) Becvar et al. (1998); (2) Cox et al. (1998); (3) Pardieck et al. (1997); (4) Lewis et al. (1998); (5) Jerger et al. (1998); (6) Sewell et al. (1998); (7) LaPat-Polasko et al. (1998); (8) Hazen et al. (1997); (9) Honniball et al. (1998); (10) Weesner et al. (1998); (11) Litherland et al. (1997); (12) Nyer et al. (1997); (13) Spuij et al. (1997); (14) Christopher et al. (1997); (15) Tovanobootr et al. (1997); (16) Brown et al. (1997); (17) LaPat-Polasko and Lazarr (1997); (18) Criddle et al. (1997); (19) Bourquin et al. (1997); (20) Malusis et al. (1997); (21) Cox et al. (1993); (22) Beeman et al. (1998); (23) McCarty et al. (1998); (24) Semprini et al. (1990); (25) Legrand et al. (1998); (26) Verhagen et al. (1998); (27) Duba et al., 1996; (28) Scanke et al. (1997); (29) Harding Lawsons Associates, 1998.

---

---

## 2.1 Degradation Processes

Most of the EISB systems for chlorinated solvents in the United States rely on one of two major degradation mechanisms (Table 2): reductive anaerobic dechlorination or aerobic cometabolism. A few systems rely on oxidation reactions, usually for the destruction of vinyl chloride. Most systems that use oxidation as a biodegradation mechanism, do so as a polishing step after reductive anaerobic biodegradation.

### 2.1.1 Reductive Anaerobic Dechlorination

All of the chlorinated solvent compounds in Table 3 can undergo reductive dechlorination in anaerobic environments (Tables 3; Fig. 1). Recent research shows that certain microbes (halorespirers) can “respire” the chlorinated solvents in the same manner that aerobic organisms respire oxygen (i.e. Maymo-Gatell et al., 1995; Lee et al., 1998). In this reaction, the chlorinated compound can serve as an electron acceptor in place of a normal acceptor, such as nitrate or sulfate. Cometabolic reductive dehalogenation, in which chlorinated solvents are incidentally reduced in the presence of methanogens or sulfate reducing bacteria without metabolic benefit, can occur. However recent research suggests that at most chlorinated solvent sites, the activity of true halorespirers may be more important (Lee et al., 1998). Cometabolic reduction of chlorinated solvents may be important in intensely reducing environments, such as landfills (Lee et al., 1998).

Anaerobic reduction involves the substitution of H<sup>+</sup> for Cl in the chlorinated solvent structure (R-Cl in the equation below).

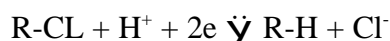

Chlorinated solvents undergo a series of reductions through dechlorination reactions. For example, perchloroethylene (PCE) degrades to trichloroethylene (TCE), which degrades primarily to cis 1,2-dichloroethylene (cDCE), which in turn degrades to vinyl chloride (VC), which is dechlorinated to ethene. Each step requires a lower redox potential than the previous one. PCE degradation occurs in a wide range of reducing conditions, whereas VC is reduced to ethene only under sulfate reducing and methanogenic conditions. During each of these transformations, the parent compound (R-Cl) releases one chloride ion and gains one hydrogen. Two electrons are transferred during the process, which may provide a source of energy for the microorganism. The ultimate source for the hydrogen and electrons in this reaction is some sort of organic substrate. Hydrogen (H<sub>2</sub>) is released during fermentation of the substrate. The hydrogen (H<sub>2</sub>) liberated from this substrate acts as the actual electron donor for respiration (i.e. DiStefano et al., 1991; Newell et al., 1998). Complete reductive dechlorination was first documented in the laboratory by Freedman and Gossett (1989) and in the field by Major and Cox (1992).

A majority of EISB systems for chlorinated solvents use the reductive anaerobic dechlorination mechanism to degrade chlorinated solvents. Morse et al. (1998) in the ESTCP Protocol, refer to these systems as “reductive anaerobic biological *in situ* treatment technology” (RABITT). An example of such a system is the pilot demonstration at Dover AFB, Delaware, which is being

**Table 3.** Degradation mechanisms for chlorinated solvents compounds. Modified from Remedial Technologies Development Forum (1998) and McCarty (1994).

Process	PCE	TCE	cDCE	VC	TCA	1,1-DCA	CT	CF	DCM
Direct Aerobic	N	N	Y&N	Y	N	N	N	N	Y
Cometabolic with CH <sub>4</sub>	N	Y	Y	Y	Y&N	Y&N	N	Y	Y
Cometabolic with toluene	N	Y	Y	Y	N	Y&N	N	N*	NR
Cometabolic with NH <sub>4</sub> <sup>+</sup>	N	Y	Y	Y	Y	N*	N	Y	NR
Direct Anaerobic	N	N	Y*	Y*	Y*	N	N	N	Y
Anaerobic / Denitrification	Y&N	Y&N	N*	N*	N*	Y&N	Y	Y&N	NR
Anaerobic / Sulfate-reduction	Y	Y	Y	Y	Y	Y	Y	Y	NR
Anaerobic / Methanogenic	Y	Y	Y	Y	Y	Y	Y	Y	NR

N: Not documented in the literature

Y: Documented in the literature many times; consensus opinion

Y\*: Fe - reducing conditions for VC, Mn - reducing conditions for cis-DCE

Y&N: Documented in the literature more than once of both occurrence and absence

N\*: Not documented in the literature to date, but not investigated significantly

NR: Process may occur but "Not Relevant" since competing process occurs more rapidly

conducted by the Remedial Technologies Development Forum (Fig.2). Trichloroethylene (TCE) and dichloroethylenes (primarily cDCE) are the major contaminants of concern. The ultimate goal for this system is to reduce contaminant levels in high concentration portions of the plume near the source areas. The system includes three extraction-injection wells approximately 20 feet (6 m) apart and three injection wells 60 feet (18 m) upgradient from the extraction wells, resulting in three recirculation cells oriented approximately parallel to groundwater flow (Fig. 2). The contaminated aquifer is a sandy alluvial aquifer with a hydraulic conductivity of approximately 0.021 cm/s and flow velocity of about 1ft<sup>3</sup>/day. Initial TCE concentrations ranged from 5 to 10 mg/L, while DCE ranged from 1 to 2 mg/L (Table 4). In the initial phase of study, contaminated groundwater was pumped from the three downgradient extraction wells at a rate of approximately 1.2 gpm and reinjected into the upgradient wells at the same rate. Lactic acid or sodium lactate, as well as nutrients (phosphate and ammonium nitrate) were added at intervals of 2.75 to 3.75 days. Operation of this system resulted in substantial dechlorination of TCE to cDCE over a period of about 50 days.



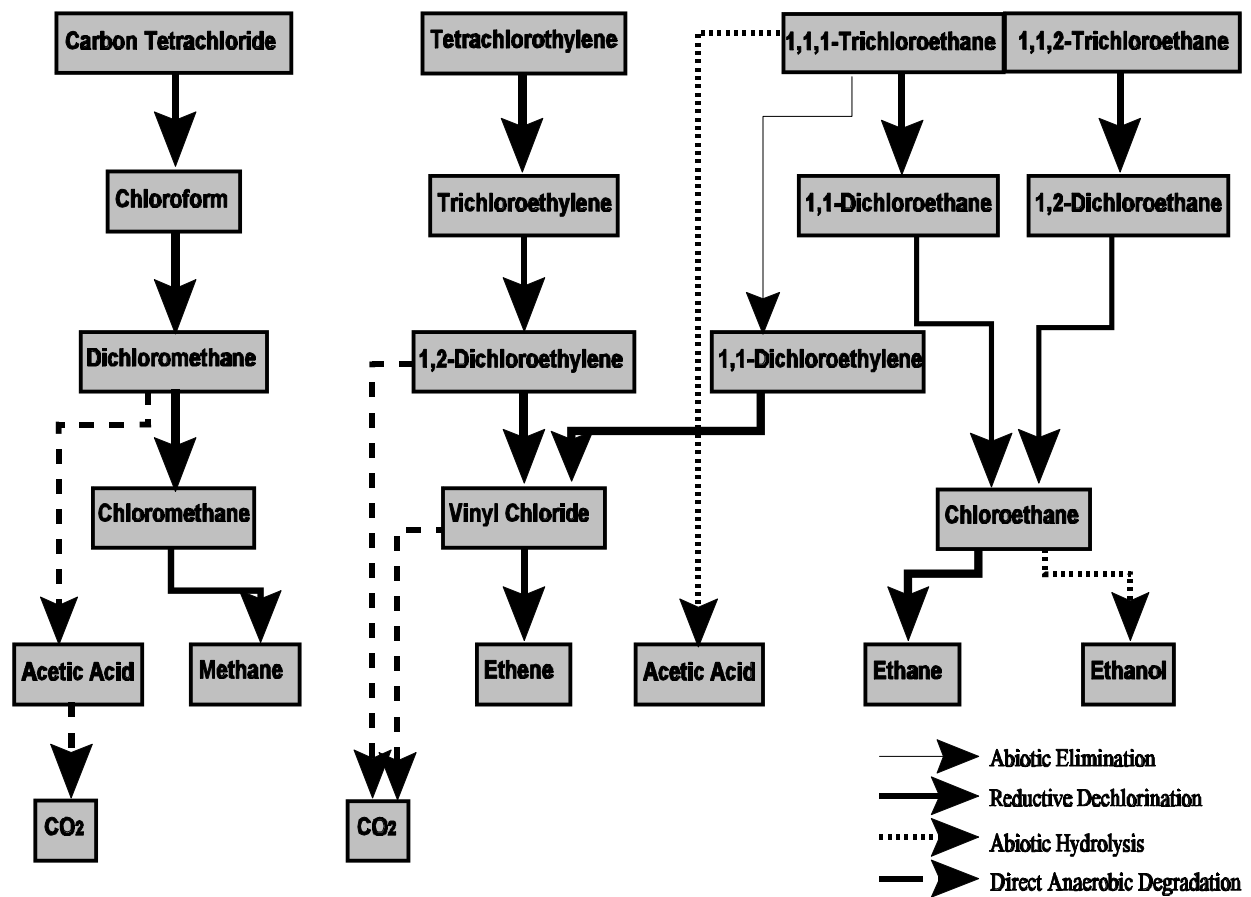

Figure 1. Common degradation pathways for chlorinated solvents. Modified from Beak International, Inc. (1997) with supplementary information from Bradley and Chappelle (1997).

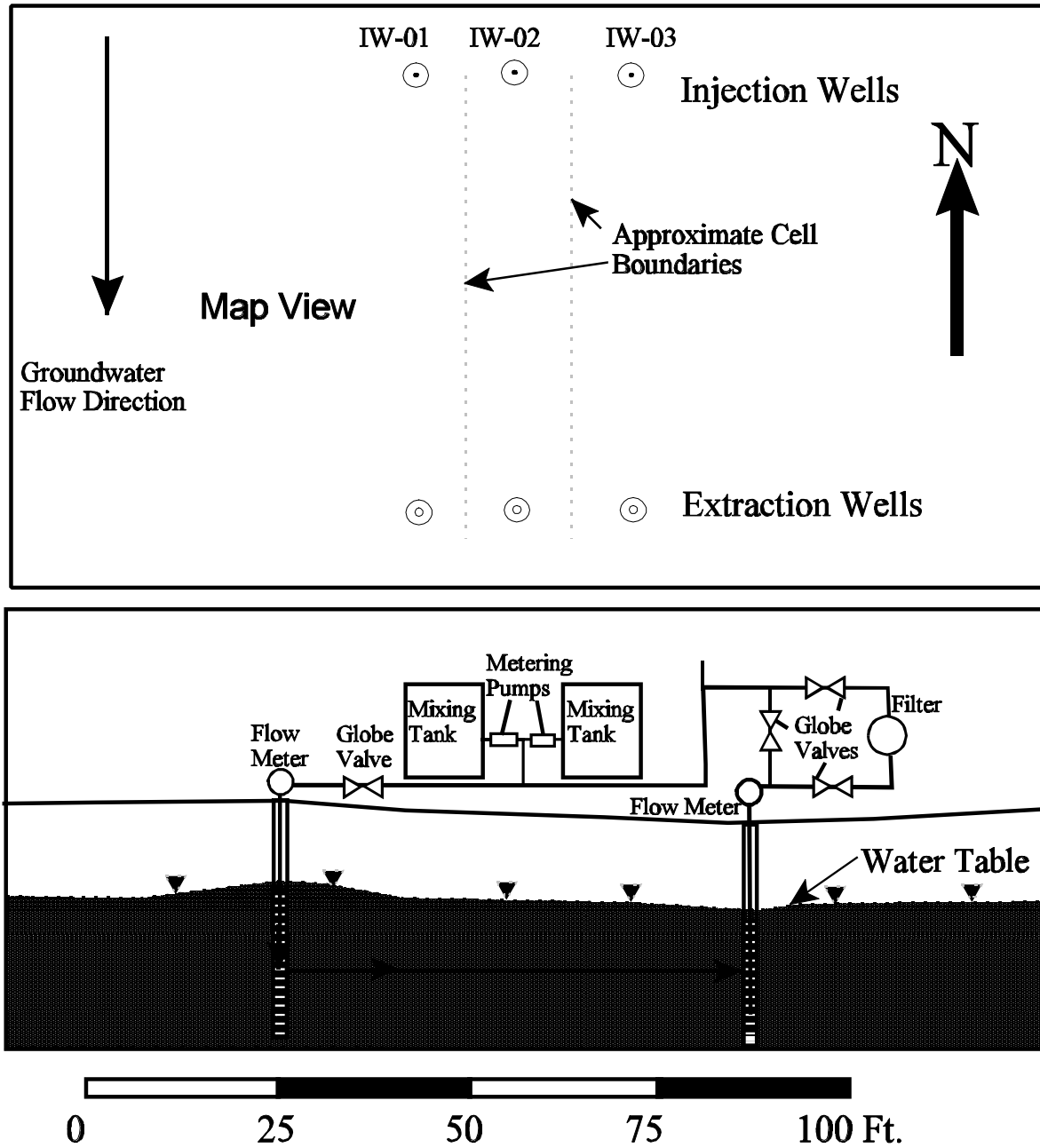

Figure 2. Schematic diagrams of the anaerobic in situ bioremediation pilot at Dover Air Force Base. Modified from RTDF (1997).

**Table 4.** Initial and final concentrations of chlorinated solvents in the Dover Air Force Base anaerobic in situ biodegradation pilot.

Cell	Contaminant	Concentration (mg/L)	Comments
<b>Initial Average Concentrations</b>	TCE	4700	Average for all three cells.
	cDCE	1200	
	VC	<90	
	Ethene	<5	
<b>Inner Cell (IW2) Final Concentrations</b>	TCE	<1	Cell in which Pinellas, FL bacterial culture was added.
	cDCE	<1	
	VC	<1	
	Ethene	790	
<b>West Cell (IW1) Final Concentrations</b>	TCE	<1	VC and Ethene production and degradation were much later than in Inner Cell.
	cDCE	2.9	
	VC	1.6	
	Ethene	770	
<b>East Cell (IW3) Final Concentrations</b>	TCE	2.7	VC and Ethene production and degradation were much later than in Inner Cell.
	cDCE	3.2	
	VC	<1	
	Ethene	690	

However, after this period, there was little change in DCE concentrations, and no observed production of the cDCE degradation product VC.

Following this initial phase of development, the RTDF team introduced a naturally-occurring bacterial culture from a contaminated chlorinated solvent site at Pinellas, Florida as an amendment to the middle recirculation cell. This culture had been shown in laboratory studies to effectively dechlorinate TCE to ethene in Dover AFB samples. Within 3 months of operation, after the addition of the bacterial amendment, all of the monitoring points within the inner cell had experienced a conversion of cDCE to VC, and finally to ethene. The two outer cells also experienced a delayed conversion of cDCE to VC well after this reaction was observed in the inner cell, followed by almost complete conversion of VC to ethene (Table 4). This delayed degradation in the outer cells was apparently due to the gradual lateral population growth of the introduced culture. The initial rapid conversion of cDCE to VC and finally to ethene in the inner cell, in which bacteria were introduced, suggests that the bacteria were the main cause for cDCE and VC degradation.

Anaerobic reductive dechlorination systems have proven to be effective, at least in smaller scale applications. In many cases, they are relatively inexpensive to operate and the amendments involved are typically not of concern to regulators. However there are some potential problems, including:

- Degradation rates may be slow, especially for the less chlorinated ethenes and ethanes.
- Biofouling may cause loss of injection wells and reduced circulation.

- Abundant electron acceptors, such as sulfate, may inhibit reductive biodegradation.
- Underground Injection Control and RCRA regulations and restrictions may apply when groundwater is recirculated (See Section 3.0).

These issues will be addressed individually in this document.

### 2.1.2 Aerobic Cometabolism

Aerobic cometabolism of chlorinated solvents is a fortuitous reaction in which bacteria produce non-specific oxygenase enzymes designed to metabolize substrates such as toluene, phenol, or methane (Wackett and Gibson, 1988). These enzymes require molecular oxygen and incidentally oxidize some of the chlorinated compounds. The bacteria involved in this degradation do not benefit, and often are harmed by the intermediate compounds that are formed. For this reason, aerobic cometabolism systems may involve some augmentation of native bacterial populations with non-native or engineered bacterial cultures (i.e. Duba et al., 1996; Munakata-Marr et al., 1998). The process of aerobic cometabolism has been shown to be a viable degradation process for TCE, 1,2-DCE, VC, and chloroform (CF). Highly chlorinated compounds such as PCE and carbon tetrachloride (CT) do not appear to be susceptible to cometabolic degradation (Table 3; i.e. Nelson et al., 1988; McCarty et al., 1990; Roberts et al., 1990; Hopkins et al., 1993). 1,1-DCE may degrade cometabolically, but at even low concentrations (>16 µg/L) it may inhibit degradation of other chlorinated solvents through a toxic effect (Dolan and McCarty, 1995).

Work in the 1980s and 1990s by Wilson and Wilson (1985), Wackett et al. (1989) and McCarty, Semprini, and coworkers (e.g. McCarty et al., 1990, 1991; Semprini et al., 1990), established the viability of aerobic cometabolism of certain chlorinated solvents. Two major groups of cometabolic systems have been evaluated. A group that includes workers from E.O. Lawrence Berkeley National Laboratory, Radian International, Westinghouse Savannah River Laboratories, and the U.S. Army Corps of Engineers are working on several projects involving the direct injection of methane gas with assorted nutrients (i.e. Hazen et al., 1997; Legrand et al., 1998; LaPat-Polasko et al., 1998). This technology is referred to as methanotrophic treatment technology (MTT) and is often used as a polishing step in combination with soil vapor extraction or air sparging. Another group that includes workers from Stanford University and Oregon State University focuses on the recirculation of groundwater with the addition of phenol, toluene, or other primary substrates, an oxygen source and various other nutrients (i.e. McCarty et al., 1990, 1991, 1998; Semprini et al., 1990).

The first published aerobic cometabolism field study was at Moffett Federal Airfield, California (Semprini et al., 1990). This study used methane as the primary substrate and oxygen gas as the source of oxygen for aerobic cometabolism of TCE, 1,2-DCE, and VC. Primary contaminants were TCE (45-250 µg/L) and cDCE (100-125 µg/L). Semprini et al. (1990) determined that methane was most effective at removing the lesser chlorinated compounds, but not as effective in removing TCE. A later study at Moffett Federal Airfield used phenol as the substrate (Hopkins et al., 1993). This study showed better success in reducing TCE concentrations, achieving final TCE concentrations of approximately 25 µg/L and cDCE concentrations of about 11 µg/L.

Results from the Moffett Federal Airfield study led to a follow-up effort which used toluene as the cosubstrate at Edwards AFB, California (McCarty et al., 1998). Groundwater contaminated with

---

500-1200 µg/L trichloroethylene (TCE) was treated *in situ* over a 410-day period by aerobic cometabolism through injection of 7-13.4 mg/L toluene, oxygen, and hydrogen peroxide. Groundwater was circulated between two contaminated aquifers through two treatment wells located 10 m apart (Fig. 3). One well pumped contaminated groundwater from the 8 m thick upper aquifer to the 5 m thick lower aquifer, while the other pumped contaminated water from the lower to the upper aquifers using flow rates of 25-38 L/min, affecting groundwater circulation between them (Fig. 3). The field demonstration at Edwards resulted in 95% to 98% reduction in TCE to a concentration of approximately 30 µg/L. Toluene degradation was 99.98%, leaving 1.2 to 1.3 µg/L at the boundaries of the treatment zone.

A current example of a full-scale evaluation of *in situ* aerobic cometabolism through methane and oxygen introduction is at the Former Naval Ammunition Depot in Hastings, Nebraska, which uses the MTT approach. The cometabolic system is used in conjunction with air sparging and soil vapor extraction as a “polishing” step. Methane is applied at concentrations of 4 percent and induces production of the enzyme methane mono-oxygenase, and serves to act as an electron donor. The methane is introduced via a horizontal well. This technology has also been applied at Savannah River, South Carolina (DOE facility), and through vertical wells at a natural gas pumping station in Virginia (Legrand et al., 1998).

Degradation rates may be quite high in cometabolic systems, and many contaminated aquifers are already aerobic and therefore do not require extensive oxidation-reduction potential modification. It is also sometimes easier to inject gasses, rather than liquids. Because some of these systems do not require the recirculation of contaminated groundwater, Underground Injection Control (UIC) permits and RCRA hazardous waste issues may not be a problem. Potential disadvantages to the cometabolic systems include the lack of degradation of highly chlorinated compounds, competitive inhibition between cosubstrates, and the relatively high cost of maintaining aerobic conditions in some systems (Becvar et al., 1997). Also, some degradation products have mutagenic and hepatocarcinogenic properties. These include dichloroacetic acids, trichloroacetic acid, and chloral (Cookson, 1995). However, these products are generally not stable in groundwater. Toluene and phenol, which are two of the more common substrate amendments, are also both RCRA regulated compounds.

### 2.1.3 Oxidation and Direct Degradation

Chlorinated solvents such as dichloromethane (DCM), VC, chloroethane (CA), and chloromethane (CM) are susceptible to direct oxidation in aerobic environments (Fig. 1; Table 3). It has been known for some time that DCM can also undergo direct degradation in an anaerobic environment forming acetic acid. It has recently been shown that VC and 1,2-DCE can be directly degraded as electron donors in anaerobic environments under certain conditions. For example, Bradley and

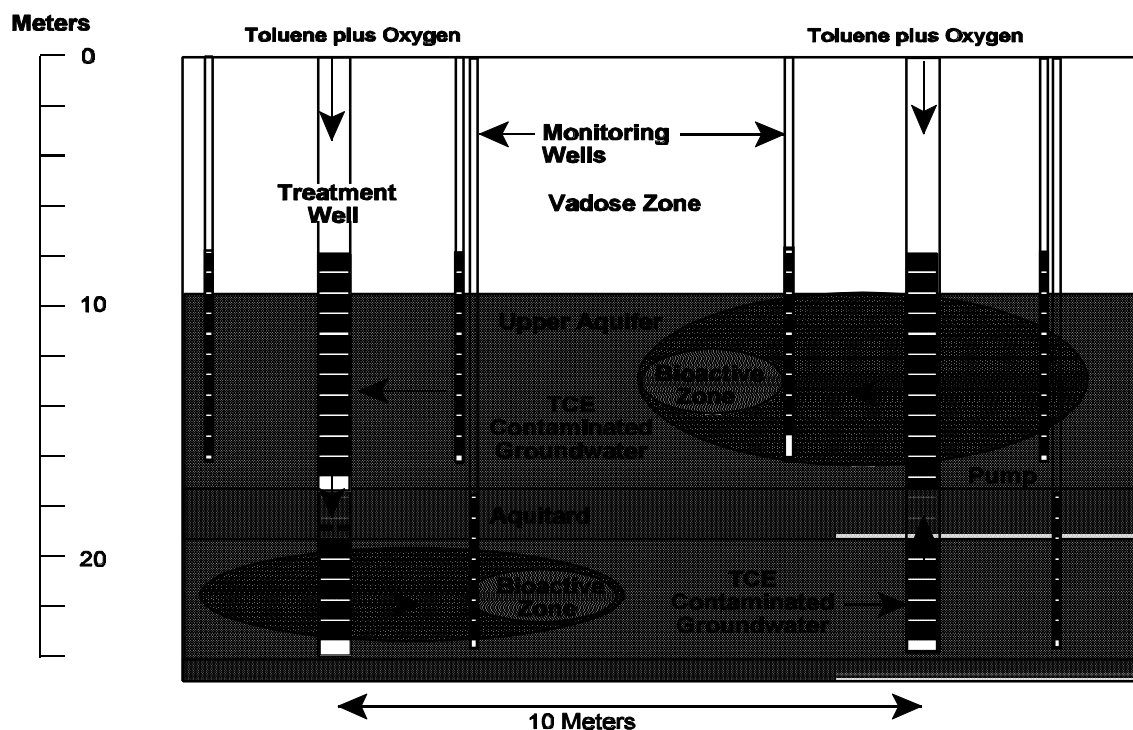

Figure 3. Concept for In Situ Aerobic Cometabolic Bioremediation Demonstration at Edwards AFB. Modified from McCarthy et al., (1998).

Chapelle (1996, 1997) showed that in the presence of chelated Fe(III), VC can be completely converted to CO<sub>2</sub>, chloride, and water. In addition, Bradley and Chapelle (1997) conclude that degradation of 1,2-DCE will also occur in the presence of Mn(IV) or Fe(III).

EISB may stimulate oxidation in aerobic systems by supplying oxygen directly or indirectly through some other compound. Lewis et al. (1998), describe a system in Watertown, Massachusetts in which reductive dechlorination resulted in production of DCE and VC which were then treated aerobically using a patented substance called Oxygen Release Compound (ORC™). The anaerobic-aerobic treatment can be conducted in series spatially, or temporally. A second pilot which used Hydrogen Release Compound (HRC™) was conducted, and as of the time of this writing, VC degradation to ethene through reductive dechlorination had been documented (Koenigsberg et al., 1998; Harding Lawson Associates, 1998).

A pilot in Northern Minnesota (Verhagen et al., 1998) also used ORC™ treatment to reduce VC levels. Degradation was enhanced downgradient of the site, but not at the site itself. The enhancement was restricted to a two month period. Removal of the ORC™-containing socks after the pilot revealed significant iron precipitates. These may have prevented the generation and release of oxygen. In addition, very high hydraulic conductivities may also have caused the ORC™ material to be rapidly consumed.

---

Oxidation of VC and other chlorinated solvents in aerobic systems may be quite rapid and complete. A potential problem with this approach is the difficulty in delivering oxygen, hydrogen peroxide, or oxygen via ORC™ to the targeted portion of the plume. Aquifers with low hydraulic conductivities, or high naturally occurring organic carbon may be particularly difficult to remediate using this approach. Aquifers with very high hydraulic conductivities may require very large quantities of oxidants.

## **2.2 Amendment Delivery Mechanisms**

One of the requirements for EISB is the effective delivery of the required amendments to the targeted portion of the plume. There are a number of different delivery systems which use either active or passive delivery of amendments.

All of the systems discussed have reported success in delivering amendments within the pilot or full scale systems being considered. However, the rate that amendments are delivered, and whether they reach lower hydraulic conductivity zones is often not properly evaluated. Effective delivery is absolutely critical to successful degradation. Incomplete delivery may result in pockets of persistent intermediate degradation products such as cDCE and VC. However, as previously noted, these two compounds, and VC in particular, are susceptible to multiple natural degradation processes. VC, which is of the most concern has been shown to degrade naturally in almost any natural condition (i.e. Bradley and Chapelle, 1996, 1997).

### 2.2.1 Dual Well or Trench Recirculation Systems

Recirculation is desirable because it allows contaminated fluid to pass through an active treatment zone many times before exiting. During this recirculation, upgradient water is gradually added to the recirculation cell, while a portion of the water within the cell exits downgradient from the cell at the same rate. The rate at which water enters and leaves the treatment cell depends on the rate of recirculation, the gradient, hydraulic conductivity heterogeneity, and the angle of the system to the hydraulic gradient.

The Dover Air Force Base example illustrates such a recirculation system. This system involves the extraction of groundwater from a downgradient portion of the plume, addition of amendments, and the reinjection of that groundwater back into an upgradient portion of the plume (Fig. 2). This creates a recirculation cell and can result in effective mixing of the amendments within the plume. In most cases, multiple parallel recirculation cells are produced by placing a row of upgradient vertical injection wells, oriented perpendicular to flow direction, and a corresponding row of vertical withdrawal wells also oriented perpendicular to the hydraulic gradient (Fig. 2, 4a). However, injection or extraction can occur through horizontal wells (Fig. 4b) or trenches (Fig. 5). Groundwater recirculation rates as low as 0.25 gallons per minute have been used to maintain adequate mixing of amendments within the treatment zone (Lewis et al., 1998). In the Dover example, breakthrough of amendments was achieved within 30 days, suggesting that effective delivery was occurring.

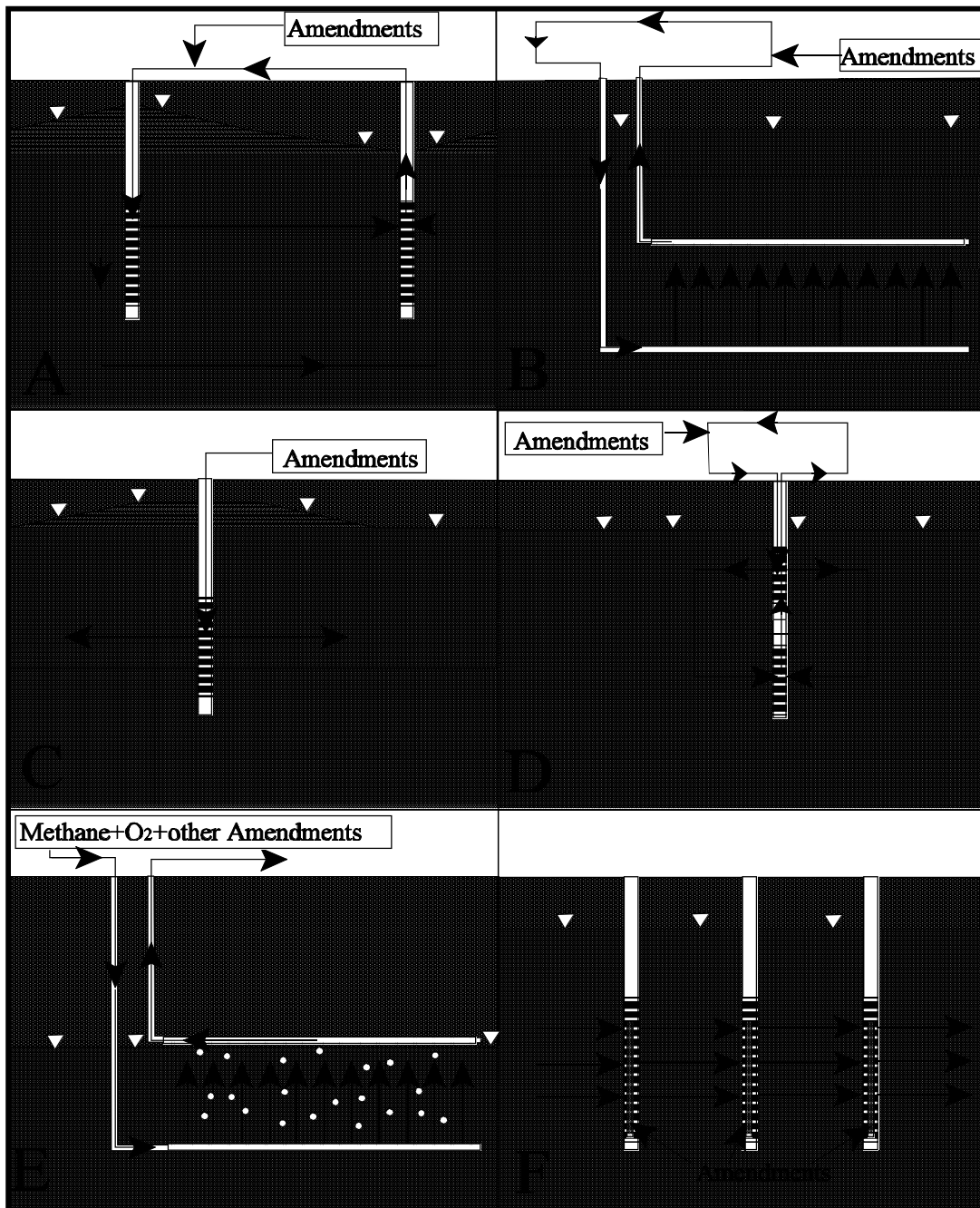

Figure 4. Various delivery systems used in enhanced in situ bioremediation systems. A) Dual Vertical Well Recirculation. B) Dual Horizontal Well Recirculation. C) Direct Injection. D) Vertical Well Recirculation. E) Horizontal Well Gas Injection. F) Passive Reactive Wells.



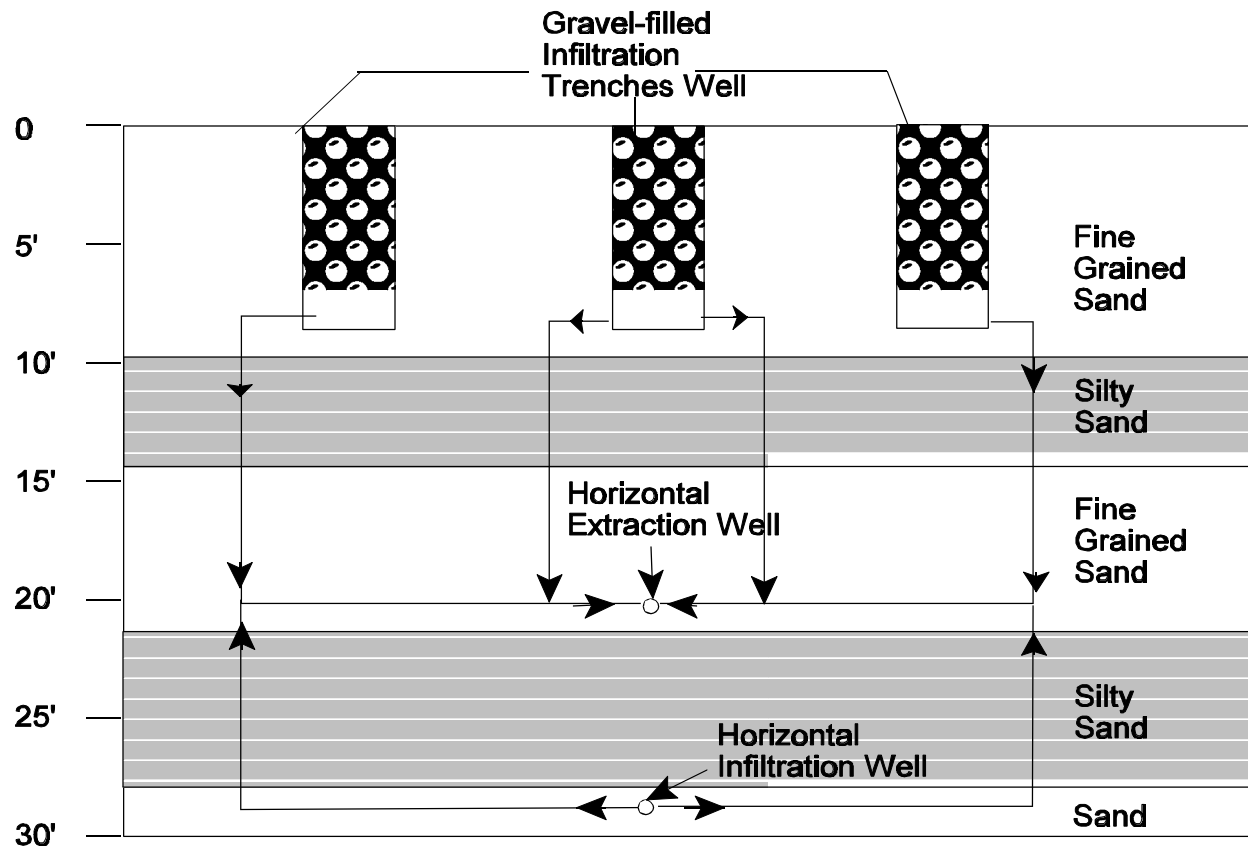

Figure 5. Diagram of the Pinellas, Florida in situ bioremediation delivery system. Horizontal extraction and injection wells are oriented perpendicular to cross section. (Modified from Weesner et al., 1998).

Litherland and Anderson (1997) used a series of extraction and injection trenches instead of vertical wells in a full scale *in situ* bioremediation system in the Gulf Coast of Texas. The trenches are spaced at 100 ft. to achieve the desired circulation rate. The system includes 1100 linear feet of injection trenches and 1800 linear feet of extraction trenches. A rate of 12 gallons per minute has been achieved. Breakthrough of amendments was achieved at all monitoring points, suggesting effective delivery.

Weesner et al. (1998) describe an active recirculation system at the Pinellas, Florida, DOE plant in which groundwater was extracted from a horizontal well and reinjected within a deeper horizontal well and a trench infiltration system near the surface (Fig. 5). The final pumping scheme maintained a pumping rate of 1.5 gpm from the extraction well, 0.9 gpm into the horizontal well and 0.6 gpm into the three trenches. The horizontal wells were used to maintain circulation through lower hydraulic conductivity zones, which were present at the site.

---

As discussed previously, the aerobic cometabolism system at Edwards Air Force Base represents a below-ground recirculation system that uses two vertical wells with extraction and injection ports to recirculate groundwater within two aquifers separated by an aquitard (McCarty et al., 1998; Fig. 3). Toluene was detected throughout the system, suggesting effective delivery.

Source area treatment or containment may be the primary goals of these recirculation systems, depending upon technical and regulatory goals. Active recirculation systems that are engineered as closed loops or nearly closed loops are ideal for treating high-concentration portions of plumes, including source areas. However, closed systems do not provide containment of upgradient contamination. If containment of a plume is the goal, then the system should be designed to allow some pass-through. One of the ways this can be accomplished is by orienting the recirculation cells at some angle to the natural hydraulic gradient. Another approach which provides plume containment is illustrated by the Edwards Air Force Base example (Fig. 3).

### 2.2.2 Injection Only Systems

A number of systems use gravity or forced injection of substrate and nutrients into one or more vertical wells (Fig. 4c). Nyer et al. (1998) describe results from the Lycoming Superfund Site in Williamsport Pennsylvania. TCE, DCE, and VC are the contaminants of concern, and all have shown reduction in concentrations. Recently, a full-scale system with 20 four inch diameter injection wells was completed in unconsolidated sandy silt overburden. A tank of molasses solution is maintained in a nearby treatment building. The molasses solution is added to the subsurface twice a day by pumping to the injection wells. The system is designed to treat chromium as well as the chlorinated ethenes. Preliminary results indicate reducing conditions in all of the monitoring points, suggesting effective amendment delivery. Honniball et al. (1998) describe a system in San Francisco in which yeast extract and disaccharide were injected into a vertical well. ORP has decreased in the most distant monitoring points, also suggesting adequate distribution.

These types of systems are useful for reducing contaminant levels in low-concentration plumes, or as a polishing step for other primary treatment technologies. They do not provide hydraulic containment, and may produce mounding of the piezometric surface which may cause the plume to expand somewhat in aerial extent.

### 2.2.3 Single Well Vertical Recirculation Systems

Europeans have for some time used amendment delivery systems in which groundwater is recirculated within vertically oriented recirculation cells through pumping and injection at different elevations within a single well. The contaminated groundwater enters the well at the bottom and leaves at the top or vice versa (Fig. 4d). The two screened intervals are isolated with a well plug of some sort. When an aquifer is contaminated by DNAPL, an upward operating vertical circulation well is used. These systems could be useful for small-scale treatment of source areas, or a series of them could be used to treat lower contamination portions of plumes. The aerobic cometabolic system at Edwards Air Force Base (Fig 3; McCarty et al., 1998) described previously, actually uses two recirculation wells and the presence of a naturally occurring aquitard to achieve larger scale recirculation than is possible with single well recirculation systems installed within homogenous aquifers.

#### 2.2.4 Gas Injection Systems

Methanotrophic treatment technology (MTT) systems require the injection of gases such as methane, oxygen, and triethylphosphate (TEP) (i.e. Legrand et al., 1998). For example, at the Former Naval Ammunition Depot in Hastings (NE), nutrients and air were injected at 250-300 SCFM, with methane injected at a 4% rate. This was done via a horizontal well, as is often the case for many sites (Fig. 4e).

#### 2.2.5 Passive Systems

Passive systems are those in which there is no forced injection or recirculation. Amendments are placed directly into the screened interval as solids or in cartridges and slowly dissolve into or disperse into the aquifer (Brown et al., 1997). One proposed system of passive delivery involves the construction of arrays of unpumped wells containing amendments in the path of the contaminant plume (Wilson and Mackay, 1997). The system can be designed to completely treat the plume or just reduce contaminant flux. Gilmore et al. (1998) describe a passive system in which bioamendments can be placed within filter packs in wells, referred to as bioreactive wells. Hydrogen Release Compound (HRC™), a patented organic compound, the goal of which is to release H<sub>2</sub> gas slowly for efficient respiration of halo-respiring organisms, can be placed within such well systems for *in situ* treatment (Koenigsberg et al., 1998; Harding Lawson Associates, 1998). Because there is no extraction system, these systems can save some engineering and operation costs and generally do not require permits. However, passive systems may require significantly larger numbers of injection wells in order to maintain adequate dispersion of the amendments than the recirculation systems.

### **2.3 Amendments**

#### 2.3.1 Substrate

Microbes require a substrate for growth and as an electron donor for energy. The ideal substrate will vary from site to site, but is a critical parameter for effective *in situ* bioremediation. In a few cases, sufficient organic substrate exists at the site to degrade existing chlorinated solvent compounds. However, in the vast majority of cases, some sort of substrate is added to the groundwater as an amendment.

For anaerobic reductive systems, a critical factor in the selection of a substrate is the rate at which the compound will release hydrogen. It has been shown that hydrogen is the actual electron donor in the dechlorination reaction. For example, Newell et al. (1998) proposes to directly inject hydrogen as an amendment at three Air Force installations. Presumably, where hydrogen is used as the electron donor, there is also sufficient substrate for microbial growth. If not, an additional substrate for growth would be added. However, some workers maintain that if hydrogen levels are too high, the dehalogenating organisms may be out-competed by more abundant microorganisms known as methanogens (i.e. Fennell et al., 1995; Becvar et al., 1997; Yang and McCarty, 1998). Substrates such as butyrate, lactate, and propionate are not direct methanogenic substrates. They

act only as indirect suppliers of H<sub>2</sub>, and do not spur population explosions and competition from methanogens (Becvar, 1998).

Another approach is to use a solid substrate amendment that will release hydrogen slowly over a long period of time. Recently, a patented substance called hydrogen release compound (HRC™) has been tested at some sites (Koenigsberg et al., 1998). It is a polylactate ester specially formulated for slow release of lactic acid upon hydration. The lactic acid in turn, releases hydrogen gas for dechlorination. HRC™ has been introduced as a slurry within a direct injection system and within a dual well recirculation system (Gohil, Personal Communication, 1998). These systems have only recently been tested and their overall performance has not been firmly established, however preliminary results suggest that the product stimulates dechlorination (Koenigsberg et al., 1998).

Other substrates that have been used for reductive systems include:

- Alcohols such as methanol, for reduction of a variety of compounds (i.e. Litherland et al., 1997).
- Food oils, such as corn oil, for CT reduction (Dybas et al., 1997).
- Vitamin B12 for CT and CF reduction (Lessage et al., 1996; Workman, D. et al., 1997).
- Sodium acetate for reduction of PCE to ethene (Chiu, Y. et al., 1997).

For cometabolic systems, a number of compounds, including methane, propane, ethylene, cresol, phenol, toluene, ammonia, isoprene, and isopropyl benzene have been observed to promote cometabolism in chlorinated solvents (AFCEE, 1998). Of these, phenol, methane, and toluene are the most widely used. Toluene has been shown to be effective for TCE oxidation by several studies (McCarty et al., 1998; Hopkins et al., 1993), and is recommended by the AFCEE guidance document (AFCEE, 1998).

Some of the common substrate amendments are included in Table 2. Methane, although most effective only for degradation of less chlorinated compounds (i.e. DCE, VC, etc.), has a cost advantage over other compounds and therefore may be useful for compounds such as TCE as well. Natural gas can be directly injected in MTT systems.

It should also be noted that some of these compounds are RCRA regulated substances (i.e. toluene, phenol) and/or have associated safety issues, such as explosive characteristics (i.e. hydrogen, oxygen, methane). Due to these safety issues, proper storage and/or utilization of these compounds should be administered.

---

---

### 2.3.2 Nutrients

Analyses of inorganic parameters in groundwater can provide an indication of the need for inorganic nutrient amendments. Commonly, nitrate, phosphate, and potassium are deemed to be insufficient to support the required microbial growth. Among the more common inorganic nutrients are ammonium sulfate, ammonium chloride, ammonium nitrate, disodium phosphate, monosodium phosphate, potassium monophosphate, polyphosphate salts, orthophosphoric salts, phosphoric acids, lawn and agricultural fertilizers (i.e. Cookson, 1995). Depending upon the amount of chlorinated solvent destruction and the type and amount of substrate, it may not be necessary to add nutrients.

In some cases, nutrients can become absorbed within the aquifer (Cookson, 1995). Phosphate can precipitate as calcium phosphate and occlude porosity. Adsorption of phosphate can cause clay swelling also producing porosity occlusion. The concentration of these nutrients should be monitored carefully to achieve a suitable concentration level. In addition, pH buffers, such as sodium hydroxide, have been used to buffer pH to acceptable ranges (i.e. Lewis et al., 1998).

### 2.3.3 Electron Acceptors

It is usually necessary to provide an electron acceptor for *in situ* systems involving aerobic cometabolism or direct oxidation. The most commonly used electron acceptor for aerobic cometabolism is oxygen (AFCEE, 1998). It is reasonably inexpensive and effective. Hydrogen peroxide can be effective as well, and while more expensive than oxygen, it may help reduce porosity occlusion by removing biological mass immediately adjacent to well screens. Oxygen Release Compound (ORC™) a commercial product has been used effectively to provide a slow steady release of oxygen to groundwater and soils in fuel contamination sites. In addition, it has been used with some success at sites to treat VC through direct oxidation (Lewis et al., 1997). It is not as suitable in cometabolic systems, because these systems usually try to achieve oxygen concentrations above 10 mg/L.

### 2.3.4 Bioaugmentation

A number of microorganisms have been used to promote cometabolism of chlorinated solvents. *Pseudomonas cepacia G4 phel* is one of the toluene-specific organisms that can degrade TCE (Shields et al., 1991). Another is *burkholderia cepacia* PRI 301e, a toluene oxidizing bacterium which produces a mobile strain called ENV435 (Stephan et al., 1998). The advantage of the more mobile strain is to allow more effective delivery within the contaminated zone without excessive occlusion of porosity. Pon and Semprini (1997) along with Bourquin et al. (1997) have evaluated the ENV435 strain at a chlorinated solvent site in Wichita, Kansas.

*Pseudomonas putida* and *mendocina* can oxidize TCE using toluene as the substrate (i.e. Mahaffey, 1992). Propane oxidizers include *Mycobacterium vaccae*, *Rhodococcus erythropolis*, *alcaligenes denitrificans* subsp. *xylooxidans* and *Xanthobacter stratin* (Ensign, 1992). *Methylosinus trichosporium OB3b* a known oxidative and cometabolic degrader of TCE and other chlorinated solvents, was injected into a plume at Chico, California (Duba et al., 1996). This was used in combination with a biofilter, that reduced concentrations of TCE in groundwater withdrawn from the well. Hansham and Freedman (1997) showed that use of *cyanocobalamin (Cbl)* speeds up

transformation of CT. Carbon tetrachloride degradation has also been aided with *Pseudomonas stutzeri strain KC* (Criddle et al., 1998; Dybas et al., 1997).

In most cases, such bioaugmentation results in the establishment of non-native bacterial populations that decrease within days or weeks due to competitive pressures or other environmental factors. As a result, bioaugmentation is an ongoing process and can be quite expensive. Engineered or genetically altered bacteria are generally of more concern to regulators than naturally occurring bacteria. EPA currently requires that genetically engineered microorganisms undergo a safety review under the Toxic Substance Control Act (TSCA) to evaluate any possible risk to human health or the environment before these micro-organisms are used in the field (USEPA 1991a). Reismann et al. (1998) suggest that genetically engineered microbes may represent a potential risk if they are very stable and achieve a high rate of gene transfer.

Bioaugmentation in anaerobic systems is less common, and few specific dechlorinating microorganisms have been isolated in natural systems. Engineered anaerobic dechlorinating microorganisms have also not been developed. *Dehalococcus ethegenes* strain 195, a halorespirer which is capable of complete dechlorination, was described by Maymo-Gattell et al. (1997). As previously discussed, the Dover AFB project successfully used a culture taken from the Pinellas, Florida site to fully dechlorinate TCE within the pilot demonstration there. Naturally occurring cultures such as the one used at Dover AFB, are generally of less concern to regulators than genetically altered bacteria.

#### **2.4 When Is Enhanced *In Situ* Bioremediation Appropriate?**

Within the past few years, there have been many new EISB pilots and some full-scale systems installed within the U.S. Many show promise in substantially reducing chlorinated solvent levels in groundwater plumes. The demonstration of PCE and TCE removal are particularly common, but certain studies have shown incomplete removal of DCE and VC.

Incomplete removal of DCE or VC does not necessarily indicate failure. For example, *cis* 1,2-DCE has a federal maximum concentration levels (MCL) of 70 µg/L as compared with 5 µg/L for TCE or PCE, so its accumulation represents a substantial decrease in risk for the site. Accumulation of VC, which has an MCL of 2 µg/L is of concern. However, VC has a number of potential degradation mechanisms, including biotic or abiotic oxidation in an aerobic environment, as well as direct degradation or reductive dechlorination in anaerobic environments (i.e. Bradley and Chapelle, 1996; 1997). As a result, accumulation of VC as an intermediate degradation product is not common. Therefore, EISB may be combined with some other polishing step or with natural attenuation to achieve site remediation goals.

There may be important technical or regulatory reasons why EISB should not be chosen as a potential remedy at a particular site. These include the presence of very low hydraulic conductivities or the presence of unusually high or low ORP that may prevent either reductive anaerobic, cometabolic, or oxidative biodegradation. Consideration of potential or actual human receptors could necessitate more active plume control or remediation. These issues are discussed in sections 3.0 and 4.0.

There have been many different types of EISB systems used. Not all have been successful. Many were not based on sound scientifically-validated degradation mechanisms. In particular, many vendors have used questionable bioaugmentation schemes to achieve *in situ* biodegradation with little success. Regulators faced with proposals for *in situ* bioremediation projects should critically examine the qualifications of the technical team proposing the technology. The proponents should be reputable firms with a proven track record in the bioremediation field. In most cases, they should be able to furnish background information concerning the past performance of the proposed system. Preferably, this background information should include articles in refereed journals or symposia proceedings. It may be useful to request site data from prior studies or references from regulators involved in prior studies.

### **3.0 REGULATORY AND POLICY ISSUES**

The ISB work group recognizes that EISB projects may involve the oversight of many regulatory authorities. In our studies we have defined several issues which may, and often do, impede the implementation of EISB systems. These include such issues as RCRA Active Management of Hazardous Waste and Land Ban issues, and Underground Injection Control (UIC) requirements. In order to further understand how each of these issues affect EISB projects, ISB interviewed representatives from five well documented sites. A point of contact, either a regulator or consultant, was contacted and asked to address a list of questions (Appendix D).

The 1996 and 1997 ITRC studies recognized the potential for regulators to resist selection of EISB technologies because the biological mechanisms are complex and poorly understood by many in the regulatory community. The studies also recognized that EISB technologies cross-cut many programs and agencies, each of which have their own requirements, policies, and approaches. As a result, regulators may face a very complicated path toward regulatory compliance when they allow for the deployment of an EISB technology.

#### **3.1 Regulatory Authority**

Remediation program regulatory authority can vary depending on the classification of a site (i.e. NPL listing, RCRA site, etc.) and the state in which a site is located. Oversight authority can differ from federal to state regulation. In addition, if a state is overseeing a site, there may be multiple agencies involved. This will largely depend upon the class of contaminant (i.e. hazardous or non-hazardous) and which media is involved (i.e. water, soil).

This fact became evident in the interviews conducted in 1997. All of the states included in the 1997 survey have active state-lead remedial programs that provide oversight for investigation and remediation of contaminated soil and groundwater (Appendix C). The level of oversight differs depending upon the type of program. All six states which responded currently have voluntary cleanup programs in which responsible parties enter into agreements with the states, and conduct site investigations and appropriate cleanups with minor state oversight. All six states also have active programs for conducting remedial investigations and cleanups, and possess enforcement authority at non-NPL sites. In addition, all states participate in the Department of Defense and State Memorandum of Agreement (DSMOA) in providing oversight for federal facilities investigation and cleanups. In general, EPA is the lead enforcement agency at most NPL and federal facility

---

sites, while states have varying degrees of oversight responsibility at non-NPL federal facilities or formerly-used defense sites.

All of the six states have basic RCRA permitting authority and have overseen remediation activities at permitted RCRA facilities. All six indicated that a state waste management or RCRA program may be involved in determining whether RCRA hazardous waste issues applied to projects, such as the EISB project. Of the six states, only Kansas and New Mexico do not currently have Corrective Action authority under RCRA, and thus would defer to the Regional EPA office for RCRA Corrective Action enforcement if that was deemed applicable.

### 3.2 RCRA Land Ban Issue

Current EPA policy does not consider groundwater and other environmental media to be solid waste in the sense of “being abandoned, recycled, or inherently waste-like”. Therefore a mixture of a hazardous waste and groundwater is not considered a hazardous waste under the mixture rule in Section 261.3 of CFR 40. However, groundwater contaminated with a listed waste “contains” a hazardous waste until the hazardous waste has been removed from the groundwater. EPA currently interprets its regulations to require that groundwater and other media which contain hazardous wastes (in this case, chlorinated solvent waste) must be managed as hazardous waste. This is known as the “contained-in” interpretation. This rule may apply to projects where ex-situ amendment and reinjection is conducted. If contaminated groundwater is determined to meet hazardous waste criteria under the “contained-in” rule, the project may face the following potential regulatory obstacles (see Section 3.4 for specific regulatory options):

- Contaminated media is to be treated as hazardous waste until it no longer contains the listed hazardous waste. If the groundwater does not contain a listed waste, contaminant concentrations above the Toxicity Characteristic (40 CFR 261.24-Table 1) levels will require treatment as a non-listed or non-characteristic hazardous waste.
- Withdrawal of contaminated groundwater (a contaminated media), may, in effect, constitute active management of hazardous waste, thus triggering land disposal restrictions (RCRA Section 3004 (f), (g), and (m)). Ex-situ amendment (addition of nutrients and substrates) will be considered as treatment of hazardous waste, thus a hazardous waste treatment permit may be required unless exempted under CERCLA (issuance of an approved Record of Decision) for example.
- Injection of hazardous waste into a usable aquifer constitutes land disposal (RCRA Section 3004 (f), (g), and (m) and 3020(a)), and may be prohibited in some circumstances (RCRA 3020(b)).

A letter from EPA official Shapiro (1995) supports the position that states and Regional EPA officials have flexibility in determining the appropriate “contained-in” concentrations for “de-listing” from being hazardous. Shapiro further indicated that the determinations could be made before or after treatment of the contaminated media, and that the determinations do not need to be made under a RCRA permit.

These land-ban issues may force changes in the design of EISB delivery systems which may unnecessarily increase their cost. However in a few cases, a favorable interpretation has been made



regarding EISB projects (See Appendix D, Cape Canaveral Site case study and Dover AFB case study).

### 3.2.1 The Land Ban Requirements

Under 40CFR 268, land disposal of hazardous waste is generally prohibited where treatment standards are not obtained. In addition, RCRA specifically stipulates that placement in an injection well constitutes land disposal. Therefore, if an EISB project is deemed to constitute active management of a hazardous waste, the ban against land disposal could apply. A number of waivers or exclusions may be possible. These include:

- The injection is allowed for CERCLA remediation under 121(d)(4) of CERCLA.
- The injection is allowed under RCRA 3020(b).
- A variance from treatment standards as discussed in 40CFR 268.44 can be obtained.
- For a CERCLA and RCRA sites, the injection may constitute movement within a defined area of contamination (AOC), and therefore will not trigger the land ban restrictions. A Corrective Action Management Unit (CAMU) designation will enable an exemption from the minimum technology requirements (MTRs), and LDR requirements.

RCRA attempted to address the reinjection issue by specifically allowing the reinjection of treated groundwater for the purposes of remediation in the case of RCRA or CERCLA cleanups (RCRA Section 3020(b)). However, this statute has been interpreted by some to require that there be substantial treatment resulting in a reduction in contaminant levels prior to reinjection. For an EISB system, it is often not economically feasible to clean up the contaminated groundwater prior to reinjection, and there are no sound scientific or risk-based justifications for doing so.

EPA maintains that treatability variances are warranted where the applicable numerical treatment standard for the waste cannot be achieved. Shapiro (1995) specifically states that treatability variances are applicable to contaminated media. Some of the state regulators in the 1997 document indicated that they would consider a treatability variance for an EISB project.

RCRA 3004(k) does not consider movement of contaminated media within a defined area of contamination (AOC) as land disposal (40 CFR 300). For a CERCLA and RCRA site, the injection may constitute movement within a defined area of contamination (AOC) and will not trigger land ban restrictions. The movement within AOC “exemption” could apply to virtually any site, whether being remediated under CERCLA, RCRA, or other programs (see Appendix D, Cape Canaveral case study). A Corrective Action Management Unit (CAMU, 40 CFR 264, Subpart S) designation will enable an exemption from MTR and LDR requirements (See Table 5 for the LDR and permit requirements for various delivery methods of the nutrients and/or substances).

---

**Table 5.** Potential Federal Regulatory Permits and LDR requirements for the Enhanced In-Situ Bioremediation of hazardous groundwater.

Delivery Method	LDR Compliance Requirements	Hazardous Waste Treatment Permit			Class V UIC Permit	
		CERCLA Site	RCRA Site	Non-CERCLA or RCRA	RCRA or CERCLA Site	Non-CERCLA or RCRA
Passive or Reactive Well	No	No, if the ROD is approved	Permit Modification or CAO	Yes, Unless Waived	Usually Not Required	Usually Not Required
Injection Only System	No	No, if the ROD is approved	Permit Modification or CAO	Yes, Unless Waived	Substantial Compliance Usually Required	Permit Usually Required
Single Well Recirculation System	No	No, if the ROD is approved	Permit Modification or CAO	Yes, Unless Waived	Substantial Compliance May be Required	Permit May be Required
Dual Well or Trench Recirculation System	Potentially, No - if AOC or CAMU designation (See Sect. 3.0)	No, if the ROD is approved	Permit Modification or CAO	Yes, Unless Waived	Substantial Compliance Usually Required	Permit Usually Required **
Gas Injection System	No	No, if the ROD is approved*	Permit modification or CAO*	Yes, Unless Waived*	Substantial Compliance May be Required	Permit May be Required

\* - An air permit may be required, depending on the extent/amount of expected air emissions.

\*\* - If proposed reinjection is determined to be a Class IV injection, it could be prohibited for Non-CERCLA or RCRA sites.

AOC - Area of Contamination

ROD - Record of Decision

CAMU - Corrective Action Management Unit

UIC - Underground Injection Control

CAO - Corrective Action Order

CERCLA - Comprehensive Environmental Response Compensation and Liability Act

LDR- Land Disposal Restrictions

RCRA - Resource Conservation and Recovery Act

### 3.3 Underground Injection Control (UIC) Requirements

Currently, authority for regulating injection wells is split between states and the federal government under the Underground Injection Control (UIC) program. A summary of various states which possess UIC primacy or partial primacy are included in Appendix G.

---

Under the UIC program, injection of any fluid into a well is prohibited, except as authorized by a permit or rule. If the injected fluid is a non-hazardous “waste”, the injection wells used for remediation are generally designated as Class V wells under the UIC program. For example, the use of toluene and/or phenol as a product is not prohibited by Federal and/or State regulations due the fact that they are being administered as a “product” and not as a “waste”.

If Class V wells are covered by the Federal UIC program, no permit is required, as they are authorized by rule. All of the states surveyed in 1996-97 (OR, KS, CA, TX, NJ, NM) indicated that injection well permits, or substantial compliance with Class V permit requirements would have to be obtained for an EISB project involving injection for remediation purposes. Additional states were surveyed in 1998, much of this data concurred with the findings from the 1996-97 survey (Appendix G).

When extracted groundwater is to be treated as a hazardous waste under the “contained-in” rule, reinjection of the groundwater could be considered a Class IV well injection. 40 CFR 144.13 specifically prohibits construction of Class IV wells, with some exceptions. One of these exceptions is injections of treated groundwater for CERCLA and RCRA cleanups. 40 CFR 144.13 (c) states: *“Wells used to inject contaminated ground water that has been treated and is being reinjected into the same formation from which it was drawn are not prohibited by this section if such injection is approved by EPA pursuant to provisions for cleanup of releases under the Comprehensive Environmental Response, Compensation, and Liability Act of 1980 (CERCLA), 42 U.S.C. 9601-9657, or pursuant to requirements and provisions under the Resource Conservation and Recovery Act (RCRA), 42 U.S.C. 6901 through 6987.”*

Other exceptions from the Class IV prohibition include:

- Injections into aquifers which underlie the lowermost formation containing a drinking water supply (40 CFR 144.13 (d) (1)).
- Wells used to inject hazardous waste into aquifers where no underground source of drinking water exists within one quarter of a mile for the injection (40 CFR 144.13 (d)(2)).

In both instances, the injection wells would have to comply with Class I UIC regulations. The effective prohibition of most underground reinjection of contaminated groundwater at non-CERCLA or non-RCRA sites represents a significant regulatory obstacle. This obstacle may force the use of an alternative means such as horizontal drilling and trickle or injection nests below surface to distribute the amendment which may be less effective than true vertical injection (see Appendix D, Cape Canaveral Site Study).

Certain technical requirements would likely be imposed as part of the injection well permit. These include the establishment of a “containment area” of extraction and/or monitoring wells near the site perimeter to monitor the effectiveness of the treatment technique. At least two states (KS, OR) indicated in the 1997 ITRC survey that they would require some demonstrated evidence of containment through approved hydrologic modeling (see Appendix C). It is likely that the materials added to the batch injection would have to be analyzed by a state-approved laboratory prior to mixing. Finally, it is likely that regular monitoring and reporting of results to the UIC permitting

---

authority would be required. An example of a permit application for a Class V injection project from Kansas is included in Appendix F.

### 3.4 Future Considerations for Regulatory Agencies to Address Regulatory Barriers

The ITRC has identified the following potential regulatory issues that may prevent deployment of the accelerated anaerobic bioremediation of chlorinated solvents in groundwater. Potential regulatory options/solutions are also presented below. Currently, the ITRC is in the process of seeking U.S. EPA's clarification on these issues (refer to Appendix E).

1. Reinjection under RCRA 3020(b): RCRA 3020(b) states "...contaminated groundwater must be treated to substantially reduce hazardous constituents prior to reinjection". It is unclear that this requires both treatment and a reduction of contaminant levels prior to injection, or just substantial treatment prior to injection, with the ultimate result being a reduction in contaminant levels within the aquifer. Dover Air Force Base project is an example that acquired EPA's approval for *ex situ* amendment and subsequent reinjection. Another project at an Air Force facility in Florida (refer to Appendix D, Cape Canaveral case study) has been approved by the EPA Regional Office. At this site, the amended groundwater will be re-introduced to the subsurface via an infiltration gallery rather than an injection well. Although an injection well is a more effective method, an injection prohibition by the state caused a process modification. The projects involving an *in situ* amendment only, or an *ex situ* amendment of non-hazardous groundwater (concentrations of hazardous compounds below the TC levels, for example) will not be subject to the restrictions on hazardous groundwater injection.

2. Area of Contamination (AOC) or Corrective Action Management Unit (CAMU): For a CERCLA or RCRA site, the AOC (40 CFR part 300) and the CAMU (40 CFR part 264 Subpart S) designation will facilitate a rapid and cost effective site remediation by reduced regulatory requirements as long as the waste is managed (treated, stored or disposed) within the AOC or CAMU. If managed within the AOC or CAMU, the LDR treatment standards and minimum technology requirements (MTRs) will not be triggered. It may be possible to stipulate that an AOC can be defined by the aerial extent of the plume, or that an *ex situ* extraction and reinjection unit can be designated as a CAMU at RCRA sites.

3. Treatability variance: When an AOC or CAMU approach cannot be used for any reason, it may be appropriate to use a Treatability Variance (40 CFR 268.44) to establish ultimate cleanup levels. A Treatability Variance may be obtained to allow extracted groundwater to be reinjected into the subsurface (at higher concentrations than the LDR treatment standards) to enhance *in situ* biotreatment technologies. It may be possible that Treatability Variances can be issued to promote the use of amended groundwater injected into the aquifer to accelerate *in situ* bioremediation.

4. Class IV UIC wells: When extracted groundwater is to be treated as hazardous waste under the "contained-in" rule, reinjection of the contaminated groundwater into an aquifer to enhance bioremediation may be considered a Class IV injection. This injection would be prohibited for most non-CERCLA or non-RCRA sites (40 CFR 144.13). This determination may, in some cases, require unnecessary treatment of amended groundwater prior to reinjection, and may result in unacceptable costs for EISB projects. ITRC is currently seeking EPA's clarification that wells being used for

reinjection of amended contaminated groundwater for the purpose of remediation at all sites (including non-CERCLA and non-RCRA sites) will be allowed as Class V injections.

#### **4.0 TECHNICAL REQUIREMENTS FOR IMPLEMENTATION OF ENHANCED *IN SITU* BIOREMEDIATION**

The Draft Technical Protocol by Morse et al.(1998) proposes four phases for implementation of EISB pilots for reductive anaerobic biological *in situ* treatment technology (RABITT). These include:

- site assessment
- treatability test preparation
- microcosm study
- field testing

The Dupont bioremediation technology team recommends a precursor assessment in which the site is evaluated for indigenous biological activity (Fig. 6). A second phase laboratory optimization study is conducted to determine the optimal conditions for anaerobic reductive dechlorination to occur. A tracer test and hydrogeological modeling is done to obtain detailed information on aquifer parameters and in particular, aquifer heterogeneities. A field pilot is then implemented that involves either a single-borehole bioreactor test, or a multiple-piezometer well test in which amendments are delivered to the groundwater through a vertical well recirculation system. After the field pilot has been evaluated and deemed successful, a full scale system may be designed with consideration to an engineering evaluation of the field test data (Beeman et al., 1998).

The most important elements of each of these phases of activity are described in the following sections. For more detailed discussions of requirements for implementation of anaerobic EISB systems, the reader is referred to Morse et al. (1998). For implementation of cometabolic studies, the reader is referred to the Air Force Center for Environmental Excellence (1998) and Jenal-Wanner and McCarty (1997).

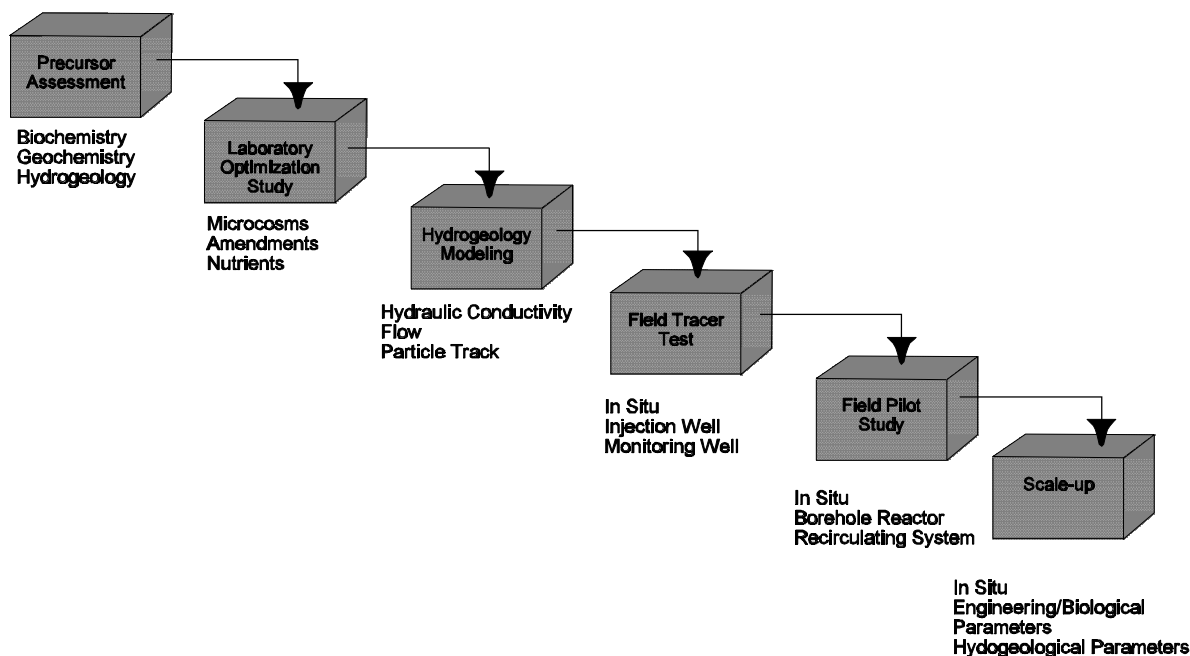

Figure 6. Steps for implementation of enhanced in situ bioremediation systems by the Dupont Bioremediation Team (from Beeman et al., 1998).

#### 4.1 Site Assessment Phase

The purpose of the site assessment phase is to determine whether or not a particular site may be suited for implementation of an EISB pilot. The goals of the pilot should be clearly delineated prior to any site characterization. They should include the targeted cleanup levels, time constraints, and cost. Most EISB pilot studies will be initiated after significant prior site characterization has been completed. As such, much necessary data for evaluating the potential of EISB and designing the system will be available. This data should be reviewed and evaluated when first considering implementation of the technology. It is possible that this information alone will be sufficient to determine whether to implement a pilot study. However, in almost all cases, some additional site characterization will be necessary to locate the pilot and to decide upon the appropriate type of delivery, degradation, and amendments.

The major elements of an EISB site characterization include: review of existing site data, development of work plans, hydrogeologic and geochemical characterization, source area characterization, and plume characterization. After adequate site information has been obtained, a good site conceptual model should be developed by incorporating these data. Based on this compiled data, a decision to go forward with the EISB pilot can be made. The following briefly discusses each of these steps. For a more detailed discussion, see Morse et al. (1998) or the

---

American Society for Testing and Materials (ASTM) Method D5730, Standard Guide for Site Characterization for Environmental Purposes with Emphasis on Soil, Rock, the Vadose Zone and Groundwater.

#### 4.1.1 Review of Previous Site Data

For those who are considering EISB at a particular site, we recommend first reviewing general site conditions to determine which type of EISB deserves the most initial consideration and evaluation. This will help focus the site assessment and later phases of the investigation. For example, sites where the contaminated aquifer contains abundant naturally occurring organic carbon should probably not be considered for a cometabolic or oxidation *in situ* pilot. Sites with very high ORP and flow rates may not be susceptible to anaerobic biodegradation.

Before conducting a site characterization, a number of information sources should be compiled and reviewed. A site history and background should be assembled that includes information about previous manufacturing and chemical use at the site. The distribution of major contaminants in the plume, soils, and any known sources of dense non-aqueous phase liquid (DNAPL) should be shown on maps. If there are multiple-level wells with concentration data, plots of contaminant concentrations along a cross section should be developed. All of the known source areas should be identified. Inorganic geochemical data and various field parameters, such as pH, temperature, conductivity, and oxidation-reduction potential (ORP) should be plotted or contoured on maps at the same scale as major contaminant data. A list of such parameters normally included in a natural attenuation study are given in Table 6. Piezometric surface maps at the same scale as contaminant maps should be prepared as part of the site assessment. Hydraulic gradients in areas of interest can be estimated using graphical methods. Significant variations in the piezometric surface over different monitoring events should be noted, as these may affect the performance of the pilot system.

It should be noted that these elements are not required. However, the collection and review of this data will provide further insight into the related technical and regulatory parameters, as well as contribute to an increased understanding of the site characterization.

#### 4.1.2 Development of Site Characterization Work Plans

Appropriate work plans for any site characterization should be assembled and approval obtained from appropriate federal and/or state regulators. These work plans may be separate and more limited in scope than later work plans for implementation of the pilot test. It may be possible to present the site characterization work plans as brief addenda to prior site or remedial investigation plans. The addenda may only delineate any deviations from the existing sampling analysis, quality assurance and quality control, and health and safety plans. These work plans should follow EPA guidance such as the *EPA Guide for Conducting Treatability Studies Under CERCLA (EPA / 540/2-89-059; 1989)* or *Guidance for Conducting Remedial Investigations and Feasibility Studies under CERCLA (EPA 540/6-89/004)*. The health and safety plan should be developed in accordance with

Table 6. Description of Analytical Parameters Used to Assess Intrinsic Bioremediation. From Remedial Technologies Development Forum (1998) and Wiedemeier et al. (1996) . These parameters should be used included in site characterization and evaluation of pilot tests for enhanced in situ bioremediation.

Parameter	Description
Alkalinity	Provides an indication of the buffering capacity of the water and the amount of carbon dioxide dissolved in the water.
pH	Microbial activity tends to be reduced outside of a pH range of 5 to 9, and many anaerobic bacteria are particularly sensitive to pH extremes.
Temperature	Affects rates of microbial metabolism. Slower biodegradation occurs at lower temperatures.
Dissolved oxygen	Highest energy-yielding electron acceptor for biodegradation of organic constituents, <10 ppm.
Redox Potential	A measure of the oxidation-reduction potential of the environment. Ranges from +500 mV for aerobic conditions to -300 mV for methanogenic conditions.
Sulfate	Used as an electron acceptor in biodegradation of organic constituents. Reduced to form sulfide. High sulfate concentrations may prevent methanogenic conditions from developing.
Sulfide	Microbially reduced form of sulfate. Indicates reduced conditions.
Methane	Indicator of anaerobic conditions and of methanogenic bacteria. Produced by the microbial reduction carbon dioxide. Solubility limit 25 to 40 ppm.
Ethane/ethene	Metabolic end product of reductive dehalogenation of halogenated ethenes and ethanes
Total organic carbon (TOC)	A measure of the total concentration of organic material in water that may be available for biological degradation.
Chloride	May be useful as an indication of biological dechlorination and as a conservative tracer.
VOC/daughter products	Provides a measure of the type and quantity of parent and biogenic daughter products.
Iron (total, dissolved)	A product of bacterial iron reduction. Only the reduced form (ferrous) is soluble. The oxidized form (ferric) is used as an electron acceptor.
Nitrogen	An essential nutrient of microbial growth and biodegradation.
Nitrate	Used as an electron acceptor. Consumed next after oxygen.
Nitrite	Product of nitrate reduction. Produced only under anaerobic conditions. Rarely observed.



---

the Occupational Safety and Health Administration (OSHA) regulations 20 CFR 1910.120, *The Hazardous Waste Operations and Emergency Response Rule*.

#### 4.1.3 Hydrogeologic and Geochemical Characterization

The implementation of an EISB system should be based on a sound understanding of the geology and hydrogeology of the site. Even at sites which have had multiple phases of site characterization, there will likely be a need for additional characterization of the geology and hydrogeology. This information is crucial for the accurate delivery of amendments throughout the contaminated aquifer. The existence of small-scale stratigraphic units with anomalously high or low hydraulic conductivity can cause significant uncertainty in predicting flow within the affected aquifer and can make it difficult for uniform delivery of amendments.

Low hydraulic conductivities in the contaminated aquifer may prevent acceptable delivery rates to the affected portion of the plumes. In general,  $10^{-4}$  cm/s is considered a minimum average hydraulic conductivity necessary to implement EISB (Morse et al., 1998). However, sites with lower hydraulic conductivities have had some successful pilot demonstrations (i.e. Honniball et al., 1998; Litherland and Anderson, 1997). Sites with very high hydraulic conductivity ( $>10^{-1}$  cm/s) may require high pumping and injection rates in order to maintain a suitable hydraulic containment and reach the targeted portion of a plume, making *in situ* bioremediation a very expensive proposition.

All previous subsurface geologic data from the site needs to be assembled, including well logs, drill core logs, geophysical logs, geotechnical tests, and measured sections of surface exposures. This information should be reviewed with a perspective of the regional geological setting, which should be researched from geological surveys of the area. If this information is not sufficient to demonstrate likely lateral or vertical heterogeneities of hydrogeologic parameters of concern (i.e. hydraulic conductivity, storativity or storage coefficient, and porosity), then additional subsurface information should be obtained.

Morse et al. (1998) recommend that cores should be obtained on at least 20% of all wells. These should be collected according to ASTM Standard Guide D2113-83 (Table 7). For unconsolidated material, split spoon samples should be obtained from all borings and wells using ASTM Standard Guide D1586-84 (Table 7).

Cores and soil samples should be described in enough detail to delineate lateral and vertical changes in hydraulic conductivity or porosity of one order of magnitude or more. In order to design an efficient delivery system for an EISB system, it will be necessary to anticipate the likely presence of anomalous hydrogeologic units smaller than the scale of the pilot cell dimensions (usually about 50 feet by 50 feet). If the previous site investigation is sufficient to demonstrate that there are no abundant small-scale sedimentary facies such as fluvial or tidal channels, bars, etc., and that lithologies are generally correlatable across the site, an additional subsurface geological study may not be necessary until installation of the pilot system. Additional data will be obtained from direct push sample points or from monitoring, injection, and extraction wells at the selected site. Detailed

Table 7. Guidance Documents for Site Assessment and Pilot Installation.

Activity	Guidance Documents
Site Characterization - General	ASTM D5730-96
Preliminary Assessments Under CERCLA	EPA OSWER Directive 9345.0-01A, 1991
Site Inspections Under CERCLA	EPA OSWER Directive 9345.1-05
Remedial Investigations/Feasibility Studies	EPA OSWER Directive 9355.3-01
Site Characterization - Cold Regions	ASTM D5995-96
Site Characterization - Expedited or Accelerated	ASTM PS 85-96
Developing Conceptual Model for a Site	ASTM E1689-95
Groundwater Sample Selection, Determining Minimum Number of Required Sample Points	ASTM D5474-93 ASTM D5408-93 ASTM D5409-93 ASTM D5410-93
Groundwater Sampling	EPA/540/P-91/007; 1991 EPA/600/2-85/104; 1985
Describing Geologic Cores	ASTM D5434-93 ASTM D5878-95
Soil Classification for Soils and Cores	ASTM D2487-93 ASTM D2488-93
Air Rotary Drilling	ASTM D5782-95
Dual-Wall Reverse Circulation Drilling	ASTM D5781-95
Water Rotary Drilling	ASTM D5783-95
Hollow Stem Auger Drilling	ASTM D5784-95
Diamond Tipped Coring	ASTM D5541-94
Installation of Monitoring Wells	ASTM D5092-90,95
Installation of wells in granular aquifers	ASTM D5521-94
Casing Advancement Drilling Methods	ASTM D5872-96
Water Level Measurements	ASTM D4750-87,93

Table 7 (Continued)	
Groundwater Sampling	ASTM D4448-85a,92
Direct Push Sampling of Groundwater	ASTM D6000-96
Measuring Hydrogeologic Parameters	ASTM D5126-90 ASTM D4943-91 ASTM D6000-96
Test Kit Analyses for Inorganics	ASTM D5463-93
Soil - Total Organic Carbon	SW846 Method 9060
Soil - Total Iron	SW846 Method 7380
Laboratory Treatability Sampling	ASTM E1287-97
Determining Data Quality Objectives	EPA Oswer 9355.0-07B
Groundwater Modeling	EPA SW868 D5447
Groundwater Model-Boundary	ASTM D5609
Groundwater Model - Initial Conditions	ASTM D5610
Groundwater Model - Sensitivity Analysis	ASTM D5611
Groundwater - Dissolved Organic Carbon	EPA Method 415.1
Groundwater, Soil - VOCs	EPA SW846 Method 8260B
Groundwater - NH <sub>3</sub>	EPA SW846 Method 350.2
Groundwater - NO <sub>3</sub> , NO <sub>2</sub> , SO <sub>4</sub>	EPA Method 300
Groundwater - Cl, Br	EPA Method 300
Groundwater - Conductivity	EPA Method 120.1
Groundwater - Alkalinity	EPA Method 310.1
Groundwater - pH	EPA Method 150.1
Groundwater - Iron	EPA Method 3500-Fe

---

architecture of lithostratigraphic units can be put into hydrogeologic models for the site to show where there may be ineffective delivery of amendments.

Most geologic studies at environmental sites do an inadequate job of characterizing the mineralogical or compositional spatial variation of aquifers. In particular, there are specific mineralogical and compositional features which may significantly affect biodegradation. These include the distribution of iron and manganese oxides or oxyhydroxides, iron or other base metal sulfides, carbonates, and sulfates. Iron and manganese oxides or oxyhydroxides may function as electron acceptors during biodegradation of chlorinated solvents. In particular, recent studies have shown that direct biodegradation of VC as an electron donor may occur preferentially where  $\text{Fe}^{3+}$  exists as an abundant electron acceptor (Bradley and Chapelle, 1996). Also, an abundance of iron or manganese oxides may act to buffer redox potential through the activities of iron-reducing bacteria. If these reactions are of potential importance to the proposed pilot, then it may become necessary to determine the abundance of iron or manganese oxides through a quantitative or semiquantitative method. ICP

analysis of metals in the sediment will give total iron concentration, and this may be directly related to iron oxide or oxyhydroxide abundance. However, total iron concentrations will not necessarily provide an indication of the abundance of available  $\text{Fe}^{3+}$ . An examination of thin sections from cores may be a useful, quick way to estimate the abundance of iron oxyhydroxides, the most abundant readily available source of  $\text{Fe}^{3+}$ . The demonstration of iron and manganese oxide abundance can be used during the pilot to explain unexpected high rates of VC degradation in the absence of strongly reducing conditions, or the corresponding appearance of ethene.

The abundance of organic carbon observed in cores should be compared with measured total organic carbon (TOC) of different facies. This will affect aquifer ORP. An abundance of sulfate minerals, such as gypsum or anhydrite, may also affect oxidation-reduction potential (ORP) to sulfate-reducing levels through respiration of sulfate-reducing bacteria. The presence of abundant carbonate minerals produces high alkalinity groundwater which tends to buffer pH to values greater than 7.5, especially when the partial pressure of  $\text{CO}_2$  is at normal levels. On the other hand, very clean quartz sandstone may lack pH buffering capacity resulting in a groundwater pH which may decrease significantly below 7.0 during biodegradation. In some cases, these minerals can be identified during field examination of soil samples or cores. However, thin section examination of core samples may be useful in determining the approximate abundance of these minerals. The documentation of high sulfate mineral abundance can be used during the pilot demonstration to explain slow rates of reductive dechlorination of cDCE and VC.

Most sites with prior investigations will have some existing hydrogeologic information, including piezometric surface contour maps, estimates of hydraulic gradient, hydraulic conductivity, porosities, and compilations of regional hydrogeologic information. In most cases, the hydraulic conductivity estimates will be based on slug tests or aquifer pumping tests. Pumping tests give useful information on the large-scale hydrogeologic properties, and may be useful for an initial evaluation of the potential for EISB systems. Slug tests give more specific information about discrete lateral and vertical portions of the plume. However, hydraulic conductivities estimated from slug tests should be viewed with caution. In particular, slug tests may underestimate hydraulic conductivities because of particulate clogging of well screen and packing. Tests for determining hydraulic properties should be selected according to ASTM Standard Guide D4043-91. Slug tests

---

should be conducted according to ASTM D4044 and D41014. Pumping tests should use be evaluated using ASTM Standards D4105 and D4106 (Table 7).

Recently, sensitive borehole flowmeters have become commercially available, allowing multiple level velocity measurements within a single well (Molz et al., 1994). These provide measurement of flow rates under ambient and constant pumping rates. Although there will be significant error in calculation of hydraulic conductivity versus depth, the procedure will at least delineate relative changes in hydraulic conductivity and thus give valuable information concerning aquifer heterogeneities.

Effective porosity can be determined using a method in Fetter (1994). It is described in detail in the ESTCP Protocol by Morse et al. (1998). Water levels should be measured over the entire site using an electronic water-level indicator. A piezometric surface map should be developed and compared with prior piezometric maps.

#### 4.1.4 Source Area Characterization

In many cases, EISB groundwater systems will be designed to address hot-spots of groundwater contamination within or near source areas, rather than low concentration areas in more distal portions of a plume. *In situ* bioremediation within a mass of dense non-aqueous phase liquids (DNAPL) is not feasible, because microorganisms require contact with water. However, biodegradation has been demonstrated to occur at very high concentrations of chlorinated solvents comparable to concentrations surrounding DNAPL sources (i.e. Nielson et al., 1998). As a result, the technology offers a promise as source area remediation technology. A number of tools are currently available for source area characterization. These include:

- soil gas or passive soil gas surveys
- direct- push technology sampling and on site/off site analysis of soils, water, and non- aqueous phases
- partitioning interwell tracer test (PITT) for determining the presence and volume of DNAPL
- surface and subsurface soil sampling.

Identifying the location of DNAPL is often a very difficult process; however, it may be necessary to at least determine the likely presence of DNAPL and its approximate location. This is especially true if the goal of the proposed EISB system is to reduce contaminant mass in the source area. A site can be suspected of containing DNAPL if dissolved chlorinated solvent concentrations in groundwater exceed 1% of the solubility of the compound (Pankow and Cherry, 1996).

The University of Texas at Austin (UT) and Intera, Inc. have jointly developed an *in situ* technology for measuring the volume and percent saturation of NAPL contamination trapped in vadose zone sediments. The technology is essentially a large-scale application of chromatography. The migration of a partitioning tracer between an injection well and an extraction well is retarded relative to a non-partitioning tracer because it spends a fraction of its residence time in the immobile residual NAPL (Jin et al., 1995).

---

Recently, new techniques for passive soil gas surveys have allowed the detection of subsurface volatile organic compounds at very low levels. The techniques can not only characterize concentrations in soils or DNAPL areas, but can also be used to help delineate the plume and establish monitoring well locations. Two commercially available passive treatment systems are GORE Sorber™ and Emflux™.

Measurements of VOC concentrations in soils are difficult to achieve. Even with the assistance of laboratory analysis, the true representation of the contaminants mass in the soil may not be accurately reflected. The new EPA VOC soil collection method 5035, which uses methanol as a sample preservative, should be used along with appropriate SW846 analytical methods.

An alternative to conventional soil borings are direct-push sampling methods. These should be used when there are significant depths of unconsolidated soil. They are generally capable of reaching sampling depths of about 60 feet. ASTM Standard D6001 (Table 7) should be used for direct push sampling.

#### 4.1.5 Plume Characterization

Prior to pilot installation, the target plume should be characterized. The following information should be determined:

- the downgradient and upgradient extent of dissolved phase chlorinated solvents in groundwater
- the variation in lateral and vertical concentrations of major chlorinated solvents in groundwater as well as degradation products of these compounds
- the variation in lateral and vertical concentration of physical and chemical parameters which are indicative of or may inhibit biodegradation processes (Table 6)
- at least two rounds of monitoring data spanning at least one year

The data should be contoured and there should be sufficient spatial distribution of sample points so that an accurate estimate of contaminant concentrations along the axis of the plume can be determined. It is not as critical to have abundant data control away from the plume axis, assuming the plume is symmetrical in origin. However, if the plume distribution is altered by hydrogeologic obstructions, additional monitoring points may be needed.

Samples should be collected using reliable methods as discussed in the *Compendium of ERT Groundwater Sampling Procedures* (EPA/540/P-91/007;1991) or the *Practical Guide for Groundwater Sampling* (EPA/600/2-85/104;1985; Table 7). In particular, proper preservation techniques should be used, and analyses should be conducted within specified storage times. Analyses of chlorinated solvents should follow an approved EPA technique, such as EPA method 8260B (Table 7).

A number of parameters have been proposed to evaluate the potential for natural attenuation of chlorinated solvents (Table 6). These parameters are critical for understanding biodegradation reactions that might occur at the site and should be measured site wide.

---

Water well installation should follow ASTM guides D5783-95, D5784-94, D5875-95, D5872-95, and D5782-95 (Table 7). Individual states may also have specific requirements concerning well construction, and most have well registration/permitting requirements. Direct push sampling of groundwater may be appropriate for more detailed plume delineation. However, there will still need to be a number of permanent monitoring wells for evaluation of the pilot data.

#### 4.1.6 Conceptual Model and Site Evaluation

Previous and new site information should be evaluated. Three-dimensional conceptual site models with concentrations of all important parameters should be assembled. The data should be evaluated for the likely success of EISB. The ESTCP Protocol (Morse et al., 1998) includes a numerical rating system for reductive anaerobic bioremediation projects. This system may eliminate some sites which may not be conducive to anaerobic bioremediation alone, but which might be amenable to combinations of anaerobic and other systems, such as oxidation. For that reason, it should be used with caution. Also, it is important to note that the rating system should not be applied to sites for EISB using cometabolic or oxidation degradation mechanisms. These types of degradation systems, in some cases, have opposing requirements for site condition - particularly for oxidation-reduction potential (ORP).

For cometabolic sites, the lines of evidence for determining the suitability of a site differs significantly from sites being evaluated for anaerobic biodegradation. The AFCEE guidance document on cometabolic systems (Air Force Center for Environmental Excellence, 1998) recommends only sites with low organic content be selected in order to reduce the capacity of the aquifer to buffer ORP to low values (Fig. 7). Hydraulic conductivities should be high. Importantly, contaminants that do not degrade cometabolically, such as PCE, CT, or 1,1,1-TCA should not be present. 1,1-DCE may degrade cometabolically, but even at low concentrations (>16 µg/L) it may inhibit degradation of other chlorinated solvents through a toxic effect (Dolan and McCarty, 1995).

A more involved site screening process is recommended by the AFCEE guidance manual, and is contained within software developed by the Air Force Institute of Technology (AFIT), Wright-Patterson AFB, Dayton Ohio. The manual for this software is included in the AFCEE guidance document (Air Force Center for Environmental Excellence, 1998), and both were downloadable at the time of this publication from the World Wide Web at <http://en.afit.af.mil/env/insitubio.htm>.

In order to use this software, the following parameters must be known:

- contaminants present
- contaminants present at the highest concentration
- whether the site is isotropic or anisotropic or if a confining layer is present
- aquifer saturated thickness
- regional hydraulic gradient
- influent concentration of the contaminant (i.e. contaminant concentration in the upgradient portion of the proposed system)
- desired effluent concentration of the contaminant (i.e. the regulatory cleanup level)
- depth of the water table

- hydraulic conductivity (or at least the geological composition of the aquifer).

The program not only calculates the likely efficiency of aerobic cometabolism, but also calculates likely costs associated with the project.

## **4.2 Laboratory Treatability Test Phase**

In most cases, if adequate site characterization data is gathered and the data reveal that natural attenuation is occurring, proceeding with EISB is supported. However, at most sites field data alone will not be sufficient to establish the suitability for a field pilot demonstration regarding EISB. The ESTCP and AFCEE protocols recommend that laboratory treatability studies be used to give site-specific degradation information. The laboratory studies will provide information concerning the types of biodegradation that occurs naturally at the site, and provide further insight into the use of specific amendments. These protocols recommend that both soil and groundwater samples be tested.

Two types of laboratory treatability tests may be performed: microcosm bottle studies and soil column studies. The ESTCP and AFCEE protocols recommend a microcosm bottle study (Morse et al., 1998; Air Force Center for Environmental Excellence, 1998). This type of study is relatively simple and useful for screening many variables, such as several potential nutrients. The General Electric Research and Development Center recommends the use of column studies along with microcosm studies because the column studies more closely approximate groundwater flow conditions and can establish segregated environmental zones along the length of a column (Harkness et al., 1998).

### 4.2.1 Anaerobic Laboratory Treatability Studies

Standard soil sampling procedures such as split spoon or coring can be used to collect the soil sample. Harkness et al. (1998) use 4 inch diameter steel Shelby tubes for soil sampling. It is important to immediately encase the sample in Teflon™ sheets or wax to provide an airtight seal. Soil samples can then be stored and transported in 1 qt. canning jars. Soil should be added to the jars and filled with groundwater from the site. The jars are topped with groundwater to minimize bubbles. Alternatively, the jars can be filled in a nitrogen gas environment to prevent exposure to oxygen (Harkness et al., 1998). The samples should be cooled to 4°C with ice or frozen gel packs. Shipment to the laboratory should occur as quickly as possible.

Groundwater should be collected in the same manner as standard groundwater sampling for VOCs, without acid preservatives. They should be stored at 4°C and transported as soon as possible. The ESTCP Protocol recommends that anaerobic microcosm studies be performed using 160 ml serum



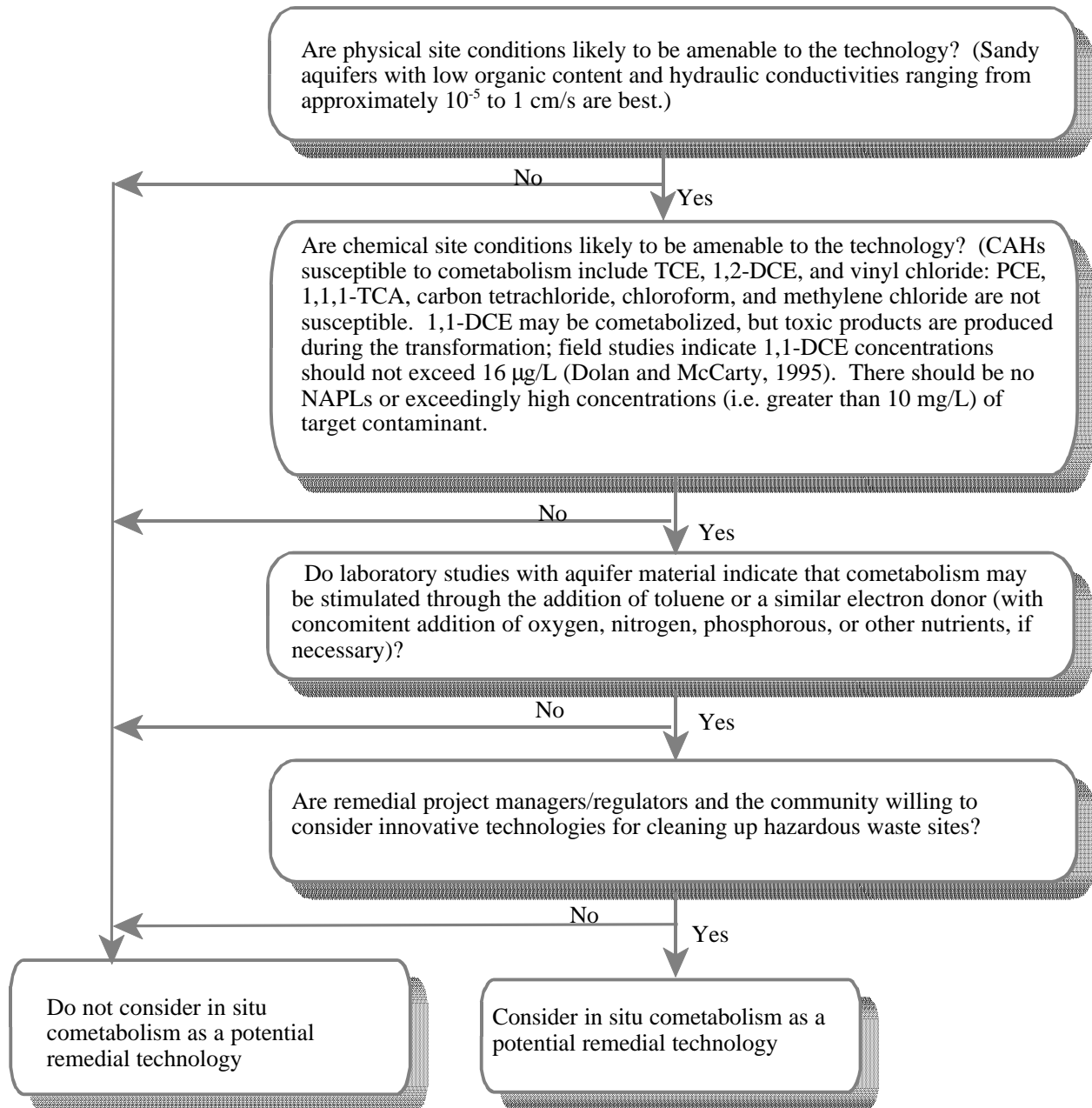

Figure 7. When to consider using in situ cometabolism as a potential remedial technology for cleaning up chlorinated solvents in groundwater (From AFCEE, 1998).

bottles with Teflon™ lined butyl-rubber septa. A mixture of 50 g of soil and 50 ml of groundwater is recommended by Morse et al. (1998) for each microcosm.

The microcosms are prepared under an oxygen-free environment. Morse et al. (1998) recommends using a 1-3% H<sub>2</sub> (balance N<sub>2</sub>) environment. It is important to maintain a limited pH range (6-8 is recommended) by using a NaHCO<sub>3</sub> buffer or by raising or lowering CO<sub>2</sub> content. The ESTCP Protocol recommends a minimum of 7 microcosm bottle sets (Table 8) to evaluate a variety of conditions and different amendments schemes. Chlorinated solvents may or may not need to be added, depending on the ambient levels of chlorinated solvents already present. An abiotic test on a sample, with organics removed with repeated autoclaving, will determine what would happen without native or added bacterial populations or amendments. A biotic control is one in which nothing is added to the site samples, to determine what will occur under natural conditions. Other bottles will test various substrate amendments such as yeast extract, lactate, butyrate, methanol, and lactate/benzoate mixtures.

Microcosms are incubated at 20°- 25° C and monitored at a maximum rate of once per week. They should be monitored for field parameters such as temperature, pH, ORP, as well as supplied

Table 8. Conditions to be examined in Microcosm Bottle Studies. From Morse et al. (1998).

Bottle Set	Donor	Yeast Extract Addition (20 mg/L)	Vitamin B <sub>12</sub> Addition (0.05 mg/L)
1	None (Autoclaved Abiotic Control)	No	No
2	None (Biotic Control)	No	No
3	None (20 mg/L Yeast Extract)	Yes	Yes
4	Yeast Extract (200 mg/L)	No	Yes
5	Lactate (3 mM)	No	No
5	Lactate (3 mM)	Yes	No
5	Lactate (3 mM)	No	Yes
5	Lactate (3 mM)	Yes	Yes
6	Butyrate (3 mM)	Yes	Yes
7	Lactate/Benzoate Mixture (1.5 mM each)	Yes	Yes

mM=millimole

substrate, chlorinated solvents, volatile fatty acids, methane, ethene, carbon dioxide and other important gases, BTEX compounds (where present at site), and inorganics such as chloride. Iron, reduced iron, manganese, and other metals may also be useful analytical parameters.

Harkness et al. (1998) describe a process for column studies that they used to evaluate a site in Kansas for an *in situ* bioremediation project (Fig. 8). The columns are glass chromatography columns with Teflon end caps fitted with butyl rubber septa sampling ports. Columns are covered with aluminum foil to inhibit photosynthesis. Groundwater is pumped through the bottom of the column using a metering pump after being filtered, autoclaved, and sparged with nitrogen. Substrate and nutrients are added directly to the Tedlar bags prior to injection. The bags are under a nitrogen gas environment to prevent oxygenation. Pumping rates vary from 0.05 to 0.1 ml/min. In their study, Harkness et al. (1998) evaluated sodium lactate and methanol as substrate amendments.

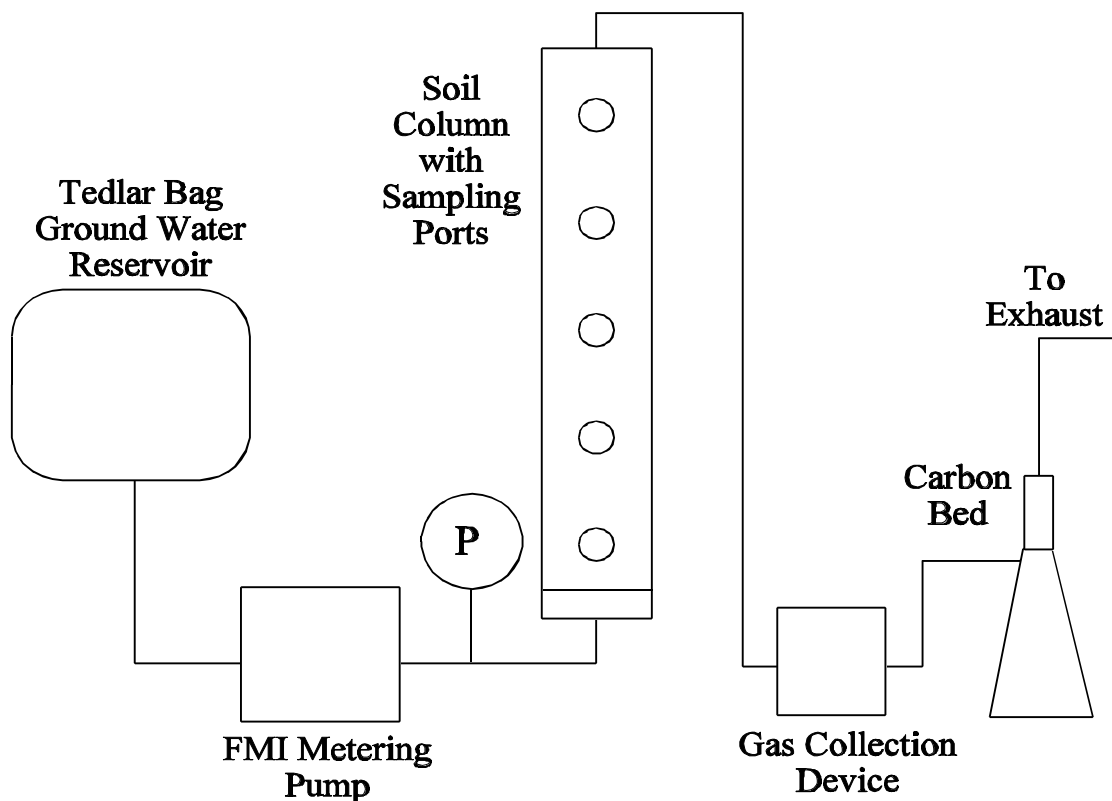

Figure 8. Schematic of soil column set-up. Modified from Harkness et al. (1998).

---

---

#### 4.2.2 Cometabolic Laboratory Treatability Studies

Microcosm or column studies are particularly important for aerobic cometabolism sites. Unlike anaerobic reductive systems, it is very difficult to demonstrate that treatment is responsible for any reduction of contaminated levels, without direct microbial evidence. For aerobic cometabolic systems, the AFCEE guidance document recommends the use of a slurry microcosm. It has been applied at Edwards AFB and Moffett Federal Airfield (Jenal-Wanner and McCarty, 1997). The slurry microcosm uses a lower solid to liquid ratio compared to standard column studies (i.e. Harkness et al., 1998). The slurry allows for total biomass concentration determination, which is difficult in standard column studies. The AFCEE guidance recommends that laboratories specifically equipped to perform the column studies, such as the one at Oregon State University, be used (Air Force Center for Environmental Excellence, 1998).

When sampling for a cometabolic microcosm study, a 4 cm diameter sterile steel cylinder is driven into a 5 cm diameter, 15 cm long core, and the material is scraped into a sterile glass bottle. The material is mixed with 100 ml of filter-sterilized groundwater, then distributed to eight sterile 65 ml screw cap bottles. These are filled with filter-sterilized oxygen-saturated groundwater. The microcosm bottles are capped with Teflon-lined silicon septa and screw caps. An important distinction between sampling for a cometabolic microcosm study and an anaerobic one is that the sample should be oxygenated in a cometabolic microcosm study, but anoxic in the anaerobic microcosms or column samples.

The AFCEE guidance (Air Force Center For Environmental Excellence, 1998) recommends that both phenol and toluene be tested in the slurry microcosms. 300 ml of 19 millimoles (mM) phenol and 700 ml of 6 mM toluene stock solution are added to two of the microcosms in three pulses. This is because of toxicity effect by the substrates. The microcosms are spiked with an appropriate concentration of stock TCE solution (1 mM is recommended). The microcosms are agitated in a dark environment for the incubation period.

Before and after incubation, microcosms are sampled for dissolved oxygen, substrate, and chlorinated solvents compounds. These analyses yield rate information concerning primary substrate utilization, bacterial yield, and contaminant utilization.

#### 4.2.3 Analyses

Cheap and convenient analytical methods for volatile organic samples are required for microcosm or col monitoring analyses. Morse et al. (1998) and Harkness et al. (1998) recommend headspace analyses with gas chromatography (GC). A flame ionization detector (FID) can be used for concentrations greater than 5 ppb. However, electron capture detectors (ECD) may be needed to provide analyses of other constituents. H<sub>2</sub> analyses will require the use of a reduction gas detector (RGD) for low concentrations or a thermal conductivity detector for higher concentrations. Volatile fatty acids can be measured by aqueous injection to GC using an FID for detection. Lactate and benzoate, the common substrates in the ESTCP Protocol, can be measured with high-performance liquid chromatography (HPLC) with ultraviolet (UV) detection (Morse et al., 1998). Harkness et al. (1998) also measure pH, and ORP with microprobes inserted directly into the soil columns. They determined anions such as chloride, bromide, phosphate, ammonia, and sulfate using HPLC.

Soluble iron is normally determined using a Diode-Array Spectrophotometer. Carbon dioxide, methane, ethane, and ethene are analyzed using gas chromatography with a thermal conductivity detector.

Microbiological assessment can be made on microcosm samples to determine the presence and numbers of various microbial populations. This is recommended for sites in which initial site characterization suggests a lack of biodegradation, or in which microcosm results are confusing. One method is the most probable number (MPN) assays. MPN assays may yield useful information concerning the abundance of methanogens, H<sub>2</sub>- PCE/TCE dehalogenators, and yeast extract using dehalogenators. A detailed discussion of MPN is given by Maymo-Gatell et al. (1995).

#### 4.2.4 Evaluating Laboratory Treatability Results

The laboratory treatability results should be thoroughly evaluated to determine under what conditions degradation products have been produced, the rates of degradation, and the paths of degradation. Quality control of the procedure using laboratory validation of analytical results, and by conducting mass balances of parent and daughter compounds, input and output masses of compounds (in the column studies), should be performed if appropriate, MPN assay results should be compared to the degradation paths and kinetics observed in the treatability tests.

Based on this evaluation and site characterization results, a decision will be made on whether to proceed with a field pilot study. The laboratory results should help refine the project goals. For example, it may be determined that degradation to cDCE is feasible for the field pilot, but that the original goal of complete degradation is not likely to occur. A contingency or follow-up remedial step may then need to be considered.

### **4.3 Field Pilot Test Phase**

Initial preparations for the field pilot should be made as soon as site characterization indicates favorable conditions are present. The critical steps in the pilot test include:

- permitting and regulatory acceptance
- preliminary site selection
- focused hydrogeologic study
- engineering design
- test phase
- evaluation

Regulators will likely require work plans for each major phase of the pilot study, including the hydrogeologic investigation, the engineering design, and each major phase of field testing.

---

---

#### 4.3.1 Permitting and Regulatory Acceptance

Significant regulatory barriers may be present for some EISB projects. Therefore, preparations should be made as soon as possible to begin the regulatory permitting and acceptance process. Some of the permits and land disposal restrictions (LDR) compliance that may be required for the project are discussed in more detail in section 3.0 and in Table 5. Although RCRA and CERCLA sites may have permit waivers for activities conducted entirely on site, the substantial requirements for permitting must still be achieved. This means close coordination with state and federal permitting officers.

For aerobic cometabolism sites involving the injection of toluene, phenol, or other RCRA regulated compounds, it will be necessary to provide convincing information that there will be sufficient electron acceptors provided with the injection, or currently within the aquifer to effectively degrade these compounds without significant transport (i.e. McCarty et al., 1998).

If the EISB project involves the recirculation of contaminated groundwater, a determination will need to be made by the appropriate regulatory agency on whether the recirculation would constitute active management of hazardous wastes. If so, the project will need to use one of the previously discussed regulatory mechanisms to allow the reinjection.

If the system does not require recirculation, but there will be injection of amendments, then a Class V injection permit, or substantial compliance with UIC Class V regulations will be required (Table 5). In addition to regulatory requirements with respect to injection, it may be necessary to consider compliance with air emission, water discharge, or investigation derived wastes requirements. Work plans for the pilot and design studies, including sampling and analysis plans, quality assurance plans, and health and safety plans, will need to be provided to regulators for approval as discussed in Section 4.1.2.

#### 4.3.2 Preliminary Site Selection

Based on site characterization data, a preliminary site should be selected for the field pilot study. The contaminant concentrations should be high enough so that it will be possible to easily see secular trends in contaminant levels, and so that degradation products can be easily detected. The ESTCP Protocol recommends that concentrations should be at least two orders of magnitude greater than the contaminant's detection limit. For most contaminants, that means approximately 100 µg/L or greater. Higher concentration portions of the plume may be more appropriate, if the ultimate goal of the full scale system is source area remediation. However, even if the ultimate goal is to treat very high concentration areas, the initial pilot should probably not be located directly over known DNAPL, and concentrations should be below levels indicative of DNAPL (<1% of saturation). This is because high rates of dissolution of NAPLs could make it difficult to discern effective degradation (Morse et al., 1998).

The location should be in an area in which there is already some geological and hydrogeological control. Hydraulic conductivities should be greater than  $10^{-4}$  cm/s in the contaminated horizon. If possible, lateral heterogeneities in the aquifer should be avoided. Flow velocities of 0.2 to 1 ft<sup>3</sup>/day prior to pumping are recommended by the ESTCP Protocol.

Other considerations should play a role. These include the existence of wells suitable for extraction or injection. Existing infrastructure may help in the engineering design and may play a role in site selection. For example, nearby concrete pads for foundations or vacant portable buildings may be used during the pilot. If hydraulic conductivity tests have been performed in a suitable area, the selection of this area may eliminate the need for further aquifer tests.

#### 4.3.3 Focused Hydrogeologic Study

The focused hydrogeologic study is designed to determine as much information about groundwater flow and contaminant fate and transport at the selected site as possible. The study may include aquifer parameter testing, tracer tests, and hydrogeologic flow and fate-and-transport modeling.

Unless suitable wells are already present at the proposed location, at least one well will need to be installed for aquifer parameter tests. This well can be later converted to either an injection or monitoring well. It is probably best to delay the installation of other extraction, injection and monitoring wells until hydraulic parameters have been established.

Aquifer parameter tests from the selected site should include either slug tests or down hole velocity measurements. Slug tests are cheaper, and most drilling contractors are well equipped to conduct these. As previously mentioned, slug test results should be used with caution. They may yield minimum hydraulic conductivity results because of casing and packing effects. Slug tests should be conducted according to ASTM D4044 and D41014 (Table 7).

As previously discussed, sensitive borehole flow meters have become commercially available, allowing multiple level velocity measurements within a single well (Molz et al., 1994). These provide measurement of flow rates under ambient and constant pumping rates. Although there will be significant error in calculation of hydraulic conductivity versus depth, the procedure will at least delineate relative changes in hydraulic conductivity, and thus give valuable information concerning aquifer heterogeneities. Porosity estimates should be made visually or by the procedure of Fetter (1994).

The groundwater flow direction should be determined by measuring water levels from wells screened within the aquifer of interest in the immediate area of the selected site. A hydraulic gradient should be estimated graphically from a piezometric contour map of the area. The groundwater flow velocity should then be calculated using the estimated porosity, hydraulic conductivity, and gradient. This flow velocity can be compared with velocities determined from borehole flow meters if available.

Hydrogeologic flow models can provide information for the design of the pilot system and also provide UIC permitting authorities information concerning the area likely to be affected by injection and extraction. Some state UIC programs require hydrogeologic modeling to provide proof of hydraulic containment of the permitted injection system (i.e. Appendix F).

The hydrogeologic modeling will be used to help determine the precise location of injection, extraction, and monitoring wells, and to determine the extraction (if applicable) and injection rate.

The model will also be used to estimate the capture zone or affected portion of the plume, and the rate at which water will escape downgradient from the treatment zone.

The flow model should be a three dimensional finite-difference flow model. The most commonly used is the U.S. Geological Survey model MODFLOW (McDonald and Harbaugh, 1988). Several graphic interface platforms for MODFLOW have been developed. These include Visual MODFLOW marketed by Waterloo Hydrogeologic, The Department of Defense software, GMS, marketed by BOSS International, and Groundwater Vistas marketed by Environmental Simulations, Inc. These software packages all include transport models such as RT3D or MT3D, and a particle tracking module, such as MODPATH. Chemical fate and transport or reaction path models, such as RT3D, can estimate the effects of degradation reactions, dispersion, and adsorption, and may be useful. However there is currently some uncertainty as to how well these programs can predict complex degradation mechanisms such as those affecting chlorinated solvents.

The models should be based on sound site conceptual models and realistic boundary conditions. Natural boundaries should be selected if at all possible. The model should be carefully calibrated for varying hydraulic parameters and stress conditions, such as pumping and injection rates. Communication with underlying or overlying aquifers may need to be evaluated. Models should follow ASTM guides where appropriate. These include D5447 (site specific models), D5490 (calibration), D5609 (boundary conditions), D5610 (initial conditions), and D5611 (sensitivity analysis) (Table 7).

The most important design information provided by the hydrogeologic modeling includes the appropriate extraction and/or injection rate, the hydraulic retention time established by this rate, and the aerial extent of the treatment zone (Fig. 9). As the extraction-injection rate for the dual-well recirculation system is increased, the zone of influence (treatment zone) expands (Fig. 10). Too high a rate of injection/extraction could cause unnecessary spreading of the contaminant zone. An extreme example of this problem is illustrated in Figure 11. An injection well located close to a groundwater divide creates a mound in the piezometric surface such that it encompasses the divide and allows contaminated groundwater to cross the divide.

Transient models using particle trace subroutines such as MODPATH can determine the hydraulic retention within the treatment zone. The optimum hydraulic retention time should be approximately 30 days (Morse et al., 1998). This will allow time to observe changes in contaminant concentrations as water moves through the treatment zone. A longer time period will make the field pilot extend beyond six months to a year, which is the typical duration of a field pilot.

In some cases, a dual vertical well recirculation system is not intended to provide closed recirculation. Systems designed to allow capture of some upgradient fluid and release of treated groundwater



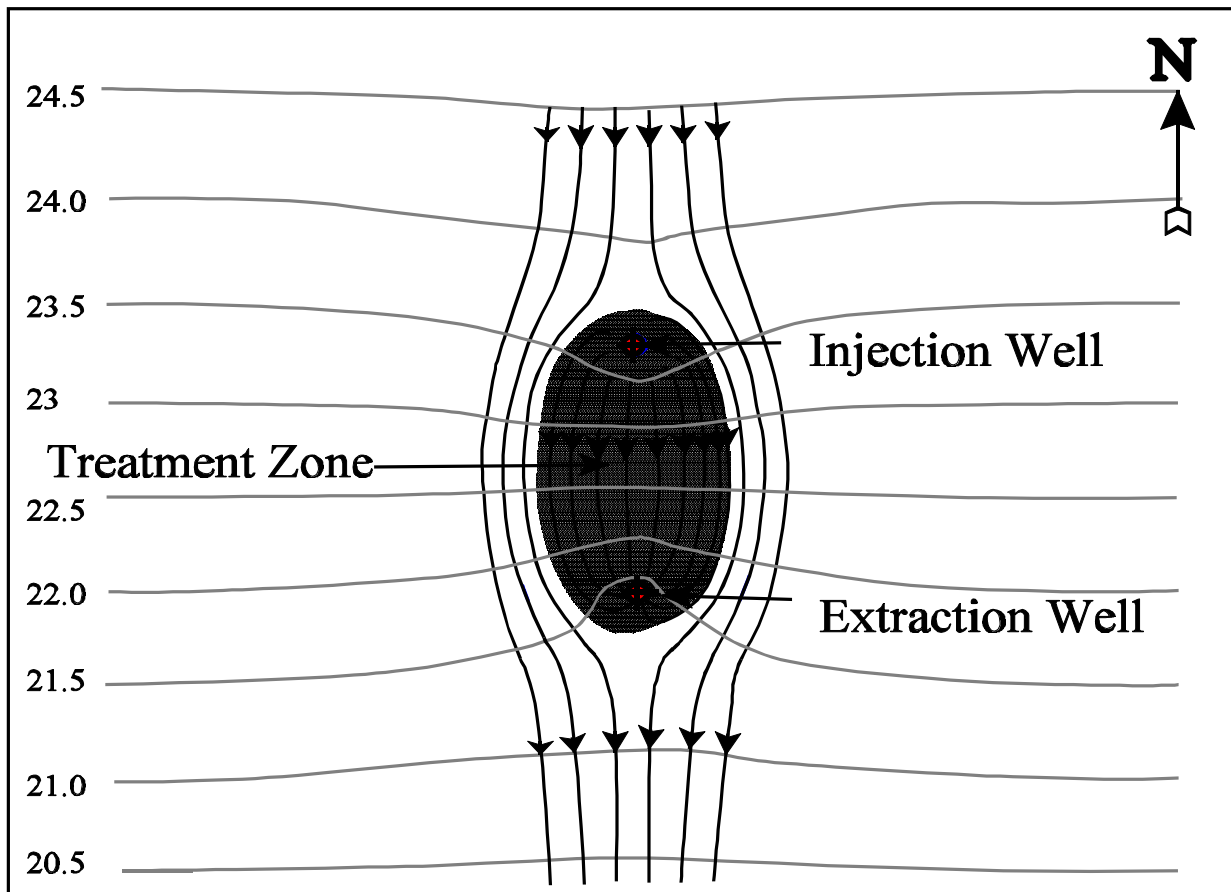

**Figure 9. Hydrogeologic model of an in situ bioremediation recirculation system. The shaded lines are piezometric surface contours. The black lines represent particle pathway traces. The shaded zone represents the effective treatment zone. Contaminated groundwater within this zone will pass through the recirculation system one or more times. Model assumes a uniform thickness unconfined aquifer and constant head boundaries on the north and south margins.**

downgradient of the system can do so by orienting the wells at some angle to the natural hydraulic gradient. The AFCEE guidance document on cometabolic systems recommends an orientation perpendicular to the gradient in order to achieve some pass-through (Fig. 12).

Vertical recirculating wells have slightly different groundwater modeling requirements. Rather than providing a closed-loop system, the vertical recirculation wells continually “leak” significant quantities of water downgradient. Groundwater models can be used to establish the most appropriate lateral spacing of vertical recirculation wells based on their upgradient partial treatment zones (Fig. 13c). Two or more rows of these wells should be positioned with alternating centers. The number

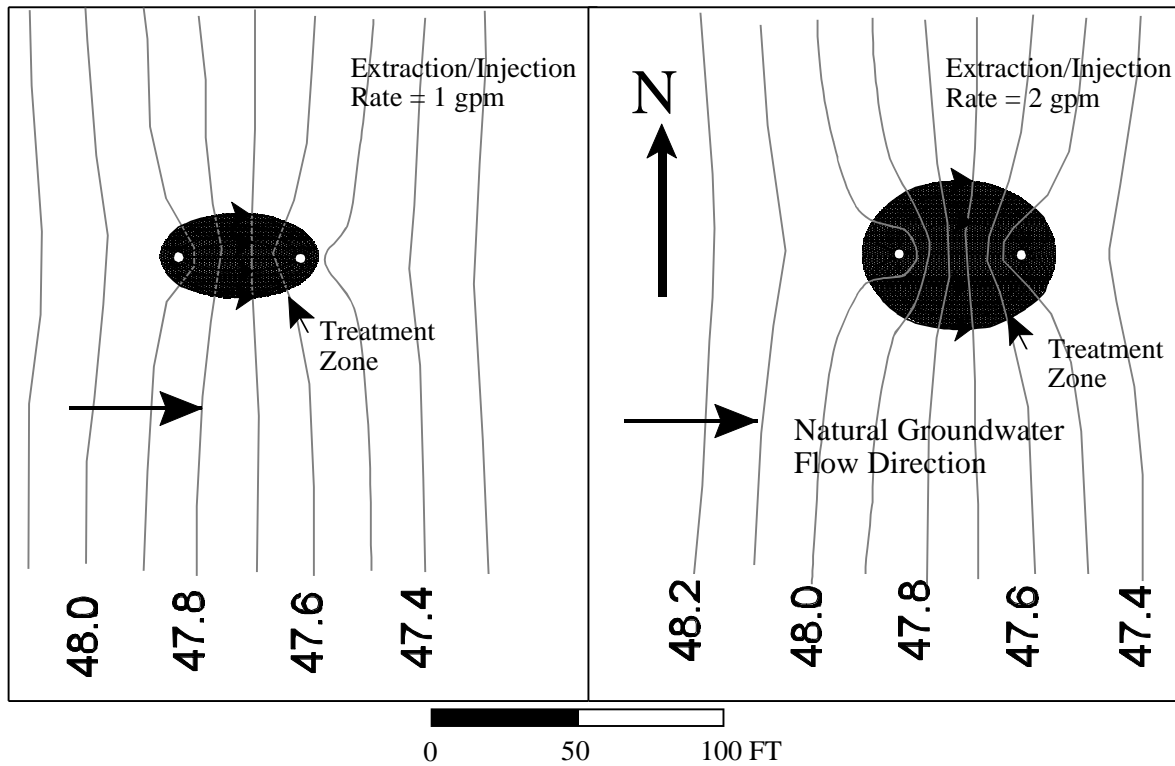

Figure 10. Hydrogeologic modeling results showing the effects of increasing extraction/injection rate. Model is for unconfined flow in a uniform aquifer 100 feet thick with hydraulic conductivity of 0.005 cm/s. Boundary conditions include constant heads on the east and west margins.

of rows depends upon the required residence times and the rate at which the wells are pumping/injecting.

Morse et al. (1998) recommend a tracer study as part of the initial phase of the pilot test. However, a tracer study may also be conducted prior to the installation of the pilot to help in the design of the system. Sodium bromide is normally added at about 100 times its detection limits. The mass of injected sodium bromide is compared to the calculated mass of recovery from downgradient well(s). If more than one well recovers sodium bromide, the relative proportion can be used to better establish the hydraulic gradient. Lack of good recovery can indicate an inaccurate delineation of the hydraulic gradient or unpredicted lateral or vertical heterogeneities. The time to inflection in a plot of tracer concentration versus time in the recovery well should be used to calculate the travel time under natural flow conditions. There was initial regulatory objection to the use of sodium bromide at the cometabolic EISB system at Edwards Air Force Base, CA, because of the possible production of bromate and brominated organic acids (Goltz et al, 1998). These concerns were eventually overcome and the tracer study was allowed to go forward.

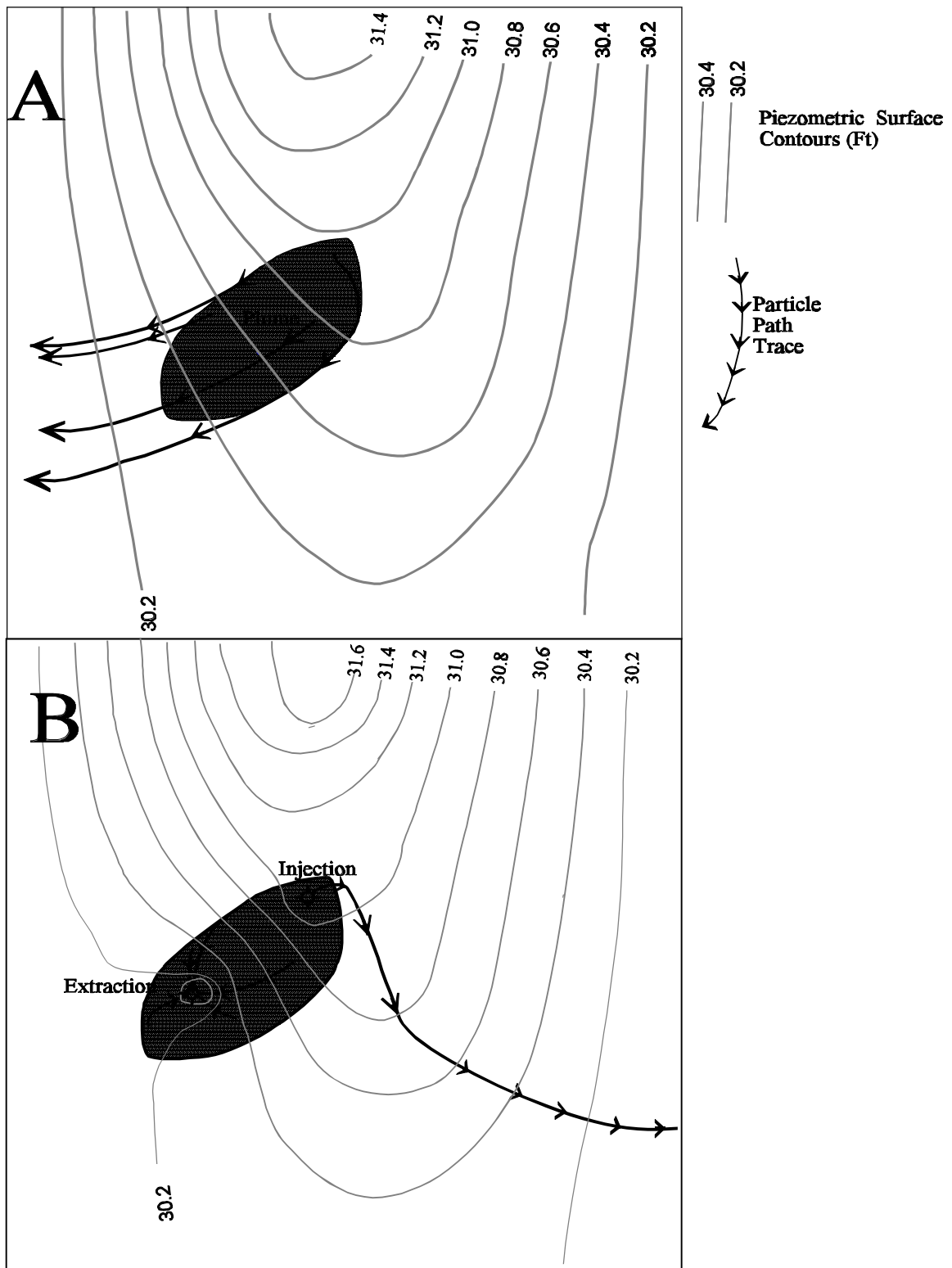

Figure 11. Example of loss of plume containment from excessive pumping of injection-extraction recirculation system. A) Plume located near groundwater divide. B) Excessive pumping in the upgradient injection well causes spread of the plume across the groundwater divide.

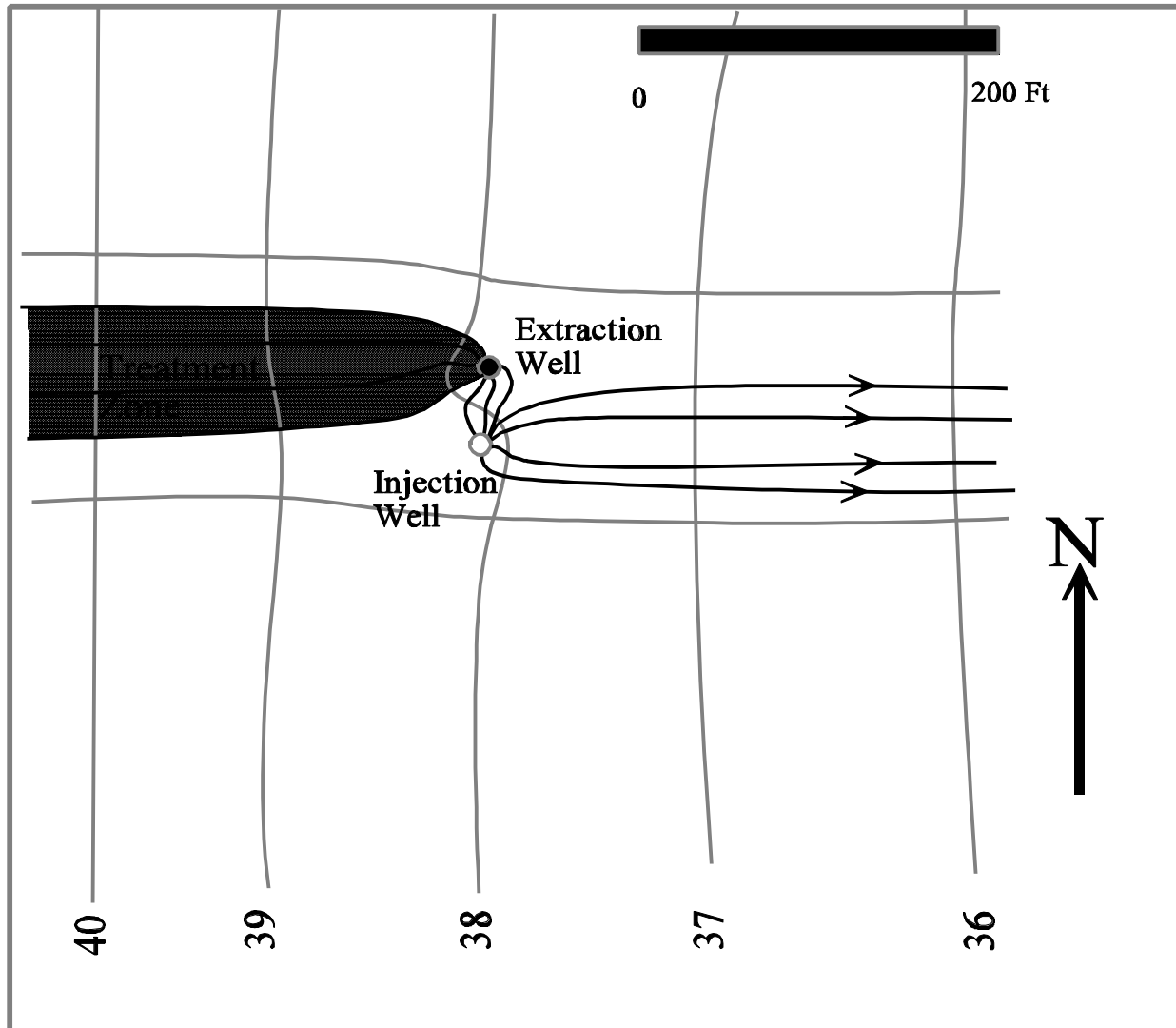

Figure 12. Hydrogeologic model using a dual vertical well recirculation system which is oriented perpendicular to the hydraulic flow direction. This system is a partial pass-through system in that a significant volume of treated groundwater leaves the system from the injection point. Lines with arrows indicate particle path traces. Groundwater model assumed a uniform unconfined 60 ft. thick aquifer with assigned constant head boundary conditions on east and west margins. Such a system is recommended for cometabolic biodegradation systems in non-anisotropic aquifers by the AFCEE guidance manual (Air Force Center for Environmental Excellence, 1998).

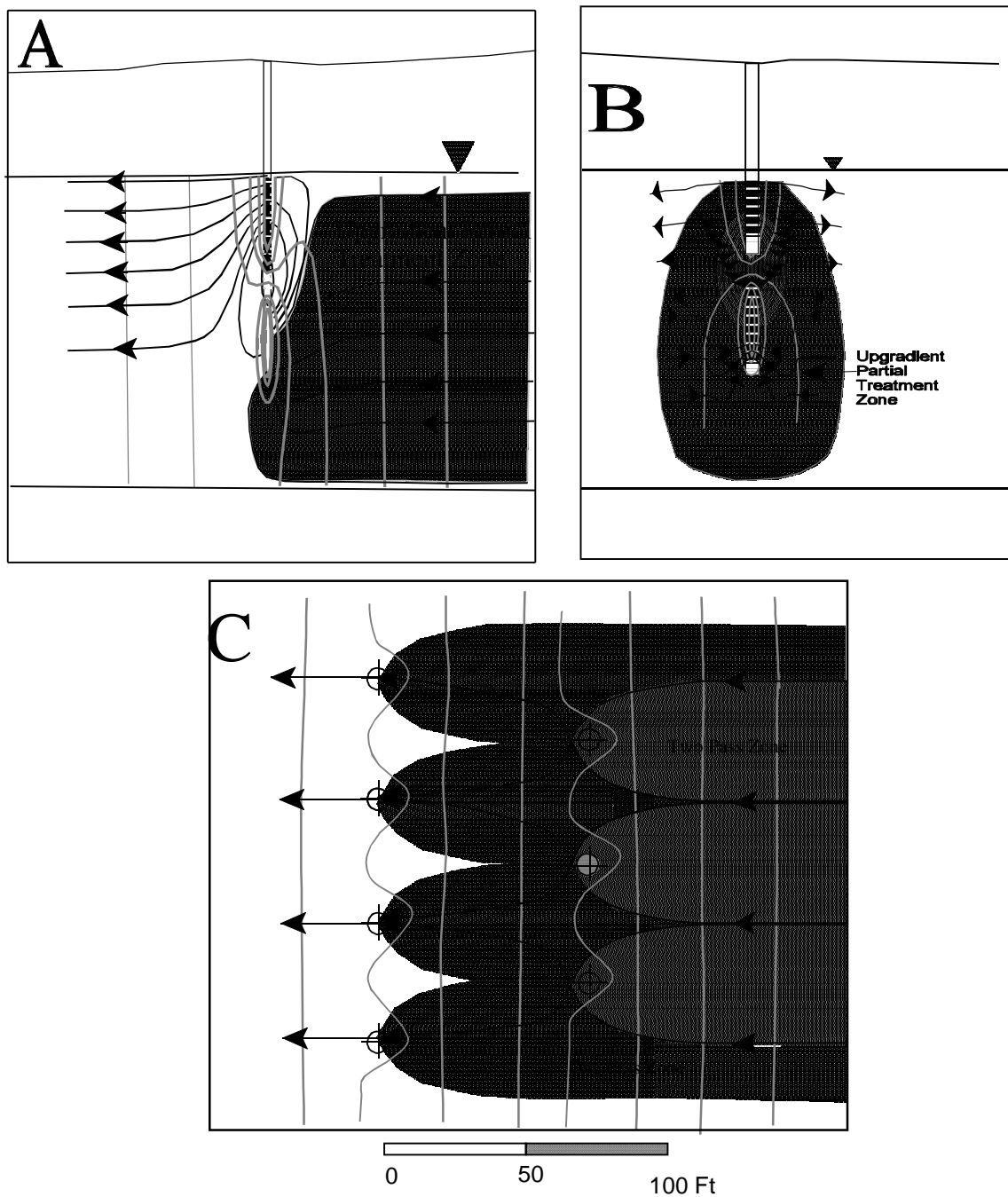

Figure 13. Hydrogeologic model of vertical recirculating well. A) is a cross section oriented parallel to groundwater flow. Groundwater enters in a lower screen and exits from an upper screen. B) is a cross section perpendicular to flow. It shows the width of the upgradient partial treatment zone. C) is a map showing two rows of vertical recirculation wells, as well as upgradient treatment zone with a minimum of one pass (lighter) and two passes (darker).

#### 4.3.4 Engineering Design

Regulators may require one or more remedial design or removal design reports. 30%, 60%, 90%, and 100% designs are common. The design phase should incorporate the extraction/injection strategies of the hydrogeologic modeling study.

Most dual-well recirculation pilots have one row of three or more extraction wells upgradient from three rows of injection wells. Major consideration for the design include the layout of plumbing and other infrastructure, the method and schedule of nutrient addition, the type of extraction and injection systems, and the monitoring design and schedule.

Above ground components, including storage containers, plumbing components, and a source of electric power, will all need to be incorporated into engineering designs (i.e. Fig. 14). Site specific conditions will guide this design. For example, the depth of plumbing and use of portable buildings to house storage containers will depend upon the expected weather conditions at the time of installation. The size of containers and plumbing components will depend on the amount and rate of injection/extraction. For anaerobic systems, solutions should be prepared in oxygen free environments (N<sub>2</sub> gas) and sealed in airtight collapsible containers (Morse et al., 1998).

Pumps will be selected based on the depth to screened interval and the required rate of pumping. Chemical metering pumps may be used to deliver amendments at a desired rate (Fig. 14). Flexible tubing may be used between storage containers and metering pumps. Rigid pipe such as PVC or steel should be used for plumbing beyond the metering pumps. Piping will be sized to accommodate desired flow rates (Morse et al., 1998).

A static mixer may be used to combine the nutrients, a tracer, and extracted groundwater prior to injection. After mixing, valves within the system will control the flow rate and should be capable of matching injection and extraction rates. Morse et al. (1998) recommend that flow meters be selected so that the design flow rate is within 60% of the meters range.

Pressures should be measured close to the injection point within the delivery line. Specification of pressure(s) may be required in Class V permits (See Appendix F). Many states have regulations regarding the injection pressures that will be allowed. Pressure build-up indicates the possibility of porosity clogging by gas bubbles, biomass, or inorganic precipitates in the system (Morse et al., 1998).

For both anaerobic and cometabolic systems, pulsing of substrate is recommended. This accomplishes two things. First, it inhibits bioclogging of porosity adjacent to the injection point. Secondly, the pulsing provides limited slugs of substrate that can be periodically depleted, thereby reducing the competitive inhibition of the primary substrate on the targeted chlorinated solvent compounds.

The ESTCP Protocol considers the design parameters for a very small field pilot test. It recommends a system with three 2 inch injection wells spaced along 12 inch centers, one 2 inch extraction well (gradient well) centered downgradient from the injection wells and one 4-inch extraction well

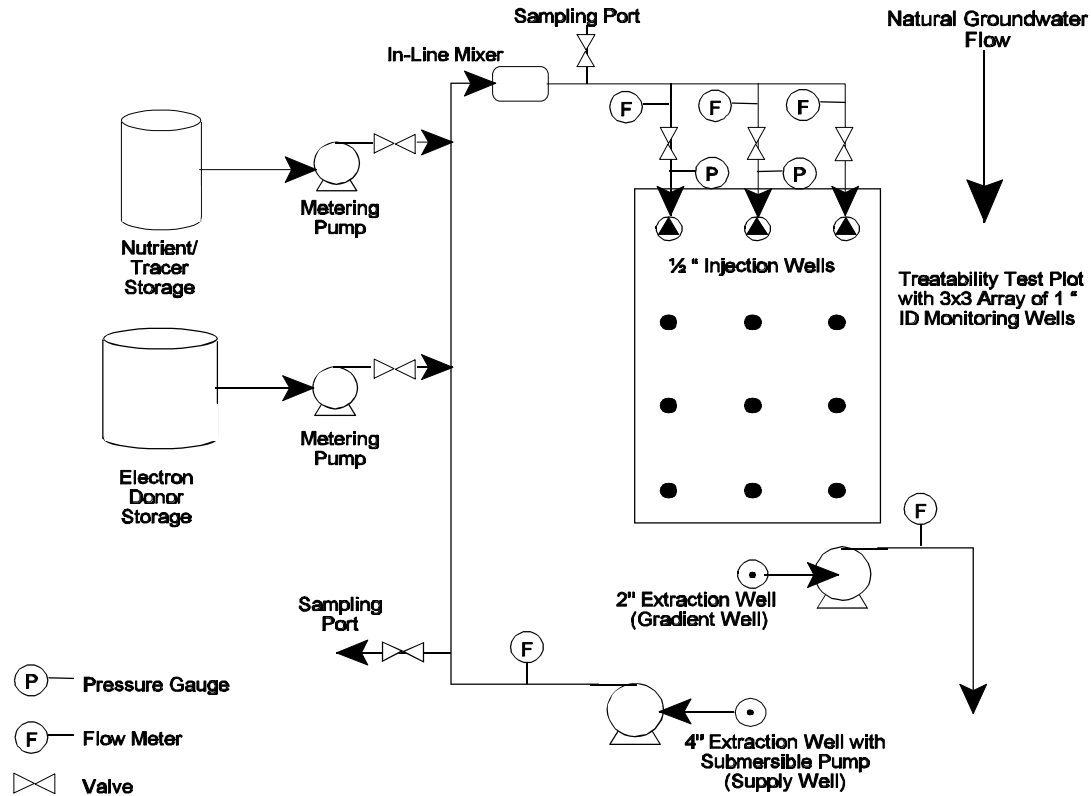

Figure 14. ESTCP Protocol Test Plot Layout. From Morse et al. (1998).

centered downgradient from the 2 inch well (Fig. 14). The system should be oriented as close to parallel to the natural flow direction as possible to increase the efficiency of recirculation. The spacing between injection and extraction should be the travel distance of groundwater in 35 to 40 days under natural flow conditions. Morse et al. (1998) recommend a distance of less than 40 feet if possible.

Most other field pilots for reductive anaerobic bioremediation have been larger than the one suggested by Morse et al. (1998). For example, the field pilot at Dover AFB is 60 feet x 40 feet. Others, such as the one designed by Litherland and Anderson (1997) are much larger. The advantage of smaller systems is cost and more timely results. The disadvantage is that it is more difficult to judge the potential success of a large scale system.

The ESTCP Protocol calls for three rows of monitoring wells between the injection and extraction wells (Fig. 14). State and federal regulators will probably require additional monitoring wells downgradient of the extraction wells and cross gradient and upgradient from the injection well, in order to assure hydraulic gradient control of the system. All wells should be installed according to state guidelines and ASTM standards should be followed where appropriate (Table 7).

---

The ESTCP Protocol is designed for a multi-well recirculation system in which containment within a nearly closed-loop treatment zone is a goal. This is probably the most common situation for design of EISB systems. However, if the goal is to provide a “flow through” treatment zone, where contaminated groundwater is allowed to enter, pass through the system and mix with nutrients, and then pass out of the system, the design options will be different. For dual-well recirculation systems, wells can be oriented at an angle to the hydraulic gradient as recommended in the AFCEE guidance document (Fig. 12). A system in which the extraction well is upgradient and the injection well is downgradient was used at a carbon tetrachloride (CT) site in Schoolcraft, Michigan to allow for some pass-through of groundwater (Criddle et al., 1997; Fig. 15). Water mounds in the downgradient system causing reverse flow. There is continual leakage from the downgradient portion of the plume, but a substantial portion of the water passes through the system at least once. Other alternatives for pass-through systems include direct injection through one or more injection wells using gravity or pressure injection (Fig. 4c), a series of multiple rows of vertical recirculation wells (Fig. 4d, 13c), or a passive reactive well system (Fig. 4f).

Fouling of porosity by the activity of microorganisms near injection points has been observed at a number of sites. This is referred to as “biofouling” or “bioclogging”. Bioclogging can be detected by increases in pressure and decreases in flow rates within the system. Routine injection well cleaning and surging will help unclog porosity. Careful calculation of amendment requirements, and avoidance of excessive amendment addition will help to minimize fouling. Pulsing of nutrients into the system may also help to minimize bioclogging. The AFCEE guidance document for Cometabolic Biodegradation (AFCEE, 1998) recommends hydrogen peroxide as an alternate, and possibly a temporary electron acceptor amendment at aerobic cometabolism sites, in order to kill and remove biomass adjacent to the injection point.

The amount and concentrations of nutrients will be determined based on the results of microcosm or column studies, and the estimated mass of contaminants within the treatment zone. As previously mentioned, it is important to not add too much substrate or nutrients, so as to avoid bioclogging. For most systems, it will be necessary to perform some sort of system startup phase prior to full activity of the pilot system. The purpose of this phase is to acclimatize or enhance the activity of the microbial populations to accommodate the added amendments. The AFCEE guidance manual recommends that the amendments be added incrementally for a short period (approximately 1 week). A rapid decline in amendments following this period indicates suitable degradation. After amendment levels approach baseline concentrations, another round of amendment addition at a higher rate is recommended (approximately twice the original concentrations) followed by a monitoring period. The process may need to be repeated until a suitable degradation rate and amendment addition rate can be established. Tracers, such as sodium bromide, may be added with the amendments at approximately 100 times the detection levels in order to determine the recovery efficiency in the downgradient extraction wells, and to determine travel times.

For cometabolic systems, the AFCEE guidance manual (Air Force Center For Environmental Excellence, 1998) recommends that if toluene is indicated as the preferred substrate from the slurry microcosm tests, it should be added so as to achieve a time-averaged concentration of 7-15 mg/L. This is a concentration determined from toxic effects data (Lederer, 1995). It is likely that toluene



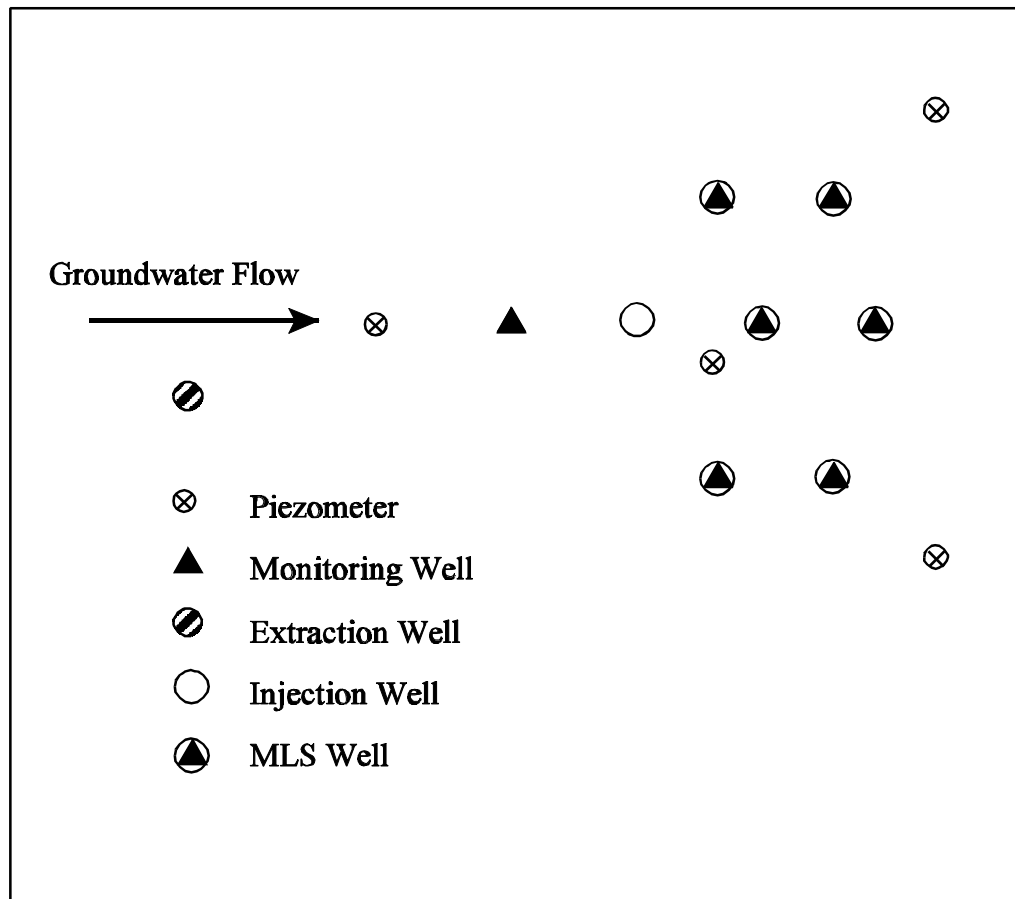

Fig. 15. System configuration for bioaugmentation study, Schoolcraft, MI. Modified from Criddle et al. (1997).

concentrations greater than 1 mg/L will achieve biodegradation. To achieve these concentrations, the toluene is pulsed for 30 minutes every 8 hours. The pulsing helps to distribute the toluene more uniformly and reduce bioclogging. For Edwards AFB, 31 mg/L dissolved oxygen is required to degrade the maximum time-averaged toluene concentration of 15 mg/L (Hopkins and McCarty, 1995). Additional oxygen is maintained to satisfy any ORP buffering capacity of the aquifer. Both oxygen and hydrogen peroxide may be used, with the hydrogen peroxide added to reduce bioclogging near the injection points.

Each monitoring point should be sampled and analyzed on a weekly basis. However this may depend upon the system and flow rates. The same parameters that were used for the laboratory treatability

**Table 9.** Lines of Evidence for Performance Evaluation of Cometabolic Systems. Modified from AFCEE (1998).

Lines of Evidence	Type of Data to Necessary to Demonstrate
Reduction of Mass of Contaminants	1) Temporal and spatial reductions in concentrations. 2) Integration of extrapolated concentration measurements for the system. 3) Comparison of concentrations through more than one recirculation cycle before and after addition of biostimulants. 4) Comparison of mass leaving injection points and arriving extraction points.
Microbiological Activity Linked to Degradation	1) Microcosm or column studies which demonstrate cometabolic activity. 2) Calculated field degradation rates are consistent with microcosm or column studies. 3) Biomass of methanogens in the field correlate with zones of contaminant depletion.
Contaminant Disappearance Linked to Cometabolic System	1) Statistically link contaminant depletion with substrate depletion. 2) Statistically link temporal changes in contaminant concentration with initiation or cessation of substrate addition. 3) No evidence for anaerobic conditions (including reductive degradation products, field parameters indicating low ORP, etc.)

study should be analyzed during the pilot. The analytical methods should be EPA recognized methods where appropriate, such as those previously discussed for the site characterization or laboratory study.

#### 4.3.5 Evaluating Pilot Test Results

Demonstration of successful degradation of chlorinated solvents from field data at cometabolic sites can be difficult. This is because there are no easily measured degradation products such as lesser chlorinated aliphatics associated with the degradation process. However, there are several methods to determine an apparent loss of contaminants (Table 9). In a closed (or nearly closed) recirculation system, a mass balance can be performed to determine the mass of contaminants leaving the injection point and arriving at the extraction point. This was shown to demonstrate mass removal of chlorinated solvents at Moffett Federal Airfield, California (Hopkins and McCarty, 1995). However convincing these types of data may be in demonstrating mass removal, they alone cannot demonstrate the mechanism by which mass is lost. For this, conclusive microcosm data together with evidence,

which links contaminant disappearance to specific elements of the cometabolic system, must be demonstrated.

For anaerobic reductive systems, the field pilot should compare calculated mass loss of primary contaminants with their degradation products (including  $Cl^-$  and ethene). The degradation reactions and rates should be compared with laboratory treatability studies. Significant variation from laboratory treatability results may indicate the presence of physical, chemical, or biological complexities that may require further field or laboratory tests. Good agreement could result in a decision to go forward with a full-scale system.

## **5.0 CONCLUSIONS AND RECOMMENDATIONS**

EISB technology is still very much in its infancy. It currently encompasses a great diversity of degradation processes, delivery systems, and amendments. It is likely that further testing and deployment will significantly reduce the diversity of EISB systems in the near future. However, the effectiveness of a particular EISB technology has been shown to be very site specific. For those who are currently considering EISB, we recommend considering a variety of delivery and degradation systems for their sites. Both of the major types of degradation mechanisms in EISB systems have been shown to clearly reduce contaminant levels. Cometabolic systems may be most suited to aquifers that are already oxidizing. Anaerobic reductive systems are most likely to succeed where there is already substantial organic carbon and reducing conditions. It is likely that most of the delivery systems that we have discussed will continue to be used, because they each were developed to address site-specific hydrogeologic conditions.

Any EISB pilot should be preceded by, at the very least, an extensive site assessment and a hydrogeologic study to determine the geochemical, geological, and hydrogeological conditions. This will help determine if a site is conducive for a successful EISB pilot. It is also strongly recommended that the pilot be preceded by at least some laboratory treatability study similar to those presented in this document. The need for laboratory treatability studies at every EISB site may diminish as these technologies become more accepted and understood. However for now, they provide an important portion of the evidence to judge the effectiveness of the proposed degradation mechanisms.

Regulators and the public should be involved early and often in the process of implementing an EISB pilot. Researching applicable state and federal regulations very early in the process is extremely critical, as these regulations may represent significant barriers to deploying some EISB projects. In particular, the UIC permitting process and determinations of land disposal restrictions (LDR) for recirculating EISB systems must be started well in advance of the pilot design.

---

---

## 6.0 REFERENCES

- Air Force Center For Environmental Excellence, 1998, *Aerobic Comatabolic In Situ Bioremediation Technology Guidance Manual and Screening Software Users Guide: Installation Restoration Program*, Air Force Center for Environmental Excellence, Brooks Air Force Base, Texas, p.82.
- Becvar, E.S.K., Sewell, G., Vogel, C.M., Gossett, J., Zinder, S., 1997, *In Situ Dechlorination of solvents in saturated soils*, in *The Fourth International In Situ and On Site Bioremediation Symposium*, v. 3, p. 39-44.
- Becvar, E.S.K., Fisher, A., Sewell, G., Magar, V., Gossett, J., Vogel, C.M., 1998, *Enhanced in situ reductive dechlorination*, in Wickramanayake, G., and Hinchee, R., eds., *Remediation of Chlorinated and Recalcitrant Compounds*, Vol. 4, *Bioremediation and Phytoremediation*, Battelle Press, Columbus Ohio, p. 121-128. (Referred to in text as the "ESTCP Protocol")
- Beeman, R.E., Buchanan, R.J. Jr., Biehle, A.A., Lee, M.D., Leethem, J.T., 1998, *Experience with in situ microbial anaerobic reductive dechlorination*, in Sikdar, S.K., and Irvine, R.L., eds., *Bioremediation: Principles and Practice*, Vol. II, *Bioremediation Technologies*, Technomic Publishing Co, Lancaster, p. 303-355. (Referred to in text as Dupont recommendations)
- Bourquin, A.W., Mosteller, D.C., Olsen, R.L., Smith, M.J., 1997, *Aerobic bioremediation of TCE-Contaminated Groundwater: Bioaugmentation with Burkholderia Cepacia PR1301*, in Alleman, B.C., and Leeson, A., chairs, *In Situ and On-Site Bioremediation Symposium*, v. 4, p.513-518. Batelle Press, Columbus, OH.
- Bradley, P.M., and Chapelle, F.H., 1996, *Anaerobic mineralization of vinyl chloride in Fe(III)-reducing aquifer systems: Environmental Science and Technology*, v. 30, no. 6, p. 2084-2086.
- Bradley, P.M., and Chapelle, F.H., 1997, *Kinetics of DCE and vinyl chloride mineralization under methanogenic and Fe(III)-reducing conditions: Environmental Science and Technology*, v. 31, no. 9, p. 2692-2696.
- Bouwer, H., Rittmann, B.E., McCarty, P.L., 1981, *Anaerobic degradation of halogenated 1- and 2-carbon organic compounds; Environ. Sci. Technol.*, v. 15, p. 596-599.
- Bouwer, E.J., 1994, *Bioremediation of chlorinated solvents using alternate electron acceptors*, in Norris, R.D. et al., eds., *Handbook of Bioremediation*: p. 149-175.
- Brown, M.J., McMaster, Michaye, Barker, J.F., Delin, J.F., Katic, D.J., Froud, S.M., 1997, *Passive and semi-passive techniques for groundwter remediation: In Situ and On-Site Bioremediation*, v. 4, p. 181-186.
- Chiu, Y-C., Lu, C-J, Huang, S-Y, 1997, *Anaerobic dechlorination of tetrachloroethylene to ethene using winery microbial consortium*, in Alleman, p. 51-56.
- Christopher, M., Litherland, S.T., O'Cleirigh, D., Vaugh, C., 1997, *Anaerobic bioremediation of chlorinated organics in a fractured shale environment*, in *The Fourth International In Situ and On Site Bioremediation Symposium*, v. 5, p. 507-512.
- Cookson, J.T., Jr., 1995, *Bioremediation Engineering Design and Application*: McGraw-Hill, Inc., p. 524.
- Cox, E.E., McMaster, M., McAlary, Major, D.W., Lehmicke, L., Edwards, E.A., 1998, *Accelerated bioremediation of trichloroethene from field and laboratory studies to full-scale: The First International Conference on Remediation of Chlorinated and Recalcitrant Compounds*, Platform Abstracts.

- 
- Cox, E.E., and Major, D.W., 1993, A Laboratory and Field Assessment of the Potential to Biotransform Trichloroethene in a Deep Aquifer in California: Proceedings of the 3rd Annual Symposium on Groundwater and Soil Remediation, Quebec City, Canada, p. 850199.
- Criddle, C.S., Dewitt, J.T., Grbric-Galic, D., McCarty, P.L., 1998, Transformation of carbon tetrachloride by *Pseudomonas* sp. strain KC under denitrifying conditions: *Appl. Environ. Microbiol.*, v. 64, p. 3240-3246.
- DiStefano, T.D., Gossett, J.M., and Zinder, S.H., 1992, Hydrogen as an electron donor for the dechlorination of tetrachloroethene by an anaerobic mixed culture: *Appl. Environ. Microbiol.*, v. 58, p. 3622-3629.
- DiStefano, T.D., Gossett, J.M., Zinder, S.H., 1991, Reductive dechlorination of high concentrations of tetrachloroethane to ethane by an anaerobic enrichment culture in the absence of methanogenesis: *Appl. Environ. Microbiol.*, v. 57, p. 2287-2292.
- Dolan, and McCarty, P.L., 1995, Methanotrophic chloroethene transformation capacities and 1,1-dichloroethylene transformation product toxicity: *Environ. Sci. Technol.*, v. 29, p. 2741-2747.
- Duba, A.G., Jackson, K.J., Jovanovich, M. C., Knapp, R. B., and Taylor R.T., 1996, TCE Remediation Using In Situ, Resting-State Bioaugmentation: *Env. Science and Technol.*, v. 30, p. 1982-1989.
- Dybas, M.J., et al., 1997, Evaluation of Bioaugmentation to Remediate an Aquifer Contaminated with Carbon Tetrachloride, in Alleman, B.C., and Leeson, A., chairs, *In Situ and On-Site Bioremediation Symposium*, v. 4, p. 507-512. Battelle Press, Columbus, OH.
- Ensign, S.A., Hyman, M.R., Arp, D.J., 1992: *Appl. Environ. Microbiol.*, v. 58, p. 3038-9046.
- Fennell, D.E., Stover, M.A., Zinder, S.H., and Gossett, J.M., 1995, Comparison of alternate electron donors to sustain PCE anaerobic reductive dechlorination, in Hinchee, R.E., Leeson, A., and Semprini, L., eds., *Bioremediation of Chlorinated Solvents*, Battelle Press, Columbus, OH, p. 9-16.
- Fetter, C.W., 1994, *Applied Hydrology*: Merrill Publishing Co., Columbus, OH.
- Freedman, D.L., Gossett, J.M., 1989, Biological reductive dechlorination of tetrachloroethylene and trichloroethylene to ethylene under methanogenic conditions: *Appl. Environ. Microbiol.*, v. 55, p. 2144-2155.
- Gibson, S.A., Sewell, G., 1992, Stimulation of reductive dechlorination of tetrachloroethene in anaerobic aquifer microcosms by addition of short-chain organic acids or alcohols: *Appl. Environ. Microbiol.*, v. 58, p. 1392-1393.
- Gilmore, T., Kaplan, D.I., Oorstrom, M., 1998, Residence Times required for chlorinated hydrocarbon degradation by reactive wells: The First International Conference on Remediation of Chlorinated and Recalcitrant Compounds, Platform Abstracts, B6. Groundwater Circulating Wells Platform.
- Glass, D.J., Raphael, T. Benoit, J., 1997, International Bioremediation: Recent Developments in Established and Emerging Markets, in Alleman, B.C., and Leeson, A., chairs, *In Situ and On-Site Bioremediation Symposium*, v. 4, p. 307-314, Battelle Press, Columbus, OH.
- Gohil, S., 1998, Personal communication, August 2, 1998.
- Harding Lawson Associates, 1998, In-situ bioremediation of chlorinated solvents HRC Pilot-Scale Test Results, Status: May 12, 1998: Internal Harding Lawsons Status Report.

- 
- Hashsham, S.A., Freedman, D.L., 1997, Enhanced Biotransformation of Carbon Tetrachloride by An Anaerobic Enrichment Culture, in Alleman, B.C., and Leeson, A., chairs, In Situ and On-Site Bioremediation Symposium, v. 4, p. 465-470. Battelle Press, Columbus, OH.
- Harkness, M.R., Brennan, M.J., Bracco, A.A., 1998, Stimulation of complete reductive dechlorination of TCE in Strother Soil: Microcosm and column studies: General Electric Research and Development Center Technical Information Series 98CRD040, March 1998.
- Hazen, T.C., Lombard, K.H., Lombard, B.B., Enzien, V., Dougherty, J.M., Fliermans, C.B., Wear, J., Eddy-Dilek, C.A., 1997, Full scale demonstration of in situ bioremediation of chlorinated solvents in the deep subsurface using gaseous nutrient biostimulation: Progress in Microbial Ecology (Symposium Proceedings, SBM Brazilian Society for Microbiology/ICOME-International Commission on Microbial Ecology), p. 597-604.
- Honniball, J.H., Delfino, T.A., Gallinatti, J.D., 1998, Removing recalcitrant volatile organic compounds using disaccharide and yeast extract, in Wickramanayake, G., and Hinchee, R., eds., Remediation of Chlorinated and Recalcitrant Compounds, Vol. 5, Bioremediation and Phytoremediation, Battelle Press, Columbus Ohio, p. 103-108.
- Hopkins, G.D., Semprini, L., McCarty, P.L., 1993, Microcosm and in situ field studies of enhanced Biotransformation of trichloroethylene by phenol-utilizing microorganisms: Appl. Environ. Microbiol. 59: 2277-2285.
- Hopkins, G.D., McCarty, P.L., 1995, Field evaluation of in situ aerobic cometabolism of trichloroethylene and three dichloroethylene isomers using phenol and toluene as the primary substrates: Environ. Sci. Technol., v. 29, p. 1628-1637.
- Interstate Technology and Regulatory Cooperation Work Group and Colorado Center for Environmental Management, 1996, Case Studies of Regulatory Acceptance of ISB Technologies.
- Interstate Technology and Regulatory Cooperation Work Group, 1997, An Analysis of State Regulatory and Policy Issues Regarding the Implementation of In Situ Bioremediation of Chlorinated Solvents; ITRC Regulatory Survey, Unpublished Report.
- Jenal-Wanner, U., and McCarty, P.L., 1997, Development and evaluation of semi-continuous slurry microcosms to simulate in situ biodegradation of trichloroethylene in contaminated aquifers: Environ. Sci. Technol., v.31, p. 2915-2922.
- Jerger, D., Skeen, R., Semprini, L., Leigh, D.P., Granade, S., Margrave, T., 1998, Design of in situ bioremediation system to treat groundwater contaminated by chlorinated solvents in Wickramanayake, G., and Hinchee, R., eds., Remediation of Chlorinated and Recalcitrant Compounds, Vol. 6, Designing and Applying Treatment Technologies, Battelle Press, Columbus Ohio, p. 27-32.
- Jin et al., 1995, Partitioning tracer test for detection, estimation, and remediation performance assessment of subsurface nonaqueous phase liquids.: Water Resources Research, Vol. 31, No. 5, p. 1201-1211.
- Koenigsberg, S., Farone, W., Dooley, M., 1998, A novel slow release hydrogen compound for the enhanced natural attenuation of chlorinated hydrocarbons, The First International Conference on Remediation of Chlorinated and Recalcitrant Compounds, Platform Abstracts, The First International Conference on Remediation of Chlorinated and Recalcitrant Compounds, Platform Abstracts, B2. Cometabolic Processes.
- LaPat-Polasko, L., Lazarr, N.C., Wallace, G., Tool, A.R., Drinkwine, A., 1998, Gaseous nutrient injection for TCE cometabolism at a former ammunition depot, in Wickramanayake, G., and Hinchee, R., eds., Remediation of Chlorinated and Recalcitrant Compounds, B82.

- 
- Lederer, W.H., 1995, *Regulatory Chemicals of Health and Environmental Concern*: Van Nostrand Reinhold, New York.
- Lee, M.D., Odum, J.M., Buchanan, B.J., 1998, New perspectives on microbial dehalogenation of chlorinated solvents: Insights from the field: *Annu. Rev. Microbiol.*, v.52, p.423-452.
- Legrand, R., Morecraft, A.J., Harju, J.A., Hayes, T.D., Hazen, T.C., 1998, Field application of in situ methanotrophic treatment for TCE remediation, in G.B., Hinchee, R.E., eds., *Bioremediation and Phytoremediation - Chlorinated and Recalcitrant Compounds*, Battelle Press, Columbus Ohio, p. 193-204.
- Lessage, S.S., Brown, S., Millar, K., 1996, Vitamin B12 Catalyzed Dechlorination of Perchloroethylene Present as Residual DNAPL: *Groundwater Monitoring and Remediation*, v. 16, no. 4, P. 76-85.
- Lewis, R.F., Dooley, M.A., Johnson, J.C., Murray, W.A., 1998, Sequential anaerobic/aerobic biodegradation of chlorinated solvents: Pilot-scale field demonstration, in Wickramanayake, G., and Hinchee, R., eds., *Remediation of Chlorinated and Recalcitrant Compounds*, Vol. 6, *Designing and Applying Treatment Technologies*, Battelle Press, Columbus Ohio, p. 1-5.
- Litherland, Susan, Anderson, D.W., 1997, Full-scale bioremediation at a chlorinated solvents site, in Alleman, B. and Leason, A., eds., *The Fourth International In Situ and On Site Bioremediation Symposium*, v. 5, p. 425-430.
- Mahaffey, W.R., Compeau, G., Nelson, M., Kinsella, 1992, *Journal of Water Environ. Technology*, v.4, p.48.
- Major, D.W., and E.E. Cox, 1992, Field and laboratory evidence of in situ Biotransformation of chlorinated ethenes at two distinct sites: Implications for bioremediation: *In Situ Bioremediation Symposium, Niagara -on-the-Lake, Canada*, p. 48-56.
- Malusis, M.A., Adams, D., Reardon, K., Shackelford, C.D., Mosteller, D.C., Bourquin, A.W., 1997, microbial transport in a pilot-scale biological treatment zone, in Alleman, B.C., and Leason, A., chairs, *In Situ and On-Site Bioremediation Symposium*, v. 4, p. 559-572. Battelle Press, Columbus, OH.
- Maymo-Gatell, X., Tandoi, V., Gossett, J.M., and Zinder, S.H., 1995, Characterization of an H<sub>2</sub> utilizing enrichment culture that reductively dechlorinates tetrachloroethene to vinyl chloride and ethene in the absence of methanogenesis and acetogenesis: *Applied and Environmental Microbiology*, v.61, p.3928-3933.
- Maymo-Gatell, X, Gossett, J.M., Zinder, S.H., 1997, A Dehalococcus ethenes strain 195: ethene production from halogenated aliphatics, in Alleman, B.C., and Leason, A., eds., *In Situ and On-Site Bioremediation: Volume 3*, p.
- McCarty, P.L., 1994, Ground-water treatment for chlorinated solvents, in Norris, R.D., et al., *Handbook of Bioremediation*: CRC Press.
- McCarty, P.L., Semprini, L., Robert, P.V., Hokins, G., 1990, biostimulation of methanotrophic bacteria to transform halogenated alkenes for aquifer restoration, in *In situ Bioremediation of Groundwater and Contaminated Soils*, WPCF Annual Conf., Washington, D.C., p. 80-96.
- McCarty, P.L., Semprini, L., Dolan, M.E., et al., 1991, In situ methanotrophic bioremediation for contaminated groundwter at St. Joseph, Michigan in Hinchee, R. and Offenbuttel, R., eds., *On-site Bioremediation: Processes for Xenobiotic and Hydrocarbon Treatment*, Butterworth-Heinemann, Stoneham, Mass., p. 16-40.
- McCarty, P.L., Goltz, L. N., Hopkins, G., Dolan, M. E., Allan, J., Kawakami, B.T., and Carrothers, T.J., 1998, Full-Scale Evaluation of In Situ Cometabolic Degradation of Trichloroethylene

- in Groundwater through Toluene Injection, *Environmental Science & Technology*; v. 32, p. 88-100.
- McDonald, M.G., Hargaugh, A.W., 1988, A modular three-dimensional finite-difference groundwater flow model: U.S.G.S. Techniques of water resources Investigations, TWI 6-AI.
- Molz, F.J., Boman, G.K., Young, S.C., Waldrop, W.R., 1994, Borehole flowmeters: Field Application and Data Analysis, *J. Hydrology*, v. 163, p. 347-371.
- Morse, J. J., Alleman, B.C., Gossett, J.M., Zindler, S.H., Fennell, D.E., Sewell, G., Vogel, C.M., 1998, Draft Technical Protocol - A Treatability Test for Evaluating the Potential Applicability of the Reductive Anaerobic Biological In Situ Treatment Technology (RABITT) to Remediate Chloroethenes: Department of Defense Environmental Security Technology Certification Program, p. 84.
- Munakata-Marr, J., McCarty, P.L., Shields, M., Reagin, M., Francesconi, S., 1998, Enhancement of Trichloroethylene Degradation in Aquifer Microcosms Bioaugmented with Wild Type and Genetically Altered Burkholderia (*Pseudomonas*) cepacia G4 and PR1: *Environmental Science and Technology*, v. 30, p. 2045-2052.
- National Research Council, 1997, *Innovations in Groundwater and Soil Cleanup: from Concept to Commercialization*: National Academy Press, Washington, D.C.
- Nelson, M.J.K., Montgomery, S., and Prichard, P., 1988, Trichloroethylene metabolism by microorganisms that degrade aromatic compounds: *Applied and Environmental Microbiology*, v. 54, p. 604-606.
- Newell, C.J., Hughes, J.B., Fisher, R.T., Haas, P.E., 1998, Subsurface hydrogen addition for the in situ bioremediation of chlorinated solvents, in Wickramanayake, G., and Hinchee, R., eds., *Remediation of Chlorinated and Recalcitrant Compounds, Vol. 6, Designing and Applying Treatment Technologies*, Battelle Press, Columbus Ohio, p. 47-52.
- Nielson, R.B., Kiesling, J.D., 1998, Anaerobic degradation of PCE and TCE DNAPLs by groundwater microorganisms, in Wickramanayake, G., and Hinchee, R., eds., *Remediation of Chlorinated and Recalcitrant Compounds, Vol. 4, Bioremediation and Phytoremediation*, Battelle Press, Columbus Ohio, p. 97-102.
- Nyer, E. Lenzo, F., Burdick, J., 1998, In Situ Reactive Zones: Dehalogenation of Chlorinated Hydrocarbons: *Groundwater Monitoring and Remediation*, v. 18, no. 2, p. 68-72.
- Pankow, J.F., and Cherry, J.A., 1996, *Dense Chlorinated Solvents and other DNAPLs in Groundwater*: Waterloo Press; Portland, Oregon, p. 522.
- Pardieck, D.L., Carmichael, L.M., Lutz, E.J., 1997, Site characterization of Dover Air Force Base, in Alleman, B.C., and Leeson, A., chairs, *In Situ and On-Site Bioremediation Symposium*, v. 4, p.279. Batelle Press, Columbus, OH.
- Pon, G., Semprini, L., 1997, An anaerobic-aerobic microcosm study of PCE and TCE degradation by microbes stimulated from a contaminated site, in Alleman, B.C., and Leeson, A., chairs, *In Situ and On-Site Bioremediation Symposium*, v.3, p.247-252; Batelle Press, Columbus, OH.
- Reisman, D.J., Claxton, L.D., Harvey, J.E., 1998, Bioremediation Risk Assessment: Merging Human Health and Ecological Methods, p. 3-58, in Sikdar, S.K., Irvine, R.I., eds., *Bioremediation: Principles and Practices, Volume III Bioremediation Technologies*, Technomic Publishing Co., inc. Lancaster, UK.
- Remedial Technologies Development Forum, 1997a, 100 Percent Pilot System Design of Accelerated In Situ Anaerobic Bioremediation at Dover Air Force Base: DERS Project No. 3188, p.10.



- 
- Remedial Technologies Development Forum, 1997b, Natural Attenuation of Chlorinated Solvents in Groundwater - Principles and Practices, p.42.
- Remedial Technologies Development Forum, 1998, Natural Attenuation of Chlorinated Solvents in Groundwater Training Course Workbook. Prepared by the Industrial Members of the RTDF Bioremediation Consortium in cooperation with the ITRC Work Group. Accompanies the RTDF-ITRC Training Course.
- Rice, D.W., Grose, R.D., Michaelsen, J.C., Dooher, B.P., MacQueen, D. H., Cullen, S.J., Kastenber, W.E., Everett, L. G., and Marino, M. A., 1995, California leaking underground fuel tank (LUFT) historical case analyses: Environmental Restoration Division, Lawrence Berkeley Laboratories, UCRL-AR-122207, variously paginated.
- Roberts, P.V., Semprini, L., Hopkins, G.D., Grbic-Galic, D., McCarty, P.L., Reinhard, M., 1990, In situ aquifer restoration of chlorinated aliphatics by methanotrophic bacteria: USEPA Center for Environmental Research Information, Cincinnati, EPA/6000/2-89/033, p. 33.
- Scanke, C.A., Betterman, A.D., Graham, L., Rehm, B.W., 1997, Biological treatability studies for remediation of TCE-contaminated groundwater, in Alleman, B.C., and Leeson, A., chairs, In Situ and On-Site Bioremediation Symposium, v. 3, p.267-278. Battelle Press, Columbus, OH.
- Semprini, L., P.V. Roberts, G.D. Hopkins and P.L. McCarty. 1990 A field evaluation of in situ biodegradation of chlorinated ethenes: Part 2, results of biostimulation and Biotransformation experiments. Groundwater. 28: 715-727.
- Sewell, G., DeFlaun, M.F., Baek, N.H., Lutz, E., Weesner, B., Mahaffey, B., 1998, Performance evaluation of an in situ anaerobic bioremediation system for chlorinated solvents, in Wickramanayake, G., and Hinchee, R., eds. Remediation of Chlorinated and Recalcitrant Compounds, Vol. 6, Designing and Applying Treatment Technologies, Battelle Press, Columbus Ohio, p. 15-20.
- Shields, M.S., and Reagin, M.J., 1992, Selection of a *Pseudomonas cepacia* strain constitutive for the degradation of trichloroethylene: Appl. Environ. Microbiol., v. 58, p. 3977-3963.
- Spuij, F., Alphenaar, A., de Wit, H., Lubbers, R., van de Brink, K., Gerritze, J., Gottschal, J., Houtman, S., 1997, Full-scale application of in situ bioremediation of PCE-contaminated soil, in The Fourth International In Situ and On Site Bioremediation Symposium, v. 5, p. 431-433, Battelle Press.
- Stephan, R.J., Sperry, K., Condee, W., Walsh, M. Guarini, W., Thomas, A., 1988, In situ remediation of trichloroethylene (TCE) - contaminated groundwater by bioaugmentation: The First International Conference on Remediation of Chlorinated and Recalcitrant Compounds, Platform Abstracts, E8. Bioaugmentation and Biomonitoring.
- Tovanobootr, A., Russel, S., Stoffers, N.H., Arp, D., Semprini, L., 1997, An evaluation of five aerobic cometabolic substrates for trichloroethylene treatment by microbes stimulated from the subsurface of McClellan Air Force Base, in The Fourth International In Situ and On Site Bioremediation Symposium, v. 3, p. 93-99.
- Verhagen, I.J., Wetzstein, D.W., Bruner, D.R., Hudak, C.M., 1998, Enhancing dissolved oxygen to remediate vinyl chloride in groundwater, in Wickramanayake, G., and Hinchee, R., eds. Remediation of Chlorinated and Recalcitrant Compounds, Vol. 5, Bioremediation and Phytoremediation, Battelle Press, Columbus Ohio, p. 27-32.
- U.S. Air Force Center for Environmental Excellence (AFCEE), 1998, Aerobic Cometabolic In Situ Bioremediation Technology Guidance Manual Prepared for Air Force Research Laboratory

- 
- (AFRL) Air Base And Environmental Technology Division, Tyndall Air Force Base, Florida:  
U.S. Air Force Center for Environmental Excellence Installation Restoration Program, p. 82.
- U.S. Environmental Protection Agency, 1989, EPA Guide for conducting Treatability Studies Under CERCLA, 1989 (EPA/540/2-89-059).
- U.S. Environmental Protection Agency, 1989, EPA Guidance for conducting Remedial Investigation and Feasibility Studies under CERCLA, 1989, (EPA/540/6-89/004).
- U.S. Environmental Protection Agency, 1985, Practical Guide for Groundwater Sampling: (EPA/600/2-85/104).
- United States Environmental Protection Agency, 1991a, Understanding Bioremediation, page 4, A Guidebook for Citizens, Feb EPA/540/2-91/002.
- U.S. Environmental Protection Agency, 1991b, Compendium of ERT Groundwater Sampling Procedures, 1991 (EPA/540/P-91/007).
- Verhagen, I.J., Wetzstein, D.W., Bruner, D.R., Hudak, C.M., 1998, Enhancing dissolved oxygen to remediate vinyl chloride in groundwater, in Wickramanayake, G. and G.B., Hinchee, R.E., eds., Bioremediation and Phytoremediation - Chlorinated and Recalcitrant Compounds, Battelle Press, Columbus Ohio, p. 27-32.
- Wackett, L.P., Brusseau, G.A., Householder, S.R., Hanson, R.S., 1989, Appl. Environ. Microbiol., v. 49, p. 242-243.
- Wackett, L.P. and D.T. Gibson. 1988. Degradation of trichloroethylene by toluene dioxygenase in whole-cell studies with *Pseudomonas putida* F1. Appl. Environ. Microbiol. 54: 1703-1708.
- Weesner, B., Acree, S., McAlary, T., Salvo, J.J., 1998, Design and operation of a horizontal well in situ bioremediation system, in The First International Conference on Remediation of Chlorinated and Recalcitrant Compounds, Platform Abstracts, B2-B26. Cometary Processes.
- Wiedemeier, T. H., Swanson, M.A., Moutoux, D.E., Wilson, J. T., Kampbell, D. H., Hansen, J. E., and Haas, P., 1996 Overview of technical protocol for natural attenuation of chlorinated aliphatic hydrocarbons in groundwater under development for the U. S. Air Force Center For Environmental Excellence: Symposium on Natural Attenuation of Chlorinated Organics in Groundwater, Dallas, September 11-13, 1996, EPA/540/R-96/509.
- Wilson, J.T., and Wilson, B.H., 1985, Biotransformation of trichloroethylene in soil: Appl. Environ. Microbiol., v. 49, p. 242-243.
- Workman, D., Woods, S., Gorby, Y., 1997, Microbial reduction of vitamin B<sub>12</sub> by *Shewanella* alga strain BrY with subsequent transformation of chlorinated methanes in Alleman p. 47.
- Yang, Y., McCarty, P.L., in press, competition for Hydrogen within a Chlorinated Solvent Dehalogenating Anaerobic Mixed Culture: Environmental Science and Technology, v.32.

## **APPENDIX A**

### **ITRC IN SITU BIOREMEDIATION WORK TEAM ROSTER/CONTACTS**

**ITRC IN SITU BIOREMEDIATION  
WORK TEAM CONTACTS**

**Paul Hadley**

*(Team Leader)*

Hazardous Substance Engineer  
California EPA - Dept. of Toxic Substance Control  
Office of Pollution Prevention and Technology Development  
301 Capitol Mall, 1<sup>st</sup> Floor  
Sacramento, CA 95814

P: (916) 324-3823  
F: (916) 327-4494  
E: [phadley@dtsc.ca.gov](mailto:phadley@dtsc.ca.gov)

**Bal Lee**

Senior Engineer  
California EPA  
Dept. of Toxic Substance Control  
301 Capitol Mall, 4<sup>th</sup> Floor  
Sacramento, CA 95814

P: (916) 322-8036  
F: (785) 323-3700  
E: [blee1@dtsc.ca.gov](mailto:blee1@dtsc.ca.gov)

**Brent Westfall**

Coleman Federal  
2995 N. Cole Rd., Suite 260  
Boise, ID 83704

P: (208) 375-2468  
F: (208) 375-5506  
E: [westfall@uswest.net](mailto:westfall@uswest.net)

**Randy Farr**

*(EISB Document Subgroup Leader)*

Environmental Geologist  
Kansas Dept. of Health & Environment  
Forbes Field, Bld. 740  
Topeka, KS 66620

P: (785) 296-6378  
F: (785) 296-4823  
E: [rfarr@kdhe.state.ks.us](mailto:rfarr@kdhe.state.ks.us)

**Steve Hill**

Coleman Federal  
2995 N. Cole Rd., Suite 260  
Boise, ID 83704

P: (208) 375-9029  
F: (208) 375-5506  
E: [srhill@uswest.net](mailto:srhill@uswest.net)

# **APPENDIX B**

## **ACRONYMS**

## ACRONYMS:

AFB	- Air Force Base
AFCEE	- Air Force Center for Environmental Excellence
AFIT	- Air Force Institute of Technology
AOC	- Area of Contamination
ASTM	- American Society for Testing Materials
BTEX	- benzene, toluene, ethylbenzene, xylene
cDCE	- cis dichloroethylene
CAMU	- Corrective Action Management Unit
CA	- chloroethane
CERCLA	- Comprehensive Environmental Response, Compensation, and Liability Act
CF	- chloroform
CFR	- Code of Federal Regulations
CT	- carbon tetrachloride
DCE	- dichloroethylene
DNAPL	- dense non-aqueous phase liquid
ECD	- electron capture detector
EISB	- enhanced in situ bioremediation
ESTCP	- Environmental Security Technology Certification Program
FID	- flame ionization detector
GC	- gas chromatography
HRC	- hydrogen release compound
HPLC	- high-performance liquid chromatography
ISB	- in situ bioremediation
LDR	- land disposal restrictions
MTR	- minimum technology requirements
MTT	- methanotrophic treatment technology
MPN	- most probable number
ORP	- oxygen reduction potential
PCE	- tetrachloroethylene
RABITT	- Reductive Anaerobic Biological In Situ Treatment Technology
RCRA	- Resource Conservation and Recovery Act
RGD	- reduction gas detector
RTDF	- Remediation Technologies Development Forum
SCFM	- standard cubic feet per minute
TC	- toxicity characteristics
TCA	- trichloroethane
TCE	- tetrachloroethylene
TEP	- triethylphosphate
UIC	- underground injection control
VC	- vinyl chloride

## **APPENDIX C**

### **SIX STATES REGULATORY SURVEY FOR *IN SITU* BIOREMEDIATION TECHNOLOGIES FROM 1997**

**Initial Six States Review Table, 1997**

	<b>California</b>	<b>Kansas</b>	<b>New Jersey</b>	<b>New Mexico</b>	<b>Oregon</b>	<b>Texas</b>
State programs providing general oversight	Department of Toxic Substances Control Office of Pollution Prevention and Technology Development	Kansas Department of Health and Environment Bureau of Environmental Remediation (For non-RCRA sites)  Bureau of Waste Management (For RCRA sites)	New Jersey Department of Environmental Protection Site Remediation Program	New Mexico Environment Department Ground Water Quality Bureau (For Non-RCRA)  Hazardous and Radioactive Materials Bureau (For RCRA)	Oregon Department of Environmental Quality Waste Management and Cleanup Division Site Response Section	Texas Natural Resource Conservation Commission Office of Waste Pollution Cleanup Division
State programs determining RCRA hazardous waste requirements	Department of Toxic Substance Control and Hazardous Waste Management Program	Bureau of Waste Management	Bureau of Waste Classification	Hazardous and Radioactive Materials Bureau	Waste Management and Cleanup Response Division - RCRA Section	Industrial Hazardous Waste Division
State program responsible for air emissions enforcement	State Air Resources Board??	Bureau of Air and Radiation	Division of Air Quality	New Mexico Environment Department - Air Pollution Control Bureau	Department of Environmental Quality - Air Quality Program	TNRCC
State programs responsible for Underground Injection Control (UIC) requirements	Does not have UIC Primacy	Bureau of Water	Site Remediation Branch	Water Quality Office	Water Quality Division <i>(Cleanup Division can waive water quality requirements for remediation activities)</i>	Industrial Hazardous Waste Division
State has voluntary cleanup programs:	Yes	Yes	Yes	Yes	Yes	Yes
State provides oversight for Federal Facilities	Yes	Yes	Yes	Yes	Yes	Yes
State has RCRA Corrective Action primacy	Yes	No	Yes	No	Yes	Yes
State has UIC Primacy	No	Yes	Yes	Yes	Yes	Yes

C-1



**Initial Six States Review Table, 1997**

	<b>California</b>	<b>Kansas</b>	<b>New Jersey</b>	<b>New Mexico</b>	<b>Oregon</b>	<b>Texas</b>
<b>Accelerated Anaerobic Biodegradation Pilot</b>						
State has experience with similar projects	Yes	Microbial augmentation pilot	Yes	No	Yes	Yes
State would consider the groundwater "contaminated media" under RCRA		Would depend on concentrations, type of site.		Would depend on site specific situations.	Yes	Probably
State has exemptions for RCRA and UIC Permits		No	Yes (Substantial requirements must be met)	RCRA - No UIC - Yes (substantial requirements must be met)	Yes (Substantial requirements must be met)	Yes (Substantial requirements must be met)
State allows reinjection of contaminated groundwater		Has prohibition of injection of hazardous waste above or into drinking water supply Could be interpreted to not allow injection of contaminated groundwater	Yes	As long as injection falls within Water Quality Control Commission requirements	As per earlier comment (UIC) Cleanup Division can waive water quality requirements for remediation activities	Yes
Type of UIC permit required		Class V (most likely) or IV		Water Quality Control Commission permit	Cleanup Permit	Class V
<b>Cometabolic Bioventing Pilot</b>						
State has experience with similar projects	Yes	Yes		Yes		Yes
Air Emission standards would apply	Depends on the emission levels and specific Air District involvement.	Only if >50lbs/day for most of state, less in Kansas City area		Yes		

C-2

**APPENDIX D**  
**CASE STUDY RESPONSE**

**Note to the Reader:**

The following descriptions include brief backgrounds of five sites in which EISB chlorinated solvent projects were conducted, followed by questions and answers concerning the major regulatory and technical requirements for the projects. The data was collected by written communication and conference calls during August and September, 1998.

It should be noted that questions varied somewhat from site to site. Case Studies 1-3 are primarily written responses to a standard set of survey questions. Case Studies 4 and 5 represent the responses from two conference calls in which there were a panel of representatives from either the facility or overseeing regulatory agency.

Case Study Survey Questions - (for Case Studies 1-3)

1. What is the lead regulatory agency and bureau or program?
2. What other agencies provided oversight of the remediation? (i.e. state remediation program, state voluntary cleanup program, federal CERCLA or RCRA program, etc.)
3. What was the level of oversight for each agency? (i.e. did they have complete approval authority?)
4. What types of documentation did they require from initiation to finish?
  - Scope of work?
  - Sampling and analysis plan?
  - Health and safety plan?
  - Quality assurance / Quality control plan?
  - Monitoring Reports?
  - Removal or remedial design documents?
  - Remedial or removal action documents?
  - Construction specification of injection and extraction wells?
  - Pump tests or other aquifer tests?
  - Hydrologic Modeling?
  - Engineering plans?
5. If a voluntary cleanup program, describe the regulatory oversight process.
6. Was groundwater recirculated and reinjected in your project?
  - 6a. If so, did you have to either obtain an Underground Injection Control (UIC) permit?  
Or did you have to meet UIC requirements?
  - 6b. What was the name of the agency that dealt with the UIC issue?
  - 6c. What was the name of the person that handled the permit or requirements?
  - 6d. What class of UIC permit or requirements were required? (if applicable; i.e. Class V versus Class IV well permits)
  - 6e. What type of written material was required to be provided to the UIC agency?  
(if applicable)
    - Work plan?
    - Monitoring plan?
    - Proof of containment?
    - Design plan?
    - Health and Safety Plan?
    - QA/QC plan?
    - Others?
7. Did RCRA hazardous waste regulations apply in the project?

- 7a. Did RCRA hazardous waste regulations apply in the project?
- 7b. What agency was responsible for determining RCRA requirements?
- 7c. If state RCRA program, does the state have Corrective Action Authority?
- 7d. Was the Regional EPA RCRA office involved?
- 7e. What triggered the RCRA hazardous waste issues?
- 7f. Did active management of hazardous waste (54FR36597, 40 CFR 261) apply?  
Why or why not?
- 7g. Were there specific waivers, variance, alternative treatment standards, or other similar regulatory mechanisms employed to allow the project to go forward?
8. Were any RCRA permits required (other than UIC)?
9. Were there specific investigation-derived waste disposal requirements?
10. Were there air quality regulators involved in the project?
- 10a. What types of air quality regulations applied?
- 10b. Were there permit requirements?
- 10c. Were there air monitoring requirements?
11. How much time is anticipated to be required for obtaining the various permits?
12. What were the monitoring requirements for the pilot?
- Monitoring well specifications?
  - Number and placement of wells?
  - Monitoring frequency?
  - Sampling method, approved analytical method?
  - Others?
13. What were the major elements of the pre-pilot site characterization?
- Assessment of effect of biological addition?
  - Soil permeability tests?
  - Microcosm studies?
  - Tracer tests?
  - Groundwater analysis of – VOCs, Metals, Natural Attenuation parameters?
  - Pump tests?
  - Others?
14. What is the estimated time frame for implementation? Would there be specific limitations on the allowed duration of the projects?

15. What kind of information did you provide to regulators to establish the validity of the technology?

Refereed journal publications?

•Validated testing data?

•Previous demonstration and verification reports?

•Others?

16. Was there any involvement/input from stakeholders?, If so explain.

## Case Study 1: Dover AFB Site

Contact: Eric Trinkle  
Delaware Department of Natural Resources  
Dover, DE

---

### Background:

This site covers a vast area and has multiple groundwater plumes. Currently, there are three innovative pilot studies being conducted by the Remedial Technologies Development Forum (RTDF) within the Base perimeter. The majority of contamination is derived from the previous utilization of cleaning agents which contained PCE and/or TCE. The use of these agents has since be altered and remediation efforts are currently in effect.

The ultimate goal for this system is to reduce contaminant levels in high concentration portions of the plume near DNAPL source areas. The system includes three extraction-injection cells approximately 60 feet long and 20 feet wide. The contaminated aquifer is a sandy alluvial aquifer with a hydraulic conductivity of approximately 0.021 cm/s and flow of about 1 ft/day. TCE concentrations ranged from 5 to 10 ppm, while DCE ranged from 1 to 2 ppm (Table 4). In the initial phase of study, contaminated groundwater was pumped from the three downgradient extraction wells at a rate of approximately 1.2 gpm and reinjected into the upgradient wells at the same rate. Lactic acid or sodium lactate, as well as nutrients (phosphate and ammonium nitrate) were added at intervals of 2.75 to 3.75 days. In a later phase, a natural bacterial culture from Pinellas, Florida was used to stimulate anaerobic reduction to ethene.

---

### Questions & Answers:

1. What is the lead regulatory agency and bureau or program?

**EPA Region III Superfund**

2. What other agencies provided oversight of the remediation? (i.e. state remediation program, state voluntary cleanup program, federal CERCLA or RCRA program, etc.)

**State CERCLA and RCRA**

3. What was the level of oversight for each agency? (i.e. did they have complete approval authority?)

**EPA CERCLA had complete authority, but with state input/comment**

4. What types of documentation did they require from initiation to finish?

**Scope of Work**

**Sampling and Analysis Plan**

**Health and Safety Plan**

**QA/QC Plan**

**Monitoring Reports**

**Removal or Remedial Design Document**

**Construction Specification of Injection and Extraction Wells**

**Pump Tests or Other Aquifer Tests**

**Hydrologic Modeling**

**Engineering Plans**

6. Was groundwater recirculated and reinjected in your project?

Yes

6a. If so, did you have to either obtain an Underground Injection Control (UIC) permit? Or did you have to meet UIC requirements?

**Permission was granted for a Class V well permit, with the understanding that “things were in good hands” under EPA Superfund oversight in relation to this innovative study.**

6b. What was the name of the agency that dealt with the UIC issue?

**Delaware DNREC**

6c. What was the name of the person that handled the permit or requirements?

**Bruce Patrick**

6d. What class of UIC permit or requirements were required? (if applicable; i.e. Class V versus Class IV)

**Not applicable**

6e. What type of written material was required to be provided to the UIC agency? (if applicable)

**Work Plan**

**Monitoring Plan**

7. Did RCRA hazardous waste regulations apply in project?

7a. Did RCRA hazardous waste regulations apply in the project?

**Yes, extracted groundwater with contaminants above acceptable levels is considered to be hazardous waste. If water is to be disposed (as opposed to recirculation) it would have to be disposed of at a hazardous waste landfill. However, if it were “non-hazardous” it is drained to a POTW.**

7b. What agency was responsible for determining RCRA requirements?

**The State (DE DNREC)**

7c. If state RCRA program, does the state have Corrective Action Authority?

**EPA has the lead on RCRA Corrective Action in Delaware. RCRA permitted facilities are under the State. What should be clarified is, Corrective Action as a RCRA or Superfund process vs. Groundwater corrective action performed as part of the RCRA permit process under 40 CFR 264.100. The permitted RCRA surface impoundment at the Base is under 264.100, with the State at the lead. The 3 pilots are being considered as remedies for the Base-wide Superfund program(i.e. Superfund Corrective Action). However, one or more of these remedies may also ultimately be approved as the remedial alternative for the permitted RCRA unit as part of the long term groundwater corrective action requirements set forth under 264.100.**

7d. Was the Regional EPA RCRA office involved?



**Marginally. The state kept EPA informed.**

7e. What triggered the RCRA hazardous waste issue?

**Pilot test(s) ultimately will address long term RCRA corrective action.**

7f. Did active management of hazardous waste (54FR36597, 40 CFR 261) apply?  
Why or why not?

**Yes, disposal of hazardous waste required. However, State RCRA and EPA CERCLA, as well as EPA RCRA, recognized that these pilots may represent the final remedial alternative at the Base. The consensus was that reinjection of contaminated groundwater back into the same area of groundwater contamination, for beneficial reasons, would not further assist to degrade the environment, but rather serve as a possible environmental benefit. Call it a site-specific determination. In essence, rather than subjected to hazardous waste requirements, it might be more appropriate to say “subjected to hazardous waste (and CERCLA) oversight”.**

7g. Were there specific waivers, variance, alternative treatment standards, or other similar regulatory mechanisms employed to allow the project to go forward?

**There were no alternative treatment standards for extracted groundwater meant for disposal. However, there are alternative standards which pertain to groundwater cleanup standards. These standards were addressed in the Post-closure Permit for the RCRA unit. Namely, 90% reduction in chlorinated solvent contaminant concentrations in and around the “hot spots” near the unit. This standard was adopted by Superfund for Target Areas near the RCRA unit. These Target Areas encompass the 3 pilots. However, all parties recognize that this standard is only a temporary one (i.e. an interim ROD under CERCLA; the short-term groundwater corrective action clean-up standard under RCRA 264.100) until the final Base-wide ROD is drafted. At that time, a new standard, based on all the evidence, including that garnered from the 3 pilots, will be proposed. For example, a ROD calling for intrinsic bioremediation as part of the remedy may also include source removal (i.e. by anaerobic bio.) or containment (i.e. passive barrier) coupled with down-gradient monitoring verifying no further spread of the solvent plume. This quantitative aspect (“90%”) may be dropped, or modified, if protections are shown to be in place.**

8. Were any RCRA permits required (other than UIC)?

**No**

10. Were there air quality regulators involved in the project?

**Yes**

10a. What types of air quality regulations applied?

**None, levels were insignificant**

10b. Were there permit requirements?

**None**

10c. Were there air monitoring requirements?

**Yes**

11. How much time is anticipated to be require for obtaining the various permits?

**Not applicable**

12. What were the monitoring requirements for the pilot?

**Monitoring Well Specifications**

**Number and placement of wells**

**Monitoring frequency**

**Sampling method, approved analytical method**

**Coordination of sampling required with post-closure permit and monitoring requirements for nearby RCRA unit**

13. What were the major elements of the pre-pilot site characterizations?

**Assessment of effect of biological addition**

**Soil permeability tests**

**Microcosm studies**

**Tracer tests**

**Groundwater analysis of –VOCs, Metals, Natural Attenuation parameters**

**Pump tests**

**Others(In addition, see RTDF material.)**

14. What is the estimated time frame for implementation? Would there be specific limitations on the allowed duration of the projects?

**The time estimated for implementation is 2 to 5 years. If successful, then further out.**

15. What kind of information did you provide to regulators to establish the validity of the technology?

**Referred journal publications**

**Validated testing data**

**Previous demonstration and verification reports**

16. Was there any involvement/input from stakeholders? If so explain.

**Science Advisory Board (SAB) was comprised of a wide variety of stakeholders, including the public. Regular meetings (semi-annual) are held.**

## Case Study 2: Former Manufacturing Facility - Houston, Texas

Contact: Susan Litherland  
w/ Roy F. Weston, Inc.  
Austin, Texas

---

### Background:

This site (located in Houston, TX) was used for general manufacturing purposes for many years. Based on historical records, TCE was only used for a few years in the mid-1970s. Upon the discontinued usage of TCE, the use of 1,1,1-TCE was implemented. The property was sold prior to the discovery of the solvents in the ground water. The buyers eventually declared bankruptcy for other unrelated reasons, leaving the site as a “orphan site”. The previous owners were contacted and became responsible for the remediation. Remediation was performed on a voluntary basis.

The *in situ* system uses a series of extraction and injection trenches instead of vertical wells in a full scale in situ bioremediation system. The trenches are spaced at 100 ft. to achieve desired circulation rate. The system includes 1100 linear feet of injection trenches and 1800 linear feet of extraction trenches. A rate of 12 gallons per minute has been achieved.

---

### Questions & Answers:

1. What is the lead regulatory agency and bureau or program?

**Texas Natural Resource Conservation Commission - Groundwater Enforcement Group (TNRCC-GEG) was the initial regulatory authority at this site.**

**Voluntary Cleanup Program (VCP) has assumed oversight.**

2. What other agencies provided oversight of the remediation (i.e. state remediation program, state voluntary clean-up program, federal CERCLA or RCRA program, etc.)?

**Initially, TNRCC-GEG was the only enforcement agency. However, after the project was underway a state Voluntary Cleanup Program (VCP) was instated. As a result, the overview of this project/site was transferred to the state VCP program.**

3. What was the level of oversight for each agency (i.e. did they have complete approval authority)?

**TNRCC-GEG was the primary entity which approved the treatment for the site.**

NOTE: At the time this site was approved, the TNRCC-GEG was the regulatory entity in Texas that dealt with voluntary groundwater remediation issues. Approval for such projects was coordinated with the State UIC group. Since this was a voluntary effort TNRCC-GEG focused more on the aspect of remediation, rather than the regulatory parameters/requirements.

4. What types of documents did they require from initiation of finish?

**Weston provided TNRCC-GEG with some test results (refer to #13) and pre-design characterization. In addition, Weston ensured they would conduct monitoring of the site, if the results were not favorable they would alter the remediation efforts/technology so that positive results were achieved.**

5. If a voluntary cleanup program, describe the regulatory oversight process.

**TNRCC approved the process/technology before the state voluntary cleanup program (VCP) was instated. The site has now been instated in the program (VCP). Therefore, oversight includes the review and approval of periodic status reports, which are currently issued yearly.**

6. Was groundwater recirculated and reinjected in your project?

**Yes**

6a. If so, did you have to either obtain an Underground Injection Control (UIC) permit? Or did you have to meet UIC requirements?

**Authorization from the State UIC group was obtained based on meeting the UIC requirements**

6b. What was the name of the agency that dealt with the UIC issue?

**TNRCC - Groundwater Section**

6c. What was the name of the person that handled the permit or requirements?

**Phillip Carter**

6d. What class of UIC permit or requirements were required? (If applicable; i.e. Class V versus Class IV well permit)

**No permit, just a letter of authorization**

7. Did RCRA hazardous waste regulation apply in the project?

**No permit was required because this was a non-RCRA site. Approval came from the state (TNRCC), so EPA was not involved. The intent of the remediation was to reduce the concentrations, via *in situ* technology, to risk-based levels (which are below RCRA characteristic values) NOTE: Basically, the overall focus was on obtaining remediation.**

**TNRCC was the regulatory agency involved and they wanted it remediated. They focused on the technology's ability to remediate the site. They were comfortable that adequate controls were placed on the system, which would ensure the protection of human health and the environment.**

8. Were any RCRA permits required (other than UIC)?

**Non-applicable**

9. Were there specific investigation-derived waste disposal requirements?

**No**

10. Were there air quality regulators involved in the project?

**There were no emissions associated with this technology.**

11. How much time is anticipated to be required for obtaining the various permits?

**Non-applicable**

12. What were the monitoring requirements for the pilot?

**Non-applicable, this was a full scale project.**

13. What were the major elements of the prepilot site characterization?

**Soil permeability tests, microcosm studies, groundwater analysis of -VOCs, metals, natural attenuation parameters, and pump tests were conducted.**

14. What is the estimated time frame for implementation? Would there be specific limitation on the allowed duration of the projects?

**The project was estimated to run for 3-5yrs. It start in Sept. of 1995 and should be finished within the window of Feb. -Aug. 1999. Weston is quite pleased with the results and timely manner of this technology. Concentrations have already been reduced over 95% from an average TCE concentration of 20mg/L to less than 1mg/L. Some portions of the plume have now achieved non-detect (<0.005mg/L) for TCE.**

15. What kind of information did you provide to regulators to establish the validity of the technology?

**Provided microcosm studies info., and other test results and explained that they (R. F. Weston) would conduct monitoring. If the monitoring revealed non-favorable results they would alter the process (or change technology) to obtain favorable results.**

16. Was there any involvement/input from stakeholders?

**The project was funded by a group of past property owners. Additionally, the current owner's bank and adjacent land owners have been kept informed of the progress.**

## Case Study 3 : Ark-Les - Watertown, MA

Contact: Maureen Dooley  
Harding-Lawson and Associates  
Wakefield, MA

---

### Background:

Previously, this site was utilized as a general manufacturing facility. Contaminants at this site consisted of TCE, DCE, VC, TCA, and BTEX. An initial pilot test was conducted in order to evaluate if *in situ* bioremediation was a suitable technology to reduce concentrations of the chlorinated VOCs. Favorable results were concluded from the initial test. As a result, two pilot tests were conducted using a recirculating cell system. The recirculation cell consisted of three injection and three extraction wells, designed to maintain hydraulic control. Nutrients were added to stimulate biodegradation and groundwater was pumped at 0.25 gpm.

---

### Questions & Answers:

1. What is the lead regulatory agency and bureau or program?

**Massachusetts Department of Environment Protection (MA DEP)**

2. What other agencies provided oversight of the remediation (i.e. state remediation program, state voluntary clean-up program, federal CERCLA or RCRA program, etc.)?

**No other agencies were involved with regulation (only MA DEP), however the pilot testing was initially conducted under the US EPA SITE program, so testing procedures were reviewed by EPA.**

3. What was the level of oversight for each agency (i.e. did they have complete approval authority)?

**The State ran the project as far as how the site was going to be cleaned up. EPA's involvement was in the technical realm, as far as design and sampling and analysis plans (Under SITE program).**

4. What types of documents did they require from initiation of finish?

- Scope of work? - **yes**
- Sampling and analysis? - **yes**
- Health and safety plan? - **yes**
- QA/QC plan? - **yes**
- Monitoring reports? - **yes**
- Removal or remedial design documents?
- Construction specification of injection and extraction wells? - **no**
- Pump tests or other aquifer tests? - **no**
- Hydrologic modeling? - **yes**
- Engineering plans? - **no**

5. If a voluntary cleanup program, describe the regulatory oversight process.

**This site was inducted under the PITS - Innovative Technology Testing Program. In order to be accepted into this program a meeting with MA DEP was endured, in order to discuss the technology's design and answer any relative questions.**

6. Was groundwater recirculated and reinjected in your project?

**Yes**

6a. If so, did you have to either obtain an Underground Injection Control (UIC) permit? Or did you have to meet UIC requirements?

**No, this was a pilot so a permit was not needed.**

6b. What was the name of the agency that dealt with the UIC issue?

**Non applicable**

6c. What was the name of the person that handled the permit or requirements?

**Non applicable**

6d. What class of UIC permit or requirements were required? (If applicable; i.e. Class V versus Class IV well permit)

**Non applicable**

7. Did RCRA hazardous waste regulation apply in the project?

**No**

8. Were any RCRA permits required (other than UIC)?

**No**

9. Were there specific investigation-derived waste disposal requirements?

**Any IDW from sampling (groundwater) was poured back into the extraction wells, thus staying within the system.**

10. Were there air quality regulators involved in the project?

**No**

11. How much time is anticipated to be required for obtaining the various permits?

**Six months were allotted for state review of program.**

12. What were the monitoring requirements for the pilot?

**We provided a sampling plan, which met approval of state/EPA. Involved frequent monitoring, minimum of monthly reporting. We monitored VOC levels in 3 monitoring wells and injection wells within the recirculation cell. The whole site is sampled annually. We also collected vapor samples from locations within the treatment cell to insure VC was not detected in the gas phase. The main issue was the presence of VC. If the VC exceeded a certain limit then we were required to convert the system over to an aerobic treatment system, in order to biodegrade VC.**

13. What were the major elements of the prepilot site characterization?

- Assessment of the effect by biological addition? - **yes**
- Soil permeability?
- Microcosm studies?- **yes**
- Tracer tests?- **yes**
- Groundwater analysis of - VOCs, Metals, Natural Attenuation parameters?- **yes**
- Pump tests?- **yes**
- Other(s)?

14. What is the estimated time frame for implementation? Would there be specific limitation on the allowed duration of the projects?

**We have been running for two years. The overall duration will be related to VC levels. Basically, as long as the VC levels are elevated we need to continue treatment.**

15. What kind of information did you provide to regulators to establish the validity of the technology?

**Bench scale test data was provided, along with documentation in regard to 10 years of experience with reinjection systems and associated permitting requirements. However, the most important information relayed to the regulators was the ability to contain vinyl chloride and evidence of a fail-safe/contingency plan.**



## Case Study 4 : Cape Canaveral Site

Contacts: Cathy Vogel, DoD                      Gale Onorato, TRW  
David Criswell, EnRisk                      Bruce Alleman, Battelle  
Todd Swingle, Parsons                      Jeff Morse, Battelle  
Randy Wolf, DoD

---

### **Background:**

#### Background of Facility 1381

Currently this site serves as an Armory. In the past, this facility/site served as a machine shop where TCE was utilized as a cleaning agent for various parts. As a result, a chlorinated solvent plume (TCE and daughter products) originated. The plume covers 110 acres and has a relative isolated hot spot adjacent to the facility. The nature of this plume consists of a medium to coarse grain sand in the upper 30 feet, a fine grain sand below 30 feet (thought to act as a vertical barrier), possible DNAPLs above this layer, and ground water present from 5 to 10 feet in depth.

NOTE: Presently this facility is owned by the Cape Canaveral Air Station but occupied by the Coast Guard.

#### Regulatory Authorization

This facility (1381) is under the Cape Canaveral RCRA permit (the RCRA program manager is Tim Woolheater (Atlanta)). This is a dual RCRA permit, delegated by the state of Florida and U.S. EPA Region IV. The State of Florida issues the operating RCRA permit, which regulates the active regulated RCRA TSD unit. EPA issues the HSWA, which regulates the RCRA corrective action program.

#### Project Status

At this point Battelle has written a Site Specific Work Plan rough draft (which utilizes the EPA protocol as the main attachment). However, there has not been, or will be, a finalization of this document until there is regulatory approval.

Upon regulatory approval, the Site Specific Work Plan will be finalized and include a health and safety plan, a sufficient level of design detail (for state purposes), and a QAPP.

---

### **Questions & Answers (Note that questions are different from those posed to previous case studies.)**

1. Will there be separate design documents or will it all be incorporated into the initial Work Plan (i.e. engineering design)?

**As far as the state is concerned, since this is a fairly straight forward system and in the pilot stage, there is no need for separate design documents. Even if this was a full scale system there would not be a need for separate documents because the design documents could be included in the work plan, but ‘as-builts’ would be required when done.**

2. Is ground water going to be extracted, recirculated, and/or reinjected in vertical wells?

**This is the goal, however there is some negotiation in this area (horizontal vs vertical wells) and applicability of the UIC program.**

[\* refer to “Interpretation of infiltration trenches vs wells (in Florida)”, question #8]

3. What about the scale of system?

Overall, the system is considered to be small. The cell is defined as being 30 feet long with 3 injection wells at one end (3 foot screened intervals on an 18 inch center). Monitoring includes pulling media across 3 rows of monitoring wells. There is a separate extraction well which is used to pump the contaminated water out. This extracted water is mixed with an electron donor solution and then reinjected into the injection well.

4. Does EPA agree/go along with the idea of extracting and injecting without substantial treatment?

EPA referred the Cape Canaveral and Patrick AFB Environmental Restoration Partnering Team to a guidance document, 1989, and a section of RCRA statutes which allow for the reinjection of ground water. However, EPA Region IV said they would consider "the addition of an amendment prior to reinjection as a substantial treatment". (NOTE: nothing was provided in writing by EPA other than the reference to the guidance document, 1989, and statutes). As a response to EPA's interpretation, the work team drafted a memo which proposed this topic (the addition of an amendment to the reinjected media is considered to be substantial treatment) and sent it to EPA and Cape Canaveral personnel. Currently there is approval on this issue pending a decision on compliance and applicability of the UIC program.

There is an alternative issue in relation to the FDEP UIC program, which has not provided approval for vertical injection wells. (In Florida, the EPA has deferred the UIC program to the state.) However, this program has said that if an infiltration gallery is used instead of an injection well, it would not be under the jurisdiction of their program and would not be prohibited.

5. How did you interpret RCRA 3020(b), does this say "substantially treat" or "substantial reduce the level of contaminants"?

EPA Region IV interprets this to say "that you have to treat it (the contaminant) to substantially reduce it (the contaminant)" not necessarily that you have to reduce it (the contaminant) prior to reinjection. However, you must still meet the other criteria; such as, protect human health and the environment, and the system has to be a RCRA or CERCLA corrective action.

NOTE: Exemptions of each site are left up to the EPA Project Manager (i.e. what is considered to be adequate public and environment protection, what is considered to be substantial treatment efforts)

6. Did you attempt to utilize or address the AOC, Area of Contamination issue?

This was also addressed by the Cape Canaveral Work Team. It was established that an AOC is applicable to RCRA sites. Typically this refers to soils, however, EPA (Region IV) felt this could apply to ground water as well.

The AOC at this site was defined as the source area of the plume. Under the guidance of an AOC the LDR requirements are considered to be relevant/appropriate but not required.

NOTE: an AOC is a 'policy designation' which the remedial project manager can make via a letter.

NOTE: the act of pumping the water out and returning it to a defined area of contamination, without the addition of amendments, is not considered to be active management.

7. What class of injection well does the state consider this to be, the injection of hazardous waste?

**Florida prohibits the injection of hazardous waste, therefore no Class IV wells are allowed . In this case the state would not consider this to be a Class V well for remediation if the TCE concentration levels are high enough to be listed as a “characteristic” or “listed” hazardous waste. At this site the levels would be considered hazardous waste, therefore constituting a Class IV well, which is prohibited.**

8. Are directional drilled, horizontal wells considered a well?

**This would depend. If a trench were dug and a pipe was laid horizontally in the trench, this would be considered an infiltration gallery. However, if this were a (dug) trench in which there was a header with screens coming off vertically, this would be considered a well (key word “vertical”).**

9. Does Florida have a proposed system for a petition or ‘an allowance of variance from prohibition’ to be filed?

**Because Class IV wells and the injection of hazardous waste are prohibited by statute, rather than regulation, there is no waiver available. However, if the issue was addressed by a regulation then there might be a way to receive a waiver.**

10. Didn’t EPA propose some changes to the UIC program to allow for beneficial remediation?

**This was for Class V wells. A problem arises, when a UIC person classifies a well as that other than a Class V well (as stipulated by regulations). In this situation (Facility 1381), or others, the only way to gain Class V well status is to determine that the contaminant(s) are not considered to be hazardous under the “contained in” rule.**

11. When you approach the facility, then later the state regulators, what did they require as supporting documentation (i.e. previous pilot data, proof of qualifications)?

**At first, a work summary (of laboratory results and prior site accomplishments) was presented to Cape Canaveral Air Station. However, no resumes or documents providing qualifications were needed. This was related to a couple of factors; such as, an already well established reputation, and a common acceptance from past and current projects (a proven track record).**

12. If you were put in the role of a regulator, what would you like to see proposed?

**Elements mentioned on the basis of an “innovative test for an innovative technology” are as follows:**

- **Documentation proving hydrologic control**
- **Proper monitoring and/or tracking mechanisms**
- **The focus upon control, not so much in the past experiences but rather on the present situation**
- **Site specific microcosm/lab data – backup data**
- **Knowledge of other sites where this technology or relative technologies are being deployed. If this were an innovative technology, then there should be justification provided for why this technology should be used as compared to already proven technologies.**

13. Did the Air Force look at trying to define the area under a CAMU ?

**No, they used the AOC concept.**

14. How did you get around the around the issue of conducting treatment?

**EPA did not really address this part. Once EPA recognized the statute exemption and referencing of the guidance document, 1989, they gave their approval without the need for any permits for treatment. Treatment permits are not applicable for an AOC designated site. Realistically, depending on the regulator, the AOC argument could circumvent the entire issue, except the UIC.**

NOTE: A memo, 1996, from Michael Shapiro to the regional RCRA chief reveals that AOCs can be addressed to RCRA and state cleanups.

## Case Study 5: Former Naval Ammunition Depot - Hastings, NE

**Contacts:** Allen Tool - US Army Corps of Engineers  
Arbor Drinkwine - US Army Corps of Engineers  
Mirek Towster - US Army Corps of Engineers

---

### Background:

Arbor Drinkwine – professional insight regarding the chemical aspects  
Mirek Towster – professional insight regarding the technical manager role  
Allen Tool – professional insight regarding environmental and technical aspects

This was formerly a DoD site, a Naval Ammunitions Depot (NAD). The project was directed at the remediation of a TCE plume. The plume is characterized as being 17 ft. thick with a varying width of 500-1000 ft. Areas of concern include one vertical well and one horizontal well. The vertical well is located near the source ( a manhole, believed to be a source where contaminants were dumped). The horizontal well is located down-gradient several hundred yards. This well has a 200 ft. long screened interval and is located near the bottom of the aquifer. The purpose of this well is to intercept the down-gradient movement of the plume.

Originally, remediation techniques were used, such as air sparging (AS) and soil vapor extraction (SVE). These techniques served as viable remediation processes but target levels were not obtained. Due to these results, the project was retrofitted to add the injection of methane, triethylphosphate (TEP), and nitrous oxide. The utilization of each of these amendments up to this point includes: methane and triethylphosphate have been pumped for the past 6 months, nitrous oxide was injected for a brief duration due to adequate nitrogen levels present within the aquifer.

VOC data is collected from the monitoring wells, which are located at various positions up and down-gradient. At the present time the data has depicted a reduction of contaminants. The results are primarily based on the increase of CO<sub>2</sub> and the decrease of TCE levels.

---

### Questions and Answers (Note that questions are different form those posed to previous case studies).

1. What is the lead regulatory agency, bureau and/or program?

**This is a Formerly-Used Defense Site (FUDS). The responsibility has been delegated to the Army Corp. of Engineers. The Regulatory aspects are overseen by the State of Nebraska and EPA (Region VII). An Interagency Agreement (IAG) has been drafted, but not yet signed (expected to be signed shortly, within the next few months). Currently, operations are proceeding under the “spirit of IAG”, which means that there is a draft in place and all the parties are abiding by it.**

2. What other agencies provided oversight of the remediation? (i.e. state remediation program, state voluntary cleanup program, federal CERCLA or RCRA program, etc.)?

**This is a CERCLA site. The IAG defines who has oversight. EPA, Region VII, has deferred authority to the State (of NE); so far, if the State is satisfied then EPA usually goes along with the plan/idea.**

3. What types of documentation did they require from initiation to finish?

**All parameters were covered (scope of work, sampling and analysis plan, health and safety plan, QA/QC plan, monitoring reports, removal or remedial design documents, remedial or removal action documents, construction specification or injection and extraction wells, pump tests or other aquifer test, engineering plans). However, there was no hydrologic modeling.**

NOTE: This site was different from other sites we have looked at in terms of “extraction” and “injection” wells. The “extraction” well was used for the extraction of a vapor (part of the AS system), not a liquid. The “injection” aspect included the injection of a gas or vapor with the air stream, the gas and/or vapor are not considered to be a hazardous waste or contaminated media.

4. Was there any alternative regulation instated when amendments were added to the injected air?

**No specific issues, just water monitoring for total phosphate, methane, NO<sub>2</sub> and NO<sub>3</sub>.**

5. How is the project defined in relation to “scale”?

**The project operates as a full-scale operation, but is classified as a pilot study.**

6. Since there is no injection of solutions, was there any need for a UIC permit or licensing procedures?

**No there was not. However, TEP is believed to not truly volatilize to a gas, but remain more as an aerosol, but this still did not trigger an UIC permit.**

7. How are source areas defined?

**Source areas are defined by soil gas. A soil gas reading over 100 mg/L will be classified as a source area.**

8. Were there any boundary conditions or size limitations to the treatability study, or was it pretty flexible?

**There were no limitations, the well was placed in a highly contaminated area to cut off the plume and stop it from migrating.**

9. Did you have to meet any requirements for material disposed from the SVE?

**Initially there were carbon filters and water that contained contaminated media (contained TCE). These elements had to be treated to RCRA requirements, because we knowingly created TCE and contaminated the media. However, the process was changed and the TCE is now vented openly to the atmosphere. The emissions given off are now limited (approx. 2 tons/yr).**

10. Did you have an air permit to do the venting?

**No, there was not one required, just air monitoring by PID.**

11. How many wells were required within the aquifer to monitor the injectants, could you use the existing wells or did others have to be added?

**Originally there were 26 wells, at the present there are 32 wells. There are no requirements to the number of wells, basically it is left up to the Army Corp. and how many wells we see fit to monitor and derive results from the plume. However, none of these wells are set up for long-term monitoring.**

12. Is the state accepting data from these wells that levels are being met?

**Yes. In addition, two levels of certainty are established, or at least are attempted to be met. One is the reduction of TCE and DCE, the other being the increase of biological activity, especially methanotrophs.**

13. There was an abundance of mass removed before the aspect of the project was started, so the concentrations were at what level when you started with the biological aspects in the water phase?

**The up-gradient is 1000-1500ppb (still flowing into the treatment area). The treatment area ranges from 50-200ppb after air sparging alone.**

14. How do you differentiate the biological treatment from the mass removal when you inject methane, in order to carry it (the contaminate) out of the water, because it (methane) is another volatile gas?

**This is measured by a decrease from a consistent level acquired from air sparging, the comparison of prior levels to present/received levels. Basically, we look at the TCE/DCE concentration, along with the increase in methanotrophs and/or increase in CO<sub>2</sub> production.**

15. Has the State of Nebraska and EPA agreed that if you demonstrate success through this treatability study that you will be able to use this at other sites or on other plumes at this site (the NAD)?

**Not really, no real verbal agreement/commitment has been offered. However, at the same time, no real opposition has been raised. In starting out there were no feasible goals set. These (goals) have been established in relation to MCLs and successes as the project has evolved. In general, as long as the project has gone along on sound technical plans there has been little resistance.**

16. Is there going to be any scale-up issues?

**The project is pretty much full-scale, the scale issue will be based more on monetary values.**

17. What was the determination for the use of vertical and horizontal wells?

**The vertical well was put in place to hit a specific source area, an area of concentrated high contamination. The horizontal well was put in place to cut off the plume, in an area of greater width.**

18. Has there been a situation where two regulatory agencies have overseen a related aspect of the project (i.e. RCRA CA along with CERCLA ARAR)?

**No, not really. The only time RCRA was involved was when a contaminated media is shipped off-site. There is no liquid waste, so RCRA is not a primary influence in relation to this project.**

19. Was there or has there been involvement from stakeholders (i.e. public, community persons)?

**Yes. A portion of this plume is on private land, so there is communication with the owner. Also, there is a Restoration Advisory Board (RAB) which consists mostly of local persons. The RAB is allowed to purpose questions and comments about the project. Both of these avenues are pursued in regard to putting “the public concern to ease” and to improve public relations.**

20. In order to establish a target for performance in relation to the nutrient addition system, must you treat to MCLs, or are you looking for a substantial reduction across the aquifer?

**At this point, due to the large number of technologies used and the fact that many technologies are pilot scale studies, we are looking at the effectiveness. However, MCLs are not ignored and may be targeted, but are by no means the premiere value which determine success or failure for this stage/scale.**

21. How long will the system need to operate to defend these efficiencies?

**The air sparging had to operate for one year before it was turned into a removal action. The *in situ* bioremediation project is on going, so far it has operated for 6 months and will continue for another 6 months. Vapor stripping is on-going as well.**

22. Was there a risk assessment done?

**This is being done as we speak. The NAD originally had three pumping wells as a water source. Two of these wells have been shut down. To remedy this problem the people that used these (contaminated wells), have been put on bottled water.**

23. In regards to the excavated site, was the media disposed of, treated on site, or was it hauled off to a hazardous waste facility?

**It was not treated on-site, it was disposed of off-site. Tests were done to determine if the soil had to be treated. For TCE or solvent areas a headspace test was done in the field, if this value was above 50ppm then a TCLP VOA determination had to be done. If the area failed, above the 50ppm, then the media had to be disposed of as a RCRA hazardous waste. For other soils which contained explosives or metals, the same testing procedures/criteria were carried out. However, it is believed that none of these contaminants were in high enough concentration to cause excess values/failure, in relation to the test.**



**APPENDIX E**  
**REGULATORY ISSUES AND SOLUTIONS**

## **Regulatory Barriers Preventing Deployment of *In Situ* Bioremediation Technologies**

During the course of development of the *Regulatory and Technical Guidance for In Situ Bioremediation of Chlorinated Solvents in Groundwater*, our group has identified a major regulatory impediment to the deployment of particular class of *in situ* bioremediation. The critical elements of this technology include:

- The withdrawal of contaminated ground water,
- The addition of amendments to the ground water, and
- The injection of the contaminated ground water back into the contaminant plume without substantially reducing the concentration of contaminants in the injected fluid.

The withdrawal and injection results in the establishment of a recirculation cell that helps to distribute the amendments through the targeted plume and increases the residence time within the treatment zone. Once distributed within the groundwater, the amendments stimulate microbial biodegradation processes that can significantly reduce the mass of contaminants.

This type of bioremediation system triggers the following RCRA-related regulatory issues:

- Withdrawn groundwater may be considered a contaminated media under EPA's "Contained-In" Policy (40 CFR 261.33(b)).
- Withdrawal may constitute active management of hazardous waste, thus triggering land disposal restrictions (RCRA Section 3004 (f), (g), and (m)).
- Contaminated media is to be treated as hazardous waste until it no longer contains the listed hazardous waste. The Toxicity Characteristic (40 CFR 261.24 Table 1) concentrations have been used to determine the level above which groundwater is to be treated as hazardous.
- Injection of hazardous waste into a usable aquifer constitutes land disposal (RCRA Section 3004 (f), (g), and (m) and 3020(a)). Because contaminated media under the "Contained-In" Policy requires treatment as hazardous waste, LDR restrictions could apply.

RCRA attempted to address the fourth issue by specifically allowing the reinjection of treated groundwater for the purposes of remediation in the case of RCRA or CERCLA cleanups (RCRA Section 3020(b)). However, this statute has been interpreted to require substantial treatment resulting in a reduction in contaminant levels prior to reinjection. Proponents of this technology maintain that it is often not economically feasible to clean up the contaminated groundwater prior to reinjection and argue that there are no sound scientific or risk-based justifications for doing so. Furthermore, there appear to be no federal regulatory mechanisms to allow the reinjection to occur in non-RCRA or non-CERCLA sites.

We would like to obtain from the Environmental Protection Agency, some clarification on how these regulatory issues affect groundwater remediation systems that propose to withdraw and reinject contaminated groundwater. We would like the following issues addressed:

### 1.Reinjection RCRA 3020(b)

**Issue:** RCRA 3020(b) states that contaminated ground water must be treated to substantially reduce hazardous constituents prior to reinjection. It is unclear that this requires both treatment *and* a reduction of contaminant levels prior to injection, or just substantial treatment prior to injection, with the ultimate result being a reduction in contaminant levels within the aquifer.

**Solution:** Clarify this statute to allow treatment by nutrient addition or bioaugmentation that will constitute substantial treatment in situ.

### 2.Non- RCRA or non-CERCLA contaminated sites

**Issue:** If the site cleanup ( regarding groundwater and related contaminants in this situation) is not conducted under CERCLA or RCRA Corrective Action authority then it is unclear whether CERCLA or RCRA regulatory mechanisms, to allow injection (such as RCRA 3020b), would apply.

**Solution:** Clarify that state remedial and voluntary cleanup programs should have the same regulatory mechanisms to expedite cleanups as CERCLA and RCRA Corrective Action unless more restrictive state regulations supercede the federal regulations.

### 3.Area of Contamination or Corrective Action Management Unit

**Issue:** A CERCLA - AOC (Area of Contamination- 40 CFR part 300) or a RCRA - CAMU (Corrective Action Management Unit (40 CFR part 264 Subpart S) were designed to facilitate rapid and cost effective site remediation by reduced regulatory requirements as long as waste is managed (treated, stored or disposed) within the AOC or CAMU. If managed within the AOC or CAMU, Land Disposal Restrictions (LDRs) treatment standards and minimum technology requirements (MTRs) will not be triggered.

**Solution:** Clearly define that an AOC or CAMU can be defined by the areal extend of the plume thereby allowing above ground extraction and reinjection (i.e. a recirculation system) without triggering LDR and MTR requirements.

### 4.OSWER Directive 9380.0-25, 4/29/96

**Issue:** EPA is encouraging demonstration and the use of promising new technologies, including those involving injection of amendments to enhance biodegradation (OSWER Directive 9380.0-25, April 29, 96.)

**Solution:** Clarify/modify this directive to clearly include the use of amendments added to extracted ground water to enhance in situ bioremediation.

## 5. Treatability Variance

**Issue:** When an AOC or CAMU approach cannot be used for any reason, it is unclear whether it would be appropriate to use a Treatability Variance (40 CFR 268.44) to establish ultimate cleanup levels. Can a Treatability Variance be obtained to allow extracted ground water to be reinjected into the subsurface to enhance in situ biotreatment technologies.

**Solution:** Clarify that Treatability Variances can be issued to promote the use of amended ground water injected into the aquifer to accelerate *in situ* bioremediation.

## 6. Class IV UIC wells

**Issue:** Class IV UIC wells: When extracted ground water is to be treated as hazardous waste under the “Contained-In” Policy, reinjection into a useable aquifer to enhance bioremediation could be considered a Class IV injection. This injection would be prohibited for most non-CERCLA or non-RCRA sites (40CFR 144.13). This could force unnecessary treatment of amended groundwater prior to reinjection, and may result in unacceptable costs for EISB projects.

**Solution:** Provide clarification that wells being used for reinjection of amended groundwater to enhance bioremediation, may be classified as a Class V well rather than Class IV wells.

# **APPENDIX F**

## **State Class V Well Permit Example**

**CLASS V  
UNDERGROUND INJECTION CONTROL  
PERMIT APPLICATION FOR SUBSURFACE  
INJECTION OF FLUIDS IN CONJUNCTION WITH  
A GROUNDWATER REMEDIATION PROJECT**

Submit in duplicate to:

Kansas Department of  
Health & Environment  
Bureau of Water  
Environmental Geology Unit  
J. Street, 2 North  
Building 283  
Topeka, KS 66620

Date \_\_\_\_\_  
Legal Description of Well(s)  
Sec. \_\_\_\_\_, T \_\_\_\_\_ S, R \_\_\_\_\_ (E)(W) \_\_\_\_\_  
feet from South line of SE/4 of the section \_\_\_\_\_  
feet from east line of SE/4 of the section \_\_\_\_\_  
Well(s)# \_\_\_\_\_  
County \_\_\_\_\_  
Top Hole Elevation \_\_\_\_\_  
New Well(s) \_\_\_\_\_  
Well(s) Being Repermitted \_\_\_\_\_  
Permit# \_\_\_\_\_

Operator Name and Address:

\_\_\_\_\_  
\_\_\_\_\_  
\_\_\_\_\_

Contact Person Name:

\_\_\_\_\_  
Phone: \_\_\_\_\_  
\_\_\_\_\_

In conformity with K.S.A. 65-164, 65-165 and 65-171d, the undersigned representing

\_\_\_\_\_  
(name of company, corporation or person applying)

hereby makes application to the Kansas Department of Health and Environment (KDHE) for a permit to inject non-hazardous fluids into or above an underground source of fresh or usable water by means of an injection well(s) for the purpose of remediation of contamination. This application shall be signed by an executive officer of a level of at least Vice-President.

1. The applicant shall provide documentation with this application that KDHE's Bureau of Environmental Remediation has approved a remediation plan that includes the use of the proposed injection well(s). Describe the contamination problem proposed for remediation, including a discussion of the source of the contamination.
2. Describe in detail the function of the well(s) within the scope of the remediation project.
3. Describe the fluids to be injected. Include predicted concentrations of the parameters of concern in the injection fluid. Provide information for each unique injection material or additive including Material Safety Data Sheets. If materials or additives are mixed prior to injection, provide an analysis of the batch conditions. Otherwise provide an analysis for each material if materials are to be injected sequentially, or manifold mixed during injection. Additional testing of the fluid to be injected may be required after review of the application and pertinent information. All analyses shall be conducted by a laboratory certified by the State of Kansas.
4. Provide a description of the injection zone including lithology, hydrology, porosity, permeability, groundwater flow velocity, transmissivity, specific capacity and coefficient of storage. Include geologic maps, diagrams, geologic cross-sections, contamination concentration maps, a piezometric surface map, and results of aquifer pump tests. Provide references for the information submitted.

**5. Injection Zones:  
Geologic Name(s)**

**Depth to:  
Top                  Bottom**

--	--	--

**6. Well Completion**

**Borehole, casing and cement or grout information.**

Borehole Size	Casing Size	Material Size	Weight lbs/ft	Wall Thickness	Casing Seat or Gauge no.	Depth	Type Cement or Grout	Amount Cement or Grouted	Cement or Grout Interval from          to

Screen or perforation material: \_\_\_\_\_

Type of screen or perforation openings: \_\_\_\_\_

Screen or perforations intervals:

from \_\_\_\_\_ to \_\_\_\_\_ from \_\_\_\_\_ to \_\_\_\_\_

from \_\_\_\_\_ to \_\_\_\_\_ from \_\_\_\_\_ to \_\_\_\_\_

Gravel pack intervals:

from \_\_\_\_\_ to \_\_\_\_\_ from \_\_\_\_\_ to \_\_\_\_\_

from \_\_\_\_\_ to \_\_\_\_\_ from \_\_\_\_\_ to \_\_\_\_\_

To facilitate grouting, the grouted interval of the well bore shall be drilled to a minimum diameter at least three inches greater than the maximum outside diameter of the well casing. Provide information describing the seal to be used on top of the well casing. This seal shall be air and water tight. If a pitless well adapter shall be so designed and fabricated to prevent soil, subsurface or surface waters from entering the well. If the wellhead is to be completed below the finished ground level the wellhead shall be enclosed in an approved water tight vault. The top of the vault shall be sloped to allow drainage away from the vault. Provide information describing the design of the vault. Provide an explanation describing why it is necessary to complete the wellhead below ground level.

7. Provide a detailed schematic drawing indicating the proposed well(s) completion at the surface and subsurface.

**8. Fluid Injection Rate:**

Fluids are to be injected at a minimum rate of \_\_\_\_\_ gallons/day to a maximum rate of \_\_\_\_\_ gallons/day. Demonstrate by appropriate calculations the well(s) is capable of receiving the proposed maximum fluid injection rate. Provide references for sources of all values used in the calculations.

**9. Injection Pressure:**

Maximum wellhead injection pressure will be \_\_\_\_\_.

Minimum wellhead injection pressure will be \_\_\_\_\_.

Demonstrate by appropriate calculations the proposed maximum injection pressure will not fracture the injection zone or damage the well components.

**10. Discuss the stimulation program for the well(s), including chemical treatments and mechanical means.**

**11. Discuss the proposed injection procedure for the well(s) and provide a diagram. Describe the injection well pattern. Submit a design plan for the injection system including any pumps, filters, lines, and tanks used in the injection system.**

**12. Describe the meters or gauges that will be used to measure injection volume, injection rate, and injection pressure. Include the frequency of calibration.**

**13. Provide a plugging and abandonment plan for the well(s). The plugging plan must include the type of grout, estimated volume of grout, and a description of the grout emplacement procedure. Include a diagram of how the well will be plugged. Guidelines are attached.**

**14. Provide a map showing the well(s) to be permitted, surface water bodies, springs, mines, quarries, water wells, monitoring wells, withdrawal wells, any other penetrations of the aquifer and other pertinent surface features within the 1/4 mile radius area of review. The map must be clear and readable with the 1/4 mile radius area of review drawn on the map. A tabulation of data on all the wells within the area of review must be provided including the status, type, construction, date of drilling, location, depth and plugging or completion data. Key the tabulated wells to their location on the map.**

**15. Provide modeling results for the proposed injection - withdrawal scenario. The model used shall be approved by KDHE's Bureau of Environmental Remediation. Documentation of this approval shall be provided with this application. Provide a plan for monitoring the effects of injection on the groundwater system in the vicinity of the remediation project. Describe the monitoring wells to be used for this purpose. Include the data to be collected from the monitoring wells, frequency of data collection, data presentation format, and frequency of reporting the data to KDHE.**

**16. The well(s) shall be constructed by a water well contractor licensed by KDHE. Provide the contractors name, business address, and KDHE license number.**

**17. The following must be submitted to and approved by KDHE upon completion of the well(s).**

- A. A log(s) for the well(s)**
- B. KDHE water well record form WWC-5**
- C. Complete casing, cementing or grouting, and screening information. Include work reports, work tickets or other documentation.**
- D. A schematic drawing showing the actual completion of the well(s) at the surface and subsurface, if different from the proposed completion.**



**AUTHORITY**

**To whom should future correspondence be addressed:**

\_\_\_\_\_  
\_\_\_\_\_

(signed) \_\_\_\_\_

**I hereby certify that the statements herein are true and correct to the best of my knowledge and belief.**

\_\_\_\_\_  
**Signature of Applicant or Duly Authorized Agent**

\_\_\_\_\_  
**Title**

**Subscribed and sworn to before me this \_\_\_\_\_ day of \_\_\_\_\_, 19\_\_\_\_**

\_\_\_\_\_  
**Notary Public**

**My Commission Expires \_\_\_\_\_**

**6/94**

## **APPENDIX G**

### **1998 - State Underground Injection Control (UIC) Program Survey**

## State Underground Injection Control Program Survey (1998)

STATE	ALABAMA		CALIFORNIA		COLORADO	
Contact Name - Number	Scott Hues (334) 271-7759		Greg Bartow (510) 622-2315		Charles Johnson (303) 692-3348	
Question #	Yes/No	Comment	Yes/No	Comment	Yes/No	Comment
1. Does your state have an established UIC (Underground Injection Control) program? If so, what agency/division oversees this program? Is there UIC primacy?	Yes	Alabama Dept. of Environmental Management - Water Division - Groundwater Branch; have primacy	No	The only UIC well overseen by CA are Class II by the CA Div. of Oil and Gas. Class I, III, IV, and V are overseen by EPA Region IX	Yes	CO Dept. of Public Health & Environment - Water Control Division and Hazardous Waste Division; have primacy
2. Does your UIC program require hydrogeologic modeling to provide proof of containment?	Yes	Department requires the submittal of a "Hydrogeological Site Evaluation" which includes the depth to groundwater, soil characteristics, groundwater flow, presence of any water wells within a 0.5 mile radius		State follows US EPA Region IX protocols	No	Based on monitoring data and, in some situations, hydraulic containment
3. Do you allow or would you allow a Class V well to be utilized for remediation purposes (i.e. reinjection for in situ purposes)?	Yes	Issue a (5X26) Class V permit	Yes	Yes with US EPA concurrence. Individual Regional Boards in CA make site-specific decisions regarding the use of injection wells for remediation purposes.		For now, injected water can not exceed MCLs/limits, however exceptions may be made on a case-by-case basis dependent upon containment
4. Is there or could there be an allowance for injection/reinjection of amendments for remediation purposes other than a Class V permit?	Yes	The introduction of any nutrients, ORC or other product to enhance the remediation efforts at a site requires a Class V permit	Yes	Allowances have been made on a site specific basis. State follows US EPA Region IX guidelines.		This would be directed to US EPA Region VIII
5. Is there a need to acquire a permit for a Class V well?	Yes	A Class V permit would be required for any Class V injection activities		State follows US EPA Region IX guidelines	Yes	Will follow US EPA Region VIII guidelines for these matters

G-1

## State Underground Injection Control Program Survey (1998)

STATE	DELAWARE		FLORIDA		IDAHO	
Contact Name - Number	David Reinhold (302) 739-4793		Richard Deuerling (850) 921-9417		Scott Anderson (208) 375-7956	
Question #	Yes/ No	Comment	Yes/ No	Comment	Yes/ No	Comment
1. Does your state have an established UIC (Underground Injection Control) program? If so, what agency/division oversees this program? Is there UIC primacy?	Yes	Dept. of Natural Resources and Environmental Control - Division of Water Resources - Ground Water Discharges Section; have primacy	Yes	Florida Dept. of Environmental Protection - Division of Water Facilities - Bureau of Water Facilities Regulation; have primacy	Yes	Idaho Dept. of Water Resources (IDWR) and Idaho Division of Environmental Quality (ID DEQ); have primacy
2. Does your UIC program require hydrogeologic modeling to provide proof of containment?		Not necessarily, but we might, depending on the circumstances (site specific)		Modeling is not necessarily required under the UIC program, but may be under required by other programs involved with a remediation project	No	
3. Do you allow or would you allow a Class V well to be utilized for remediation purposes (i.e. reinjection for in situ purposes)?	Yes		Yes	Appropriate water quality standards just be met prior to injection, however there are state mechanisms for relief from water quality standards	Yes	This could be allowed pending on a "consent agreement" with ID DEQ
4. Is there or could there be an allowance for injection/reinjection of amendments for remediation purposes other than a Class V permit?	Yes	There could be, however, it has never come up	No	See question #5		Refer to question #3
5. Is there a need to acquire a permit for a Class V well?	Yes			No, if the well is authorized under a Remedial Action Plan or other enforceable mechanism issue by this department; refer to State Rule 62-528.630 / General Permitting Requirements for Class V wells	Yes	IDWR provides permits, however various parameters of the remediation well(s) would have to be agreed upon by a "consent agreement" with ID DEQ

## State Underground Injection Control Program Survey (1998)

STATE	ILLINOIS		KANSAS		KENTUCKY	
Contact Name - Number	Bur Filson (217) 782-6070		Mike Cochran (785) 296-5560		Dale Burton (502) 564-6716	
Question #	Yes/ No	Comment	Yes/ No	Comment	Yes/ No	Comment
1. Does your state have an established UIC (Underground Injection Control) program? If so, what agency/division oversees this program? Is there UIC primacy?	Yes	Illinois Environmental Protection Agency; have primacy	Yes	Kansas Dept. of Health and Environment - Bureau of Water; have primacy	No	KY Dept. of Environmental Protection - Groundwater and RCRA sections are involved with these types of actions; do not have primacy
2. Does your UIC program require hydrogeologic modeling to provide proof of containment?	No	This should be provided in the technical/modeling information that is required	Yes		Yes	Provided by modeling and/or relevant data
3. Do you allow or would you allow a Class V well to be utilized for remediation purposes (i.e. reinjection for in situ purposes)?	Yes		Yes			Would evaluate individual basis based on specifics (contaminants, site characterization, etc.) of a site, but ultimately go along with US EPA's decision
4. Is there or could there be an allowance for injection/reinjection of amendments for remediation purposes other than a Class V permit?	Yes	Not if the reinjected media was hazardous, however exceptions may be possible based on a site by site basis		Not unless a permit is waved by federal or state statute, for example CERCLA/RCRA permit waivers		US EPA would have to determine
5. Is there a need to acquire a permit for a Class V well?	No	This is optional, however the agency would like to be informed of actions (to warn against possible regulatory actions, resulting from violations)	Yes	We also have a special permit application for Class V well for remediation purposes	No	The department would like to be informed of actions (to warn against possible regulatory actions, resulting from violations)

## State Underground Injection Control Program Survey (1998)

STATE	LOUISIANA		MARYLAND		MASSACHUSETTS	
Contact Name - Number	Doyle Johnson (225) 342-5526		Stanley Tsai (410) 631-4478		Russell Clifton (617) 556-1165	
Question #	Yes/ No	Comment	Yes/ No	Comment	Yes/ No	Comment
1. Does your state have an established UIC (Underground Injection Control) program? If so, what agency/division oversees this program? Is there UIC primacy?	Yes	Dept. of Natural Resources (DNR); have primacy	No	Department of Environment (MA DE) is involved in these activities; do not have primacy	Yes	MA Department of Environmental of Protection - Bureau of Resource Protection; have primacy over Class V wells
2. Does your UIC program require hydrogeologic modeling to provide proof of containment?	Yes		No	However other programs which may be involved may have different requirements		In most instances, no; however if there is reason to suspect that contamination cannot be contained, hydrogeologic modeling may be required
3. Do you allow or would you allow a Class V well to be utilized for remediation purposes (i.e. reinjection for in situ purposes)?	Yes	However, for wells injecting into a USDW, approval must be granted by the Dept. of Environmental Quality		MA DE evaluates technologies on a case-by-case basis, based on reports submitted by consultants ; however ultimately follow US EPA Region III guidelines	Yes	Reinjection must meet the requirements of, and be in full compliance with, the Massachusetts contingency plan (MCP, 310 CMR 40.0000)
4. Is there or could there be an allowance for injection/reinjection of amendments for remediation purposes other than a Class V permit?	Yes			Follow US EPA Region III guidelines		There is allowances for injection/ reinjection of amendment for remediation purposes; however, reinjection of remediated groundwater must meet strict standards as set in the MCP and or MA Drinking Water standards depend on type of reinjection
5. Is there a need to acquire a permit for a Class V well?	Yes	DNR approves well construction for all classes of disposal wells		Follow US EPA Region III guidelines		Depends, on type or purpose of Class V well

## State Underground Injection Control Program Survey (1998)

STATE	NEBRASKA		NEVADA		NEW MEXICO	
Contact Name - Number	Mary Yelken (402) 471-2181		Russ Land (702) 687-4670		Vicki Maranville (505) 827-0652	
Question #	Yes/ No	Comment	Yes/ No	Comment	Yes/ No	Comment
1. Does your state have an established UIC (Underground Injection Control) program? If so, what agency/division oversees this program? Is there UIC primacy?	Yes	NE Dept. of Environmental Quality - Ground Water Section; have primacy	Yes	Bureau of Water Pollution Control - Division of Environmental Protection; have primacy for Class II, III, and V wells	Yes	NM Environment Department (NMED) - Ground Water Quality Board; have primacy
2. Does your UIC program require hydrogeologic modeling to provide proof of containment?	Yes	Generally no modeling is required for Class V wells, but it may be required in certain situations	Yes	A simple model would be required for a Class V well UIC permit	Yes	For Class I and III wells, sometimes for Class V wells
3. Do you allow or would you allow a Class V well to be utilized for remediation purposes (i.e. reinjection for in situ purposes)?	Yes		Yes	Monitoring and sampling are required, with controls on injectant quality; this is usually in cooperation with our Corrective Action agency	Yes	Aquifer remediation wells are permitted as 5X26 Class V wells
4. Is there or could there be an allowance for injection/reinjection of amendments for remediation purposes other than a Class V permit?	Yes	One potential that would not require a UIC permit would be the open trench method, however this method would have to be approved through the specific involved program, other consideration may be made based on a case-by-case basis	Yes	No permit is required for injection of ambient air, this only requires a letter of authorization after submission of minimal information for injection of oxygen releasing compounds and ozone	Yes	Amendments are allowed but must be approved by NMED and the discharger must demonstrate WACC (Water Quality Control Commission) standards will not be violated
5. Is there a need to acquire a permit for a Class V well?	Yes		Yes	In most remediation situations	Yes	

## State Underground Injection Control Program Survey (1998)

STATE	NEW YORK		OHIO		OREGON	
Contact Name - Number	Jim Harrington (518) 457-0337		Tom Velalis (937) 285-6466		Kevin Parrett (503) 229-6748	
Question #	Yes/ No	Comment	Yes/ No	Comment	Yes/ No	Comment
1. Does your state have an established UIC (Underground Injection Control) program? If so, what agency/division oversees this program? Is there UIC primacy?	No	Dept. of Environmental Conservation - SDEC; do not have primacy but rather own set of UIC regulation, referred to as SPDES (State Pollutes and Discharge Elimination)	Yes	OH Dept. of Natural Resources and OH EPA; have primacy	Yes	Department of Environmental Quality - Water Quality Division; have primacy
2. Does your UIC program require hydrogeologic modeling to provide proof of containment?		We don't have a written policy on what the demonstration must contain but modeling would be beneficial to the understanding and approval process	Yes			
3. Do you allow or would you allow a Class V well to be utilized for remediation purposes (i.e. reinjection for in situ purposes)?		We have allowed injection of various amendments for remediation purposes but have generally required that there be a demonstration that groundwater standards not be violated at any point	Yes	Aquifer remediation is classified under 5X26 Class V wells	No	
4. Is there or could there be an allowance for injection/reinjection of amendments for remediation purpose other than a Class V permit?			Yes	If reinjection involves contaminated groundwater that exceeds MCLs, a permit to inject (PTI) or permit to operate (PTO) can be applied for	Yes	Certain UIC situation can be granted a waiver for water quality requirements, reviewed on a case-by-case basis
5. Is there a need to acquire a permit for a Class V well?	No	However, the Department would like to be informed of such actions, to warning against any regulatory actions provoked by violation(s)		A formal permit is not needed if contaminants are below MCLs, however if they exceed MCLs then a permit is required (see question # 4)		Granted as a Cleanup Permit, refer to question # 4



## State Underground Injection Control Program Survey (1998)

STATE	PENNSYLVANIA		TENNESSEE		TEXAS	
Contact Name - Number	Joe Lee (717) 772-4018		Scotty Sorrells (615) 532-9224		Ben Knappe (512) 239-6633	
Question #	Yes/ No	Comment	Yes/ No	Comment	Yes/ No	Comment
1. Does your state have an established UIC (Underground Injection Control) program? If so, what agency/division oversees this program? Is there UIC primacy?	No	Injection of amendments <u>may</u> involve the water management and the environmental cleanup programs of State Regional Offices - Department of Environmental Protection	Yes	Department of Environment and Conservation - Division of Water Supply; currently attaining primacy	Yes	Various division with in Texas Natural Resource and Conservation Commission
2. Does your UIC program require hydrogeologic modeling to provide proof of containment?	No	See #1, in addition DEP may require the consultant to demonstrate that nutrients/amendments in a remediation system will be consumed and not leave the site		Each site will be evaluated on an individual basis	Yes	Modeling and monitoring data are requested
3. Do you allow or would you allow a Class V well to be utilized for remediation purposes (i.e. reinjection for in situ purposes)?		Possibly, individual regions make site-specific decision regarding the use of injection wells for remediation purposes; use of amendments is typically assessed as part of a remediation plan by the Environmental Cleanup program		At this time there are several injection wells working on remediation sites in Tennessee, sites are currently being addressed on a site specific basis		
4. Is there or could there be an allowance for injection/reinjection of amendments for remediation purpose other than a Class V permit?		See question #3		Each site is reviewed on an individual basis and all injection into the subsurface will require a permit	Yes	Reviewed on a case-by-case basis, classified as "aquifer restoration"
5. Is there a need to acquire a permit for a Class V well?	No	US EPA reporting requirements and applicable new regulations would apply; however a regional office may require a Part II water quality management discharge permit for the injection of nutrients	Yes		No	Class V wells are authorized by rule, if the reinjection process represents a threat to a drinking water supply the TNRCC will delegate over

## State Underground Injection Control Program Survey (1998)

STATE	UTAH		VIRGINIA		WASHINGTON	
Contact Name - Number	Jerry Jackson (801) 538-6146		Erica Dameron (804) 698-4201		Mary Shaleen-Hansen (360) 407-6143	
Question #	Yes/ No	Comment	Yes/ No	Comment	Yes/ No	Comment
1. Does your state have an established UIC (Underground Injection Control) program? If so, what agency/division oversees this program? Is there UIC primacy?	Yes	Department of Environmental Quality	No	Some aspects may be addressed by the Dept. of Environmental Quality - Groundwater Division	Yes	Dept. of Ecology - Water Quality Program; have primacy
2. Does your UIC program require hydrogeologic modeling to provide proof of containment?	No	Modeling is optional		Follow US EPA's protocol	Yes	Modeling is required if the discharge it to stay with in the boundary of a site
3. Do you allow or would you allow a Class V well to be utilized for remediation purposes (i.e. reinjection for in situ purposes)?	No	Reinjected water must not exceed MCLs		Follow US EPA's protocol	Yes	MCLs still must be considered; sites can be evaluated on an individual basis
4. Is there or could there be an allowance for injection/reinjection of amendments for remediation purposes other than a Class V permit?	No	See question # 3		Follow US EPA's protocol		Refer to question #3
5. Is there a need to acquire a permit for a Class V well?	No	These wells are authorized by rule; the Department would like inventory reports to be submitted before the project begins		Follow US EPA's protocol (Class V are authorized by rule)	Yes	