

Final Report

Pilot Region-Based Optimization Program for Fund-Lead Sites in EPA Region 3

Site Optimization Tracker: Hellertown Manufacturing Hellertown, Pennsylvania

EPA Region III



Solid Waste and
Emergency Response
(5102P)

EPA 542-R-06-006e
December 2006
www.epa.gov

Pilot Region-Based Optimization Program for Fund-Lead Sites in EPA Region 3

Site Optimization Tracker: Hellertown Manufacturing Hellertown, Pennsylvania

EPA Region III

Site Optimization Tracker:
Hellertown Manufacturing
Hellertown, Pennsylvania

EPA Region III

December 30, 2005

SECTION 1:

CURRENT SITE INFORMATION FORM

Date: 12/30/05 Filled Out By: GeoTrans, Inc.

A. Site Location, Contact Information, and Site Status		
1. Site name Hellertown Manufacturing	2. Site Location (city and State) Hellertown, PA	3. EPA Region 3
4a. EPA RPM Alexis Hanlon	5a. State Contact Margaret Boyer	
4b. EPA RPM Phone Number 215-814-5146	5b. State Contact Phone Number 610-861-2076	
4c. EPA RPM Email Address hanlon.alexis@epa.gov	5c. State Contact Email Address boyer.margaret@dep.state.pa.us	
5. Is the ground water remedy an interim remedy or a final remedy? Interim <input type="checkbox"/> Final <input checked="" type="checkbox"/>		
6. Is the site EPA lead or State-lead with Fund money? EPA <input checked="" type="checkbox"/> State <input type="checkbox"/>		
B. General Site Information		
1a. Date of Original ROD for Ground Water Remedy 9/3/1991	1b. Dates of Other Ground Water Decision Documents (e.g., ESD, ROD Amendment)	
2a. Date of O&F 9/26/1997	2b. Date for transfer to State 9/25/2007	
3. What is the primary goal of the P&T system (select one)?	4. Check those classes of contaminants that are contaminants of concern at the site.	
<input type="checkbox"/> Contaminant plume containment <input type="checkbox"/> Aquifer restoration <input checked="" type="checkbox"/> Containment and restoration <input type="checkbox"/> Well-head treatment	<input checked="" type="checkbox"/> VOCs (e.g., TCE, benzene, etc.) <input type="checkbox"/> SVOCs (e.g., PAHs, PCP, etc.) <input type="checkbox"/> metals (e.g., arsenic, chromium, etc.) <input type="checkbox"/> other	
5. Has NAPL or evidence of NAPL been observed at the site? Yes <input type="checkbox"/> No <input checked="" type="checkbox"/>		
6. What is the approximate total pumping rate?	125 gpm	
7. How many active extraction wells (or trenches) are there? 1	8. How many monitoring wells are regularly sampled? 20	
9. How many samples are collected from monitoring wells or piezometers each year? (e.g., 40 if 10 wells are sampled quarterly) 40	10. How many process monitoring samples (e.g., extraction wells, influent, effluent, etc.) are collected and analyzed each year? (e.g., 24 if influent and effluent are sampled monthly) 8	
11. What above-ground treatment processes are used (check all that apply)?		
<input checked="" type="checkbox"/> Air stripping <input type="checkbox"/> Carbon adsorption <input checked="" type="checkbox"/> Filtration <input checked="" type="checkbox"/> Off-gas treatment <input type="checkbox"/> Ion exchange	<input type="checkbox"/> Metals precipitation <input type="checkbox"/> Biological treatment <input type="checkbox"/> UV/Oxidation <input type="checkbox"/> Reverse osmosis <input type="checkbox"/> Other	
12. What is the approximate percentage of system downtime per year? 10% <input checked="" type="checkbox"/> 10 - 20% <input type="checkbox"/> >20% <input type="checkbox"/>		

C. Site Costs			
1. Annual O&M costs			
O&M Category	Actual¹ Annual Costs for FY04	Estimated² Annual Costs for FY05	Estimated² Annual Costs for FY06
Labor: project management, reporting, technical support	\$32,000	\$33,500	\$33,500
Labor: system operation	\$11,000	\$8,000	\$8,000
Labor: ground water sampling	\$25,000	\$25,000	\$25,000
Utilities: electricity	\$9,200	\$9,000	\$9,000
Utilities: other	\$2,250	\$3,000	\$3,000
Consumables (GAC, chemicals, etc.)	\$10,500	\$9,000	\$9,000
Discharge or disposal costs	0	\$700	\$700
Analytical costs	\$5,000*	\$5,000*	\$5,000*
Other (parts, routine maintenance, etc.)	\$24,000	\$20,000	\$20,000
O&M Total	\$118,950	\$113,200	\$113,200
<i>The O&M total should be equal to the total O&M costs for the specified fiscal years, including oversight from USACE or another contractor. For costs that do not fit in one of the above cost categories, include them in the "Other" category. If it is not possible to break out the costs into the above categories, use the categories as best as possible and provide notes in the following box.</i>			
2. Non-routine or other costs	\$82,040	\$50,000	\$25,000**
<i>Additional costs beyond routine O&M for the specified fiscal years should be included in the above spaces. Such costs might be associated with additional investigations, non-routine maintenance, additional extraction wells, or other operable units. The total costs billed to the site for the specified fiscal years should be equal to the O&M total plus the costs entered in item 2.</i>			
Notes on costs:			
<p>1. Costs, with the exception of the analytical costs, were provided by the RPM.</p> <p>2. FY05 and FY06 annual costs, with the exception of the analytical costs, were projected by the RPM.</p> <p>* Analytical costs were estimated by the ROET based on the sampling program. The analytical costs are not incurred by the EPA site team because the samples are analyzed by the CLP program. However, analytical costs similar to those estimated by the ROET, will likely be incurred by the State if/when the site is transferred to the State after LTRA. The decrease from FY05 to FY06 reflects a sampling reduction undertaken by the site team.</p> <p>** The non-routine costs for FY06 are estimated by the ROET and represent potential contractor support costs that might be associated with obtaining institutional controls for the site or other items associated with implementing optimization evaluation recommendations.</p>			

D. Five-Year Review

1. Date of the Most Recent Five-Year Review **4/29/2005**

2. Protectiveness Statement from the Most Recent Five-Year Review

Protective

Not Protective

Protective in the short-term

Determination of Protectiveness Deferred

3. Please summarize the primary recommendations in the space below

This new Five Year Review was not provided to the ROET in enough time for consideration during this project. The RPM reports that the Five Year Review states that the remedy is protective in the short-term. The majority of the recommendations from the previous Five Year Review have been implemented, but the site team is still working toward institutional controls, which is the primary reason that the remedy is only considered protective in the short term.

E. Other Information

If there is other information about the site that should be provided please indicate that information in the space below. Please consider enforcement activity, community perception, technical problems to be addressed, and/or areas where a third-party perspective may be valuable.

This updated form reflects the following changes from the baseline information form.

- changes in the RPM's and State Contact's last names
- a correction regarding the O&F date for the system and the date of transfer to the State
- a reduction in the process sampling to quarterly sampling of the influent and effluent
- a Five Year Review was conducted in April 2005.

SECTION 2:

FOLLOW-UP HISTORY AND SUMMARIES

Note: Follow-up summaries are provided in reverse chronological order and include updated and/or new recommendations.

FOLLOW-UP HISTORY

Date of Original Optimization Evaluation	June 5, 2001 (site visit) November 14, 2001 (report)
---	---

	<u>Meeting Date</u>	<u>Report Date</u>	<u>Item</u>
<input checked="" type="checkbox"/>	May 29, 2002	June 10, 2002	Follow-Up A* (part of nationwide opt. effort)
<input checked="" type="checkbox"/>	June 11, 2003	June 30, 2003	Follow-Up B* (part of nationwide opt. effort)
<input checked="" type="checkbox"/>	December 16, 2004	January 24, 2005	Follow-Up #1 (conducted as part of pilot project)
<input checked="" type="checkbox"/>	October 18, 2005	December 30, 2005	Follow-Up #2 (conducted as part of pilot project)
<input type="checkbox"/>			Follow-Up #3
<input type="checkbox"/>			Follow-Up #4
<input type="checkbox"/>			Follow-Up #5
<input type="checkbox"/>			Follow-Up #6

“x” in box indicates the item has been completed

* Follow-up A and B were performed as part of a nationwide optimization effort, separate from the pilot project under which Follow-up #1 and #2 were conducted.

SUMMARY OF FOLLOW-UP #2

Site or System Name	Hellertown Manufacturing
Date of This Follow-Up Summary	December 30, 2005
Date of Follow-Up Meeting or Call (Indicate if Meeting or Call)	October 18, 2005 – Meeting

ROET MEMBERS CONDUCTING THE FOLLOW-UP EVALUATION:

Name	Affiliation	Phone	Email
Kathy Davies	U.S. EPA Region 3	215-814-3315	davies.kathy@epa.gov
Norm Kulujian	U.S. EPA Region 3	215-814-3130	kulujian.norm@epa.gov
Peter Ludzia	U.S. EPA Region 3	215-814-3224	ludzia.peter@epa.gov
Peter Rich	GeoTrans, Inc.	410-990-4607	prich@geotransinc.com
Rob Greenwald	GeoTrans, Inc.	732-409-0344	rgreenwald@geotransinc.com
Doug Sutton	GeoTrans, Inc.	732-409-0344	dsutton@geotransinc.com
Kathy Yager	U.S. EPA OSRTI	617-918-8362	yager.kathleen@geotransinc.com
Chuck Sands	U.S. EPA OSRTI	703-603-8857	sands.charles@epamail.epa.gov

SITE TEAM MEMBERS (INCLUDING CONTRACTORS) INTERVIEWED

Name	Affiliation	Phone	Email
Alexis Hanlon	U.S. EPA Region 3 (RPM)	215-814-5146	Hanlon.alexis@epa.gov
Mindy Snoparsky	U.S. EPA Region 3 (Hydrogeologist)	215-814-3316	snoparsky.mindy@epa.gov

IMPLEMENTATION STATUS OF ALL RECOMMENDATIONS UNDER CONSIDERATION BUT NOT PREVIOUSLY IMPLEMENTED

Recommendation	E-6.1.1 Analyze Capture Zone for Ground Water Extraction Well		
Recommendation Reason	Effectiveness	Implementation Status	Substantial progress
<p>Comments: A capture zone analysis using water level measurements has been conducted. The results suggest that capture is adequate; however, the analysis was based on limited data. A better indicator of capture would be from a water budget analysis and from reviewing concentration trends of downgradient performance wells installed somewhere between the extraction well and existing downgradient wells. The site team gained access to the Norfolk railroad property in 2005 and installed a new monitoring well approximately 100 feet downgradient of the extraction well. The new monitoring well has been sampled, and the site team is awaiting the sampling results. The cost for well installation and sampling was approximately \$15,000.</p>			
Recommendation	E-6.1.3 Implement Institutional Controls		
Recommendation Reason	Effectiveness	Implementation Status	In progress
<p>Comments: The current property owner, Paikes, has been contacted regarding continued access and institutional controls. Although initial efforts suggested that Paikes would implement the institutional controls, negotiations between EPA and Paikes have since stopped. EPA is now working with the State to see if the State will implement specific institutional controls through a 512 order.</p>			
Recommendation	E-6.4.1 Establish Cleanup Goals for the Aquifer		
Recommendation Reason	Site Closeout	Implementation Status	Substantial progress
<p>Comments: The RPM has conferred with the Regional toxicologists. After addressing recommendation 6.1.3, the RPM will issue an ESD documenting MCLs as the cleanup levels for the site.</p>			
Recommendation	1F-1 Excavate Soils Near CSP-7		
Recommendation Reason	Effectiveness	Implementation Status	Alternative Implemented
<p>Comments: Investigation of the former pre-treatment area was conducted by the site team in response to Recommendation 6.1.4. A soil gas survey indicated soil contamination as high as 240 mg/kg, and in the December 2004 follow-up meeting, the ROET concurred with the site team that excavation was appropriate. The site team was planning to excavate approximately 40,000 cubic feet of soil in the Summer 2005; however, prior to the excavation, sampling indicated that the concentrations at the nearby monitoring well dropped to 12 ug/L (from over 200 ug/L) indicating the excavation may not be necessary. The site team will continue to track the sampling results from this area.</p>			

Recommendation	1F-2 Install Planned Monitoring Wells Downgradient of Capture Zone		
Recommendation Reason	Effectiveness	Implementation Status	Implemented
Comments: A monitoring wells was installed approximately 100 feet downgradient of the extraction, which based on the technical assistance (see Appendix A) should be downgradient of the capture zone. For additional information, please refer to the comments associated with recommendation 6.1.1.			

Key for recommendation numbers:

- *E denotes a recommendation from the original optimization evaluation*
- *F1, F2, etc. denote recommendations from the first, second, etc. follow-up meeting*
- *The number corresponds to the number of the recommendation as stated in the optimization evaluation or follow-up summary where the recommendation was provided*

RECOMMENDATIONS PREVIOUSLY IMPLEMENTED OR THAT WILL NOT BE IMPLEMENTED

Recommendation	E-6.1.2 Evaluate Extraction Well Production		
Recommendation Reason	Effectiveness	Implementation Status	Implemented
Comments: The well has been inspected with a downhole camera and has been rehabilitated. The flow rate has been at approximately 130 gpm for over a year and a half. This is an increase of approximately 50% compared to the flow rate at the time of the RSE. The site team has had to replace the pump frequently resulting in costs of approximately \$10,000 per year. The ROET provided information on more competitive costs for potential pump replacements as part of a technical assistance item (see Appendix A). The last pump change was conducted in October 2004, and the next one will likely occur in Fall 2006. The site team will likely use the pump discussed in the technical assistance item.			
Recommendation	E-6.1.4 Evaluate Pretreatment Area		
Recommendation Reason	Effectiveness	Implementation Status	Implemented
Comments: A soil gas survey indicated soil contamination as high as 240 mg/kg. The site team was planning to excavate approximately 40,000 cubic feet of soil in the Summer 2005; however, prior to the excavation, sampling indicated that the concentrations at the nearby monitoring well dropped to 12 ug/L (from over 200 ug/L) indicating the excavation may not be necessary.			
Recommendation	E-6.2.1 Consider Modifying Treatment Processes to Liquid Phase Carbon Only		
Recommendation Reason	Cost Reduction	Implementation Status	Will not be implemented
Comments: The recommendation will be considered only if replacing the air stripper or other significant changes are required.			

Recommendation	E-6.2.2 Lower Building Temperature to Lower Utility Costs		
Recommendation Reason	Cost Reduction	Implementation Status	Implemented
Comments: The temperature has been lowered and the site team has identified savings of approximately \$2,000 per year in lower utility costs.			
Recommendation	E-6.3.1 Stop Performing Data Validation		
Recommendation Reason	Technical Improvement	Implementation Status	Implemented
Comments: Data validation has been reduced to the M-1 level, which is the lowest level. The costs of data validation are not assigned to the site because the samples are analyzed by the CLP.			

Key for recommendation numbers:

- *E denotes a recommendation from the original optimization evaluation*
- *F1, F2, etc. denote recommendations from the first, second, etc. follow-up meeting*
- *The number corresponds to the number of the recommendation as stated in the optimization evaluation or follow-up summary where the recommendation was provided*

OTHER CHANGES, UPDATES, OR SIGNIFICANT FINDINGS SINCE LAST FOLLOW-UP

A Five Year Review for the site was completed in April 2005 but was not provided to the ROET in time for consideration in this pilot project.

NEW OR UPDATED RECOMMENDATIONS FROM THIS FOLLOW-UP

None.

SUMMARY OF FOLLOW-UP #1

Site or System Name	Hellertown Manufacturing
Date of This Follow-Up Summary	January 24, 2005
Date of Follow-Up Meeting or Call (Indicate if Meeting or Call)	December 16, 2004 – Meeting

ROET MEMBERS CONDUCTING THE FOLLOW-UP EVALUATION:

Name	Affiliation	Phone	Email
Kathy Davies	U.S. EPA Region 3	215-814-3315	davies.kathy@epa.gov
Norm Kulujian	U.S. EPA Region 3	215-814-3130	kulujian.norm@epa.gov
Peter Schaul	U.S. EPA Region 3	215-814-3183	schaul.peter@epa.gov
Peter Rich	GeoTrans, Inc.	410-990-4607	prich@geotransinc.com
Rob Greenwald	GeoTrans, Inc.	732-409-0344	rgreenwald@geotransinc.com
Doug Sutton	GeoTrans, Inc.	732-409-0344	dsutton@geotransinc.com
Jean Balent (by phone)	U.S. EPA OSRTI	703-603-9924	balent.jean@epamail.epa.gov
Chuck Sands	U.S. EPA OSRTI	703-603-8857	sands.charles@epamail.epa.gov

SITE TEAM MEMBERS (INCLUDING CONTRACTORS) INTERVIEWED

Name	Affiliation	Phone	Email
Alexis Hanlon	EPA Region 3 (RPM)	215-814-5146	hanlon.alexis@epa.gov
Jim Romig	CDM Federal	610-293-0450	RomigJM@cdm.com

IMPLEMENTATION STATUS OF PREVIOUSLY IDENTIFIED RECOMMENDATIONS

Recommendation	6.1.1 Analyze Capture Zone for Ground Water Extraction Well		
Recommendation Reason	Effectiveness	Implementation Status	Substantial progress
Comments: A capture zone analysis using water level measurements has been conducted. The results suggest that capture is adequate; however, the analysis was based on limited data. A better indicator of capture would be from a water budget analysis and from reviewing concentration trends of downgradient performance wells installed somewhere between the extraction well and existing downgradient wells. The site team is waiting for access to the Norfolk railroad property to install the wells.			
Recommendation	6.1.2 Evaluate Extraction Well Production		
Recommendation Reason	Effectiveness	Implementation Status	Implemented
Comments: The well has been inspected with a downhole camera and has been rehabilitated. The flow rate has been at approximately 130 gpm for over a year and a half. This is an increase of approximately 50% compared to the flow rate at the time of the RSE. The site team has had to replace the pump frequently resulting in costs of approximately \$10,000 per year. The RPM has requested advice on alternatives for the current pump.			
Recommendation	6.1.3 Implement Institutional Controls		
Recommendation Reason	Effectiveness	Implementation Status	In progress
Comments: The current property owner, Paikes, has been contacted regarding continued access and institutional controls. Paikes seems willing to cooperate. The idea is to have Paikes implement the institutional controls on their own so that EPA does not have to have an interest in the property to implement them itself.			
Recommendation	6.1.4 Evaluate Pretreatment Area		
Recommendation Reason	Effectiveness	Implementation Status	Implemented
Comments: A soil gas survey indicated soil contamination as high as 240 mg/kg. The site team is planning to excavate approximately 40,000 cubic feet of soil. The work will likely be conducted in Summer 2005.			
Recommendation	6.2.1 Consider Modifying Treatment Processes to Liquid Phase Carbon Only		
Recommendation Reason	Cost Reduction	Implementation Status	Will not be implemented
Comments: The recommendation will be considered only if replacing the air stripper or other significant changes are required.			
Recommendation	6.2.2 Lower Building Temperature to Lower Utility Costs		
Recommendation Reason	Cost Reduction	Implementation Status	Implemented
Comments: The temperature has been lowered and the site team has identified savings of approximately \$2,000 per year in lower utility costs.			

Recommendation	6.3.1 Stop Performing Data Validation		
Recommendation Reason	Technical Improvement	Implementation Status	Implemented
Comments: Data validation has been reduced to the M-1 level, which is the lowest level. The costs of data validation are not assigned to the site because the samples are analyzed by the CLP.			
Recommendation	6.4.1 Establish Cleanup Goals for the Aquifer		
Recommendation Reason	Site Closeout	Implementation Status	In progress
Comments: The RPM is working with the EPA toxicologist. They are working towards a standard of 5 ug/L for TCE but first need to demonstrate that TCE is the only contaminant of concern with a carcinogenic risk.			

OTHER CHANGES, UPDATES, OR SIGNIFICANT FINDINGS SINCE LAST FOLLOW-UP

None.

NEW OR UPDATED RECOMMENDATIONS FROM THIS FOLLOW-UP

1. It is recommended that the site team proceed with excavation of the contaminated soil near CSP-7. No further sampling for metals should be necessary given that there is no history of metals contamination at the site. The site team would be more likely to find elevated concentrations of metals that are not associated with the site.
2. When installing the new wells downgradient of the extraction well, the wells should be placed beyond the stagnation point of the capture zone. The calculations in Appendix A suggest a range of likely locations for the stagnation point when pumping at 135 gpm, assuming the aquifer is 200 feet deep, there is a hydraulic gradient of 0.03 feet per foot, and the transmissivity ranges from approximately 4,300 to 4900 ft² per day (high and low estimates from site documents). The calculations suggest that the stagnation point is at 28 to 32 feet downgradient of the extraction well. The transmissivity could easily fall outside of the above-mentioned range. To be conservative, it is suggested that the site team place the proposed monitoring wells at least 100 feet downgradient of the extraction well. Based on site maps and discussions during the followup meeting on 12/16/04, the proposed locations indicated are much further downgradient and should be sufficiently conservative to avoid installing the new monitoring wells within the capture zone.

ADDITIONAL TECHNICAL ASSISTANCE ITEMS

At the request of the RPM, information on a replacement pump is provided in Appendix A.

Updated Cost Summary Table

Recommendation	Reason	Implementation Status	Estimated Capital Costs (\$)	Actual Capital Costs (\$)	Estimated Change in Annual Costs (\$/yr)	Actual Change in Annual Costs (\$/yr)
Original Optimization Evaluation Recommendations						
6.1.1 Delineate plume and evaluate capture zone	Effectiveness	Substantial progress	\$25,000		\$5,000	
6.1.2 Evaluate extraction well and pump	Effectiveness	Implemented	\$10,000	Not quantified	\$0	Not quantified
6.1.3 Implement institutional controls	Effectiveness	In progress	\$15,000		\$0	
6.1.4 Initial investigation near CSP-7 and old treatment area	Effectiveness	Implemented	\$25,000	\$30,000 to \$45,000	\$0	Not quantified
6.2.1 a) Switch to only liquid-phase carbon b) Further reduce process monitoring	Cost Reduction	Will not be implemented	\$125,000	Will not be implemented	(\$22,000) (\$10,000)	Will not be implemented
6.2.2 Reduce heating in building (lower temperature)	Cost Reduction	Implemented	\$0	\$0	(\$1,000)	(\$2,000)
6.3.1 Stop performing data validation	Technical improvement	Implemented	\$0	\$0	\$0	\$0
6.4.1 Establish cleanup levels	Site Closure	Substantial progress	\$0	\$0	\$0	\$0
New or Updated Recommendations from Follow-up A, May 29, 2002						
None.						

New or Updated Recommendations from Follow-up B, June 11, 2003						
None.						
New or Updated Recommendations from Follow-up #1, December 16, 2004						
1. Move directly to soil excavation near CSP-7	Site closure	Alternative implemented	Not quantified	\$0	\$0	\$0
2. Install monitoring well beyond capture zone stagnation point	Effectiveness	Implemented	\$10,000	\$15,000	\$0	\$0
New or Updated Recommendations from Follow-up #2, October 18, 2005						
None.						

Costs in parentheses imply cost reductions.

APPENDIX: A

ARCHIVE OF TECHNICAL ASSISTANCE PROVIDED BY THE ROET

Note: Technical assistance items are provided in reverse chronological order.

Technical Assistance Item #2
Presented January 24, 2005

Calculation of the capture zone stagnation point

The spreadsheet and chart on the following pages calculates the estimated distance between the extraction well and the capture zone stagnation point.

Capture Zone Width Calculation, One Extraction Well

Capture Zone Width Calculations provide an estimate of capture zone width for a specific pumping rate of one or more extraction well(s). For the case of one extraction well, the equation is as follows:

$$x = -y / \tan\left(\frac{2\pi Ti}{Q} y\right) \quad - \text{or} - \quad y = \pm \left(\frac{Q}{2Ti}\right) - \left(\frac{Q}{2\pi Ti}\right) \tan^{-1}\left(\frac{y}{x}\right)$$

$$X_0 = -Q / 2\pi Ti; Y_{\max} = \pm Q / 2Ti; Y_{\text{well}} = \pm Q / 4Ti$$

Where:

T = transmissivity (ft²/day)

Q = extraction rate (ft³/day)

i = regional (i.e., without remedy pumping) hydraulic gradient (ft/ft)

tan() and tan⁻¹() are in radians, not degrees

X₀ = stagnation point, the downgradient end of the capture zone by solving for x at y=0

Y_{max} = maximum capture half width, the half distance far upstream from the well by solving for y at x=∞

Y_{well} = capture half width at well, the half distance of the capture zone at the line of well by solving for y at x=0

Assumptions applied for this method:

1. homogeneous, isotropic aquifer of infinite extent
2. confined aquifer, uniform aquifer thickness
3. fully penetrating extraction well(s)
4. uniform regional horizontal hydraulic gradient
5. steady-state flow
6. negligible vertical gradient
7. no net recharge, or net recharge is accounted for in the regional hydraulic gradient
8. no other sources of water to the extraction well (e.g., flux from rivers or from other aquifers)

Capture Zone Width Calculation Results (Low T)			
Input Parameters		Output Parameters	
Transmissivity T (ft ² /day)	4325	Stagnation Distance X ₀ (ft)	-31.88
Pumping Rate Q (gpm)	135	Max Capture Half Width Y _{max} (ft)	100.14
Pumping Rate Q (ft ³ /day)	25,900	Capture Half Width at Well Y _{well} (ft)	50.07
Hydraulic Gradient i (ft/ft)	0.03		

Capture Zone Width Calculation Results (High T)			
Input Parameters		Output Parameters	
Transmissivity T (ft ² /day)	4871	Stagnation Distance X ₀ (ft)	-28.30
Pumping Rate Q (gpm)	135	Max Capture Half Width Y _{max} (ft)	88.92
Pumping Rate Q (ft ³ /day)	25,900	Capture Half Width at Well Y _{well} (ft)	44.46
Hydraulic Gradient i (ft/ft)	0.03		

Capture Zone Width Calculation Results

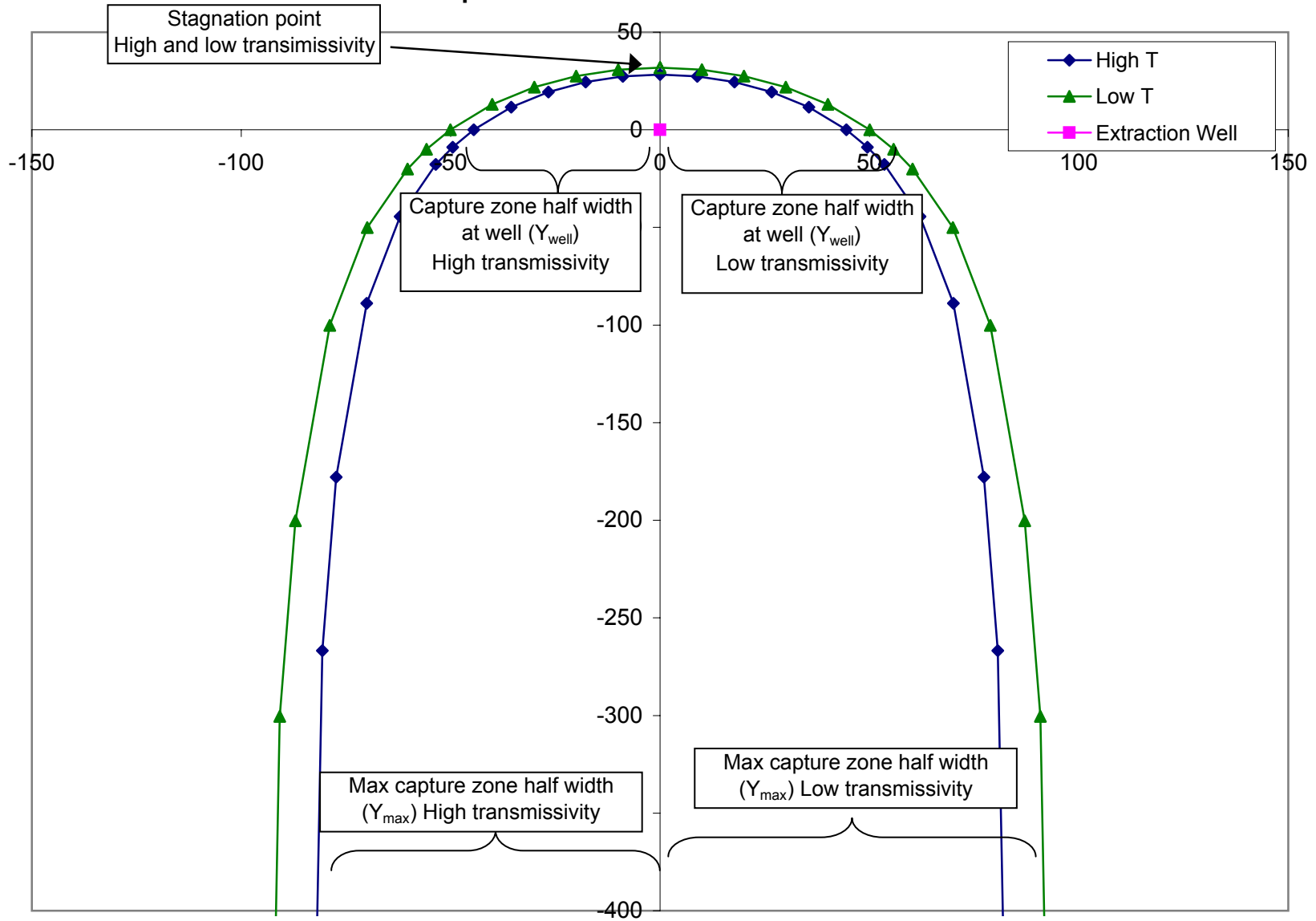

Technical Assistance Item #1
Presented January 24, 2005

Information regarding replacement pumps for the extraction well

A contact from Pumps-On-Line (877-863-5360), provided a quote of \$2,800 (for pump and motor) delivered to the site via common carrier. Please note that the attached quote of \$4,320 is the Grundfos list price and that the \$2,800 reflects a discount offered by the vendor. Actual installation costs would be somewhat higher, but should be under \$10,000. A comparable Goulds pump (6DLC020 or 150L15 6 stage) was not available from the same vendor, but list prices quotes obtained directly from Goulds ranged from \$4,000 to \$4,700.

Installation and input

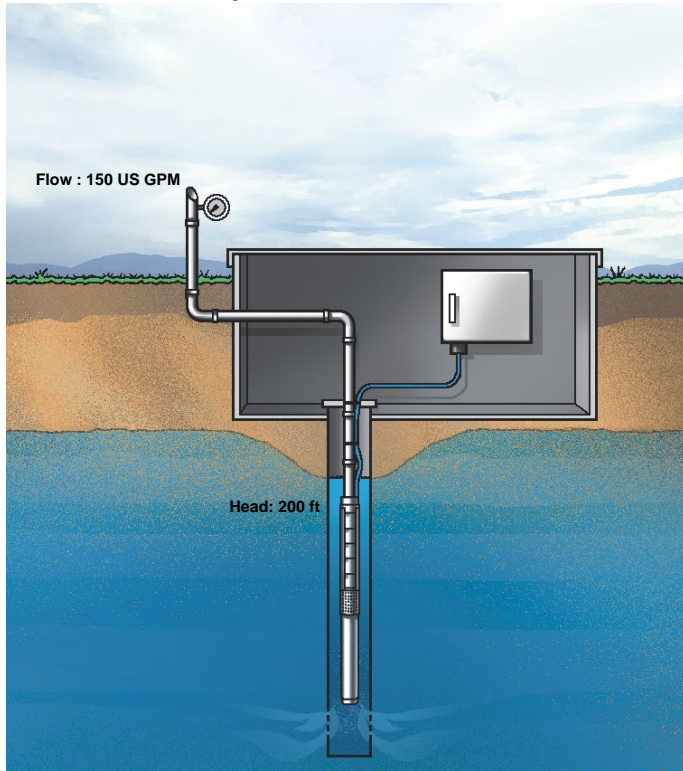

Products

1 x 150S150-6

Prod.No.: 13B73606

Sizing Results

Flow:	168 US GPM (32883650 US gal/year)
Total head:	200 ft
Power P1:	10.9 kW
Power P2:	11.8 HP
Efficiency pump:	72.0 %
Efficiency motor:	81.0 %
Efficiency total:	58.3 %
Consumption:	39810 kWh/Year
Specific energy consumption:	1.2108 kWh/1000 gal (4.63 kWh/gal/ft)
Energy costs:	2787 \$/Year
Motor type:	Super - 6"
Phase:	3
Voltage:	460 V
Frequency:	60 Hz
Current (rated):	23.7 A
Current (actual):	23.7 A
Cos phi (actual):	0.85

Pump Curve

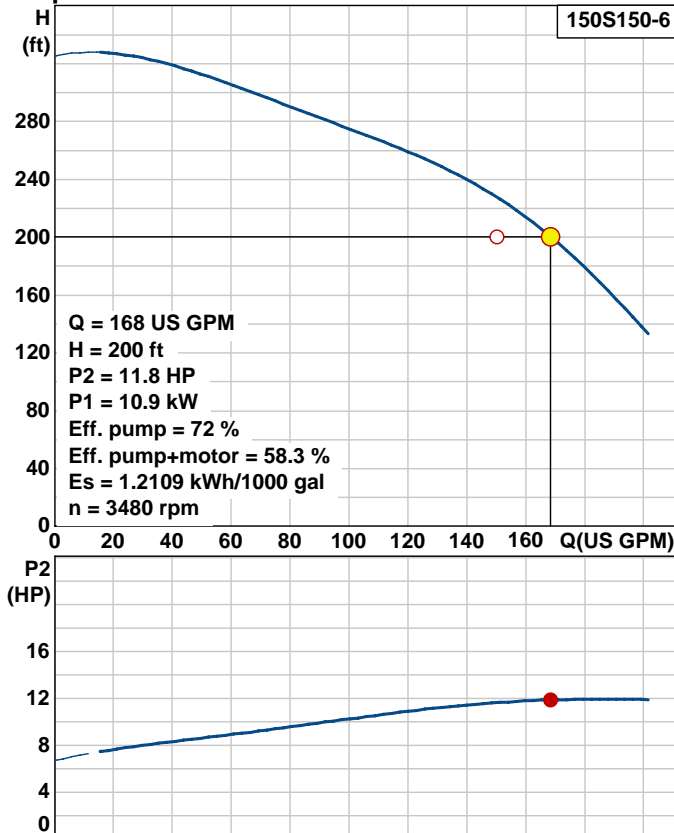

Dimensional Drawing

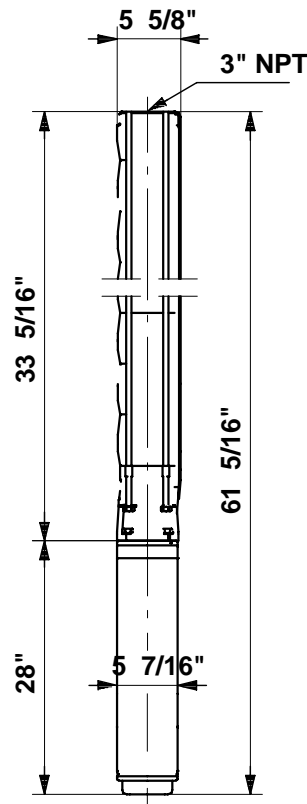



Company name: Pumps Online, Inc
 Created by: David
 Phone: (877) 863-5360
 Fax: (630) 355-5604
 Date: 1/11/2005

Position	Count	Description	Single Price
	1	<p>150S150-6</p>  <p>Note! Product picture may differ from actual product</p> <p>Product No.: 13B73606 Multi-stage submersible pump for raw water supply, groundwater lowering and pressure boosting. The pump is suitable for pumping clean, thin, non-aggressive liquids without solid particles or fibres.</p> <p>The pump is made entirely of Stainless steel DIN W.-Nr. 1.4301 DIN W.-Nr. and suitable for horizontal as well as vertical installation. The pump is fitted with a built-in non-return valve.</p> <p>The motor is a 3-phase motor of the canned type with sand shield, liquid-lubricated bearings and pressure equalizing diaphragm.</p> <p>Liquid: Max liquid t at 0.08 m/sec: 86 °F Pumped liquid: Drinking water</p> <p>Technical: Rated flow: 150 US GPM Flow (Pump): 168 US GPM Rated head: 226 ft Head: 200 ft</p> <p>Materials: Material, pump: Stainless steel 1.4301 DIN W.-Nr. 304 AISI Material, impeller: Stainless steel 1.4301 DIN W.-Nr. 304 AISI Material, motor: Stainless steel 1.4301 DIN W.-Nr. 304 AISI</p> <p>Installation: System pressure: 1450 psi Min inlet pressure: -5.3 psi Minimum pre-charge pressure: 0 psi Size, pump outlet: 3" NPT Motor diameter: 6" inch Minimum borehole diameter: 6" in</p> <p>Electrical data: Motor type: Super - 6"</p>	\$ 4,320.00



Company name: Pumps Online, Inc
Created by: David
Phone: (877) 863-5360
Fax: (630) 355-5604
Date: 1/11/2005

Position	Count	Description	Single Price
		<p>P2 :15 HP Mains frequency:60 Hz Rated voltage:3 x 460 V Starting method:direct-on-line Service factor:1,15 Rated current:20.8 A 23.7 A Starting current:133 A Cos phi - power factor:0,85 Rated speed:3450 rpm Full load motor efficiency:81,0 %</p>	



Company name: Pumps Online, Inc
Created by: David
Phone: (877) 863-5360
Fax: (630) 355-5604
Date: 1/11/2005

13B73606 150S150-6

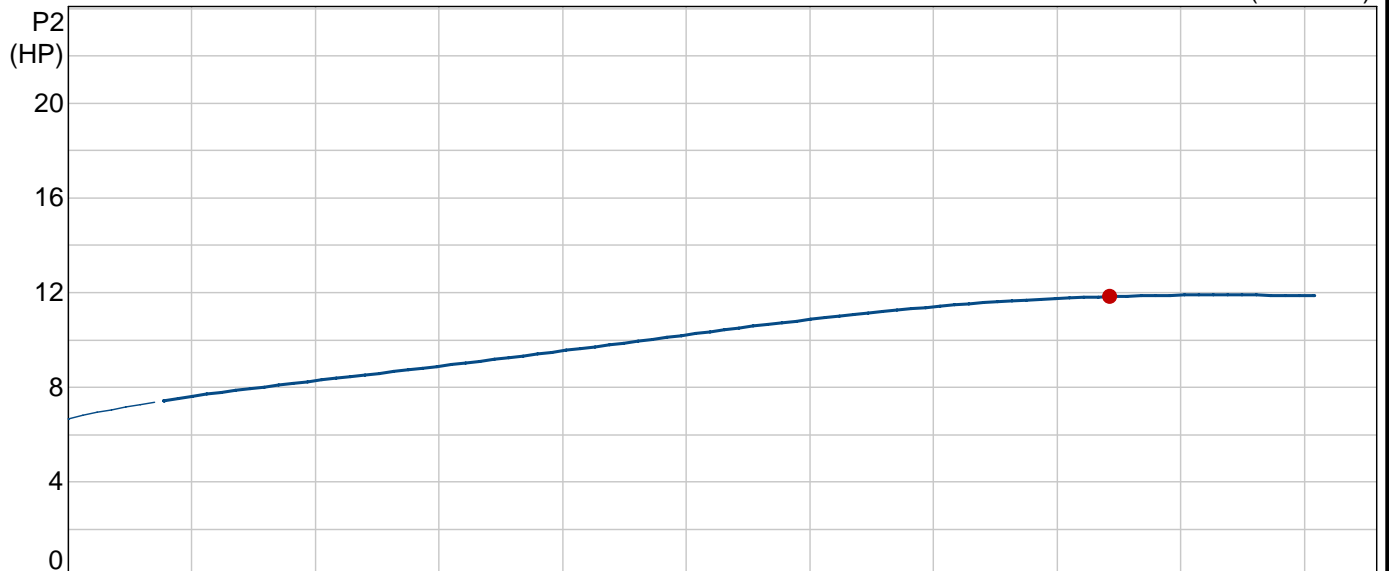
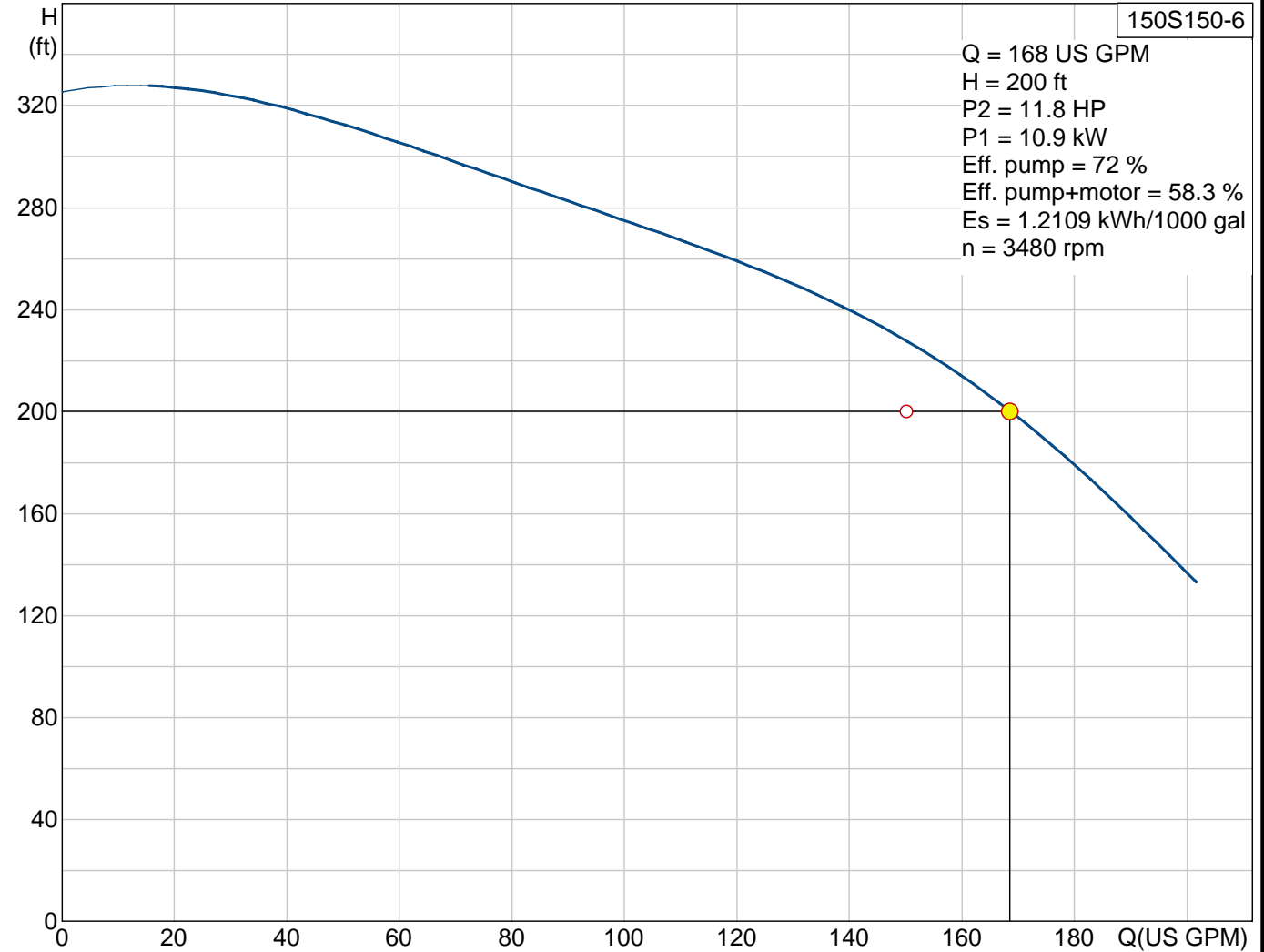



13B73606 150S150-6

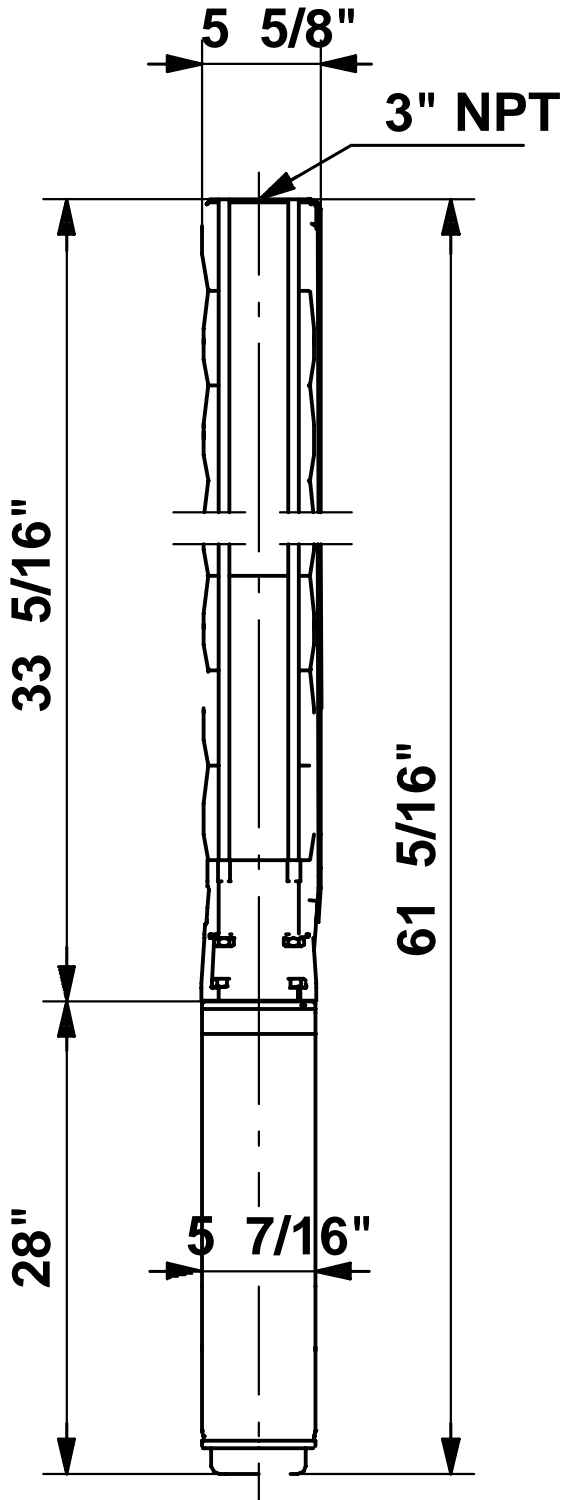

Note! All units are in [mm] unless others are stated.



Company name: Pumps Online, Inc
Created by: David
Phone: (877) 863-5360
Fax: (630) 355-5604
Date: 1/11/2005

13B73606 150S150-6

Input

General

Installation	Well installation, no tank
Flow	150 US GPM
Allowed flow oversize	50 %
Allowed flow undersize	0 %
Capacity selection	Flow
Operating days per year	365 d
Operation hours per day	10 h
Head	200 ft
Pipe system friction losses	0 ft
Include cable in calculation	No
Frequency	60 Hz
Phase	3
Voltage	460 V
Speed regulation	No
Evaluation criterion	Electricity consumption

Configuration

Pump search Standard pump search

Life Cycle Costs

Sizing for Pump B	No
Comparison with	No
Energy price (high)	0.2 \$/kWh
Energy price (medium)	0.12 \$/kWh
Energy price (low)	0.07 \$/kWh
Calculation period	15 years
Inflation rate	3 %
Operation per day (high)	0 h
Operation per day (medium)	0 h
Operation per day (low)	10 h

Sizing result

Type	150S150-6
Quantity * Motor	1 * 15 HP, 460 V
Flow	168 US GPM (+12 %)
H total	200 ft
Power P1	10.9 kW
Power P2	11.8 HP
Current (rated)	23.7 A
Current (actual)	23.7 A
Cos phi (actual)	0.85
Eff. pump	72.0 %
Eff. motor	81.0 %
Eff. total	58.3 % =Eta pump * Eta motor
Flow total	32883650 US gal/year
spec.Consumpt.	1.2108 kWh/1000 gal
	4.63 kWh/gal/ft
Consumption	39810 kWh/Year
Price	\$ 4320
Energy cost	\$ 2787 /Year
Total costs	\$ 57717 /Years

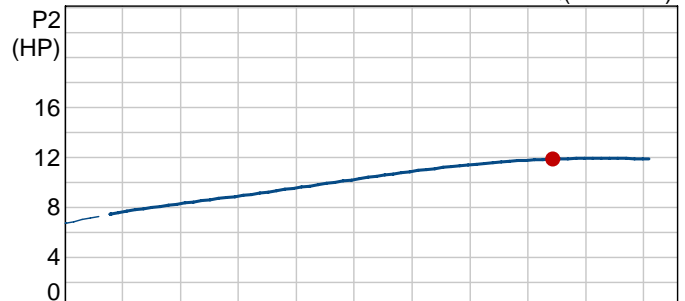
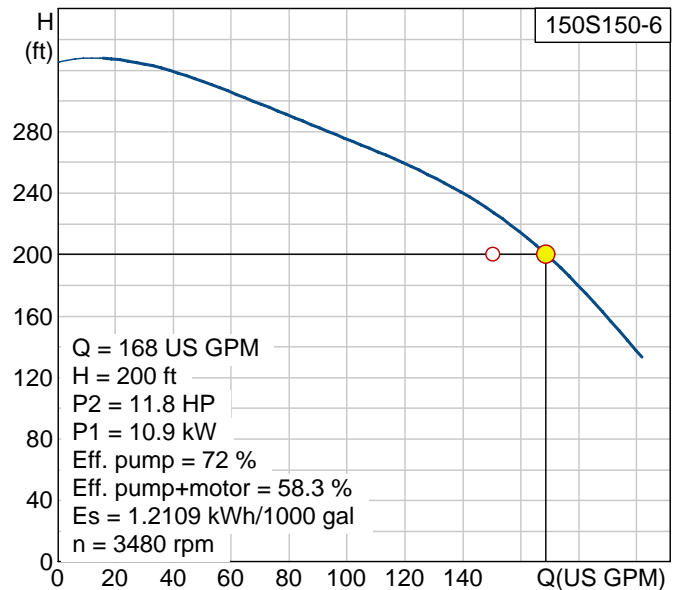

APPENDIX B:

BASELINE SITE INFORMATION SHEET AND OPTIMIZATION EVALUATION REPORT

Note: The attached information sheet was generated during an original nationwide screening effort in 2000 and 2001 and has a different format than the currently used information sheet included in Section 1 of this document.

Hellertown Manufacturing

Bethlehem, PA (Region 3)
CERCLIS ID PAD002390748

Contact Information

RPM Cesar Lee 1650 Arch Street Philadelphia, PA 19103 215-814-3205 (phone) 215-814-3205 (fax) lee.cesar@epa.gov	State Regulator Meg Mustard PADEP 4530 Bath Pike Bethlehem, PA 18017 610-861-2076 (phone) 610-861-2072 (fax) boyer.margaret@dep.state.pa.us	Contractor Jim Romig CDM Federal Corporation 993 Old Eagle School Road, Suite 408 Wayne, PA 19087 610-293-0450 (phone) 610-293-1920 (fax) romigjm@cdm.com
---	--	--

System Information and Data

Type of Fund-lead Site:	EPA-lead	Number of extraction wells:	1
Date original ROD was signed:	9/3/91	Date of construction completion:	9/1996
Date of last modification to ROD:		Date of operational and functional:	3/1996
Type of ROD:	Final	Expected date of turnover to state:	9/2006
Status of P&T system:	Operational	Expected date of completion:	9/2026
Primary goal of system:	Containment & Restoration	Approximate downtime per year:	0 weeks
Presence of NAPLs	Not present	Number of monitoring wells used:	12
Approximate annual O&M costs:	\$350,000	Frequency of sampling:	4 times per year
Costs related to monitoring:	\$150,000	Is plume migration controlled?	Yes
Approximate pumping rate:	50 gpm	Progress of aquifer restoration:	Don't know
Result of previous evaluation of performance/effectiveness:	Evaluated and found not sufficient	Difficulty (due to social/political factors) of implementing minor/major changes:	minor/moderate

Contaminants of Concern:

Benzene
Cis-1,2-dichloroethene
TCE and Vinyl chloride
Trans 1,2-Dichloroethylene
Trichloroethylene (TCE)/Tetrachloroethylene (PCE)

Treatment Processes:

Metals precipitation
Air stripping yes
Biological treatment
UV oxidation
Carbon adsorption yes
Filtration
Ion Exchange
Reverse Osmosis
Off-gas treatment
other/not sure

Comments:

Doug Sutton filled this out based on hand written notes of Cesar Lee.

REMEDIATION SYSTEM EVALUATION

HELLERTOWN MANUFACTURING COMPANY SUPERFUND SITE
HELLERTOWN, PENNSYLVANIA



Report of the Remediation System Evaluation,
Site Visit Conducted at the Hellertown Manufacturing Superfund Site
June 5, 2001

Final Report
November 14, 2001



US Army
Corps of Engineers



US Environmental
Protection Agency

EXECUTIVE SUMMARY

The Hellertown Manufacturing Superfund Site, located in Hellertown, Pennsylvania 1.5 miles south of Bethlehem, Pennsylvania, is approximately 8.6 acres and addresses trichloroethylene (TCE) contamination of the ground water resulting from operations of a former spark-plug manufacturing facility. The initial Remedial Investigation found that the primary sources of contamination are onsite lagoons once used for containing process water laden with chemicals including TCE. The Record of Decision required placement of an asphalt cap covering the former lagoon area and a pump-and-treat system to address the ground water contamination. Construction of the asphalt cap was completed in 1994 and operation of the pump-and-treat system began in February 1996.

Ground water TCE concentrations as sampled during November 2000 are an order of magnitude lower than they were during the Remedial investigation nearly 10 years earlier. In November 2000 TCE concentrations downgradient of the lagoons were as high as 190 ug/L. TCE concentrations upgradient of the lagoons as high as 140 ug/L were also detected in November 2000 suggesting a potentially uncharacterized source on site.

In general, the RSE team found a well-operated system. Recommendations to improve system effectiveness include the following:

- An additional monitoring well downgradient of the site should be installed and sampled to help delineate the plume. Water level measurements from this well would also help in generating a more accurate potentiometric surface downgradient of the extraction well thereby elucidating the extent of the capture zone.
- The ground water extraction system consists of a single well that is currently operating at 110 gpm rather than the designed rate of 160 gpm. A steady decrease from 160 gpm has been noticed since February 2000. Given that this well is solely responsible for containing the plume and extracting contaminated ground water, the well and pump should be evaluated and possibly replaced.
- Institutional controls and deed restrictions are required by the Record of Decision and were mentioned in the five-year review. However, these controls have not yet been implemented. Institutional controls and deed restrictions should be implemented.
- TCE concentrations of 140 ug/L upgradient of the lagoons suggest the possibility of another source area (likely associated with the old equipment washing area or with the old ground water treatment system, which is still in place). An initial investigation using a GeoProbe to collect soil gas and water samples should be conducted to better delineate this contamination.

These recommendations might require approximately \$75,000 in capital costs and might increase annual costs by approximately \$5,000 per year.

Recommendations to reduce life-cycle costs include the following:

- Ground water is extracted at approximately 150 gallons per minute with an approximate concentration of 40 ug/L. This translates to a approximately 30 pounds of TCE extracted and treated per year. Current annual costs for the system total approximately \$130,000 per year (excluding analytical costs). With a capital investment of approximately than \$125,000 this cost could likely be reduced to approximately \$110,000 per year if extracted water is treated only with liquid phase carbon. Furthermore, with this recommendation the treatment system process monitoring could be reduced, potentially saving an additional \$10,000 per year. Thus, with a potential savings of \$30,000 per year, the site managers should consider replacing the current treatment system with liquid phase carbon treatment. However, a pilot test should be conducted prior to implementation to ensure carbon usage is as projected.
- Regardless of revamping the treatment system, the building heat should be reduced. The building is kept at 60 to 65 degrees Fahrenheit but only needs to be as high as 35 or 40 degrees Fahrenheit to protect against freezing. This would save approximately \$1,000 per year in costs for natural gas.

Finally, cleanup limits for the site have yet to be determined. The Record of Decision mentioned that if background levels are lower than the maximum contaminant levels, then background contaminant levels or the detection limit would be the cleanup level. Such cleanup levels would be stricter than those set at the large majority of Superfund sites. The RSE team recommends that the cleanup levels be established so that an exit strategy can be developed.

A summary of recommendations, including estimated costs and/or savings associated with those recommendations, is presented in Section 7.0 of the report.

PREFACE

This report was prepared as part of a project conducted by the United States Environmental Protection Agency (USEPA) Technology Innovation Office (TIO) and Office of Emergency and Remedial Response (OERR). The objective of this project is to conduct Remediation System Evaluations (RSEs) of pump-and-treat systems at Superfund sites that are “Fund-lead” (i.e., financed by USEPA). RSEs are to be conducted for up to two systems in each EPA Region with the exception of Regions 4 and 5, which already had similar evaluations in a pilot project.

The following organizations are implementing this project.

Organization	Key Contact	Contact Information
USEPA Technology Innovation Office (USEPA TIO)	Kathy Yager	11 Technology Drive (ECA/OEME) North Chelmsford, MA 01863 617-918-8362 yager.kathleen@epa.gov
USEPA Office of Emergency and Remedial Response (OERR)	Paul Nadeau	1200 Pennsylvania Avenue, NW Washington, DC 20460 Mail Code 5201G phone: 703-603-8794 fax: 703-603-9112 nadeau.paul@epa.gov
GeoTrans, Inc. (Contractor to USEPA TIO)	Rob Greenwald	GeoTrans, Inc. 2 Paragon Way Freehold, NJ 07728 (732) 409-0344 Fax: (732) 409-3020 rgreenwald@geotransinc.com
Army Corp of Engineers: Hazardous, Toxic, and Radioactive Waste Center of Expertise (USACE HTRW CX)	Dave Becker	12565 W. Center Road Omaha, NE 68144-3869 (402) 697-2655 Fax: (402) 691-2673 dave.j.becker@nwd02.usace.army.mil

The project team is grateful for the help provided by the following EPA Project Liaisons.

Region 1	Darryl Luce and Larry Brill	Region 6	Vincent Malott
Region 2	Diana Cutt	Region 7	Mary Peterson
Region 3	Kathy Davies	Region 8	Armando Saenz and Richard Muza
Region 4	Kay Wischkaemper	Region 9	Herb Levine
Region 5	Dion Novak	Region 10	Bernie Zavala

They were vital in selecting the Fund-lead P&T systems to be evaluated and facilitating communication between the project team and the Remedial Project Managers (RPM's).

TABLE OF CONTENTS

EXECUTIVE	i
PREFACE	iii
TABLE OF CONTENTS	v
1.0 INTRODUCTION	1
1.1 PURPOSE	1
1.2 TEAM COMPOSITION	2
1.3 DOCUMENTS REVIEWED	2
1.4 PERSONS CONTACTED	3
1.5 SITE LOCATION, HISTORY, AND CHARACTERISTICS	3
1.5.1 LOCATION	3
1.5.2 POTENTIAL SOURCES	3
1.5.3 HYDROGEOLOGIC SETTING	4
1.5.4 DESCRIPTION OF GROUND WATER PLUME	4
2.0 SYSTEM DESCRIPTION	6
2.1 SYSTEM OVERVIEW	6
2.2 EXTRACTION SYSTEM	6
2.3 TREATMENT SYSTEM	6
2.4 MONITORING SYSTEM	7
3.0 SYSTEM OBJECTIVES, PERFORMANCE AND CLOSURE CRITERIA	8
3.1 CURRENT SYSTEM OBJECTIVES AND CLOSURE CRITERIA	8
3.2 TREATMENT PLANT OPERATION GOALS	9
3.3 ACTION LEVELS	9
4.0 FINDINGS AND OBSERVATIONS FROM THE RSE SITE VISIT	10
4.1 FINDINGS	10
4.2 SUBSURFACE PERFORMANCE AND RESPONSE	10
4.2.1 WATER LEVELS	10
4.2.2 CAPTURE ZONES	10
4.2.3 CONTAMINANT LEVELS	11
4.3 COMPONENT PERFORMANCE	12
4.3.1 EXTRACTION WELL AND PIPING	12
4.3.2 EQUALIZATION TANK	12
4.3.3 PACKED TOWER	12
4.3.4 AIR COMPRESSORS/BLOWERS	12
4.3.5 CARTRIDGE FILTERS	12
4.3.6 EXTRACTION AND PROCESS PUMPS	12
4.3.7 VAPOR PHASE GRANULAR ACTIVATED CARBON	13
4.3.8 BUILDING AND UTILITIES	13
4.3.9 CONTROLS	13
4.4 COMPONENTS OR PROCESSES THAT ACCOUNT FOR MAJORITY OF MONTHLY COSTS	14
4.4.1 UTILITIES	14
4.4.2 NON-UTILITY CONSUMABLES AND DISPOSAL COSTS	14
4.4.3 LABOR	14
4.4.4 CHEMICAL ANALYSIS	14

4.5	RECURRING PROBLEMS OR ISSUES	15
4.6	REGULATORY COMPLIANCE	15
4.7	TREATMENT PROCESS EXCURSIONS AND UPSETS, ACCIDENTAL CONTAMINANT/REAGENT RELEASES	15
4.8	SAFETY RECORD	15
5.0	EFFECTIVENESS OF THE SYSTEM TO PROTECT HUMAN HEALTH AND THE ENVIRONMENT	16
5.1	GROUND WATER	16
5.2	SURFACE WATER	16
5.3	AIR	16
5.4	SOILS	16
5.5	WETLANDS AND SEDIMENTS	16
6.0	RECOMMENDATIONS	17
6.1	RECOMMENDED STUDIES TO ENSURE EFFECTIVENESS	17
6.1.1	ANALYZE CAPTURE ZONE FOR GROUND WATER EXTRACTION WELL	17
6.1.2	EVALUATE EXTRACTION WELL PRODUCTION	17
6.1.3	IMPLEMENT INSTITUTIONAL CONTROLS	17
6.1.4	EVALUATE OLD PRETREATMENT AREA	18
6.2	RECOMMENDED CHANGES TO REDUCE COSTS	18
6.2.1	CONSIDER MODIFYING TREATMENT PROCESSES TO LIQUID-PHASE CARBON ONLY	18
6.2.2	LOWER BUILDING TEMPERATURE TO LOWER UTILITY COSTS	19
6.3	MODIFICATIONS INTENDED FOR TECHNICAL IMPROVEMENT	20
6.3.1	STOP PERFORMING DATA VALIDATION	20
6.4	MODIFICATIONS INTENDED TO GAIN SITE CLOSE-OUT	20
6.4.1	ESTABLISH CLEANUP GOALS FOR THE AQUIFER	20
6.5	UNUSED EQUIPMENT	20
7.0	SUMMARY	21

List of Tables

Table 3-1.	Maximum Contaminant Level for each Contaminant of Concern
Table 3-2.	Pennsylvania DEP Discharge Criteria for the Hellertown Site
Table 4-1.	TCE Concentrations
Table 7-1.	Cost Summary Table

List of Figures

Figure 1-1	Site layout showing the locations of the monitoring wells and the extraction well
Figure 1-2	Cross section of the geology underlying the Hellertown Manufacturing Superfund Site

1.0 INTRODUCTION

1.1 PURPOSE

In the *OSWER Directive No. 9200.0-33, Transmittal of Final FY00 - FY01 Superfund Reforms Strategy, dated July 7, 2000*, the Office of Solid Waste and Emergency Response outlined a commitment to optimize Fund-lead pump-and-treat systems. To fulfill this commitment, the US Environmental Protection Agency (USEPA) Technology Innovation Office (TIO) and Office of Emergency and Remedial Response (OERR), through a nationwide project, is assisting the ten EPA Regions in evaluating their Fund-lead operating pump-and-treat systems. This nationwide project is a continuation of a demonstration project in which the Fund-lead pump-and-treat systems in Regions 4 and 5 were screened and two sites from each of the two Regions were evaluated. It is also part of a larger effort by TIO to provide USEPA Regions with various means for optimization, including screening tools for identifying sites likely to benefit from optimization and computer modeling optimization tools for pump and treat systems.

This nationwide project identifies all Fund-lead pump-and-treat systems in EPA Regions 1 through 3 and 6 through 10, collects and reports baseline cost and performance data, and evaluates up to two sites per Region. The site evaluations are conducted by EPA-TIO contractors, GeoTrans, Inc. and the United States Army Corps of Engineers (USACE), using a process called a Remediation System Evaluation (RSE), which was developed by USACE. The RSE process is meant to evaluate performance and effectiveness (as required under the NCP, i.e., and "five-year" review), identify cost savings through changes in operation and technology, assure clear and realistic remediation goals and an exit strategy, and verify adequate maintenance of Government owned equipment.

The Hellertown Manufacturing Company Site was chosen based on initial screening of the pump-and-treat systems managed by USEPA Region 3 as well as discussions with the EPA Remedial Project Manager for the site and the Superfund Reform Initiative Project Liaison for that Region. This report provides a brief background on the site and current operations, a summary of the observations made during a site visit, and recommendations for changes and additional studies. The cost impacts of the recommendations are also discussed.

A report on the overall results from the RSEs conducted for this system and other Fund-lead P&T systems throughout the nation will also be prepared and will identify lessons learned and typical costs savings.

1.2 TEAM COMPOSITION

The team conducting the RSE consisted of the following individuals:

Frank Bales, Chemical Engineer, USACE, Kansas City District
Rob Greenwald, Hydrogeologist, GeoTrans, Inc.
Lindsey Lien, Environmental Engineer, USACE HTRW CX
Doug Sutton, Water Resources Engineer, GeoTrans, Inc.

1.3 DOCUMENTS REVIEWED

Author	Date	Title/Description
EPA Region III	September 30, 1991	Record of Decision
Environmental Strategies Corp.	June 17, 1991	Draft Remedial Investigation Report
Ecology and Environment, Inc	August 1994	Hydrogeological Conditions Evaluation
Ecology and Environment, Inc	June 1994	Design Basis Report for Remedial Design Activities
CH2M Hill	June 7, 1996	Construction Report
Roy F. Weston, Inc	October 1998	Design Review Results and Recommendations
EPA Region III	January 27, 1999	Scope of Work
EPA Region III	August 1999	Five Year Review
CDM	November 1999	Draft Operation and Maintenance Plan
CDM	April 2000 through February 2001	Monthly Discharge Monitoring Reports
CDM	March 23, 2001	Annual Operations and Maintenance Report

1.4 PERSONS CONTACTED

The following individuals were present for the site visit:

Frank Bales (USACE) 816-983-3591 francis.e.bales@usace.army.mil
Kathy Davies (USEPA Reg. 3) 215-814-3315 davies.kathy@epa.gov
Rob Greenwald (GeoTrans) 732-409-0344 rgreenwald@geotransinc.com
Cesar Lee (USEPA Reg. 3) 215-814-3205 lee.cesar@epa.gov
Lindsey Lien (USACE) 402-697-2580 lindsey.k.lien@usace.army.mil
Paul Nadeau (USEPA OERR) 703-603-8794 nadeau.paul@epa.gov
Bernice Pasquini (USEPA Reg. 3) 215-814-3326 pasquini.bernice@epa.gov
Jim Romig (CDM Federal) 610-293-0450 romigjm@cdm.com
Mindi Snoparsky (USEPA Reg. 3) 215-814-3316 snoparsky.mindi@epa.gov
Doug Sutton (GeoTrans) 732-409-0344 dsutton@geotransinc.com

1.5 SITE LOCATION, HISTORY, AND CHARACTERISTICS

1.5.1 LOCATION

The Hellertown Manufacturing Superfund Site is approximately 8.6 acres and is located on Main Street (Route 412) in Hellertown, Borough, Northampton County, Pennsylvania. The remedy at the site addresses contamination from the manufacturing of spark plugs which began at that location in 1918 and was discontinued in 1982. The surrounding area is a combined residential and commercial area approximately 1.5 miles south of Bethlehem, Pennsylvania. The site is bordered on the north by Interstate 78, on the east by Main Street, on the south by private residences, and on the west by a Conrail railyard. Saucon Creek is located on the far west side of the railroad property approximately 600 feet from the western boundary of the site. The site layout is depicted in Figure 1-1.

The warehouse onsite was purchased by Paikes Enterprises, Inc. in 1988 and used as a warehouse. The current property owner is Federal Mogul.

1.5.2 POTENTIAL SOURCES

During operations at the spark-plug plant from 1930 to 1976, five unlined discharge lagoons were maintained to treat aqueous discharges. Discharges consisted of various chemicals including sodium and potassium nitrates and nitrites, alkaline wastes, cyanide, zinc, hexavalent chromium, and trichloroethylene. In 1965 a wastewater treatment plant was added to the facility. In 1971 this plant was upgraded by installing sludge drying beds, and in 1976, the lagoons were backfilled. A Remedial Investigation was conducted from 1988 to 1991 to investigate the extent of contamination site. The investigation did find soil and ground water contamination associated with the lagoons, especially lagoon #4, but did not find significant contamination associated with underground storage tanks or an equipment wash area also located at the site. The Remedial investigation was followed by a Record of Decision on September 30, 1991 specifying an asphalt cap, institutional controls, and a pump-and-treat system. The asphalt cap covering the former lagoon area was completed in 1994. Elements of the wastewater treatment system and the sludge drying beds were left in place.

It is believed that contaminants including TCE infiltrated through the unlined lagoons into the aquifer. The lagoons were dredged and backfilled, and soil samples indicated volatile organic compounds (VOCs) at levels less than 1 mg/kg, with the highest concentrations found near lagoon 4 in the northwest corner of the site. The monitoring wells show that VOCs have been transported offsite in ground water toward Saucon Creek at levels that exceed MCLs. In contrast to the findings of the Remedial Investigation, it appears that the elements of the old wastewater treatment system or equipment wash area may have been a potential source of TCE, because an overburden well approximately 100 feet downgradient of those features (CSP-7) had a TCE concentration of 140 ug/L in November 2000. That well is located upgradient of the lagoons, which have historically been interpreted as the primary source of ground water impacts.

1.5.3 HYDROGEOLOGIC SETTING

Figure 1-2, taken from the Hydrogeological Conditions Evaluation, depicts the geologic units observed at the site. This figure depicts a northwest-southeast cross section of the stratigraphic units and the monitoring and extraction well locations. The site elevation ranges from approximately 320 feet above mean sea level (MSL) in the east to approximately 280 feet MSL in the west. Beneath the asphalt cap installed in 1994, the stratigraphy includes 10 feet of overburden and 30 feet of saprolite and phyllitic schist overlaying fractured dolostone identified with the Tomstown formation. A sandstone layer 10 feet thick exists within the dolostone formation at a depth ranging from 80 to 100 feet below ground surface (bgs).

Two permanent zones of saturation are of concern at the site: an intermediate zone, existing 15 to 95 feet bgs occurring primarily in the weathered saprolite; and a deep zone, existing approximately 95 to greater than 215 feet bgs occurring in the dolostone which is fractured and exhibits characteristics of solution weathering and channelized flow. The saprolite acts as a semiconfining layer above the deeper fractured and weathered zone. In both zones, water flows to the west-northwest toward Saucon Creek although the Hydrogeological Conditions Evaluation suggests the presence of significant vertical gradients responsible for transporting TCE to deeper elevations 295 feet bgs as detected in CSP-24. Flow in the deep zone may continue beyond Saucon Creek before rising and returning to discharge into the creek.

1.5.4 DESCRIPTION OF GROUND WATER PLUME

The plume consists primarily of TCE and *cis*-1,2 dichloroethylene, a degradation product of TCE. The highest TCE concentration as measured during the November 2000 sampling event is 190 ug/L and was measured in a sampled taken from monitoring well CSP-14, a shallow monitoring well located immediately downgradient of the northwest corner of the site (specifically downgradient of lagoon #4). Other shallow wells in the same area measured during the same sampling event have concentrations of 150 ug/L, 80 ug/L, and 33 ug/L. A deep monitoring well located adjacent to these wells but over 100 feet deeper had a concentration of 43 ug/L. A single monitoring well screening the overburden, CSP-7, which is located 100 feet downgradient of the old wastewater treatment plant (upgradient of the lagoons), had a concentration of 140 ug/L in November 2000. Another monitoring well screening the shallow bedrock, CSP-10, also located upgradient of the lagoons, had a TCE concentration of 27 ug/L and a DCE concentration of 42. The impacts at CSP-7 and CSP-10 suggest that at least a portion of the plume formed upgradient of the waste lagoons.

TCE contamination in ground water has migrated beyond the site boundary. Unfortunately, there are no monitoring wells between the wells near immediate site boundary and the wells near Saucon Creek. Therefore, it is difficult to characterize the plume in that region, which is immediately downgradient of the remediation well. Low concentrations in ground water have historically been found in the overburden along the eastern bank of Saucon Creek. For instance, CSP-16 has had TCE as high as 6.3 ug/l in 1999, although all other readings since 1996 have been below 5 ug/l at that well. CSP-18, a shallow ground water well near Saucon Creek, had TCE of approximately 50 ug/L in 1990 and 1993, but all samples there have been “non-detect” since 1996. It should also be noted that there are no wells near Saucon Creek immediately downgradient of well CSP-14, where highest ground water concentrations are observed. TCE has also been infrequently detected at very low concentrations (2 ug/l or less) in the deep ground water zone, more than 1,000 feet to the west of Saucon Creek (i.e., on the other side). It is not clear that those impacts are related to this site.

2.0 SYSTEM DESCRIPTION

2.1 SYSTEM OVERVIEW

The remedy for the Hellertown Manufacturing Site specified in the ROD includes the following items:

- placement of an impermeable cover over the entire former lagoon area;
- surface water runoff controls;
- ground water extraction from one well located on-site, above-ground treatment (air stripping and cartridge filtration), and discharge to Saucon Creek;
- long term ground water monitoring; and
- deed restrictions.

The site was covered with asphalt in December 1994, and construction completion of the ground water extraction well and treatment plant occurred in January 1996 with full time operation beginning in February 1996. The plant was down for a period of 17 months while a new well was installed to replace the original extraction well.

2.2 EXTRACTION SYSTEM

The extraction system consists of one well, EW-1. Originally installed in 1993 in the location of former lagoon 4, EW-1 originally had a screened interval from 115.5 to 215.5 feet bgs (163 to 63 feet MSL). Although the well was designed to pump 160 gallons per minute (gpm), it only yielded 90 gpm. The well was replaced by a new well in 1998-1999, EW-1R, in the same approximate location with a screened interval ranging from 84 to 219 feet bgs (199 to 63 feet MSL). The new well and pump are designed to extract 160 gallons per minute (gpm), and although the well was operated at approximately 160 gpm for a while, it was observed in February 2000 to be cavitating at 160 gpm, and flow rate has been periodically decreased in 10 gpm increments since then to the current rate of approximately 110 gpm.

2.3 TREATMENT SYSTEM

According to the construction report(CH2MHILL, 1996) the ground water treatment system was designed with a treatment capacity of 100 gpm, an influent concentration of 970 ug/L (or parts per billion by mass), and an effluent concentration of 1 ug/L. However, it was stated many times during the RSE site visit that the wells were designed to extract at 160 gpm, and the system is certainly sized to handle at least that flow rate. The system consists of the following elements:

- equalization tank,
- cartridge filters,
- air stripping tower,
- vapor phase granular activated carbon (GAC),
- and discharge piping to Saucon Creek.

The entire system is contained in a building heated by two boilers (which are also used to heat the influent into the vapor phase GAC), and the interior piping for the water is insulated. The system allows remote operation. An operator/maintenance engineer visits the site twice each month, and an auto dialer calls the plant engineer when the system shuts down. The plant cannot be restarted remotely.

2.4 MONITORING SYSTEM

The monitoring system consists of 30 ground water monitoring wells, a portion of which are sampled on a quarterly basis. The November 2000 sampling event involved VOC analysis from four overburden wells, 19 shallow wells, and four deep wells. In addition, semi-annually the surface water and sediments from Saucon Creek are measured and the ground water elevations from all 30 monitoring wells and the extraction well are measured.

Plant influent and effluent are measured twice per month and air influent and effluent for the air stripper is sampled once every two months with a photo-ionization detector.

3.0 SYSTEM OBJECTIVES, PERFORMANCE AND CLOSURE CRITERIA

3.1 CURRENT SYSTEM OBJECTIVES AND CLOSURE CRITERIA

The goal as specified in the ROD is to restore the aquifer to either the maximum contaminant levels (MCLs), which are listed in Table 3-1, or applicable State background concentrations, whichever is more stringent. These State background levels were to be determined by sampling subsequent to the ROD and before treatment began. If the contaminants of concern were not detected in background samples, the detection limits are to be used as the cleanup levels. The 5-year review authored in 1999 states that EPA has not yet determined background concentrations, and that “upon determining the background concentrations...EPA, in accordance with the ROD, will determine the remediation goal for this site”. These cleanup goals have not yet been formally stated in the site documents reviewed by the RSE team. Along with the MCLs, the detection limits for contaminants are provided in Table 3-1. The discharge criteria to Saucon Creek listed in Table 3-2.

Table 3-1: Maximum Contaminant Level for each Contaminant of Concern

Contaminant	MCL (ug/L)	Detection Limit (ug/L)	Analytical Method
Benzene	5	0.20	601/602
Tetrachloroethylene	5	0.03	601/602
Trichloroethylene	5	0.12	601/602
Vinyl chloride	2	0.18	601/602
trans-1,2 Dichloroethylene	100	0.10	601/602
cis-1,2 Dichloroethylene	70	0.12	524.2

Table 3-2: Pennsylvania DEP Discharge Criteria for the Hellertown Site

Effluent Parameter	Average Monthly Conc. (ug/L)	Average Daily Conc. (ug/L)	Instantaneous Maximum Concentration (ug/L)	Measurement Frequency	Sample Type
Benzene	1	2	2.5	2/month	Grab
Total BTEX*	100	200	250	2/month	Grab
Tetrachloroethylene	1	2	2.5	2/month	Grab
Trichloroethylene	1	2	2.5	2/month	Grab
Vinyl chloride	1	2	2.5	2/month	Grab
trans 1,2 DCE	1	2	2.5	2/month	Grab
cis 1,2 DCE	1	2	2.5	2/month	Grab

*all concentrations in microgram per liter (ug/l)

3.2 TREATMENT PLANT OPERATION GOALS

The operational goal of the plant is to maintain effluent TCE concentrations below 1 ug/L, which agrees with the design specifications of the plant and complies with the discharge permit for that contaminant.

3.3 ACTION LEVELS

The action levels regarding plant discharge are noted above. The five-year review states that cleanup goals have not been established for this site.

4.0 FINDINGS AND OBSERVATIONS FROM THE RSE SITE VISIT

4.1 FINDINGS

The RSE team noted that the system is well maintained and not operated at an unusual cost. The observations and recommendations given below are not intended to imply a deficiency in the work of either the designers or operators, but are offered as constructive suggestions in the best interest of the EPA and the public. These recommendations obviously have the benefit of the operational data unavailable to the original designers.

4.2 SUBSURFACE PERFORMANCE AND RESPONSE

4.2.1 WATER LEVELS

The water levels in the monitoring wells are regularly monitored. Water levels have been plotted by CDM (e.g., CDM, 2000 Annual O&M Report) on line graphs to compare pre-pumping and post-pumping water levels, to assess whether drawdown occurs due to pumping. The overburden wells show little if any drawdown due to pumping. Many shallow bedrock wells show some drawdown due to pumping, and those wells are typically near the extraction well (e.g., wells CSP-5A, CSP-5B, CSP-6, CSP-12, CSP-13, CSP-14), while some are further away from the extraction well (CSP-11, CSP-15, CSP-18). Shallow bedrock wells distant from the extraction well typically show little or no drawdown associated with extraction, as expected. The three deep bedrock wells closest to the extraction well also show drawdown due to pumping (CSP-5c, CSP-24, CSP-25). Deep bedrock wells distant from the extraction well typically show little or no drawdown associated with extraction, as expected.

Analysis of water level data from October 1997 when pumping was not occurring reveals information about vertical hydraulic gradients in the absence of pumping. Water levels from CSP-5A, CSP-5B, and CSP-5C, which are located adjacent to each other and are vertically spaced 10 feet apart, demonstrate an upward gradient in the absence of pumping. Likewise, CSP-6 and CSP-25, which are also adjacent but separated vertically by 100 feet also suggest an upward gradient in the absence of pumping.

4.2.2 CAPTURE ZONES

Although the water level analysis suggests that drawdown does occur due to pumping, that observation does not define the capture zone of the extraction well. Capture zones are based on hydraulic gradients, which are impacted not only by drawdown due to pumping, but also by background hydraulic gradients. A capture zone was interpreted from water level data collected during the pumping test at the original extraction well (Ecology and Environment, 1994) that suggested the capture zone would encompass the majority of the area associated with the former lagoons and possibly the contamination associated with CSP-7. This former capture zone analysis did suggest that

contamination in the area of wells CSP-10 and CSP-11 likely would not be captured. A more recent interpretation of potentiometric surface was not evident in documents reviewed by the RSE team.

The November 2000 water levels provide sufficient information from the shallow bedrock wells to suggest that ground water in the shallow bedrock near wells CSP-12, CSP-13, CSP-14, and CSP-5A is captured by the extraction well. Data is too sparse to estimate ground water directions and capture in the overburden and the deep bedrock or in the shallow bedrock further from the extraction well. Because no monitoring wells or water-level measurements exist for over 400 feet to the west (downgradient) the extent of contamination and capture is unknown downgradient of CSP-12, CSP-13, CSP-14, and CSP-5A.

4.2.3 CONTAMINANT LEVELS

Ground water concentrations appear to be declining slightly at some wells, although TCE concentration at many wells are still significantly higher than the MCL of 5 ug/l. It is significant to note that current influent levels to the plant (30-40 ug/l) are significantly lower than the design influent concentration of nearly 1,000 ug/l.

Table 4-1 presents TCE concentrations versus time at selected wells.

Table 4-1 TCE Concentrations

Date	EW-1R (extraction)	CSP-14 (shallow)	CSP-25 (deep)	CSP-6 (shallow)	CSP-13 (shallow)	CSP-12 (shallow)	CSP-7 (overburden)
1990	not constructed	420	not analyzed	310	700	390	180
1993	not constructed	220	310	350	150	110	240
Dec 1995	not available	199	152	226	184	149	141
Dec 1996	not available	180	94	120	170	200	90
Dec 1999	41.5 (avg)	192	60	59	220	45	99
Nov 2000	26	190	43	80	150	33	140

Note that TCE impacts are observed in all three zones (overburden, shallow bedrock, and deep bedrock).

As stated in Section 1.5.4, there are no monitoring wells between the wells near the immediate site boundary and the wells near Saucon Creek. Therefore, it is difficult to characterize the plume in that region, which is immediately downgradient of the remediation well. It should also be noted that there are no wells near Saucon Creek immediately downgradient of well CSP-14, where highest ground water concentrations are observed. Concentrations at well CSP-18, a shallow bedrock well near Saucon Creek, had TCE at approximately 50 ug/l in 1990 and 1993, but has been “non-detect” since 1996.

4.3 COMPONENT PERFORMANCE

During the first two years of operation the plant had difficulties in meeting extraction flowrate and discharge standards. These items were addressed by Weston in 1998 by replacing the extraction well, upgrading some system components (pumps, distributor plate in air stripping tower) and redoing control logic for the plant.

4.3.1 EXTRACTION WELL AND PIPING

Since being replaced in 1998, the extraction well has performed well. However, the flow rate has been declining since February 2000, from 160 gpm to the current rate of approximately 110 gpm. The pump is "hard-piped" with steel which requires heavy machinery to remove the pump. Therefore, it has not been pulled to check it with respect to deterioration. The pump from the original well was available for inspection, and showed evidence of significant corrosion (pits, holes, slits, rust).

4.3.2 EQUALIZATION TANK

The 3,000-gallon equalization tank provides capacity for only fifteen minutes of storage. The flow rate out of the tank is controlled by the pump that forces water to the top of the air stripper. The plant runs continuously, not in batch mode.

4.3.3 PACKED TOWER

The packed tower is 35 feet high with a packed bed depth of 24 feet. The water is distributed evenly across the packing with a distribution plate. The packing is jaeger plastic two inch Tri-packs. No corrosion or scaling problems have been identified.

4.3.4 BLOWER

One blower is utilized to provide forced air to the stripping tower. This unit is 7.5 hp and provides process air at approximately 1,000 cfm.

4.3.5 CARTRIDGE FILTERS

Two parallel cartridge filters remove solids prior to entering the air stripping tower. The relatively clean and soft water at the site does not foul these filters. The operators have changed these filters only once since they took over operation in 1999 and noted that they showed little sign of being fouled.

4.3.6 EXTRACTION AND PROCESS PUMPS

The pumps include a well pump (15 hp) and a process pump (7.5 hp) inside the building. Both pumps have been upgraded since 1998 renovations were performed. The process pump has not shown excessive wear. The pumping rate of the well pump, however, has declined from 160 gpm at installation to 110 gpm at the time of the RSE— a decrease of 10 gpm in the pumping rate occurs every 5 to 6 months. This is due to oscillations in the pumping rate and shaking in the piping that the operator addresses by throttling back a valve to decrease the extraction rate by 10 gpm.

4.3.7 VAPOR PHASE GRANULAR ACTIVATED CARBON

Two vapor GAC units are on site. The process air from the air stripper is heated to lower the relative humidity and therefore increase carbon capacity. The units each contain approximately 2,000 pounds of activated carbon. Because influent concentrations to the plant are lower than originally designed, carbon changeout should be very infrequent. A simple calculation is provided below:

Calculate of pounds of TCE per year in extracted ground water and assume 100% removal by air stripper.

$$\frac{150 \text{ gallons}}{\text{minute}} \times \frac{40 \text{ ug}}{\text{liter}} \times \frac{3.785 \text{ liters}}{\text{gallon}} \times \frac{10^{-9} \text{ kg}}{\text{ug}} \times \frac{2.2 \text{ lbs}}{\text{kg}} \times \frac{1440 \text{ minutes}}{\text{day}} \times \frac{365 \text{ days}}{\text{year}} = \frac{26 \text{ lbs}}{\text{year}}$$

Calculate pounds of vapor phase carbon per year:

$$\frac{5 \text{ lbs of carbon}}{\text{lb of contaminant}} \times \frac{26 \text{ lbs of contaminant}}{\text{year}} = \frac{130 \text{ lbs of carbon}}{\text{year}}$$

Due to the low organic loading to the plant the lead unit should not require new carbon for 10 to 15 years.

4.3.8 BUILDING AND UTILITIES

The building encases the entire process including the air stripping tower. The temperature in the winter is maintained at 60 to 65 degrees Fahrenheit. The heat for the building and for the preheater (for vapors prior to GAC unit) are provided by two separate boilers. The operators are going to begin a long term maintenance contract for upkeep and tuning of these units.

4.3.9 CONTROLS

The extraction well and plant are shut down for alarms including but not limited to low levels in the extraction well, leaking in the piping, high water levels in the air stripper reservoir, low air through the air stripper, or a high level in the building sump. The controls also allow for partial shutdown. The extraction well is shutdown when a high level is detected in the equalization tank and the feed pump is shutdown when a low level is detected in the equalization tank. The blower for the air stripper shuts down if either of these signals last for longer than 30 minutes. Each alarm triggers an autodialer that contacts the project engineer.

4.4 COMPONENTS OR PROCESSES THAT ACCOUNT FOR MAJORITY OF MONTHLY COSTS

The total annual cost of operations is estimated at \$132,500 excluding analytical costs. The annual cost breakdown included labor (including project management) at \$93,000, travel costs of \$6,500, direct costs (utilities and materials for sampling) of \$33,000. Laboratory analyses and data validation are

performed under the Contract Laboratory Program (CLP), and costs are not directly assigned to the site and therefore not included in the annual cost estimate provided above.

It should be noted that during the information survey conducted prior to the RSE, the estimated costs for this site were \$350,000 per year. That number is also referred to in the 5-year review. Reportedly the estimate of \$350,000 per year has been used for the purpose of insuring that adequate budget is available as a contingency because of maintenance issues in past years that have required significant expenditure.

4.4.1 UTILITIES

Of the \$33,000 spent on direct costs, approximately \$15,000 is spent on electricity for running the pumps and \$5,000 is spent on natural gas for heating the building and the air entering the vapor GAC.

4.4.2 NON-UTILITY CONSUMABLES AND DISPOSAL COSTS

The remainder of the direct costs are primarily spent on materials needed for the process monitoring and quarterly sampling events. There are no disposal costs that occur on a regular basis. A reserve of filter cartridges is available onsite, and because these filters infrequently require replace, additional filters will not need to be purchased for a number of years.

4.4.3 LABOR

Labor, including project management, accounts for 70% of the system costs. The system is maintained on a regular schedule by a subcontracted operator who is present at the site once every two months. In addition, process influent and effluent are sampled twice per month by the O&M contractor. An operations and maintenance inspection along with sampling of the plant influent and effluent are conducted by the project manager twice per month, and aquifer sampling and water level measurements are conducted quarterly.

4.4.4 CHEMICAL ANALYSIS

The chemical analyses (for VOC's) performed are in accordance with the surface water discharge requirements from the State. It should be noted that this data is being validated which is not a standard procedure for long term monitoring at pump and treat sites. As stated earlier, analyses are performed under the CLP program, and those costs are not directly assigned to the site.

4.5 RECURRING PROBLEMS OR ISSUES

The most notable recurring problem is the decreasing flow from the extraction well. No notable process problems have occurred. Unscheduled shutdowns have all been weather related. The boilers have required excessive maintenance; therefore, the site is going to enter a boiler maintenance contract to relieve this problem.

4.6 REGULATORY COMPLIANCE

Compliance with discharge standards was a problem early during operation of the plant. Upon completion of upgrading the extraction well pump, process controls, process pump and distribution system in the tower, the treated ground water has met all discharge criteria.

4.7 TREATMENT PROCESS EXCURSIONS AND UPSETS, ACCIDENTAL CONTAMINANT/REAGENT RELEASES

The system has been shut down on several occasions. These shutdowns have almost exclusively been caused by power outages rather than any process problems.

4.8 SAFETY RECORD

No safety issues were apparent and no safety problems or accidents were reported to have occurred in the past. There is a broken fence that was reported in the ROD, and the fence was still found to be broken during the RSE visit.

5.0 EFFECTIVENESS OF THE SYSTEM TO PROTECT HUMAN HEALTH AND THE ENVIRONMENT

5.1 GROUND WATER

Several monitor wells and piezometers are located on site. Some wells have shown marked decline in site contaminants while others have shown little to no decrease in concentrations. It is not clear that the source of contamination near CSP-7 of CSP-10 (upgradient of the lagoons) has been characterized. The capture zone of the extraction well has not been documented since extraction began, and while there are monitoring wells near Saucon Creek, there are no monitoring wells immediately downgradient of the most contaminated well (CSP-14) all the way to Saucon Creek.

5.2 SURFACE WATER

Surface water in the creek is sampled upstream and downstream of the outfall twice per year. No significant impacts have been observed. TCE was detected at a very small concentration (estimated at 1 ppb) in one surface water sample in July 2000.

5.3 AIR

Air emissions from the GAC units are sampled two times per month using a PID. The loading to the carbon units is minimal, and not likely to be any problem.

5.4 SOILS

Soils exposure was remedied by the asphalt cover that now covers the former lagoons and serves as a parking lot.

5.5 WETLANDS AND SEDIMENTS

The sediments in the creek are sampled at several points up and downstream of the outfall twice per year. Reportedly, minor detections of VOC's in sediments of Saucon Creek have been detected both upgradient and downgradient of the treatment plant outfall.

6.0 RECOMMENDATIONS

6.1 RECOMMENDED STUDIES TO ENSURE EFFECTIVENESS

6.1.1 ANALYZE CAPTURE ZONE FOR GROUND WATER EXTRACTION WELL

As stated in the five year review, the capture zone (EW-1R) needs to be further evaluated to determine if EW-1R is containing the entire plume as designed. This should include development of potentiometric surface maps with water levels indicated and interpreted capture zone superimposed. A one-time effort of \$5,000 is appropriate, plus an additional \$3,000 per year thereafter for continued capture zone evaluation on the basis of potentiometric surface maps.

Ideally, one or more monitoring wells in the shallow bedrock should be added between CSP-14 and Saucon Creek, to allow increased resolution for water level evaluation as well as water quality evaluation. The ability to add one or more wells in that area may be hampered by access issues, as well as limitations due to steep slopes immediately west of CSP-14. To add one well should cost approximately \$20,000 in capital costs, and additional sampling and analysis of that well will be less than \$2,000 per year.

6.1.2 EVALUATE EXTRACTION WELL PRODUCTION

The decrease in flow from the extraction well is a concern because it could adversely impact the ability to maintain hydraulic control. Therefore, the pump should be removed and the pump and well should be evaluated (although removing the pump is a difficult operation, it will need to be done). It is suspected that this pump and screen are failing as did the previous extraction well. It may be necessary to also evaluate the screen with a downhole camera while the pump is removed. Chemical analysis of the water will help identify the potential agents for fouling or corrosion. Sampling should be conducted from the extraction well for iron, manganese, sulfur minerals and complexes, pH, conductivity, sand/silt content, carbon dioxide, carbonate, bicarbonate, and major ions including calcium and magnesium. The cost for analyzing all of these constituents in a single sample should be approximately \$200 per sample. Cost for these combined evaluations should be less than \$10,000. The RSE team has not estimated cost for a replacement pump and/or replacement well.

6.1.3 IMPLEMENT INSTITUTIONAL CONTROLS

As required by the ROD and noted in the five year review, institutional controls are to be implemented to prohibit the use of site ground water for a drinking water or a domestic well. Currently, this has not been performed. Estimated cost for this activity is \$15,000.

6.1.4 EVALUATE OLD PRETREATMENT AREA

Contamination in CSP-7 and possibly in CSP-10 needs to be further evaluated. The original Remedial Investigation analyzed soil contamination near the CSP-7 and these samples showed low concentrations of total VOCs around 50 ug/kg. That investigation, however, did not thoroughly

evaluate ground water contamination. Current measurements of VOCs in the soil gas and ground water will help to more thoroughly evaluate and delineate contamination in this area. The soil gas evaluations would also be useful for evaluating whether or not soil gas concentrations are elevated across the southern site boundary, in the vicinity of the frame dwelling. Because ground water is present above the bedrock, a GeoProbe could be used to obtain soil gas and ground water grab samples in approximately 15 locations primarily around the former equipment washing area and waste water treatment facility. This evaluation, including hiring out a GeoProbe for two or three days and conducting the analytical work could be accomplished for approximately \$15,000. Additional investigation would be based on results of those studies.

Given the location of present monitoring wells, it will be very difficult to determine if CSP-7 and the surrounding plume in that vicinity are captured by the current extraction well. The importance of that uncertainty will be more meaningfully evaluated after the extent of contamination in the vicinity of CSP-7 and the old water treatment area is better understood, as per the recommendation described above.

6.2 RECOMMENDED CHANGES TO REDUCE COSTS

6.2.1 CONSIDER MODIFYING TREATMENT PROCESSES TO LIQUID-PHASE CARBON ONLY

As discussed in Section 4.3.7, based on a pumping rate of 150 gpm and influent concentration of 40 ug/l, there is less than 30 lbs of TCE removed each year from the ground water. The design influent concentration was much higher (nearly 1,000 ug/l). It could be argued that the water extracted from EW-1R could simply be discharged directly to the creek through the existing outfall. By the time that water discharged to the creek, most of the TCE would have volatilized, and certainly after discharge to the surface water the rest would volatilize. However, EPA and the Pennsylvania Department of Environmental Protection generally prefer remedies that reduce mass rather than transfer mass into the atmosphere. Therefore, a more palatable option would be to replace the current filter/air stripper/vapor carbon system with a filter/liquid-phase carbon system. Given that the filters do not appear to be removing significant amounts of solids, clogging of the filters or carbon should not be significant a problem.

Using a conservative estimate of 300 lbs of liquid phase carbon to one pound of contaminant the remedy would require 9,000 lbs of carbon per year. At \$2/lb, this would equate to \$18,000 per year of carbon. Two GAC units each containing 10,000 lbs of carbon and aligned in series would provide over 15 minutes of contact time in each vessel, and the lead vessel would have enough carbon treat the water for a year. Water could be sampled after the primary unit to help determine when it needs replacement and after the secondary unit to determine if the effluent concentration is below the discharge criteria. Due to chemical loading and potential fouling, the lead unit may require replacement once a year. During this replacement, the secondary unit would become the primary unit, and the replacement vessel would become the secondary unit.

The air stripper and the current vapor phase carbon units could be removed and the new liquid phase carbon units could be plumbed into the current system after the cartridge filters. To avoid the costs of heating the entire treatment plant, a small insulated room with a small electric heater could be constructed within the current treatment building to house the cartridge filters and the new carbon

units. The heater would keep the small room at 50 degrees Fahrenheit during the winter thereby discontinuing the need for the boilers that are currently used.

Under this scenario less labor and power would be required. Although the electric heater would require additional electricity; overall, the electricity would be reduced because the 7.5 hp blower to the air stripper could be removed. The boilers and the natural gas would be eliminated. The visits by the subcontracted operator once every two months could be eliminated and project management associated with the subcontract and general maintenance issues could be reduced. In addition, because of the simplicity of the system, someone locally could be hired to conduct site visits twice per month and sampling of the process water.

It is estimated that these changes might require up to \$125,000 to implement, but net savings in labor, travel, and utilities costs could be \$22,000 per year or more. Also, the proposed maintenance contract for the boilers could be eliminated thus removing an expected additional cost.

With two 10,000-lb carbon units in series treating approximately 30 lbs of contaminants per year (requiring a conservative estimate of 9,000 lbs of carbon per year), it is reasonable to reduce the frequency of site visits and process monitoring. Because the second carbon unit serves as a natural backup to the first, a site visit that includes sampling of the process water once every month would likely be sufficient. If over time it is found that the carbon vessels are replaced less frequently than once per year, site visits and sampling of the process water could be reduced to once every two months. If site visits and sampling of the process water is reduced to once per month, and these visits are made by a local contractor, an additional savings of approximately \$10,000 per year could be expected.

A comparison of the capital costs and the annual cost savings associated with this recommendation suggests that life cycle savings would be realized after approximately 6 years of operation. Therefore, to realize substantial costs savings, this recommendation should only be implemented if system operation is expected to continue for 10 or more years.

Prior to implementation, a pilot test with 55 gallon drums of carbon could be conducted with a fraction of the current extracted water (i.e., 11 gpm) to verify that actual carbon usage is similar to that estimated in this recommendation.

6.2.2 LOWER BUILDING TEMPERATURE TO LOWER UTILITY COSTS

Under current operations, the building temperature is maintained at 60 to 65 degrees during the winter months even though the building is only manned a few days per month. If the current treatment process is continued, the air stripping towers can operate at subfreezing temperatures. Therefore, it is recommended that building temperature be maintained around 35 to 40 degrees Fahrenheit. This might reduce heating costs by \$1,000 year.

6.3 MODIFICATIONS INTENDED FOR TECHNICAL IMPROVEMENT

6.3.1 STOP PERFORMING DATA VALIDATION

The need to validate the monitoring data should be revisited as this step is typically only required for site investigation and not for operation. This reduction in scope will save a nominal amount of money (apparently these costs are not directly assigned to the site) and will allow quicker use of the collected data.

6.4 MODIFICATIONS INTENDED TO GAIN SITE CLOSE-OUT

6.4.1 ESTABLISH CLEANUP GOALS FOR THE AQUIFER

The ROD states that cleanup goals will be the more stringent of the Federal MCLs or the background concentration established by the State. These cleanup goals have not been formally established. These goals should be established so that the closure criteria are clear and an appropriate exit strategy can be developed.

6.5 UNUSED EQUIPMENT

No unused equipment was noticed at this site. If recommendations in Section 6.2.1 are implemented, there may be some unused government equipment (filters, blower, pump, etc.).

7.0 SUMMARY

In general, the RSE team found a smoothly running treatment system and a well-operated and maintained site. The observations and recommendations mentioned are not intended to imply a deficiency in the work of either the designers or operators but are offered as constructive suggestions in the best interest of the EPA and the public. These recommendations have the obvious benefit of the operational data unavailable to the original designers.

Several recommendations are made to assure system effectiveness, reduce future operations and maintenance costs, improve technical operation, and gain site close out. The recommendations to improve effectiveness include investigations to help delineate the plume, and to evaluate the capture zone of the current extraction well. The recommendations for cost reduction include a potentially simplified system consisting only of liquid-phase carbon. Finally, clarification of cleanup goals is recommended, since specific cleanup goals have not yet been established.

Recommendations, and estimated cost increases/decreases associated with those recommendations, are presented in Table 7-1.

Table 7-1. Cost Summary Table

Recommendation	Reason	Estimated Change in			
		Capital Costs	Annual Costs	Lifecycle Costs*	Lifecycle Costs**
6.1.1 Delineate plume and evaluate capture zone	Effectiveness	\$25,000	\$5,000	\$175,000	\$105,600
6.1.2 Evaluate extraction well and pump	Effectiveness	\$10,000	\$0	\$10,000	\$10,000
6.1.3 Implement institutional controls	Effectiveness	\$15,000	\$0	\$15,000	\$15,000
6.1.4 Initial investigation near CSP-7 and old treatment area	Effectiveness	\$25,000	\$0	\$25,000	\$25,000
6.2.1 a) Switch to only liquid-phase carbon	Cost Reduction	\$125,000	(\$22,000)	(\$535,000)	(\$230,000)
b) Further reduce process monitoring			(\$10,000)	(\$300,000)	(\$161,100)
6.2.2 Reduce heating in building (lower temperature)	Cost Reduction	\$0	(\$1,000)	(\$30,000)	(\$16,100)
6.3.1 Stop performing data validation	Technical improvement	\$0	\$0	\$0	\$0
6.4.1 Establish cleanup levels	Site Close	\$0	\$0	\$0	\$0

Costs in parentheses imply cost reductions.

* assumes 30 years of operation with a discount rate of 0% (i.e., no discounting)

** assumes 30 years of operation with a discount rate of 5% and no discounting in the first year

FIGURES

FIGURE 1-1. SITE LAYOUT SHOWING THE LOCATIONS OF THE MONITORING WELLS AND THE EXTRACTION WELL.

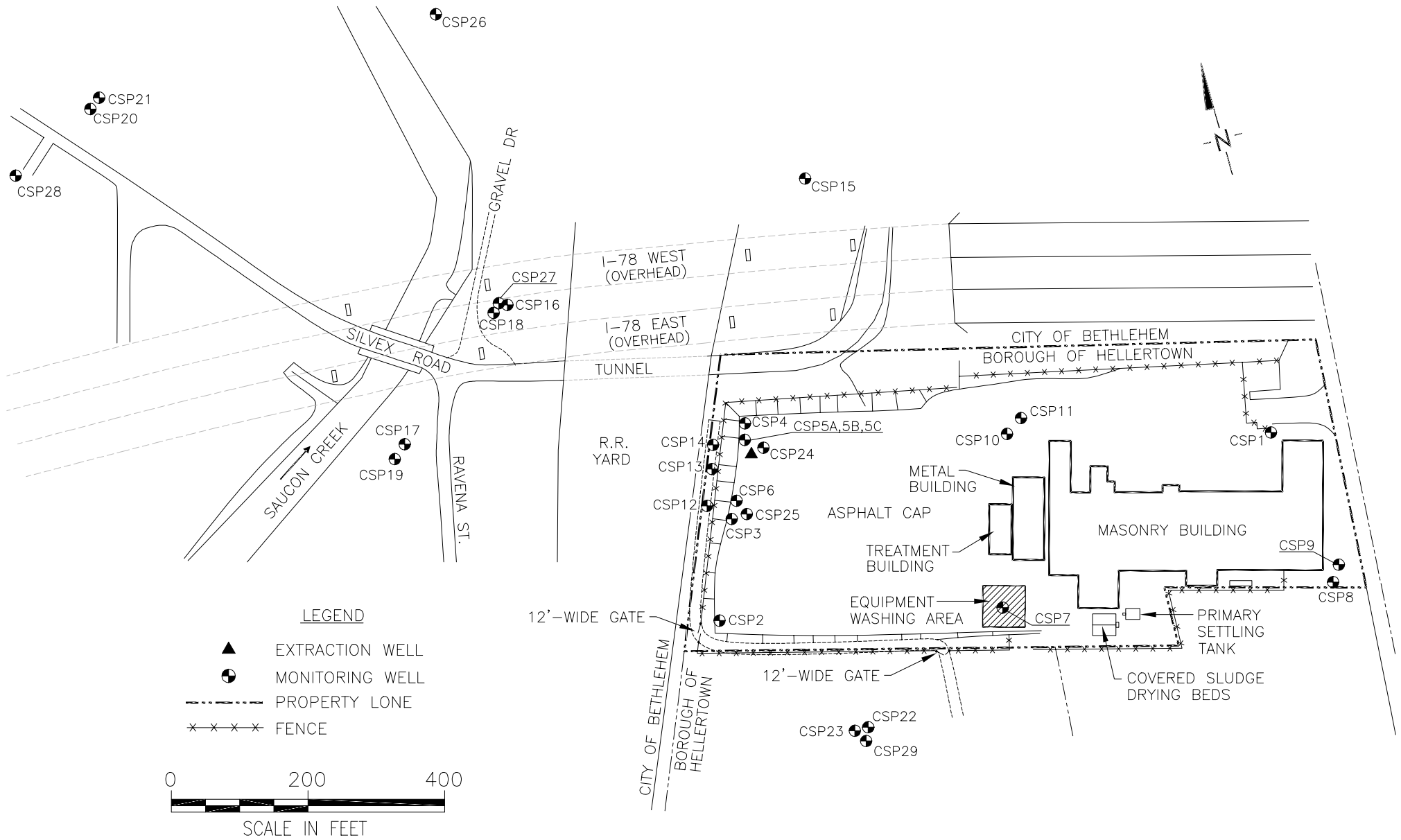

(Note: This figure is adapted from Figure 2-1 from the Hellertown Manufacturing Company Site Hydrogeological Conditions Evaluation, Ecology and Environment, August 1994.)

FIGURE 1-2. CROSS SECTION OF THE GEOLOGY UNDERLYING THE HELLERTOWN MANUFACTURING SUPERFUND SITE.

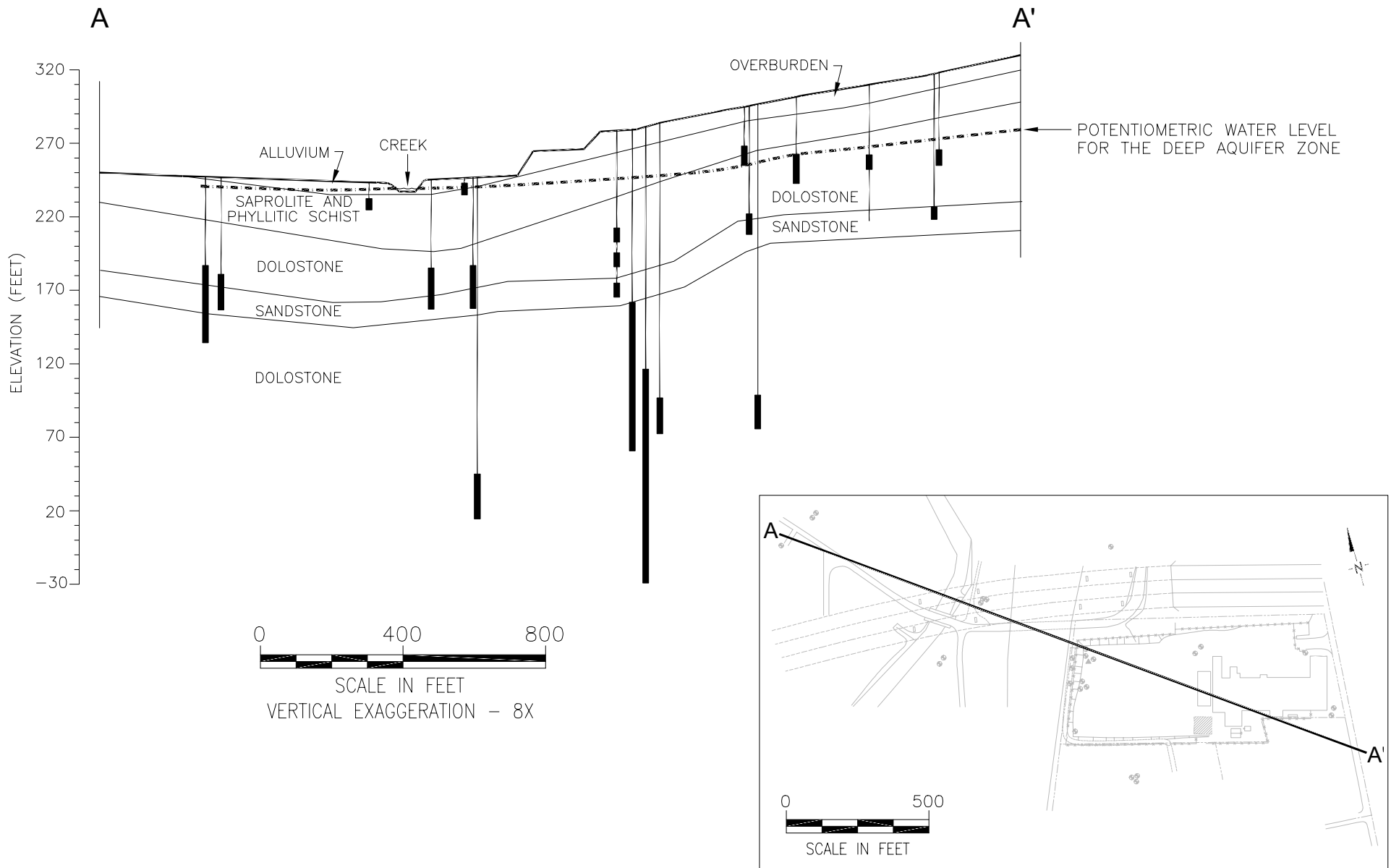

(Note: This figure is taken from Figure 4-1 from the Hellertown Manufacturing Company Site Hydrogeological Conditions Evaluation, Ecology and Environment, August 1994.)