

FINAL REPORT

Long-Term Performance Assessment at a Highly Characterized
and Instrumented DNAPL Source Area Following
Bioaugmentation

ESTCP Project ER-201428

MARCH 2018

Charles Schaefer, Ph.D.
CDM Smith

Graig Lavorgna
APTIM Federal Services

Michael Annable, Ph.D. and Alexander Haluska
University of Florida

Distribution Statement A

This document has been cleared for public release



Page Intentionally Left Blank

This report was prepared under contract to the Department of Defense Environmental Security Technology Certification Program (ESTCP). The publication of this report does not indicate endorsement by the Department of Defense, nor should the contents be construed as reflecting the official policy or position of the Department of Defense. Reference herein to any specific commercial product, process, or service by trade name, trademark, manufacturer, or otherwise, does not necessarily constitute or imply its endorsement, recommendation, or favoring by the Department of Defense.

Page Intentionally Left Blank

REPORT DOCUMENTATION PAGE

Form Approved
OMB No. 0704-0188

Public reporting burden for this collection of information is estimated to average 1 hour per response, including the time for reviewing instructions, searching existing data sources, gathering and maintaining the data needed, and completing and reviewing this collection of information. Send comments regarding this burden estimate or any other aspect of this collection of information, including suggestions for reducing this burden to Department of Defense, Washington Headquarters Services, Directorate for Information Operations and Reports (0704-0188), 1215 Jefferson Davis Highway, Suite 1204, Arlington, VA 22202-4302. Respondents should be aware that notwithstanding any other provision of law, no person shall be subject to any penalty for failing to comply with a collection of information if it does not display a currently valid OMB control number. **PLEASE DO NOT RETURN YOUR FORM TO THE ABOVE ADDRESS.**

| | | | | | |
|--|-----------------------------|--------------------------------|---|--|--|
| 1. REPORT DATE (DD-MM-YYYY) 12-22-2017 | | 2. REPORT TYPE Final | | 3. DATES COVERED (From - To) Sept. 2017 to Dec. 2017 | |
| 4. TITLE AND SUBTITLE Long Term Performance Assessment at a Highly Characterized and Instrumented DNAPL Source Area following Bioaugmentation | | | | 5a. CONTRACT NUMBER W912HQ-14-C-0030 | |
| | | | | 5b. GRANT NUMBER NA | |
| | | | | 5c. PROGRAM ELEMENT NUMBER NA | |
| 6. AUTHOR(S) Schaefer, Charles E., Ph.D. (CDM Smith) Lavgorna, Graig M. (APTIM Federal Services) Annable, Michael D., Ph.D. (University of Florida) Haluska, Alexander. (University of Florida) | | | | 5d. PROJECT NUMBER NA | |
| | | | | 5e. TASK NUMBER NA | |
| | | | | 5f. WORK UNIT NUMBER NA | |
| 7. PERFORMING ORGANIZATION NAME(S) AND ADDRESS(ES) APTIM Federal Services, LLC. 17 Princess Road Lawrenceville, NJ 08648 | | | | 8. PERFORMING ORGANIZATION REPORT NUMBER NA | |
| 9. SPONSORING / MONITORING AGENCY NAME(S) AND ADDRESS(ES) Environmental Security Technology Certification Program 4800 Mark Center Drive, Suite 17D08 Alexandria, VA 22350-3605 | | | | 10. SPONSOR/MONITOR'S ACRONYM(S) ESTCP | |
| | | | | 11. SPONSOR/MONITOR'S REPORT NUMBER(S) NA | |
| 12. DISTRIBUTION / AVAILABILITY STATEMENT Distribution Statement A: Approved for Public Release, Distribution is Unlimited | | | | | |
| 13. SUPPLEMENTARY NOTES None | | | | | |
| 14. ABSTRACT The long-term behavior in chlorinated ethene DNAPL source areas following in situ bioaugmentation in heterogeneous media was investigated in this study. Monitoring was performed up to 3.7 years following active bioremediation using a high-density monitoring network. Soil sampling, passive flux meters, and push-pull tracer testing was performed. Results showed that, despite the absence of lactate, lactate fermentation transformation products, or hydrogen, biogeochemical conditions remained favorable for the reductive dechlorination of chlorinated ethenes. While ethene levels suggested relatively low dechlorination of the parent TCE and daughter products, CSIA showed that the extent of complete dechlorination was much greater than indicated by ethene generation. Results of the push-pull tracer testing confirmed that DNAPL remained in a portion of the source area, consistent with soil and groundwater data. Overall, study results suggest biological processes may persist to treat TCE years after cessation of active bioremediation, thereby serving as an important component of remedial design and long-term attenuation. Reliance on ethene generation alone as an indicator of complete dechlorination significantly underestimated the extent of complete dechlorination, as CSIA analysis provided a more reliable estimate; highlighting the importance of utilizing isotopic data to determine dechlorination rates in complex systems. Results also emphasize the need for high-resolution characterization and monitoring to facilitate improved design and performance monitoring to optimize resources to achieve remedial goals. | | | | | |
| 15. SUBJECT TERMS TCE, DNAPL, bioaugmentation, bioremediation, CSIA, partitioning tracers, flux | | | | | |
| 16. SECURITY CLASSIFICATION OF: | | | 17. LIMITATION OF ABSTRACT UU | 18. NUMBER OF PAGES 151 | 19a. NAME OF RESPONSIBLE PERSON Dr. Charles Schaefer |
| a. REPORT U | b. ABSTRACT U | c. THIS PAGE U | | | 19b. TELEPHONE NUMBER (include area code) 732-590-4633 |

Page Intentionally Left Blank

FINAL REPORT

Project: ER-201428

TABLE OF CONTENTS

| | Page |
|---|-------------|
| EXECUTIVE SUMMARY | ES-1 |
| 1.0 INTRODUCTION | 1 |
| 1.1 BACKGROUND | 1 |
| 1.2 OBJECTIVE OF THE DEMONSTRATION | 2 |
| 1.3 REGULATORY DRIVERS | 2 |
| 2.0 TECHNOLOGY | 5 |
| 2.1 TECHNOLOGY DESCRIPTION | 5 |
| 2.1.1 DNAPL Source Area Characterization Tools | 5 |
| 2.1.2 Background- Bioaugmentation for DNAPL Sources | 5 |
| 2.2 TECHNOLOGY DEVELOPMENT | 6 |
| 2.2.1 Long Term and Detailed Assessment of Bioaugmentation for Treatment of DNAPL Sources | 6 |
| 2.2.2 DNAPL Source Area Assessment and Bioaugmentation: Alameda Point, CA | 6 |
| 2.2.3 Overall Approach for the Long-Term Performance Assessment | 15 |
| 2.3 ADVANTAGES AND LIMITATIONS OF THE TECHNOLOGY | 16 |
| 2.3.1 Advantages | 16 |
| 2.3.2 Limitations | 16 |
| 3.0 PERFORMANCE OBJECTIVES | 19 |
| 3.1 ASSESS EFFECTIVENESS OF DNAPL MASS REMOVAL IN LOW PERMEABILITY MATERIALS | 19 |
| 3.1.1 Data Requirements for DNAPL Removal | 19 |
| 3.1.2 Success Criteria for DNAPL Removal | 20 |
| 3.2 ASSESS THE LONG-TERM DECHLORINATION ACTIVITY (BIOTIC/ABIOTIC) FOLLOWING ACTIVE REMEDIATION | 20 |
| 3.2.1 Data Requirements for assessing long-term dechlorination activity | 20 |
| 3.2.2 Success Criteria for assessing long-term dechlorination activity | 20 |
| 3.3 DETERMINE DOWNGRAIDENT IMPACTS | 20 |
| 3.3.1 Data Requirements for determining downgradient impacts | 20 |
| 3.3.2 Success Criteria for determining downgradient impacts | 20 |
| 3.4 IDENTIFY CHARACTERIZATION AND MONITORING TOOLS THAT WERE MOST CRITICAL FOR DESIGNING AND ASSESSING TREATMENT | 21 |
| 3.4.1 Data requirements to identify characterization and monitoring tools that were most critical for designing and assessing treatment | 21 |
| 3.4.2 Success criteria to identify characterization and monitoring tools that were most critical for designing and assessing treatment | 21 |

TABLE OF CONTENTS (Continued)

| | Page |
|--|-------------|
| 4.0 SITE DESCRIPTION | 23 |
| 4.1 SITE SELECTION | 23 |
| 4.2 SITE LOCATION AND HISTORY | 23 |
| 4.3 SITE GEOLOGY AND HYDROGEOLOGY | 25 |
| 4.4 CONTAMINANT SOURCE AND DISTRIBUTION | 25 |
| 4.5 TEST PLOT LOCATION | 26 |
| 5.0 TEST DESIGN | 27 |
| 5.1 CONCEPTUAL EXPERIMENTAL DESIGN | 27 |
| 5.2 BASELINE CHARACTERIZATION ACTIVITIES | 27 |
| 5.3 DESIGN AND LAYOUT OF TECHNOLOGY COMPONENTS | 27 |
| 5.3.1 MLS Well Installation | 28 |
| 5.3.2 Groundwater Recirculation System for Implementing the Partitioning Tracer Test ... | 29 |
| 5.3.3 Power | 29 |
| 5.4 FIELD TESTING | 32 |
| 5.4.1 Groundwater Sampling | 32 |
| 5.4.2 Flux Measurements using Passive Flux Meters | 36 |
| 5.4.3 Soil Investigation | 37 |
| 5.4.4 Partitioning Tracer Test | 38 |
| 5.4.5 Demobilization | 39 |
| 5.5 DATA ANALYSIS | 39 |
| 5.5.1 Groundwater | 39 |
| 5.5.2 Soil | 39 |
| 5.5.3 Partitioning Tracer Test | 39 |
| 5.5.4 Overall Assessment – Qualitative and Quantitative Aspects | 40 |
| 5.6 SAMPLING METHODS | 41 |
| 5.6.1 Groundwater Sampling | 41 |
| 5.6.2 Decontamination | 42 |
| 5.6.3 Analytical and Sample Preservation for Groundwater Samples | 42 |
| 5.6.4 Groundwater Sampling Locations and Frequency | 43 |
| 5.6.5 Analytical and Sample Preservation for Soil Samples | 47 |
| 5.6.6 Soil Sampling Locations and Frequency | 47 |
| 5.6.7 Quality Assurance for Groundwater and Soil Sampling and Analysis | 48 |
| 5.7 RESULTS | 51 |
| 5.7.1 Soil Core Results | 51 |
| 5.7.2 Groundwater Monitoring Results | 52 |
| 5.7.3 Passive Flux Meters | 61 |
| 5.7.4 Push-Pull Partitioning Tracer Tests | 62 |
| 6.0 PERFORMANCE ASSESSMENT | 65 |
| 6.1 ASSESS EFFECTIVENESS OF DNAPL REMOVAL IN LOWER PERMEABILITY MATERIALS | 65 |

TABLE OF CONTENTS (Continued)

| | Page |
|---|-------------|
| 6.2 ASSESS LONG-TERM DECHLORINATION ACTIVITY | 65 |
| 6.3 DETERMINE DOWNGRADIENT IMPACTS | 65 |
| 6.4 IDENTIFY THE CHARACTERIZATION AND MONITORING TOOLS THAT WERE MOST CRITICAL FOR PERFORMANCE ASSESSMENT | 65 |
| 6.5 ASSESS OVERALL PERFORMANCE WITH RESPECT TO APPLICABILITY TO OTHER DNAPL SOURCE AREAS | 65 |
| 7.0 COST ASSESSMENT | 67 |
| 7.1 COST MODEL | 67 |
| 7.1.1 Capital Costs | 67 |
| 7.1.2 O&M Costs | 67 |
| 7.1.3 Demonstration-Specific Costs | 69 |
| 7.2 COST DRIVERS | 69 |
| 7.2.1 General Considerations | 69 |
| 7.2.2 Competing Treatment Technologies | 69 |
| 7.3 COST ANALYSIS | 69 |
| 7.3.1 Base Cost Template | 69 |
| 7.3.2 Long-Term Performance Assessment following Bioaugmentation Program | 71 |
| 8.0 IMPLEMENTATION ISSUES | 77 |
| 9.0 REFERENCES | 79 |
| APPENDIX A POINTS OF CONTACT | A-1 |
| APPENDIX B BIOAUGMENTATION FOR TREATMENT OF DNAPL SOURCES: INSIGHTS FROM ALAMEDA POINT PLUME 4-1 | B-1 |
| APPENDIX C SOIL ANALYTICAL DATA SUMMARY TABLES | C-1 |
| APPENDIX D GROUNDWATER ANALYTICAL DATA SUMMARY TABLES | D-1 |
| APPENDIX E COST ESTIMATE DETAILS: INCREMENTAL COST ESTIMATE TO "UP- GRADE" TO THE DEMONSTRATED LONG-TERM PERFORMANCE ASSESSMENT FOLLOWING BIOAUGMENTATION | E-1 |

LIST OF FIGURES

| | | Page |
|-------------|---|-------------|
| Figure 2.1 | Plume 4-1 at Alameda..... | 7 |
| Figure 2.2 | DNAPL Source Zone after Initial Characterization..... | 8 |
| Figure 2.3 | High Resolution Vertical Delineation of DNAPL Distribution and Permeability . | 8 |
| Figure 2.4 | Site Layout for the DNAPL Source Area at Alameda Point | 9 |
| Figure 2.5 | MLS Wells | 10 |
| Figure 2.6 | Comparison of PTT Results..... | 11 |
| Figure 2.7 | Conceptual Geologic Cross Section of DNAPL Source Area | 11 |
| Figure 2.8 | Examples of DNAPL Source Areas where Residual DNAPL Sources Reside and Persist in Lower Permeability Zones | 12 |
| Figure 2.9 | Chlorinated Ethene, Ethene, and DHC Results | 13 |
| Figure 4.1 | Site Location Map..... | 24 |
| Figure 4.2 | Plume 4-1 TCE Contour | 26 |
| Figure 5.1 | MLS Well Construction Details..... | 28 |
| Figure 5.2 | Groundwater Recirculation and Tracer Delivery System..... | 30 |
| Figure 5.3 | PTT Recirculation System P&ID..... | 31 |
| Figure 5.4 | Plume 4-1 Monitoring Locations | 33 |
| Figure 5.5 | Chain of Custody Form..... | 50 |
| Figure 5.6 | TCE and DCE Soil Concentrations in Soil Cores..... | 52 |
| Figure 5.7 | Groundwater Chlorinated Ethene and Ethene Results for SMLS Locations Screened within the Lower Permeability Materials..... | 55 |
| Figure 5.8 | Groundwater Chlorinated Ethene and Ethene Results for SMLS and Extraction Well Locations Screened within the Higher Permeability Materials..... | 56 |
| Figure 5.9 | Groundwater Chlorinated Ethene and Ethene Results for PMLS Well Locations Screened within the Higher Permeability Materials | 58 |
| Figure 5.10 | Carbon Isotopic Enrichment Measured as a Function of the Total Chlorinated Ethene Concentration in both the Low (top) and High (bottom) Permeability Materials Emanating from the Existing DNAPL Sources through the PMLS Wells | 59 |
| Figure 5.11 | Darcy Velocity Measured over the Course of the Study Using PFMs. | 61 |
| Figure 5.12 | Summation of Chlorinated Ethene and Ethene Molar Flux | 62 |
| Figure 5.13 | Results of the Push-Pull Partitioning Tracer Test at SPW-4 | 62 |

LIST OF FIGURES

| | Page |
|--|-------------|
| Figure 5.14 EST Model Regressed to Both Bromide and DCE Data during the Push-Pull Test at SPW-4 | 63 |
| Figure 5.15 Results of the Push-Pull Partitioning Tracer Test at SPW3-1 | 64 |
| Figure 5.16 EST Model Regressed to Both Bromide and DCE Data during the Push-Pull Test at SPW3-1 | 64 |
| Figure 7.1 Base Plume Characteristics..... | 70 |
| Figure 7.2 Long-Term Performance Assessment following Bioaugmentation..... | 72 |
| Figure 7.3 Expanded Zone Long-Term Performance Assessment following Bioaugmentation | 74 |

LIST OF TABLES

| | | Page |
|------------|---|-------------|
| Table 1.1 | Federal Maximum Contaminant Levels and California Water Quality Standards | 3 |
| Table 2.1 | Key Questions, the Approach for Answering the Questions, and Relevance to Other DoD DNAPL Source Areas. | 15 |
| Table 3.1 | Performance Objectives | 19 |
| Table 4.1 | Site Selection Criteria | 23 |
| Table 5.1 | Timeline of Field Operations | 32 |
| Table 5.2 | Groundwater Sampling Locations and Rationale | 34 |
| Table 5.3 | Selected Locations and Rationale for Microbial Analyses and CSIA | 36 |
| Table 5.4 | Analytical Methods, Preservation, and Containers (Groundwater) | 43 |
| Table 5.5 | Location and Parameter Summary – Groundwater Sampling Event No. 1 | 44 |
| Table 5.6 | Location and Parameter Summary – Groundwater Sampling Event No. 2 | 45 |
| Table 5.7 | Location and Parameter Summary – Groundwater Sampling Event No. 3 | 46 |
| Table 5.8 | Analytical Methods, Preservation, and Containers (Soil)..... | 47 |
| Table 5.9 | Location and Parameter Summary – Soil Sampling Event..... | 47 |
| Table 5.10 | Ratios of the Final (Post-Bioremediation) Measured Groundwater Concentrations to those Measured Prior to Bioremediation | 53 |
| Table 5.11 | Molar Fraction of Ethene to Chlorinated Ethenes Measured Prior to Bioaugmentation, and at the Last Measured Rebound Event | 57 |
| Table 7.1 | Demonstration Cost Components | 68 |
| Table 7.2 | Summary of Base Case Site Characteristics and Design Parameters | 71 |
| Table 7.3 | Incremental Cost Estimate to "Up-Grade" to the Demonstrated Long-Term Performance Assessment following Bioaugmentation for Base Case | 73 |
| Table 7.4 | Summary of Expanded Zone Site Characteristics and Design Parameters..... | 74 |
| Table 7.5 | Incremental Cost Estimate to "Up-Grade" to the Demonstrated Long-Term Performance Assessment following Bioaugmentation for Expanded Zone Case ... | 75 |

ACRONYMS AND ABBREVIATIONS

µg/L micrograms per liter

µM micromolar

AFB Air Force Base

APP Accident Prevention Plan

ASTM American Society for Testing and Materials

bgs below ground surface

°C degrees Celsius

COC Chain-of-Custody

CSIA Compound Specific Isotope Analysis

DCE *cis*-1,2-Dichloroethene

DHC *Dehalococcoides* sp.

DNAPL Dense Non-Aqueous Phase Liquid

DoD U.S. Department of Defense

EST Equilibrium Stream Tube

ESTCP Environmental Security Technology Certification Program

Fe Iron

FRTR Federal Remediation Technologies Roundtable

ft foot or feet

g gram

gpm gallons per minute

HPT Hydraulic Profiling Tool

IPR In-Progress Review

IR Installation Restoration

kg kilogram

L liter

LNAPL Light Non-Aqueous Phase Liquid

MCL Maximum Contaminant Level

mg/kg milligrams per kilogram

mg/L milligrams per liter

MIP Membrane Interface Probe

mL milliliters

mL/min milliliters per minute

MLS Multi-Level Sampling
Mn Manganese

NPV Net Present Value

O&M Operation and Maintenance
ORP Oxidation-Reduction Potential
OU Operable Unit

P&ID Piping and Instrumentation Diagram
PCE Tetrachloroethene
PEW Plume Extraction Well
PFM Passive Flux Meter
PID Photoionization Detector
PMLS Plume Multi-Level Sampling
PTT Partitioning Tracer Test

QA Quality Assurance
QC Quality Control
QED QED Environmental Systems

SERDP Strategic Environmental Research and Development Program
SIW Source Injection Well
SMLS Source Multi-Level Sampling
SOP Standard Operating Procedure

TCE Trichloroethene
TOC Total Organic Carbon

USEPA/EPA U.S. Environmental Protection Agency

VC Vinyl Chloride
VFA Volatile Fatty Acid
VOA Volatile Organic Analysis
VOC Volatile Organic Compound

XRD X-ray Diffraction

ACKNOWLEDGEMENTS

We wish to thank the Navy's environmental staff at Alameda, CA for their support during this demonstration. In particular, special thanks to Doug DeLong and William McGinnis for their dedication to the project and its success. We also wish to thank ESTCP for their financial support, and Dr. Andrea Leeson, the Environmental Restoration Program Manager at ESTCP, for her guidance. We would also like to acknowledge and thank the capable staff at APTIM that conducted the site soil and groundwater monitoring, assisted with tracer testing system design, installation and operation, data management, and analytical support. In particular, Tim Ault, Kenneth Lee, Mark Seibert, Kevin O'Leary, Sheryl Streger, Randi Rothmel, Paul Hedman, and Antonio Soto of APTIM were vital to project success. Their efforts ultimately lead to the quality experimental results and findings demonstrated during this project.

Page Intentionally Left Blank

EXECUTIVE SUMMARY

The long-term behavior in chlorinated ethene dense non-aqueous phase liquid (DNAPL) source areas following in situ bioaugmentation in heterogeneous media was investigated in this study. This study was performed within Plume 4-1 (operable unit 2B) at Alameda Point, CA, where a detailed high-resolution site assessment in a DNAPL source area was followed by several weeks of active in situ bioremediation that included bioaugmentation, delivery of sodium lactate, and groundwater recirculation.

Monitoring was performed up to 3.7 years following active bioremediation using a high-density monitoring network that included several discrete interval multi-level sampling wells. Soil sampling, passive flux meter deployments, and push-pull tracer testing (using bromide and partitioning tracers) also were performed. Results showed that, despite the absence of lactate, lactate fermentation transformation products, or hydrogen, biogeochemical conditions remained favorable for the reductive dechlorination of chlorinated ethenes. In locations where soil data showed that TCE DNAPL sources persisted, local contaminant rebound was observed in groundwater, whereas no rebound or continuous decreases in chlorinated ethenes were observed in locations where DNAPL sources were treated. While ethene levels measured 3.7 years after active treatment suggested relatively low (2 to 30%) dechlorination of the parent TCE and daughter products, compound specific isotope analysis (CSIA) for carbon showed that the extent of complete dechlorination was much greater than indicated by ethene generation, and that the estimated first-order rate constant describing the complete dechlorination of TCE at 3.7 years following active bioremediation was approximately 3.6 yr^{-1} .

Results of the push-pull tracer testing confirmed that DNAPL remained in a portion of the source area. The tracer testing was consistent with the results of the soil and groundwater data, and showed that DNAPL removal in one portion of the site had been minimal (compared to another portion of the site where DNAPL had been effectively removed).

Overall, results of this study suggest that biological processes may persist to treat TCE for years after cessation of active bioremediation, thereby serving as an important component of remedial treatment design and long-term attenuation. Reliance on ethene generation alone as an indicator of complete dechlorination significantly underestimated the extent of complete dechlorination, as CSIA provided a more reliable estimate; this result highlights the importance of utilizing isotopic data to determine dechlorination rates in complex systems. Results of this study also emphasize the need for high-resolution characterization and monitoring to facilitate improved design and performance monitoring (short- and long-term) to optimize resources needed to achieve remedial goals.

Page Intentionally Left Blank

1.0 INTRODUCTION

1.1 BACKGROUND

Management of sites that are impacted by chlorinated solvent dense non-aqueous phase liquids (DNAPLs), especially tetrachloroethene (PCE) or trichloroethene (TCE), is a major challenge for the Department of Defense (DoD). There are many DoD facilities that have DNAPL source areas present in unconsolidated aquifers, including Alameda Point, McGuire AFB, Pease AFB, and the Cape Canaveral Air Force Station. Recently, several laboratory and field demonstrations have indicated that bioaugmentation is a viable remedial option for DNAPL source areas. Because DNAPL source areas result in high concentration and persistent plumes, and because treatment of these source areas requires a significant investment of project resources, a thorough long-term performance assessment following bioaugmentation in DNAPL source areas is needed to optimize treatment and mitigate costs needed to attain remedial goals.

The key to a proper bioaugmentation performance assessment in DNAPL source areas, both long and short term, is establishing a detailed understanding of the DNAPL distribution, DNAPL mass, flux, and flow field prior to implementing the remedial technology. High resolution and detailed evaluation during bioaugmentation implementation also is vital for proper long-term performance assessment. In most instances, characterization of DNAPL source zones fails to obtain the high-resolution spatial information that is needed to assess performance and fails to utilize advanced tools that are able to quantify DNAPL mass, flux, and the flow field. Understanding amendment distribution relative to the location of DNAPL sources and understanding how DNAPL mass and flux has changed in response to treatment, serves as a basis for assessing long-term bioremediation performance. Unfortunately, few sites have undergone the high level of characterization needed to facilitate a detailed assessment of remedial performance in DNAPL source areas, making it impossible to properly assess remedial performance and determine the limits of remedial effectiveness.

Long term and detailed performance assessments using advanced tools within DNAPL source areas following bioaugmentation have, to the best of our knowledge, not been performed. Data collected during, or immediately after, active treatment while electron donor is still present and reductive dechlorination rates remain high, are typically not a good indication of remedial progress, as substantial rebound from DNAPL sources could occur as the reaction rates diminish. This lack of long term performance assessment data has resulted in an insufficient understanding of many basic issues related to remedial implementation, design, and monitoring, both for the source area and the resultant downgradient plume. Key unknowns related to treatment effectiveness that require quantification include:

- Identification of the practical limits of treatment effectiveness (e.g., attainment of MCLs);
- Extent to which reductive dechlorination continues after active remediation;
- Extent to which remedial amendments migrate and treat the downgradient plume;
- Long term geochemical and microbial community impacts; and
- Long term impacts on contaminant flux.

The intensive DNAPL characterization and bioaugmentation field demonstration recently performed at Alameda Point in cooperation with SERDP Project ER-1613, which utilized many advanced tools for assessing a DNAPL source area in overburden, provided an excellent opportunity to perform a detailed long-term performance assessment following bioaugmentation. This site was highly characterized and monitored both before and during bioaugmentation and remains instrumented to provide high-resolution groundwater monitoring data. Performing such an assessment following bioaugmentation of a highly characterized DNAPL source area now provides the DoD with much needed information regarding the long-term effectiveness of bioaugmentation for DNAPL sources, and will facilitate improved design, implementation, monitoring, and management of DNAPL-impacted aquifers.

This demonstration was a collaborative effort between APTIM Federal Services, CDM Smith, and the University of Florida.

1.2 OBJECTIVE OF THE DEMONSTRATION

The overall objective of this project is to perform a long-term performance assessment at a site where bioaugmentation was used to treat a highly characterized overburden DNAPL source area. Specifically, the long-term treatment impacts with respect to groundwater quality, DNAPL mass, contaminant flux, reductive dechlorination, geochemistry, and microbial structure were assessed. Attainment of these objectives would provide for improved remedial selection, design, and management of DNAPL source areas, and ultimately will provide the information necessary to apply bioaugmentation more cost effectively. Our approach was to carry out a detailed and intensive performance assessment within a DNAPL source area that has been previously characterized using advanced tools and flux measurement techniques as part of SERDP Project ER-1613 and has been carefully monitored during a recently completed bioaugmentation pilot test (performed by APTIM in conjunction with ER-1613). This assessment was initiated approximately 2 years following cessation of active treatment and employed multiple rounds of monitoring over the proposed 2-year demonstration period. The Plume 4-1 DNAPL source area at Alameda Point, CA, which is currently instrumented with several transects of multilevel samplers with highly discretized sampling intervals, was an ideal location for this intensive assessment to be performed and provided a unique opportunity to obtain a high resolution, long-term, and detailed performance assessment following bioaugmentation.

1.3 REGULATORY DRIVERS

TCE, along with its reductive dechlorination daughter products *cis*-1,2-dichloroethene (DCE), and vinyl chloride (VC), are regulated in drinking and ground water by both the U.S. Environmental Protection Agency (USEPA) and the state of California. The applicable groundwater standards are provided in Table 1.1.

Prior to bioaugmentation, TCE concentrations in the treatment areas were up to 4 orders of magnitude above both state and federal regulatory levels. It is significant to note that partial dechlorination of TCE, resulting in near-stoichiometric accumulation of either DCE and/or VC, would result in regulatory exceedances of these compounds as well.

Table 1.1 Federal Maximum Contaminant Levels and California Water Quality Standards

| Constituents | USEPA MCL (µg/L) | California WQS (µg/L) |
|-------------------------------------|---------------------------------|--------------------------------------|
| Trichloroethene (TCE) | 5 | 5 |
| <i>cis</i> -1,2-dichlorethene (DCE) | 70 | 6 |
| Vinyl Chloride (VC) | 2 | 0.5 |

Page Intentionally Left Blank

2.0 TECHNOLOGY

2.1 TECHNOLOGY DESCRIPTION

2.1.1 DNAPL Source Area Characterization Tools

To assess the effectiveness (or, potential effectiveness) of *in situ* remedial technologies in source areas, several tools have been developed and utilized to attain improved insight into both the contaminant distribution and the flow field. High resolution vertical multi-level sampling wells have proven to be very useful for understanding amendment and mass distribution in heterogeneous systems (Smith et al., 1991). Collection of soil or rock cores, with subsequent high-density sampling to determine contaminant concentrations relative to lithology, also has been used as a means to assess the potential for rebound and overall remedial effectiveness (Chapman and Parker, 2005).

Recently developed innovative approaches include the use of passive flux meters (PFMs), which allow for a high resolution vertical profile of both the hydraulic and contaminant fluxes (Annable et al., 2005). PFMs can be placed in existing wells and can be used to determine, with high resolution (as low as one inch), both the flow field and the vertical dissolved contaminant concentration profile. Other useful tools, such as membrane interface probes (MIPs) are able to provide a semi-quantitative high resolution (cm-scale) vertical profile of contaminant concentration. MIPs are particularly useful for isolating depth intervals where DNAPL sources may be present. The hydraulic profiling tool (HPT) provides a semi-quantitative high resolution (cm scale) vertical profile of the permeability and is useful for identifying high and low-flow zones within a source area or contaminant plume. HPT provides a much-improved assessment of the flow field that typically can be determined via visual observation of collected soil cores, and with much improved resolution that can be obtained using slug or pump tests. Partitioning tracer testing (PTT), which has been demonstrated in several DNAPL source areas, is useful for locating and quantifying DNAPL sources (Annable et al., 1998; Hartog et al., 2010). Compound specific isotope analysis (CSIA) has become a useful tool for evaluating treatment effectiveness and can also be used to identify DNAPL sources (Morrill et al., 2009; Hunkeler et al., 2011).

2.1.2 Background- Bioaugmentation for DNAPL Sources

For chlorinated ethenes, bioaugmentation typically involves the subsurface injection of *Dehalococcoides* sp. (DHC), or closely related strains, that are capable of completely dechlorinating PCE and TCE. Electron donor (e.g., lactate, vegetable oil) and nutrients are also generally added to support DHC growth. Bioaugmentation has been shown to enhance the rate of PCE DNAPL dissolution in sand columns and flow cells by factors ranging from approximately 1.1 to 21 (Glover et al., 2007; Amos et al., 2008; Amos et al., 2009). Our laboratory studies with PCE in bedrock fractures also indicated that bioaugmentation was effective for treating DNAPL sources (Schaefer et al., 2010). Studies have noted, however, that the elevated dissolved contaminant concentration inhibits the complete dechlorination of PCE to ethene, and that this complete dechlorination likely will occur either downgradient of the DNAPL sources or after dissolved concentrations diminish to do depletion of the DNAPL sources (Adamson et al., 2003).

Field scale applications of bioaugmentation or biostimulation to treat PCE or TCE DNAPL in unconsolidated materials have been performed (USEPA, 2004; ITRC, 2007; Hood et al., 2008). Results generally have been consistent with the laboratory studies described in the previous paragraph. These results suggest that biostimulation/bioaugmentation can be effective for treating DNAPL sources in unconsolidated materials.

2.2 TECHNOLOGY DEVELOPMENT

2.2.1 Long Term and Detailed Assessment of Bioaugmentation for Treatment of DNAPL Sources

Increased attention has been given to long term performance and impacts following implementation of bioremediation, particularly for chlorinated solvents. Issues such as long term geochemical impacts, long term shifts in microbial populations, sustained (following active remediation) dechlorination due to processes such as microbial decay, and contaminant rebound from low permeability zones and/or residual DNAPL sources have been identified. Insight into these processes as they relate to long-term behavior following bioaugmentation treatment in DNAPL source areas are of particular interest due to the long-term impacts DNAPL sources can have on the dissolved contaminant plume, and due to the difficulty in attaining MCLs within DNAPL source areas.

The DNAPL source area bioaugmentation studies described in the previous section have not undergone any long-term and detailed performance assessments, thus the limits of remedial effectiveness and the extent to which dechlorination continues with time are unknown. In addition, the studies described above provide little insight into the efficacy of bioaugmentation for treating DNAPL sources that reside in low (or, lower) permeability materials. The one exception is a bioaugmentation demonstration performed at the Cape Canaveral Air Force station (USEPA, 2004; Hood et al., 2008), where limited groundwater sampling was performed 22 months following cessation of remedial activities. No rebound in TCE was observed (TCE remained at <50 µg/L), and substantial decreases in DCE, VC, and ethene were observed following active treatment. However, these data provide only limited insight with regard to long-term performance assessment because 1) only limited biogeochemical information was collected, 2) groundwater sampling was performed in wells with 10-ft screens, thus high resolution sampling information was not collected, 3) treatment was targeted in a permeable sandy zone where flow was likely controlled by thin zones of coarse shell fragments, and 4) the most substantial levels of TCE DNAPL were in an underlying zone of lower permeability (described as a silty/clayey sand), which was not targeted by this study. In addition, many of the advanced tools used for assessing DNAPL source areas, including high resolution groundwater sampling, PFMs, MIP, and PTT were not used in either the DNAPL characterization (pre-treatment) or in the post-treatment evaluation. Thus, a detailed long-term performance assessment at a well-characterized overburden DNAPL source area following bioaugmentation has not, to the best of our knowledge, been reported in the literature.

2.2.2 DNAPL Source Area Assessment and Bioaugmentation: Alameda Point, CA

Our initial field efforts for Plume 4-1 at Alameda Point, CA (in cooperation with SERDP Project ER-1613) focused on evaluating DNAPL architecture and dissolved flux from a DNAPL source area in overburden materials. The dissolved plume emanating for the source area is substantial, and (prior to our investigation) the extent of the potential DNAPL source area was poorly defined.

Figure 2.1 shows the high concentration portion of the plume, and the suspected location of the DNAPL source area prior to our investigation. The flow field and hydrogeology associated with the source area and plume also were poorly understood.

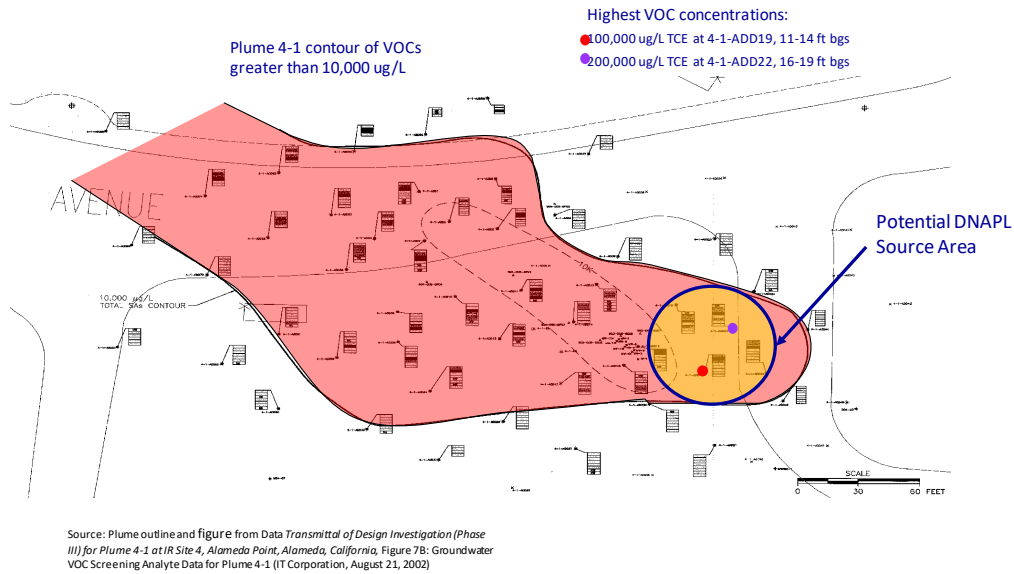
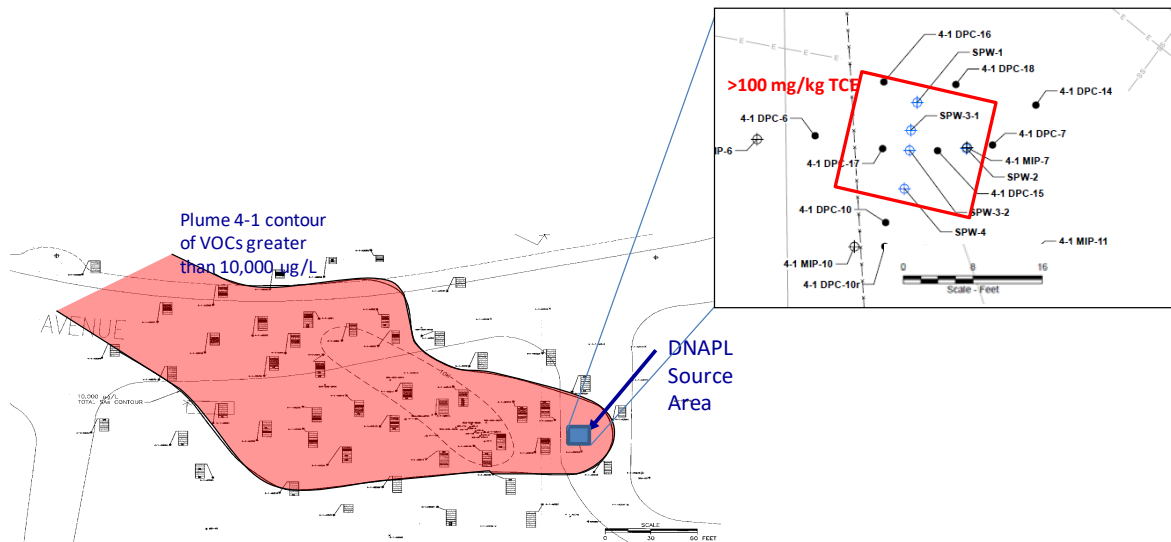

Figure 2.1 Plume 4-1 at Alameda

The TCE plume > 10,000 µg/L is shown, along with the region identified as the potential DNAPL zone at the start of the investigation.

Initial characterization efforts were performed using MIP and HPT investigation tools to determine potential locations of DNAPL sources and assess the permeability field, respectively. Soil cores then were collected, and high-resolution soil sampling was performed to verify the presence of TCE DNAPL. This information was used to determine the extent of the DNAPL source area, and to initiate development of a site conceptual model for the source area. These initial characterization steps indicated that the DNAPL source area was limited to a relatively small footprint (15 ft x 15 ft), and a depth interval of about 4 feet. The footprint of the TCE DNAPL source area is shown in Figure 2.2. Using data from the MIP, HPT, and soil investigation, a high resolution vertical delineation of the DNAPL distribution and permeability was obtained. As shown in Figure 2.3, the collected data provided a consistent description of the DNAPL architecture.



Source: Plume outline and figure from Data Transmittal of Design Investigation (Phase III) for Plume 4-1 at IR Site 4, Alameda Point, Alameda, California, Figure 7B: Groundwater VOC Screening Analyte Data for Plume 4-1 (IT Corporation, August 21, 2002)

Figure 2.2 DNAPL Source Zone after Initial Characterization

Based on initial DNAPL investigation results, a much smaller DNAPL source area than originally anticipated was identified.

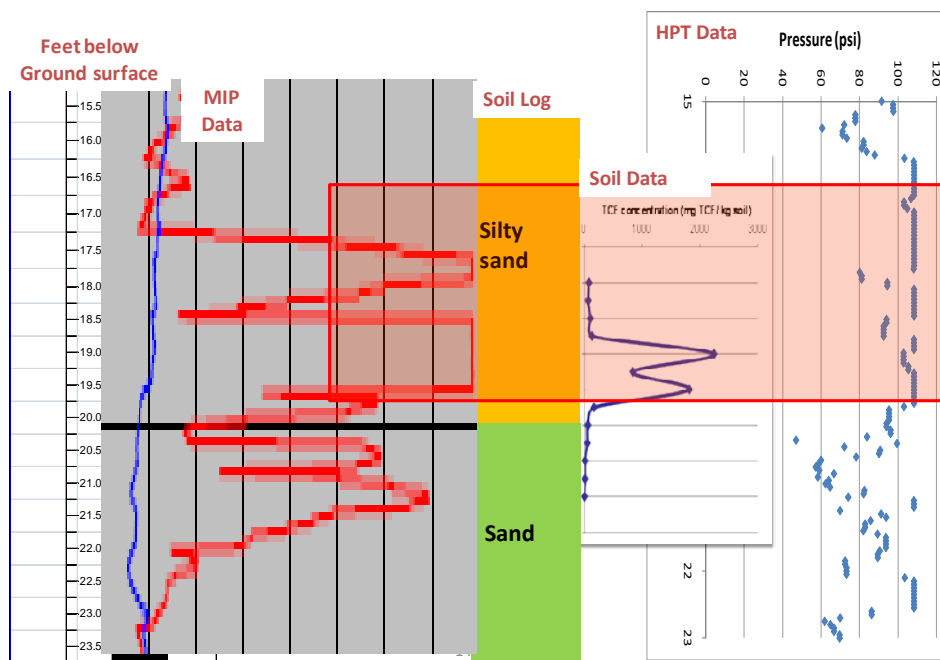

Figure 2.3 High Resolution Vertical Delineation of DNAPL Distribution and Permeability

Soil log combined with the HPT data show that the silty sand has a much lower permeability (as indicated by the much greater pressure response on the HPT) than the underlying sand. The MIP and soil data show that the DNAPL sources resided within the lower permeability silty sand.

The DNAPL source area was then instrumented with 8 multi-level sampling (MLS) wells to serve as transects through the source area, a downgradient transect of 6 MLS wells, and 3 injection and 4 extraction wells to re-circulate groundwater (amended with tracers or bioremediation amendments) through the source area (Figure 2.4). The MLS wells consisted of seven 0.5-foot screen intervals, isolated with bentonite seals. Figure 2.5 shows the MLS wells, and their illustrated placement in the subsurface. MLS wells allowed for monitoring of both the high and low permeability zones. A depth interval of approximately 15 to 24 ft bgs was targeted as the DNAPL source area, and was the focus of subsequent characterization and (eventually) the target of the applies bioaugmentation treatment.

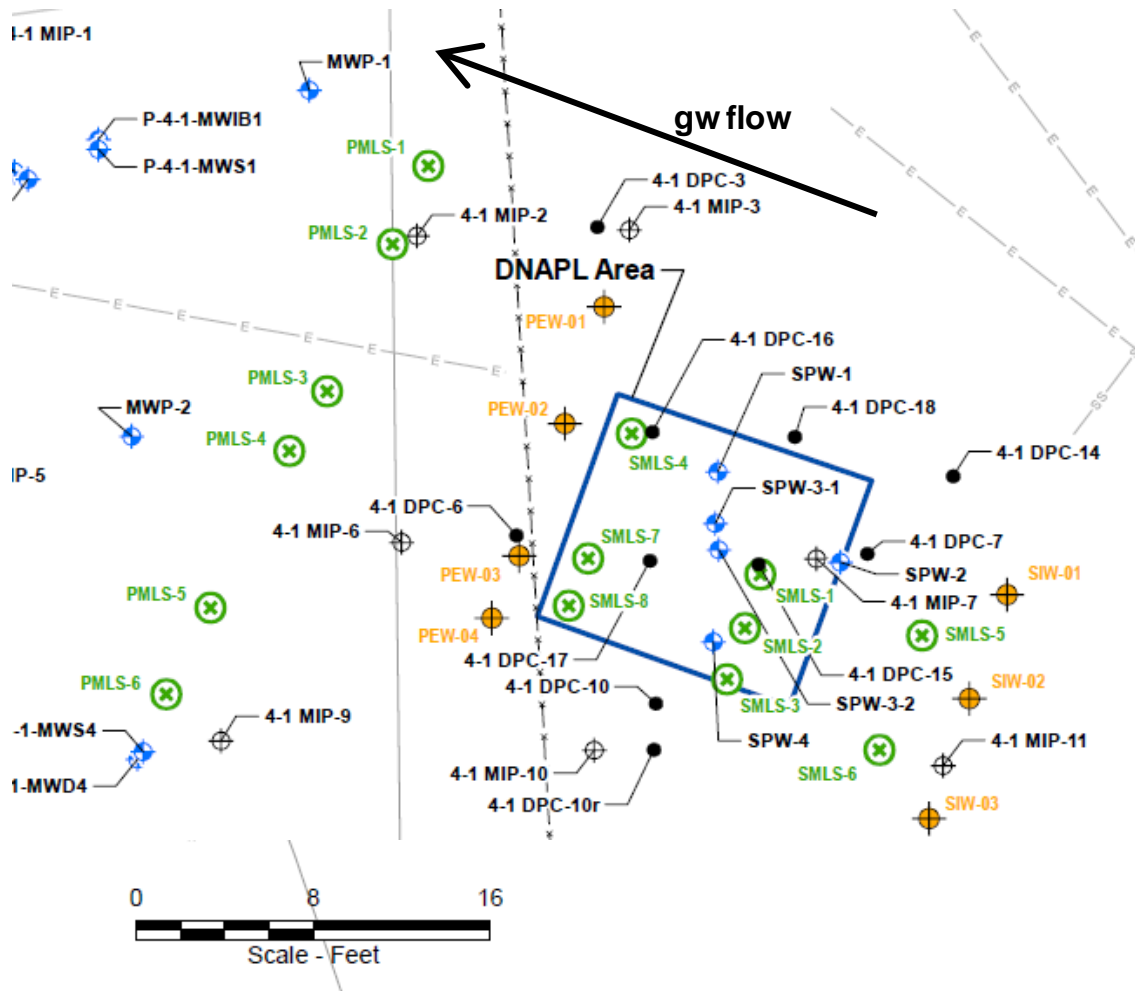

Figure 2.4 Site Layout for the DNAPL Source Area at Alameda Point

The blue box indicates the approximate location of the DNAPL sources. There are three transects of source area multilevel sampling (SMLS) wells, each well providing seven discrete sampling intervals. There is also one transect of plume multilevel sampling (PMLS) wells, each well also providing seven discrete sampling intervals, to monitor the downgradient plume. Injection wells (SIW) and extraction wells (PEW), with piping and other components connecting them, are used to facilitate tracer and dissolution testing.

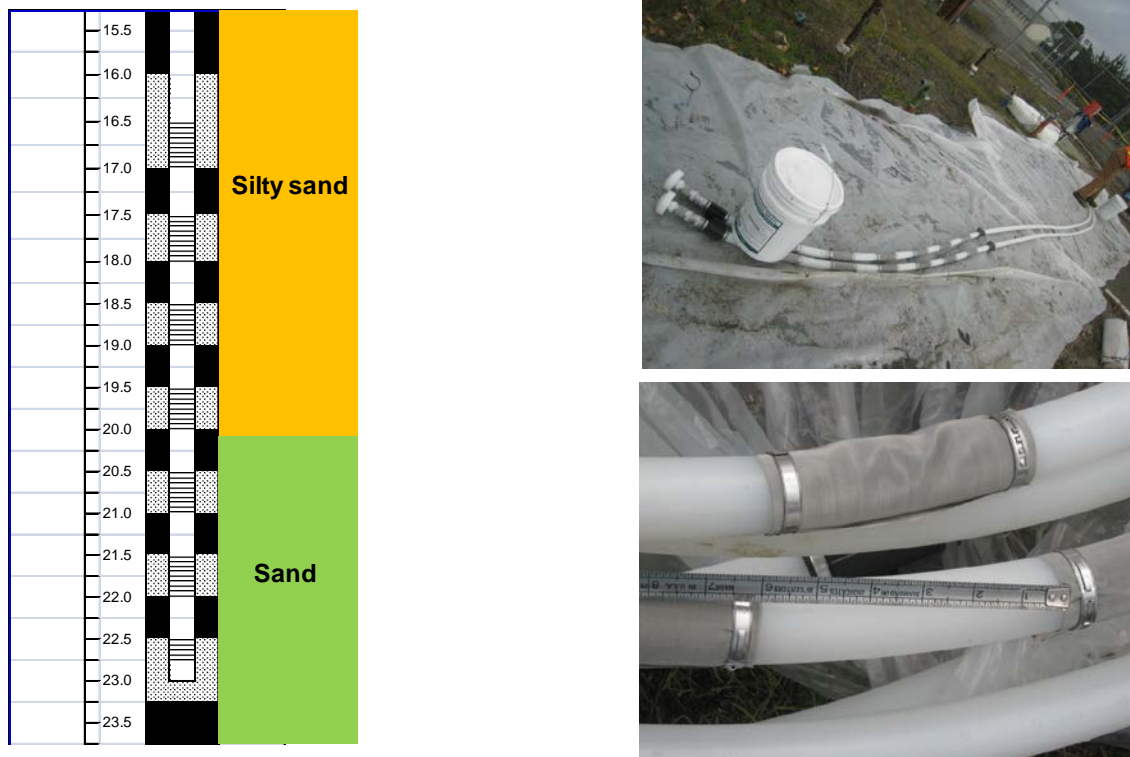

Figure 2.5 MLS Wells

MLS wells are shown on the right, where approximately 6 inches separated each 6-inch screen interval. The figure on the left shows the MLS screens relative to the geology.

PFM tests and PTTs were performed after the investigation and well installation described in the above paragraph was completed. PFM results showed that the TCE mass discharge emanating from the source area was 2.3 g/day. Partitioning tracer testing showed that the groundwater velocity through the lower permeability silty sand was approximately 3 to 4-times less than through the underlying sandy zone. In addition, substantial retardation of the hydrophobic tracers was observed in the silty sand zone where TCE DNAPL was present, consistent with the presence of residual TCE DNAPL in this zone. By comparison, much less hydrophobic tracer retardation was observed in the high permeability zone, suggesting DNAPL was absent or minimally present in this zone (Figure 2.6). The TCE DNAPL mass present in the high permeability zone prior to implementing bioaugmentation was approximately 15 kg, although another 58 to 150 kg of DNAPL may be present in the low permeability zone (Wang et al., 2014).

Evidence for Mass Transfer Controlled Dissolution

- Partitioning tracer behavior in low vs. high flow zones
- No retardation of hydrophobic alcohols in the high flow zone suggests poor contact with DNAPL sources
- Significant retardation of hydrophobic alcohols in the low flow zone, suggest DNAPL is present

Mass transfer limitations likely will be a significant issue controlling source longevity and in limiting remedial effectiveness

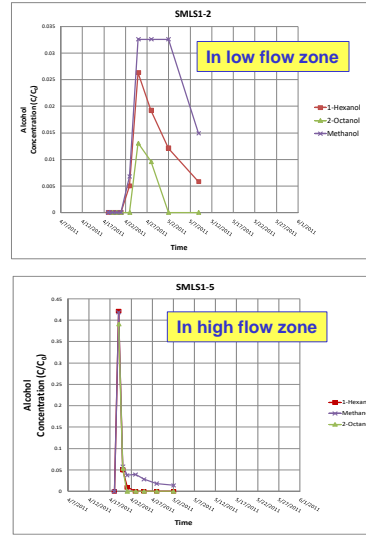

Figure 2.6 Comparison of PTT Results

Comparison of partitioning tracer test results as observed from MLS well location screened in low permeability and high permeability zones. DNAPL sources were present in the low flow zone, associated with the silty sand material (see Figure 2.3).

Based on the investigation and testing described in the previous paragraphs, the simplified conceptual model for the DNAPL source area is shown in Figure 2.7, where the DNAPL is present in the low permeability material. The conceptual model and DNAPL distribution shown in Figures 2.7 and 2.8 are typical of many DNAPL source areas, where DNAPL sources persist in lower permeability materials. For example, as shown in Figure 2.8, other published DNAPL investigations have shown similar DNAPL distributions, where residual DNAPL sources persist in a lower permeable zone adjacent to a higher permeable zone. Thus, careful and intensive assessment of the DNAPL source area at Alameda is expected to provide insight into a large number of DoD sites where DNAPL sources persist.

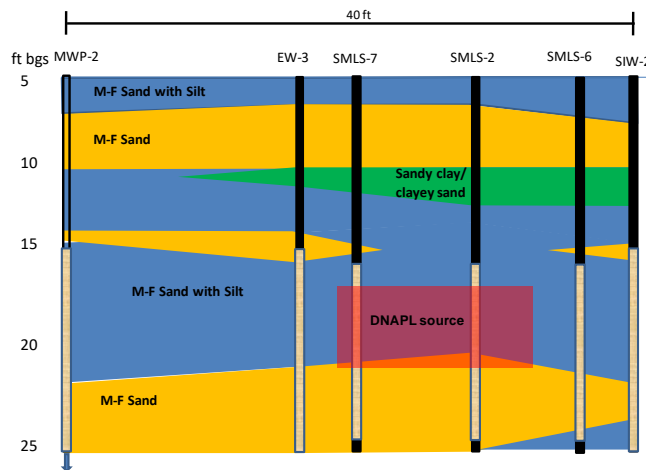

Figure 2.7 Conceptual Geologic Cross Section of DNAPL Source Area

Cross section well points are shown in Figure 2.4.

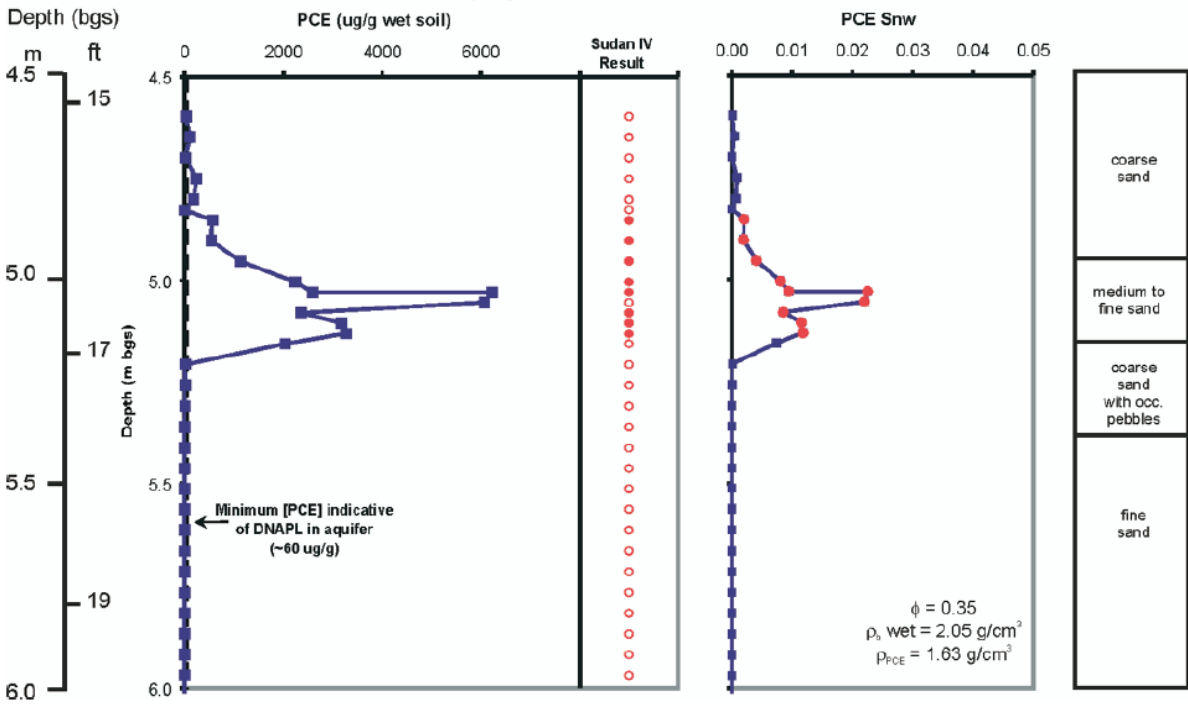
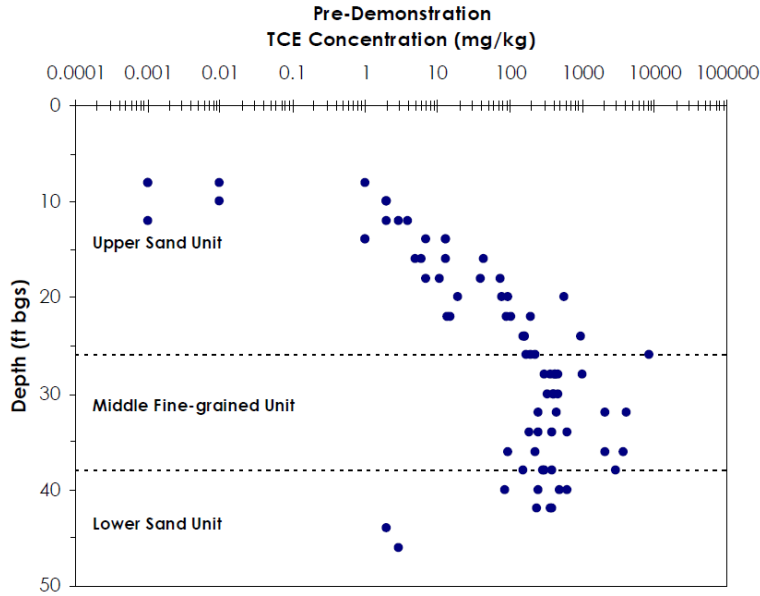

Figure 2.8 Examples of DNAPL Source Areas where Residual DNAPL Sources Reside and Persist in Lower Permeability Zones

*Top – A DNAPL source area at Cape Canaveral (USEPA, 2004).
 Bottom – A DNAPL site in New Hampshire (Parker et al., 2003).*

Following the DNAPL and flow field characterization, bioaugmentation, consisting of intermittent delivery of lactate, nutrients, was performed in the fall of 2012. Bioaugmentation was performed using APTIM's commercially available bioaugmentation culture SDC-9, which contains DHC. Active remediation, during which groundwater was re-circulated and electron donor and nutrients were delivered, occurred for a period of 9 weeks.

Bioaugmentation results observed for an extraction well and an MLS well monitoring location are provided in Figure 2.9 below. It is noted that the extraction wells represent concentrations in the permeable sandy layer (and are representative of measurements collected in typical monitoring wells with 5 to 10-foot screen lengths), while the MLS monitoring point shown in Figure 2.1 is screened within the lower permeability material. For both locations, substantial decreases in TCE and DCE were observed, and ethene was generated, indicating that the complete reductive dechlorination of TCE and DCE was occurring. Chlorinated ethene levels in groundwater decreased in all locations, with an average observed decrease (extraction and MLS wells) of 73%. At the 4 extraction wells, the decrease in chlorinated ethene levels was reasonably accounted for (37% to 80%) on a molar basis based by the observed increases in ethene. Increases in DHC levels were observed at all locations and suggests that remedial amendments were impacting both the low and high permeability zones.

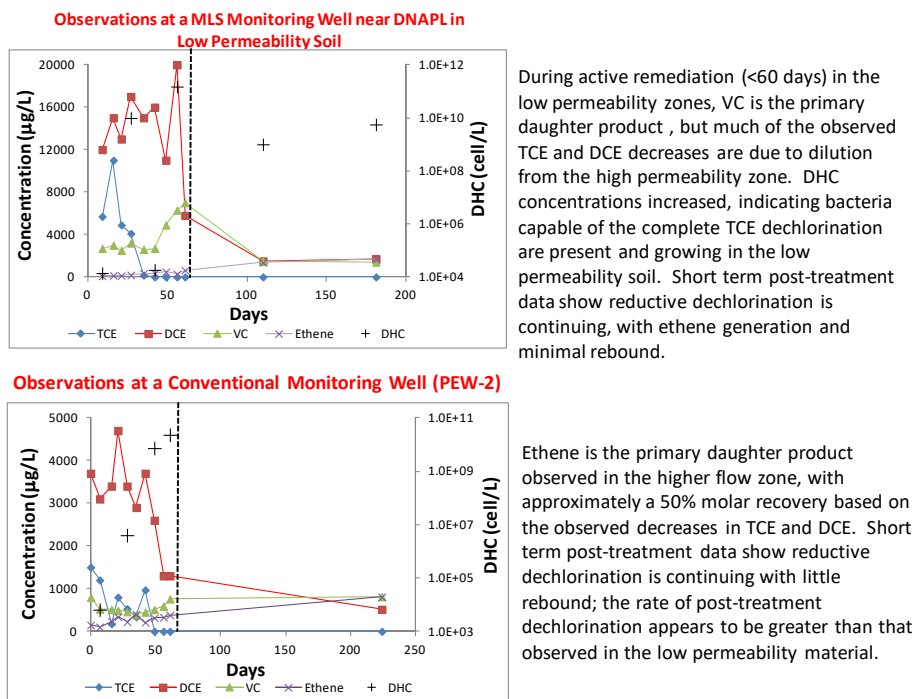

Figure 2.9 Chlorinated Ethene, Ethene, and DHC Results

Chlorinated ethene, ethene, and DHC results measured at an MLS location (screened in the low permeability zone) is shown in the top figure, and at an extraction well (conventional well screen) in the bottom figure. The vertical dashed line shows when active remediation/groundwater recirculation ceased.

The limited post-treatment monitoring performed shows that strongly reducing conditions have persisted, and that reductive dechlorination continues to occur (at least in most locations). Contaminant rebound has been limited, but it is unclear if the observed lack of rebound is due to DNAPL mass removal, the persistence of reductive dechlorination, or both. Mass balance calculations suggest that only about 1% of the DNAPL mass was converted to ethene, suggesting that much of the DNAPL mass is still residing in the lower permeability material. However, the remaining DNAPL mass may be in sufficiently low permeability material that its impact to groundwater may be minimal. Alternately, the continuing biotic, or even iron sulfide facilitated abiotic, reactions may be masking contaminant rebound. Another possibility is that the levels of ethene generation (and chlorinated ethene removal) are being masked by processes such as back-diffusion into the DNAPL (Schaefer et al., 2010; Torlapati et al., 2012), oxidation of ethene by low levels of oxygen persisting in the system, and/or by incomplete capture by the groundwater recirculation system allowing ethene to migrate away from the treatment zone. It also is possible that the DNAPL mass was overestimated due to the presence of hydrocarbon NAPL, and that most of the DNAPL mass has been removed.

2.2.2.1 Questions Regarding Long-Term Treatment Effectiveness in the DNAPL Source Area

Several key questions remain regarding the long-term treatment effectiveness within the Plume 4-1 DNAPL source area. These key questions, the proposed approach to address these questions, and the relevance to other DoD sites with DNAPL source area are summarized in Table 2.1 below:

The questions posed in Table 2.1 require a detailed understanding of the flow field, hydrogeology, and DNAPL distribution associated with the source area, both before, during and after active treatment. By obtaining an improved understanding of the fundamental processes that dictate the answers to these questions, the insight obtained from this highly characterized and instrumented site can be applied to other DNAPL source areas. To the best of our knowledge, such detailed characterization of a heterogeneous DNAPL source area before, during, and after bioaugmentation has not been performed.

Table 2.1 Key Questions, the Approach for Answering the Questions, and Relevance to Other DoD DNAPL Source Areas.

| Key Question for Alameda Source Area | Long Term Monitoring Approach | Fundamental Insight Applicable to Other Sites |
|---|---|--|
| How effective was bioaugmentation for DNAPL mass removal in the lower permeability materials? | <ul style="list-style-type: none"> • Assess groundwater quality in low permeability MLS wells • PTT and soil cores to determine mass of DNAPL removed | <ul style="list-style-type: none"> • Determine extent to which DNAPL in lower permeability media can be treated • Determine expected rate of DNAPL removal in lower permeability media |
| What performance monitoring data during and immediately after active treatment are most useful for assessing long term behavior? | <ul style="list-style-type: none"> • Compare data collected during treatment to the long-term monitoring data • Compare short term rebound data to long term rebound data | Provide a basis for determining the extent of monitoring that is needed, and provide improved insight into long term performance |
| What is the expected duration for which dechlorination will persist following active treatment (biotic and abiotic processes), and how do they compare to rates observed during active treatment? | <ul style="list-style-type: none"> • Use long term monitoring to determine rate and extent of dechlorination • Evaluate biogeochemical data and daughter products to determine dechlorination processes | Identify the processes and rates of long term dechlorination following active remediation and use site specific data to evaluate potential impacts at other DoD sites. |
| What tools were most useful? | Evaluate all investigation and remedial data to identify the key information used for design and assessment | Identify tools that are most important for assessing and remediating DNAPL source areas |
| What are the long term geochemical and microbial impacts in a DNAPL source zone following bioaugmentation? | <ul style="list-style-type: none"> • Collect long term geochemical data • Evaluate microbial community long term | Understand long term aquifer response to bioaugmentation, and potential for long term secondary impacts, whether beneficial or adverse |
| What are the near downgradient impacts resulting from bioaugmentation in the DNAPL source area? | Perform long term monitoring at downgradient MLS transect to assess changes in flux, groundwater quality and DHC migration | Understand the relationship between source area treatment and downgradient response, and determine extent to which treatment may occur downgradient |
| How did DNAPL mass removal and groundwater quality correlate, and what level of treatment (e.g., MCLs?) is attainable? | Use PTT and soil cores to determine mass of DNAPL removed, and measure (long term) concentrations and flux in groundwater for both the low and high permeability zones | Determine the relationship between DNAPL mass removal and decrease in contaminant flux/groundwater concentrations in a dual permeability system during bioremediation |

2.2.3 Overall Approach for the Long-Term Performance Assessment

We propose to take advantage of this highly characterized DNAPL demonstration site (Figure 2.4) at Alameda to perform a long-term (starting at 2 years following cessation of active treatment, with monitoring continuing as part of this proposed project through 4 years post-treatment) detailed assessment of bioaugmentation performance. With the source area and downgradient MLS transects still in place, there is a unique opportunity to perform an intensive long-term post treatment evaluation to assess contaminant rebound, extended treatment due to exogenous biomass decay, contaminant flux, geochemical conditions, and microbial communities within and downgradient of the source area.

Three rounds of groundwater monitoring from up to 106 monitoring locations will be performed during the proposed 2-year duration of this project, thereby allowing for observation in long term trends following treatment with respect to dechlorination rates, geochemistry, groundwater quality, and microbial community. This assessment will include monitoring at wells immediately downgradient of the treated DNAPL source area, which will be used to assess treatment, biogeochemical impacts, DHC migration, and microbial community shifts on the near downgradient plume long term.

In addition, using the existing well network, PFMs will be deployed to measure flux both within and downgradient of the source area. PFM data collected prior to bioaugmentation (as part of SERDP Project ER-1613) will be used to provide a direct measure of the contaminant flux reduction resulting from bioaugmentation treatment. PTT and soil sampling also will be performed and compared to pre-treatment results (Wang et al., 2014) to determine the extent of DNAPL mass removal, and to further evaluate the relationship between DNAPL mass removal, groundwater quality in high and low permeability zones, and contaminant flux.

2.3 ADVANTAGES AND LIMITATIONS OF THE TECHNOLOGY

2.3.1 Advantages

The primary advantages of performing the proposed long-term assessment approach are as follows:

1. The long-term performance of bioaugmentation in a DNAPL source area will be determined for a highly characterized site;
2. Processes contributing to the long-term dechlorination of TCE will be investigated;
3. Long-term impacts on groundwater biogeochemistry will be quantified; and
4. The tools and characterization activities most crucial for project success will be identified.

In addition, by performing this demonstration at a site that has undergone extensive characterization (Wang et al., 2014), with a high density of multi-level sampling wells, we anticipate that very detailed insight into bioaugmentation and DNAPL dissolution processes will be attained.

2.3.2 Limitations

As with all technologies and assessment approaches, there are also limitations with the proposed approach:

1. The assessment is being performed at a single site. Although this site is highly characterized and well-instrumented, which is expected to provide unique and useful results, it is only one site;
2. The rate of change on groundwater biogeochemical properties, as well as chlorinated ethene concentrations, may be slow relatively to the proposed duration of this project. Options for extending the sampling timeframe for the project may need to be considered; and

Accumulated biomass from the bioaugmentation may interfere with the proposed partitioning tracer test, which will be used to estimate DNAPL mass. A column test will be performed prior to the field tracer test to assess this potential complication. In addition, alternative methods of estimating DNAPL mass (e.g., soil core collection) will be performed as a means to estimate DNAPL mass.

Page Intentionally Left Blank

3.0 PERFORMANCE OBJECTIVES

Performance objectives are summarized in Table 3.1, and details are provided in Sections 3.1 through 3.4.

Table 3.1 Performance Objectives

| Performance Objective | Data Requirements | Success Criteria | Results |
|--|---|---|---|
| Quantitative Performance Objectives | | | |
| Assess effectiveness of DNAPL mass removal in low permeability materials | Groundwater TCE levels, soil samples (pre and post treatment), and partitioning tracer data | Groundwater TCE concentrations <1% solubility, TCE soil concentrations <100 µg/kg, and no measureable retardation during partitioning tracer test | DNAPL was removed in part of the source area, but not all. |
| Assess the long-term dechlorination activity (biotic/abiotic) following active remediation | Measured daughter products (DCE, VC, ethene/ethane/acetylene, chloride) and <i>Dehalococcoides</i> levels | Daughter product generation greater than baseline levels | Enhanced reductive dechlorination is continuing at the site |
| Determine downgradient impacts | VOC, reduced gas, and biogeochemical parameters at downgradient transect from the treatment area. Also, contaminant mass flux from the source area. | >20% reduction in VOC concentrations downgradient, or >50% reduction in mass flux emanating from the source area. | Plume monitoring locations indicate >50% decrease |
| Qualitative Performance Objectives | | | |
| Identify characterization and monitoring tools that were most critical for designing and assessing treatment | Assess information from tracer tests, discrete interval sampling, MIP and soil investigations, hydraulic profiling tool | Determine how collected data contributed to conceptual model and performance assessment | Discrete interval sampling, MIP, and HPT were highly useful |

3.1 ASSESS EFFECTIVENESS OF DNAPL MASS REMOVAL IN LOW PERMEABILITY MATERIALS

One of the primary objectives of this demonstration is to assess the long-term of effectiveness of applying bioaugmentation to treat DNAPL sources. Understanding the extent to which DNAPL mass has been removed, and the subsequent impact on groundwater quality, is critical in this evaluation.

3.1.1 Data Requirements for DNAPL Removal

Groundwater TCE concentrations, TCE soil concentrations attained through post-treatment soil core collection, and partitioning tracer testing will all be used to provide an assessment of DNAPL mass removal.

3.1.2 Success Criteria for DNAPL Removal

Groundwater TCE concentrations <1% solubility, TCE soil concentrations <100 µg/kg, and no measureable retardation during partitioning tracer test all can serve as indicators to confirm the absence of DNAPL. However, the relationship among the fraction of DNAPL mass removed (determined by comparing pre- and post-treatment data), improvement in groundwater quality, and active treatment time will be assessed to evaluate the overall effectiveness of bioaugmentation for treating DNAPL source areas.

3.2 ASSESS THE LONG-TERM DECHLORINATION ACTIVITY (BIOTIC/ABIOTIC) FOLLOWING ACTIVE REMEDIATION

Dechlorination activity following active bioremediation (i.e., when electron donor addition and groundwater re-circulation were occurring) can occur due to both biotic and abiotic processes. These processes can provide a remedial benefit. Improved understanding of these long term processes likely will lead to improved treatment design and management.

3.2.1 Data Requirements for assessing long-term dechlorination activity

Generation of chlorinated ethene daughter products, ethene/ethane/acetylene, and chloride all serve as indicators of continuing dechlorination activity. Elevated *Dehalococcoides* sp. (DHC) levels in groundwater also can serve as an indicator of continuing dechlorination activity.

3.2.2 Success Criteria for assessing long-term dechlorination activity

Daughter products and DHC levels will be compared to baseline (pre-treatment) levels to determine the extent to which enhanced dechlorination is occurring.

3.3 DETERMINE DOWNGRADIENT IMPACTS

The extent to which treatment within the source area impacts the downgradient plume is important for assessing the overall success of a remedial approach.

3.3.1 Data Requirements for determining downgradient impacts

Decreases in groundwater TCE concentrations will be the primary metric used to assess downgradient impacts. However, migration of DHC and changes in biogeochemical conditions also will be evaluated. Decreases in flux emanating from the source area also will be used as a metric.

3.3.2 Success Criteria for determining downgradient impacts

Reduction in volatile organic compound (VOC) levels >20% from baseline levels, or >50% reduction in TCE mass flux emanating from the source area, would provide a strong indication of beneficial impacts on the downgradient plume.

3.4 IDENTIFY CHARACTERIZATION AND MONITORING TOOLS THAT WERE MOST CRITICAL FOR DESIGNING AND ASSESSING TREATMENT

Substantial characterization and monitoring effort has or will be performed for the Alameda Plume 4-1 DNAPL source area. Identifying the tools that were most useful for designing, implementing, and evaluating treatment will be useful for optimizing treatment at other sites.

3.4.1 Data requirements to identify characterization and monitoring tools that were most critical for designing and assessing treatment

All the tools and techniques used during the characterization and monitoring (during and post treatment) will be included. This includes soil sampling, MIP, HPT, discrete interval groundwater sampling, PFMs, PTTs, and use of monitoring well transects.

3.4.2 Success criteria to identify characterization and monitoring tools that were most critical for designing and assessing treatment

The success criteria are qualitative but will be based on the level-of-effort and benefit/insight attained from implementing the various tools and techniques at the site.

Page Intentionally Left Blank

4.0 SITE DESCRIPTION

4.1 SITE SELECTION

This project was conceived based on performing long term post-bioaugmentation monitoring in the Plume 4-1 DNAPL source area at Alameda Point, CA. This site has been highly characterized (Wang et al., 2014), and effective treatment of chlorinated ethenes was shown to occur during and immediately after bioaugmentation. The high-resolution discrete interval monitoring network that is still emplaced at Alameda provides a unique opportunity to study this site. In addition, APTIM has an office in close proximity to this site.

The selection criteria that were evaluated with respect to Alameda are provided in Table 4.1 below.

Table 4.1 Site Selection Criteria

| Parameter | Preferred Value(s) | Relative Importance (1-5, with 1 being highest) | Alameda |
|---|---------------------------|--|----------------|
| DNAPL initially present | >100 µg/kg | 5 | Yes |
| Shallow depth | < 80 ft | 3 | Yes |
| Absence of mobile DNAPL/LNAPL | NA ¹ | 4 | Yes |
| Highly characterized DNAPL source area | >10 ⁻⁴ ft/day | 5 | Yes |
| Bioaugmentation Implemented | NA ¹ | 5 | Yes |
| Existing monitoring network (high resolution) | NA ¹ | 4 | Yes |
| Site accessibility | NA ¹ | 3 | Yes |
| Location relative to APTIM Offices | <50 miles | 2 | Yes |

¹ Not applicable

4.2 SITE LOCATION AND HISTORY

Alameda Point is located on the northwestern tip of Alameda Island, which is along the eastern margin of the San Francisco Bay and south of the City of Oakland. The northern portion of Alameda Island was formerly tidelands, marshlands, and sloughs adjacent to the historical San Antonio Channel, now known as the Oakland Inner Harbor. Alameda Point was created by filling sub tidal areas, natural tidelands, marshlands, and sloughs with dredge spoils from the surrounding San Francisco Bay, Seaplane Lagoon, and Oakland Inner Harbor. Alameda Point is a roughly rectangular area approximately 2 miles wide from east to west and 1 mile from north to south, occupying approximately 1,734 acres of land.

Installation Restoration (IR) Sites 3, 4, 11, and 21 are designated as OU-2B under the Comprehensive Environmental Response, Compensation, and Liability Act of 1980 and have been the subject of environmental investigations due to historical documentation of fuel, oil, and solvent usage related to bulk fuel service and ship and aircraft maintenance and repair.

IR Site 4 (in which our demonstration area resides) comprises approximately 14 acres, is approximately 65 percent open space, and has infrastructure that includes paved parking lots, storage areas, and a sports field (see Figure 4.1). The site includes Building 360, a former Aircraft Engine Facility that contained process shops for blast testing, cleaning, painting, welding, and plating; various aircraft component repair rooms; and nondestructive testing facilities.

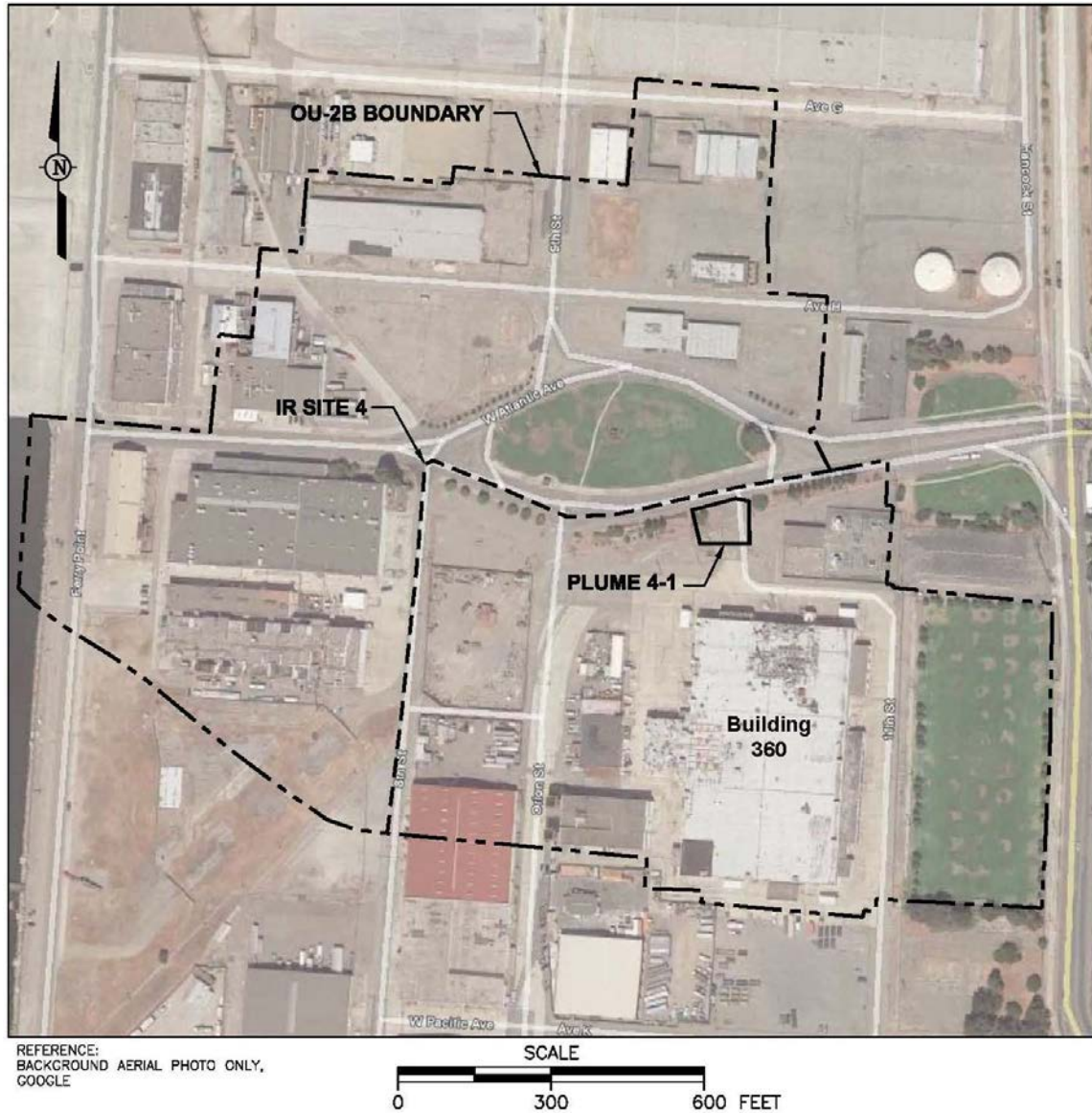

Figure 4.1 Site Location Map

Prior to 1975, wastes generated by plating operations in Building 360 were discharged directly to the Seaplane Lagoon via the industrial waste sewer system. Between 1975 to April 1997, plating wastes were treated at an industrial waste treatment facility located north of Building 360. Chemical contaminants from the various industrial processes inside Building 360 are believed to have been released to the subsurface at IR Site 4 by leaks in the sanitary, industrial waste, and storm sewer lines from the building.

4.3 SITE GEOLOGY AND HYDROGEOLOGY

The stratigraphy beneath Plume 4-1 consists of two geologic units: the Merritt Sand Formation and artificial fill (Tetra Tech Environmental Management, Inc., 1999). The Merritt Sand Formation extends from roughly 10 to 70 feet below ground surface (bgs). It is composed of an orange-brown, fine-grained, silty sand and a fine-grained clayey sand. The top of the Merritt Sand is composed of a dense, well-consolidated, clayey sand, between 1 and 5 feet thick and has a low hydraulic conductivity. Additionally, a contact zone divides the Merritt Sand into an upper eolian and a lower alluvial section. The eolian section of the Merritt Sand represents sediment deposition by airborne processes, and the alluvial section of the Merritt Sand represents sediment deposition by fluvial or water processes. The contact zone between the eolian sand and alluvial sand sections ranges from 5 to 15 feet thick, consisting of a dense to well-consolidated clayey sand. This clayey sand has a low hydraulic conductivity.

Overlying the Merritt Sand Formation is the artificial fill that extends from the surface down to 10 feet bgs. The artificial fill consists of a light to dark brown, fine-grained, silty sand with trace amounts of gravel and brick fragments. The fill is composed of dredge spoils from the San Francisco Bay and the Oakland Inner Harbor.

Groundwater at Plume 4-1 is first encountered between 2 and 8 feet bgs within the artificial fill. Unlike areas to the west, there is no intervening layer of Bay Sediment between the artificial fill and Merritt Sand beneath Plume 4-1; therefore, the first water-bearing zone behaves as a single hydro geologic unit. The groundwater flow directions are affected by local recharge from precipitation, seasonal variation in groundwater elevations, and tidal influences. For Alameda Point, the groundwater has been found to generally flow from southeast to northwest.

4.4 CONTAMINANT SOURCE AND DISTRIBUTION

Historic groundwater data for Plume 4-1 suggested that a chlorinated ethene source was presented at the upgradient edge of the plume, as shown in Figure 4.2. Based on measured TCE concentrations well in excess of 1% of the aqueous solubility, there was a strong potential for the presence of TCE DNAPL within the source area.

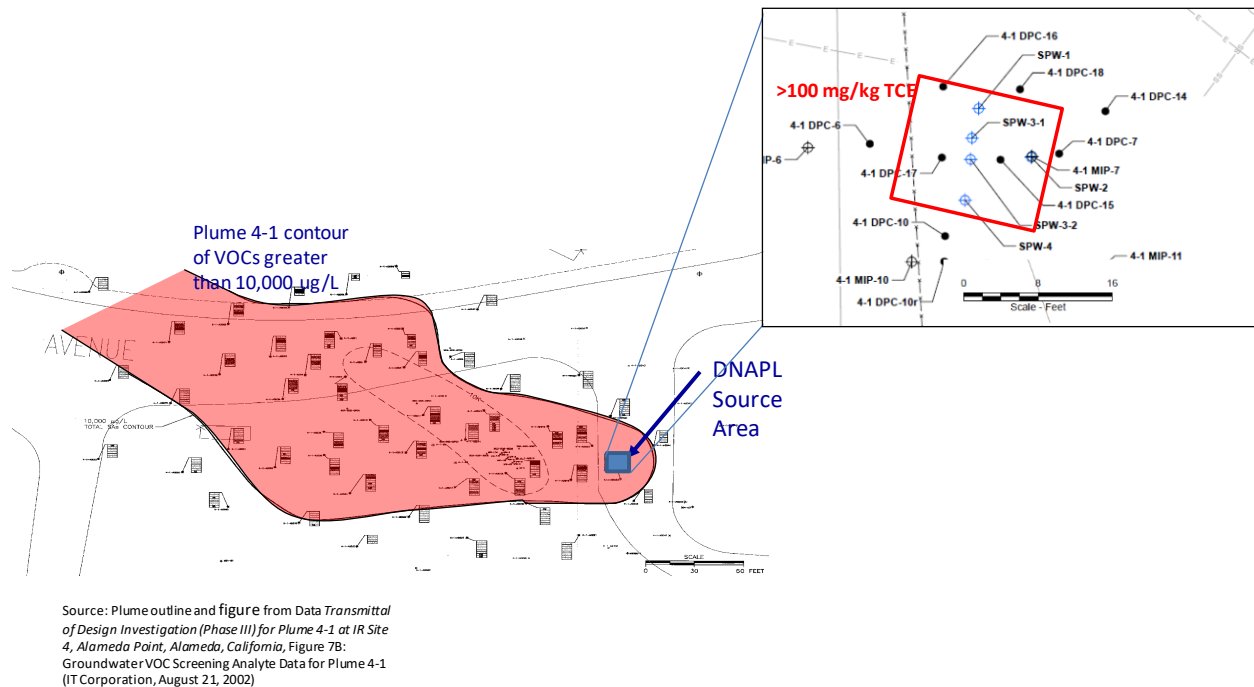

Figure 4.2 Plume 4-1 TCE Contour

The area identified as the DANPL source area also is highlighted.

Initial characterization activities were performed (beginning in the spring of 2010) to determine the approximate location and extent of the potential DNAPL source area. A combination of investigation tools was applied, including membrane interface probes, soil boring with soil sampling for VOCs, and a hydraulic profiling tool to obtain a high-resolution vertical profile of the permeability field. Installation of transect of multi-level sampling wells was performed, as well as performance of a partitioning tracer test. This work, as previously described in Wang et al. (2014) and summarized in Section 2.1.4, provided a detailed analysis of the DNAPL mass and distribution.

4.5 TEST PLOT LOCATION

The long-term assessment demonstration test plot is located at the Plume 4-1 source area, as discussed in Section 2.2.2 and shown on Figure 2.4 and is situated near the corner of West Atlantic Avenue and Skyhawk Street. The plot is adjacent to the northwest corner of Building 360, as shown on Figure 4.1. The dimensions of the suspected DNAPL source area are approximately 12 ft by 10 ft (see the blue box in Figure 2.4); while the overall test plot (between the upgradient injection wells SIW-01 through SIW-03 and the downgradient PMLS wells) is approximately 40 ft x 40 ft.

5.0 TEST DESIGN

The following subsections provide detailed descriptions of the system design and testing conducted to address the performance objectives described in Section 3.0.

5.1 CONCEPTUAL EXPERIMENTAL DESIGN

This project focused on performing intensive groundwater and soil monitoring following previous bioaugmentation treatment of a TCE DNAPL source area. Monitoring activities included the following:

- 3 rounds of groundwater sampling (including several MLS wells) over a 2-year period. VOCs, geochemical parameters, CSIA, and microbial parameters were all included in this monitoring program.
- Soil cores were collected within the DNAPL source area to determine the extent to which DNAPL sources had been treated.
- PFMs were used to determine the change in TCE flux before and after bioaugmentation treatment (PFMs were previously deployed at the site, prior to implementing bioaugmentation).
- A partitioning tracer test was performed at the end of the study to provide an estimate of the DNAPL mass remaining. The DNAPL mass estimate was then compared to the DNAPL mass estimate and partitioning tracer results attained prior to bioaugmentation (Wang et al., 2014).

5.2 BASELINE CHARACTERIZATION ACTIVITIES

Extensive characterization of the Plume 4-1 source area at Alameda had previously been performed. This characterization, and the conceptual model developed for the site, are presented in Wang et al. (2014) and summarized in Section 2.2.2. Additional baseline characterization activities were not planned for this project. However, as described in subsequent sections, intensive sampling, monitoring, and characterization activities were planned using the existing monitoring network. These activities were used to assess the long-term impacts, with respect to the treatment of DNAPL sources and groundwater biogeochemistry, following bioaugmentation.

5.3 DESIGN AND LAYOUT OF TECHNOLOGY COMPONENTS

The demonstration area for the proposed long-term performance assessment was previously instrumented with MLS wells, and injection/extraction wells. Because the MLS wells serve as an integral part of this demonstration, a description of their design is included in this section. The tanks, piping, and pumps that were used for the initial partitioning tracer testing (which employed groundwater recirculation within the DNAPL source area) had been previously dismantled but were re-installed for this demonstration. Thus, this section also includes a description of the re-installation of the components needed for the planned partitioning tracer testing/groundwater recirculation.

5.3.1 MLS Well Installation

The MLS wells (see Figure 2.4), both within the DNAPL source area and immediately downgradient of the DNAPL source area, were installed in 2011. The original intent of these wells was to facilitate the DNAPL zone characterization, and to facilitate the assessment of bioaugmentation during the active remediation phase (i.e., when amendments were being delivered and when groundwater was being recirculated).

The MLS wells were constructed using the Solinst CMT Multilevel System. The system utilized the CMT 7 channel system that allowed the installation of 7 discrete sampling intervals within a single well bore. The well construction details are provided Figure 5.1. MLS wells were installed using 8-inch hollow stem augers. The pre-assembled MLS well components (see Figure 2.5) were then inserted through the hollow stem augers to the desired depths. A tremie pipe was used to deliver the sand pack and intervening bentonite seals, as the hollow stem augers were carefully retracted.

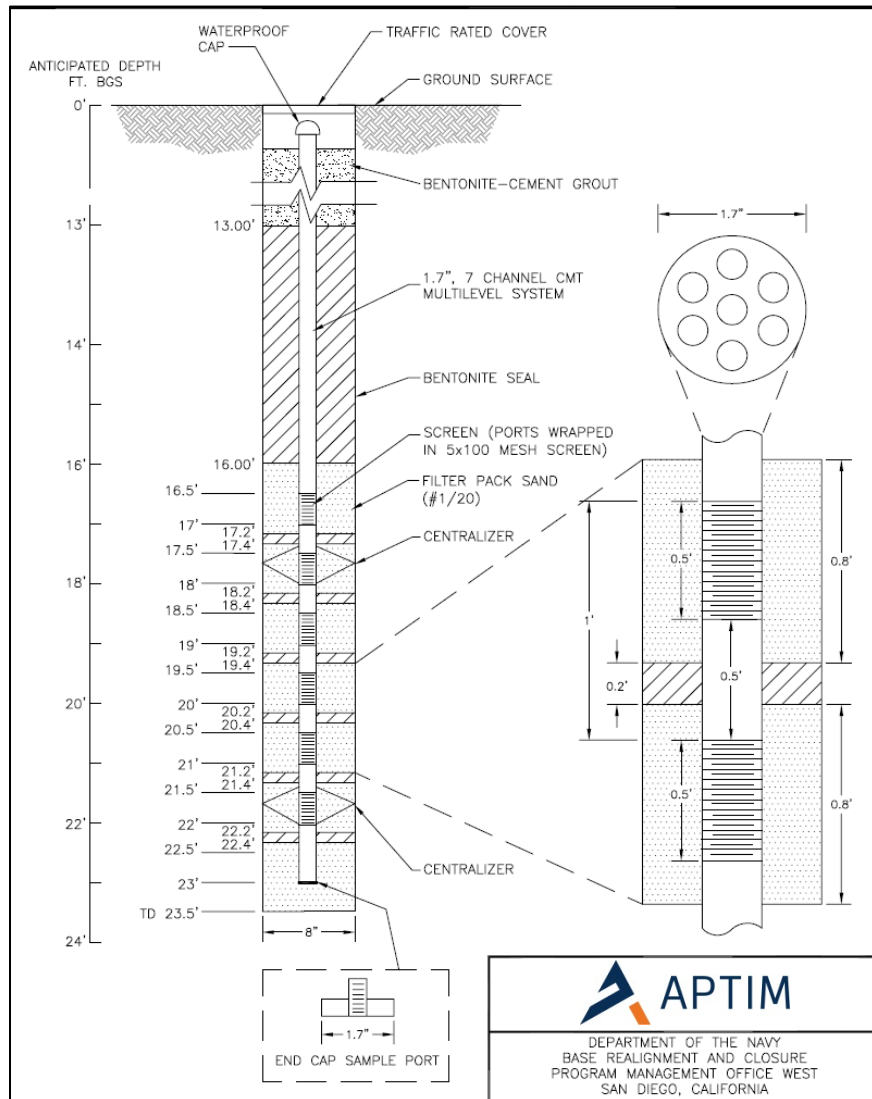

Figure 5.1 MLS Well Construction Details

5.3.2 Groundwater Recirculation System for Implementing the Partitioning Tracer Test

Using the injection and extraction wells shown in Figure 2.4, groundwater recirculation was previously (July 2012 to June 2013) used to measure DNAPL dissolution, perform the initial partitioning tracer test (prior to bioaugmentation), and deliver bioremediation amendments (i.e., bacteria and electron donor) (Shaw, 2013). Following cessation of bioremediation amendment addition and groundwater recirculation, the tanks, pumps, piping and other components associated with the groundwater recirculation system was dismantled. A similar system was re-assembled for this project's partitioning tracer testing (discussed in Section 5.4.4).

Using our previous design as a basis, the groundwater recirculation system consisted of four submersible pneumatic well pumps (3-inch outer diameter Eliminator Pumps, manufactured by QED) installed in each of the four extraction wells (PEW-1 through PEW-4). Extracted groundwater from each extracted well was to be combined into a single pipe prior to filtration and reinjection, as shown in the select photographs presented as Figure 5.2. The components of the system are identified on the piping and instrumentation diagram (P&ID), presented as Figure 5.3. Bag filters were installed to remove any particulates from the process water stream, followed by a pair of granular activated carbon vessels, to remove organic contaminants and alcohol tracers that were extracted. The process water would then be distributed into each of the three injection wells (SIW-1 through SIW-3). The programmable pump controllers (C100M, manufactured by QED) were installed to control the extraction pumps output flow and, in conjunction with in-line flow control valves, to evenly distribute the flow among the three injection wells. Manifold assemblies, made of schedule 80-polyvinyl chloride pipe, were constructed for each of the extraction and injection wells (see photographs presented as Figure 5.2). Wellhead connections, a tracer injection pump, flow meters, valves, pressure gauges, and check valves were also installed.

During the tracer injection phase of the PTT, extracted groundwater was to be diverted so that it passes through the bag and carbon filters, prior to being directed to a holding tank. During this phase, tracer solution was to be injected into the injection wells, instead of the recirculated groundwater. The tracer injection flow was to be set equal to the recirculation flow, and evenly distributed using the same flow control valves employed for the groundwater recirculation. This approach was used in the initial (pre-bioaugmentation) tracer testing (Wang et al., 2014).

5.3.3 Power

Power requirements for system operation were supplied by a 20-kilowatt diesel generator. The two air compressors, supplying compressed air to operate the four pneumatic extraction well pumps, were to be a majority of the electrical consumption during system operation.



Figure 5.2 Groundwater Recirculation and Tracer Delivery System

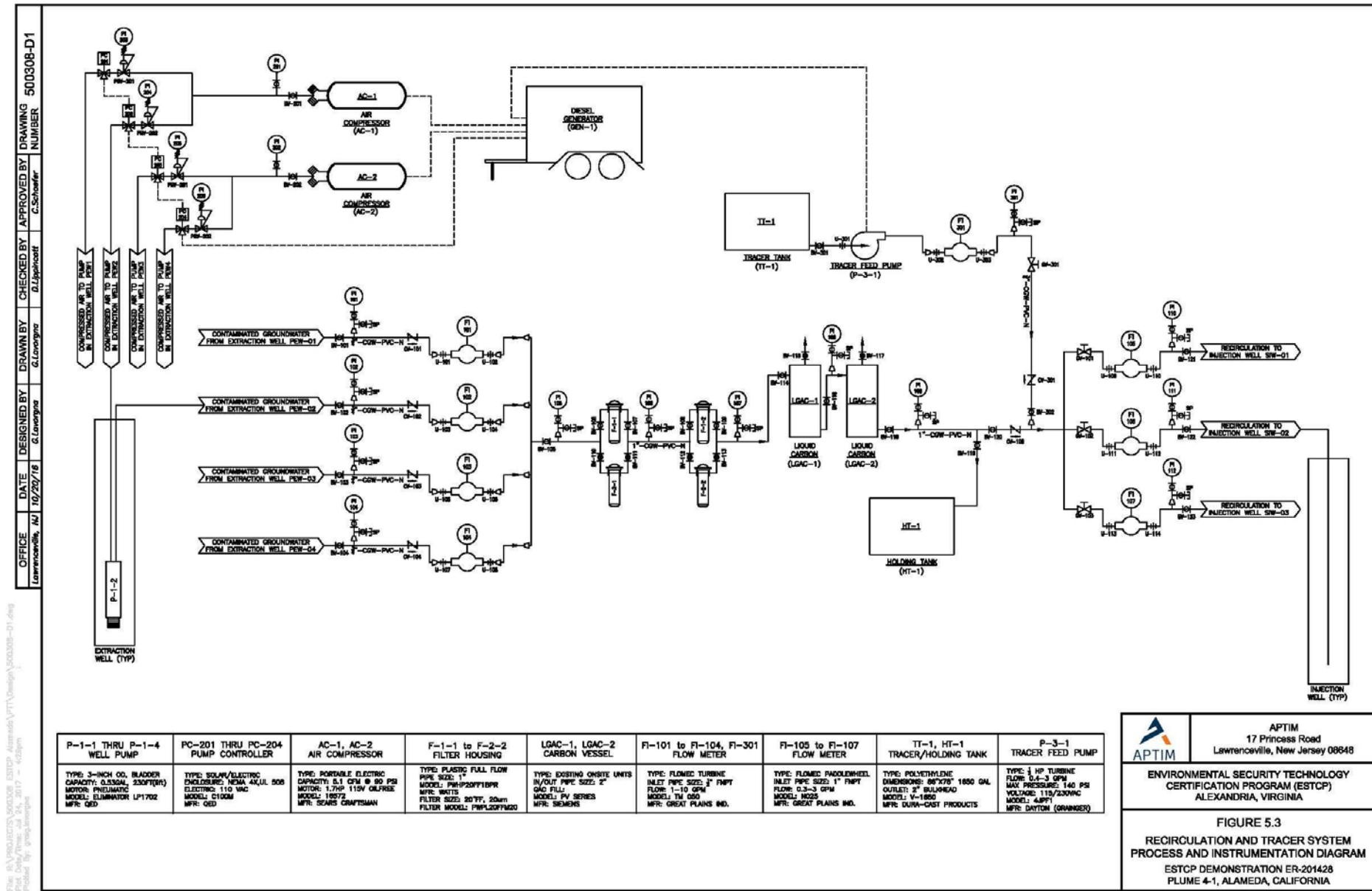

OFFICE DATE DESIGNED BY DRAWN BY CHECKED BY APPROVED BY DRAWING NUMBER
 Lawrenceville, NJ 10/20/16 G.Lavigne G.Lavigne D.Appelhoff C.Schaefer 500308-D1

FILE: R:\PROJECTS\500308_ESTCP_Alameda\PTT\Design\500308-D1.dwg
 Plot Date/Time: Jul 24, 2019 - 4:23pm
 Plotted by: gmg,smg

| | | | | | | | | |
|---|---|--|---|---|---|--|--|--|
| P-1-1 THRU P-1-4 WELL PUMP | PC-201 THRU PC-204 PUMP CONTROLLER | AC-1, AC-2 AIR COMPRESSOR | F-1-1 to F-2-2 FILTER HOUSING | LGAC-1, LGAC-2 CARBON VESSEL | FI-101 to FI-104, FI-301 FLOW METER | FI-105 to FI-107 FLOW METER | TI-1, HT-1 TRACER/HOLDING TANK | P-3-1 TRACER FEED PUMP |
| TYPE: 3-INCH OD, BLADDER CAPACITY: 0.5334, 3300(TBR) MOTOR: PNEUMATIC MODEL: ELIMINATOR LP170Z MFR: GED | TYPE: SOLAR/ELECTRIC CYCLES: NEMA 4X,UL 508 ELECTRIC: 110 VAC MODEL: C100M MFR: GED | TYPE: PORTABLE ELECTRIC CAPACITY: 5.1 CFM @ 90 PSI MOTOR: 1.7HP 115V OLF/PSR MODEL: 18072 MFR: SEARS ROEBUCK | TYPE: PLASTIC FULL FLOW PIPE SIZE: 1" MODEL: PFP20FF18PK MFR: WATTS FILTER SIZE: 20"FF, 20um FILTER MODEL: PFP20FFM20 | TYPE: EXISTING ONSITE UNITS IN/OUT PIPE SIZES: 2" GAC FILL: MODEL: PV SERIES MFR: SICHENS | TYPE: FLOMED TURBINE INLET PIPE SIZE: 2" FNPT FLOW: 1-10 GPM MODEL: TM 040 MFR: GREAT PLAINS IND. | TYPE: FLOMED PADLOMHEEL INLET PIPE SIZES: 1" FNPT FLOW: 0.3-3 GPM MODEL: R025 MFR: GREAT PLAINS IND. | TYPE: POLYETHYLENE DIMENSIONS: 80"x78" 1650 GAL. OUTLET: 2" BULKHEAD MODEL: V-1650 MFR: DURR-GEST PRODUCTS | TYPE: 1/2 HP TURBINE FLOW: 0.4-3 GPM MAX PRESSURE: 140 PSI VOLUME: 115/230VAC MODEL: 4-SP1 MFR: GAYTON (GRANNER) |

APTIM
 17 Princess Road
 Lawrenceville, New Jersey 08648

**ENVIRONMENTAL SECURITY TECHNOLOGY
 CERTIFICATION PROGRAM (ESTCP)
 ALEXANDRIA, VIRGINIA**

**FIGURE 5.3
 RECIRCULATION AND TRACER SYSTEM
 PROCESS AND INSTRUMENTATION DIAGRAM
 ESTCP DEMONSTRATION ER-201428
 PLUME 4-1, ALAMEDA, CALIFORNIA**

Figure 5.3 PTT Recirculation System P&ID

5.4 FIELD TESTING

The demonstration field activities included 1) groundwater sampling, 2) PFM measurements (which will coincide with two of the three groundwater sampling events), 3) soil sampling, and 4) performance of a partitioning tracer test (the final field activity of this demonstration). The timeline of field activities is summarized in the Gantt chart shown in Table 5.1.

Table 5.1 Timeline of Field Operations

| Timeline of Field Operations ESTCP Project ER-201428 | | | | | | | | | | |
|---|--|----------------|---------------------|---------------------|-------------|-------------|-------------|-------------|-------------|-------------|
| ID | Task Name | Duration | Start | Finish | Qtr 1, 2015 | Qtr 2, 2015 | Qtr 3, 2015 | Qtr 4, 2015 | Qtr 1, 2016 | Qtr 2, 2016 |
| 1 | Groundwater Sampling Event No. 1 | 52 days | Mon 3/9/15 | Tue 5/19/15 | | | | | | |
| 2 | Groundwater Sample Collection | 14 days | Mon 3/9/15 | Thu 3/26/15 | | | | | | |
| 3 | Passive Flux Meter Testing | 16 days | Tue 4/28/15 | Tue 5/19/15 | | | | | | |
| 4 | Soil Sampling Event | 5 days | Wed 4/22/15 | Tue 4/28/15 | | | | | | |
| 5 | Pre-clear drilling locations | 1 day | Wed 4/22/15 | Wed 4/22/15 | | | | | | |
| 6 | Soil Core Collection | 2 days | Mon 4/27/15 | Tue 4/28/15 | | | | | | |
| 7 | Groundwater Sampling Event No. 2 | 11 days | Tue 12/1/15 | Tue 12/15/15 | | | | | | |
| 8 | Groundwater Sample Collection | 11 days | Tue 12/1/15 | Tue 12/15/15 | | | | | | |
| 9 | Groundwater Sampling Event No. 3 | 28 days | Mon 8/1/16 | Wed 9/7/16 | | | | | | |
| 10 | Groundwater Sample Collection | 9 days | Mon 8/1/16 | Thu 8/11/16 | | | | | | |
| 11 | Passive Flux Meter Testing | 16 days | Wed 8/17/16 | Wed 9/7/16 | | | | | | |
| 12 | Partitioning Tracer Test Recirculation System | 11 days | Thu 10/13/16 | Thu 10/27/16 | | | | | | |
| 13 | Recirculation System Installation | 6 days | Thu 10/13/16 | Thu 10/20/16 | | | | | | |
| 14 | Recirculation System Testing | 2 days | Wed 10/26/16 | Thu 10/27/16 | | | | | | |
| 15 | Push-Pull Tracer Test | 52 days | Wed 11/9/16 | Thu 1/19/17 | | | | | | |
| 16 | Well Development: SPW3-1 and SPW4 | 2 days | Wed 11/9/16 | Thu 11/10/16 | | | | | | |
| 17 | Push-Pull Tracer Test Implementation | 4 days | Mon 12/5/16 | Thu 12/8/16 | | | | | | |
| 18 | System Decommissioning | 29 days | Mon 12/12/16 | Thu 1/19/17 | | | | | | |

5.4.1 Groundwater Sampling

Three rounds of groundwater sampling were performed. The objective of the groundwater sampling was to assess the long-term impacts of the previously performed bioaugmentation treatment on groundwater quality and biogeochemistry. Monitoring locations upgradient, within, and downgradient of the DNAPL source area were evaluated. All monitoring locations are presented on Figure 5.4. Table 5.2 summarizes the monitoring locations/intervals and the rationale for their inclusion, at least initially, in the groundwater sampling program.

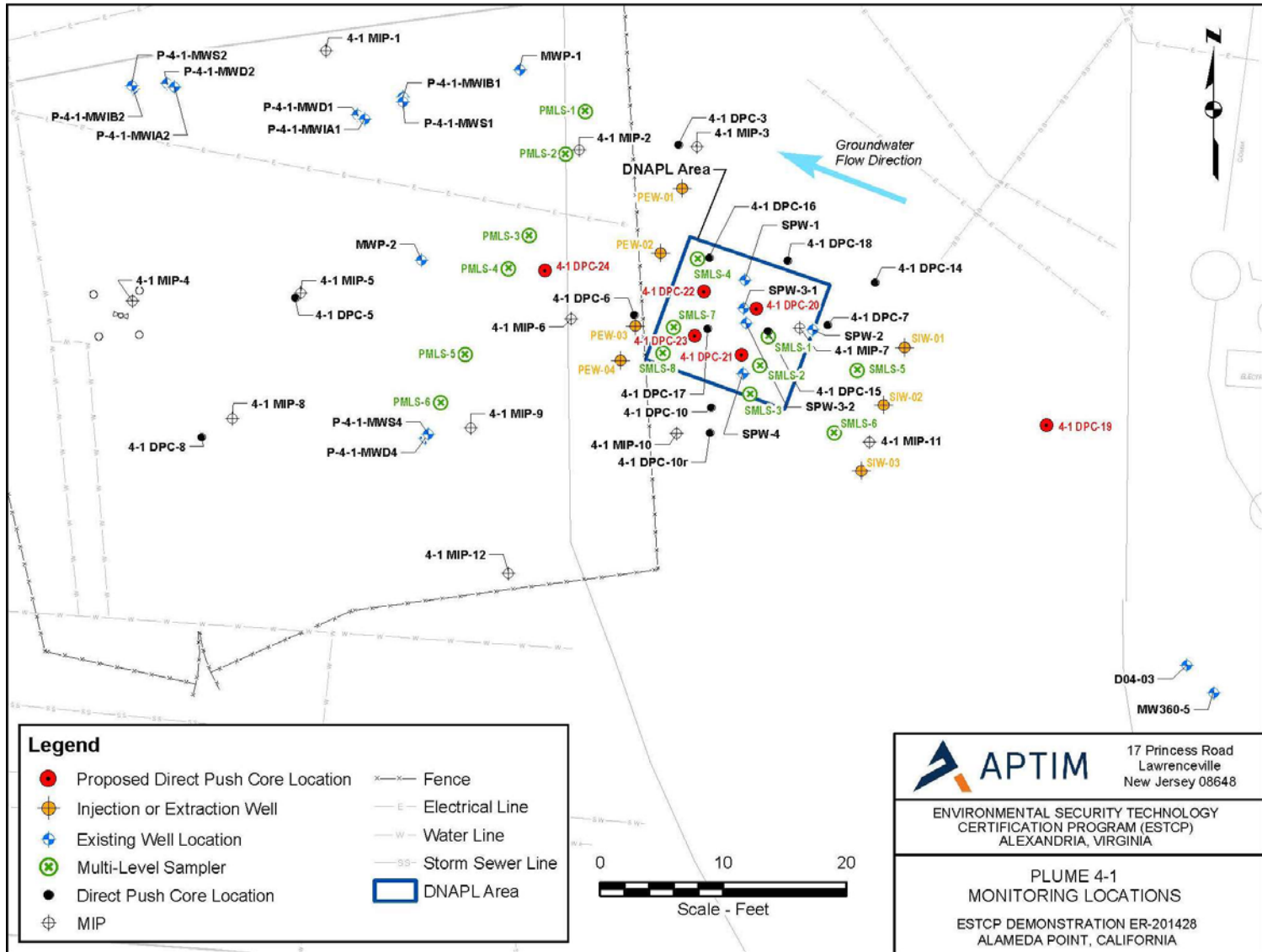

G:\Alameda\GIS_Documents\Project_Maps\Plume4_1\ALA_026_ESTCP.mxd 7/26/2017

Figure 5.4 Plume 4-1 Monitoring Locations

Table 5.2 Groundwater Sampling Locations and Rationale

| Monitoring Location | Screened Interval (ft bgs) | Rationale |
|---------------------|---|---|
| MW360-5 | 9 to 19 | Upgradient from the DNAPL source area and bioremediation zone. This well will serve as a background location. |
| SIW-1 through 3 | 15 to 25 | Immediately upgradient from the DNAPL zone, but within the bioremediation zone |
| SMLS-1 through 8 | 7 discreet 0.5 ft intervals (16.5-17, 17.5-18, 18.5-19, 19.5-20, 20.5-21, 21.5-22, 22.5-23) | Within the DNAPL source zone. The shallowest 4 intervals are generally in the lower permeability material where the elevated DNAPL levels were located. |
| SPW-1 SPW-4 | 17 to 22 | Within the DNAPL source zone; screened across both the lower and higher permeability material. |
| SPW3-1 | 17 to 19.5 | Within the DNAPL source zone; located in the lower permeability material. |
| SPW3-2 | 19.5 to 22 | Within the DNAPL source zone; located in the higher permeability material. |
| PEW-1 through 4 | 15 to 25 | Immediately downgradient of the DNAPL zone, but within the active bioremediation zone |
| PMLS-1 through 6 | 7 discreet intervals (16-18, 19-21, 22-24, 25-27, 28-30, 31-33, 34-35.5) | Transect approximately 15 ft. downgradient of the DNAPL zone. |

As will be discussed in Section 5.6.4, a full set of 106 sample intervals were monitored during the first sampling event, with each of the following two sampling events containing fewer monitoring intervals based on the results of the previous events.

Groundwater sampling included the following parameters at select locations. A summary of the parameters and monitoring locations included during each of the three groundwater sampling events are provided in Sections 5.6.4.1 through 5.6.4.3.

- VOCs. VOCs were used to assess the extent of treatment and/or rebound, and the extent to which reductive dechlorination of the parent TCE may still be occurring.
- Reduced gases. Reduced gases, including ethane, ethane, methane, acetylene and propane, were used to assess the extent to which biogeochemical reactions are still occurring within the treatment area. Methane data also provided insight into the redox conditions.
- Anions. Nitrate and sulfate levels provided insight into the current redox conditions. Chloride levels provided insight into reductive dechlorination processes (in DNAPL source areas, chloride generation may be detectable above background chloride levels).
- Dissolved iron and manganese. Dissolved iron and manganese levels provide insight into redox conditions and may also be useful for interpreting the mechanisms for any observed abiotic reactions.

- Volatile fatty acids. Volatile fatty acids were present during the active bioremediation that was performed. Collected groundwater samples were used to determine if residual levels persist, possibly serving as electron donors.
- Dissolved hydrogen. Dissolved hydrogen levels were used to assess electron donor levels, as well as any potential ongoing fermentation.
- Total Organic Carbon (TOC). TOC levels provide an indication of available carbon that could serve as electron donor.
- Field Parameters. Dissolved oxygen, pH, turbidity, and ORP.
- Microbial Community. Microbial Insights' Chlorinated QuantArray approach was utilized to determine a variety of halorespiring bacteria (*Dehalococcoides*, *Dehalobacter*, *Dehalogenimonas*, etc.) levels; and quantify functional genes involved in aerobic (co)metabolic pathways for biodegradation of chlorinated solvents and competing biological processes. Numbers of total methanogens and sulfate reducers were determined.
- CSIA. CSIA analysis (carbon) was performed for TCE, DCE, and/or VC. CSIA was used at selected groundwater sampling locations as a potential measure of degradation (biotic or abiotic) that occurred or is occurring in different regions of the aquifer (i.e., low permeability zone versus high permeability zone vs. downgradient). CSIA has been used successfully to measure degradation of TCE and other VOCs in groundwater samples from aquifers (e.g., Sherwood-Lollar et al., 2001; Meckenstock et al., 2004; Abe et al., 2009; Thullner et al., 2012; Hatzinger et al., 2013), and was expected to be a valuable *in situ* measure of degradation in this study. Changes in isotopic fractionation over time serve as a valuable tool to assess the extent of ongoing degradation, as use of daughter product generation alone can be difficult for determining biodegradation rates.

While some parameters (e.g., VOCs) were monitored at all sampled locations for each of the three monitoring events, other analyses (e.g., CSIA, microbial community) were performed at select locations. In general, determination of these select locations was based in part on the history of the monitoring location. Representative locations with both elevated (i.e., indicative of DNAPL) and low TCE concentrations are included, and locations showing both substantial and limited dechlorination during active remediation were selected. These select locations were also based on location: upgradient, downgradient, low permeability zone, and high permeability zone.

For the initial round of groundwater sampling, as discussed in Section 5.6.4.1, the following parameters were determined at each of the 106 monitoring locations shown in Table 5.2: VOCs, reduced gases, anions, total/dissolved iron, volatile fatty acids, dissolved hydrogen, and TOC. The need to analyze for all these parameters at each location in the subsequent two rounds of monitoring was assessed upon review of the groundwater data. Field parameters were not determined for any of the MLS wells, as these wells were sampled using a minimum purge volume to limit cross-flow among the intervals (see Section 5.6.1). The selected locations and rationale for microbial community analyses and CSIA for the first groundwater monitoring event are provided in Table 5.3.

Table 5.3 Selected Locations and Rationale for Microbial Analyses and CSIA (First Groundwater Monitoring Event)

Data for the monitoring locations were derived primarily from the Final Treatability Study Report submitted to the US Navy (Shaw, 2013) and Wang et al. (2014).

| Analysis | Location | Rationale |
|-----------------------------|--|---|
| Microbial Community | MW360-5 | Located upgradient of the treatment area – background values |
| | SMLS-5 (int. 1 and 3) | Within treatment area, but just upgradient of DNAPL. Screened in low K_h zone. |
| | SMLS-5 (int. 6) | Within treatment area, but just upgradient of DNAPL. Screened in high K_h zone. |
| CSIA (for TCE, DCE, and VC) | SMLS-1 (int. 1 and 3) SMLS-7 (int. 1 and 3) | Within treatment and DNAPL area. Screened in low K_h zone. |
| | SMLS-1 (int. 6) SMLS-7 (int. 6) | Within treatment and DNAPL area. Screened in high K_h zone. |
| | PEW-2 and PEW-3 | Within treatment area, but just downgradient of DNAPL zone. |
| | PMLS-4 (int. 1 and 5) | Further downgradient of treatment area, with intervals in the low (1) and high (5) K_h zones. |

It is noted that Table 5.3 above was intended for the first groundwater monitoring round. The need to collect additional rounds for these parameters at these and additional/alternate locations was assessed for the subsequent groundwater sampling events, as results from other analyses (e.g., VOCs, reduced gases, anions) suggested that the microbial community assessment and/or CSIA data were needed at other locations. These additional monitoring locations are presented in Sections 5.6.4.2 and 5.6.4.3.

5.4.2 Flux Measurements using Passive Flux Meters

PFMs were used to determine the change in TCE flux before and after bioaugmentation treatment; comparing data collected upon completion of the first and third groundwater sampling events to PFM data collected prior to implementing bioaugmentation at this site (performed by APTIM in conjunction with SERDP project ER-1613).

The PFM design for organic contaminants is a self-contained permeable activated carbon cartridge that is inserted into a well screen or boring such that groundwater flows horizontally through the cartridge under ambient hydraulic gradients. The PFMs used at this site are constructed in units 1.5 meters (m) long and can be stacked in wells to cover long vertical screen intervals. The activated carbon serves to intercept and retain dissolved hydrophobic organic contaminants present in groundwater flowing through the well screen (Hatfield et al. 2004). The activated carbon is also impregnated with known amounts of soluble ‘resident tracers’, typically alcohols. These tracers are leached from the sorbent at rates proportional to the fluid flux.

After a specified period of exposure to groundwater flow (discussed below), the PFMs were removed from the wells. The sorbent was then carefully extracted to quantify the mass of all organic contaminants intercepted by the PFM and the residual masses of all resident tracers. The contaminant masses were used to calculate time-averaged or cumulative contaminant mass fluxes, while residual resident tracer masses were used to calculate time-averaged or cumulative fluid flux. Results of the PFM testing are discussed in Section 5.7.3. Depth variations of fluxes were measured by vertically segmenting the exposed sorbent at specified depth intervals.

PFMs were installed at select locations following both the first and third groundwater sampling events. The locations for PFM installation included:

- PEW-01 through PEW-04 [immediately downgradient of the treatment and DNAPL source area (see Figure 5.4); and screened across both the low and high permeability zones].
- MWP-1 and MWP-2 [further downgradient of the treatment area (see Figure 5.4); and screened across both the low and high permeability zones].

During each of the two PFM testing events, PFMs remained in the wells for 21 days; from April 28, 2015 to May 19, 2015 for the testing after Groundwater Sampling Event #1; and from August 17, 2016 to September 7, 2016 after Groundwater Sampling Event #3. The PFMs were deployed, retrieved, and sampled by representatives from the University of Florida and APTIM, and the samples were analyzed by the University of Florida. An additional PFM monitoring event was performed by the University of Florida on May 23, 2014, which was prior to initiation of this ESTCP project. Results of these PFM testing results are summarized in Section 5.7.3.

5.4.3 Soil Investigation

One round of soil sampling was performed in the DNAPL source area on April 27 and 28, 2015, following the initial groundwater sampling event to provide an estimate of the DNAPL mass remaining in the source area, and to obtain additional biogeochemical information. Six soil cores were collected (including 1 background core collected upgradient of the demonstration location, and one core collected within the downgradient plume). Woodward Drilling Company (Rio Vista, CA) mobilized a direct push technology drill rig (e.g., Geoprobe) to the site to advance continuous soil core samples, focusing on the target treatment interval (approximately 15 to 25 ft bgs). Soil core locations are shown in Figure 5.4 and include source area locations 4-1DPC-20 through 4-1DPC-23, upgradient location 4-1DPC-19, and plume area location 4-1DPC-24.

Cores collected within the approximate 10-foot treatment interval were visually inspected, photoionization detector (PID) screening was performed along the length of this interval, and up to 13 VOC samples were collected per boring location. Soil VOC samples were collected in methanol-preserved soil jars; this methodology was selected to be consistent with the soil sampling methodology used prior to bioaugmentation.

In addition to the VOC sampling, select soil intervals at each boring location were sampled and analyzed for the following:

- *TOC*. TOC measurements provide insight into potential biomass that is present, potentially serving as an electron donor source as it decays.

- *Microbial Community*. Similar to the analyses described for groundwater, with the focus being on potential shift in community as a function of distance from DNAPL (former or current) sources.

One interval from each of the four source area locations (4-1DPC-20 through 4-1DPC-23) was also sampled for mineralogical speciation. These soil samples were analyzed to assess the extent and type of iron species present, including iron sulfides. These samples were stored anaerobically, as described by Schaefer et al. (2013). Total and ferrous iron were determined using the 1,10-phenanthroline method (Amonette and Templeton, 1998). Mineralogy determination was performed using X-ray diffraction (XRD). XRD was performed to identify the mineralogy of soil cores (including mineral formation induced via the bioremediation) by using a Scintag X1 powder diffractometer system using CuK α radiation with a variable divergent slit and a solid-state detector.

5.4.4 Partitioning Tracer Test

Following completion of groundwater monitoring, soil sampling, and PFM measurement activities, a PTT was to be performed within the treatment area. The PTT (Annable et al., 1998; Hartog et al., 2010) would determine the extent to which DNAPL sources have been removed throughout the site. The testing was to be performed similar to the pre-treatment PTT performed as part of SERDP Project ER-1613 (results shown in Figure 2.6), and as described in Wang et al. (2014). Conservative and partitioning tracers were to be injected as a large slug (approximately 200 gallons) using the 3 injection wells, while groundwater was extracted simultaneously at the 4 extraction wells (see Figure 5.4).

Fabrication and installation of the groundwater recirculation and tracer injection system, as described in Section 5.3.2, commenced in October 2016. Upon initial water testing of the system components, it was discovered that the yield of the injection wells was very low. Drawdown/recharge testing was performed on the three injection well (SIW-01 through SIW-03) on October 28, 2016, and recharge at all three wells was approximately 0.04 gal/min; too low for implementation of the recirculation PTT. Because all the underground and well connection piping (constructed as part of SERDP Project ER-1613) was glued, the costs to excavate, disconnect, and reconstruct this piping to access the wells for rehabilitation were too great and beyond the scope of this current project.

Therefore, upon exploration of options, it was concluded that push-pull tracer tests, similar to those conducted previously at the site as part of SERDP Project ER-1613, would be conducted at two source area monitoring wells, SPW3-1 and SPW4. Similar to the recharge tests performed at the injection wells, recharge testing was performed at SPW3-1 and SPW-4 on November 9 and 10, 2016. Prior to testing, the two wells were developed by surging and pumping, as these wells were easily accessible. Initial recharge rates during the tests from both wells were 0.5-1.5 gallons per minute (gpm), confirming that these wells were suitable for the push-pull tests.

The push-pull testing at SPW3-1 and SPW4 was conducted on December 5 through 8, 2016. Approximately 55 gallons of tracer solution was injected into each of the two wells on December 5, 2016. Each 55-gallon tracer mix included 100 grams of bromide, 250 mL of methanol, 120 mL of n-hexanol, and 35 mL of 2-octanol. The following day, December 6, 2016, water was extracted from each of the two wells at approximately 500 mL/min. Tracer sampling (alcohols and bromide) was conducted hourly for the first 12 hours, followed by sampling every two hours for the next 24 hours, then less frequently for the remainder of the testing.

5.4.5 Demobilization

Demobilization of the on-site equipment constructed for the tracer testing was finalized during the first quarter of 2017. The spent granular activated carbon was sampled on February 15, 2017. The waste characterization sample was delivered to the lab (Curtis and Tompkins, Ltd., Berkeley, CA) and analyzed for Target Compound Leachate Procedure (TCLP) VOCs (EPA 1311/8260) and Title 22 Metals (EPA 6010). A Spent Carbon Profile Form was been generated and submitted to the carbon vendor (Carbon Activated Corp., Compton, CA) for approval. The spent carbon was removed from the site on September 14, 2017.

5.5 DATA ANALYSIS

The data analyses methods employed for this demonstration are provided in this section, and the results of these data analyses are discussed in Section 5.7.

5.5.1 Groundwater

Changes in all relevant parameters since cessation of active bioremediation were considered, with a focus on sulfate and methane levels, dissolved contaminant or ethene levels, carbon isotopic fractionation, abiotic daughter products (e.g., acetylene), and microbial community. Each parameter was evaluated independently. Molar balances coupled with carbon isotopic balance were carefully evaluated to determine the extent to which complete dechlorination continued to occur at the site. These data were ultimately used to determine a first-order dechlorination rate constant.

5.5.2 Soil

The primary purpose of the soil data was to determine if residual DNAPL sources remained. The screening criterion use to determine the presence TCE DNAPL was 100 mg/kg of TCE, which is determined based on TCE mass balance and phase partitioning. Values of TCE soil concentrations collected adjacent to soil cores collected prior to bioaugmentation (which were shown to contain DNAPL) facilitated assessment of DNAPL mass removal.

5.5.3 Partitioning Tracer Test

The method described by Schroth et al. (2000), in which comparison of the mean residence time between partitioning and non-partitioning tracers is used to estimate the DNAPL volume, was not applied because separation between partitioning and nonpartitioning tracers was not sufficiently distinct (shown in Section 5.7.4). An alternative approach described by Wang et al. (2014) was used instead. A summary is provided here.

Push-pull nonpartitioning tracer data and contaminant dissolution data were used to estimate DNAPL mass by being scaled to have relative concentrations (Wang et al., 2014; Jawitz et al., 2005; Schroth et al., 2000):

$$\bar{C}_{np} = 1 - \frac{C_{np}}{C_{o-np}} \quad (1)$$

$$\bar{C} = \frac{C}{C_{peak}} \quad (2)$$

where \bar{C}_{np} is the normalized nonpartitioning tracer concentration, C_{np} is the nonpartitioning tracer concentration during the push-pull tracer test, C_{o-np} is input tracer concentration, and \bar{C} is TCE concentration scaled to the maximum concentration C_{peak} during the push-pull tracer test (Wang et al., 2013). Scaled nonpartitioning tracer data was fit using the Equilibrium Stream Tube (EST) model to determine μ_{lnt} and σ_{lnt} by assuming no DNAPL ($\mu_{lnt} = \mu_{lnt}$, $\sigma_{lnt} = \sigma_{lnt}$) (Wang et al. 2014). The first moment of the t distribution (m_1^t) was calculated as (Wang et al., 2014):

$$m_1^t = e^{\mu_{lnt} + \frac{\sigma_{lnt}^2}{2}} \quad (3)$$

The peak scaled TCE dissolution data was fit using Eq. (1) to determine μ_{lnt} , σ_{lnt} , and f_c and was then used to calculation the first moment of the τ distribution (m_1^τ) (Wang et al., 2014):

$$m_1^\tau = e^{\mu_{lnt} + \frac{\sigma_{lnt}^2}{2}} \quad (4)$$

The first moment of the \hat{S} distribution ($m_1^{\hat{S}}$) is described by (Wang et al., 2014):

$$m_1^{\hat{S}} = K_w m_1^t m_1^\tau \quad (5)$$

where K_w is the NAPL partitioning coefficient. From here, the volume of DNAPL in the source zone (V_N) can be estimated by:

$$V_N = f_c V_{sz} m_1^{\hat{S}} \quad (6)$$

where V_{sz} is the source zone volume.

5.5.4 Overall Assessment – Qualitative and Quantitative Aspects

Data collected and evaluated as part of this project was used to develop an overall conceptual model for the Alameda source area and provide improved insight regarding the long-term effectiveness of bioaugmentation for DNAPL sources. It was expected that this long-term assessment will facilitate improved design, implementation, monitoring, and management of DNAPL-impacted aquifers where bioaugmentation is applied.

The results of this assessment were intended to address the questions posed in Table 2.1. A document was prepared (see Appendix B) to identify fundamental and practical insights that will be applicable to other DoD DNAPL source areas, in alignment with the ultimate goal of facilitating technology transfer and providing guidance when considering bioaugmentation for treatment of DNAPL source areas. Specific items that are addressed in this stand-alone document include the following:

- What tools are most useful for treatment design?
- What monitoring should be performed to ensure treatment effectiveness?
- What are the expected dechlorination and DNAPL dissolution rates?
- What remedial levels are attainable (e.g., MCLs)?
- What are reasonable expectations in terms of reductions in contaminant flux?
- How can treatment scale and timeframe be more effectively designed considering downgradient migration of amendments and/or post-treatment reductive dechlorination due to biomass decay or abiotic processes?
- To what extent is long-term monitoring required in order to understand overall remedial effectiveness?

An important quantitative component of this assessment was to determine DNAPL dechlorination rates that have persisted 3.7 years following active bioremediation using a rapidly consumable electron donor (lactate). This was performed empirically by using a combination of chlorinated ethene and carbon isotopic data, ultimately providing an estimate for an overall dechlorination rate constant.

5.6 SAMPLING METHODS

Groundwater sampling was conducted in order to assess contaminant rebound, quantify the extent of any long term abiotic or biotic dechlorination, and evaluate biogeochemical conditions. Section 5.4.1 describes the groundwater parameters in detail. Groundwater sampling also was used to evaluate tracer migration during the PTT (Section 5.4.4). Similarly, soil sampling was performed to estimate the extent of TCE DNAPL mass remaining, and to further assess biogeochemical conditions.

All activities were conducted in accordance with the site-specific health and safety documents presented in Appendix B of the Demonstration Plan (CBI, 2015), including the Accident Prevention Plan (APP) and the corresponding Site Safety and Health Plan for Alameda Point.

5.6.1 Groundwater Sampling

Groundwater monitoring, extraction, and injection wells were sampled in accordance with the procedures described in this section. The sampling method used was dependent on well construction with standard parameter measurements taken in conventional large diameter monitoring, extraction and injection wells. Modified sampling procedures were applied to MLS and small diameter conventional wells. The wells were purged, by micro-purge technique, prior to sampling using a pump and dedicated tubing.

Groundwater samples were collected from the monitoring wells using a portable bladder or peristaltic pump and low flow techniques. Dedicated polyethylene/Teflon-lined tubing was maintained for each monitoring well. Specific considerations for individual well types are as follows:

- Large Well (2-inch or greater diameter) – Sampling was conducted using a standard 1.5-inch (nominal) diameter down-hole bladder pump. Field chemistry parameters were measured during the purge process and sampling was initiated once parameters stabilized, as discussed below.
- Narrow Diameter Well (less than 2-inch diameter) - Sampling was conducted using a surface based peristaltic pump. Field chemistry parameters were measured during the purge process and sampling was initiated once parameters stabilized, as discussed below.
- Multilevel Wells (SMLS and PMLS Series) Sampling was conducted using a surface based peristaltic pump. Sampling was initiated after purging a minimum of 1 liter of groundwater. No field chemistry parameters were measured during the purge process.

Where purging required the measurement of field parameters, the field sampler monitored purged water for turbidity, pH, temperature, and specific conductivity using a hand-held instrument (YSI 6920) and a flow through cell. After the monitoring wells were purged and the field parameters stabilized, groundwater samples were collected directly from the end of the pump tubing. Dedicated down hole sample tubing was maintained within each well.

5.6.2 Decontamination

The portable bladder pumps were decontaminated before being inserted into each monitoring well in accordance with CB&I SOP EID-FS-014. Sampling and measuring equipment that was reused in multiple wells was decontaminated prior to use. This includes materials potentially exposed to contaminants, such as bladder pumps and water level indicators. Decontamination of sampling and measurement equipment included the following:

- Initial wash using Alconox or other approved detergent;
- Rinse with potable water; and
- Air dry or drying using clean towel.

The use of dedicated down-hole tubing and the replacement of sampling bladders between wells precluded the need to decontaminate all but the reusable metallic components of bladder pumps. Peristaltic pumps using dedicated or disposable tubing required no decontamination.

5.6.3 Analytical and Sample Preservation for Groundwater Samples

The analytical methods and sample preservation used for the analyses that were part of this demonstration are summarized in Table 5.4 below.

Table 5.4 Analytical Methods, Preservation, and Containers (Groundwater)

| Analyte | Method/ Laboratory | Preservative | Bottle |
|--|---|---|--|
| VOCs | EPA 8260 APTIM | 4°C with HCl | 40 mL VOA vial (x2) |
| Anions | EPA 300.0 APTIM | 4°C | 120 mL polyethylene screw-cap (x1) |
| Reduced Gases | EPA 3810 APTIM | 4°C with HCl | 40 mL VOA vial (x2) |
| Dissolved Hydrogen | RSK 175 APTIM | 4°C with HCl | 125 mL glass serum bottle with Teflon-lined cap and crimp seal |
| TOC | EPA 415.1 APTIM | 4°C with H ₃ PO ₃ | 120 mL polyethylene screw-cap (x1) |
| Volatile Fatty Acids | EPA 300m APTIM | 4°C | 40 mL VOA vial (x2) |
| Microbial Community | QuantArray (chlor) Microbial Insights | 4°C | 1 L glass bottle |
| CSIA (carbon) | Chlorinated Carbon Isotopes 13C/12C Pace Analytical | 4°C with HCl | 40 mL VOA vial (x9) |
| Metals - dissolved (Fe, Mn) | EPA 6010 Pace Analytical | 4°C with HNO ₃ | 120 mL polyethylene screw-cap (x2) |
| Dissolved Oxygen pH Turbidity ORP | Field Meter | -- | -- |

5.6.4 Groundwater Sampling Locations and Frequency

As was discussed in Section 5.4.1, a full set of 106 sample intervals were monitored during the first sampling event, with each of the following two sampling events containing fewer monitoring intervals based on the results of the previous events. The following subsections present the monitoring locations for each of the three groundwater sampling events.

5.6.4.1 Groundwater Sampling Event No. 1

The initial groundwater sampling event was conducted in the field from March 9, 2015 through March 26, 2015; and included the sampling of 106 monitoring intervals, as discussed in Section 5.4.1. Table 5.5 summarizes the monitoring locations and analytical suite for Groundwater Sampling Event No. 1.

Table 5.5 Location and Parameter Summary – Groundwater Sampling Event No. 1

| WELL ID | VOCs | Reduced Gases | Anions | Dissolved Metals | VFAs | Dissolved Hydrogen | TOC | Quant Array | CSIA | Field Parameters | | | |
|------------------|------|---------------|--------|------------------|------|--------------------|-----|-------------|------|------------------|----|-----------|-----|
| | | | | | | | | | | DO | pH | Turbidity | ORP |
| MW360-5 | x | x | x | x | x | x | x | x | x | x | x | x | x |
| SIW-01 | x | x | x | x | x | x | x | | | x | x | x | x |
| SIW-02 | x | x | x | x | x | x | x | | | x | x | x | x |
| SIW-03 | x | x | x | x | x | x | x | | | x | x | x | x |
| SMLS1-1 | x | x | x | x | x | x | x | x | x | | | | |
| SMLS1-2 | x | x | x | x | x | x | x | | | | | | |
| SMLS1-3 | x | x | x | x | x | x | x | x | x | | | | |
| SMLS1-4 | x | x | x | x | x | x | x | | | | | | |
| SMLS1-5 | x | x | x | x | x | x | x | | | | | | |
| SMLS1-6 | x | x | x | x | x | x | x | x | x | | | | |
| SMLS1-7 | x | x | x | x | x | x | x | | | | | | |
| SMLS2-1 thru 2-7 | x | x | x | x | x | x | x | | | | | | |
| SMLS3-1 thru 3-7 | x | x | x | x | x | x | x | | | | | | |
| SMLS4-1 thru 4-7 | x | x | x | x | x | x | x | | | | | | |
| SMLS5-1 | x | x | x | x | x | x | x | x | x | | | | |
| SMLS5-2 | x | x | x | x | x | x | x | | | | | | |
| SMLS5-3 | x | x | x | x | x | x | x | x | x | | | | |
| SMLS5-4 | x | x | x | x | x | x | x | | | | | | |
| SMLS5-5 | x | x | x | x | x | x | x | | | | | | |
| SMLS5-6 | x | x | x | x | x | x | x | x | x | | | | |
| SMLS5-7 | x | x | x | x | x | x | x | | | | | | |
| SMLS6-1 thru 6-7 | x | x | x | x | x | x | x | | | | | | |
| SMLS7-1 | x | x | x | x | x | x | x | x | x | | | | |
| SMLS7-2 | x | x | x | x | x | x | x | | | | | | |
| SMLS7-3 | x | x | x | x | x | x | x | x | x | | | | |
| SMLS7-4 | x | x | x | x | x | x | x | | | | | | |
| SMLS7-5 | x | x | x | x | x | x | x | | | | | | |
| SMLS7-6 | x | x | x | x | x | x | x | x | x | | | | |
| SMLS7-7 | x | x | x | x | x | x | x | | | | | | |
| SMLS8-1 thru 8-7 | x | x | x | x | x | x | x | | | | | | |
| PEW1 | x | x | x | x | x | x | x | | | x | x | x | x |
| PEW2 | x | x | x | x | x | x | x | x | x | x | x | x | x |
| PEW3 | x | x | x | x | x | x | x | x | x | x | x | x | x |
| PEW4 | x | x | x | x | x | x | x | | | x | x | x | x |
| PMLS1-1 thru 1-7 | x | x | x | x | x | x | x | | | | | | |
| PMLS2-1 thru 2-7 | x | x | x | x | x | x | x | | | | | | |
| PMLS3-1 thru 3-7 | x | x | x | x | x | x | x | | | | | | |
| PMLS4-1 | x | x | x | x | x | x | x | x | x | | | | |
| PMLS4-2 | x | x | x | x | x | x | x | | | | | | |
| PMLS4-3 | x | x | x | x | x | x | x | | | | | | |
| PMLS4-4 | x | x | x | x | x | x | x | | | | | | |
| PMLS4-5 | x | x | x | x | x | x | x | x | x | | | | |
| PMLS4-6 | x | x | x | x | x | x | x | | | | | | |
| PMLS4-7 | x | x | x | x | x | x | x | | | | | | |
| PMLS5-1 thru 5-7 | x | x | x | x | x | x | x | | | | | | |
| PMLS6-1 thru 6-7 | x | x | x | x | x | x | x | | | | | | |

Notes:
VOCs - volatile organic compounds
VFAs - volatile fatty acids
TOC - total organic carbon
CSIA - compound specific isotope analysis
DO - dissolved oxygen
ORP - oxidation reduction potential

5.6.4.2 Groundwater Sampling Event No. 2

The second groundwater sampling event was conducted in the field from December 1, 2015 through December 15, 2015; and included the sampling of 66 monitoring intervals, based on the results from the first groundwater sampling event. Table 5.6 summarizes the monitoring locations and analytical suite for Groundwater Sampling Event No. 2. It should be noted that volatile fatty acids (VFAs) were not analyzed during the second and third groundwater sampling events.

Table 5.6 Location and Parameter Summary – Groundwater Sampling Event No. 2

| WELL ID | VOCs | Reduced Gases | Anions | Dissolved Metals | Dissolved Hydrogen | TOC | Quant Array | CSIA | Field Parameters | | | |
|------------------|------|---------------|--------|------------------|--------------------|-----|-------------|------|------------------|----|-----------|-----|
| | | | | | | | | | DO | pH | Turbidity | ORP |
| MW360-5 | x | x | x | x | | x | | x | x | x | x | x |
| SIW-01 | x | x | x | x | | x | | | x | x | x | x |
| SIW-02 | x | x | x | x | | x | x | | x | x | x | x |
| SIW-03 | x | x | x | x | | x | | | x | x | x | x |
| SMLS1-1 | x | x | x | x | | x | | x | | | | |
| SMLS1-2 | x | x | x | x | | x | | | | | | |
| SMLS1-3 | x | x | x | x | | x | | x | | | | |
| SMLS1-4 | x | x | x | x | | x | | | | | | |
| SMLS1-5 | x | x | x | x | | x | | | | | | |
| SMLS1-6 | x | x | x | x | | x | | x | | | | |
| SMLS1-7 | x | x | x | x | | x | | | | | | |
| SMLS2-1 | x | x | x | x | | x | x | x | | | | |
| SMLS2-2 | x | x | x | x | | x | | | | | | |
| SMLS2-3 | x | x | x | x | | x | | | | | | |
| SMLS2-4 | x | x | x | x | | x | | | | | | |
| SMLS2-5 | x | x | x | x | | x | x | x | | | | |
| SMLS3-1 | x | x | x | x | | x | | | | | | |
| SMLS3-2 | x | x | x | x | | x | x | x | | | | |
| SMLS3-3 | x | x | x | x | | x | | | | | | |
| SMLS3-4 | x | x | x | x | | x | x | x | | | | |
| SMLS4-1 | x | x | x | x | | x | x | x | | | | |
| SMLS4-2 | x | x | x | x | | x | | | | | | |
| SMLS4-3 | x | x | x | x | | x | | | | | | |
| SMLS4-4 | x | x | x | x | | x | x | x | | | | |
| SMLS4-5 | x | x | x | x | | x | | | | | | |
| SMLS5-1 | | x | x | x | | x | x | | | | | |
| SMLS5-2 thru 5-6 | | x | x | x | | x | | | | | | |
| SMLS7-1 | x | x | x | x | x | x | | x | | | | |
| SMLS7-2 | x | x | x | x | | x | x | x | | | | |
| SMLS7-3 | x | x | x | x | | x | | x | | | | |
| SMLS7-4 | x | x | x | x | | x | x | x | | | | |
| SMLS7-5 | x | x | x | x | | x | | | | | | |
| SMLS8-1 thru 8-4 | x | x | x | x | | x | | | | | | |
| PEW1 | x | x | x | x | | x | | | x | x | x | x |
| PEW2 | x | x | x | x | | x | | x | x | x | x | x |
| PEW3 | x | x | x | x | x | x | | x | x | x | x | x |
| PEW4 | x | x | x | x | | x | | | x | x | x | x |
| PMLS1-1 thru 1-4 | x | x | x | x | | x | | | | | | |
| PMLS2-1 thru 2-4 | x | x | x | x | | x | | | | | | |
| PMLS3-1 | x | x | x | x | | x | x | x | | | | |
| PMLS3-2 | x | x | x | x | | x | | | | | | |
| PMLS3-3 | x | x | x | x | | x | x | x | | | | |
| PMLS3-4 | x | x | x | x | | x | | | | | | |
| PMLS3-5 | x | x | x | x | | x | | | | | | |
| PMLS4-1 | x | x | x | x | | x | x | x | | | | |
| PMLS4-2 thru 4-5 | x | x | x | x | | x | | | | | | |
| PMLS5-1 thru 5-4 | x | x | x | x | | x | | | | | | |

Notes:

VOCs - volatile organic compounds

TOC - total organic carbon

CSIA - compound specific isotope analysis

DO - dissolved oxygen

ORP - oxidation reduction potential

5.6.4.3 Groundwater Sampling Event No. 3

The third groundwater sampling event was conducted in the field from August 1, 2016 through August 11, 2016; and included the sampling of 42 monitoring intervals, primarily based on the results from the first two groundwater sampling events. In addition, samples were collected at select monitoring intervals for a number of analytes under SERDP Project ER-2419. Table 5.7 summarizes the monitoring locations and analytical suite for Groundwater Sampling Event No. 3, including those samples collected and analyzed under SERDP Project ER-2419.

The analytical results from samples collected under SERDP Project ER-2419 are included in the discussion of results in this report (Section 5.7). It should be noted that VFAs, dissolved metals, dissolved hydrogen, and TOC were not analyzed during the third groundwater sampling events. In addition, the QuantArray analysis was replaced by DHC analysis at select locations, as shown in Table 5.7.

Table 5.7 Location and Parameter Summary – Groundwater Sampling Event No. 3

| WELL ID | VOCs | Reduced Gases | Anions | DHC | Quant Array | CSIA | Field Parameters | | | |
|------------------|------|---------------|--------|-----|-------------|------|------------------|----|-----------|-----|
| | | | | | | | DO | pH | Turbidity | ORP |
| MW360-5 | x | x | x | x | | | x | x | x | x |
| SIW-02 | x | x | x | x | | | x | x | x | x |
| SMLS1-1 | x | x | x | | x | x | | | | |
| SMLS1-2 thru 1-6 | x | x | x | | x | x | | | | |
| SMLS1-7 | x | x | x | | x | x | | | | |
| SMLS2-1 thru 2-5 | x | x | x | | | | | | | |
| SMLS4-1 | x | x | x | | x | x | | | | |
| SMLS4-2 | x | x | x | | x | x | | | | |
| SMLS4-3 | x | x | x | | x | x | | | | |
| SMLS4-4 | x | x | x | | x | x | | | | |
| SMLS4-5 | x | x | x | | x | x | | | | |
| SMLS4-6 | x | x | x | | x | x | | | | |
| SMLS4-7 | x | x | x | | x | x | | | | |
| SMLS7-1 | x | x | x | x | | | | | | |
| SMLS7-2 | x | x | x | | | x | | | | |
| SMLS7-3 | x | x | x | x | | x | | | | |
| SMLS7-4 | x | x | x | | | | | | | |
| SMLS7-5 | x | x | x | | | | | | | |
| SPW-1 | x | x | x | | x | x | x | x | x | x |
| SPW3-1 | x | x | x | | x | x | x | x | x | x |
| SPW3-2 | x | x | x | | x | x | x | x | x | x |
| PEW-01 | x | x | x | | | | x | x | x | x |
| PEW-02 | x | x | x | | x | x | x | x | x | x |
| PEW-03 | x | x | x | x | | x | x | x | x | x |
| PEW-04 | x | x | x | | | | x | x | x | x |
| PMLS2-1 | x | x | x | x | | x | | | | |
| PMLS2-2 | x | x | x | x | | x | | | | |
| PMLS2-3 | x | x | x | | | x | | | | |
| PMLS3-1 | x | x | x | x | | x | | | | |
| PMLS3-2 | x | x | x | x | | x | | | | |
| PMLS3-3 | x | x | x | | | x | | | | |
| PMLS4-1 | x | x | x | x | | x | | | | |
| PMLS4-2 | x | x | x | x | | x | | | | |
| PMLS4-3 | x | x | x | | | | | | | |

Notes:

VOCs - volatile organic compounds

DHC - *dehalococcoides* spp. (only)

CSIA - compound specific isotope analysis

DO - dissolved oxygen

ORP - oxidation reduction potential

Sample collection and analysis performed under SERDP Project ER-2419. Analytical results are included in this report.

5.6.5 Analytical and Sample Preservation for Soil Samples

The analytical methods and sample preservation used for the analyses that were part of this demonstration are summarized in Table 5.8 below.

Table 5.8 Analytical Methods, Preservation, and Containers (Soil)

| Analyte | Method/ Laboratory | Preservative | Bottle |
|--------------------------|--|--------------------------------------|----------------------|
| VOCs | EPA 8260 APTIM | 4°C with MeOH | 2 oz. glass jar (x1) |
| TOC | SW-846 9060 APTIM | 4°C | 2 oz. glass jar (x1) |
| Microbial Community | QuantArray (chlor) Microbial Insights | 4°C | 8 oz. poly jar |
| CSIA (carbon) | Chlorinated Carbon Isotopes 13C/12C Pace Analytical | 4°C | 4 oz. glass jar (x1) |
| Mineralogical Speciation | See Section 5.5.3 Univ. Miami-Ohio | 4°C with N ₂ headspace | Soil Bag (x1) |

5.6.6 Soil Sampling Locations and Frequency

As was discussed in Section 5.4.3, soils samples were collected at the six soil boring locations shown on Figure 5.4. The soil sampling event was conducted in the field on April 27 and 28, 2015. Table 5.9 summarizes the soil sampling locations/intervals and analytical suite for the sampling activities.

Table 5.9 Location and Parameter Summary – Soil Sampling Event

| Soil Boring Location ID | Analyte | Number of Samples Analyzed | Sample Depth(s) (ft-bgs) |
|----------------------------|---------------------|-------------------------------|---|
| 4-1DPC-19 | VOCs | 1 | 18 |
| | TOC | 1 | 17.3 |
| | Microbial Community | 1 | 17.8 |
| | CSIA | 1 | 17.6 |
| 4-1DPC-20 | VOCs | 7 | 19, 19.3, 19.6, 20, 20.6, 21, 21.6 |
| | TOC | 2 | 19.4, 20.11 |
| | Microbial Community | 2 | 19.5, 22.2 |
| | CSIA | 1 | 19.7 |
| 4-1DPC-21 | VOCs | 13 | 17, 17.5, 18, 18.3, 18.5, 18.8, 19, 19.3, 19.6, 19.9, 20S, 20D, 22 |
| | TOC | 2 | 17.3, 22.6 |
| | Microbial Community | 2 | 18.3, 22 |
| | CSIA | 1 | 18 |
| 4-1DPC-22 | VOCs | 4 | 17.8, 18.1, 18.9, 21 |
| | TOC | 1 | 17.9 |
| | Microbial Community | 2 | 17.4, 21 |
| | CSIA | 0 | -- |
| 4-1DPC-23 | VOCs | 4 | 18, 19, 19.6, 21 |
| | TOC | 1 | 19.4 |
| | Microbial Community | 2 | 17.5, 21.2 |
| | CSIA | 0 | -- |
| 4-1DPC-24 | VOCs | 2 | 18, 22 |
| | TOC | 2 | 17.3, 21.6 |
| | Microbial Community | 2 | 17.6, 21.3 |
| | CSIA | 2 | 17.6, 21.9 |

5.6.7 Quality Assurance for Groundwater and Soil Sampling and Analysis

5.6.7.1 Calibration Procedures and Frequency

Calibration refers to the checking of physical measurements of both field and laboratory instruments against accepted standards. It also refers to determining the response function for an analytical instrument, which is the measured net signal as a function of the given analyte concentration. These determinations have a significant impact on data quality and are performed regularly. In addition, preventative maintenance is important to the efficient collection of data. For preventative maintenance purposes, critical spare parts were obtained from the instrument manufacturer.

All field and laboratory instruments were calibrated according to manufacturers' specifications. All APTIM laboratory instruments were calibrated in accordance with established Standard Operating Procedures (SOPs). Calibration was performed prior to initial use, during periods of extended use, and after periods of non-use. Certified standards were used for all calibrations and calibration check measurements. A calibration logbook was maintained by APTIM field and laboratory quality assurance (QA) personnel.

5.6.7.2 Quality Control Samples

Internal quality control (QC) data provides information for identifying and defining qualitative and quantitative limitations associated with measurement data. Analysis of trip blanks provided the primary basis for quantitative evaluation of field data quality. Trip blanks are often used to evaluate the presence of contamination from handling errors or cross-contamination during transport, particularly for VOCs. Trip blanks are often not necessary when the contaminants of concern are non-volatile or have low volatility (e.g., anions, alcohols). Trip blanks were analyzed for VOCs.

5.6.7.3 Sample Documentation

APTIM Lawrenceville, NJ project staff coordinated shipment and receipt of sample bottles, coolers, ice packs, chain of custody (COC) forms, and custody seals. Upon completion of sampling, the COC was filled out and returned with the samples to the APTIM, University of Florida, Microbial Insights, Pace Analytical, and University of Miami-Ohio laboratories. An electronic copy of each COC form was placed in the project database. An important consideration for the collection of environmental data is the ability to demonstrate that the analytical samples have been obtained from predetermined locations and that they have reached the laboratory without alteration. Evidence of collection, shipment, laboratory receipt, and laboratory custody until disposal must be documented to accomplish this. Documentation was accomplished through a COC Record that recorded each sample and the names of the individuals responsible for sample collection, transport, and receipt. A sample is considered in custody if it is:

- In a person's actual possession;
- In view after being in physical possession;
- Sealed so that no one can tamper with it after having been in physical custody; or
- In a secured area, restricted to authorized personnel.

Sample custody was initiated by field personnel upon collection of samples. Samples were packaged appropriately to prevent breakage or leakage during transport and shipped to the laboratory via either hand delivery or commercial carrier.

5.6.7.4 Sample Identification

A discrete well number was assigned to each sample. This discrete identifier was placed on each bottle and was recorded, along with other pertinent data in a field notebook dedicated to the project. The sample identification number designated the sample location (e.g., “SMLS1-1” for this specific monitoring well). The bottle label also contained the site name, the sampling date and time, any preservatives added to the bottle, and the initials of the sampler.

5.6.7.5 Chain-of Custody Forms

The COC Record used by APTIM’s laboratory is shown in Figure 5.5. All samples collected for off-site analysis were physically inspected by the Field Engineer prior to shipment.

Each individual who had sample in their possession signed the COC Record. Preparation of the COC Record was as follows:

- The COC Record was initiated in the field by the person collecting the sample, for every sample. Every sample was assigned a unique identification number entered on the COC Record.
- The record was completed in the field to indicate project, sampling person, etc.
- If the person collecting the samples did transport the samples to the laboratory or ship the samples directly, the first block for “Relinquished By _____, Received By _____” was completed in the field.
- The person transporting the samples to the laboratory or delivering them for shipment signed the record for as “Relinquished By _____”.
- The original COC Record was sealed in a watertight container, taped to the top (inside) of the shipping container, and the shipping container sealed prior to being given to the commercial carrier.

The commercial waybill served as an extension of the COC Record between the final field custodian and receipt by the off-site laboratory.

- Upon receipt by the off-site laboratory, the laboratory QC Coordinator, or designated representative, opened the shipping container(s), compared the contents with the COC Record, and signed and dated the record. Any discrepancies were noted on the COC Record.
- COC Records were maintained with the records for the project and became part of the data package.

- Date and time received.

The COC Record was placed in the project file.

5.6.7.7 Other Documentation

Following sample receipt at the laboratory, the Laboratory Manager or sample custodian clearly documented the processing steps applied to the sample. The analytical data from laboratory QC samples were identified with each batch of related samples. The laboratory log book includes the time, date, and name of the person who logged each sample into the laboratory system. This documentation is thorough enough to allow tracking of the sample analytical history without aid from the analyst. At a minimum, laboratory documentation procedures provide the following:

- Recording in a clear, comprehensive manner using indelible ink.
- Corrections to data and logbooks made by drawing a single line through the error and initialing and dating the correction.
- Consistency before release of analytical results by assembling and cross-checking the information on the sample tags, custody records, bench sheets, personal and instrument logs, and other relevant data to verify that data pertaining to each sample are consistent throughout the record.
- Observations and results identified with the project number, date, and analyst and reviewer signatures on each line, page, or book as appropriate.
- Data recorded in bound books or sheaf of numbered pages, instrument tracings or hard copy, or computer hard copy.
- Data tracking through document consolidation and project inventory of accountable documents: sample logbook, analysis data book, daily journal, instrument logbook, narrative and numerical final reports, etc.

5.7 RESULTS

5.7.1 Soil Core Results

Soil core results at each of the four source area locations (4-1 DPC-20 through 4-1 DPC-23, locations shown in Figure 5.4) are presented in Figure 5.6. Maximum TCE and DCE concentrations were less than 10 mg/kg at the upgradient and downgradient soil boring locations. While both TCE and DCE were observed at each location, only at location 4-1 DPC-20 were concentrations clearly indicative of residual TCE DNAPL, indicating that TCE source remains in this portion of the source area. The depth interval of the elevated TCE source in Figure 5.6 corresponds to the lower permeability material (Figure 2.7). The TCE concentrations and depths present in 4-1 DPC-20 are similar (within 20%) to those measured in an adjacent soil boring collected at SPW-3-2 (Figure 5.4), which was collected several months prior to the previously performed dissolution testing and bioaugmentation (Wang et al., 2014). These data suggest that only a small fraction of the DNAPL mass likely was removed in this portion of the source area, although estimating fractional DNAPL mass removal via soil cores is difficult due to the heterogeneous distribution of DNAPL. The tables presented in Appendix C contain all soil analytical results for the sampling event performed in April 2015.

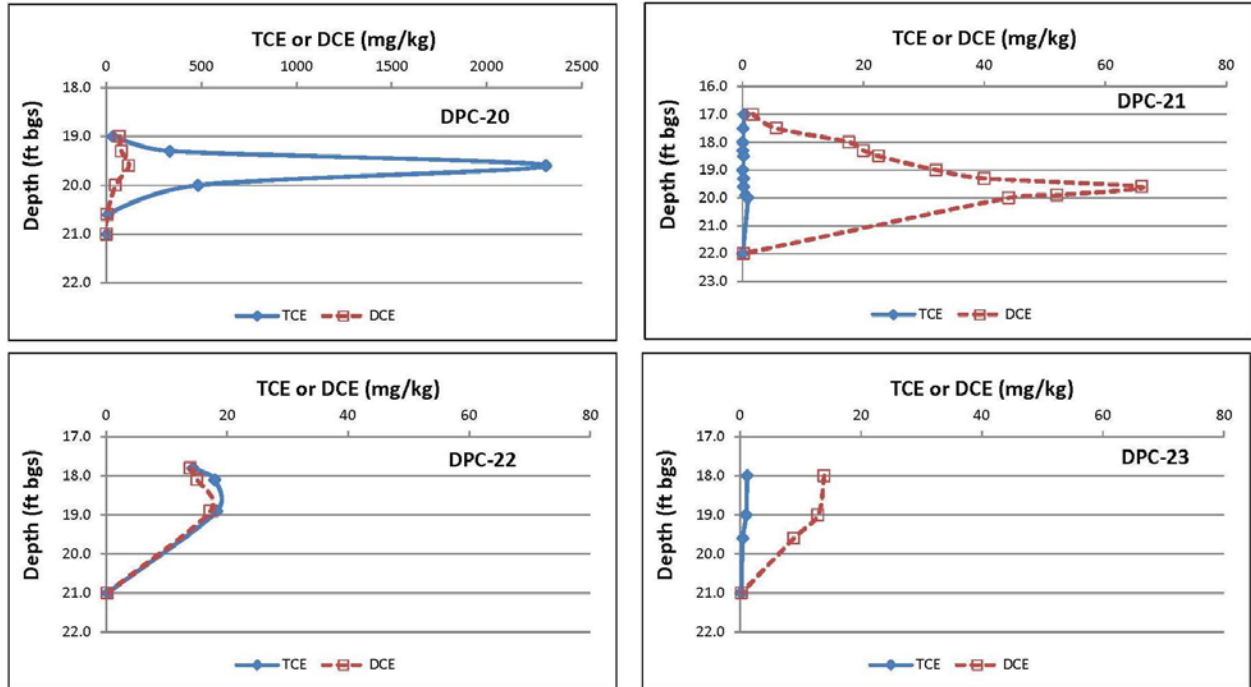

Figure 5.6 TCE and DCE Soil Concentrations in Soil Cores

The x-axis scale for location DPC-20 has been increased due to the relative large TCE concentrations at this location, which are indicative of DNAPL.

In contrast, TCE and DCE concentrations at 4-1 DPC-21 through 4-1 DPC-23 suggest that DNAPL likely is not present (or, present at extremely trace levels) at these locations. Historical soil data collected at DPC-17 (located directly adjacent to 4-1 DPC-23, as shown in Figure 5.4), collected several months prior to the previously performed dissolution testing (Wang et al., 2104) and bioaugmentation, showed TCE concentrations up to 590 mg/kg at a depth of 10.5 ft-bgs. This historical elevated TCE soil concentration, located within the lower permeability material, is indicative of residual TCE DNAPL. Thus, in the vicinity of 4-1 DPC-23, substantial removal of DNAPL sources appears to have occurred following the dissolution and bioaugmentation testing. Assessment of groundwater data in the following sections is used to further evaluate the potential presence of remaining DNAPL sources.

XRD analysis of 18 soil samples collected within the source area did not show any detectable levels of iron sulfide minerals. Thus, despite the iron reducing conditions and dissolved iron that persisted with the source area, the formation and persistence of iron sulfide minerals was not observed.

5.7.2 Groundwater Monitoring Results

The tables presented in Appendix D contain all groundwater analytical results for the three sampling events performed during the demonstration.

5.7.2.1 Groundwater Biogeochemical Conditions

Groundwater monitoring results showed that VFAs were below the analytical detection limit of 1 mg/L at all locations, indicating that (as expected) the lactate and subsequent fermentation products present during active treatment were no longer present in the source area. Dissolved hydrogen levels also were below the analytical detection limit of 0.0084 µg/L.

Despite the absence of any measureable VFAs or dissolved hydrogen in the source area, other biogeochemical indicators suggest that conditions favorable to the biological reductive dechlorination of chlorinated ethenes persisted within the source area up to 3.7 years following active treatment. Naturally-occurring TOC levels in the source area generally ranged from 10 to 30 mg/L, which were consistent with levels measured upgradient and downgradient of the treatment area. More convincingly, comparison of methane, sulfate, and DHC levels measured 3.7 years after active treatment to those measured just prior to bioaugmentation (Table 5.10) suggest that biogeochemical impacts persist in the source area. Dissolved methane levels in the lower permeability materials remained approximately 1 to 2 orders of magnitude greater than pre-bioaugmentation levels; in the higher permeability zone, methane levels ranged from 4- to 22-times greater than pre-bioaugmentation levels. Furthermore, methane levels have shown little dissipation (less than a factor of 2) since immediately after active treatment, even in the higher permeability materials where approximately 3 pore volumes of groundwater have passed through since the end of active treatment. These methane results suggest that methanogenic activity, especially in the low permeability materials, has been sustained 3.7 years following treatment using lactate as the electron donor. Previous studies (Sleep et al., 2005; Adamson and Newell, 2009) suggest that such persistence of reducing conditions in absence of amended electron donor is due to decay of endogenous bacteria that amassed during active treatment.

Table 5.10 Ratios of the Final (Post-Bioremediation) Measured Groundwater Concentrations to those Measured Prior to Bioremediation

| Well Identification | Methane Ratio | Sulfate Ratio | DHC Ratio |
|----------------------------|----------------------|----------------------|------------------|
| <i>Low Permeability</i> | | | |
| SMLS 1-1 | 46 | 0.48 | NA |
| SMLS 1-2 | 40 | 0.50 | 4,700 |
| SMLS 1-3 | 48 | 0.46 | 1,100 |
| SMLS 4-2 | 23 | 0.68 | 1,700 |
| SMLS 4-3 | 124 | 0.48 | 2,000 |
| SMLS 7-1 | 15 | 0.34 | 73,000 |
| SMLS 7-2 | 48 | 0.23 | 830 |
| SMLS 7-3 | 19 | 0.23 | 140 |
| <i>High Permeability</i> | | | |
| SMLS 1-4 | 22 | 0.56 | 438 |
| PEW-02 | 4.4 | 0.64 | NA |
| PEW-03 | 8.6 | 0.80 | NA |

NA = data not available

Consistent with the methane data, Table 5.10 also shows that sulfate reducing conditions persisted in the source area, although measurable sulfate (43 to 208 mg/L) was present at all monitoring locations shown in Table 5.10. Finally, aqueous DHC levels in the lower permeability materials remained several orders of magnitude greater than those observed immediately prior to bioaugmentation; only one monitoring location was monitored for DHC levels in the higher permeability materials prior to bioaugmentation, so while over a 400-fold increase was observed, the limited comparison precludes a definitive assessment for the high flow zone. The persistence of the elevated DHC levels suggests the potential for enhanced dechlorination, but the dechlorinating activity of the DHC and contributions from other dechlorinators cannot be readily attained from this comparison. However, when the methane, sulfate, and DHC data are collectively assessed, the data suggest that conditions conducive to the continued dechlorination of TCE sources persisted, especially in the lower permeability zones.

Assessment of microbial community showed the presence of a wide range of microbial species. Sulfate reducers and eubacteria were approximately 10-times greater in the source area than in the upgradient control well (MW360-5). Also, as expected, DHC levels were typically several orders of magnitude greater in the source area than in the upgradient control well.

5.7.2.2 Groundwater Chlorinated Ethene and Ethene Concentrations

Results in this section focus on source area monitoring locations that were appreciably impacted with chlorinated solvents prior to bioaugmentation, and only the PMLS wells that were in the core of the downgradient plume (the shallowest two intervals of PMLS 3 and 4). Groundwater chlorinated ethene and ethene results for SMLS locations screened within the lower permeability materials are shown in Figure 5.7. Consistent with the soil results (Figure 5.6), chlorinated ethene concentrations at SMLS 1-3 were elevated and consistent with the presence of nearby DNAPL sources. SMLS locations in the adjacent intervals above, and approximately downgradient (SMLS 4 intervals) also show substantial rebound following bioaugmentation treatment; such rebound is not unexpected considering that nearby DNAPL sources persisted. In contrast, monitoring intervals at SMLS 7 showed an absence of contaminant rebound and/or continued decreases in VOC levels following bioaugmentation. This result also is consistent with the soil data which show an absence of DNAPL sources in the vicinity and upgradient of SMLS 7, thus the observed rebound appears to be related to the persistence of DNAPL sources.

The discrete interval sampling results collected at the final sampling event during active remediation (day 61) and from the early post-treatment rebound time (day 110) are consistent with the long term groundwater monitoring and soil sampling performed as part of this study. Total molar chlorinated ethene + ethene concentrations increased at SMLS 1-3 by approximately a factor of 2.5 between the end of active remediation and 49 days after active remediation (day 110), indicating that source DNAPL mass likely is still present. In contrast, total molar chlorinated ethene + ethene concentrations decrease by approximately a factor of two at SMLS 7-3 between the end of active remediation and 49 days after active remediation, suggesting that appreciable removal of DNAPL source has likely occurred. These results highlight the usefulness of discrete interval monitoring locations placed within suspected lower permeability DNAPL source areas for performance monitoring during (and soon after) active bioremediation.

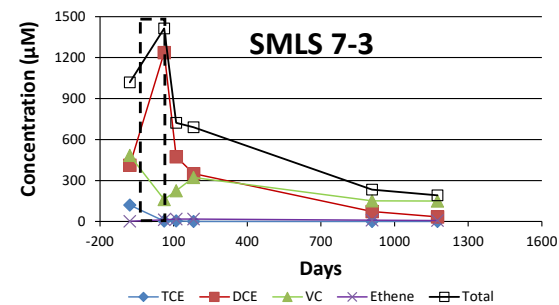
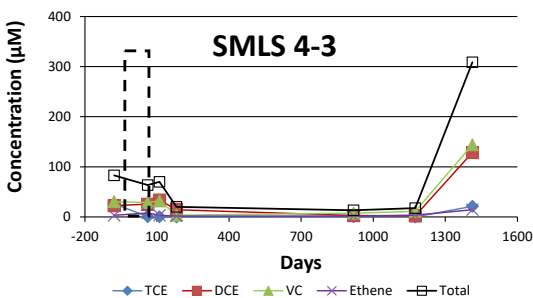
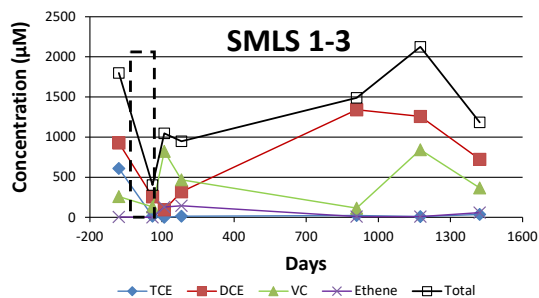
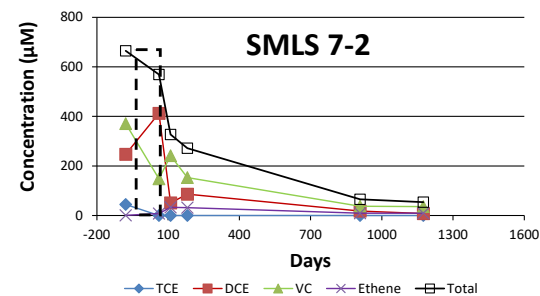
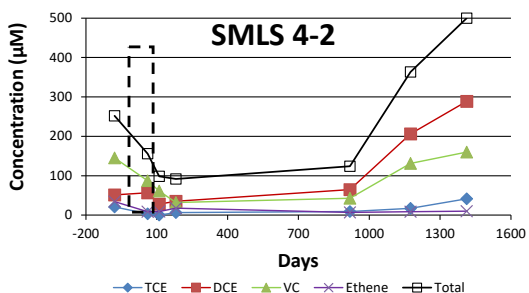
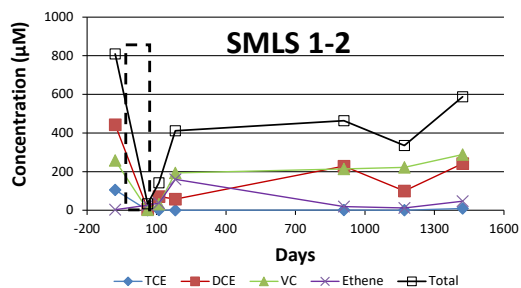
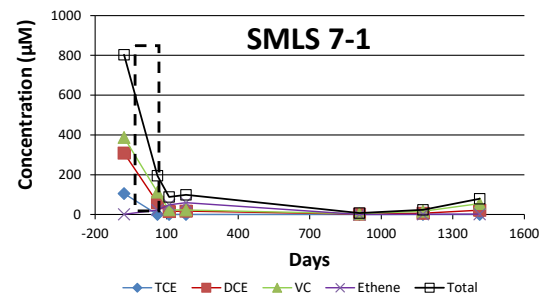
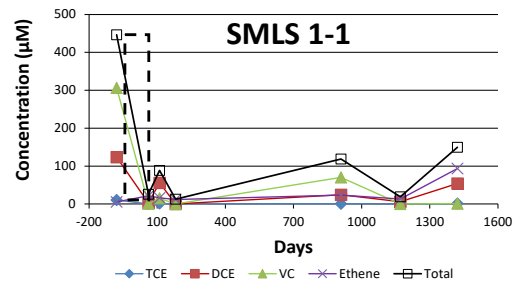

Figure 5.7 Groundwater Chlorinated Ethene and Ethene Results for SMLS Locations Screened within the Lower Permeability Materials

The dashed boxes represent the time intervals where active bioremediation occurred; the high density of data collected during active treatment was omitted for clarity.

Groundwater chlorinated ethene and ethene results for SMLS and extraction well locations screened within the higher permeability materials are shown in Figure 5.8. With respect to contaminant rebound, the trends for monitoring locations screened in the higher permeability materials are similar to those observed for those screened in the lower permeability materials, with locations near and downgradient of SMLS 1 showing rebound and/or contaminant concentrations similar to those observed prior to bioaugmentation. Monitoring locations not adjacent to or downgradient of SMLS 1 (SMLS 4 and PEW03) do not exhibit any measureable rebound and concentrations remain substantially lower than prior to bioaugmentation. The greatly elevated vinyl chloride concentration in PEW03 at 1176 days is considered anomalous.

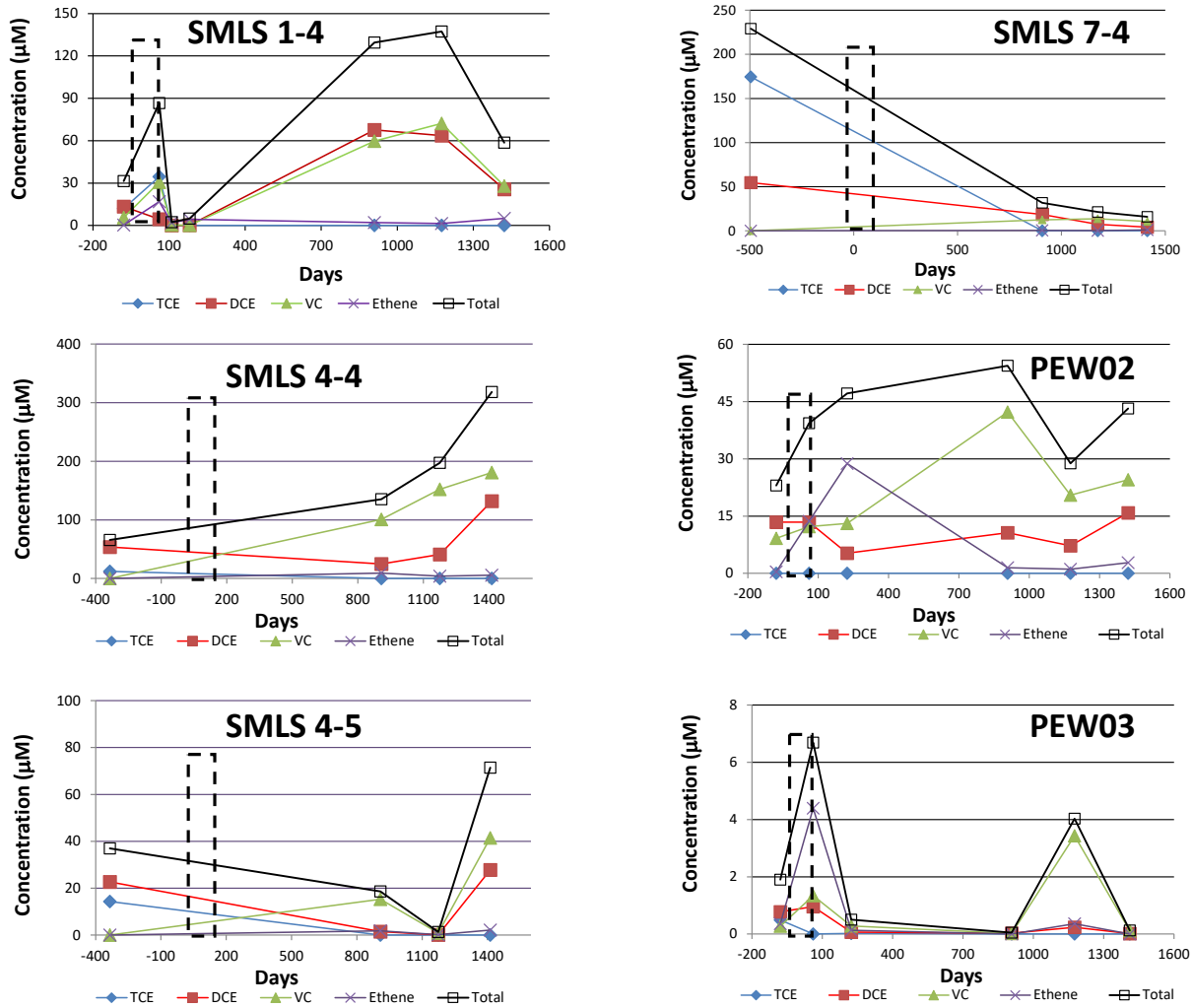

Figure 5.8 Groundwater Chlorinated Ethene and Ethene Results for SMLS and Extraction Well Locations Screened within the Higher Permeability Materials

The dashed boxes represent the time intervals where active bioremediation occurred; the high density of data collected during active treatment was omitted for clarity.

SMLS locations 4-2 through 4-4 show an increasing trend in total chlorinated ethene molar concentrations during the last three monitoring events performed in this study. The reason for this increasing trend is unclear, as increasing trends were not observed in upgradient monitoring locations.

While the molar fraction of ethene compared to the other chlorinated ethenes present was small, both during and after bioaugmentation (Table 5.11), the molar fraction of ethene remained 1 to 2 orders of magnitude greater than baseline (prior to bioaugmentation) at most monitoring locations. Thus, the complete reductive dechlorination of the chlorinated ethenes continued for 3.7 years following active treatment, although the typical molar fraction of ethene suggested that only 2 to 30% of the chlorinated ethene mass was being fully dechlorinated within the source area by the end of the rebound monitoring period. To verify that these ethene levels were due to ongoing generation, rather than slow release from the source area due to generation during active treatment only, groundwater in the three injection wells (Figure 5.4) was monitored. The injection wells were screened similarly to the extraction wells but located immediately upgradient of the source area. The injection wells showed a substantial (>75%) loss of permeability presumably due to biofouling, as noted during the final stage of active treatment and during draw-down testing performed during this current study. While chlorinated ethene levels in the injection wells were all less than 1 µg/L in the 2 to 3.7 years following active treatment, strongly reducing conditions (as evidenced by sulfate reduction and elevated methane levels) persisted. However, ethene was below the analytical detection limit of 5 µg/L in all 3 injection wells, which was substantially less than the ~250 µg/L observed at the end of the active remediation phase. Thus, in the absence of chlorinated ethene sources and limited groundwater flow, ethene did not persist in the source area, thereby confirming that the ethene observed in the source area monitoring locations (Figure 5.4) likely was due to ongoing reductive dechlorination.

Table 5.11 Molar Fraction of Ethene to Chlorinated Ethenes Measured Prior to Bioaugmentation, and at the Last Measured Rebound Event

| Well Identification | Prior to Bioaugmentation | Final Rebound Sampling |
|----------------------------|---------------------------------|-------------------------------|
| <i>Low Permeability</i> | | |
| SMLS 1-1 | 0.013 | 1.7 |
| SMLS 1-2 | 0.0035 | 0.088 |
| SMLS 1-3 | 0.0026 | 0.052 |
| SMLS 4-2 | 0.16 | 0.021 |
| SMLS 4-3 | 0.042 | 0.28* |
| SMLS 7-1 | 0.0020 | 0.031 |
| SMLS 7-2 | 0.0018 | 0.22 |
| SMLS 7-3 | 0.0024 | 0.038 |
| <i>High Permeability</i> | | |
| SMLS 1-4 | 0.0099 | 0.093 |
| PEW-02 | 0.017 | 0.069 |
| PEW-03 | 0.23 | 0.097 |

* the last rebound event appeared anomalously high, so the second to last rebound event was used.

Monitoring locations PMLS 3-2 and 4-2, which are approximately downgradient from PEW-03 and screened in the higher permeability material, show that total chlorinated ethene + ethene concentrations continued to decrease in the downgradient plume (Figure 5.9) following active treatment. These results are consistent with the trends observed in the SMLS 7 intervals (Figures 5.7 and 5.8). Based on the calculated groundwater velocity in the shallow lower permeability zone, water treated during active bioremediation was expected to migrate to PMLS 3-1 and 4-1 by approximately 900 days (assuming no retardation), which provides a possible explanation for the decreasing trend in chlorinated ethenes observed over the last three monitoring events, as treated water may be just beginning to arrive at these locations. Despite the observed impacts of source area treatment on the downgradient PMLS wells, there is no measureable increase in ethene concentrations from the SMLS 7 intervals to the PMLS 3 and 4 intervals (data not shown). This result suggests that continued complete dechlorination did not occur downgradient of the source area, that dilution/dispersion of any ethene generated between the source area and PMLS wells masked the ethene generation, and/or that the ethene was subsequently transformed and not accumulated as a final dechlorination product. This issue is further discussed in the following section.

Potential abiotic dechlorination products acetylene and propane (He et al., 2015; Schaefer et al., 2015) were not detected in any of the groundwater samples. These results suggest that abiotic dechlorination likely was not playing a dominant role at this site, although biotic transformation of any acetylene or propane that was formed may have masked their generation.

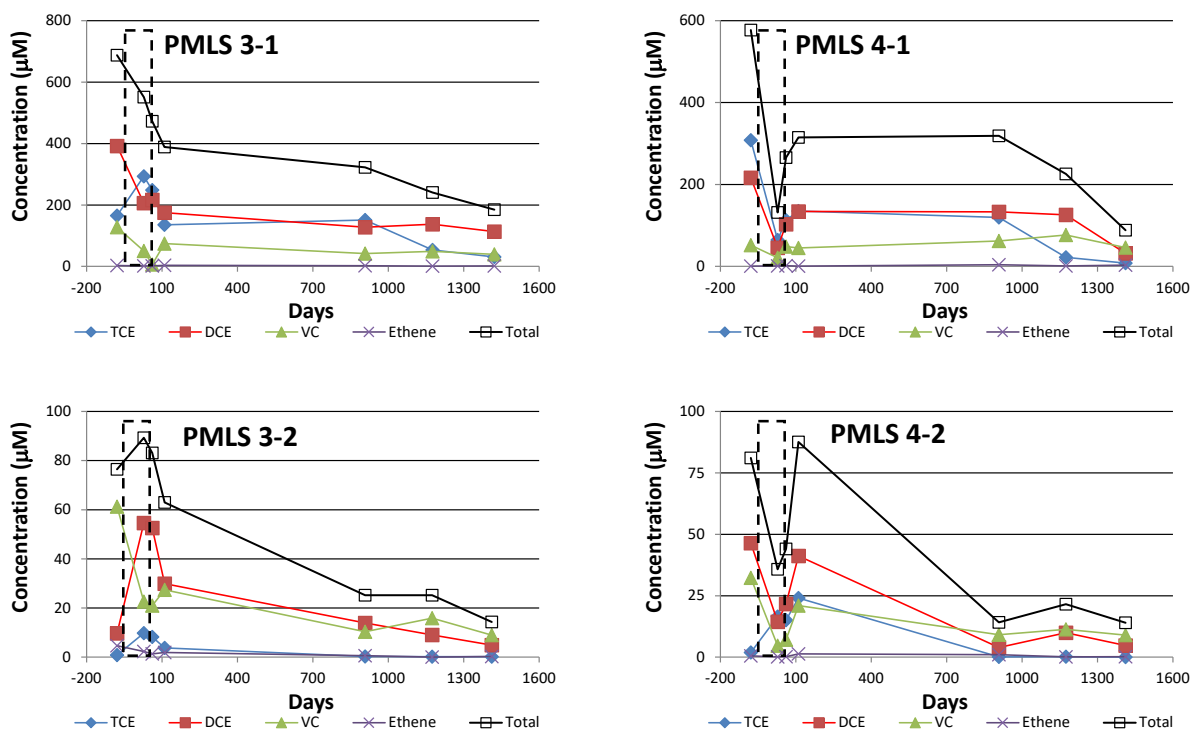

Figure 5.9 Groundwater Chlorinated Ethene and Ethene Results for PMLS Well Locations Screened within the Higher Permeability Materials

The dashed boxes represent the time intervals where active bioremediation occurred.

5.7.2.3 CSIA Assessment

To assess the extent to which complete dechlorination of TCE is occurring at the site, the net carbon isotopic enrichment for TCE, DCE, and VC is calculated as follows:

$$\delta^{13}\text{C} = (x_{\text{TCE}} \delta^{13}\text{C}_{\text{TCE}} + x_{\text{DCE}} \delta^{13}\text{C}_{\text{DCE}} + x_{\text{VC}} \delta^{13}\text{C}_{\text{VC}}) \quad (7)$$

where $\delta^{13}\text{C}$ is the molar weighted isotopic carbon enrichment, x_i is the mole fraction of compound i , and $\delta^{13}\text{C}$ is the ^{13}C isotopic level in either the TCE, DCE, or VC (‰). Figure 5.10(A) shows $\delta^{13}\text{C}$ as a function of total chlorinated ethene molar concentration emanating from the DNAPL sources in the lower permeability materials; Figure 5.10(B) shows the corresponding values for the underlying higher permeability material. In the higher permeability materials, chlorinated ethene enrichment and attenuation are clearly observed. The enrichment factor of -1.87 observed in the higher permeability materials is less than enrichment factors observed for reductive chlorinated ethene biodegradation (Bloom et al., 2000). The relative absence of enrichment and attenuation observed in the lower permeability materials likely is due to the fact that treated water has not yet fully migrated through the downgradient (PMLS) monitoring locations, consistent with the data in Figure 5.9, so isotopic levels do not yet reflect changes due to bioremediation.

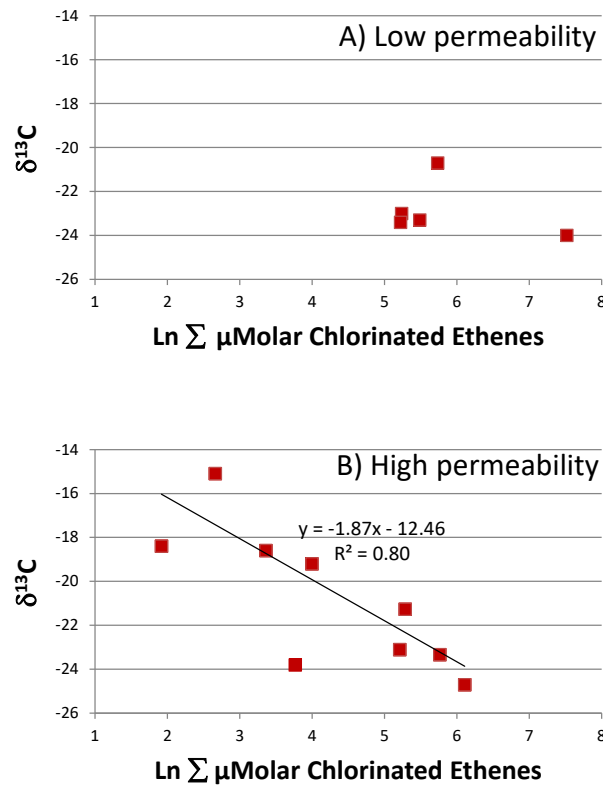

Figure 5.10 Carbon Isotopic Enrichment Measured as a Function of the Total Chlorinated Ethene Concentration in both the Low (top) and High (bottom) Permeability Materials Emanating from the Existing DNAPL Sources through the PMLS Wells

The visibly outlying data point in the bottom figure (3.8 on the x-axis) was not used in the linear regression.

The isotopic and concentration data in Figure 5.10(B) suggest that substantial complete dechlorination of TCE, DCE, and VC occurred, which is in apparent contradiction to the ethene data presented in Table 5.11 that showed ethene (the presumed complete dechlorination transformation product) represented only a small fraction of the molar chlorinated ethenes + ethene. Furthermore, the data in Figure 5.10(B) suggest that the complete dechlorination of chlorinated ethenes continued between the source area and the PMLS wells, despite the absence of any measurable ethene accumulation in this flow interval. While CSIA analysis was not performed on ethene, the low levels of ethene present likely would not have resolved the isotopic balance, as the ethene $\delta^{13}\text{C}$ required to complete the isotopic mass balance would be (based on inclusion of ethene in Eq. 7) approximately -400‰, which is not plausible. This apparent discrepancy suggests that ethene was further transformed, and/or that vinyl chloride transformation proceeded without formation of ethene. Only trace (approximately 10-times less than ethene) ethane was generated, so continued reduction of ethene to ethane cannot explain this discrepancy.

Previous studies have shown that trace levels of oxygen can result in the aerobic transformation of vinyl chloride and ethene (Abe et al., 2009; Gossett, 2010), with enrichment factors that are more in-line with (but still greater than) those observed in Figure 5.10(B). Others have shown that anaerobic oxidation of ethene can occur via sulfate as an electron acceptor (Fullerton et al., 2013). Either, or both, of these oxidative processes readily explains the observed chlorinated ethene fractionation in absence of appreciable stoichiometric quantities of ethene or ethane.

The CSIA data can be used to estimate a first-order complete dechlorination rate constant (k), based on the overall dechlorination of the chlorinated ethenes, using the following expression (ITRC, 2013):

$$k = \frac{v(\delta_0^{13}\text{C} - \delta^{13}\text{C})}{\epsilon d} \quad (8)$$

where $\delta^{13}\text{C}_0$ refers to the initial (upgradient DNAPL source) isotopic enrichment (Eq. 7), v is the ambient superficial velocity through the higher permeability material (0.013 m/day), ϵ is the enrichment factor (slope is Figure 5.10(B)) and d is the distance (17.7 ft from the DNAPL source to the PMLS wells). For evaluation over this distance (shown in Figure 5.4), Eq. 8 yields a first order overall dechlorination rate constant of 0.01 day⁻¹. Assuming that this rate constant has been maintained since the end of active treatment, and assuming a constant chlorinated ethene concentration (maintained by the presence of DNAPL) near SMLS 1-3 of 1,600 μM , chlorinated ethene soil concentrations near SMLS 1-3 would have decreased by approximately 500 mg/kg since the end of active bioremediation. This decrease represents approximately 25% of the DNAPL levels currently near SMLS 1-3 and soil boring location DPC-20 and suggests that biotic dechlorination remains a significant attenuation mechanism 3.7 years after active bioremediation.

5.7.3 Passive Flux Meters

Darcy flow was obtained through PFM testing at the four extraction wells (PEW01 through PEW04) shown in Figure 5.4. Results show that the groundwater flow varied over the duration of monitoring (from prior to bioaugmentation, to nearly four years following active bioremediation). This variability likely was due to precipitation and/or tidal influences.

Results showing total chlorinated ethene and ethene flux measured at the extraction wells (sum of PEW01 through PEW04) are shown in Figure 5.11. These data provide a reasonable estimate of the dissolved contaminant flux emanating from the source area. While the 9/7/2016 data shown in Figure 5.12 suggest that the contaminant molar flux was much lower than the pre-bioaugmentation (12/7/2011) data; the reason for this decreased flux on 9/7/2016 is the reduced Darcy velocity, rather than a decrease in contaminant concentrations in the groundwater. The Darcy velocity on 9/7/2016 is approximately 3-times less than on the other dates shown. Thus, with the exception of the 5/23/2014 data, the PFM results indicate that dissolved contaminant concentrations emanating from the source area have not been substantially reduced. These results are consistent with the groundwater data presented in Section 5.7.2.2. It is important to note that the molar flux at PEW02 is much greater than at the other three extraction wells, so the data shown in Figure 5.12 primarily reflects results at PEW02, which is downgradient of persistent DNAPL sources.

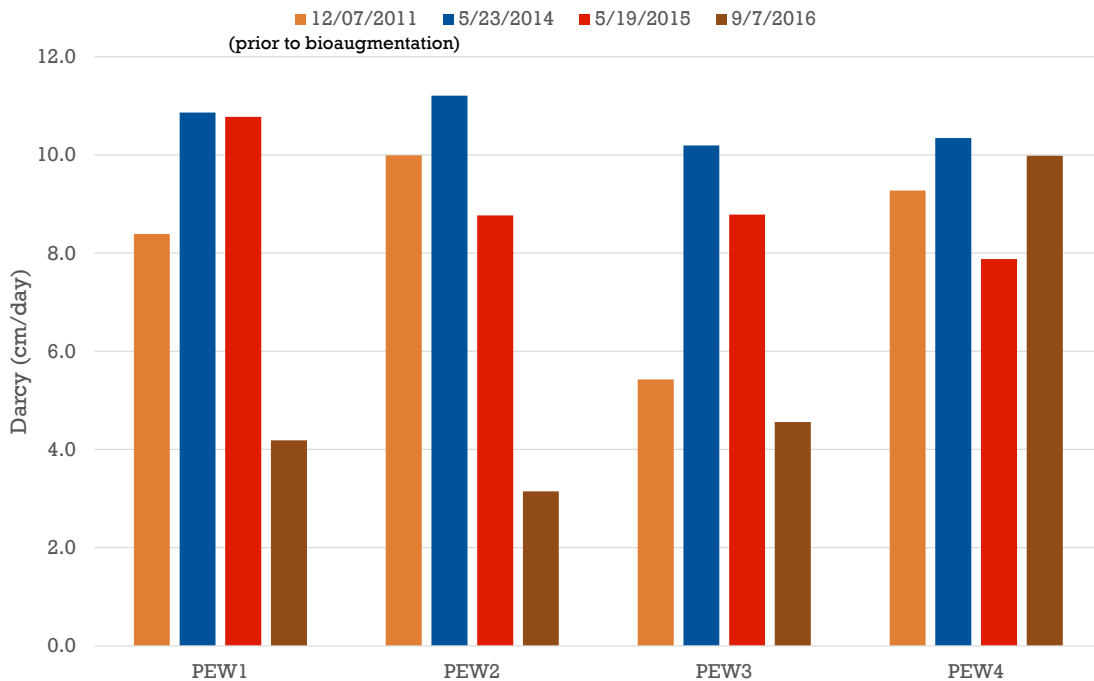

Figure 5.11 Darcy Velocity Measured over the Course of the Study Using PFMs.

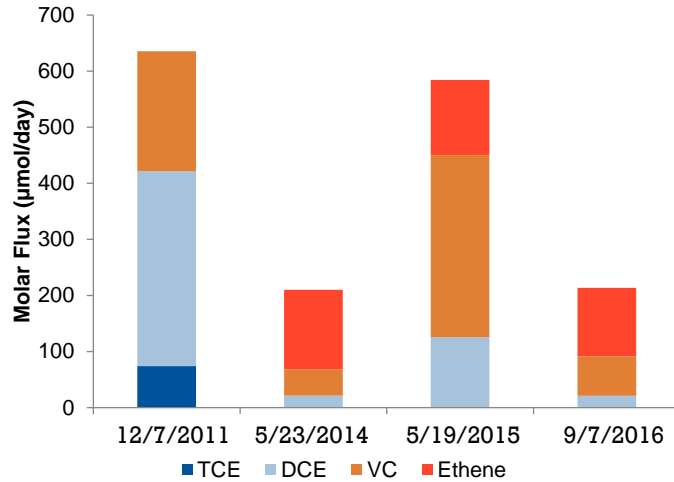

Figure 5.12 Summation of Chlorinated Ethene and Ethene Molar Flux

As summed over the four extraction wells (PEW01 through PEW04). The 12/7/2011 data was collected prior to bioaugmentation, while the remaining three events were performed after bioaugmentation.

5.7.4 Push-Pull Partitioning Tracer Tests

Tracer (bromide and alcohol) results for the push-pull test performed at SPW-4 are shown in Figure 5.13. SPW-4 is located in a region where, based on the soil and groundwater data, DNAPL sources are not expected. Consistent with this, the partitioning alcohol and conservative bromide tracers co-elute, suggesting no DNAPL mass is present. However, the short residence time of the tracers in the aquifer may prevent detection of low levels of residual DNAPL. To further assess the presence of DNAPL, the EST model (described in Section 5.5.3) was used to determine if DNAPL sources were present by comparing the recovery of TCE/DCE (after injecting VOC-free water) to that of bromide (Figure 5.14). The slow increase of DCE relative to the bromide suggests DNAPL sources in the immediate vicinity of SPW-4 are not present. The DNAPL volume in the tested volume surrounding SPW-4 estimated by the EST model was < 0.001 L, indicating that no significant levels of DNAPL were present at this location.

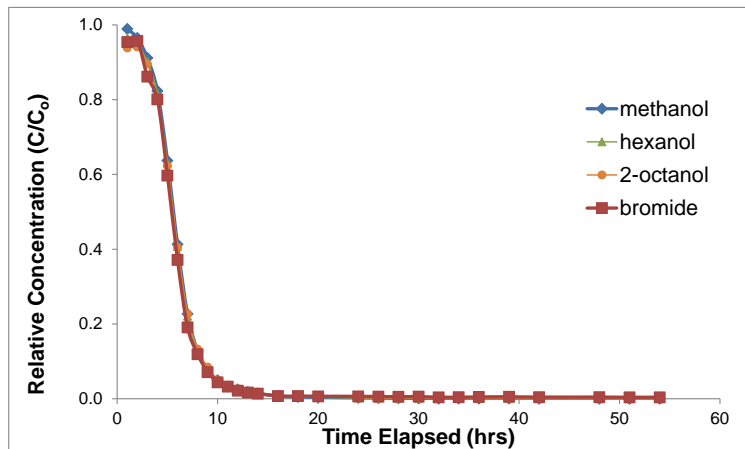

Figure 5.13 Results of the Push-Pull Partitioning Tracer Test at SPW-4

All tracers co-eluted, suggesting residual DNAPL sources were not present.

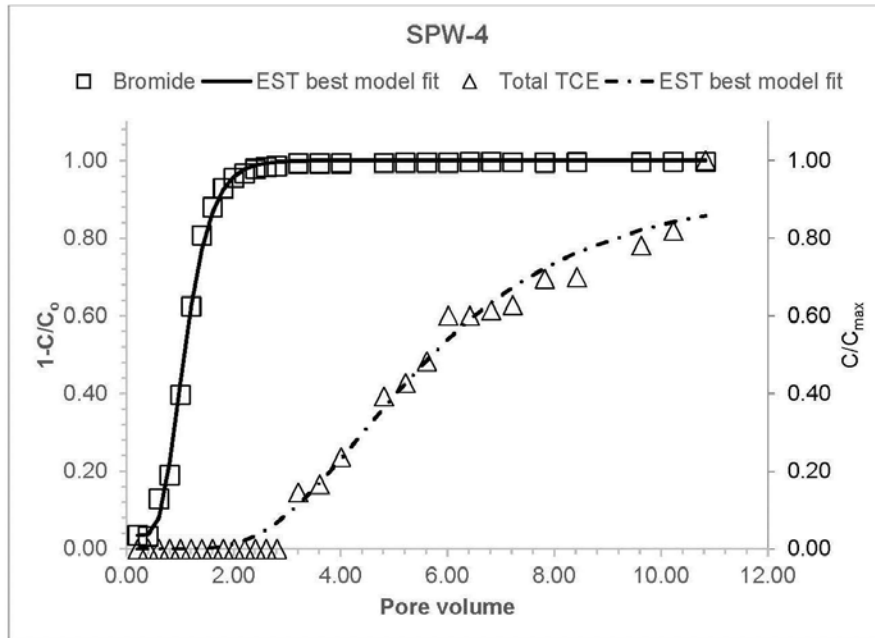

Figure 5.14 EST Model Regressed to Both Bromide and DCE Data during the Push-Pull Test at SPW-4

Tracer (bromide and alcohol) results for the push-pull test performed at SPW3-1 are shown in Figure 5.15. SPW-3-1 is located in a region where, based on the soil and groundwater data, DNAPL sources are likely present. However, the bromide and partitioning tracer data shown in Figure 5.15 do not indicate that DNAPL sources are present, suggesting that the DNAPL mass (or, pore saturation) are too low and tracer residence time is too short to be detected using this method. Again, applying the EST model for the bromide and TCE/DCE recovery, Figure 5.16 shows that the TCE/DCE concentration increase much more rapidly at SPW-3-1 than at SPW-4. This rapid increase in TCE/DCE is likely due to the presence of nearby TCE DNAPL sources (rapid transformation of TCE to DCE in the dissolved phase likely occurred during the push-pull test, as the soil data in Section 5.7.1 clearly showed that the DNAPL sources were primarily comprised of TCE). The DNAPL volume in the tested volume surrounding SPW-3-1 estimated by the EST model was 2.9 L, which is less than 0.1% of the interrogated pore volume during the push-pull test. Such low levels could not be identified using partition tracers but were identifiable by comparing the bromide and TCE/DCE recoveries and by applying the EST model. Results from both the push-pull test, soil core data, and groundwater data are qualitatively consistent.

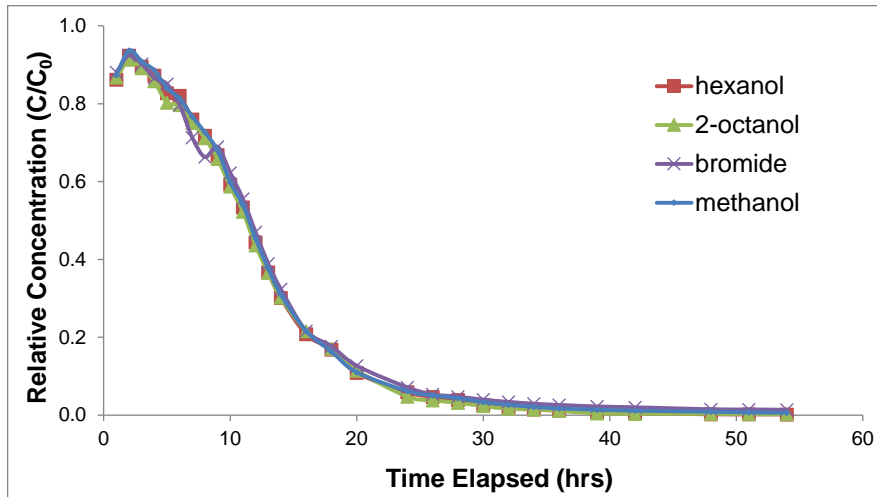

Figure 5.15 Results of the Push-Pull Partitioning Tracer Test at SPW3-1
All tracers co-eluted, suggesting residual DNAPL sources were not present.

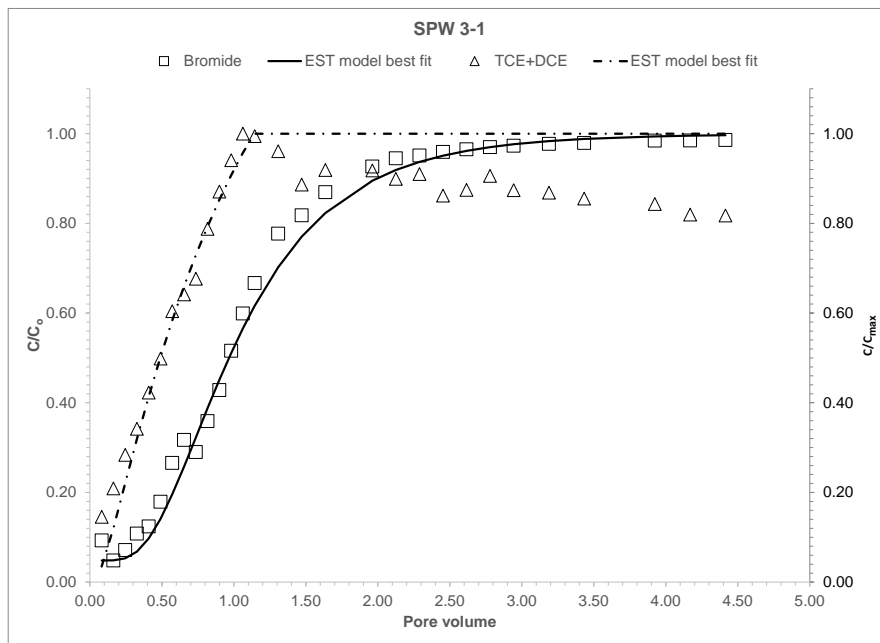

Figure 5.16 EST Model Regressed to Both Bromide and DCE Data during the Push-Pull Test at SPW3-1

6.0 PERFORMANCE ASSESSMENT

6.1 ASSESS EFFECTIVENESS OF DNAPL REMOVAL IN LOWER PERMEABILITY MATERIALS

As discussed in detail in Sections 5.7.1 and 5.7.2.2, DNAPL removal in the lower permeability material likely occurred in one portion of the site (near SMLS 7), but persisted in another portion of the site (near SMLS 1 and SPW3-1). The push-pull partitioning tracer testing performed at SPW3-1 also confirmed the presence of DNAPL. Thus, the combination of discrete monitoring intervals, soil sampling, and push-pull partitioning tracer testing served as useful tools for assessing treatment of DNAPL sources.

6.2 ASSESS LONG-TERM DECHLORINATION ACTIVITY

The complete dechlorination of TCE continued within the demonstration area based on groundwater monitoring data collected up to 3.7 years after cessation of active bioremediation. Continued dechlorination was evidenced by elevated (relative to pre-bioaugmentation) levels of ethene and based on the net carbon isotopic enrichment observed for the chlorinated ethenes as a function of concentration (discussed in Section 5.7.2.2). Thus, both ethene and CSIA data were critical for this assessment.

6.3 DETERMINE DOWNGRADIENT IMPACTS

Monitoring performed at the downgradient PMLS wells (Figure 5.4) verified that chlorinated ethene concentrations decreased since initiation of active bioremediation and have continued to decrease during the post-treatment monitoring period. This decrease likely is due to both mass removal in the source area, and the continued biotic dechlorination that is occurring.

6.4 IDENTIFY THE CHARACTERIZATION AND MONITORING TOOLS THAT WERE MOST CRITICAL FOR PERFORMANCE ASSESSMENT

The ability to monitor discretely in both the lower and higher permeability materials provided key insight with respect to the site conceptual model, and on the nature of the residual DNAPL sources. In addition, the use of carbon isotopic analysis for the chlorinated ethenes was crucial for both verifying and quantifying the extent of dechlorination occurring at the site. Finally, use of both source area and nearby downgradient monitoring locations provided an opportunity to assess the rate of complete dechlorination occurring downgradient of the source area, and the overall impact on groundwater quality.

6.5 ASSESS OVERALL PERFORMANCE WITH RESPECT TO APPLICABILITY TO OTHER DNAPL SOURCE AREAS

An overview of the critical findings of this long-term monitoring study that can be applied to other DNAPL source areas is provided in Appendix B. This information is expected to provide guidance on how long-term monitoring should be applied, and how to utilize long-term dechlorination activity as part of the site remedy.

Page Intentionally Left Blank

7.0 COST ASSESSMENT

7.1 COST MODEL

In order to evaluate the cost of a potential full-scale bioremediation assessment program, costs associated with various aspects of the demonstration were tracked throughout the course of the project. Table 7.1 summarizes the various cost elements and total cost of the demonstration project. The costs have been grouped by categories as recommended in the Federal Remediation Technologies Roundtable (FRTR) Guide to Documenting and Managing Cost and Performance Information for Remediation Projects (FRTR, 1998). Many of the costs shown on this table are a product of the innovative and technology validation aspects of this project, and would not be applicable to a typical site application. Therefore, a separate “discounted costs” column that excludes or appropriately discounts these costs has been included in Table 7.1 to provide a cost estimate for implementing this assessment approach at the same scale as the demonstration (i.e., pilot scale).

Costs associated with the long-term performance assessment following bioaugmentation demonstration were tracked from September 2014 to December 2017. The total cost of the demonstration was \$649,977, which included \$97,277 in capital costs, \$338,125 in operation and maintenance (O&M) costs, and \$214,576 in demonstration-specific costs (cost related to ESTCP requirements, site selection and characterization).

7.1.1 Capital Costs

Capital costs (primarily system design, fabrication, and installation) accounted for \$97,277 (or 15 percent) of the total demonstration costs. As indicated in Table 7.1, these costs exceed what would be expected during a typical remediation project due partially to the ability to stream-line the system design and fabrication process for a more typical project of this scale.

7.1.2 O&M Costs

O&M costs accounted for \$376,440 (or 58 percent) of the total demonstration cost. These costs consisted primarily of groundwater monitoring and soil sampling (including labor, materials and analytical), PFM testing, the PTT, and data management and evaluation costs. Groundwater and soil sampling costs were \$117,034, or 18 percent (%) of total demonstration costs, while the PFM testing costs were \$28,338 (4.4% of total demonstration costs) and PTT costs were \$35,224 (5.4% of total demonstration costs). Analytical costs during the demonstration totaled \$120,545, or 18.5% of the total demonstration costs, due to the extensive performance monitoring activities conducted to effectively validate this technical approach.

Table 7.1 Demonstration Cost Components

| Cost Element | Details | Tracked Demonstration Costs | Discounted Costs ¹ |
|--|-----------------------------------|-----------------------------|-------------------------------|
| CAPITAL COSTS | | | |
| System Design | Labor | \$12,480 | \$8,000 |
| | Subcontractor (CDM Smith) | \$3,725 | \$0 |
| System Fabrication, Installation, and Demobilization | Labor & Travel | \$52,459 | \$40,000 |
| | Equipment & Materials | \$28,613 | \$20,000 |
| Subtotal | | \$97,277 | \$68,000 |
| OPERATION AND MAINTENANCE COSTS | | | |
| Groundwater and Soil Sampling | Labor | \$73,948 | \$55,000 |
| | Materials & Equipment | \$25,300 | \$20,000 |
| | Travel | \$1,068 | \$0 |
| | Subcontractor (CDM Smith) | \$11,174 | \$0 |
| | Subcontractor (driller) | \$3,940 | \$0 |
| | Subcontractor (utility clearance) | \$1,605 | \$0 |
| Passive Flux Meter Testing | Labor | \$9,630 | \$5,000 |
| | Subcontractor (Univ. of Florida) | \$18,708 | \$15,000 |
| Partitioning Tracer Testing | Labor | \$9,630 | \$17,000 |
| | Materials & Equipment | \$3,179 | \$3,000 |
| | Subcontractor (CDM Smith) | \$7,449 | \$0 |
| | Subcontractor (Univ. of Florida) | \$14,966 | \$0 |
| Analytical | In-House Labor | \$47,180 | \$0 |
| | Outside Labs | \$73,366 | \$50,000 |
| Data Management & Evaluation and Quarterly Reporting | Labor | \$34,240 | \$15,000 |
| | Subcontractor (CDM Smith) | \$22,349 | \$0 |
| | Subcontractor (Univ. of Florida) | \$18,709 | \$0 |
| Subtotal | | \$376,440 | \$180,000 |
| OTHER TECHNOLOGY-SPECIFIC COSTS | | | |
| Site Selection | Labor | \$12,840 | \$0 |
| Demonstration Plan/Work Plan | Labor | \$26,750 | \$15,000 |
| | Subcontractor (CDM Smith) | \$7,449 | \$0 |
| | Subcontractor (Univ. of Florida) | \$3,742 | \$0 |
| IPR Meetings | Labor | \$3,210 | \$0 |
| | Subcontractor (CDM Smith) | \$3,726 | \$0 |
| Project Management (financial/administrative) | Labor | \$34,996 | \$15,000 |
| Technology Transfer (conference and meeting presentations, published papers) | Labor | \$5,350 | \$0 |
| | Travel | \$3,398 | \$0 |
| | Subcontractor (CDM Smith) | \$3,742 | \$0 |
| | Subcontractor (Univ. of Florida) | \$3,742 | \$0 |
| Final Report and Final Cost and Performance Report | Labor | \$37,450 | \$20,000 |
| | Subcontractor (CDM Smith) | \$14,899 | \$0 |
| | Subcontractor (Univ. of Florida) | \$14,966 | \$0 |
| Subtotal | | \$176,260 | \$50,000 |
| TOTAL COSTS | | \$649,977 | \$298,000 |

Notes:

¹Discounted costs are defined as estimated costs to implement this technology at the same scale as the demonstration. These costs do not include the technology validation aspects of this ESTCP demonstrations, such as site selection, treatability studies, ESTCP technical transfer requirements, ESTCP demonstration reporting and meeting (IPR) requirements, and preparation of technical and cost and performance reports.

7.1.3 Demonstration-Specific Costs

Other demonstration-specific costs (a portion of which are not expected to be incurred during non-research-oriented remediation projects for the most part) accounted for \$176,260, or 27% of the total demonstration cost. These costs included site selection, preparation of the extensive technical demonstration plan, ESTCP technical transfer requirements (including presenting at technical conferences and publishing manuscripts), ESTCP demonstration reporting and meeting (IPR) requirements, preparation of extensive final technical and cost and performance reports, and financial and administrative project management tasks associated with required government cost reporting and billing.

7.2 COST DRIVERS

7.2.1 General Considerations

The expected cost drivers for the long-term performance assessment following bioaugmentation program, and those that will determine the cost/selection of this assessment technology include the following:

- Depth of the target contaminant zone below ground surface;
- Width, length, and thickness of the target contaminant zone;
- Aquifer lithology and hydrogeology;
- Monitoring well field density and the need to install additional monitoring points;
- Number of sample intervals and associated analytical costs; and
- PTT system O&M costs.

7.2.2 Competing Treatment Technologies

As this long-term performance assessment following bioaugmentation program is not a remediation technology, an assessment versus other treatment technologies is not applicable. Thus, no additional information is provided in this section of the report.

7.3 COST ANALYSIS

Though performing a thorough cost analysis of various competing technologies is not applicable for this demonstration, this section presents a cost estimate to implement a “typical” post-remediation performance assessment, and then quantifies the incremental cost associated with “upgrading” to the long-term performance assessment following bioaugmentation program at a typical site in which bioaugmentation had been applied in a source area.

7.3.1 Base Cost Template

The base case presented in Krug et al. (2009) is modified here as a template for the cost analysis of the assessment program. The base case presents a situation where a shallow, unconfined overburden aquifer is contaminated with residual TCE DNAPL in the source area.

The TCE source area extends to 30 feet bgs (saturated thickness is 20 feet), and is 45 feet long and 30 feet wide, perpendicular to groundwater flow (Figure 7.1). Figure 7.1 shows that eight monitoring wells were installed previously at the site during the site characterization phase and were sampled prior to and during the previously executed bioaugmentation activities. The site characteristics of the specific base case to be used to generate the cost estimate (Section 7.3.2), including aquifer characteristics, well points, and design parameters, are summarized in Table 7.2.

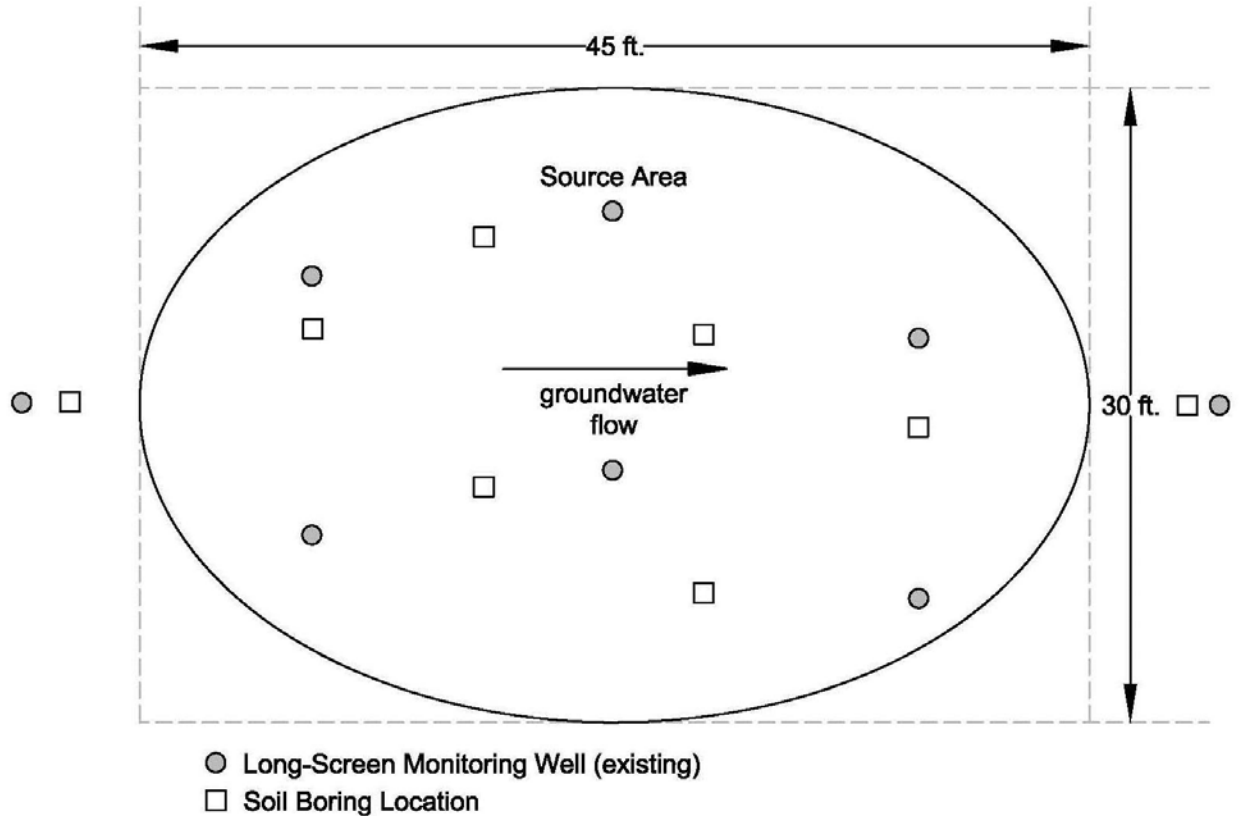

Figure 7.1 Base Plume Characteristics

The following subsection (Section 7.3.2) provides a cost estimate for the incremental cost of “upgrading” from a “typical” post-remediation monitoring program to the long-term performance assessment (similar to what was implemented for this ESTCP demonstration project) following bioaugmentation for the base case. The cost estimate provides insight into the incremental capital and O&M costs to better identify cost drivers for the more technical assessment approach. This will lead to an improved understanding of subsurface conditions, including a more precise picture of contaminant distribution, ultimately leading to potentially substantial remediation cost savings as the project progresses, as subsequent remedial efforts can focus on discrete areas. A second cost estimate is also included in Section 7.3.2, estimating a cost to perform the long-term performance assessment at a source area with twice the treatment area/volume, providing a comparison of the cost per unit volume for the two different sized source areas, showing economies of scale with the larger source area assessment.

Total incremental cost to implement the demonstrated long-term assessment, beyond the cost of the “typical” post-remediation monitoring, was calculated. Net Present Value (NPV) of future costs was not calculated, as the assessment approach is short-term, with no longer term monitoring costs. Specifically excluded from consideration are the costs of pre-remediation site characterization activities, as well as implementation of the bioaugmentation remedy; assuming the costs for these activities would have already been born by the project site prior to implementation of the remedial monitoring approach.

Table 7.2 Summary of Base Case Site Characteristics and Design Parameters

| Design Parameter | Units | Assessment Approach Alternative | |
|--|-------------|---|---|
| | | "Typical" Post-Remediation Performance Assessment following Bioaugmentation | Demonstrated Long-Term Performance Assessment following Bioaugmentation |
| Width of Source Zone Assessment Area | feet | 30 | 30 |
| Length of Source Zone Assessment Area | feet | 45 | 45 |
| Area of Source Zone Assessment Area | square feet | 1,350 | 1,350 |
| Upper Depth of Source Zone Assessment Area | feet | 10 | 10 |
| Lower Depth of Source Zone Assessment Area | feet | 30 | 30 |
| Volume of Source Zone Assessment Area | cubic yards | 1,000 | 1000 |
| Number of Long-Screen Monitoring Wells | each | 8 | 8 |
| Number of Source MLS Monitoring Wells | each | 0 | 3 |
| Number of Plume MLS Monitoring Wells | each | 0 | 1 |
| Number of Sample Intervals per MLS Well | each | 0 | 4 |
| Total Number of Groundwater Monitoring Intervals | each | 8 | 24 |
| Total Number of Soil Boring Locations | each | 8 | 8 |

7.3.2 Long-Term Performance Assessment following Bioaugmentation Program

The demonstrated long-term performance assessment following bioaugmentation program for the base case assumes that the project site will utilize existing and install additional wells (as shown on Figure 7.2), including three source area MLS wells and one plume MLS well. The existing upgradient and downgradient long-screen monitoring wells, as well as the source area long-screen monitoring wells, will remain as monitoring points for the long-term performance assessment program. One groundwater monitoring event would be conducted. Eight soil borings (one upgradient of the source area, six in the source area, and one downgradient of the source area) would be advanced at the locations shown on Figure 7.2 (note that these soil borings would be advanced during the “typical” post-remediation treatment approach, so no incremental cost will be incurred for this activity).

Upon completion of the groundwater monitoring event, push-pull tracer testing would be performed at six well locations, consisting of both long-screened wells and MLS well intervals. Groundwater will be used to mix the tracer solution to be injected (push) and the extracted water (pull) would be collected for off-site disposal.

As summarized in Table 7.3, the incremental estimated total cost to implement this approach beyond the “typical” approach over 3 years for the base case site is \$51,160. A more detailed breakdown of the costs is included in the expanded table presented in Appendix E. The capital cost including the installation of source and plume MLS wells is approximately \$24,800. The O&M costs of conducting the push-pull testing is estimated to be \$15,420, while the cost of performing the groundwater sampling event (including sampling crew labor and laboratory analytical costs for analysis of VOCs, anions, dissolved metals, volatile fatty acids, and CSIA) is estimated to be \$10,940. Based on a total assessment zone volume of 1,000 cubic yards (yd³), the unit volume cost to implement this “upgraded” assessment is \$51/yd³.

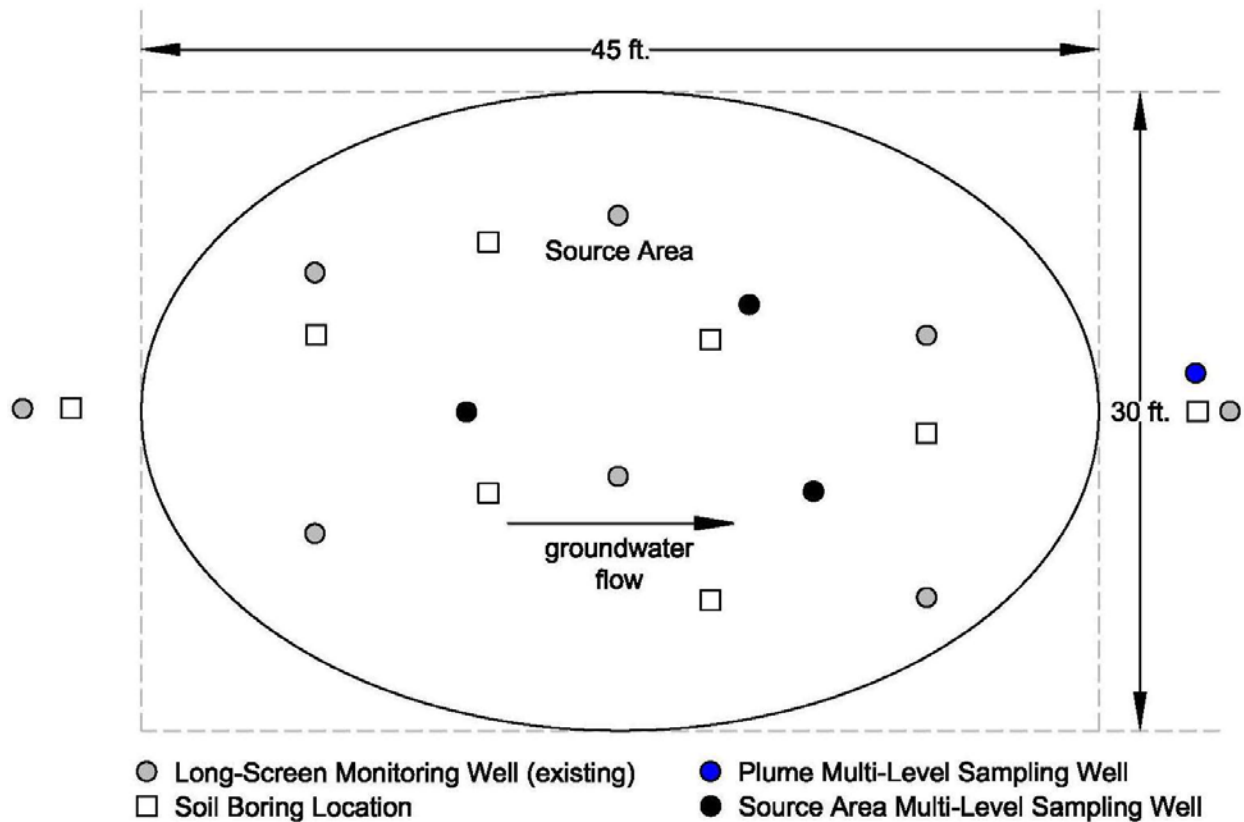

Figure 7.2 Long-Term Performance Assessment following Bioaugmentation

Table 7.3 Incremental Cost Estimate to "Up-Grade" to the Demonstrated Long-Term Performance Assessment following Bioaugmentation for Base Case

| | | |
|--|-------------------------|------------------------|
| <i>Capital Costs</i> | | <i>\$24,800</i> |
| Well Installation | | |
| | Mobilization | \$3,000 |
| | Oversight Labor | \$4,800 |
| | Subcontract Driller | \$12,000 |
| | Subcontract Surveyor | \$2,000 |
| | Materials/Consumables | \$1,000 |
| | Utilities/Fuel | \$500 |
| | Waste Disposal | \$1,500 |
| <i>Push-Pull Tracer Testing</i> | | <i>\$15,420</i> |
| | Labor (Field Testing) | \$7,680 |
| | Labor (Analytical) | \$3,060 |
| | Labor (Data Management) | \$680 |
| | Equipment/Parts | \$1,000 |
| | Materials/Consumables | \$1,000 |
| | Utilities/Fuel | \$500 |
| | Waste Disposal | \$1,500 |
| <i>Groundwater Monitoring Costs</i> | | <i>\$10,940</i> |
| | Labor (Sample Crew) | \$3,200 |
| | Analytical | \$7,540 |
| | Sampling Equipment | \$200 |
| TOTAL | | <i>\$51,160</i> |

7.3.2.1 Assessment Size Implication on Unit Volume Cost

A second cost estimate was also generated for the performance of the long-term performance assessment at a source area with twice the treatment area/volume, to provide a comparison of the cost per unit volume for the two different sized source areas. Table 7.4 and associated Figure 7.3 present a case where the treatment volume has been doubled to 2,000 yd³. In this case, two additional source area MLS wells were added.

Table 7.4 Summary of Expanded Zone Site Characteristics and Design Parameters

| Design Parameter | Units | Demonstrated Long-Term Performance Assessment following Bioaugmentation (Assessment Volume = 2,000 yd ³) |
|--|-------------|---|
| Width of Source Zone Assessment Area | feet | 45 |
| Length of Source Zone Assessment Area | feet | 60 |
| Area of Source Zone Assessment Area | square feet | 2,700 |
| Upper Depth of Source Zone Assessment Area | feet | 10 |
| Lower Depth of Source Zone Assessment Area | feet | 30 |
| Volume of Source Zone Assessment Area | cubic yards | 2,000 |
| Number of Long-Screen Monitoring Wells | each | 8 |
| Number of Source MLS Monitoring Wells | each | 5 |
| Number of Plume MLS Monitoring Wells | each | 1 |
| Number of Sample Intervals per MLS Well | each | 4 |
| Total Number of Groundwater Monitoring Intervals | each | 32 |
| Total Number of Soil Boring Locations | each | 8 |

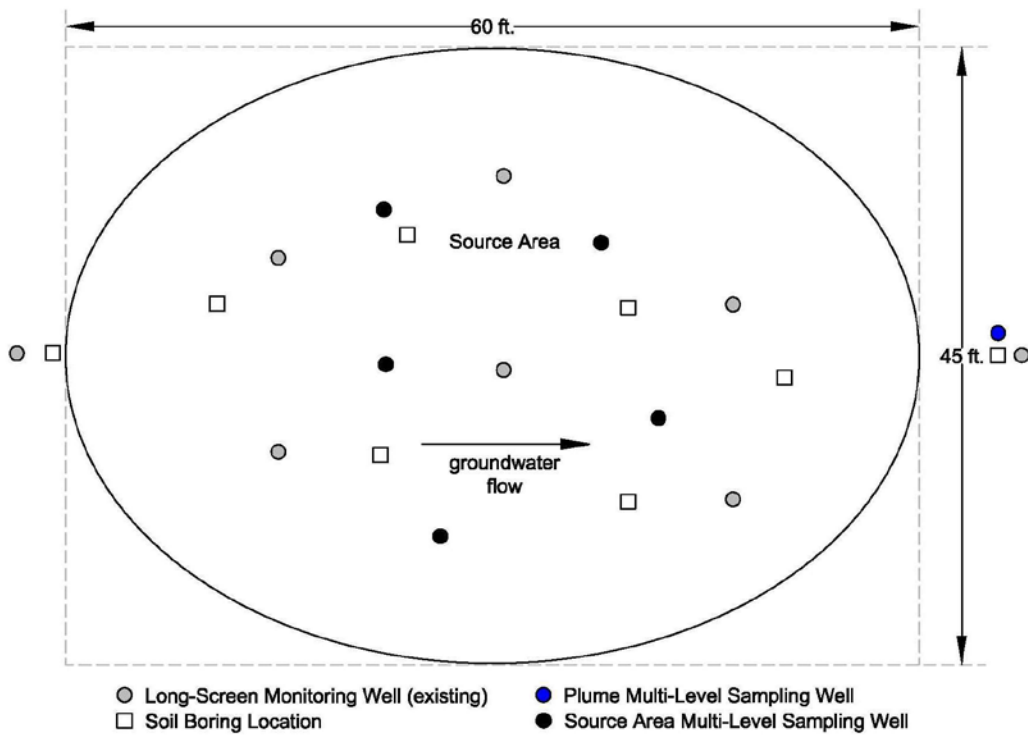

Figure 7.3 Expanded Zone Long-Term Performance Assessment following Bioaugmentation

As summarized in Table 7.5, the incremental estimated total cost to implement this approach beyond the “typical” approach for the case where the assessment zone is expanded to 2,000 yd³ is \$64,205. A more detailed breakdown of the costs is included in the expanded table presented in Appendix E. The capital cost including the installation of source and plume MLS wells is approximately \$32,900. The O&M costs of conducting the push-pull testing is estimated to be \$15,420, while the cost of performing the groundwater sampling event (including sampling crew labor and laboratory analytical costs for analysis of VOCs, anions, dissolved metals, volatile fatty acids, and CSIA) is estimated to be \$15,885. Based on a total assessment zone volume of 2,000 cubic yards (yd³), the unit volume cost to implement this “upgraded” assessment on the expanded assessment zone is \$32/yd³. Compared to the unit volume cost of \$51/yd³ for the base case, economies of scale are evident with significantly lower unit volume costs for the larger source area assessment.

Table 7.5 Incremental Cost Estimate to "Up-Grade" to the Demonstrated Long-Term Performance Assessment following Bioaugmentation for Expanded Zone Case

| | | |
|--|--------------------------|------------------------|
| <i>Capital Costs</i> | | <i>\$32,900</i> |
| Well Installation | | |
| | Mobilization | \$3,000 |
| | Oversight Labor | \$6,400 |
| | Subcontract Driller | \$18,000 |
| | Subcontract Surveyor | \$2,000 |
| | Materials/Consumables | \$1,000 |
| | Utilities/Fuel | \$500 |
| | Waste Disposal | \$2,000 |
| <i>Push-Pull Tracer Testing</i> | | <i>\$15,420</i> |
| | Labor (System Operation) | \$7,680 |
| | Labor (Analytical) | \$3,060 |
| | Labor (Data Management) | \$680 |
| | Equipment/Parts | \$1,000 |
| | Materials/Consumables | \$1,000 |
| | Utilities/Fuel | \$500 |
| | Waste Disposal | \$1,500 |
| <i>Groundwater Monitoring Costs</i> | | <i>\$15,885</i> |
| | Labor (Sample Crew) | \$4,800 |
| | Analytical | \$10,785 |
| | Sampling Equipment | \$300 |
| TOTAL | | <i>\$64,205</i> |

Page Intentionally Left Blank

8.0 IMPLEMENTATION ISSUES

The primary issues related to implementation of the long-term performance assessment at a site (Alameda Point) where bioaugmentation was used to treat a highly characterized overburden DNAPL source area were:

- ***PFM Data Interpretation.*** PFM data interpretation must be carefully performed, as the Darcy velocity varied spatially and temporally, which had an impact on contaminant flux rates. Contaminant fluxes must be normalized to the groundwater flux in order to assess changes in contaminant mass discharge due to source removal.
- ***Biofouling within injection wells.*** Biofouling has often been an issue for active bioremediation systems. Not surprisingly, biofouling of the previously utilized injection wells during the bioaugmentation activities was a challenge in this demonstration. As discussed in Section 5.4.4, upon initial water testing of the recirculation system components, it was discovered that the yield of the injection wells was very low (approximately 0.04 gal/min); too low for implementation of the recirculation PTT. Because all the underground and well connection piping (constructed as part of SERDP Project ER-1613) was glued, the costs to excavate, disconnect, and reconstruct this piping to access the wells for rehabilitation were too great and beyond the scope of this current project. Approaches using automated or periodic biocide treatment to limit microbial biomass accumulation within injection wells is likely needed to mitigate this issue in future bioremediation applications. Construction of the injection and extraction well heads should be done in such a manner that the piping can be easily removed for periodic well rehabilitation efforts, if/when needed.

Page Intentionally Left Blank

9.0 REFERENCES

- Abe Y, Aravena R, Zopfi J, Shouakar-Stash O, Cox E, Roberts JD, Hunkeler D. 2009. Carbon and chlorine isotope fractionation during aerobic oxidation and reductive dechlorination of vinyl chloride and cis-1,2-dichloroethene. *Environmental Science & Technology* 43:101–107.
- Adamson, D.T., J.M. McDade, and J.B. Hughes. Inoculation of a DNAPL source zone to initiate reductive dechlorination of PCE. *Environmental Science & Technology*. 2003, 37, 2525-2533.
- Adamson, D.T. and C.J. Newell. 2009. Support of source zone bioremediation through endogenous biomass decay and electron donor recycling. *Bioremediation Journal* 13:29-40.
- Amonette, J.E. and Templeton, J.C. 1998. Improvements to the quantitative assay of nonrefractory minerals for Fe (II) and total Fe using 1, 10-phenanthroline. *Clays and Clay Minerals*, 46: 51-62.
- Amos, B.K., E.J. Suchomel, K.D. Pennell, and F.E. Löffler. Microbial activity and distribution during enhanced contaminant dissolution from a NAPL source zone. *Water Res.* 2008, 42, 2963-2974.
- Amos, B.K., E.J. Suchomel, K.D. Pennell, and F.E. Löffler. Spatial and temporal distributions of *Geobacter lovleyi* and *Dehalococcoides* spp. during bioenhanced PCE-DNAPL dissolution. *Environmental Science & Technology*. 2009, 43, 1977-1985.
- Annable, M.D., P.S.C. Rao, W.D. Graham, K. Hatfield, and A.L. Wood. Use of Partitioning Tracers for Measuring Residual NAPL: Results from a Field-Scale Test. *Journal of Environmental Engineering*, Vol. 124, No.6, 1998, pp. 498-503.
- Annable, M.D., K. Hatfield, J. Cho, H. Klammler, B.L. Parker, J.A. Cherry, and P.S.C. Rao. Field-Scale Evaluation of the Passive Flux Meter for Simultaneous Measurement of Groundwater and Contaminant Fluxes, *Environmental Science & Technology*. 2005, 39, 7194-7201.
- Bloom, Y., R. Aravena, D. Hunkeler, E. Edwards, and S.K. Frape. 2000. Carbon isotope fractionation during microbial dechlorination of trichloroethene, cis-1,2-dichloroethene, and vinyl chloride: implications for assessment of natural attenuation. *Environmental Science & Technology* 34:2768-2772.
- CB&I Federal Services (CBI), CDM Smith. Final Demonstration Plan: Long Term Performance Assessment at a Highly Characterized and Instrumented DNAPL Source Area following Bioaugmentation. Alameda, California. February 2015.
- Chapman, S. W. & Parker, B. L. Plume persistence due to aquitard back diffusion following dense nonaqueous phase liquid source removal or isolation. *Water Resources Research* 41(12), W12411 (2005).
- FRTR (Federal Remediation Technologies Roundtable). 1998. Guide to Documenting and Managing Cost and Performance Information for Remediation Projects, Revised Version. EPA 542-B-98-007.

- Fullerton, H., M. Crawford, A. Bakken, D.L. Freedman, S.H. Zinder. 2013. Anaerobic oxidation of ethene coupled to sulfate reduction in microcosms and enrichment cultures. *Environmental Science & Technology* 47:12374-12381.
- Glover, K.C., J. Munakata-Marr, and T.H. Illangasekare. Biologically enhanced mass transfer of tetrachloroethene from DNAPL in source zones: experimental evaluation and influence of pool morphology. *Environmental Science & Technology*. 2007, 41, 1384-1389.
- Gossett, J.M. 2010. Sustained aerobic oxidation of vinyl chloride at low oxygen concentrations. *Environmental Science & Technology* 44:1405-1411.
- Hartog, N.; Cho, J.; Parker, B.L.; Annable, M.D. 2010. Characterization of a heterogeneous DNAPL source zone in the Borden aquifer using partitioning and interfacial tracers: residual morphologies and background sorption. *Journal of Contaminant Hydrology* 115, 79-89.
- Hatfield, K., Annable, M., Cho, J., Rao, P.S.C. and Klammler, H., 2004. A direct passive method for measuring water and contaminant fluxes in porous media. *Journal of Contaminant Hydrology*, 75(3): 155-181.
- Hatzinger, P.B., J.K. Bohlke and N.C. Sturchio. 2013. Application of stable isotope ratio analysis for biodegradation monitoring in groundwater. *Cur. Opinion. Biotechnol.* 24, 542-549.
- He, Y.T., J.T. Wilson, and R.T. Wilkin, R.T. 2015. Review of Abiotic Degradation of Chlorinated Solvents by Reactive Iron Minerals in Aquifers. *Ground Water Monitoring & Remediation* 35:57-75.
- Hood ED, Major DW, Quinn JW, Yoon W-S, Gavaskar A, Edwards EA (2008) Demonstration of enhanced bioremediation in a TCE source area at Launch Complex 34, Cape Canaveral Air Force Station. *Ground Water Monitoring & Remediation* 28:98–107.
- Hunkeler D, Abe Y, Broholm MM, Jeannotat S, Westergaard C, Suhr Jacobsen C, Aravena R, Bjerg PL (2011) Assessing chlorinated ethene degradation in a large scale contaminant plume by dual carbon–chlorine isotope analysis and quantitative PCR. *Journal of Contaminant Hydrology* 119:69–79.
- ITRC (Interstate Technology & Regulatory Council). In situ bioremediation of chlorinated ethene DNAPL source zones: case studies. 2007, BioDNAPL-2. Washington, D.C.
- ITRC (Interstate Technology & Regulatory Council). 2013. Environmental Molecular Diagnostics, New Site Characterization and Remediation Enhancement Tools. EMD-2. Washington, D.C.: Interstate Technology & Regulatory Council, Environmental Molecular Diagnostics Team. www.itrcweb.org.
- Jawitz, J.W., Fure, A.D., Demmy, G.G., Berglund, S., Rao, P.S.C., 2005. Groundwater contaminant flux reduction resulting from nonaqueous phase liquid mass reduction. *Water Resource Research*. 41 (10), W10408.

- Krug, T.A., C. Wolfe, R.D. Norris, and C.J. Winstead. 2009. Cost Analysis of In Situ Perchlorate Bioremediation Technologies. In *In Situ Remediation of Perchlorate in Groundwater*. H.F. Stroo and C.H. Ward, Eds. SERDP/ESTCP Environmental Remediation Technology.
- Meckenstock, R.U., Morasch, B., Griebler, C., Richnow, H.H. 2004. Stable Isotope Fractionation Analysis as a Tool to Monitor Biodegradation in Contaminated Aquifers. *Journal of Contaminant Hydrology*, 75(3-4): 215-255.
- Morrill, P.L., Sleep, B.E., Seepersad, D.J., McMaster, M.L., Hood, E.D., LeBron, C., Major, D.W., Edwards, E.A., Sherwood-Lollar, B. 2009. Variations in Expression of Carbon Isotope Fractionation of Chlorinated Ethenes during Biologically Enhanced PCE Dissolution Close to a Source Zone. *Journal of Contaminant Hydrology*, 110(1-2): 60-71.
- Parker, B.L., Cherry, J.A., Chapman, S.W., Guilbeault, M.A., 2003. Review and analysis of chlorinated solvent dense nonaqueous phase liquid distributions in five sandy aquifers. *Vadose Zone J.* 2, 116-137.
- Schaefer, C.E., R.M. Towne, S. Vainberg, J.E. McCray, and R.J. Steffan. 2010. Bioaugmentation for treatment of dense non-aqueous phase liquid in fractured sandstone blocks. *Environmental Science & Technology*, 44:4958-4964.
- Schaefer, C.E., R.M. Towne, D.R. Lippincott, V. Lazouskaya, T.B. Fischer, M.E. Bishop, and H. Dong. 2013. Coupled diffusion and abiotic reaction of trichloroethene in minimally disturbed rock matrices. *Environmental Science and Technology* 47: 4291–4298.
- Schaefer, C.E., R.M. Towne, D.R. Lippincott, P. Lacombe, M.E. Bishop, and H. Dong. 2015. Abiotic Dechlorination in Rock Matrices Impacted by Long-Term Exposure to TCE. *Chemosphere* 119:744-749.
- Schroth, M.H., Istok, J.D., Haggerty, R., 2000. In situ evaluation of solute retardation using single-well push-pull tests. *Advance Water Resource*. 24 (1), 105-117.
- Shaw Environmental (Shaw). Final Treatability Study Report on Enhanced Bioremediation Source Area Treatment at Plume 4-1. Alameda, California. December 2013.
- Sherwood-Lollar, B. Slater, G.F., Sleep, B., Witt, M., Klecka, G.M., Harkness, M., Spivak, J., 2001. Stable Carbon Isotope Evidence for Intrinsic Bioremediation of Tetrachloroethene and Trichloroethene at Area 6, Dover Air Force Base. *Environmental Science & Technology*, 35(2): 261-269.
- Sleep, B.E., A.J. Brown, B.S. Lollar. 2005. Long-term tetrachloroethene degradation sustained by endogenous cell decay. *Journal of Environmental Engineering Science* 4:11-17.
- Smith, R.L., Harvey, R.W., LeBlanc, D.R. 1991. Importance of Closely Spaced Vertical Sampling in Delineating Chemical and Microbiological Gradients in Groundwater Studies. *Journal of Contaminant Hydrology*, 7(3): 285-300.
- Tetra Tech Environmental Management, Inc., 1999, Draft Clean II-Operable Unit-2 Remedial Investigation Report, Alameda Point, Alameda, California, June.

- Thullner, M., Centler, F., Richnow, H.H., Fischer, A. 2012. Quantification of Organic Pollutant Degradation in Contaminated Aquifers using Compound Specific Stable Isotope Analysis – Review of Recent Developments. *Organic Geochemistry*, 42(12): 1440-1460.
- Torlapati, J., Clement, T.P., Schaefer, C.E., Lee, K.K. 2012. Modeling Dehalococcoides Sp. augmented bioremediation in a single fracture system. *Ground Water Monitoring and Remediation*, DOI:10.1111/j.1745-6592.2011.01392.x.
- United States Environmental Protection Agency (USEPA). Demonstration of bioaugmentation of DNAPL through biostimulation and bioaugmentation at Launch Complex 34 Cape Canaveral Air Force Station, Florida. 2004, EPA/540/R-07/007.
- Wang, F., Annable, M.D., Jawitz, J.W., 2013. Field-scale prediction of enhanced DNAPL dissolution based on partitioning tracers. *Journal of Contaminant Hydrology* 152: 145-158.
- Wang, F., Annable, M.D., Schaefer, C.E., Ault, T.D., Cho, J., Jawitz, J.W., 2014. Enhanced Aqueous Dissolution of a DNAPL Source to Characterize the Source Strength Function. *Journal of Contaminant Hydrology* 169: 75-89.

APPENDIX A POINTS OF CONTACT

| Point of Contact Name | Organization Name Address | Phone Fax Email | Role in Project |
|-----------------------|--|--|--|
| Charles Schaefer | CDM Smith 110 Fieldcrest Avenue, #8 6th Floor Edison, NJ 08837 | 732-590-4633 direct 609-332-0346 cell schaeferce@cdmsmith.com | Principal Investigator |
| Graig Lavorgna | APTIM 17 Princess Road Lawrenceville, NJ 08648 | 609-895-5343 direct 908-309-7651 cell graug.lavorgna@aptim.com | Project Manager Project Engineer |
| Michael Annable | University of Florida 1949 Stadium Road 365 Weil Hall Gainesville, FL 32611 | 352-392-3294 direct 352-278-8693 cell annable@ufl.edu | Technical Support |
| Alexander Haluska | University of Florida 1949 Stadium Road 502 Weil Hall Gainesville, FL 32611 | 763-639-7548 direct haluska@ufl.edu | Technical Support |
| Andrea Leeson | SERDP/ESTCP 901 N Stuart Street Suite 303 Arlington VA 22203 | 703-696-2118 direct 703-696-2114 fax andrea.leeson@osd.mil | ESTCP Environmental Restoration Program Manager |
| Douglas Delong | US Navy BRAC PMO West 1 Avenue of the Palms Suite 161 San Francisco, CA 94130 | 415-743-4713 main douglas.delong_ctr@navy.mil | Environmental Compliance, Safety & Security Manager (Alameda Point) |

Page Intentionally Left Blank

**APPENDIX B BIOAUGMENTATION FOR TREATMENT OF DNAPL
SOURCES: INSIGHTS FROM ALAMEDA POINT PLUME
4-1**

Bioaugmentation for Treatment of DNAPL Sources:

Insights from Alameda Point Plume 4-1

The following questions were addressed as part of the long-term post-bioaugmentation evaluation in the DNAPL source area within Plume 4-1 at Alameda Point, CA as part of ESTCP Project ER-201428.

I. What tools were most useful for treatment design?

Characterization of the DNAPL source area, as well as performance monitoring (verification of amendment delivery, determination of transformation products and dechlorination rates), was highly dependent upon determining the location of the DNAPL sources relative to the flow field. For initial screening of potential locations of DNAPL, use of a membrane interface probe (MIP) was extremely useful. Soil core screening using a hand-held photoionization detector, followed by selective soil sampling for chlorinated ethene analysis, served as an effective approach for further identifying and characterizing DNAPL sources. Use of a hydraulic profiling tool (HPT) to determine (semi-quantitatively) the permeability/flow field also served to help develop a conceptual site model for the source area.

The information described above provided the information needed to install the appropriate monitoring locations within the source area. Discretely-screened multi-level sampling (MLS) wells proved very useful for assessing both short- and long-term remedial performance. It is recommended that such discrete monitoring be used within the specific location where DNAPL source reside, especially if the DNAPL sources are in lower permeability materials.

II. What monitoring should be performed to ensure treatment effectiveness?

The use of MLS wells, particularly those located adjacent to DNAPL sources, were useful for confirming proper distribution of amendment and evaluating dissolution/dechlorination. Specific monitoring/testing that was performed at these MLS wells that were useful in assessing treatment effectiveness included:

- Contaminant rebound monitoring (both short-term and long-term)
- Compound specific isotopic analysis (CSIA) for carbon. This information was used to confirm complete dechlorination in the absence of appreciable ethene/ethane.
- Partitioning tracer testing (PTT). PTT, whether in the form of forced gradient tracer or push-pull tests, served as a means to confirm and quantify DNAPL both before and after treatment.

III. What are the expected DNAPL dissolution and dechlorination rates

While the DNAPL dissolution rates during the active bioaugmentation treatment that was performed at Alameda Point Plume 4-1 source area were not readily determined, groundwater monitoring of chlorinated ethene levels coupled with carbon CSIA analyses performed during the long-term dissolution provided an estimate of the overall DNAPL dissolution and dechlorination rate. The observed overall dechlorination rate constant measured during the long-term evaluation (3.5 years following active bioremediation) was 0.01 day^{-1} . With both *Dehalococcoides sp.* and ethene levels several times higher during active bioremediation than at the end of the long-term rebound monitoring, it is likely that the DNAPL dissolution/dechlorination rate constant during active treatment was greater than that measured during this long-term rebound study.

IV. What groundwater remedial levels are attainable?

At locations where measureable DNAPL residual was still present (based on soil core data and/or PTT), bioaugmentation had only marginal impacts on groundwater quality with respect to removal of chlorinated ethenes (sum of TCE + DCE + VC). However, in locations where residual DNAPL sources had been removed (via bioremediation and the preceding enhanced flushing), total chlorinated ethene concentrations decreased by approximately 1 order of magnitude in groundwater. Despite this decrease, chlorinated ethene levels were orders of magnitude above regulatory levels.

This order of magnitude decrease was attained with only 4 months of active (electron donor addition while recirculating groundwater), followed by 3.5 years of post-treatment natural attenuation. It is likely that the extent of chlorinated ethene decrease in groundwater would have been greater if a longer active bioremediation timeframe was employed.

V. What are reasonable expectations with respect to decrease in contaminant mass discharge from the source area?

Chlorinated ethene mass discharge echoed the changes observed in groundwater chlorinated ethene concentrations, where approximately a 1 order of magnitude decrease was observed where residual DNAPL had been removed, while little to no decreases were observed where residual DNAPL sources remained.

VI. How can treatment scale and timeframe be more effectively designed considering downgradient amendment migration and/or post-treatment reductive dechlorination?

Long-term (post active treatment) groundwater monitoring results showed that complete dechlorination of the chlorinated ethenes was occurring along the flow path from the source area to monitoring locations located approximately 10 feet downgradient of where bioremediation was performed. This result suggests that a treatment “halo” of at least 10 feet was attained, and that this additional reaction residence time can be used to determine the expected contaminant mass discharge emanating from the treatment zone.

Perhaps more importantly, the long-term groundwater monitoring showed that active dechlorination continued, with an observed overall dechlorination rate constant of 0.01 day^{-1} , maintained for up to 3.5 years. Assuming that this rate constant has been maintained since the end of active treatment, and assuming a constant chlorinated ethene concentration (maintained by the presence of DNAPL) near SMLS 1-3 of $1,600 \mu\text{M}$, chlorinated ethene soil concentrations near SMLS 1-3 would have decreased by approximately 500 mg/kg since the end of active bioremediation. This decrease represents approximately 25% of the DNAPL levels currently near SMLS 1-3 and soil boring location DPC-20. Accounting for this, post-treatment attenuation and DNAPL removal would allow for a reduction in the time and resources needed for active treatment.

VII. To what extent is long-term monitoring required to properly assess treatment of DNAPL sources in unconsolidated media?

Monitoring results performed within several months of the cessation of active bioremediation were, for monitoring locations screened adjacent to remaining residual DNAPL sources, consistent with monitoring results attained 3.5 years following treatment with respect to chlorinated ethene levels. Thus, discrete monitoring locations located adjacent to DNAPL sources provide relatively rapid feedback with respect to untreated sources and contaminant rebound.

However, at monitoring locations not located and discretely screened in remaining DNAPL sources, results between the short term (several months) and long-term (3.5 years) rebound monitoring were not always consistent. Rebound was not observed until years after cessation of active treatment at some locations, likely due to the time needed for contaminants to migrate within the source area and/or decreases in microbial dechlorination activity. Thus, caution must be taken when relying solely on short-term rebound data for overall remedial assessment, especially if discretely screening monitoring locations located in DNAPL source areas are not available.

Page Intentionally Left Blank

APPENDIX C SOIL ANALYTICAL DATA SUMMARY TABLES

APPENDIX C.1: SOIL ANALYTICAL DATA SUMMARY (VOCs)

| Sample ID | DPC-19-17.3 | DPC-19-17.6 | DPC-19-17.8 | DPC-19-18 | DPC-20-19 | DPC-20-19.3 | DPC-20-19.4 | DPC-20-19.5 | DPC-20-19.6 | DPC-20-19.7 | DPC-20-20 | DPC-20-20.6 | DPC-20-20.11 | DPC-20-21 | DPC-20-21.6 | DPC-20-22.2 | DPC-21-17 | DPC-21-17.3 |
|-----------------------------|-------------|-------------|-------------|----------------|----------------|-----------------|-------------|-------------|------------------|-------------|-----------------|----------------|--------------|----------------|----------------|-------------|----------------|-------------|
| Sampling Date | 4/28/2015 | 4/28/2015 | 4/28/2015 | 4/28/2015 | 4/27/2015 | 4/27/2015 | 4/27/2015 | 4/27/2015 | 4/27/2015 | 4/27/2015 | 4/27/2015 | 4/27/2015 | 4/27/2015 | 4/27/2015 | 4/27/2015 | 4/27/2015 | 4/27/2015 | 4/27/2015 |
| VOCs (GC/MS) | µg/kg | µg/kg | µg/kg | µg/kg | µg/kg | µg/kg | µg/kg | µg/kg | µg/kg | µg/kg | µg/kg | µg/kg | µg/kg | µg/kg | µg/kg | µg/kg | µg/kg | µg/kg |
| dichlorodifluoromethane | -- | -- | -- | 436 U | 529 U | 414 U | -- | -- | 369 U | -- | 462 U | 410 U | -- | 404 U | 368 U | -- | 638 U | -- |
| chloromethane | -- | -- | -- | 436 U | 529 U | 414 U | -- | -- | 369 U | -- | 462 U | 410 U | -- | 404 U | 368 U | -- | 638 U | -- |
| vinyl chloride | -- | -- | -- | 436 U | 6840 D | 6920 D | -- | -- | 10700 D | -- | 4530 D | 536 D | -- | 404 U | 368 U | -- | 1330 D | -- |
| bromomethane | -- | -- | -- | 436 U | 529 U | 414 U | -- | -- | 369 U | -- | 462 U | 410 U | -- | 404 U | 368 U | -- | 638 U | -- |
| chloroethane | -- | -- | -- | 436 U | 529 U | 414 U | -- | -- | 369 U | -- | 462 U | 410 U | -- | 404 U | 368 U | -- | 638 U | -- |
| trichlorofluoromethane | -- | -- | -- | 436 U | 529 U | 414 U | -- | -- | 369 U | -- | 462 U | 410 U | -- | 404 U | 368 U | -- | 638 U | -- |
| 1,1-dichloroethylene | -- | -- | -- | 436 U | 529 U | 414 U | -- | -- | 198 JD | -- | 462 U | 410 U | -- | 404 U | 368 U | -- | 638 U | -- |
| methylene chloride | -- | -- | -- | 436 U | 529 U | 414 U | -- | -- | 369 U | -- | 462 U | 410 U | -- | 404 U | 368 U | -- | 638 U | -- |
| trans-1,2-dichloroethylene | -- | -- | -- | 436 U | 529 U | 414 U | -- | -- | 502 D | -- | 462 U | 410 U | -- | 404 U | 368 U | -- | 638 U | -- |
| 1,1-dichloroethane | -- | -- | -- | 436 U | 529 U | 414 U | -- | -- | 369 U | -- | 462 U | 410 U | -- | 404 U | 368 U | -- | 638 U | -- |
| 2,2-dichloropropane | -- | -- | -- | 436 U | 529 U | 414 U | -- | -- | 369 U | -- | 462 U | 410 U | -- | 404 U | 368 U | -- | 638 U | -- |
| cis 1,2- dichloroethylene | -- | -- | -- | 78.4 JD | 69900 D | 79400 D | -- | -- | 118000 D | -- | 49000 D | 4130 D | -- | 260 JD | 307 JD | -- | 1730 D | -- |
| bromochloromethane | -- | -- | -- | 436 U | 529 U | 414 U | -- | -- | 369 U | -- | 462 U | 410 U | -- | 404 U | 368 U | -- | 638 U | -- |
| chloroform | -- | -- | -- | 95.9 JD | 114 JD | 414 U | -- | -- | 369 U | -- | 462 U | 77 JD | -- | 80.0 JD | 76.6 JD | -- | 638 U | -- |
| 1,1,1-trichloroethane | -- | -- | -- | 436 U | 529 U | 414 U | -- | -- | 369 U | -- | 462 U | 410 U | -- | 404 U | 368 U | -- | 638 U | -- |
| carbon tetrachloride | -- | -- | -- | 436 U | 529 U | 414 U | -- | -- | 369 U | -- | 462 U | 410 U | -- | 404 U | 368 U | -- | 638 U | -- |
| 1,1-dichloropropene | -- | -- | -- | 436 U | 529 U | 414 U | -- | -- | 369 U | -- | 462 U | 410 U | -- | 404 U | 368 U | -- | 638 U | -- |
| benzene | -- | -- | -- | 436 U | 529 U | 414 U | -- | -- | 369 U | -- | 462 U | 410 U | -- | 404 U | 368 U | -- | 638 U | -- |
| 1,2-dichloroethane | -- | -- | -- | 436 U | 529 U | 414 U | -- | -- | 369 U | -- | 462 U | 410 U | -- | 404 U | 368 U | -- | 638 U | -- |
| trichloroethylene | -- | -- | -- | 232 JD | 34600 D | 333000 D | -- | -- | 2310000 D | -- | 482000 D | 9030 D | -- | 3300 D | 616 D | -- | 334 JD | -- |
| 1,2-dichloropropane | -- | -- | -- | 436 U | 529 U | 414 U | -- | -- | 369 U | -- | 462 U | 410 U | -- | 404 U | 368 U | -- | 638 U | -- |
| dibromomethane | -- | -- | -- | 436 U | 529 U | 414 U | -- | -- | 369 U | -- | 462 U | 410 U | -- | 404 U | 368 U | -- | 638 U | -- |
| bromodichloromethane | -- | -- | -- | 436 U | 529 U | 414 U | -- | -- | 369 U | -- | 462 U | 410 U | -- | 404 U | 368 U | -- | 638 U | -- |
| cis-1,3-dichloropropene | -- | -- | -- | 436 U | 529 U | 414 U | -- | -- | 369 U | -- | 462 U | 410 U | -- | 404 U | 368 U | -- | 638 U | -- |
| toluene | -- | -- | -- | 436 U | 529 U | 414 U | -- | -- | 470 D | -- | 462 U | 410 U | -- | 404 U | 368 U | -- | 638 U | -- |
| trans-1,3-dichloropropene | -- | -- | -- | 436 U | 529 U | 414 U | -- | -- | 369 U | -- | 462 U | 410 U | -- | 404 U | 368 U | -- | 638 U | -- |
| 1,1,2-trichloroethane | -- | -- | -- | 436 U | 529 U | 414 U | -- | -- | 369 U | -- | 462 U | 410 U | -- | 404 U | 368 U | -- | 638 U | -- |
| tetrachloroethylene | -- | -- | -- | 436 U | 529 U | 132 JD | -- | -- | 1250 D | -- | 183 JD | 410 U | -- | 404 U | 368 U | -- | 638 U | -- |
| 1,3-dichloropropane | -- | -- | -- | 436 U | 529 U | 414 U | -- | -- | 369 U | -- | 462 U | 410 U | -- | 404 U | 368 U | -- | 638 U | -- |
| dibromochloromethane | -- | -- | -- | 436 U | 529 U | 414 U | -- | -- | 369 U | -- | 462 U | 410 U | -- | 404 U | 368 U | -- | 638 U | -- |
| 1,2-dibromoethane | -- | -- | -- | 436 U | 529 U | 414 U | -- | -- | 369 U | -- | 462 U | 410 U | -- | 404 U | 368 U | -- | 638 U | -- |
| chlorobenzene | -- | -- | -- | 436 U | 186 JD | 526 D | -- | -- | 713 D | -- | 462 U | 3590 D | -- | 150 JD | 120 JD | -- | 257 JD | -- |
| 1,1,1,2-tetrachloroethane | -- | -- | -- | 436 U | 529 U | 414 U | -- | -- | 369 U | -- | 462 U | 410 U | -- | 404 U | 368 U | -- | 638 U | -- |
| ethylbenzene | -- | -- | -- | 436 U | 529 U | 414 U | -- | -- | 194 JD | -- | 462 U | 410 U | -- | 404 U | 368 U | -- | 638 U | -- |
| xylenes (m/p) | -- | -- | -- | 436 U | 529 U | 141 JD | -- | -- | 1003 D | -- | 111 JD | 410 U | -- | 404 U | 368 U | -- | 638 U | -- |
| o-xylene | -- | -- | -- | 436 U | 529 U | 414 U | -- | -- | 544 D | -- | 462 U | 410 U | -- | 404 U | 368 U | -- | 638 U | -- |
| styrene | -- | -- | -- | 436 U | 529 U | 414 U | -- | -- | 369 U | -- | 462 U | 410 U | -- | 404 U | 368 U | -- | 638 U | -- |
| bromoform | -- | -- | -- | 436 U | 529 U | 414 U | -- | -- | 369 U | -- | 462 U | 410 U | -- | 404 U | 368 U | -- | 638 U | -- |
| isopropyl benzene (cumene) | -- | -- | -- | 436 U | 529 U | 414 U | -- | -- | 372 D | -- | 462 U | 244 JD | -- | 404 U | 368 U | -- | 638 U | -- |
| bromobenzene | -- | -- | -- | 436 U | 529 U | 414 U | -- | -- | 369 U | -- | 462 U | 410 U | -- | 404 U | 368 U | -- | 638 U | -- |
| 1,1,2,2-tetrachloroethane | -- | -- | -- | 436 U | 529 U | 414 U | -- | -- | 369 U | -- | 462 U | 410 U | -- | 245 JD | 368 U | -- | 638 U | -- |
| 1,2,3-trichloropropane | -- | -- | -- | 436 U | 529 U | 509 D | -- | -- | 1050 D | -- | 355 JD | 2660 D | -- | 126 JD | 368 U | -- | 638 U | -- |
| n-propyl benzene | -- | -- | -- | 436 U | 529 U | 145 JD | -- | -- | 645 D | -- | 462 U | 653 D | -- | 404 U | 368 U | -- | 638 U | -- |
| 2-chlorotoluene | -- | -- | -- | 436 U | 529 U | 414 U | -- | -- | 369 U | -- | 462 U | 410 U | -- | 404 U | 368 U | -- | 638 U | -- |
| 4-chlorotoluene | -- | -- | -- | 436 U | 529 U | 414 U | -- | -- | 369 U | -- | 462 U | 410 U | -- | 404 U | 368 U | -- | 638 U | -- |
| 1,3,5-trimethylbenzene | -- | -- | -- | 436 U | 529 U | 356 JD | -- | -- | 1700 D | -- | 233 JD | 117 JD | -- | 404 U | 368 U | -- | 638 U | -- |
| tert-butylbenzene | -- | -- | -- | 436 U | 529 U | 414 U | -- | -- | 369 U | -- | 462 U | 410 U | -- | 404 U | 368 U | -- | 638 U | -- |
| 1,2,4-trimethylbenzene | -- | -- | -- | 436 U | 529 U | 1170 D | -- | -- | 5710 D | -- | 751 D | 4060 D | -- | 150 JD | 84.7 JD | -- | 638 U | -- |
| sec-butylbenzene | -- | -- | -- | 436 U | 529 U | 139 JD | -- | -- | 537 D | -- | 462 U | 1020 D | -- | 404 U | 368 U | -- | 638 U | -- |
| 1,3-dichlorobenzene | -- | -- | -- | 436 U | 529 U | 226 JD | -- | -- | 1230 D | -- | 158 JD | 454 D | -- | 404 U | 368 U | -- | 638 U | -- |
| 4-isopropyltoluene | -- | -- | -- | 436 U | 529 U | 199 JD | -- | -- | 758 D | -- | 120 JD | 635 D | -- | 404 U | 368 U | -- | 638 U | -- |
| 1,4-dichlorobenzene | -- | -- | -- | 436 U | 129 JD | 1860 D | -- | -- | 9500 D | -- | 1260 D | 3030 D | -- | 190 JD | 130 JD | -- | 638 U | -- |
| 1,2-dichlorobenzene | -- | -- | -- | 436 U | 825 D | 14000 D | -- | -- | 105000 D | -- | 10500 D | 700 D | -- | 350 JD | 71.4 JD | -- | 218 JD | -- |
| n-butylbenzene | -- | -- | -- | 436 U | 529 U | 414 U | -- | -- | 369 U | -- | 462 U | 1498 D | -- | 86.4 JD | 368 U | -- | 638 U | -- |
| 1,2-dibromo-3-chloropropane | -- | -- | -- | 436 U | 529 U | 414 U | -- | -- | 369 U | -- | 462 U | 410 U | -- | 404 U | 368 U | -- | 638 U | -- |
| 1,2,4-trichlorobenzene | -- | -- | -- | 436 U | 529 U | 414 U | -- | -- | 399 D | -- | 462 U | 410 U | -- | 404 U | 368 U | -- | 638 U | -- |
| hexachlorobutadiene | -- | -- | -- | 436 U | 529 U | 414 U | -- | -- | 369 U | -- | 462 U | 410 U | -- | 404 U | 368 U | -- | 638 U | -- |
| naphthalene | -- | -- | -- | 436 U | 529 U | 624 D | -- | -- | 5000 D | -- | 1320 D | 332 JD | -- | 404 U | 368 U | -- | 638 U | -- |
| 1,2,3-trichlorobenzene | -- | -- | -- | 436 U | 529 U | 414 U | -- | -- | 369 U | -- | 462 U | 410 U | -- | 404 U | 368 U | -- | 638 U | -- |
| Methyl tertiary butyl ether | -- | -- | -- | 436 U | 529 U | 414 U | -- | -- | 369 U | -- | 462 U | 410 U | -- | 404 U | 368 U | -- | 638 U | -- |
| Acetone | -- | -- | -- | 871 U | 1057 U | 827 U | -- | -- | 738 U | -- | 923 U | 819 U | -- | 808 U | 736 U | -- | 596 JD | -- |
| carbon disulfide | -- | -- | -- | 436 U | 529 U | 414 U | -- | -- | 369 U | -- | 462 U | 410 U | -- | 404 U | 368 U | -- | 638 U | -- |
| 2-butanone (MEK) | -- | -- | -- | 842 JBD | 1023 BD | 639 JBD | -- | -- | 622 JBD | -- | 803 JBD | 1160 BD | -- | 1200 BD | 791 BD | -- | 2010 BD | -- |
| tetrahydrofuran (THF) | -- | -- | -- | 871 U | 1057 U | 827 U | -- | -- | 738 U | -- | 923 U | 819 U | -- | 808 U | 736 U | -- | 1276 U | -- |
| 4-methyl-2-pentanone (MIBK) | -- | -- | -- | 871 U | 1057 U | 827 U | -- | -- | 738 U | -- | 923 U | 819 U | -- | 808 U | 736 U | -- | 1276 U | -- |
| 2-hexanone | -- | -- | -- | 871 U | 1057 U | 827 U | -- | -- | 738 U | -- | 923 U | 819 U | -- | 808 U | 736 U | -- | 1276 U | -- |
| 2-chloroethyl vinyl ether | -- | -- | -- | 871 U | 1057 U | 827 U | -- | -- | 738 U | -- | 923 U | 819 U | -- | 808 U | 736 U | -- | 1276 U | -- |

Notes:

BOLD value indicates the compound was detected above the reporting limit.

U indicates the compound was not detected at the indicated concentration.

J indicates the presence of a compound that meets the identification criteria. The result is less than the quantitation limit but greater than zero, and is given an approximate value.

-- indicates analysis was not performed

D indicates the sample was diluted prior to analysis

B indicates the analyte was observed in the laboratory blank as well as the sample

APPENDIX C.1: SOIL ANALYTICAL DATA SUMMARY (VOCs)

| Sample ID | DPC-21-17.5 | DPC-21-18 | DPC-21-18.3 | DPC-21-18.5 | DPC-21-18.10 | DPC-21-19 | DPC-21-19.3 | DPC-21-19.6 | DPC-21-19.9 | DPC-21-20S | DPC-21-20D | DPC-21-22 | DPC-21-22.6 | DPC-22-17.4 | DPC-22-17.8 | DPC-22-17.9 | DPC-22-18.1 | DPC-22-18.9 | DPC-22-21 |
|-----------------------------|----------------|----------------|----------------|----------------|----------------|----------------|----------------|----------------|----------------|----------------|---------------|----------------|-------------|-------------|----------------|-------------|----------------|----------------|----------------|
| Sampling Date | 4/27/2015 | 4/27/2015 | 4/27/2015 | 4/27/2015 | 4/27/2015 | 4/27/2015 | 4/27/2015 | 4/27/2015 | 4/27/2015 | 4/27/2015 | 4/27/2015 | 4/27/2015 | 4/27/2015 | 4/27/2015 | 4/27/2015 | 4/27/2015 | 4/27/2015 | 4/27/2015 | 4/27/2015 |
| Vocals (GC/MS) | µg/kg | µg/kg | µg/kg | µg/kg | µg/kg | µg/kg | µg/kg | µg/kg | µg/kg | µg/kg | µg/kg | µg/kg | µg/kg | µg/kg | µg/kg | µg/kg | µg/kg | µg/kg | µg/kg |
| dichlorodifluoromethane | 531 U | 690 U | 697 U | 586 U | 917 U | 1035 U | 876 U | 859 U | 695 U | 728 U | 397 U | 373 U | -- | -- | 365 U | -- | 343 U | 513 U | 318 U |
| chloromethane | 531 U | 690 U | 697 U | 586 U | 917 U | 1035 U | 876 U | 859 U | 695 U | 728 U | 397 U | 373 U | -- | -- | 365 U | -- | 343 U | 513 U | 318 U |
| vinyl chloride | 1210 D | 2780 D | 2480 D | 2530 D | 3090 D | 3700 D | 5570 D | 5150 D | 3510 D | 2920 D | 397 U | 373 U | -- | -- | 1200 D | -- | 1230 D | 1570 D | 71.7 JD |
| bromomethane | 531 U | 690 U | 697 U | 586 U | 917 U | 1035 U | 876 U | 859 U | 695 U | 728 U | 397 U | 373 U | -- | -- | 365 U | -- | 343 U | 513 U | 318 U |
| chloroethane | 531 U | 690 U | 697 U | 586 U | 917 U | 1035 U | 876 U | 859 U | 695 U | 728 U | 397 U | 373 U | -- | -- | 365 U | -- | 343 U | 513 U | 318 U |
| trichlorofluoromethane | 531 U | 690 U | 697 U | 586 U | 917 U | 1035 U | 876 U | 859 U | 695 U | 728 U | 397 U | 373 U | -- | -- | 365 U | -- | 343 U | 513 U | 318 U |
| 1,1-dichloroethylene | 531 U | 690 U | 697 U | 586 U | 917 U | 1035 U | 876 U | 859 U | 695 U | 728 U | 397 U | 373 U | -- | -- | 365 U | -- | 343 U | 513 U | 318 U |
| methylene chloride | 531 U | 690 U | 697 U | 586 U | 917 U | 1035 U | 876 U | 859 U | 695 U | 728 U | 397 U | 373 U | -- | -- | 365 U | -- | 343 U | 513 U | 318 U |
| trans-1,2-dichloroethylene | 531 U | 690 U | 697 U | 586 U | 917 U | 1035 U | 876 U | 859 U | 695 U | 728 U | 397 U | 373 U | -- | -- | 365 U | -- | 343 U | 513 U | 318 U |
| 1,1-dichloroethane | 531 U | 690 U | 697 U | 586 U | 917 U | 1035 U | 876 U | 859 U | 695 U | 728 U | 397 U | 373 U | -- | -- | 365 U | -- | 343 U | 513 U | 318 U |
| 2,2-dichloropropane | 531 U | 690 U | 697 U | 586 U | 917 U | 1035 U | 876 U | 859 U | 695 U | 728 U | 397 U | 373 U | -- | -- | 365 U | -- | 343 U | 513 U | 318 U |
| cis 1,2- dichloroethylene | 5630 D | 17600 D | 20000 D | 22500 D | 28000 D | 31900 D | 39800 D | 65900 D | 52000 D | 43900 D | 395 JD | 149 JD | -- | -- | 13900 D | -- | 15000 D | 17200 D | 167 JD |
| bromochloromethane | 531 U | 690 U | 697 U | 586 U | 917 U | 1035 U | 876 U | 859 U | 695 U | 728 U | 397 U | 373 U | -- | -- | 365 U | -- | 343 U | 513 U | 318 U |
| chloroform | 531 U | 690 U | 697 U | 586 U | 213 JD | 1035 U | 215 JD | 216 JD | 160 JD | 728 U | 397 U | 74.7 JD | -- | -- | 71.5 JD | -- | 78.1 JD | 107 JD | 60.3 JD |
| 1,1,1-trichloroethane | 531 U | 690 U | 697 U | 586 U | 917 U | 1035 U | 876 U | 859 U | 695 U | 728 U | 397 U | 373 U | -- | -- | 365 U | -- | 343 U | 513 U | 318 U |
| carbon tetrachloride | 531 U | 690 U | 697 U | 586 U | 917 U | 1035 U | 876 U | 859 U | 695 U | 728 U | 397 U | 373 U | -- | -- | 365 U | -- | 343 U | 513 U | 318 U |
| 1,1-dichloropropene | 531 U | 690 U | 697 U | 586 U | 917 U | 1035 U | 876 U | 859 U | 695 U | 728 U | 397 U | 373 U | -- | -- | 365 U | -- | 343 U | 513 U | 318 U |
| benzene | 531 U | 690 U | 697 U | 586 U | 917 U | 1035 U | 876 U | 859 U | 695 U | 728 U | 397 U | 373 U | -- | -- | 365 U | -- | 343 U | 513 U | 318 U |
| 1,2-dichloroethane | 531 U | 690 U | 697 U | 586 U | 917 U | 1035 U | 876 U | 859 U | 695 U | 728 U | 397 U | 373 U | -- | -- | 365 U | -- | 343 U | 513 U | 318 U |
| trichloroethylene | 133 JD | 690 U | 697 U | 180 JD | 917 U | 1035 U | 159 JD | 148 JD | 517 JD | 891 D | 397 U | 373 U | -- | -- | 14300 D | -- | 17900 D | 18300 D | 215 JD |
| 1,2-dichloropropane | 531 U | 690 U | 697 U | 586 U | 917 U | 1035 U | 876 U | 859 U | 695 U | 728 U | 397 U | 373 U | -- | -- | 365 U | -- | 343 U | 513 U | 318 U |
| dibromomethane | 531 U | 690 U | 697 U | 586 U | 917 U | 1035 U | 876 U | 859 U | 695 U | 728 U | 397 U | 373 U | -- | -- | 365 U | -- | 343 U | 513 U | 318 U |
| bromodichloromethane | 531 U | 690 U | 697 U | 586 U | 917 U | 1035 U | 876 U | 859 U | 695 U | 728 U | 397 U | 373 U | -- | -- | 365 U | -- | 343 U | 513 U | 318 U |
| cis-1,3-dichloropropene | 531 U | 690 U | 697 U | 586 U | 917 U | 1035 U | 876 U | 859 U | 695 U | 728 U | 397 U | 373 U | -- | -- | 365 U | -- | 343 U | 513 U | 318 U |
| toluene | 531 U | 690 U | 697 U | 586 U | 917 U | 1035 U | 876 U | 859 U | 695 U | 728 U | 397 U | 373 U | -- | -- | 365 U | -- | 343 U | 513 U | 318 U |
| trans-1,3-dichloropropene | 531 U | 690 U | 697 U | 586 U | 917 U | 1035 U | 876 U | 859 U | 695 U | 728 U | 397 U | 373 U | -- | -- | 365 U | -- | 343 U | 513 U | 318 U |
| 1,1,2-trichloroethane | 531 U | 690 U | 697 U | 586 U | 917 U | 1035 U | 876 U | 859 U | 695 U | 728 U | 397 U | 373 U | -- | -- | 365 U | -- | 343 U | 513 U | 318 U |
| tetrachloroethylene | 531 U | 690 U | 697 U | 586 U | 917 U | 1035 U | 876 U | 859 U | 695 U | 728 U | 397 U | 373 U | -- | -- | 365 U | -- | 343 U | 513 U | 318 U |
| 1,3-dichloropropane | 531 U | 690 U | 697 U | 586 U | 917 U | 1035 U | 876 U | 859 U | 695 U | 728 U | 397 U | 373 U | -- | -- | 365 U | -- | 343 U | 513 U | 318 U |
| dibromochloromethane | 531 U | 690 U | 697 U | 586 U | 917 U | 1035 U | 876 U | 859 U | 695 U | 728 U | 397 U | 373 U | -- | -- | 365 U | -- | 343 U | 513 U | 318 U |
| 1,2-dibromoethane | 531 U | 690 U | 697 U | 586 U | 917 U | 1035 U | 876 U | 859 U | 695 U | 728 U | 397 U | 373 U | -- | -- | 365 U | -- | 343 U | 513 U | 318 U |
| chlorobenzene | 259 JD | 532 JD | 131 JD | 111 JD | 917 U | 1035 U | 876 U | 859 U | 695 U | 728 U | 397 U | 373 U | -- | -- | 60.0 JD | -- | 58.7 JD | 79.8 JD | 318 U |
| 1,1,1,2-tetrachloroethane | 531 U | 690 U | 697 U | 586 U | 917 U | 1035 U | 876 U | 859 U | 695 U | 728 U | 397 U | 373 U | -- | -- | 365 U | -- | 343 U | 513 U | 318 U |
| ethylbenzene | 531 U | 690 U | 697 U | 586 U | 917 U | 1035 U | 876 U | 859 U | 695 U | 728 U | 397 U | 373 U | -- | -- | 365 U | -- | 343 U | 513 U | 318 U |
| xylenes (m/p) | 531 U | 690 U | 697 U | 586 U | 917 U | 1035 U | 876 U | 859 U | 695 U | 728 U | 397 U | 373 U | -- | -- | 365 U | -- | 343 U | 513 U | 318 U |
| o-xylene | 531 U | 690 U | 697 U | 586 U | 917 U | 1035 U | 876 U | 859 U | 695 U | 728 U | 397 U | 373 U | -- | -- | 365 U | -- | 343 U | 513 U | 318 U |
| styrene | 531 U | 690 U | 697 U | 586 U | 917 U | 1035 U | 876 U | 859 U | 695 U | 728 U | 397 U | 373 U | -- | -- | 365 U | -- | 343 U | 513 U | 318 U |
| bromoform | 531 U | 690 U | 697 U | 586 U | 917 U | 1035 U | 876 U | 859 U | 695 U | 728 U | 397 U | 373 U | -- | -- | 365 U | -- | 343 U | 513 U | 318 U |
| isopropyl benzene (cumene) | 531 U | 690 U | 697 U | 586 U | 917 U | 1035 U | 876 U | 859 U | 695 U | 728 U | 397 U | 373 U | -- | -- | 365 U | -- | 343 U | 513 U | 318 U |
| bromobenzene | 531 U | 690 U | 697 U | 586 U | 917 U | 1035 U | 876 U | 859 U | 695 U | 728 U | 397 U | 373 U | -- | -- | 365 U | -- | 343 U | 513 U | 318 U |
| 1,1,2,2-tetrachloroethane | 531 U | 690 U | 697 U | 586 U | 917 U | 1035 U | 876 U | 859 U | 695 U | 728 U | 397 U | 373 U | -- | -- | 365 U | -- | 343 U | 513 U | 318 U |
| 1,2,3-trichloropropane | 531 U | 675 JD | 697 U | 586 U | 917 U | 1035 U | 876 U | 859 U | 695 U | 728 U | 397 U | 373 U | -- | -- | 365 U | -- | 343 U | 513 U | 318 U |
| n-propyl benzene | 531 U | 690 U | 697 U | 586 U | 917 U | 1035 U | 876 U | 859 U | 695 U | 728 U | 397 U | 373 U | -- | -- | 365 U | -- | 343 U | 513 U | 318 U |
| 2-chlorotoluene | 531 U | 690 U | 697 U | 586 U | 917 U | 1035 U | 876 U | 859 U | 695 U | 728 U | 397 U | 373 U | -- | -- | 365 U | -- | 343 U | 513 U | 318 U |
| 4-chlorotoluene | 531 U | 690 U | 697 U | 586 U | 917 U | 1035 U | 876 U | 859 U | 695 U | 728 U | 397 U | 373 U | -- | -- | 365 U | -- | 343 U | 513 U | 318 U |
| 1,3,5-trimethylbenzene | 531 U | 690 U | 697 U | 586 U | 917 U | 1035 U | 876 U | 859 U | 695 U | 728 U | 397 U | 373 U | -- | -- | 365 U | -- | 343 U | 513 U | 318 U |
| tert-butylbenzene | 531 U | 690 U | 697 U | 586 U | 917 U | 1035 U | 876 U | 859 U | 695 U | 728 U | 397 U | 373 U | -- | -- | 365 U | -- | 343 U | 513 U | 318 U |
| 1,2,4-trimethylbenzene | 531 U | 345 JD | 697 U | 586 U | 917 U | 1035 U | 876 U | 373 JD | 695 U | 728 U | 397 U | 373 U | -- | -- | 365 U | -- | 343 U | 513 U | 318 U |
| sec-butylbenzene | 531 U | 690 U | 697 U | 586 U | 917 U | 1035 U | 876 U | 859 U | 695 U | 728 U | 397 U | 373 U | -- | -- | 365 U | -- | 343 U | 513 U | 318 U |
| 1,3-dichlorobenzene | 531 U | 189 JD | 697 U | 586 U | 917 U | 1035 U | 876 U | 859 U | 695 U | 728 U | 397 U | 373 U | -- | -- | 365 U | -- | 343 U | 513 U | 318 U |
| 4-isopropyltoluene | 531 U | 690 U | 697 U | 586 U | 917 U | 1035 U | 876 U | 859 U | 695 U | 728 U | 397 U | 373 U | -- | -- | 365 U | -- | 343 U | 513 U | 318 U |
| 1,4-dichlorobenzene | 187 JD | 1210 D | 160 JD | 130 JD | 917 U | 1035 U | 876 U | 530 JD | 695 U | 728 U | 397 U | 373 U | -- | -- | 72.2 JD | -- | 71.3 JD | 513 U | 318 U |
| 1,2-dichlorobenzene | 797 D | 8990 D | 1010 D | 790 D | 390 JD | 396 JD | 755 JD | 4050 D | 1270 D | 780 D | 397 U | 373 U | -- | -- | 542 D | -- | 568 D | 579 D | 318 U |
| n-butylbenzene | 531 U | 690 U | 697 U | 586 U | 917 U | 1035 U | 876 U | 859 U | 695 U | 728 U | 397 U | 373 U | -- | -- | 365 U | -- | 343 U | 513 U | 318 U |
| 1,2-dibromo-3-chloropropane | 531 U | 690 U | 697 U | 586 U | 917 U | 1035 U | 876 U | 859 U | 695 U | 728 U | 397 U | 373 U | -- | -- | 365 U | -- | 343 U | 513 U | 318 U |
| 1,2,4-trichlorobenzene | 531 U | 690 U | 697 U | 586 U | 917 U | 1035 U | 876 U | 859 U | 695 U | 728 U | 397 U | 373 U | -- | -- | 365 U | -- | 343 U | 513 U | 318 U |
| hexachlorobutadiene | 531 U | 690 U | 697 U | 586 U | 917 U | 1035 U | 876 U | 859 U | 695 U | 728 U | 397 U | 373 U | -- | -- | 365 U | -- | 343 U | 513 U | 318 U |
| naphthalene | 531 U | 690 U | 697 U | 586 U | 917 U | 1035 U | 876 U | 859 U | 695 U | 728 U | 397 U | 373 U | -- | -- | 365 U | -- | 343 U | 513 U | 318 U |
| 1,2,3-trichlorobenzene | 251 JD | 690 U | 697 U | 586 U | 917 U | 1035 U | 876 U | 859 U | 695 U | 728 U | 397 U | 373 U | -- | -- | 365 U | -- | 343 U | 513 U | 318 U |
| Methyl tertiary butyl ether | 531 U | 690 U | 697 U | 586 U | 917 U | 1035 U | 876 U | 859 U | 695 U | 728 U | 397 U | 373 U | -- | -- | 365 U | -- | 343 U | 513 U | 318 U |
| Acetone | 546 JD | 1379 U | 1394 U | 1172 U | 1834 U | 2071 U | 1751 U | 1718 U | 1389 U | 1456 U | 793 U | 747 U | -- | -- | 729 U | -- | 685 U | 1026 U | 635 U |
| carbon disulfide | 531 U | 690 U | 697 U | 586 U | 917 U | 1035 U | 876 U | 859 U | 695 U | 728 U | 397 U | 373 U | -- | -- | 365 U | -- | 343 U | 513 U | 318 U |
| 2-butanone (MEK) | 1740 BD | 2680 BD | 2 | | | | | | | | | | | | | | | | |

APPENDIX C.1: SOIL ANALYTICAL DATA SUMMARY (VOCs)

| Sample ID | DPC-23-17.5 | DPC-23-18 | DPC-23-19 | DPC-23-19.4 | DPC-23-19.6 | DPC-23-21 | DPC-23-21.2 | DPC-24-17.3 | DPC-24-17.6 | DPC-24-18 | DPC-24-21.3 | DPC-24-21.6 | DPC-24-21.9 | DPC-24-22 |
|-----------------------------|-------------|----------------|----------------|-------------|----------------|----------------|-------------|-------------|-------------|----------------|-------------|-------------|-------------|----------------|
| Sampling Date | 4/27/2015 | 4/27/2015 | 4/27/2015 | 4/27/2015 | 4/27/2015 | 4/27/2015 | 4/27/2015 | 4/28/2015 | 4/27/2015 | 4/28/2015 | 4/28/2015 | 4/28/2015 | 4/28/2015 | 4/28/2015 |
| VOCS (GC/MS) | µg/kg | µg/kg | µg/kg | µg/kg | µg/kg | µg/kg | µg/kg | µg/kg | µg/kg | µg/kg | µg/kg | µg/kg | µg/kg | µg/kg |
| dichlorodifluoromethane | -- | 483 U | 695 U | -- | 439 U | 332 U | -- | -- | -- | 413 U | -- | -- | -- | 280 U |
| chloromethane | -- | 483 U | 695 U | -- | 439 U | 332 U | -- | -- | -- | 413 U | -- | -- | -- | 280 U |
| vinyl chloride | -- | 1280 D | 1610 D | -- | 1140 D | 332 U | -- | -- | -- | 95.9 JD | -- | -- | -- | 280 U |
| bromomethane | -- | 483 U | 695 U | -- | 439 U | 332 U | -- | -- | -- | 413 U | -- | -- | -- | 280 U |
| chloroethane | -- | 483 U | 695 U | -- | 439 U | 332 U | -- | -- | -- | 413 U | -- | -- | -- | 280 U |
| trichlorofluoromethane | -- | 483 U | 695 U | -- | 439 U | 332 U | -- | -- | -- | 413 U | -- | -- | -- | 280 U |
| 1,1-dichloroethylene | -- | 483 U | 695 U | -- | 439 U | 332 U | -- | -- | -- | 413 U | -- | -- | -- | 280 U |
| methylene chloride | -- | 483 U | 695 U | -- | 439 U | 332 U | -- | -- | -- | 413 U | -- | -- | -- | 280 U |
| trans-1,2-dichloroethylene | -- | 483 U | 695 U | -- | 439 U | 332 U | -- | -- | -- | 413 U | -- | -- | -- | 280 U |
| 1,1-dichloroethane | -- | 483 U | 695 U | -- | 439 U | 332 U | -- | -- | -- | 413 U | -- | -- | -- | 280 U |
| 2,2-dichloropropane | -- | 483 U | 695 U | -- | 439 U | 332 U | -- | -- | -- | 413 U | -- | -- | -- | 280 U |
| cis 1,2- dichloroethylene | -- | 13900 D | 12900 D | -- | 8940 D | 230 JD | -- | -- | -- | 1290 D | -- | -- | -- | 280 U |
| bromochloromethane | -- | 483 U | 695 U | -- | 439 U | 332 U | -- | -- | -- | 413 U | -- | -- | -- | 280 U |
| chloroform | -- | 97.5 JD | 151 JD | -- | 95.6 JD | 65.0 JD | -- | -- | -- | 98.4 JD | -- | -- | -- | 49.3 JD |
| 1,1,1-trichloroethane | -- | 483 U | 695 U | -- | 439 U | 332 U | -- | -- | -- | 413 U | -- | -- | -- | 280 U |
| carbon tetrachloride | -- | 483 U | 695 U | -- | 439 U | 332 U | -- | -- | -- | 413 U | -- | -- | -- | 280 U |
| 1,1-dichloropropene | -- | 483 U | 695 U | -- | 439 U | 332 U | -- | -- | -- | 413 U | -- | -- | -- | 280 U |
| benzene | -- | 483 U | 695 U | -- | 439 U | 332 U | -- | -- | -- | 413 U | -- | -- | -- | 280 U |
| 1,2-dichloroethane | -- | 483 U | 695 U | -- | 439 U | 332 U | -- | -- | -- | 413 U | -- | -- | -- | 280 U |
| trichloroethylene | -- | 1170 D | 979 D | -- | 463 D | 189 JD | -- | -- | -- | 9070 D | -- | -- | -- | 170 JD |
| 1,2-dichloropropane | -- | 483 U | 695 U | -- | 439 U | 332 U | -- | -- | -- | 413 U | -- | -- | -- | 280 U |
| dibromomethane | -- | 483 U | 695 U | -- | 439 U | 332 U | -- | -- | -- | 413 U | -- | -- | -- | 280 U |
| bromodichloromethane | -- | 483 U | 695 U | -- | 439 U | 332 U | -- | -- | -- | 413 U | -- | -- | -- | 280 U |
| cis-1,3-dichloropropene | -- | 483 U | 695 U | -- | 439 U | 332 U | -- | -- | -- | 413 U | -- | -- | -- | 280 U |
| toluene | -- | 483 U | 695 U | -- | 439 U | 332 U | -- | -- | -- | 413 U | -- | -- | -- | 280 U |
| trans-1,3-dichloropropene | -- | 483 U | 695 U | -- | 439 U | 332 U | -- | -- | -- | 413 U | -- | -- | -- | 280 U |
| 1,1,2-trichloroethane | -- | 483 U | 695 U | -- | 439 U | 332 U | -- | -- | -- | 413 U | -- | -- | -- | 280 U |
| tetrachloroethylene | -- | 483 U | 695 U | -- | 439 U | 332 U | -- | -- | -- | 413 U | -- | -- | -- | 280 U |
| 1,3-dichloropropane | -- | 483 U | 695 U | -- | 439 U | 332 U | -- | -- | -- | 413 U | -- | -- | -- | 280 U |
| dibromochloromethane | -- | 483 U | 695 U | -- | 439 U | 332 U | -- | -- | -- | 413 U | -- | -- | -- | 280 U |
| 1,2-dibromoethane | -- | 483 U | 695 U | -- | 439 U | 332 U | -- | -- | -- | 413 U | -- | -- | -- | 280 U |
| chlorobenzene | -- | 483 U | 695 U | -- | 439 U | 332 U | -- | -- | -- | 413 U | -- | -- | -- | 280 U |
| 1,1,1,2-tetrachloroethane | -- | 483 U | 695 U | -- | 439 U | 332 U | -- | -- | -- | 413 U | -- | -- | -- | 280 U |
| ethylbenzene | -- | 483 U | 695 U | -- | 439 U | 332 U | -- | -- | -- | 413 U | -- | -- | -- | 280 U |
| xylenes (m/p) | -- | 483 U | 695 U | -- | 439 U | 332 U | -- | -- | -- | 413 U | -- | -- | -- | 280 U |
| o-xylene | -- | 483 U | 695 U | -- | 439 U | 332 U | -- | -- | -- | 413 U | -- | -- | -- | 280 U |
| styrene | -- | 483 U | 695 U | -- | 439 U | 332 U | -- | -- | -- | 413 U | -- | -- | -- | 280 U |
| bromoform | -- | 483 U | 695 U | -- | 439 U | 332 U | -- | -- | -- | 413 U | -- | -- | -- | 280 U |
| isopropyl benzene (cumene) | -- | 483 U | 695 U | -- | 439 U | 332 U | -- | -- | -- | 413 U | -- | -- | -- | 280 U |
| bromobenzene | -- | 483 U | 695 U | -- | 439 U | 332 U | -- | -- | -- | 413 U | -- | -- | -- | 280 U |
| 1,1,2,2-tetrachloroethane | -- | 483 U | 695 U | -- | 439 U | 332 U | -- | -- | -- | 413 U | -- | -- | -- | 280 U |
| 1,2,3-trichloropropane | -- | 483 U | 695 U | -- | 439 U | 332 U | -- | -- | -- | 413 U | -- | -- | -- | 280 U |
| n-propyl benzene | -- | 483 U | 695 U | -- | 439 U | 332 U | -- | -- | -- | 413 U | -- | -- | -- | 280 U |
| 2-chlorotoluene | -- | 483 U | 695 U | -- | 439 U | 332 U | -- | -- | -- | 413 U | -- | -- | -- | 280 U |
| 4-chlorotoluene | -- | 483 U | 695 U | -- | 439 U | 332 U | -- | -- | -- | 413 U | -- | -- | -- | 280 U |
| 1,3,5-trimethylbenzene | -- | 483 U | 695 U | -- | 439 U | 332 U | -- | -- | -- | 413 U | -- | -- | -- | 280 U |
| tert-butylbenzene | -- | 483 U | 695 U | -- | 439 U | 332 U | -- | -- | -- | 413 U | -- | -- | -- | 280 U |
| 1,2,4-trimethylbenzene | -- | 483 U | 695 U | -- | 439 U | 332 U | -- | -- | -- | 413 U | -- | -- | -- | 280 U |
| sec-butylbenzene | -- | 483 U | 695 U | -- | 439 U | 332 U | -- | -- | -- | 413 U | -- | -- | -- | 280 U |
| 1,3-dichlorobenzene | -- | 483 U | 695 U | -- | 439 U | 332 U | -- | -- | -- | 413 U | -- | -- | -- | 280 U |
| 4-isopropyltoluene | -- | 483 U | 695 U | -- | 439 U | 332 U | -- | -- | -- | 413 U | -- | -- | -- | 280 U |
| 1,4-dichlorobenzene | -- | 483 U | 695 U | -- | 439 U | 332 U | -- | -- | -- | 413 U | -- | -- | -- | 280 U |
| 1,2-dichlorobenzene | -- | 393 JD | 456 JD | -- | 335 JD | 332 U | -- | -- | -- | 171 JD | -- | -- | -- | 280 U |
| n-butylbenzene | -- | 483 U | 695 U | -- | 439 U | 332 U | -- | -- | -- | 413 U | -- | -- | -- | 280 U |
| 1,2-dibromo-3-chloropropane | -- | 483 U | 695 U | -- | 439 U | 332 U | -- | -- | -- | 413 U | -- | -- | -- | 280 U |
| 1,2,4-trichlorobenzene | -- | 483 U | 695 U | -- | 439 U | 332 U | -- | -- | -- | 413 U | -- | -- | -- | 280 U |
| hexachlorobutadiene | -- | 483 U | 695 U | -- | 439 U | 332 U | -- | -- | -- | 413 U | -- | -- | -- | 280 U |
| naphthalene | -- | 483 U | 695 U | -- | 439 U | 332 U | -- | -- | -- | 413 U | -- | -- | -- | 280 U |
| 1,2,3-trichlorobenzene | -- | 483 U | 695 U | -- | 439 U | 332 U | -- | -- | -- | 413 U | -- | -- | -- | 280 U |
| Methyl tertiary butyl ether | -- | 483 U | 695 U | -- | 439 U | 332 U | -- | -- | -- | 413 U | -- | -- | -- | 280 U |
| Acetone | -- | 965 U | 1389 U | -- | 877 U | 663 U | -- | -- | -- | 827 U | -- | -- | -- | 561 U |
| carbon disulfide | -- | 483 U | 695 U | -- | 439 U | 332 U | -- | -- | -- | 413 U | -- | -- | -- | 280 U |
| 2-butanone (MEK) | -- | 895 BD | 1453 BD | -- | 837 JBD | 663 JBD | -- | -- | -- | 1390 BD | -- | -- | -- | 630 BD |
| tetrahydrofuran (THF) | -- | 965 U | 1389 U | -- | 877 U | 663 U | -- | -- | -- | 827 U | -- | -- | -- | 561 U |
| 4-methyl-2-pentanone (MIBK) | -- | 965 U | 1389 U | -- | 877 U | 663 U | -- | -- | -- | 827 U | -- | -- | -- | 561 U |
| 2-hexanone | -- | 965 U | 1389 U | -- | 877 U | 663 U | -- | -- | -- | 827 U | -- | -- | -- | 561 U |
| 2-chloroethyl vinyl ether | -- | 965 U | 1389 U | -- | 877 U | 663 U | -- | -- | -- | 827 U | -- | -- | -- | 561 U |

Notes:

BOLD value indicates the compound was detected above the reporting limit.

U indicates the compound was not detected at the indicated concentration.

J indicates the presence of a compound that meets the identification criteria. The result is less than the quantitation limit but greater than zero, and is given an approximate value.

-- indicates analysis was not performed

D indicates the sample was diluted prior to analysis

B indicates the analyte was observed in the laboratory blank as well as the sample

APPENDIX C.2: SOIL ANALYTICAL DATA SUMMARY (TOC, MICROBIAL COMMUNITY AND CSIA)

| Sample ID | DPC-19-17.3 | DPC-19-17.6 | DPC-19-17.8 | DPC-19-18 | DPC-20-19 | DPC-20-19.3 | DPC-20-19.4 | DPC-20-19.5 | DPC-20-19.6 | DPC-20-19.7 | DPC-20-20 | DPC-20-20.6 | DPC-20-20.11 | DPC-20-21 |
|--|-----------------------|-----------------------|-----------------------|-----------------------|-----------------------|-----------------------|-----------------------|-----------------------|-----------------------|-----------------------|-----------------------|-----------------------|-----------------------|-----------------------|
| Sampling Date | 4/28/2015 | 4/28/2015 | 4/28/2015 | 4/28/2015 | 4/27/2015 | 4/27/2015 | 4/27/2015 | 4/27/2015 | 4/27/2015 | 4/27/2015 | 4/27/2015 | 4/27/2015 | 4/27/2015 | 4/27/2015 |
| SOIL CHEMISTRY | mg/kg | mg/kg | mg/kg | mg/kg | mg/kg | mg/kg | mg/kg | mg/kg | mg/kg | mg/kg | mg/kg | mg/kg | mg/kg | mg/kg |
| Total Organic Carbon (TOC) value | 109 | -- | -- | -- | -- | -- | 312 | -- | -- | -- | -- | -- | 145 | -- |
| Std Dev | 51.5 | -- | -- | -- | -- | -- | 114 | -- | -- | -- | -- | -- | 49.0 | -- |
| MICROBIAL COMMUNITY | cells/g | cells/g | cells/g | cells/g | cells/g | cells/g | cells/g | cells/g | cells/g | cells/g | cells/g | cells/g | cells/g | cells/g |
| Reductive Dechlorination | | | | | | | | | | | | | | |
| <i>Dehalococcoides</i> spp. DHC | -- | -- | 1.00E+03 U | -- | -- | -- | -- | 2.48E+05 | -- | -- | -- | -- | -- | -- |
| tceA Reductase TCE | -- | -- | 1.00E+03 U | -- | -- | -- | -- | 4.51E+04 | -- | -- | -- | -- | -- | -- |
| BAV1 Vinyl Chloride Reductase BVC | -- | -- | 1.00E+03 U | -- | -- | -- | -- | 4.55E+03 | -- | -- | -- | -- | -- | -- |
| Vinyl Chloride Reductase VCR | -- | -- | 1.00E+03 U | -- | -- | -- | -- | 2.38E+03 | -- | -- | -- | -- | -- | -- |
| <i>Dehalobacter</i> spp. DHBt | -- | -- | 1.00E+04 U | -- | -- | -- | -- | 6.95E+04 | -- | -- | -- | -- | -- | -- |
| <i>Dehalobacter</i> DCM | -- | -- | 1.00E+04 U | -- | -- | -- | -- | 1.00E+04 U | -- | -- | -- | -- | -- | -- |
| <i>Dehalogenimonas</i> spp. DHG | -- | -- | 1.00E+04 U | -- | -- | -- | -- | 7.18E+04 | -- | -- | -- | -- | -- | -- |
| <i>Desulfitobacterium</i> spp. DSB | -- | -- | 1.00E+04 U | -- | -- | -- | -- | 5.62E+03 J | -- | -- | -- | -- | -- | -- |
| <i>Dehalobium chlorocoercia</i> DECO | -- | -- | 1.00E+04 U | -- | -- | -- | -- | 1.00E+04 U | -- | -- | -- | -- | -- | -- |
| <i>Desulfuromonas</i> spp. DSM | -- | -- | 1.00E+04 U | -- | -- | -- | -- | 1.00E+04 U | -- | -- | -- | -- | -- | -- |
| Chloroform reductase CFR | -- | -- | 1.00E+04 U | -- | -- | -- | -- | 1.00E+04 U | -- | -- | -- | -- | -- | -- |
| 1,1-DCA Reductase DCA | -- | -- | 1.00E+04 U | -- | -- | -- | -- | 1.00E+04 U | -- | -- | -- | -- | -- | -- |
| 1,2-DCA Reductase DCAR | -- | -- | 1.00E+04 U | -- | -- | -- | -- | 1.00E+04 U | -- | -- | -- | -- | -- | -- |
| Aerobic Cometabolic | | | | | | | | | | | | | | |
| Soluble Methane Monooxygenase SMMO | -- | -- | 5.20E+03 J | -- | -- | -- | -- | 1.00E+04 | -- | -- | -- | -- | -- | -- |
| Particulate Methane Monooxygenase PMMO | -- | -- | 3.31E+03 J | -- | -- | -- | -- | 6.18E+04 | -- | -- | -- | -- | -- | -- |
| Toluene Dioxygenase TOD | -- | -- | 1.31E+04 | -- | -- | -- | -- | 1.00E+04 U | -- | -- | -- | -- | -- | -- |
| Phenol Hydroxylase PHE | -- | -- | 1.00E+04 U | -- | -- | -- | -- | 1.00E+04 U | -- | -- | -- | -- | -- | -- |
| Trichlorobenzene Dioxygenase TCBO | -- | -- | 1.00E+04 U | -- | -- | -- | -- | 1.00E+04 U | -- | -- | -- | -- | -- | -- |
| Toluene Monooxygenase 2 RDEG | -- | -- | 1.00E+04 U | -- | -- | -- | -- | 1.00E+04 U | -- | -- | -- | -- | -- | -- |
| Toluene Monooxygenase RMO | -- | -- | 1.00E+04 U | -- | -- | -- | -- | 1.00E+04 U | -- | -- | -- | -- | -- | -- |
| Ethene Monooxygenase EtnC | -- | -- | 1.00E+04 U | -- | -- | -- | -- | 1.00E+04 U | -- | -- | -- | -- | -- | -- |
| Epoxyalkane transferase EtnE | -- | -- | 1.00E+04 U | -- | -- | -- | -- | 1.00E+04 U | -- | -- | -- | -- | -- | -- |
| Dichloromethane dehalogenase DCMA | -- | -- | 1.00E+04 U | -- | -- | -- | -- | 1.00E+04 U | -- | -- | -- | -- | -- | -- |
| Other | | | | | | | | | | | | | | |
| Total Eubacteria EBAC | -- | -- | 1.46E+07 | -- | -- | -- | -- | 1.85E+07 | -- | -- | -- | -- | -- | -- |
| Sulfate Reducing Bacteria APS | -- | -- | 1.00E+04 U | -- | -- | -- | -- | 1.17E+06 | -- | -- | -- | -- | -- | -- |
| Methanogens MGN | -- | -- | 1.00E+04 U | -- | -- | -- | -- | 1.00E+04 U | -- | -- | -- | -- | -- | -- |
| CSIA | $\delta^{13}\text{C}$ | $\delta^{13}\text{C}$ | $\delta^{13}\text{C}$ | $\delta^{13}\text{C}$ | $\delta^{13}\text{C}$ | $\delta^{13}\text{C}$ | $\delta^{13}\text{C}$ | $\delta^{13}\text{C}$ | $\delta^{13}\text{C}$ | $\delta^{13}\text{C}$ | $\delta^{13}\text{C}$ | $\delta^{13}\text{C}$ | $\delta^{13}\text{C}$ | $\delta^{13}\text{C}$ |
| cis-1,2-dichloroethene | -- | U* | -- | -- | -- | -- | -- | -- | -- | -24.48 | -- | -- | -- | -- |
| Trichloroethene | -- | -25.73 | -- | -- | -- | -- | -- | -- | -- | -24.83 | -- | -- | -- | -- |

Notes:

BOLD value indicates the compound was detected above the reporting limit.

U indicates the compound was not detected at the indicated concentration.

J indicates the presence of a compound that meets the identification criteria. The result is less than the quantitation limit but greater than zero, and is given an approximate value.

-- indicates analysis was not performed

U* (CSIA): Either there was no peak corresponding to the target analyte or that such a peak did not produce a reliable CSIA result.

APPENDIX C.2: SOIL ANALYTICAL DATA SUMMARY (TOC, MICROBIAL COMMUNITY AND CSIA)

| Sample ID | | DPC-20-21.6 | DPC-20-22.2 | DPC-21-17 | DPC-21-17.3 | DPC-21-17.5 | DPC-21-18 | DPC-21-18.3 | DPC-21-18.5 | DPC-21-18.10 | DPC-21-19 | DPC-21-19.3 | DPC-21-19.6 | DPC-21-19.9 | DPC-21-20S |
|-----------------------------------|---------|----------------|-------------------|----------------|----------------|----------------|----------------|-----------------|----------------|----------------|----------------|----------------|----------------|----------------|----------------|
| Sampling Date | | 4/27/2015 | 4/27/2015 | 4/27/2015 | 4/27/2015 | 4/27/2015 | 4/27/2015 | 4/27/2015 | 4/27/2015 | 4/27/2015 | 4/27/2015 | 4/27/2015 | 4/27/2015 | 4/27/2015 | 4/27/2015 |
| SOIL CHEMISTRY | | mg/kg | mg/kg | mg/kg | mg/kg | mg/kg | mg/kg | mg/kg | mg/kg | mg/kg | mg/kg | mg/kg | mg/kg | mg/kg | mg/kg |
| Total Organic Carbon (TOC) | value | -- | -- | -- | 182 | -- | -- | -- | -- | -- | -- | -- | -- | -- | -- |
| | Std Dev | -- | -- | -- | 64 | -- | -- | -- | -- | -- | -- | -- | -- | -- | -- |
| MICROBIAL COMMUNITY | | cells/g | cells/g | cells/g | cells/g | cells/g | cells/g | cells/g | cells/g | cells/g | cells/g | cells/g | cells/g | cells/g | cells/g |
| Reductive Dechlorination | | | | | | | | | | | | | | | |
| <i>Dehalococcoides</i> spp. | DHC | -- | 1.00E+03 U | -- | -- | -- | -- | 1.00E+03 U | -- | -- | -- | -- | -- | -- | -- |
| tceA Reductase | TCE | -- | 1.00E+03 U | -- | -- | -- | -- | 1.00E+03 U | -- | -- | -- | -- | -- | -- | -- |
| BAV1 Vinyl Chloride Reductase | BVC | -- | 1.00E+03 U | -- | -- | -- | -- | 1.00E+03 U | -- | -- | -- | -- | -- | -- | -- |
| Vinyl Chloride Reductase | VCR | -- | 1.00E+03 U | -- | -- | -- | -- | 1.00E+03 U | -- | -- | -- | -- | -- | -- | -- |
| <i>Dehalobacter</i> spp. | DHBt | -- | 1.00E+04 U | -- | -- | -- | -- | 1.00E+04 U | -- | -- | -- | -- | -- | -- | -- |
| <i>Dehalobacter</i> DCM | DCM | -- | 1.00E+04 U | -- | -- | -- | -- | 1.00E+04 U | -- | -- | -- | -- | -- | -- | -- |
| <i>Dehalogenimonas</i> spp. | DHG | -- | 1.00E+04 U | -- | -- | -- | -- | 1.00E+04 U | -- | -- | -- | -- | -- | -- | -- |
| <i>Desulfitobacterium</i> spp. | DSB | -- | 1.00E+04 U | -- | -- | -- | -- | 1.00E+04 U | -- | -- | -- | -- | -- | -- | -- |
| <i>Dehalobium chlorocoercia</i> | DECO | -- | 1.00E+04 U | -- | -- | -- | -- | 1.00E+04 U | -- | -- | -- | -- | -- | -- | -- |
| <i>Desulfuromonas</i> spp. | DSM | -- | 7.85E+03 J | -- | -- | -- | -- | 1.00E+04 U | -- | -- | -- | -- | -- | -- | -- |
| Chloroform reductase | CFR | -- | 1.00E+04 U | -- | -- | -- | -- | 1.00E+04 U | -- | -- | -- | -- | -- | -- | -- |
| 1,1-DCA Reductase | DCA | -- | 1.00E+04 U | -- | -- | -- | -- | 1.00E+04 U | -- | -- | -- | -- | -- | -- | -- |
| 1,2-DCA Reductase | DCAR | -- | 1.00E+04 U | -- | -- | -- | -- | 1.00E+04 U | -- | -- | -- | -- | -- | -- | -- |
| Aerobic Cometabolic | | | | | | | | | | | | | | | |
| Soluble Methane Monooxygenase | SMMO | -- | 1.00E+04 U | -- | -- | -- | -- | 5.06E+04 | -- | -- | -- | -- | -- | -- | -- |
| Particulate Methane Monooxygenase | PMMO | -- | 4.31E+03 J | -- | -- | -- | -- | 6.38E+06 | -- | -- | -- | -- | -- | -- | -- |
| Toluene Dioxygenase | TOD | -- | 1.00E+04 U | -- | -- | -- | -- | 1.00E+04 U | -- | -- | -- | -- | -- | -- | -- |
| Phenol Hydroxylase | PHE | -- | 1.00E+04 U | -- | -- | -- | -- | 2.38E+04 | -- | -- | -- | -- | -- | -- | -- |
| Trichlorobenzene Dioxygenase | TCBO | -- | 1.00E+04 U | -- | -- | -- | -- | 1.00E+04 U | -- | -- | -- | -- | -- | -- | -- |
| Toluene Monooxygenase 2 | RDEG | -- | 1.00E+04 U | -- | -- | -- | -- | 1.00E+04 U | -- | -- | -- | -- | -- | -- | -- |
| Toluene Monooxygenase | RMO | -- | 1.00E+04 U | -- | -- | -- | -- | 1.00E+04 U | -- | -- | -- | -- | -- | -- | -- |
| Ethene Monooxygenase | EtnC | -- | 1.00E+04 U | -- | -- | -- | -- | 1.00E+04 U | -- | -- | -- | -- | -- | -- | -- |
| Epoxyalkane transferase | EtnE | -- | 1.00E+04 U | -- | -- | -- | -- | 1.00E+04 U | -- | -- | -- | -- | -- | -- | -- |
| Dichloromethane dehalogenase | DCMA | -- | 1.00E+04 U | -- | -- | -- | -- | 1.00E+04 U | -- | -- | -- | -- | -- | -- | -- |
| Other | | | | | | | | | | | | | | | |
| Total Eubacteria | EBAC | -- | 1.05E+07 | -- | -- | -- | -- | 1.65E+07 | -- | -- | -- | -- | -- | -- | -- |
| Sulfate Reducing Bacteria | APS | -- | 1.00E+04 U | -- | -- | -- | -- | 1.00E+04 U | -- | -- | -- | -- | -- | -- | -- |
| Methanogens | MGN | -- | 1.00E+04 U | -- | -- | -- | -- | 1.00E+04 U | -- | -- | -- | -- | -- | -- | -- |
| CSIA | | $\delta^{13}C$ | $\delta^{13}C$ | $\delta^{13}C$ | $\delta^{13}C$ | $\delta^{13}C$ | $\delta^{13}C$ | $\delta^{13}C$ | $\delta^{13}C$ | $\delta^{13}C$ | $\delta^{13}C$ | $\delta^{13}C$ | $\delta^{13}C$ | $\delta^{13}C$ | $\delta^{13}C$ |
| cis-1,2-dichloroethene | | -- | -- | -- | -- | -- | -16.01 | -- | -- | -- | -- | -- | -- | -- | -- |
| Trichloroethene | | -- | -- | -- | -- | -- | -25.26 | -- | -- | -- | -- | -- | -- | -- | -- |

Notes:

BOLD value indicates the compound was detected above the reporting limit.

U indicates the compound was not detected at the indicated concentration.

J indicates the presence of a compound that meets the identification criteria. The result is less than the quantitation limit but greater than zero, and is given an approximate value.

-- indicates analysis was not performed

U* (CSIA): Either there was no peak corresponding to the target analyte or that such a peak did not produce a reliable CSIA result.

APPENDIX C.2: SOIL ANALYTICAL DATA SUMMARY (TOC, MICROBIAL COMMUNITY AND CSIA)

| Sample ID | DPC-21-20D | DPC-21-22 | DPC-21-22.6 | DPC-22-17.4 | DPC-22-17.8 | DPC-22-17.9 | DPC-22-18.1 | DPC-22-18.9 | DPC-22-21 | DPC-23-17.5 | DPC-23-18 | DPC-23-19 | DPC-23-19.4 | DPC-23-19.6 |
|--|----------------|-----------------|----------------|-------------------|----------------|----------------|----------------|----------------|-----------------|-------------------|----------------|----------------|----------------|----------------|
| Sampling Date | 4/27/2015 | 4/27/2015 | 4/27/2015 | 4/27/2015 | 4/27/2015 | 4/27/2015 | 4/27/2015 | 4/27/2015 | 4/27/2015 | 4/27/2015 | 4/27/2015 | 4/27/2015 | 4/27/2015 | 4/27/2015 |
| SOIL CHEMISTRY | mg/kg | mg/kg | mg/kg | mg/kg | mg/kg | mg/kg | mg/kg | mg/kg | mg/kg | mg/kg | mg/kg | mg/kg | mg/kg | mg/kg |
| Total Organic Carbon (TOC) value | -- | -- | 64.5 | -- | -- | 191 | -- | -- | -- | -- | -- | -- | 98.5 | -- |
| Std Dev | -- | -- | 21.1 | -- | -- | 40.7 | -- | -- | -- | -- | -- | -- | 23.0 | -- |
| MICROBIAL COMMUNITY | cells/g | cells/g | cells/g | cells/g | cells/g | cells/g | cells/g | cells/g | cells/g | cells/g | cells/g | cells/g | cells/g | cells/g |
| Reductive Dechlorination | | | | | | | | | | | | | | |
| <i>Dehalococcoides</i> spp. DHC | -- | 1.00E+03 U | -- | 1.00E+03 U | -- | -- | -- | -- | 1.00E+03 U | 1.00E+03 U | -- | -- | -- | -- |
| tceA Reductase TCE | -- | 1.00E+03 U | -- | 1.00E+03 U | -- | -- | -- | -- | 1.00E+03 U | 1.00E+03 U | -- | -- | -- | -- |
| BAV1 Vinyl Chloride Reductase BVC | -- | 1.00E+03 U | -- | 1.00E+03 U | -- | -- | -- | -- | 1.00E+03 U | 1.00E+03 U | -- | -- | -- | -- |
| Vinyl Chloride Reductase VCR | -- | 1.00E+03 U | -- | 1.00E+03 U | -- | -- | -- | -- | 1.00E+03 U | 1.00E+03 U | -- | -- | -- | -- |
| <i>Dehalobacter</i> spp. DHBt | -- | 1.00E+04 U | -- | 1.00E+04 U | -- | -- | -- | -- | 1.00E+04 U | 1.00E+04 U | -- | -- | -- | -- |
| <i>Dehalobacter</i> DCM | -- | 1.00E+04 U | -- | 1.00E+04 U | -- | -- | -- | -- | 1.00E+04 U | 1.00E+04 U | -- | -- | -- | -- |
| <i>Dehalogenimonas</i> spp. DHG | -- | 1.00E+04 U | -- | 1.00E+04 U | -- | -- | -- | -- | 1.00E+04 U | 1.00E+04 U | -- | -- | -- | -- |
| <i>Desulfitobacterium</i> spp. DSB | -- | 1.00E+04 U | -- | 1.00E+04 U | -- | -- | -- | -- | 1.00E+04 U | 1.00E+04 U | -- | -- | -- | -- |
| <i>Dehalobium chlorocoercia</i> DECO | -- | 1.00E+04 U | -- | 1.00E+04 U | -- | -- | -- | -- | 1.00E+04 U | 1.00E+04 U | -- | -- | -- | -- |
| <i>Desulfuromonas</i> spp. DSM | -- | 2.39E+05 | -- | 1.00E+04 U | -- | -- | -- | -- | 1.00E+04 U | 1.00E+04 U | -- | -- | -- | -- |
| Chloroform reductase CFR | -- | 1.00E+04 U | -- | 1.00E+04 U | -- | -- | -- | -- | 1.00E+04 U | 1.00E+04 U | -- | -- | -- | -- |
| 1,1-DCA Reductase DCA | -- | 1.00E+04 U | -- | 1.00E+04 U | -- | -- | -- | -- | 1.00E+04 U | 1.00E+04 U | -- | -- | -- | -- |
| 1,2-DCA Reductase DCAR | -- | 1.00E+04 U | -- | 1.00E+04 U | -- | -- | -- | -- | 1.00E+04 U | 1.00E+04 U | -- | -- | -- | -- |
| Aerobic Cometabolic | | | | | | | | | | | | | | |
| Soluble Methane Monooxygenase SMMO | -- | 1.00E+04 U | -- | 3.23E+04 | -- | -- | -- | -- | 1.00E+04 U | 6.72E+04 | -- | -- | -- | -- |
| Particulate Methane Monooxygenase PMMO | -- | 3.39E+05 | -- | 8.02E+02 J | -- | -- | -- | -- | 6.59E+06 | 1.00E+04 U | -- | -- | -- | -- |
| Toluene Dioxygenase TOD | -- | 1.00E+04 U | -- | 1.00E+04 U | -- | -- | -- | -- | 1.00E+04 U | 8.08E+02 J | -- | -- | -- | -- |
| Phenol Hydroxylase PHE | -- | 1.00E+04 U | -- | 1.00E+04 U | -- | -- | -- | -- | 1.00E+04 U | 1.00E+04 U | -- | -- | -- | -- |
| Trichlorobenzene Dioxygenase TCBO | -- | 1.00E+04 U | -- | 1.00E+04 U | -- | -- | -- | -- | 1.00E+04 U | 1.00E+04 U | -- | -- | -- | -- |
| Toluene Monooxygenase 2 RDEG | -- | 1.00E+04 U | -- | 5.36E+03 J | -- | -- | -- | -- | 1.00E+04 U | 1.00E+04 U | -- | -- | -- | -- |
| Toluene Monooxygenase RMO | -- | 1.00E+04 U | -- | 1.00E+04 U | -- | -- | -- | -- | 1.00E+04 U | 1.00E+04 U | -- | -- | -- | -- |
| Ethene Monooxygenase EtnC | -- | 1.00E+04 U | -- | 1.00E+04 U | -- | -- | -- | -- | 1.00E+04 U | 1.00E+04 U | -- | -- | -- | -- |
| Epoxyalkane transferase EtnE | -- | 1.00E+04 U | -- | 1.00E+04 U | -- | -- | -- | -- | 1.00E+04 U | 1.00E+04 U | -- | -- | -- | -- |
| Dichloromethane dehalogenase DCMA | -- | 1.00E+04 U | -- | 1.00E+04 U | -- | -- | -- | -- | 1.00E+04 U | 1.00E+04 U | -- | -- | -- | -- |
| Other | | | | | | | | | | | | | | |
| Total Eubacteria EBAC | -- | 2.69E+07 | -- | 1.06E+07 | -- | -- | -- | -- | 1.44E+07 | 2.02E+07 | -- | -- | -- | -- |
| Sulfate Reducing Bacteria APS | -- | 1.00E+04 U | -- | 1.00E+04 U | -- | -- | -- | -- | 1.00E+04 U | 1.00E+04 U | -- | -- | -- | -- |
| Methanogens MGN | -- | 1.00E+04 U | -- | 1.00E+04 U | -- | -- | -- | -- | 1.00E+04 U | 1.00E+04 U | -- | -- | -- | -- |
| CSIA | $\delta^{13}C$ | $\delta^{13}C$ | $\delta^{13}C$ | $\delta^{13}C$ | $\delta^{13}C$ | $\delta^{13}C$ | $\delta^{13}C$ | $\delta^{13}C$ | $\delta^{13}C$ | $\delta^{13}C$ | $\delta^{13}C$ | $\delta^{13}C$ | $\delta^{13}C$ | $\delta^{13}C$ |
| cis-1,2-dichloroethene | -- | -- | -- | -- | -- | -- | -- | -- | -- | -- | -- | -- | -- | -- |
| Trichloroethene | -- | -- | -- | -- | -- | -- | -- | -- | -- | -- | -- | -- | -- | -- |

Notes:

BOLD value indicates the compound was detected above the reporting limit.

U indicates the compound was not detected at the indicated concentration.

J indicates the presence of a compound that meets the identification criteria. The result is less than the quantitation limit but greater than zero, and is given an approximate value.

-- indicates analysis was not performed

U* (CSIA): Either there was no peak corresponding to the target analyte or that such a peak did not produce a reliable CSIA result.

APPENDIX C.2: SOIL ANALYTICAL DATA SUMMARY (TOC, MICROBIAL COMMUNITY AND CSIA)

| Sample ID | | DPC-23-21 | DPC-23-21.2 | DPC-24-17.3 | DPC-24-17.6 | DPC-24-18 | DPC-24-21.3 | DPC-24-21.6 | DPC-24-21.9 | DPC-24-22 |
|-----------------------------------|---------|-----------------------|-----------------------|-----------------------|-----------------------|-----------------------|-----------------------|-----------------------|-----------------------|-----------------------|
| Sampling Date | | 4/27/2015 | 4/27/2015 | 4/28/2015 | 4/27/2015 | 4/28/2015 | 4/28/2015 | 4/28/2015 | 4/28/2015 | 4/28/2015 |
| SOIL CHEMISTRY | | mg/kg | mg/kg | mg/kg | mg/kg | mg/kg | mg/kg | mg/kg | mg/kg | mg/kg |
| Total Organic Carbon (TOC) | value | -- | -- | 117 | -- | -- | -- | 31.3 J | -- | -- |
| | Std Dev | -- | -- | 44.1 | -- | -- | -- | 23.1 | -- | -- |
| MICROBIAL COMMUNITY | | cells/g | cells/g | cells/g | cells/g | cells/g | cells/g | cells/g | cells/g | cells/g |
| Reductive Dechlorination | | | | | | | | | | |
| <i>Dehalococcoides</i> spp. | DHC | -- | 1.00E+03 U | -- | 1.00E+03 U | -- | 1.00E+03 U | -- | -- | -- |
| tceA Reductase | TCE | -- | 1.00E+03 U | -- | 1.00E+03 U | -- | 1.00E+03 U | -- | -- | -- |
| BAV1 Vinyl Chloride Reductase | BVC | -- | 1.00E+03 U | -- | 1.00E+03 U | -- | 1.00E+03 U | -- | -- | -- |
| Vinyl Chloride Reductase | VCR | -- | 1.00E+03 U | -- | 1.00E+03 U | -- | 1.00E+03 U | -- | -- | -- |
| <i>Dehalobacter</i> spp. | DHBt | -- | 1.00E+04 U | -- | 1.00E+04 U | -- | 1.00E+04 U | -- | -- | -- |
| <i>Dehalobacter</i> DCM | DCM | -- | 1.00E+04 U | -- | 1.00E+04 U | -- | 1.00E+04 U | -- | -- | -- |
| <i>Dehalogenimonas</i> spp. | DHG | -- | 1.00E+04 U | -- | 1.00E+04 U | -- | 1.00E+04 U | -- | -- | -- |
| <i>Desulfitobacterium</i> spp. | DSB | -- | 1.00E+04 U | -- | 1.00E+04 U | -- | 1.00E+04 U | -- | -- | -- |
| <i>Dehalobium chlorocoercia</i> | DECO | -- | 1.00E+04 U | -- | 1.00E+04 U | -- | 1.00E+04 U | -- | -- | -- |
| <i>Desulfuromonas</i> spp. | DSM | -- | 1.00E+04 U | -- | 1.00E+04 U | -- | 1.00E+04 U | -- | -- | -- |
| Chloroform reductase | CFR | -- | 1.00E+04 U | -- | 1.00E+04 U | -- | 1.00E+04 U | -- | -- | -- |
| 1,1-DCA Reductase | DCA | -- | 1.00E+04 U | -- | 1.00E+04 U | -- | 1.00E+04 U | -- | -- | -- |
| 1,2-DCA Reductase | DCAR | -- | 1.00E+04 U | -- | 1.00E+04 U | -- | 1.00E+04 U | -- | -- | -- |
| Aerobic Cometabolic | | | | | | | | | | |
| Soluble Methane Monooxygenase | SMMO | -- | 1.00E+04 U | -- | 1.00E+04 U | -- | 1.00E+04 U | -- | -- | -- |
| Particulate Methane Monooxygenase | PMMO | -- | 3.06E+02 J | -- | 1.19E+04 | -- | 2.72E+03 J | -- | -- | -- |
| Toluene Dioxygenase | TOD | -- | 9.34E+03 J | -- | 1.45E+03 J | -- | 3.52E+04 | -- | -- | -- |
| Phenol Hydroxylase | PHE | -- | 1.00E+04 U | -- | 1.00E+04 U | -- | 1.00E+04 U | -- | -- | -- |
| Trichlorobenzene Dioxygenase | TCBO | -- | 1.00E+04 U | -- | 1.00E+04 U | -- | 1.00E+04 U | -- | -- | -- |
| Toluene Monooxygenase 2 | RDEG | -- | 1.00E+04 U | -- | 2.24E+03 J | -- | 1.00E+04 U | -- | -- | -- |
| Toluene Monooxygenase | RMO | -- | 1.00E+04 U | -- | 1.00E+04 U | -- | 1.00E+04 U | -- | -- | -- |
| Ethene Monooxygenase | EtnC | -- | 1.00E+04 U | -- | 1.00E+04 U | -- | 1.00E+04 U | -- | -- | -- |
| Epoxyalkane transferase | EtnE | -- | 1.00E+04 U | -- | 1.00E+04 U | -- | 1.00E+04 U | -- | -- | -- |
| Dichloromethane dehalogenase | DCMA | -- | 1.00E+04 U | -- | 1.00E+04 U | -- | 1.00E+04 U | -- | -- | -- |
| Other | | | | | | | | | | |
| Total Eubacteria | EBAC | -- | 1.37E+08 | -- | 2.23E+07 | -- | 1.05E+07 | -- | -- | -- |
| Sulfate Reducing Bacteria | APS | -- | 1.00E+04 U | -- | 1.00E+04 U | -- | 1.00E+04 U | -- | -- | -- |
| Methanogens | MGN | -- | 1.00E+04 U | -- | 1.00E+04 U | -- | 1.00E+04 U | -- | -- | -- |
| CSIA | | $\delta^{13}\text{C}$ | $\delta^{13}\text{C}$ | $\delta^{13}\text{C}$ | $\delta^{13}\text{C}$ | $\delta^{13}\text{C}$ | $\delta^{13}\text{C}$ | $\delta^{13}\text{C}$ | $\delta^{13}\text{C}$ | $\delta^{13}\text{C}$ |
| cis-1,2-dichloroethene | | -- | -- | -- | U* | -- | -- | -- | U* | -- |
| Trichloroethene | | -- | -- | -- | -24.36 | -- | -- | -- | -25.66 | -- |

Notes:

BOLD value indicates the compound was detected above the reporting limit.

U indicates the compound was not detected at the indicated concentration.

J indicates the presence of a compound that meets the identification criteria. The result is less than the quantitation limit but greater than zero, and is given an approximate value.

-- indicates analysis was not performed

U* (CSIA): Either there was no peak corresponding to the target analyte or that such a peak did not produce a reliable CSIA result.

Page Intentionally Left Blank

**APPENDIX D GROUNDWATER ANALYTICAL DATA SUMMARY
TABLES**

APPENDIX D.1: GROUNDWATER ANALYTICAL DATA SUMMARY (VOCs)

| Sample ID | MW360-5 | MW360-5 | MW360-5 | SIW01 | SIW01 | SIW02 | SIW02 | SIW02 | SIW03 | SIW03 | SIW03 | SMLS1-1 | SMLS1-1 | SMLS1-1 | SMLS1-2 | SMLS1-2 | SMLS1-2 | SMLS1-3 | SMLS1-3 |
|-----------------------------|---------------|--------------|---------------|--------------|--------------|---------------|--------------|---------------|--------------|--------------|----------------|----------------|---------------|----------------|----------------|----------------|-----------------|-----------------|----------------|
| Sampling Date | 3/17/2015 | 12/9/2015 | 8/11/2016 | 3/16/2015 | 12/8/2015 | 3/16/2015 | 12/8/2015 | 8/11/2016 | 3/16/2015 | 12/8/2015 | 3/16/2015 | 3/17/2015 | 12/3/2015 | 8/11/2016 | 12/3/2015 | 8/11/2016 | 3/17/2015 | 12/3/2015 | 8/11/2016 |
| VOCs (GC/MS) | µg/L | µg/L | µg/L | µg/L | µg/L | µg/L | µg/L | µg/L | µg/L | µg/L | µg/L | µg/L | µg/L | µg/L | µg/L | µg/L | µg/L | µg/L | µg/L |
| dichlorodifluoromethane | 21.0 U | 5.0 U | 5.0 U | 5.0 U | 5.0 U | 21.0 U | 5.0 U | 5.0 U | 5.0 U | 5.0 U | 5.0 U | 21.0 U | 5.0 U | 5.0 U | 21.0 U | 42.0 U | 42.0 U | 525 U | 42.0 U |
| chloromethane | 21.0 U | 5.0 U | 5.0 U | 5.0 U | 5.0 U | 21.0 U | 5.0 U | 5.0 U | 5.0 U | 5.0 U | 5.0 U | 21.0 U | 5.0 U | 5.0 U | 21.0 U | 42.0 U | 42.0 U | 525 U | 42.0 U |
| vinyl chloride | 21.0 U | 5.6 | 4.09 J | 0.6 J | 5.0 U | 21.0 U | 5.0 U | 5.0 U | 0.6 J | 0.9 J | 4350 D | 2240 D | 7960 D | 13300 D | 13800 D | 17900 D | 7096 D | 52300 D | |
| bromomethane | 21.0 U | 5.0 U | 5.0 U | 5.0 U | 5.0 U | 21.0 U | 5.0 U | 5.0 U | 5.0 U | 5.0 U | 5.0 U | 21.0 U | 5.0 U | 5.0 U | 21.0 U | 42.0 U | 42.0 U | 525 U | 42.0 U |
| chloroethane | 21.0 U | 5.0 U | 5.0 U | 5.0 U | 0.8 J | 21.0 U | 5.0 U | 5.0 U | 5.0 U | 5.0 U | 5.0 U | 21.0 U | 5.0 U | 5.0 U | 21.0 U | 42.0 U | 42.0 U | 525 U | 42.0 U |
| trichlorofluoromethane | 21.0 U | 5.0 U | 5.0 U | 5.0 U | 5.0 U | 21.0 U | 5.0 U | 5.0 U | 5.0 U | 5.0 U | 5.0 U | 21.0 U | 5.0 U | 5.0 U | 21.0 U | 42.0 U | 42.0 U | 525 U | 42.0 U |
| 1,1-dichloroethylene | 3.1 JD | 4.3 J | 4.13 J | 5.0 U | 5.0 U | 21.0 U | 5.0 U | 5.0 U | 5.0 U | 5.0 U | 5.0 U | 3.8 JD | 1.3 J | 11.8 | 26.5 D | 10.1 JD | 27.6 JD | 96.6 JD | 89.6 D |
| methylene chloride | 21.0 U | 5.0 U | 5.0 U | 5.0 U | 5.0 U | 21.0 U | 5.0 U | 5.0 U | 5.0 U | 5.0 U | 5.0 U | 21.0 U | 5.0 U | 5.0 U | 21.0 U | 42.0 U | 42.0 U | 525 U | 4.4 JD |
| trans-1,2-dichloroethylene | 64.2 D | 114 | 215 D | 5.0 U | 5.0 U | 21.0 U | 5.0 U | 5.0 U | 5.0 U | 5.0 U | 5.0 U | 28.8 D | 10.4 | 58.8 | 73.0 D | 28.3 JD | 80.9 D | 212 JD | 229 D |
| 1,1-dichloroethane | 21.0 U | 5.0 U | 5.0 U | 5.0 U | 5.0 U | 21.0 U | 5.0 U | 5.0 U | 5.0 U | 5.0 U | 5.0 U | 21.0 U | 5.0 U | 5.0 U | 21.0 U | 42.0 U | 42.0 U | 525 U | 42.0 U |
| 2,2-dichloropropane | 21.0 U | 5.0 U | 5.0 U | 5.0 U | 5.0 U | 21.0 U | 5.0 U | 5.0 U | 5.0 U | 5.0 U | 5.0 U | 21.0 U | 5.0 U | 5.0 U | 21.0 U | 42.0 U | 42.0 U | 525 U | 42.0 U |
| cis 1,2- dichloroethylene | 155 D | 215 D | 238 D | 5.0 U | 5.0 U | 21.0 U | 5.0 U | 5.0 U | 0.7 J | 5.0 U | 2360 D | 565 D | 5250 D | 22200 D | 9730 D | 23500 D | 130000 D | 122000 D | |
| bromochloromethane | 21.0 U | 5.0 U | 5.0 U | 5.0 U | 5.0 U | 21.0 U | 5.0 U | 5.0 U | 5.0 U | 5.0 U | 5.0 U | 21.0 U | 5.0 U | 5.0 U | 21.0 U | 42.0 U | 42.0 U | 525 U | 42.0 U |
| chloroform | 21.0 U | 5.0 U | 5.0 U | 5.0 U | 5.0 U | 21.0 U | 5.0 U | 5.0 U | 5.0 U | 5.0 U | 5.0 U | 21.0 U | 5.0 U | 5.0 U | 21.0 U | 42.0 U | 42.0 U | 525 U | 42.0 U |
| 1,1,1-trichloroethane | 21.0 U | 5.0 U | 5.0 U | 5.0 U | 5.0 U | 21.0 U | 5.0 U | 5.0 U | 5.0 U | 5.0 U | 5.0 U | 21.0 U | 5.0 U | 5.0 U | 21.0 U | 42.0 U | 42.0 U | 525 U | 42.0 U |
| carbon tetrachloride | 21.0 U | 5.0 U | 5.0 U | 5.0 U | 5.0 U | 21.0 U | 5.0 U | 5.0 U | 5.0 U | 5.0 U | 5.0 U | 21.0 U | 5.0 U | 5.0 U | 21.0 U | 42.0 U | 42.0 U | 525 U | 42.0 U |
| 1,1-dichloropropene | 21.0 U | 5.0 U | 5.0 U | 5.0 U | 5.0 U | 21.0 U | 5.0 U | 5.0 U | 5.0 U | 5.0 U | 5.0 U | 21.0 U | 5.0 U | 5.0 U | 21.0 U | 42.0 U | 42.0 U | 525 U | 42.0 U |
| benzene | 21.0 U | 5.0 U | 5.0 U | 5.0 U | 5.0 U | 21.0 U | 5.0 U | 5.0 U | 5.0 U | 5.0 U | 5.0 U | 21.0 U | 5.0 U | 5.0 U | 21.0 U | 42.0 U | 42.0 U | 525 U | 42.0 U |
| 1,2-dichloroethane | 21.0 U | 5.0 U | 5.0 U | 5.0 U | 5.0 U | 21.0 U | 5.0 U | 5.0 U | 5.0 U | 5.0 U | 5.0 U | 21.0 U | 5.0 U | 5.0 U | 21.0 U | 42.0 U | 42.0 U | 525 U | 42.0 U |
| trichloroethylene | 992 D | 813 D | 792 D | 5.0 U | 5.0 U | 21.0 U | 5.0 U | 5.0 U | 5.0 U | 5.0 U | 5.0 U | 68.7 D | 3.2 J | 136 | 153 D | 77.0 D | 1200 D | 3220 D | 1480 D |
| 1,2-dichloropropane | 21.0 U | 5.0 U | 5.0 U | 5.0 U | 5.0 U | 21.0 U | 5.0 U | 5.0 U | 5.0 U | 5.0 U | 5.0 U | 21.0 U | 5.0 U | 5.0 U | 21.0 U | 42.0 U | 42.0 U | 525 U | 42.0 U |
| dibromomethane | 21.0 U | 5.0 U | 5.0 U | 5.0 U | 5.0 U | 21.0 U | 5.0 U | 5.0 U | 5.0 U | 5.0 U | 5.0 U | 21.0 U | 5.0 U | 5.0 U | 21.0 U | 42.0 U | 42.0 U | 525 U | 42.0 U |
| bromodichloromethane | 21.0 U | 5.0 U | 5.0 U | 5.0 U | 5.0 U | 21.0 U | 5.0 U | 5.0 U | 5.0 U | 5.0 U | 5.0 U | 21.0 U | 5.0 U | 5.0 U | 21.0 U | 42.0 U | 42.0 U | 525 U | 42.0 U |
| cis-1,3-dichloropropene | 21.0 U | 5.0 U | 5.0 U | 5.0 U | 5.0 U | 21.0 U | 5.0 U | 5.0 U | 5.0 U | 5.0 U | 5.0 U | 21.0 U | 5.0 U | 5.0 U | 21.0 U | 42.0 U | 42.0 U | 525 U | 42.0 U |
| toluene | 21.0 U | 5.0 U | 5.0 U | 5.0 U | 5.0 U | 21.0 U | 5.0 U | 1.09 J | 5.0 U | 5.0 U | 4.5 JD | 3.6 J | 3.3 J | 5.3 JD | 42.0 U | 42.0 U | 525 U | 18.2 JD | |
| trans-1,3-dichloropropene | 21.0 U | 5.0 U | 5.0 U | 5.0 U | 5.0 U | 21.0 U | 5.0 U | 5.0 U | 5.0 U | 5.0 U | 5.0 U | 21.0 U | 5.0 U | 5.0 U | 21.0 U | 42.0 U | 42.0 U | 525 U | 42.0 U |
| 1,1,2-trichloroethane | 21.0 U | 5.0 U | 5.0 U | 5.0 U | 5.0 U | 21.0 U | 5.0 U | 5.0 U | 5.0 U | 5.0 U | 5.0 U | 21.0 U | 5.0 U | 5.0 U | 21.0 U | 42.0 U | 42.0 U | 525 U | 42.0 U |
| tetrachloroethylene | 21.0 U | 5.0 U | 5.0 U | 5.0 U | 5.0 U | 21.0 U | 5.0 U | 5.0 U | 5.0 U | 5.0 U | 5.0 U | 21.0 U | 5.0 U | 5.0 U | 21.0 U | 42.0 U | 42.0 U | 525 U | 42.0 U |
| 1,3-dichloropropane | 21.0 U | 5.0 U | 5.0 U | 5.0 U | 5.0 U | 21.0 U | 5.0 U | 5.0 U | 5.0 U | 5.0 U | 5.0 U | 21.0 U | 5.0 U | 5.0 U | 21.0 U | 42.0 U | 42.0 U | 525 U | 42.0 U |
| dibromochloromethane | 21.0 U | 5.0 U | 5.0 U | 5.0 U | 5.0 U | 21.0 U | 5.0 U | 5.0 U | 5.0 U | 5.0 U | 5.0 U | 21.0 U | 5.0 U | 5.0 U | 21.0 U | 42.0 U | 42.0 U | 525 U | 42.0 U |
| 1,2-dibromoethane | 21.0 U | 5.0 U | 5.0 U | 5.0 U | 5.0 U | 21.0 U | 5.0 U | 5.0 U | 5.0 U | 5.0 U | 5.0 U | 21.0 U | 5.0 U | 5.0 U | 21.0 U | 42.0 U | 42.0 U | 525 U | 42.0 U |
| chlorobenzene | 21.0 U | 5.0 U | 5.0 U | 158 | 150 | 73.3 D | 62.1 | 58.8 | 57.7 | 48.1 | 1300 D | 1100 D | 827 D | 704 D | 435 D | 542 D | 1010 D | 608 D | |
| 1,1,1,2-tetrachloroethane | 21.0 U | 5.0 U | 5.0 U | 5.0 U | 5.0 U | 21.0 U | 5.0 U | 5.0 U | 5.0 U | 5.0 U | 5.0 U | 21.0 U | 5.0 U | 5.0 U | 21.0 U | 42.0 U | 42.0 U | 525 U | 42.0 U |
| ethylbenzene | 21.0 U | 5.0 U | 5.0 U | 5.0 U | 5.0 U | 21.0 U | 5.0 U | 5.0 U | 5.0 U | 5.0 U | 5.0 U | 21.0 U | 1.6 J | 5.0 U | 21.0 U | 42.0 U | 42.0 U | 525 U | 42.0 U |
| xylenes (m/p) | 42.0 U | 10.0 U | 10.0 U | 10.0 U | 10.0 U | 42.0 U | 10.0 U | 10.0 U | 10.0 U | 10.0 U | 10.0 U | 5.7 JD | 4.7 J | 3.92 J | 6.3 JD | 84.0 U | 84.0 U | 1050 U | 16.5 JD |
| o-xylene | 21.0 U | 5.0 U | 5.0 U | 5.0 U | 5.0 U | 21.0 U | 5.0 U | 5.0 U | 5.0 U | 5.0 U | 5.0 U | 4.8 JD | 4.3 J | 3.33 J | 4.0 JD | 42.0 U | 42.0 U | 525 U | 10.2 JD |
| styrene | 21.0 U | 5.0 U | 5.0 U | 5.0 U | 5.0 U | 21.0 U | 5.0 U | 5.0 U | 5.0 U | 5.0 U | 5.0 U | 21.0 U | 5.0 U | 5.0 U | 21.0 U | 42.0 U | 42.0 U | 525 U | 42.0 U |
| bromoform | 21.0 U | 5.0 U | 5.0 U | 5.0 U | 5.0 U | 21.0 U | 5.0 U | 5.0 U | 5.0 U | 5.0 U | 5.0 U | 21.0 U | 5.0 U | 5.0 U | 21.0 U | 42.0 U | 42.0 U | 525 U | 42.0 U |
| isopropyl benzene (cumene) | 21.0 U | 5.0 U | 5.0 U | 5.0 U | 5.0 U | 21.0 U | 5.0 U | 5.0 U | 5.0 U | 5.0 U | 5.0 U | 3.2 JD | 3.3 J | 2.99 | 2.9 JD | 42.0 U | 42.0 U | 525 U | 42.0 U |
| bromobenzene | 21.0 U | 5.0 U | 5.0 U | 5.0 U | 5.0 U | 21.0 U | 5.0 U | 5.0 U | 5.0 U | 5.0 U | 5.0 U | 21.0 U | 5.0 U | 5.0 U | 21.0 U | 42.0 U | 42.0 U | 525 U | 42.0 U |
| 1,1,1,2-tetrachloroethane | 21.0 U | 5.0 U | 5.0 U | 5.0 U | 5.0 U | 21.0 U | 5.0 U | 5.0 U | 5.0 U | 5.0 U | 5.0 U | 21.0 U | 5.0 U | 5.0 U | 21.0 U | 42.0 U | 42.0 U | 525 U | 42.0 U |
| 1,2,3-trichloropropane | 21.0 U | 5.0 U | 5.0 U | 5.0 U | 5.0 U | 21.0 U | 5.0 U | 5.0 U | 5.0 U | 5.0 U | 5.0 U | 21.0 U | 5.0 U | 5.0 U | 21.0 U | 42.0 U | 42.0 U | 525 U | 42.0 U |
| n-propyl benzene | 21.0 U | 5.0 U | 5.0 U | 5.0 U | 5.0 U | 21.0 U | 5.0 U | 5.0 U | 5.0 U | 5.0 U | 5.0 U | 3.1 JD | 3.2 J | 3.10 | 3.1 JD | 42.0 U | 42.0 U | 525 U | 4.5 JD |
| 2-chlorotoluene | 21.0 U | 5.0 U | 5.0 U | 5.0 U | 5.0 U | 21.0 U | 5.0 U | 5.0 U | 5.0 U | 5.0 U | 5.0 U | 21.0 U | 5.0 U | 5.0 U | 21.0 U | 42.0 U | 42.0 U | 525 U | 42.0 U |
| 4-chlorotoluene | 21.0 U | 5.0 U | 5.0 U | 5.0 U | 5.0 U | 21.0 U | 5.0 U | 5.0 U | 5.0 U | 5.0 U | 5.0 U | 21.0 U | 5.0 U | 5.0 U | 21.0 U | 42.0 U | 42.0 U | 525 U | 42.0 U |
| 1,3,5-trimethylbenzene | 21.0 U | 5.0 U | 5.0 U | 5.0 U | 5.0 U | 21.0 U | 5.0 U | 5.0 U | 5.0 U | 5.0 U | 5.0 U | 3.7 JD | 3.7 J | 3.25 J | 4.3 JD | 42.0 U | 42.0 U | 525 U | 11.6 JD |
| tert-butylbenzene | 21.0 U | 5.0 U | 5.0 U | 5.0 U | 5.0 U | 21.0 U | 5.0 U | 5.0 U | 5.0 U | 5.0 U | 5.0 U | 21.0 U | 5.0 U | 5.0 U | 21.0 U | 42.0 U | 42.0 U | 525 U | 42.0 U |
| 1,2,4-trimethylbenzene | 21.0 U | 5.0 U | 5.0 U | 0.8 J | 0.7 J | 21.0 U | 5.0 U | 5.0 U | 5.0 U | 5.0 U | 5.0 U | 13.2 JD | 6.8 | 1.53 J | 11.3 JD | 42.0 U | 9.83 JD | 61 JD | 42.8 D |
| sec-butylbenzene | 21.0 U | 5.0 U | 5.0 U | 0.6 J | 5.0 U | 21.0 U | 5.0 U | 5.0 U | 5.0 U | 5.0 U | 5.0 U | 2.1 JD | 2.5 J | 2.54 J | 2.9 JD | 42.0 U | 42.0 U | 525 U | 42.0 U |
| 1,3-dichlorobenzene | 21.0 U | 5.0 U | 5.0 U | 2.8 J | 2.0 J | 21.0 U | 1.0 J | 0.8 J | 0.9 J | 0.7 J | 14.0 JD | 14.7 | 13.0 | 12.4 JD | 8.1 JD | 8.99 JD | 525 U | 13.4 JD | |
| 4-isopropyltoluene | 21.0 U | 5.0 U | 5.0 U | 5.0 U | 5.0 U | 21.0 U | 5.0 U | 5.0 U | 5.0 U | 5.0 U | 5.0 U | 21.0 U | 1.2 J | 5.0 U | 21.0 U | 42.0 U | 42.0 U | 525 U | 42.0 U |
| 1,4-dichlorobenzene | 21.0 U | 5.0 U | 5.0 U | 12.9 | 10.7 | 7.1 JD | 5.7 | 5.95 | 5.2 | 3.7 J | 100 D | 99.9 | 97.1 | 92.0 D | 63.7 D | 90.1 D | 241 JD | 152.0 D | |
| 1,2-dichlorobenzene | 21.0 U | 5.0 U | 5.0 U | 4.6 J | 2.8 J | 4.8 JD | 2.6 J | 2.60 J | 2.8 J | 2.0 J | 175 D | 140 | 205 | 254 D | 190 D | 431 D | 1340 D | 1000 D | |
| n-butylbenzene | 21.0 U | 5.0 U | 5.0 U | 5.0 U | 5.0 U | 21.0 U | 5.0 U | 5.0 U | 5.0 U | 5.0 U | 5.0 U | 21.0 U | 5.0 U | 5.0 U | 21.0 U | 42.0 U | 42.0 U | 525 U | 42.0 U |
| 1,2-dibromo-3-chloropropane | 21.0 U | 5.0 U | 5.0 U | 5.0 U | 5.0 U | 21.0 U | 5.0 U | 5.0 U | 5.0 U | 5.0 U | 5.0 U | 21.0 U | 5.0 U | 5.0 U | 21.0 U | 42.0 U | 42.0 U | 525 U | 42.0 U |
| 1,2,4-trichlorobenzene | 21.0 U | 5.0 U | 5.0 U | 5.0 U | 5.0 U | 21.0 U | 5.0 U | 5.0 U | 5.0 U | 5.0 U | 5.0 U | 21.0 U | | | | | | | |

APPENDIX D.1: GROUNDWATER ANALYTICAL DATA SUMMARY (VOCs)

| Sample ID | SMLS1-3 | SMLS1-4 | SMLS1-4 | SMLS1-4 | SMLS1-5 | SMLS1-5 | SMLS1-5 | SMLS1-6 | SMLS1-6 | SMLS1-6 | SMLS1-7 | SMLS1-7 | SMLS1-7 | SMLS2-1 | SMLS2-1 | SMLS2-1 | SMLS2-2 | SMLS2-2 | SMLS2-2 | SMLS2-2 |
|----------------------------|----------------|----------------|---------------|----------------|--------------|--------------|---------------|----------------|--------------|---------------|----------------|--------------|---------------|----------------|--------------|---------------|---------------|--------------|---------------|---------------|
| Sampling Date | 8/11/2016 | 3/18/2015 | 12/3/2015 | 8/11/2016 | 3/18/2015 | 12/3/2015 | 8/11/2016 | 3/17/2015 | 12/3/2015 | 8/11/2016 | 3/18/2015 | 12/3/2015 | 8/11/2016 | 3/24/2015 | 12/7/2015 | 8/3/2016 | 3/24/2015 | 12/7/2015 | 8/3/2016 | 3/24/2015 |
| VOCs (GC/MS) | µg/L | µg/L | µg/L | µg/L | µg/L | µg/L | µg/L | µg/L | µg/L | µg/L | µg/L | µg/L | µg/L | µg/L | µg/L | µg/L | µg/L | µg/L | µg/L | µg/L |
| dichlorodifluoromethane | 42.0 U | 21.0 U | 5.0 U | 42.0 U | 5.0 U | 5.0 U | 5.0 U | 21.0 U | 5.0 U | 5.0 U | 21.0 U | 5.0 U | 5.0 U | 21.0 U | 5.0 U | 5.0 U | 5.0 U | 5.0 U | 5.0 U | 5.0 U |
| chloromethane | 42.0 U | 21.0 U | 5.0 U | 42.0 U | 5.0 U | 5.0 U | 5.0 U | 21.0 U | 5.0 U | 5.0 U | 21.0 U | 5.0 U | 5.0 U | 21.0 U | 5.0 U | 5.0 U | 5.0 U | 1.8 J | 4.3 J | 5.0 U |
| vinyl chloride | 22700 D | 3700 D | 4480 D | 1730 D | 61.9 | 186 | 34.7 | 623 D | 458 D | 99.5 | 7840 D | 39.1 | 6.25 | 143 D | 854 D | 195 | 320 D | 359 D | 231 D | |
| bromomethane | 42.0 U | 21.0 U | 5.0 U | 42.0 U | 5.0 U | 5.0 U | 5.0 U | 21.0 U | 5.0 U | 5.0 U | 21.0 U | 5.0 U | 5.0 U | 21.0 U | 5.0 U | 5.0 U | 5.0 U | 5.0 U | 5.0 U | 5.0 U |
| chloroethane | 42.0 U | 21.0 U | 5.0 U | 42.0 U | 5.0 U | 5.0 U | 5.0 U | 21.0 U | 5.0 U | 5.0 U | 21.0 U | 5.0 U | 5.0 U | 21.0 U | 5.0 U | 5.0 U | 5.0 U | 5.0 U | 5.0 U | 5.0 U |
| trichlorofluoromethane | 42.0 U | 21.0 U | 5.0 U | 42.0 U | 5.0 U | 5.0 U | 5.0 U | 21.0 U | 5.0 U | 5.0 U | 21.0 U | 5.0 U | 5.0 U | 21.0 U | 5.0 U | 5.0 U | 5.0 U | 5.0 U | 5.0 U | 5.0 U |
| 1,1-dichloroethylene | 55.0 D | 8.2 JD | 8.0 | 42.0 U | 5.0 U | 5.0 U | 5.0 U | 21.0 U | 5.0 U | 5.0 U | 15.4 JD | 5.0 U | 5.0 U | 21.0 U | 5.0 U | 5.0 U | 0.8 J | 5.0 U | 5.0 U | 5.0 U |
| methylene chloride | 42.0 U | 21.0 U | 5.0 U | 42.0 U | 5.0 U | 5.0 U | 5.0 U | 21.0 U | 5.0 U | 5.0 U | 21.0 U | 5.0 U | 5.0 U | 21.0 U | 5.0 U | 5.0 U | 5.0 U | 5.0 U | 5.0 U | 5.0 U |
| trans-1,2-dichloroethylene | 301 D | 10.0 JD | 11.4 | 42.0 U | 1.0 J | 1.0 J | 5.0 U | 5.7 JD | 3.4 J | 5.0 U | 72.2 D | 5.0 U | 5.0 U | 12.3 JD | 13.2 | 3.63 J | 10.2 | 3.8 J | 4.07 J | |
| 1,1-dichloroethane | 42.0 U | 21.0 U | 5.0 U | 42.0 U | 5.0 U | 2.2 J | 2.16 J | 21.0 U | 5.0 U | 1.45 J | 21.0 U | 5.0 U | 5.0 U | 21.0 U | 5.0 U | 5.0 U | 5.0 U | 5.0 U | 1.6 J | 1.74 J |
| 2,2-dichloropropane | 42.0 U | 21.0 U | 5.0 U | 42.0 U | 5.0 U | 5.0 U | 5.0 U | 21.0 U | 5.0 U | 5.0 U | 21.0 U | 5.0 U | 5.0 U | 21.0 U | 5.0 U | 5.0 U | 5.0 U | 5.0 U | 5.0 U | 5.0 U |
| cis 1,2-dichloroethylene | 70200 D | 6560 D | 6170 D | 2490 D | 96.7 | 158 | 33.1 | 2240 D | 546 D | 91.5 | 19030 D | 31.2 | 4.82 J | 781 D | 411 D | 66.8 | 404 D | 153 | 74.9 | |
| bromochloromethane | 42.0 U | 21.0 U | 5.0 U | 42.0 U | 5.0 U | 5.0 U | 5.0 U | 21.0 U | 5.0 U | 5.0 U | 21.0 U | 5.0 U | 5.0 U | 21.0 U | 5.0 U | 5.0 U | 5.0 U | 5.0 U | 5.0 U | 5.0 U |
| chloroform | 42.0 U | 21.0 U | 5.0 U | 42.0 U | 5.0 U | 5.0 U | 5.0 U | 21.0 U | 5.0 U | 5.0 U | 21.0 U | 5.0 U | 5.0 U | 21.0 U | 5.0 U | 5.0 U | 5.0 U | 5.0 U | 5.0 U | 5.0 U |
| 1,1,1-trichloroethane | 42.0 U | 21.0 U | 5.0 U | 42.0 U | 5.0 U | 5.0 U | 5.0 U | 21.0 U | 5.0 U | 5.0 U | 21.0 U | 5.0 U | 5.0 U | 21.0 U | 5.0 U | 5.0 U | 5.0 U | 5.0 U | 5.0 U | 5.0 U |
| carbon tetrachloride | 42.0 U | 21.0 U | 5.0 U | 42.0 U | 5.0 U | 5.0 U | 5.0 U | 21.0 U | 5.0 U | 5.0 U | 21.0 U | 5.0 U | 5.0 U | 21.0 U | 5.0 U | 5.0 U | 5.0 U | 5.0 U | 5.0 U | 5.0 U |
| 1,1-dichloropropene | 42.0 U | 21.0 U | 5.0 U | 42.0 U | 5.0 U | 5.0 U | 5.0 U | 21.0 U | 5.0 U | 5.0 U | 21.0 U | 5.0 U | 5.0 U | 21.0 U | 5.0 U | 5.0 U | 5.0 U | 5.0 U | 5.0 U | 5.0 U |
| benzene | 42.0 U | 21.0 U | 5.0 U | 42.0 U | 5.0 U | 5.0 U | 5.0 U | 21.0 U | 5.0 U | 5.0 U | 21.0 U | 5.0 U | 5.0 U | 21.0 U | 5.0 U | 5.0 U | 5.0 U | 5.0 U | 5.0 U | 5.0 U |
| 1,2-dichloroethane | 42.0 U | 21.0 U | 5.0 U | 42.0 U | 5.0 U | 5.0 U | 5.0 U | 21.0 U | 5.0 U | 5.0 U | 21.0 U | 5.0 U | 5.0 U | 21.0 U | 5.0 U | 5.0 U | 5.0 U | 5.0 U | 5.0 U | 5.0 U |
| trichloroethylene | 4780 D | 2.5 JD | 4.9 J | 42.0 U | 0.7 J | 5.0 U | 5.0 U | 8.3 JD | 2.9 J | 0.92 J | 65.3 D | 5.0 U | 5.0 U | 30.9 D | 20.4 | 3.44 J | 3.0 J | 1.3 J | 3.81 J | |
| 1,2-dichloropropane | 42.0 U | 21.0 U | 5.0 U | 42.0 U | 5.0 U | 5.0 U | 5.0 U | 21.0 U | 5.0 U | 5.0 U | 21.0 U | 5.0 U | 5.0 U | 21.0 U | 5.0 U | 5.0 U | 5.0 U | 5.0 U | 5.0 U | 5.0 U |
| dibromomethane | 42.0 U | 21.0 U | 5.0 U | 42.0 U | 5.0 U | 5.0 U | 5.0 U | 21.0 U | 5.0 U | 5.0 U | 21.0 U | 5.0 U | 5.0 U | 21.0 U | 5.0 U | 5.0 U | 5.0 U | 5.0 U | 5.0 U | 5.0 U |
| bromodichloromethane | 42.0 U | 21.0 U | 5.0 U | 42.0 U | 5.0 U | 5.0 U | 5.0 U | 21.0 U | 5.0 U | 5.0 U | 21.0 U | 5.0 U | 5.0 U | 21.0 U | 5.0 U | 5.0 U | 5.0 U | 5.0 U | 5.0 U | 5.0 U |
| cis-1,3-dichloropropene | 42.0 U | 21.0 U | 5.0 U | 42.0 U | 5.0 U | 5.0 U | 5.0 U | 21.0 U | 5.0 U | 5.0 U | 21.0 U | 5.0 U | 5.0 U | 21.0 U | 5.0 U | 5.0 U | 5.0 U | 5.0 U | 5.0 U | 5.0 U |
| toluene | 14.5 JD | 21.0 U | 1.2 J | 42.0 U | 5.0 U | 5.0 U | 5.0 U | 21.0 U | 5.0 U | 5.0 U | 4.0 JD | 5.0 U | 5.0 U | 21.0 U | 5.0 U | 1.9 J | 1.16 J | 1.3 J | 0.7 J | 5.0 U |
| trans-1,3-dichloropropene | 42.0 U | 21.0 U | 5.0 U | 42.0 U | 5.0 U | 5.0 U | 5.0 U | 21.0 U | 5.0 U | 5.0 U | 21.0 U | 5.0 U | 5.0 U | 21.0 U | 5.0 U | 5.0 U | 5.0 U | 5.0 U | 5.0 U | 5.0 U |
| 1,1,2-trichloroethane | 42.0 U | 21.0 U | 5.0 U | 42.0 U | 5.0 U | 5.0 U | 5.0 U | 21.0 U | 5.0 U | 5.0 U | 21.0 U | 5.0 U | 5.0 U | 21.0 U | 5.0 U | 5.0 U | 5.0 U | 5.0 U | 5.0 U | 5.0 U |
| tetrachloroethylene | 42.0 U | 21.0 U | 5.0 U | 42.0 U | 5.0 U | 5.0 U | 5.0 U | 21.0 U | 5.0 U | 5.0 U | 21.0 U | 5.0 U | 5.0 U | 21.0 U | 5.0 U | 5.0 U | 5.0 U | 5.0 U | 5.0 U | 5.0 U |
| 1,3-dichloropropane | 42.0 U | 21.0 U | 5.0 U | 42.0 U | 5.0 U | 5.0 U | 5.0 U | 21.0 U | 5.0 U | 5.0 U | 21.0 U | 5.0 U | 5.0 U | 21.0 U | 5.0 U | 5.0 U | 5.0 U | 5.0 U | 5.0 U | 5.0 U |
| dibromochloromethane | 42.0 U | 21.0 U | 5.0 U | 42.0 U | 5.0 U | 5.0 U | 5.0 U | 21.0 U | 5.0 U | 5.0 U | 21.0 U | 5.0 U | 5.0 U | 21.0 U | 5.0 U | 5.0 U | 5.0 U | 5.0 U | 5.0 U | 5.0 U |
| 1,2-dibromoethane | 42.0 U | 21.0 U | 5.0 U | 42.0 U | 5.0 U | 5.0 U | 5.0 U | 21.0 U | 5.0 U | 5.0 U | 21.0 U | 5.0 U | 5.0 U | 21.0 U | 5.0 U | 5.0 U | 5.0 U | 5.0 U | 5.0 U | 5.0 U |
| chlorobenzene | 716 D | 175 D | 120 | 83.7 D | 34.1 | 25.3 | 12.2 | 124 D | 67.0 | 23.2 | 453 D | 38.8 | 30.7 | 592 D | 643 D | 490 D | 292 D | 303 D | 247 D | |
| 1,1,1,2-tetrachloroethane | 42.0 U | 21.0 U | 5.0 U | 42.0 U | 5.0 U | 5.0 U | 5.0 U | 21.0 U | 5.0 U | 5.0 U | 21.0 U | 5.0 U | 5.0 U | 21.0 U | 5.0 U | 5.0 U | 5.0 U | 5.0 U | 5.0 U | 5.0 U |
| ethylbenzene | 42.0 U | 21.0 U | 5.0 U | 42.0 U | 5.0 U | 5.0 U | 5.0 U | 21.0 U | 5.0 U | 5.0 U | 21.0 U | 5.0 U | 5.0 U | 21.0 U | 5.0 U | 0.7 J | 5.0 U | 5.0 U | 5.0 U | 5.0 U |
| xylene (m/p) | 84.0 U | 42.0 U | 0.9 J | 84.0 U | 10.0 U | 10.0 U | 10.0 U | 42.0 U | 10.0 U | 10.0 U | 3.2 JD | 10.0 U | 10.0 U | 42.0 U | 10.0 U | 5.0 U | 1.0 J | 0.6 J | 5.0 U | 5.0 U |
| o-xylene | 8.57 JD | 21.0 U | 0.7 J | 42.0 U | 5.0 U | 5.0 U | 5.0 U | 21.0 U | 5.0 U | 5.0 U | 2.5 JD | 5.0 U | 5.0 U | 21.0 U | 5.0 U | 1.4 J | 0.8 J | 5.0 U | 5.0 U | 5.0 U |
| styrene | 42.0 U | 21.0 U | 5.0 U | 42.0 U | 5.0 U | 5.0 U | 5.0 U | 21.0 U | 5.0 U | 5.0 U | 21.0 U | 5.0 U | 5.0 U | 21.0 U | 5.0 U | 5.0 U | 5.0 U | 5.0 U | 5.0 U | 5.0 U |
| bromoform | 42.0 U | 21.0 U | 5.0 U | 42.0 U | 5.0 U | 5.0 U | 5.0 U | 21.0 U | 5.0 U | 5.0 U | 21.0 U | 5.0 U | 5.0 U | 21.0 U | 5.0 U | 5.0 U | 5.0 U | 5.0 U | 5.0 U | 5.0 U |
| isopropyl benzene (cumene) | 42.0 U | 21.0 U | 5.0 U | 42.0 U | 5.0 U | 5.0 U | 5.0 U | 21.0 U | 5.0 U | 5.0 U | 21.0 U | 5.0 U | 5.0 U | 21.0 U | 5.0 U | 1.6 J | 1.61 J | 1.2 J | 1.0 J | 5.0 U |
| bromobenzene | 42.0 U | 21.0 U | 5.0 U | 42.0 U | 5.0 U | 5.0 U | 5.0 U | 21.0 U | 5.0 U | 5.0 U | 21.0 U | 5.0 U | 5.0 U | 21.0 U | 5.0 U | 5.0 U | 5.0 U | 5.0 U | 5.0 U | 5.0 U |
| 1,1,1,2-tetrachloroethane | 42.0 U | 21.0 U | 5.0 U | 42.0 U | 5.0 U | 5.0 U | 5.0 U | 21.0 U | 5.0 U | 5.0 U | 21.0 U | 5.0 U | 5.0 U | 21.0 U | 5.0 U | 5.0 U | 5.0 U | 5.0 U | 5.0 U | 5.0 U |
| 1,2,3-trichloropropane | 42.0 U | 21.0 U | 5.0 U | 42.0 U | 5.0 U | 5.0 U | 5.0 U | 21.0 U | 5.0 U | 5.0 U | 21.0 U | 5.0 U | 5.0 U | 21.0 U | 5.0 U | 5.0 U | 5.0 U | 5.0 U | 5.0 U | 5.0 U |
| n-propyl benzene | 5.80 JD | 21.0 U | 5.0 U | 42.0 U | 5.0 U | 5.0 U | 5.0 U | 21.0 U | 5.0 U | 5.0 U | 21.0 U | 5.0 U | 5.0 U | 21.0 U | 5.0 U | 1.3 J | 1.20 J | 1.0 J | 5.0 U | 5.0 U |
| 2-chlorotoluene | 42.0 U | 21.0 U | 5.0 U | 42.0 U | 5.0 U | 5.0 U | 5.0 U | 21.0 U | 5.0 U | 5.0 U | 21.0 U | 5.0 U | 5.0 U | 21.0 U | 5.0 U | 5.0 U | 5.0 U | 5.0 U | 5.0 U | 5.0 U |
| 4-chlorotoluene | 42.0 U | 21.0 U | 5.0 U | 42.0 U | 5.0 U | 5.0 U | 5.0 U | 21.0 U | 5.0 U | 5.0 U | 21.0 U | 5.0 U | 5.0 U | 21.0 U | 5.0 U | 5.0 U | 5.0 U | 5.0 U | 5.0 U | 5.0 U |
| 1,3,5-trimethylbenzene | 14.7 JD | 21.0 U | 0.7 J | 42.0 U | 5.0 U | 5.0 U | 5.0 U | 21.0 U | 5.0 U | 5.0 U | 21.0 U | 5.0 U | 5.0 U | 21.0 U | 5.0 U | 0.7 J | 5.0 U | 5.0 U | 0.9 J | 5.0 U |
| tert-butylbenzene | 42.0 U | 21.0 U | 5.0 U | 42.0 U | 5.0 U | 5.0 U | 5.0 U | 21.0 U | 5.0 U | 5.0 U | 21.0 U | 5.0 U | 5.0 U | 21.0 U | 5.0 U | 5.0 U | 5.0 U | 5.0 U | 5.0 U | 5.0 U |
| 1,2,4-trimethylbenzene | 48.7 D | 21.0 U | 5.0 U | 42.0 U | 5.0 U | 5.0 U | 5.0 U | 21.0 U | 5.0 U | 5.0 U | 5.0 JD | 5.0 U | 5.0 U | 2.4 JD | 0.8 J | 5.0 U | 0.6 J | 5.0 U | 5.0 U | 5.0 U |
| sec-butylbenzene | 42.0 U | 21.0 U | 5.0 U | 42.0 U | 5.0 U | 5.0 U | 5.0 U | 21.0 U | 5.0 U | 5.0 U | 21.0 U | 5.0 U | 5.0 U | 21.0 U | 5.0 U | 1.2 J | 1.20 J | 1.0 J | 0.8 J | 5.0 U |
| 1,3-dichlorobenzene | 16.3 JD | 2.6 JD | 1.2 J | 42.0 U | 0.8 J | 5.0 U | 5.0 U | 2.1 JD | 1.0 J | 5.0 U | 5.3 JD | 0.5 J | 5.0 U | 5.5 JD | 6.9 | 7.66 | 4.5 J | 4.0 J | 4.58 J | |
| 4-isopropyltoluene | 42.0 U | 21.0 U | 5.0 U | 42.0 U | 5.0 U | 5.0 U | 5.0 U | 21.0 U | 5.0 U | 5.0 U | 21.0 U | 5.0 U | 5.0 U | 21.0 U | 5.0 U | 5.0 U | 5.0 U | 5.0 U | 5.0 U | 5.0 U |
| 1,4-dichlorobenzene | 165 D | 18.9 JD | 13.1 | 42.0 U | 5.8 | 5.4 | 3.03 J | 17.9 JD | 9.7 | 5.09 | 48.3 D | 3.8 J | 3.61 J | 33.3 D | 38.1 | 40.5 | 31.3 | 31.4 | 29.0 | |
| 1,2-dichlorobenzene | 1050 D | 59.6 D | 50.8 | 36.5 JD | 13.5 | 14.9 | 8.32 | 54.0 D | 26.7 | 14.5 | 199 D | 3.8 J | 3.98 J | 47.2 D | 47.7 | 30.7 | 72.6 | 51.9 | 38.2 | |
| n-butylbenzene | 42.0 U | 21.0 U | 5.0 U | 42.0 U | 5.0 U | 5.0 U | 5.0 U | 21.0 U | 5.0 U | 5.0 U | | | | | | | | | | |

APPENDIX D.1: GROUNDWATER ANALYTICAL DATA SUMMARY (VOCs)

| Sample ID | SMLS2-3 | SMLS2-3 | SMLS2-3 | SMLS2-4 | SMLS2-4 | SMLS2-4 | SMLS2-5 | SMLS2-5 | SMLS2-5 | SMLS2-6 | SMLS2-7 | SMLS3-1 | SMLS3-1 | SMLS3-2 | SMLS3-2 | SMLS3-3 | SMLS3-3 | SMLS3-4 |
|-----------------------------|----------------|---------------|----------------|--------------|--------------|---------------|--------------|--------------|---------------|--------------|--------------|--------------|--------------|--------------|--------------|--------------|--------------|--------------|
| Sampling Date | 3/24/2015 | 12/7/2015 | 8/3/2016 | 3/24/2015 | 12/7/2015 | 8/3/2016 | 3/25/2015 | 12/7/2015 | 8/3/2016 | 3/25/2015 | 12/7/2015 | 3/25/2015 | 12/7/2015 | 3/25/2015 | 12/7/2015 | 3/25/2015 | 12/7/2015 | 3/25/2015 |
| VOCs (GC/MS) | µg/L | µg/L | µg/L | µg/L | µg/L | µg/L | µg/L | µg/L | µg/L | µg/L | µg/L | µg/L | µg/L | µg/L | µg/L | µg/L | µg/L | µg/L |
| dichlorodifluoromethane | 21.0 U | 5.0 U | 42.0 U | 5.0 U | 5.0 U | 5.0 U | 5.0 U | 5.0 U | 5.0 U | 5.0 U | 5.0 U | 5.0 U | 5.0 U | 5.0 U | 5.0 U | 5.0 U | 5.0 U | 5.0 U |
| chloromethane | 21.0 U | 66.1 | 42.0 U | 5.0 U | 13.7 | 5.0 U | 5.0 U | 5.0 U | 3.0 J | 5.0 U | 5.0 U | 5.0 U | 5.0 U | 5.0 U | 5.0 U | 5.0 U | 5.0 U | 5.0 U |
| vinyl chloride | 2400 D | 3400 D | 2150 D | 578 D | 669 D | 234 D | 28.6 | 173 | 3.94 J | 5.0 U | 17.3 | 36.6 | 315 D | 309 D | 164 | 44.9 | 228 | 1.2 J |
| bromomethane | 21.0 U | 5.0 U | 42.0 U | 5.0 U | 5.0 U | 5.0 U | 5.0 U | 5.0 U | 5.0 U | 5.0 U | 5.0 U | 5.0 U | 5.0 U | 5.0 U | 5.0 U | 5.0 U | 5.0 U | 5.0 U |
| chloroethane | 21.0 U | 5.0 U | 42.0 U | 5.0 U | 5.0 U | 5.0 U | 5.0 U | 5.0 U | 5.0 U | 5.0 U | 5.0 U | 5.0 U | 5.0 U | 5.0 U | 5.0 U | 5.0 U | 5.0 U | 5.0 U |
| trichlorofluoromethane | 21.0 U | 5.0 U | 42.0 U | 5.0 U | 5.0 U | 5.0 U | 5.0 U | 5.0 U | 5.0 U | 5.0 U | 5.0 U | 5.0 U | 5.0 U | 5.0 U | 5.0 U | 5.0 U | 5.0 U | 5.0 U |
| 1,1-dichloroethylene | 6.0 JD | 8.0 | 42.0 U | 1.0 J | 5.0 U | 2.0 J | 5.0 U | 5.0 U | 5.0 U | 5.0 U | 5.0 U | 5.0 U | 5.0 U | 5.0 U | 5.0 U | 5.0 U | 5.0 U | 1.9 J |
| methylene chloride | 21.0 U | 5.0 U | 42.0 U | 5.0 U | 5.0 U | 5.0 U | 5.0 U | 5.0 U | 5.0 U | 5.0 U | 5.0 U | 5.0 U | 5.0 U | 5.0 U | 5.0 U | 5.0 U | 5.0 U | 5.0 U |
| trans-1,2-dichloroethylene | 22.0 D | 23.7 | 13.2 JD | 2.6 J | 1.7 J | 5.0 U | 1.2 J | 1.1 J | 5.0 U | 5.0 U | 0.5 J | 2.1 J | 10.6 | 14.5 | 7.0 | 2.5 J | 1.0 J | 5.0 U |
| 1,1-dichloroethane | 21.0 U | 2.3 J | 42 U | 0.5 J | 2.9 J | 1.13 J | 5.0 U | 2.4 J | 2.10 J | 5.0 U | 5.0 U | 5.0 U | 0.6 J | 5.0 U | 5.0 U | 1.7 J | 5.0 U | 2.4 J |
| 2,2-dichloropropane | 21.0 U | 5.0 U | 42 U | 5.0 U | 5.0 U | 5.0 U | 5.0 U | 5.0 U | 5.0 U | 5.0 U | 5.0 U | 5.0 U | 5.0 U | 5.0 U | 5.0 U | 5.0 U | 5.0 U | 5.0 U |
| cis 1,2- dichloroethylene | 1800 D | 4090 D | 4050 D | 556 D | 267 D | 96.9 | 30.6 | 41.9 | 2.76 J | 4.5 J | 18.3 | 12.0 | 107 | 121 | 42.1 | 19.8 | 80.9 | 5.0 U |
| bromochloromethane | 21.0 U | 5.0 U | 42.0 U | 5.0 U | 5.0 U | 5.0 U | 5.0 U | 5.0 U | 5.0 U | 5.0 U | 5.0 U | 5.0 U | 5.0 U | 5.0 U | 5.0 U | 5.0 U | 5.0 U | 5.0 U |
| chloroform | 21.0 U | 5.0 U | 42.0 U | 5.0 U | 5.0 U | 5.0 U | 5.0 U | 5.0 U | 5.0 U | 5.0 U | 5.0 U | 5.0 U | 5.0 U | 5.0 U | 5.0 U | 5.0 U | 5.0 U | 5.0 U |
| 1,1,1-trichloroethane | 21.0 U | 5.0 U | 42.0 U | 5.0 U | 5.0 U | 5.0 U | 5.0 U | 5.0 U | 5.0 U | 5.0 U | 5.0 U | 5.0 U | 5.0 U | 5.0 U | 5.0 U | 5.0 U | 5.0 U | 5.0 U |
| carbon tetrachloride | 21.0 U | 5.0 U | 42.0 U | 5.0 U | 5.0 U | 5.0 U | 5.0 U | 5.0 U | 5.0 U | 5.0 U | 5.0 U | 5.0 U | 5.0 U | 5.0 U | 5.0 U | 5.0 U | 5.0 U | 5.0 U |
| 1,1-dichloropropene | 21.0 U | 5.0 U | 42.0 U | 5.0 U | 5.0 U | 5.0 U | 5.0 U | 5.0 U | 5.0 U | 5.0 U | 5.0 U | 5.0 U | 5.0 U | 5.0 U | 5.0 U | 5.0 U | 5.0 U | 5.0 U |
| benzene | 21.0 U | 5.0 U | 42.0 U | 5.0 U | 5.0 U | 5.0 U | 5.0 U | 5.0 U | 5.0 U | 5.0 U | 5.0 U | 5.0 U | 0.6 J | 5.0 U | 5.0 U | 5.0 U | 5.0 U | 5.0 U |
| 1,2-dichloroethane | 21.0 U | 5.0 U | 42.0 U | 5.0 U | 5.0 U | 5.0 U | 5.0 U | 5.0 U | 5.0 U | 5.0 U | 5.0 U | 5.0 U | 5.0 U | 5.0 U | 5.0 U | 5.0 U | 5.0 U | 5.0 U |
| trichloroethylene | 70.9 D | 146 | 294 D | 1.0 J | 1.3 J | 1.02 J | 0.6 J | 1.0 J | 5.0 U | 5.0 U | 0.7 J | 5.0 U | 5.0 U | 0.9 J | 5.0 U | 5.0 U | 5.0 U | 5.0 U |
| 1,2-dichloropropane | 21.0 U | 5.0 U | 42.0 U | 5.0 U | 5.0 U | 5.0 U | 5.0 U | 5.0 U | 5.0 U | 5.0 U | 5.0 U | 5.0 U | 5.0 U | 5.0 U | 5.0 U | 5.0 U | 5.0 U | 5.0 U |
| dibromomethane | 21.0 U | 5.0 U | 42.0 U | 5.0 U | 5.0 U | 5.0 U | 5.0 U | 5.0 U | 5.0 U | 5.0 U | 5.0 U | 5.0 U | 5.0 U | 5.0 U | 5.0 U | 5.0 U | 5.0 U | 5.0 U |
| bromodichloromethane | 21.0 U | 5.0 U | 42.0 U | 5.0 U | 5.0 U | 5.0 U | 5.0 U | 5.0 U | 5.0 U | 5.0 U | 5.0 U | 5.0 U | 5.0 U | 5.0 U | 5.0 U | 5.0 U | 5.0 U | 5.0 U |
| cis-1,3-dichloropropene | 21.0 U | 5.0 U | 42.0 U | 5.0 U | 5.0 U | 5.0 U | 5.0 U | 5.0 U | 5.0 U | 5.0 U | 5.0 U | 5.0 U | 5.0 U | 5.0 U | 5.0 U | 5.0 U | 5.0 U | 5.0 U |
| toluene | 21.0 U | 1.0 J | 42.0 U | 5.0 U | 5.0 U | 5.0 U | 5.0 U | 5.0 U | 5.0 U | 5.0 U | 5.0 U | 0.6 J | 5.0 U | 0.7 J | 5.0 U | 5.0 U | 5.0 U | 5.0 U |
| trans-1,3-dichloropropene | 21.0 U | 5.0 U | 42.0 U | 5.0 U | 5.0 U | 5.0 U | 5.0 U | 5.0 U | 5.0 U | 5.0 U | 5.0 U | 5.0 U | 5.0 U | 5.0 U | 5.0 U | 5.0 U | 5.0 U | 5.0 U |
| 1,1,2-trichloroethane | 21.0 U | 5.0 U | 42.0 U | 5.0 U | 5.0 U | 5.0 U | 5.0 U | 5.0 U | 5.0 U | 5.0 U | 5.0 U | 5.0 U | 5.0 U | 5.0 U | 5.0 U | 5.0 U | 5.0 U | 5.0 U |
| tetrachloroethylene | 21.0 U | 5.0 U | 42.0 U | 5.0 U | 5.0 U | 5.0 U | 5.0 U | 5.0 U | 5.0 U | 5.0 U | 5.0 U | 5.0 U | 5.0 U | 5.0 U | 5.0 U | 5.0 U | 5.0 U | 5.0 U |
| 1,3-dichloropropane | 21.0 U | 5.0 U | 42.0 U | 5.0 U | 5.0 U | 5.0 U | 5.0 U | 5.0 U | 5.0 U | 5.0 U | 5.0 U | 5.0 U | 5.0 U | 5.0 U | 5.0 U | 5.0 U | 5.0 U | 5.0 U |
| dibromochloromethane | 21.0 U | 5.0 U | 42.0 U | 5.0 U | 5.0 U | 5.0 U | 5.0 U | 5.0 U | 5.0 U | 5.0 U | 5.0 U | 5.0 U | 5.0 U | 5.0 U | 5.0 U | 5.0 U | 5.0 U | 5.0 U |
| 1,2-dibromoethane | 21.0 U | 5.0 U | 42.0 U | 5.0 U | 5.0 U | 5.0 U | 5.0 U | 5.0 U | 5.0 U | 5.0 U | 5.0 U | 5.0 U | 5.0 U | 5.0 U | 5.0 U | 5.0 U | 5.0 U | 5.0 U |
| chlorobenzene | 81.5 D | 66.6 | 68.7 D | 53.8 | 39.1 | 15.0 | 33.0 | 28.0 | 11.2 | 32.4 | 51.7 | 363 D | 155 | 202 | 142 | 462 D | 76.1 | 35.5 |
| 1,1,1,2-tetrachloroethane | 21.0 U | 5.0 U | 42.0 U | 5.0 U | 5.0 U | 5.0 U | 5.0 U | 5.0 U | 5.0 U | 5.0 U | 5.0 U | 5.0 U | 5.0 U | 5.0 U | 5.0 U | 5.0 U | 5.0 U | 5.0 U |
| ethylbenzene | 21.0 U | 0.6 J | 42.0 U | 5.0 U | 5.0 U | 5.0 U | 5.0 U | 5.0 U | 5.0 U | 5.0 U | 5.0 U | 5.0 U | 5.0 U | 5.0 U | 5.0 U | 5.0 U | 5.0 U | 5.0 U |
| xylene (m/p) | 42.0 U | 10.0 U | 42.0 U | 0.6 J | 10.0 U | 5.0 U | 10.0 U | 10.0 U | 5.0 U | 10.0 U | 10.0 U | 10.0 U | 10.0 U | 10.0 U | 10.0 U | 10.0 U | 10.0 U | 10.0 U |
| o-xylene | 21.0 U | 0.7 J | 42.0 U | 5.0 U | 5.0 U | 5.0 U | 5.0 U | 5.0 U | 5.0 U | 5.0 U | 5.0 U | 5.0 U | 5.0 U | 5.0 U | 5.0 U | 5.0 U | 5.0 U | 5.0 U |
| styrene | 21.0 U | 5.0 U | 42.0 U | 5.0 U | 5.0 U | 5.0 U | 5.0 U | 5.0 U | 5.0 U | 5.0 U | 5.0 U | 5.0 U | 5.0 U | 5.0 U | 5.0 U | 5.0 U | 5.0 U | 5.0 U |
| bromoform | 21.0 U | 5.0 U | 42.0 U | 5.0 U | 5.0 U | 5.0 U | 5.0 U | 5.0 U | 5.0 U | 5.0 U | 5.0 U | 5.0 U | 5.0 U | 5.0 U | 5.0 U | 5.0 U | 5.0 U | 5.0 U |
| isopropyl benzene (cumene) | 21.0 U | 5.0 U | 42.0 U | 5.0 U | 5.0 U | 5.0 U | 5.0 U | 5.0 U | 5.0 U | 5.0 U | 5.0 U | 0.9 J | 5.0 U | 5.0 U | 5.0 U | 5.0 U | 5.0 U | 5.0 U |
| bromobenzene | 21.0 U | 5.0 U | 42.0 U | 5.0 U | 5.0 U | 5.0 U | 5.0 U | 5.0 U | 5.0 U | 5.0 U | 5.0 U | 5.0 U | 5.0 U | 5.0 U | 5.0 U | 5.0 U | 5.0 U | 5.0 U |
| 1,1,2,2-tetrachloroethane | 21.0 U | 5.0 U | 42.0 U | 5.0 U | 5.0 U | 5.0 U | 5.0 U | 5.0 U | 5.0 U | 5.0 U | 5.0 U | 5.0 U | 5.0 U | 5.0 U | 5.0 U | 5.0 U | 5.0 U | 5.0 U |
| 1,2,3-trichloropropane | 21.0 U | 5.0 U | 42.0 U | 5.0 U | 5.0 U | 5.0 U | 5.0 U | 5.0 U | 5.0 U | 5.0 U | 5.0 U | 5.0 U | 5.0 U | 5.0 U | 5.0 U | 5.0 U | 5.0 U | 5.0 U |
| n-propyl benzene | 21.0 U | 5.0 U | 42.0 U | 5.0 U | 5.0 U | 5.0 U | 5.0 U | 5.0 U | 5.0 U | 5.0 U | 5.0 U | 5.0 U | 5.0 U | 5.0 U | 5.0 U | 5.0 U | 5.0 U | 5.0 U |
| 2-chlorotoluene | 21.0 U | 5.0 U | 42.0 U | 5.0 U | 5.0 U | 5.0 U | 5.0 U | 5.0 U | 5.0 U | 5.0 U | 5.0 U | 5.0 U | 5.0 U | 5.0 U | 5.0 U | 5.0 U | 5.0 U | 5.0 U |
| 4-chlorotoluene | 21.0 U | 5.0 U | 42.0 U | 5.0 U | 5.0 U | 5.0 U | 5.0 U | 5.0 U | 5.0 U | 5.0 U | 5.0 U | 5.0 U | 5.0 U | 5.0 U | 5.0 U | 5.0 U | 5.0 U | 5.0 U |
| 1,3,5-trimethylbenzene | 21.0 U | 5.0 U | 42.0 U | 5.0 U | 5.0 U | 5.0 U | 5.0 U | 5.0 U | 5.0 U | 5.0 U | 5.0 U | 5.0 U | 5.0 U | 5.0 U | 5.0 U | 5.0 U | 5.0 U | 5.0 U |
| tert-butylbenzene | 21.0 U | 5.0 U | 42.0 U | 5.0 U | 5.0 U | 5.0 U | 5.0 U | 5.0 U | 5.0 U | 5.0 U | 5.0 U | 5.0 U | 5.0 U | 5.0 U | 5.0 U | 5.0 U | 5.0 U | 5.0 U |
| 1,2,4-trimethylbenzene | 21.0 U | 5.0 U | 42.0 U | 5.0 U | 5.0 U | 5.0 U | 5.0 U | 5.0 U | 5.0 U | 5.0 U | 5.0 U | 0.5 J | 5.0 U | 5.0 U | 5.0 U | 5.0 U | 5.0 U | 5.0 U |
| sec-butylbenzene | 21.0 U | 5.0 U | 42.0 U | 5.0 U | 5.0 U | 5.0 U | 5.0 U | 5.0 U | 5.0 U | 5.0 U | 5.0 U | 0.8 J | 5.0 U | 0.6 J | 5.0 U | 1.1 J | 5.0 U | 5.0 U |
| 1,3-dichlorobenzene | 2.7 JD | 1.7 J | 42.0 U | 1.2 J | 5.0 U | 5.0 U | 0.9 J | 0.7 J | 5.0 U | 0.6 J | 0.7 J | 3.3 J | 1.1 J | 2.1 J | 1.3 J | 5.1 | 0.8 J | 0.6 J |
| 4-isopropyltoluene | 21.0 U | 5.0 U | 42.0 U | 5.0 U | 5.0 U | 5.0 U | 5.0 U | 5.0 U | 5.0 U | 5.0 U | 5.0 U | 5.0 U | 5.0 U | 5.0 U | 5.0 U | 5.0 U | 5.0 U | 5.0 U |
| 1,4-dichlorobenzene | 20.0 JD | 16.0 | 20.4 JD | 6.9 | 5.2 | 2.66 J | 5.6 | 5.2 | 3.07 J | 4.2 J | 4.6 J | 18.4 | 8.7 | 11.1 | 9.4 | 24.6 | 6.2 | 3.8 J |
| 1,2-dichlorobenzene | 116 D | 92.7 | 127 D | 21.0 | 18.3 | 7.57 | 11.2 | 14.3 | 7.78 | 5.1 | 4.5 J | 15.7 | 17.4 | 15.4 | 18.1 | 10.8 | 9.5 | 5.1 |
| n-butylbenzene | 21.0 U | 5.0 U | 42.0 U | 5.0 U | 5.0 U | 5.0 U | 5.0 U | 5.0 U | 5.0 U | 5.0 U | 5.0 U | 5.0 U | 5.0 U | 5.0 U | 5.0 U | 5.0 U | 5.0 U | 5.0 U |
| 1,2-dibromo-3-chloropropane | 21.0 U | 5.0 U | 42.0 U | 5.0 U | 5.0 U | 5.0 U | 5.0 U | 5.0 U | 5.0 U | 5.0 U | 5.0 U | 5.0 U | 5.0 U | 5.0 U | 5.0 U | 5.0 U | 5.0 U | 5.0 U |
| 1,2,4-trichlorobenzene | 21.0 U | 5.0 U | 42.0 U | 5.0 U | 5.0 U | 5.0 U | 5.0 U | 5.0 U | 5.0 U | 5.0 U | 5.0 U | 5.0 U | 5.0 U | 5.0 U | 5.0 U | 5.0 U | 5.0 U | 5.0 U |
| hexachlorobutadiene | 21.0 U | 5.0 U | 42.0 U | 5.0 U | 5.0 U | 5.0 U | 0.7 J | 5.0 U | 5.0 U | 5.0 U | 5.0 U | 5.0 U | 5.0 U | 5.0 U | 5.0 U | 5.0 U | 5.0 U | 5.0 U |
| naphthalene | 21.0 U | 5.0 U | 42.0 U | 1.1 J | 5.0 U | 5.0 U | 1.1 J | 5.0 U | 5.0 U | 5.0 U | 5.0 U | 5.0 U | 5.0 U | 5.0 U | 5.0 U | 5.0 U | 5.0 U | 5.0 U |
| 1,2,3-trichlorobenzene | 21.0 U | 5.0 U | 42.0 U | 0.8 J | 5.0 U | 5.0 U | 1.1 J | 5.0 U | 5.0 U | 5.0 U | 5.0 U | 5.0 U | 5.0 U | 5.0 U | 5.0 U | 5.0 U | 5.0 U | 5.0 U |
| Methyl tertiary butyl ether | 21.0 U | 5.0 U | 42.0 U | 5.0 U | 5.0 U | 5.0 U | 5.0 U | 5.0 U | 5.0 U | 5.0 U | 5.0 U | 5.0 U | 5.0 U | 5.0 U | 5.0 U | 5.0 U | 5.0 U | 5.0 U |
| Acetone | 42.0 U | 10.0 U | 84 | | | | | | | | | | | | | | | |

APPENDIX D.1: GROUNDWATER ANALYTICAL DATA SUMMARY (VOCs)

| Sample ID | SMLS3-4 | SMLS3-5 | SMLS3-6 | SMLS3-7 | SMLS4-1 | SMLS4-1 | SMLS4-1 | SMLS4-2 | SMLS4-2 | SMLS4-2 | SMLS4-3 | SMLS4-3 | SMLS4-3 | SMLS4-4 | SMLS4-4 | SMLS4-4 | SMLS4-5 | SMLS4-5 |
|-----------------------------|--------------|--------------|--------------|--------------|---------------|---------------|---------------|---------------|----------------|----------------|---------------|--------------|----------------|---------------|----------------|----------------|---------------|--------------|
| Sampling Date | 12/7/2015 | 3/25/2015 | 3/25/2015 | 3/25/2015 | 3/26/2015 | 12/7/2015 | 8/2/2016 | 3/26/2015 | 12/7/2015 | 8/2/2016 | 3/26/2015 | 12/7/2015 | 8/2/2016 | 3/26/2015 | 12/7/2015 | 8/2/2016 | 3/26/2015 | 12/7/2015 |
| VOCs (GC/MS) | µg/L | µg/L | µg/L | µg/L | µg/L | µg/L | µg/L | µg/L | µg/L | µg/L | µg/L | µg/L | µg/L | µg/L | µg/L | µg/L | µg/L | µg/L |
| dichlorodifluoromethane | 5.0 U | 5.0 U | 5.0 U | 5.0 U | 5.0 U | 5.0 U | 5.0 U | 5.0 U | 42.0 U | 42.0 U | 5.0 U | 5.0 U | 42.0 U | 5.0 U | 42.0 U | 42.0 U | 5.0 U | 5.0 U |
| chloromethane | 2.8 J | 5.0 U | 5.0 U | 5.0 U | 5.0 U | 2.3 J | 5.0 U | 5.0 U | 153 D | 29.1 JD | 5.0 U | 0.7 J | 42.0 U | 5.0 U | 184 D | 42.0 U | 5.0 U | 2.0 J |
| vinyl chloride | 501 D | 3.1 J | 0.7 J | 5.0 U | 1020 D | 3830 D | 985 D | 2670 D | 8130 D | 9910 D | 471 D | 706 D | 8930 D | 6260 D | 9440 D | 11200 D | 950 D | 59.2 |
| bromomethane | 5.0 U | 5.0 U | 5.0 U | 5.0 U | 5.0 U | 5.0 U | 5.0 U | 5.0 U | 42.0 U | 42.0 U | 5.0 U | 5.0 U | 42.0 U | 5.0 U | 42.0 U | 42.0 U | 5.0 U | 5.0 U |
| chloroethane | 5.0 U | 5.0 U | 5.0 U | 5.0 U | 5.0 U | 5.0 U | 5.0 U | 5.0 U | 42.0 U | 42.0 U | 5.0 U | 5.0 U | 42.0 U | 5.0 U | 42.0 U | 42.0 U | 5.0 U | 5.0 U |
| trichlorofluoromethane | 5.0 U | 5.0 U | 5.0 U | 5.0 U | 5.0 U | 5.0 U | 5.0 U | 5.0 U | 42.0 U | 42.0 U | 5.0 U | 5.0 U | 42.0 U | 5.0 U | 42.0 U | 42.0 U | 5.0 U | 5.0 U |
| 1,1-dichloroethylene | 9.4 | 5.0 U | 5.0 U | 5.0 U | 1.00 J | 3.9 J | 5.0 U | 18.7 | 50.8 D | 65.4 D | 0.83 J | 0.7 J | 28.9 JD | 5.42 | 8.2 JD | 20.2 JD | 5.0 U | 5.0 U |
| methylene chloride | 5.0 U | 5.0 U | 5.0 U | 5.0 U | 5.0 U | 5.0 U | 5.0 U | 5.0 U | 42.0 U | 42.0 U | 5.0 U | 5.0 U | 42.0 U | 5.0 U | 42.0 U | 42.0 U | 5.0 U | 5.0 U |
| trans-1,2-dichloroethylene | 5.0 U | 5.0 U | 5.0 U | 5.0 U | 26.2 | 51.6 | 10.2 | 131 | 167 D | 275 D | 8.55 | 18.1 | 53.8 D | 20.0 | 12.8 JD | 33.5 JD | 8.79 | 12.9 |
| 1,1-dichloroethane | 2.7 J | 0.7 J | 0.5 J | 5.0 U | 5.0 U | 5.0 U | 5.0 U | 5.0 U | 42.0 U | 42.0 U | 5.0 U | 5.0 U | 42.0 U | 5.0 U | 42.0 U | 42.0 U | 5.0 U | 5.0 U |
| 2,2-dichloropropane | 5.0 U | 5.0 U | 5.0 U | 5.0 U | 5.0 U | 5.0 U | 5.0 U | 5.0 U | 42.0 U | 42.0 U | 5.0 U | 5.0 U | 42.0 U | 5.0 U | 42.0 U | 42.0 U | 5.0 U | 5.0 U |
| cis 1,2- dichloroethylene | 314 D | 0.6 J | 5.0 U | 5.0 U | 607 D | 2210 D | 1730 D | 6290 D | 20000 D | 28000 D | 296 | 239 D | 12500 D | 2420 D | 3990 D | 12800 D | 141 | 13.5 |
| bromochloromethane | 5.0 U | 5.0 U | 5.0 U | 5.0 U | 5.0 U | 5.0 U | 5.0 U | 5.0 U | 42.0 U | 42.0 U | 5.0 U | 5.0 U | 42.0 U | 5.0 U | 42.0 U | 42.0 U | 5.0 U | 5.0 U |
| chloroform | 5.0 U | 5.0 U | 5.0 U | 5.0 U | 5.0 U | 5.0 U | 5.0 U | 5.0 U | 42.0 U | 42.0 U | 5.0 U | 5.0 U | 42.0 U | 5.0 U | 42.0 U | 42.0 U | 5.0 U | 5.0 U |
| 1,1,1-trichloroethane | 5.0 U | 5.0 U | 5.0 U | 5.0 U | 5.0 U | 5.0 U | 5.0 U | 5.0 U | 42.0 U | 42.0 U | 5.0 U | 5.0 U | 42.0 U | 5.0 U | 42.0 U | 42.0 U | 5.0 U | 5.0 U |
| carbon tetrachloride | 5.0 U | 5.0 U | 5.0 U | 5.0 U | 5.0 U | 5.0 U | 5.0 U | 5.0 U | 42.0 U | 42.0 U | 5.0 U | 5.0 U | 42.0 U | 5.0 U | 42.0 U | 42.0 U | 5.0 U | 5.0 U |
| 1,1-dichloropropene | 5.0 U | 5.0 U | 5.0 U | 5.0 U | 5.0 U | 5.0 U | 5.0 U | 5.0 U | 42.0 U | 42.0 U | 5.0 U | 5.0 U | 42.0 U | 5.0 U | 42.0 U | 42.0 U | 5.0 U | 5.0 U |
| benzene | 5.0 U | 5.0 U | 5.0 U | 5.0 U | 0.5 J | 0.5 J | 5.0 U | 0.75 J | 42.0 U | 42.0 U | 0.88 J | 0.8 J | 42.0 U | 5.0 U | 42.0 U | 42.0 U | 5.0 U | 5.0 U |
| 1,2-dichloroethane | 5.0 U | 5.0 U | 5.0 U | 5.0 U | 5.0 U | 0.6 J | 5.0 U | 5.0 U | 42.0 U | 42.0 U | 5.0 U | 5.0 U | 42.0 U | 1.55 J | 42.0 U | 42.0 U | 5.0 U | 5.0 U |
| trichloroethylene | 5.0 U | 5.0 U | 5.0 U | 5.0 U | 2.2 J | 4.0 J | 3.62 J | 1230 D | 2880 D | 5490 D | 94.2 | 2.2 J | 2840 D | 7.00 | 42.0 U | 42.0 U | 1.96 J | 0.5 J |
| 1,2-dichloropropane | 5.0 U | 5.0 U | 5.0 U | 5.0 U | 5.0 U | 5.0 U | 5.0 U | 5.0 U | 42.0 U | 42.0 U | 5.0 U | 5.0 U | 42.0 U | 5.0 U | 42.0 U | 42.0 U | 5.0 U | 5.0 U |
| dibromomethane | 5.0 U | 5.0 U | 5.0 U | 5.0 U | 5.0 U | 5.0 U | 5.0 U | 5.0 U | 42.0 U | 42.0 U | 5.0 U | 5.0 U | 42.0 U | 5.0 U | 42.0 U | 42.0 U | 5.0 U | 5.0 U |
| bromodichloromethane | 5.0 U | 5.0 U | 5.0 U | 5.0 U | 5.0 U | 5.0 U | 5.0 U | 5.0 U | 42.0 U | 42.0 U | 5.0 U | 5.0 U | 42.0 U | 5.0 U | 42.0 U | 42.0 U | 5.0 U | 5.0 U |
| cis-1,3-dichloropropene | 5.0 U | 5.0 U | 5.0 U | 5.0 U | 5.0 U | 5.0 U | 5.0 U | 5.0 U | 42.0 U | 42.0 U | 5.0 U | 5.0 U | 42.0 U | 5.0 U | 42.0 U | 42.0 U | 5.0 U | 5.0 U |
| toluene | 5.0 U | 5.0 U | 5.0 U | 5.0 U | 3.5 J | 4.4 J | 1.85 J | 5.91 | 6.0 JD | 42.0 U | 4.35 J | 4.1 J | 42.0 U | 3.87 J | 42.0 U | 42.0 U | 2.29 J | 2.0 J |
| trans-1,3-dichloropropene | 5.0 U | 5.0 U | 5.0 U | 5.0 U | 5.0 U | 5.0 U | 5.0 U | 5.0 U | 42.0 U | 42.0 U | 5.0 U | 5.0 U | 42.0 U | 5.0 U | 42.0 U | 42.0 U | 5.0 U | 5.0 U |
| 1,1,2-trichloroethane | 5.0 U | 5.0 U | 5.0 U | 5.0 U | 5.0 U | 5.0 U | 5.0 U | 5.0 U | 42.0 U | 42.0 U | 5.0 U | 5.0 U | 42.0 U | 5.0 U | 42.0 U | 42.0 U | 5.0 U | 5.0 U |
| tetrachloroethylene | 5.0 U | 5.0 U | 5.0 U | 5.0 U | 5.0 U | 5.0 U | 8.30 | 5.0 U | 42.0 U | 42.0 U | 5.0 U | 5.0 U | 42.0 U | 5.0 U | 42.0 U | 42.0 U | 5.0 U | 5.0 U |
| 1,3-dichloropropane | 5.0 U | 5.0 U | 5.0 U | 5.0 U | 5.0 U | 5.0 U | 5.0 U | 5.0 U | 42.0 U | 42.0 U | 5.0 U | 5.0 U | 42.0 U | 5.0 U | 42.0 U | 42.0 U | 5.0 U | 5.0 U |
| dibromochloromethane | 5.0 U | 5.0 U | 5.0 U | 5.0 U | 5.0 U | 5.0 U | 5.0 U | 5.0 U | 42.0 U | 42.0 U | 5.0 U | 5.0 U | 42.0 U | 5.0 U | 42.0 U | 42.0 U | 5.0 U | 5.0 U |
| 1,2-dibromoethane | 5.0 U | 5.0 U | 5.0 U | 5.0 U | 5.0 U | 5.0 U | 5.0 U | 5.0 U | 42.0 U | 42.0 U | 5.0 U | 5.0 U | 42.0 U | 5.0 U | 42.0 U | 42.0 U | 5.0 U | 5.0 U |
| chlorobenzene | 18.7 | 20.2 | 23.7 | 56.7 | 448 D | 420 D | 270 D | 631 D | 511 D | 453 D | 760 D | 544 D | 552 D | 790 D | 391 D | 389 D | 566 D | 203 D |
| 1,1,1,2-tetrachloroethane | 5.0 U | 5.0 U | 5.0 U | 5.0 U | 5.0 U | 5.0 U | 5.0 U | 5.0 U | 42.0 U | 42.0 U | 5.0 U | 5.0 U | 42.0 U | 5.0 U | 42.0 U | 42.0 U | 5.0 U | 5.0 U |
| ethylbenzene | 5.0 U | 5.0 U | 5.0 U | 5.0 U | 0.82 J | 0.8 J | 5.0 U | 1.57 J | 42.0 U | 42.0 U | 1.10 J | 0.9 J | 42.0 U | 1.35 J | 42.0 U | 42.0 U | 0.72 J | 5.0 U |
| xylenes (m/p) | 10.0 U | 10.0 U | 10.0 U | 10.0 U | 1.00 J | 10.0 U | 5.0 U | 1.26 J | 84.0 U | 42.0 U | 0.92 J | 10.0 U | 42.0 U | 3.99 J | 84.0 U | 42.0 U | 1.91 J | 10.0 U |
| o-xylene | 5.0 U | 5.0 U | 5.0 U | 5.0 U | 2.18 J | 2.5 J | 1.05 J | 4.58 J | 42.0 U | 42.0 U | 2.20 J | 1.7 J | 42.0 U | 3.51 J | 42.0 U | 42.0 U | 1.62 J | 0.8 J |
| styrene | 5.0 U | 5.0 U | 5.0 U | 5.0 U | 5.0 U | 5.0 U | 5.0 U | 5.0 U | 42.0 U | 42.0 U | 5.0 U | 5.0 U | 42.0 U | 5.0 U | 42.0 U | 42.0 U | 5.0 U | 5.0 U |
| bromoform | 5.0 U | 5.0 U | 5.0 U | 5.0 U | 5.0 U | 5.0 U | 5.0 U | 5.0 U | 42.0 U | 42.0 U | 5.0 U | 5.0 U | 42.0 U | 5.0 U | 42.0 U | 42.0 U | 5.0 U | 5.0 U |
| isopropyl benzene (cumene) | 5.0 U | 5.0 U | 5.0 U | 5.0 U | 0.99 J | 1.1 J | 5.0 U | 2.52 J | 42.0 U | 42.0 U | 1.81 J | 1.1 J | 42.0 U | 3.19 J | 42.0 U | 42.0 U | 1.64 J | 5.0 U |
| bromobenzene | 5.0 U | 5.0 U | 5.0 U | 5.0 U | 5.0 U | 5.0 U | 5.0 U | 5.0 U | 42.0 U | 42.0 U | 5.0 U | 5.0 U | 42.0 U | 5.0 U | 42.0 U | 42.0 U | 5.0 U | 5.0 U |
| 1,1,2,2-tetrachloroethane | 5.0 U | 5.0 U | 5.0 U | 5.0 U | 5.0 U | 5.0 U | 5.0 U | 5.0 U | 42.0 U | 42.0 U | 5.0 U | 5.0 U | 42.0 U | 5.0 U | 42.0 U | 42.0 U | 5.0 U | 5.0 U |
| 1,2,3-trichloropropane | 5.0 U | 5.0 U | 5.0 U | 5.0 U | 5.0 U | 5.0 U | 5.0 U | 5.0 U | 42.0 U | 42.0 U | 5.0 U | 5.0 U | 42.0 U | 5.0 U | 42.0 U | 42.0 U | 5.0 U | 5.0 U |
| n-propyl benzene | 5.0 U | 5.0 U | 5.0 U | 5.0 U | 5.0 U | 5.0 U | 5.0 U | 5.0 U | 42.0 U | 42.0 U | 5.0 U | 5.0 U | 42.0 U | 4.07 J | 42.0 U | 42.0 U | 1.72 J | 5.0 U |
| 2-chlorotoluene | 5.0 U | 5.0 U | 5.0 U | 5.0 U | 5.0 U | 5.0 U | 5.0 U | 5.0 U | 42.0 U | 42.0 U | 5.0 U | 5.0 U | 42.0 U | 5.0 U | 42.0 U | 42.0 U | 5.0 U | 5.0 U |
| 4-chlorotoluene | 5.0 U | 5.0 U | 5.0 U | 5.0 U | 5.0 U | 5.0 U | 5.0 U | 5.0 U | 42.0 U | 42.0 U | 5.0 U | 5.0 U | 42.0 U | 5.0 U | 42.0 U | 42.0 U | 5.0 U | 5.0 U |
| 1,3,5-trimethylbenzene | 5.0 U | 5.0 U | 5.0 U | 5.0 U | 5.0 U | 5.0 U | 5.0 U | 5.0 U | 42.0 U | 42.0 U | 5.0 U | 5.0 U | 42.0 U | 0.76 J | 42.0 U | 42.0 U | 5.0 U | 5.0 U |
| tert-butylbenzene | 5.0 U | 5.0 U | 5.0 U | 5.0 U | 5.0 U | 5.0 U | 5.0 U | 5.0 U | 42.0 U | 42.0 U | 5.0 U | 5.0 U | 42.0 U | 5.0 U | 42.0 U | 42.0 U | 5.0 U | 5.0 U |
| 1,2,4-trimethylbenzene | 5.0 U | 5.0 U | 5.0 U | 5.0 U | 5.0 U | 5.0 U | 5.0 U | 5.0 U | 42.0 U | 42.0 U | 5.0 U | 5.0 U | 42.0 U | 5.0 U | 42.0 U | 42.0 U | 5.0 U | 5.0 U |
| sec-butylbenzene | 5.0 U | 5.0 U | 5.0 U | 5.0 U | 5.0 U | 5.0 U | 5.0 U | 1.33 J | 42.0 U | 42.0 U | 0.74 J | 5.0 U | 42.0 U | 3.66 J | 42.0 U | 42.0 U | 1.44 J | 5.0 U |
| 1,3-dichlorobenzene | 5.0 U | 5.0 U | 5.0 U | 0.7 J | 3.92 J | 4.1 J | 2.43 J | 9.16 | 42.0 U | 8.57 JD | 5.21 | 3.3 J | 42.0 U | 11.5 | 42.0 U | 42.0 U | 5.64 | 2.5 J |
| 4-isopropyltoluene | 5.0 U | 5.0 U | 5.0 U | 5.0 U | 5.0 U | 5.0 U | 5.0 U | 5.0 U | 42.0 U | 42.0 U | 5.0 U | 5.0 U | 42.0 U | 5.0 U | 42.0 U | 42.0 U | 5.0 U | 5.0 U |
| 1,4-dichlorobenzene | 2.6 J | 3.1 J | 3.2 J | 4.3 J | 31.7 | 36.6 | 23.6 | 75.9 | 70.6 D | 102 D | 53.5 | 41.0 | 83.2 D | 87.0 | 48.2 D | 69.5 D | 47.0 | 25.2 |
| 1,2-dichlorobenzene | 6.5 | 5.4 | 4.4 J | 3.3 J | 84.3 | 120 | 82.6 | 337 JD | 392 D | 682 D | 101 | 82.1 | 464 D | 193 | 134 D | 194 D | 48.3 | 46.4 |
| n-butylbenzene | 5.0 U | 5.0 U | 5.0 U | 5.0 U | 5.0 U | 5.0 U | 5.0 U | 5.0 U | 42.0 U | 42.0 U | 5.0 U | 5.0 U | 42.0 U | 2.38 J | 42.0 U | 42.0 U | 0.79 J | 5.0 U |
| 1,2-dibromo-3-chloropropane | 5.0 U | 5.0 U | 5.0 U | 5.0 U | 5.0 U | 5.0 U | 5.0 U | 5.0 U | 42.0 U | 42.0 U | 5.0 U | 5.0 U | 42.0 U | 5.0 U | 42.0 U | 42.0 U | 5.0 U | 5.0 U |
| 1,2,4-trichlorobenzene | 5.0 U | 5.0 U | 5.0 U | 5.0 U | 5.0 U | 5.0 U | 5.0 U | 5.0 U | 42.0 U | 42.0 U | 5.0 U | 5.0 U | 42.0 U | 5.0 U | 42.0 U | 42.0 U | 5.0 U | 5.0 U |
| hexachlorobutadiene | 5.0 U | 5.0 U | 5.0 U | 5.0 U | 5.0 U | 5.0 U | 5.0 U | 5.0 U | 42.0 U | 42.0 U | 5.0 U | 5.0 U | 42.0 U | 5.0 U | 42.0 U | 42.0 U | 5.0 U | 5.0 U |
| naphthalene | 5.0 U | 5.0 U | 5.0 U | 5.0 U | 0.87 J | 5.0 U | 5.0 U | 0.57 J | 42.0 U | 42.0 U | 5.0 U | 5.0 U | 42.0 | | | | | |

APPENDIX D.1: GROUNDWATER ANALYTICAL DATA SUMMARY (VOCs)

| Sample ID | SMLS6-2 | SMLS6-3 | SMLS6-4 | SMLS6-5 | SMLS6-6 | SMLS6-7 | SMLS7-1 | SMLS7-1 | SMLS7-1 | SMLS7-2 | SMLS7-2 | SMLS7-2 | SMLS7-3 | SMLS7-3 | SMLS7-3 | SMLS7-4 | SMLS7-4 |
|-----------------------------|--------------|--------------|--------------|--------------|--------------|--------------|---------------|---------------|----------------|----------------|---------------|----------|----------------|----------------|----------|---------------|--------------|
| Sampling Date | 3/24/2015 | 3/24/2015 | 3/24/2015 | 3/24/2015 | 3/24/2015 | 3/24/2015 | 3/17/2015 | 12/8/2015 | 8/3/2016 | 3/23/2015 | 12/8/2015 | 8/3/2016 | 3/17/2015 | 12/8/2015 | 8/3/2016 | 3/23/2015 | 12/8/2015 |
| VOCs (GC/MS) | µg/L | µg/L | µg/L | µg/L | µg/L | µg/L | µg/L | µg/L | µg/L | µg/L | µg/L | µg/L | µg/L | µg/L | µg/L | µg/L | µg/L |
| dichlorodifluoromethane | 5.0 U | 5.0 U | 5.0 U | 5.0 U | 5.0 U | 5.0 U | 21.0 U | 5.0 U | 42.0 U | 21.0 U | 5.0 U | -- | 21.0 U | 42.0 U | -- | 21.0 U | 5.0 U |
| chloromethane | 5.0 U | 5.0 U | 5.0 U | 5.0 U | 5.0 U | 5.0 U | 21.0 U | 14.8 | 42.0 U | 21.0 U | 27.4 | -- | 21.0 U | 155 D | -- | 21.0 U | 5.0 U |
| vinyl chloride | 5.0 U | 5.0 U | 5.0 U | 5.0 U | 5.0 U | 5.0 U | 270 D | 1010 D | 3420 D | 2340 D | 2230 D | -- | 9390 D | 9300 D | -- | 777 D | 845 D |
| bromomethane | 5.0 U | 5.0 U | 5.0 U | 5.0 U | 5.0 U | 5.0 U | 21.0 U | 5.0 U | 42.0 U | 21.0 U | 5.0 U | -- | 21.0 U | 42.0 U | -- | 21.0 U | 5.0 U |
| chloroethane | 5.0 U | 5.0 U | 5.0 U | 5.0 U | 5.0 U | 5.0 U | 21.0 U | 5.0 U | 42.0 U | 21.0 U | 5.0 U | -- | 21.0 U | 42.0 U | -- | 21.0 U | 5.0 U |
| trichlorofluoromethane | 5.0 U | 5.0 U | 5.0 U | 5.0 U | 5.0 U | 5.0 U | 21.0 U | 5.0 U | 42.0 U | 21.0 U | 5.0 U | -- | 21.0 U | 42.0 U | -- | 21.0 U | 5.0 U |
| 1,1-dichloroethylene | 5.0 U | 5.0 U | 5.0 U | 5.0 U | 5.0 U | 5.0 U | 21.0 U | 5.0 U | 42.0 U | 2.1 JD | 5.0 U | -- | 6.8 JD | 42.0 U | -- | 21.0 U | 5.0 U |
| methylene chloride | 5.0 U | 5.0 U | 5.0 U | 5.0 U | 5.0 U | 5.0 U | 21.0 U | 5.0 U | 42.0 U | 21.0 U | 5.0 U | -- | 21.0 U | 42.0 U | -- | 21.0 U | 5.0 U |
| trans-1,2-dichloroethylene | 5.0 U | 5.0 U | 5.0 U | 5.0 U | 5.0 U | 5.0 U | 6.6 JD | 16.5 | 10.2 JD | 22.9 D | 10.6 | -- | 43.1 D | 17.9 JD | -- | 39.6 D | 27.1 |
| 1,1-dichloroethane | 5.0 U | 5.0 U | 5.0 U | 0.5 J | 5.0 U | 5.0 U | 21.0 U | 5.0 U | 42.0 U | 21.0 U | 5.0 U | -- | 21.0 U | 42.0 U | -- | 21.0 U | 5.0 U |
| 2,2-dichloropropane | 5.0 U | 5.0 U | 5.0 U | 5.0 U | 5.0 U | 5.0 U | 21.0 U | 5.0 U | 42.0 U | 21.0 U | 5.0 U | -- | 21.0 U | 42.0 U | -- | 21.0 U | 5.0 U |
| cis 1,2- dichloroethylene | 5.0 U | 5.0 U | 5.0 U | 5.0 U | 5.0 U | 5.0 U | 257 D | 608 D | 2090 D | 1780 D | 820 D | -- | 7050 D | 3340 D | -- | 1800 D | 723 D |
| bromochloromethane | 5.0 U | 5.0 U | 5.0 U | 5.0 U | 5.0 U | 5.0 U | 21.0 U | 5.0 U | 42.0 U | 21.0 U | 5.0 U | -- | 21.0 U | 42.0 U | -- | 21.0 U | 5.0 U |
| chloroform | 5.0 U | 5.0 U | 5.0 U | 5.0 U | 5.0 U | 5.0 U | 21.0 U | 5.0 U | 42.0 U | 21.0 U | 5.0 U | -- | 21.0 U | 42.0 U | -- | 21.0 U | 5.0 U |
| 1,1,1-trichloroethane | 5.0 U | 5.0 U | 5.0 U | 5.0 U | 5.0 U | 5.0 U | 21.0 U | 5.0 U | 42.0 U | 21.0 U | 5.0 U | -- | 21.0 U | 42.0 U | -- | 21.0 U | 5.0 U |
| carbon tetrachloride | 5.0 U | 5.0 U | 5.0 U | 5.0 U | 5.0 U | 5.0 U | 21.0 U | 5.0 U | 42.0 U | 21.0 U | 5.0 U | -- | 21.0 U | 42.0 U | -- | 21.0 U | 5.0 U |
| 1,1-dichloropropene | 5.0 U | 5.0 U | 5.0 U | 5.0 U | 5.0 U | 5.0 U | 21.0 U | 5.0 U | 42.0 U | 21.0 U | 5.0 U | -- | 21.0 U | 42.0 U | -- | 21.0 U | 5.0 U |
| benzene | 5.0 U | 5.0 U | 5.0 U | 5.0 U | 5.0 U | 5.0 U | 21.0 U | 5.0 U | 42.0 U | 21.0 U | 0.9 J | -- | 21.0 U | 42.0 U | -- | 21.0 U | 5.0 U |
| 1,2-dichloroethane | 5.0 U | 5.0 U | 5.0 U | 5.0 U | 5.0 U | 5.0 U | 21.0 U | 5.0 U | 42.0 U | 21.0 U | 5.0 U | -- | 21.0 U | 42.0 U | -- | 21.0 U | 5.0 U |
| trichloroethylene | 5.0 U | 5.0 U | 5.0 U | 5.0 U | 5.0 U | 5.0 U | 21.0 U | 5.0 U | 42.0 U | 11.5 JD | 2.2 J | -- | 15.9 JD | 20.6 JD | -- | 21.0 U | 5.0 U |
| 1,2-dichloropropane | 5.0 U | 5.0 U | 5.0 U | 5.0 U | 5.0 U | 5.0 U | 21.0 U | 5.0 U | 42.0 U | 21.0 U | 5.0 U | -- | 21.0 U | 42.0 U | -- | 21.0 U | 5.0 U |
| dibromomethane | 5.0 U | 5.0 U | 5.0 U | 5.0 U | 5.0 U | 5.0 U | 21.0 U | 5.0 U | 42.0 U | 21.0 U | 5.0 U | -- | 21.0 U | 42.0 U | -- | 21.0 U | 5.0 U |
| bromodichloromethane | 5.0 U | 5.0 U | 5.0 U | 5.0 U | 5.0 U | 5.0 U | 21.0 U | 5.0 U | 42.0 U | 21.0 U | 5.0 U | -- | 21.0 U | 42.0 U | -- | 21.0 U | 5.0 U |
| cis-1,3-dichloropropene | 5.0 U | 5.0 U | 5.0 U | 5.0 U | 5.0 U | 5.0 U | 21.0 U | 5.0 U | 42.0 U | 21.0 U | 5.0 U | -- | 21.0 U | 42.0 U | -- | 21.0 U | 5.0 U |
| toluene | 5.0 U | 5.0 U | 5.0 U | 5.0 U | 5.0 U | 5.0 U | 2.9 JD | 2.2 J | 42.0 U | 5.9 JD | 3.8 J | -- | 5.6 JD | 42.0 U | -- | 3.3 JD | 2.5 J |
| trans-1,3-dichloropropene | 5.0 U | 5.0 U | 5.0 U | 5.0 U | 5.0 U | 5.0 U | 21.0 U | 5.0 U | 42.0 U | 21.0 U | 5.0 U | -- | 21.0 U | 42.0 U | -- | 21.0 U | 5.0 U |
| 1,1,2-trichloroethane | 5.0 U | 5.0 U | 5.0 U | 5.0 U | 5.0 U | 5.0 U | 21.0 U | 5.0 U | 42.0 U | 21.0 U | 5.0 U | -- | 21.0 U | 42.0 U | -- | 21.0 U | 5.0 U |
| tetrachloroethylene | 5.0 U | 5.0 U | 5.0 U | 5.0 U | 5.0 U | 5.0 U | 21.0 U | 5.0 U | 42.0 U | 21.0 U | 5.0 U | -- | 21.0 U | 42.0 U | -- | 21.0 U | 5.0 U |
| 1,3-dichloropropane | 5.0 U | 5.0 U | 5.0 U | 5.0 U | 5.0 U | 5.0 U | 21.0 U | 5.0 U | 42.0 U | 21.0 U | 5.0 U | -- | 21.0 U | 42.0 U | -- | 21.0 U | 5.0 U |
| dibromochloromethane | 5.0 U | 5.0 U | 5.0 U | 5.0 U | 5.0 U | 5.0 U | 21.0 U | 5.0 U | 42.0 U | 21.0 U | 5.0 U | -- | 21.0 U | 42.0 U | -- | 21.0 U | 5.0 U |
| 1,2-dibromoethane | 5.0 U | 5.0 U | 5.0 U | 5.0 U | 5.0 U | 5.0 U | 21.0 U | 5.0 U | 42.0 U | 21.0 U | 5.0 U | -- | 21.0 U | 42.0 U | -- | 21.0 U | 5.0 U |
| chlorobenzene | 61.6 | 1.6 J | 58.0 | 37.7 | 45.2 | 63.9 | 689 D | 424 D | 293 D | 1160 D | 729 D | -- | 318 D | 303 D | -- | 17.7 D | 265 D |
| 1,1,1,2-tetrachloroethane | 5.0 U | 5.0 U | 5.0 U | 5.0 U | 5.0 U | 5.0 U | 21.0 U | 5.0 U | 42.0 U | 21.0 U | 5.0 U | -- | 21.0 U | 42.0 U | -- | 21.0 U | 5.0 U |
| ethylbenzene | 5.0 U | 5.0 U | 5.0 U | 5.0 U | 5.0 U | 5.0 U | 21.0 U | 0.9 J | 42.0 U | 2.4 JD | 1.3 J | -- | 21.0 U | 42.0 U | -- | 21.0 U | 0.9 J |
| xylene (m/p) | 10.0 U | 10.0 U | 10.0 U | 10.0 U | 10.0 U | 10.0 U | 2.4 JD | 1.2 J | 42.0 U | 6.4 JD | 3.1 J | -- | 4.3 JD | 84.0 U | -- | 2.8 JD | 1.3 J |
| o-xylene | 5.0 U | 5.0 U | 5.0 U | 5.0 U | 5.0 U | 5.0 U | 21.0 U | 1.5 J | 42.0 U | 7.0 JD | 3.4 J | -- | 5.0 JD | 42.0 U | -- | 3.2 JD | 2.2 J |
| styrene | 5.0 U | 5.0 U | 5.0 U | 5.0 U | 5.0 U | 5.0 U | 21.0 U | 5.0 U | 42.0 U | 21.0 U | 5.0 U | -- | 21.0 U | 42.0 U | -- | 21.0 U | 5.0 U |
| bromoform | 5.0 U | 5.0 U | 5.0 U | 5.0 U | 5.0 U | 5.0 U | 21.0 U | 5.0 U | 42.0 U | 21.0 U | 5.0 U | -- | 21.0 U | 42.0 U | -- | 21.0 U | 5.0 U |
| isopropyl benzene (cumene) | 5.0 U | 5.0 U | 5.0 U | 5.0 U | 5.0 U | 5.0 U | 21.0 U | 1.4 J | 42.0 U | 2.6 JD | 2.2 J | -- | 2.7 JD | 42.0 U | -- | 21.0 U | 1.0 J |
| bromobenzene | 5.0 U | 5.0 U | 5.0 U | 5.0 U | 5.0 U | 5.0 U | 21.0 U | 5.0 U | 42.0 U | 21.0 U | 5.0 U | -- | 21.0 U | 42.0 U | -- | 21.0 U | 5.0 U |
| 1,1,2,2-tetrachloroethane | 5.0 U | 5.0 U | 5.0 U | 5.0 U | 5.0 U | 5.0 U | 21.0 U | 5.0 U | 42.0 U | 21.0 U | 5.0 U | -- | 21.0 U | 42.0 U | -- | 21.0 U | 5.0 U |
| 1,2,3-trichloropropane | 5.0 U | 5.0 U | 5.0 U | 5.0 U | 5.0 U | 5.0 U | 21.0 U | 5.0 U | 42.0 U | 5.4 JD | 5.0 U | -- | 21.0 U | 42.0 U | -- | 21.0 U | 5.0 U |
| n-propyl benzene | 5.0 U | 5.0 U | 5.0 U | 5.0 U | 5.0 U | 5.0 U | 21.0 U | 0.8 J | 42.0 U | 21.0 U | 1.2 J | -- | 21.0 U | 42.0 U | -- | 21.0 U | 0.6 J |
| 2-chlorotoluene | 5.0 U | 5.0 U | 5.0 U | 5.0 U | 5.0 U | 5.0 U | 21.0 U | 5.0 U | 42.0 U | 21.0 U | 5.0 U | -- | 21.0 U | 42.0 U | -- | 21.0 U | 5.0 U |
| 4-chlorotoluene | 5.0 U | 5.0 U | 5.0 U | 5.0 U | 5.0 U | 5.0 U | 21.0 U | 5.0 U | 42.0 U | 21.0 U | 5.0 U | -- | 21.0 U | 42.0 U | -- | 21.0 U | 5.0 U |
| 1,3,5-trimethylbenzene | 5.0 U | 5.0 U | 5.0 U | 5.0 U | 5.0 U | 5.0 U | 21.0 U | 0.8 J | 42.0 U | 3.8 JD | 1.3 J | -- | 2.4 JD | 42.0 U | -- | 21.0 U | 0.5 J |
| tert-butylbenzene | 5.0 U | 5.0 U | 5.0 U | 5.0 U | 5.0 U | 5.0 U | 21.0 U | 5.0 U | 42.0 U | 21.0 U | 5.0 U | -- | 21.0 U | 42.0 U | -- | 21.0 U | 5.0 U |
| 1,2,4-trimethylbenzene | 5.0 U | 5.0 U | 5.0 U | 5.0 U | 5.0 U | 5.0 U | 2.8 JD | 5.0 U | 42.0 U | 8.1 JD | 3.4 J | -- | 8.1 JD | 42.0 U | -- | 2.3 JD | 5.0 U |
| sec-butylbenzene | 5.0 U | 5.0 U | 5.0 U | 5.0 U | 5.0 U | 5.0 U | 21.0 U | 0.8 J | 42.0 U | 21.0 U | 0.8 J | -- | 21.0 U | 42.0 U | -- | 21.0 U | 5.0 U |
| 1,3-dichlorobenzene | 5.0 U | 5.0 U | 0.7 J | 0.6 J | 0.7 J | 0.6 J | 6.9 JD | 5.1 | 42.0 U | 11.6 JD | 5.4 | -- | 8.4 JD | 4.7 JD | -- | 5.1 JD | 3.4 J |
| 4-isopropyltoluene | 5.0 U | 5.0 U | 5.0 U | 5.0 U | 5.0 U | 5.0 U | 21.0 U | 5.0 U | 42.0 U | 21.0 U | 5.0 U | -- | 21.0 U | 42.0 U | -- | 21.0 U | 5.0 U |
| 1,4-dichlorobenzene | 2.8 J | 5.0 U | 4.2 J | 4.5 J | 4.8 J | 4.0 J | 58.5 D | 42.0 | 42.2 D | 76.9 D | 61.7 | -- | 77.7 D | 47.0 D | -- | 30.4 D | 31.8 |
| 1,2-dichlorobenzene | 3.8 J | 5.0 U | 3.2 J | 3.8 J | 3.9 J | 2.5 J | 38.9 D | 61.7 | 134 D | 152 D | 83.4 | -- | 666 D | 358 D | -- | 101 D | 126 |
| n-butylbenzene | 5.0 U | 5.0 U | 5.0 U | 5.0 U | 5.0 U | 5.0 U | 21.0 U | 5.0 U | 42.0 U | 21.0 U | 5.0 U | -- | 21.0 U | 42.0 U | -- | 21.0 U | 5.0 U |
| 1,2-dibromo-3-chloropropane | 5.0 U | 5.0 U | 5.0 U | 5.0 U | 5.0 U | 5.0 U | 21.0 U | 5.0 U | 42.0 U | 21.0 U | 5.0 U | -- | 21.0 U | 42.0 U | -- | 21.0 U | 5.0 U |
| 1,2,4-trichlorobenzene | 5.0 U | 5.0 U | 5.0 U | 5.0 U | 5.0 U | 5.0 U | 21.0 U | 5.0 U | 42.0 U | 21.0 U | 5.0 U | -- | 21.0 U | 42.0 U | -- | 21.0 U | 5.0 U |
| hexachlorobutadiene | 5.0 U | 5.0 U | 5.0 U | 5.0 U | 5.0 U | 5.0 U | 21.0 U | 5.0 U | 42.0 U | 21.0 U | 5.0 U | -- | 21.0 U | 42.0 U | -- | 21.0 U | 5.0 U |
| naphthalene | 5.0 U | 5.0 U | 5.0 U | 5.0 U | 5.0 U | 5.0 U | 21.0 U | 1.0 J | 42.0 U | 21.0 U | 1.2 J | -- | 21.0 U | 8.2 JD | -- | 21.0 U | 5.0 U |
| 1,2,3-trichlorobenzene | 5.0 U | 5.0 U | 5.0 U | 5.0 U | 5.0 U | 5.0 U | 21.0 U | 0.6 J | 42.0 U | 21.0 U | 5.0 U | -- | 21.0 U | 5.7 JD | -- | 21.0 U | 5.0 U |
| Methyl tertiary butyl ether | 5.0 U | 5.0 U | 5.0 U | 5.0 U | 5.0 U | 5.0 U | 21.0 U | 5.0 U | 42.0 U | 21.0 U | 5.0 U | -- | 21.0 U | 42.0 U | -- | 21.0 U | 5.0 U |
| Acetone | 32.9 | 4.3 J | 10.0 U | 10.0 U | 10.0 U | 2.1 J | 42.0 U | 0.7 J | 84.0 U | 42.0 U | 10.0 U | -- | 42.0 U | 84.0 U | -- | 42.0 U | 10.0 U |
| carbon disulfide | 6.4 | 5.0 U | 1.7 J | 5.0 U | 0.5 J | 5.0 U | 21.0 U | 5.0 U | 42.0 U | 21.0 U | 5.0 U | -- | 21.0 U | 42.0 U | -- | 21.0 U | 9.5 |
| 2-butanone (MEK) | 7.8 | 10.0 U | 10.0 U | 10.0 U | 10.0 U | 10.0 U | 42.0 U | 10.0 U | 84.0 U | 42.0 U | 10.0 U | -- | 42.0 U | 84.0 U | -- | 42.0 U | 10.0 U |
| tetrahydrofuran (THF) | 7.7 | 10.0 U | 10.0 U | 10.0 U | 10.0 U | 10.0 U | 42.0 U | 10.0 U | 84.0 U | 25.0 JD | 13.8 | -- | 42.0 U | 84.0 U | -- | 42.0 U | 10.0 U |
| 4-methyl-2-pentanone (MIBK) | 10.0 U | 10.0 U | 10.0 U | 10.0 U | 10.0 U | 10.0 U | 42.0 U | 10.0 U | 84.0 U | 42.0 U | 10.0 U | -- | 42.0 U | 84.0 U | -- | 42.0 U | 10.0 U |

APPENDIX D.1: GROUNDWATER ANALYTICAL DATA SUMMARY (VOCs)

| Sample ID | SPW3-2 | PEW01 | PEW01 | PEW01 | PEW02 | PEW02 | PEW02 | PEW03 | PEW03 | PEW03 | PEW04 | PEW04 | PEW04 | PMLS1-1 | PMLS1-1 | PMLS1-2 | PMLS1-2 | |
|-----------------------------|-----------|-----------|-----------|----------|-----------|-----------|-----------|-----------|-----------|-----------|-----------|-----------|-----------|----------|-----------|----------|-----------|-------|
| Sampling Date | 8/11/2016 | 3/16/2015 | 12/9/2015 | 8/2/2016 | 3/16/2015 | 12/9/2015 | 8/11/2016 | 3/16/2015 | 12/9/2015 | 8/11/2016 | 3/16/2015 | 12/9/2015 | 8/11/2016 | 3/9/2015 | 12/1/2015 | 3/9/2015 | 12/1/2015 | |
| VOCs (GC/MS) | µg/L | µg/L | µg/L | µg/L | µg/L | µg/L | µg/L | µg/L | µg/L | µg/L | µg/L | µg/L | µg/L | µg/L | µg/L | µg/L | µg/L | |
| dichlorodifluoromethane | 42.0 U | 5.0 U | 5.0 U | 42.0 U | 21.0 U | 5.0 U | 5.0 U | 5.0 U | 5.0 U | 5.0 U | 5.0 U | 5.0 U | 5.0 U | 5.0 U | 21.0 U | 5.0 U | 21.0 U | 5.0 U |
| chloromethane | 42.0 U | 5.0 U | 5.0 U | 42.0 U | 21.0 U | 5.0 U | 5.0 U | 5.0 U | 5.0 U | 5.0 U | 5.0 U | 5.0 U | 5.0 U | 5.0 U | 21.0 U | 5.0 U | 6.6 JD | 5.0 U |
| vinyl chloride | 3950 D | 123 | 289 D | 4050 D | 2620 D | 1270 D | 1520 D | 1.5 J | 213 D | 7.05 | 6.2 | 442 D | 369 D | 778 D | 2040 D | 1490 D | 29.3 | |
| bromomethane | 42.0 U | 5.0 U | 5.0 U | 42.0 U | 21.0 U | 5.0 U | 5.0 U | 5.0 U | 5.0 U | 5.0 U | 5.0 U | 5.0 U | 5.0 U | 5.0 U | 21.0 U | 5.0 U | 21.0 U | 5.0 U |
| chloroethane | 42.0 U | 5.0 U | 5.0 U | 42.0 U | 21.0 U | 5.0 U | 5.0 U | 0.6 J | 5.0 U | 5.0 U | 5.0 U | 5.0 U | 5.0 U | 5.0 U | 21.0 U | 5.0 U | 21.0 U | 5.0 U |
| trichlorofluoromethane | 42.0 U | 5.0 U | 5.0 U | 42.0 U | 21.0 U | 5.0 U | 5.0 U | 5.0 U | 5.0 U | 5.0 U | 5.0 U | 5.0 U | 5.0 U | 5.0 U | 21.0 U | 5.0 U | 21.0 U | 5.0 U |
| 1,1-dichloroethylene | 42.0 U | 5.0 U | 5.0 U | 42.0 U | 2.6 JD | 2.3 J | 4.46 J | 5.0 U | 5.0 U | 5.0 U | 5.0 U | 5.0 U | 27.6 | 36.2 | 12.2 JD | 12.1 | 21.0 U | 5.0 U |
| methylene chloride | 42.0 U | 5.0 U | 5.0 U | 42.0 U | 21.0 U | 5.0 U | 5.0 U | 5.0 U | 5.0 U | 5.0 U | 5.0 U | 5.0 U | 5.0 U | 5.0 U | 21.0 U | 5.0 U | 21.0 U | 5.0 U |
| trans-1,2-dichloroethylene | 34.4 JD | 5.0 U | 5.0 U | 42.0 U | 4.2 JD | 2.7 J | 5.86 | 5.0 U | 5.0 U | 5.0 U | 5.0 U | 5.0 U | 4.9 J | 2.70 J | 538 D | 560 D | 12.8 JD | 2.7 J |
| 1,1-dichloroethane | 42.0 U | 5.0 U | 5.0 U | 42.0 U | 21.0 U | 5.0 U | 1.50 J | 0.6 J | 5.0 U | 1.13 J | 1.5 J | 3.0 J | 2.56 J | 21.0 U | 5.0 U | 21.0 U | 5.0 U | |
| 2,2-dichloropropane | 42.0 U | 5.0 U | 5.0 U | 42.0 U | 21.0 U | 5.0 U | 5.0 U | 5.0 U | 5.0 U | 5.0 U | 5.0 U | 5.0 U | 5.0 U | 5.0 U | 21.0 U | 5.0 U | 21.0 U | 5.0 U |
| cis 1,2-dichloroethylene | 12100 D | 32.4 | 20.3 | 1370 D | 1030 D | 700 D | 1540 D | 2.5 J | 22.8 | 1.28 J | 4.0 J | 989 D | 672 D | 3760 D | 2340 D | 65.4 D | 8.2 | |
| bromochloromethane | 42.0 U | 5.0 U | 5.0 U | 42.0 U | 21.0 U | 5.0 U | 5.0 U | 5.0 U | 5.0 U | 5.0 U | 5.0 U | 5.0 U | 5.0 U | 5.0 U | 21.0 U | 5.0 U | 21.0 U | 5.0 U |
| chloroform | 42.0 U | 5.0 U | 5.0 U | 42.0 U | 21.0 U | 5.0 U | 5.0 U | 5.0 U | 5.0 U | 5.0 U | 5.0 U | 5.0 U | 5.0 U | 5.0 U | 21.0 U | 5.0 U | 21.0 U | 5.0 U |
| 1,1,1-trichloroethane | 42.0 U | 5.0 U | 5.0 U | 42.0 U | 21.0 U | 5.0 U | 5.0 U | 5.0 U | 5.0 U | 5.0 U | 5.0 U | 5.0 U | 5.0 U | 5.0 U | 21.0 U | 5.0 U | 21.0 U | 5.0 U |
| carbon tetrachloride | 42.0 U | 5.0 U | 5.0 U | 42.0 U | 21.0 U | 5.0 U | 5.0 U | 5.0 U | 5.0 U | 5.0 U | 5.0 U | 5.0 U | 5.0 U | 5.0 U | 21.0 U | 5.0 U | 21.0 U | 5.0 U |
| 1,1-dichloropropene | 42.0 U | 5.0 U | 5.0 U | 42.0 U | 21.0 U | 5.0 U | 5.0 U | 5.0 U | 5.0 U | 5.0 U | 5.0 U | 5.0 U | 5.0 U | 5.0 U | 21.0 U | 5.0 U | 21.0 U | 5.0 U |
| benzene | 42.0 U | 5.0 U | 5.0 U | 42.0 U | 21.0 U | 5.0 U | 5.0 U | 5.0 U | 5.0 U | 5.0 U | 5.0 U | 5.0 U | 5.0 U | 5.0 U | 21.0 U | 5.0 U | 21.0 U | 5.0 U |
| 1,2-dichloroethane | 42.0 U | 5.0 U | 5.0 U | 42.0 U | 21.0 U | 5.0 U | 5.0 U | 5.0 U | 5.0 U | 5.0 U | 5.0 U | 5.0 U | 5.0 U | 5.0 U | 3.1 JD | 1.7 J | 21.0 U | 5.0 U |
| trichloroethylene | 33.9 JD | 5.0 U | 0.8 J | 42.0 U | 21.0 U | 5.0 U | 1.84 J | 5.0 U | 5.0 U | 5.0 U | 1.0 J | 8.7 | 23.0 | 954 D | 861 D | 4.6 JD | 3.7 J | |
| 1,2-dichloropropane | 42.0 U | 5.0 U | 5.0 U | 42.0 U | 21.0 U | 5.0 U | 5.0 U | 5.0 U | 5.0 U | 5.0 U | 5.0 U | 5.0 U | 5.0 U | 5.0 U | 21.0 U | 5.0 U | 21.0 U | 5.0 U |
| dibromomethane | 42.0 U | 5.0 U | 5.0 U | 42.0 U | 21.0 U | 5.0 U | 5.0 U | 5.0 U | 5.0 U | 5.0 U | 5.0 U | 5.0 U | 5.0 U | 5.0 U | 21.0 U | 5.0 U | 21.0 U | 5.0 U |
| bromodichloromethane | 42.0 U | 5.0 U | 5.0 U | 42.0 U | 21.0 U | 5.0 U | 5.0 U | 5.0 U | 5.0 U | 5.0 U | 5.0 U | 5.0 U | 5.0 U | 5.0 U | 21.0 U | 5.0 U | 21.0 U | 5.0 U |
| cis-1,3-dichloropropene | 42.0 U | 5.0 U | 5.0 U | 42.0 U | 21.0 U | 5.0 U | 5.0 U | 5.0 U | 5.0 U | 5.0 U | 5.0 U | 5.0 U | 5.0 U | 5.0 U | 21.0 U | 5.0 U | 21.0 U | 5.0 U |
| toluene | 42.0 U | 0.9 J | 1.3 J | 42.0 U | 21.0 U | 5.0 U | 5.0 U | 5.0 U | 5.0 U | 5.0 U | 5.0 U | 5.0 U | 5.0 U | 5.0 U | 21.0 U | 0.6 J | 21.0 U | 5.0 U |
| trans-1,3-dichloropropene | 42.0 U | 5.0 U | 5.0 U | 42.0 U | 21.0 U | 5.0 U | 5.0 U | 5.0 U | 5.0 U | 5.0 U | 5.0 U | 5.0 U | 5.0 U | 5.0 U | 21.0 U | 5.0 U | 21.0 U | 5.0 U |
| 1,1,2-trichloroethane | 42.0 U | 5.0 U | 5.0 U | 42.0 U | 21.0 U | 5.0 U | 5.0 U | 5.0 U | 5.0 U | 5.0 U | 5.0 U | 5.0 U | 5.0 U | 5.0 U | 21.0 U | 5.0 U | 21.0 U | 5.0 U |
| tetrachloroethylene | 42.0 U | 5.0 U | 5.0 U | 42.0 U | 21.0 U | 5.0 U | 5.0 U | 5.0 U | 5.0 U | 5.0 U | 5.0 U | 5.0 U | 5.0 U | 5.0 U | 21.0 U | 5.0 U | 21.0 U | 5.0 U |
| 1,3-dichloropropane | 42.0 U | 5.0 U | 5.0 U | 42.0 U | 21.0 U | 5.0 U | 5.0 U | 5.0 U | 5.0 U | 5.0 U | 5.0 U | 5.0 U | 5.0 U | 5.0 U | 21.0 U | 5.0 U | 21.0 U | 5.0 U |
| dibromochloromethane | 42.0 U | 5.0 U | 5.0 U | 42.0 U | 21.0 U | 5.0 U | 5.0 U | 5.0 U | 5.0 U | 5.0 U | 5.0 U | 5.0 U | 5.0 U | 5.0 U | 21.0 U | 5.0 U | 21.0 U | 5.0 U |
| 1,2-dibromoethane | 42.0 U | 5.0 U | 5.0 U | 42.0 U | 21.0 U | 5.0 U | 5.0 U | 5.0 U | 5.0 U | 5.0 U | 5.0 U | 5.0 U | 5.0 U | 5.0 U | 21.0 U | 5.0 U | 21.0 U | 5.0 U |
| chlorobenzene | 247 D | 176 | 246 D | 228 D | 102 D | 28.4 | 35.6 | 34.0 | 21.8 | 14.9 | 12.4 | 5.2 | 5.89 | 16.4 JD | 48.1 | 239 D | 30.2 | |
| 1,1,1,2-tetrachloroethane | 42.0 U | 5.0 U | 5.0 U | 42.0 U | 21.0 U | 5.0 U | 5.0 U | 5.0 U | 5.0 U | 5.0 U | 5.0 U | 5.0 U | 5.0 U | 5.0 U | 21.0 U | 5.0 U | 21.0 U | 5.0 U |
| ethylbenzene | 42.0 U | 5.0 U | 5.0 U | 42.0 U | 21.0 U | 5.0 U | 5.0 U | 5.0 U | 5.0 U | 5.0 U | 5.0 U | 5.0 U | 5.0 U | 5.0 U | 21.0 U | 5.0 U | 21.0 U | 5.0 U |
| xylenes (m/p) | 84.0 U | 0.8 J | 0.6 J | 42.0 U | 42.0 U | 10.0 U | 10.0 U | 10.0 U | 10.0 U | 5.0 U | 10.0 U | 10.0 U | 5.0 U | 42.0 U | 10.0 U | 42.0 U | 10.0 U | |
| o-xylene | 42.0 U | 5.0 U | 5.0 U | 42.0 U | 21.0 U | 5.0 U | 5.0 U | 5.0 U | 5.0 U | 5.0 U | 5.0 U | 5.0 U | 5.0 U | 5.0 U | 21.0 U | 5.0 U | 21.0 U | 5.0 U |
| styrene | 42.0 U | 5.0 U | 5.0 U | 42.0 U | 21.0 U | 5.0 U | 5.0 U | 5.0 U | 5.0 U | 5.0 U | 5.0 U | 5.0 U | 5.0 U | 5.0 U | 21.0 U | 5.0 U | 21.0 U | 5.0 U |
| bromoform | 42.0 U | 5.0 U | 5.0 U | 42.0 U | 21.0 U | 5.0 U | 5.0 U | 5.0 U | 5.0 U | 5.0 U | 5.0 U | 5.0 U | 5.0 U | 5.0 U | 21.0 U | 5.0 U | 21.0 U | 5.0 U |
| isopropyl benzene (cumene) | 42.0 U | 0.7 J | 1.0 J | 42.0 U | 21.0 U | 5.0 U | 5.0 U | 5.0 U | 5.0 U | 5.0 U | 5.0 U | 5.0 U | 5.0 U | 5.0 U | 21.0 U | 5.0 U | 21.0 U | 5.0 U |
| bromobenzene | 42.0 U | 5.0 U | 5.0 U | 42.0 U | 21.0 U | 5.0 U | 5.0 U | 5.0 U | 5.0 U | 5.0 U | 5.0 U | 5.0 U | 5.0 U | 5.0 U | 21.0 U | 5.0 U | 21.0 U | 5.0 U |
| 1,1,2,2-tetrachloroethane | 42.0 U | 5.0 U | 5.0 U | 42.0 U | 21.0 U | 5.0 U | 5.0 U | 5.0 U | 5.0 U | 5.0 U | 5.0 U | 5.0 U | 5.0 U | 5.0 U | 21.0 U | 5.0 U | 21.0 U | 5.0 U |
| 1,2,3-trichloropropane | 42.0 U | 5.0 U | 5.0 U | 42.0 U | 21.0 U | 5.0 U | 5.0 U | 5.0 U | 5.0 U | 5.0 U | 5.0 U | 5.0 U | 5.0 U | 5.0 U | 21.0 U | 5.0 U | 21.0 U | 5.0 U |
| n-propyl benzene | 42.0 U | 0.6 J | 0.8 J | 42.0 U | 21.0 U | 5.0 U | 5.0 U | 5.0 U | 5.0 U | 5.0 U | 5.0 U | 5.0 U | 5.0 U | 5.0 U | 21.0 U | 5.0 U | 21.0 U | 5.0 U |
| 2-chlorotoluene | 42.0 U | 5.0 U | 5.0 U | 42.0 U | 21.0 U | 5.0 U | 5.0 U | 5.0 U | 5.0 U | 5.0 U | 5.0 U | 5.0 U | 5.0 U | 5.0 U | 21.0 U | 5.0 U | 21.0 U | 5.0 U |
| 4-chlorotoluene | 42.0 U | 5.0 U | 5.0 U | 42.0 U | 21.0 U | 5.0 U | 5.0 U | 5.0 U | 5.0 U | 5.0 U | 5.0 U | 5.0 U | 5.0 U | 5.0 U | 21.0 U | 5.0 U | 21.0 U | 5.0 U |
| 1,3,5-trimethylbenzene | 42.0 U | 5.0 U | 0.8 J | 42.0 U | 21.0 U | 5.0 U | 5.0 U | 5.0 U | 5.0 U | 5.0 U | 5.0 U | 5.0 U | 5.0 U | 5.0 U | 21.0 U | 5.0 U | 21.0 U | 5.0 U |
| tert-butylbenzene | 42.0 U | 5.0 U | 5.0 U | 42.0 U | 21.0 U | 5.0 U | 5.0 U | 5.0 U | 5.0 U | 5.0 U | 5.0 U | 5.0 U | 5.0 U | 5.0 U | 21.0 U | 5.0 U | 21.0 U | 5.0 U |
| 1,2,4-trimethylbenzene | 42.0 U | 5.0 U | 0.9 J | 42.0 U | 21.0 U | 5.0 U | 5.0 U | 5.0 U | 5.0 U | 5.0 U | 5.0 U | 5.0 U | 5.0 U | 5.0 U | 21.0 U | 5.0 U | 21.0 U | 5.0 U |
| sec-butylbenzene | 42.0 U | 1.0 J | 5.0 U | 42.0 U | 21.0 U | 5.0 U | 5.0 U | 5.0 U | 5.0 U | 5.0 U | 5.0 U | 5.0 U | 5.0 U | 5.0 U | 21.0 U | 5.0 U | 21.0 U | 5.0 U |
| 1,3-dichlorobenzene | 42.0 U | 3.1 J | 3.2 J | 42.0 U | 2.6 JD | 0.7 J | 5.0 U | 0.6 J | 5.0 U | 5.0 U | 5.0 U | 5.0 U | 5.0 U | 5.0 U | 21.0 U | 0.7 J | 3.7 JD | 0.7 J |
| 4-isopropyltoluene | 42.0 U | 5.0 U | 5.0 U | 42.0 U | 21.0 U | 5.0 U | 5.0 U | 5.0 U | 5.0 U | 5.0 U | 5.0 U | 5.0 U | 5.0 U | 5.0 U | 21.0 U | 5.0 U | 21.0 U | 5.0 U |
| 1,4-dichlorobenzene | 33.6 JD | 18.6 | 26.6 | 32.7 JD | 15.0 JD | 5.8 | 7.22 | 2.5 J | 1.9 J | 1.64 J | 2.4 J | 2.7 J | 2.90 J | 6.6 JD | 7.4 | 24.7 D | 6.0 | |
| 1,2-dichlorobenzene | 60.0 D | 41.2 | 38.5 | 69.5 D | 36.0 D | 27.3 | 38.4 | 3.5 J | 3.2 J | 2.90 J | 6.2 | 16.0 | 23.8 | 60.8 D | 79.9 | 27.7 D | 9.6 | |
| n-butylbenzene | 42.0 U | 5.0 U | 5.0 U | 42.0 U | 21.0 U | 5.0 U | 5.0 U | 5.0 U | 5.0 U | 5.0 U | 5.0 U | 5.0 U | 5.0 U | 5.0 U | 21.0 U | 5.0 U | 21.0 U | 5.0 U |
| 1,2-dibromo-3-chloropropane | 42.0 U | 5.0 U | 5.0 U | 42.0 U | 21.0 U | 5.0 U | 5.0 U | 5.0 U | 5.0 U | 5.0 U | 5.0 U | 5.0 U | 5.0 U | 5.0 U | 21.0 U | 5.0 U | 21.0 U | 5.0 U |
| 1,2,4-trichlorobenzene | 42.0 U | 5.0 U | 5.0 U | 42.0 U | 21.0 U | 5.0 U | 5.0 U | 5.0 U | 5.0 U | 5.0 U | 5.0 U | 5.0 U | 5.0 U | 5.0 U | 21.0 U | 5.0 U | 21.0 U | 5.0 U |
| hexachlorobutadiene | 42.0 U | 5.0 U | 5.0 U | 42.0 U | 21.0 U | 5.0 U | 5.0 U | 5.0 U | 5.0 U | 5.0 U | 5.0 U | 5.0 U | 5.0 U | 5.0 U | 21.0 U | 5.0 U | 21.0 U | 5.0 U |
| naphthalene | 42.0 U | 5.0 U | 5.0 U | 42.0 U | 21.0 U | 5.0 U | 5.0 U | 5.0 U | 5.0 U | 5.0 U | 5.0 U | 5.0 U | 5.0 U | 5.0 U | 21.0 U | 5.0 U | 21.0 U | 5.0 U |
| 1,2,3-trichlorobenzene | 42.0 U | 5.0 U | 5.0 U | 42.0 U | 21.0 U | 5.0 U | 5.0 U | 5.0 U | 5.0 U | 5.0 U | 5.0 U | 5.0 U | 5.0 U | 5.0 U | 21.0 U | 5.0 U | 21.0 U | 5.0 U |
| Methyl tertiary butyl ether | 42.0 U | 5.0 U | 5.0 U | 42.0 U | 21.0 U | 5.0 U | 5.0 U | 5.0 U | 5.0 U | 5.0 U | 5.0 U | 5.0 U | 5.0 U | 5.0 U | 21.0 U | 5.0 U | 21.0 U | 5.0 U |
| Acetone | 84.0 U | 10.0 U | 10.0 U | 84.0 U | 42.0 U | 10.0 U | 10.0 U | 10.0 U | 10.0 U | 10.0 U | 10.0 U | 10.0 U | 10.0 U | 42.0 U | 10.0 U | 42.0 U | 10.0 U | |
| carbon disulfide | 42.0 U | 5.0 U | 5.0 U | 42.0 U | 21.0 U | 5.0 U | 5.0 U | 5.0 U | 5.0 U | 5.0 U | 5.0 U | 5.0 U | 5.0 U | 5.0 U | 21.0 U | 5.0 U | 21.0 U | 5.0 U |
| 2-butanone (MEK) | 84.0 U | 10.0 U | 10.0 U | 84.0 U | 42.0 U | 10.0 U | 10.0 U | 10.0 U | 10.0 U | 10.0 U | 10.0 U | 10.0 U | 10.0 U | 42.0 U | 10.0 U | 42.0 U | 10.0 U | |
| tetrahydrofuran (THF) | 84.0 U | 10.0 U | 10.0 U | 84.0 U | 42.0 U | 10.0 U | 10.0 U | 10.0 U | 10 | | | | | | | | | |

APPENDIX D.1: GROUNDWATER ANALYTICAL DATA SUMMARY (VOCs)

| Sample ID | PMLS2-6 | PMLS2-7 | PMLS3-1 | PMLS3-1 | PMLS3-1 | PMLS3-2 | PMLS3-2 | PMLS3-2 | PMLS3-3 | PMLS3-3 | PMLS3-3 | PMLS3-4 | PMLS3-4 | PMLS3-5 | PMLS3-5 | PMLS3-6 | PMLS3-7 | PMLS4-1 | PMLS4-1 | | |
|----------------------------|----------------|----------------|----------------|----------------|----------------|---------------|--------------|---------------|--------------|--------------|---------------|--------------|--------------|--------------|--------------|---------------|----------------|----------------|----------------|---------------|----------------|
| Sampling Date | 3/10/2015 | 3/10/2015 | 3/10/2015 | 12/2/2015 | 8/1/2016 | 3/10/2015 | 12/2/2015 | 8/1/2016 | 3/10/2015 | 12/2/2015 | 8/1/2016 | 3/10/2015 | 12/2/2015 | 3/10/2015 | 12/2/2015 | 3/10/2015 | 3/10/2015 | 3/11/2015 | 12/2/2015 | | |
| VOCs (GC/MS) | µg/L | µg/L | µg/L | µg/L | µg/L | µg/L | µg/L | µg/L | µg/L | µg/L | µg/L | µg/L | µg/L | µg/L | µg/L | µg/L | µg/L | µg/L | µg/L | | |
| dichlorodifluoromethane | 21.0 U | 21.0 U | 21.0 U | 42.0 U | 42.0 U | 21.0 U | 5.0 U | 5.0 U | 5.0 U | 5.0 U | 5.0 U | 5.0 U | 5.0 U | 5.0 U | 5.0 U | 5.0 U | 21.0 U | 21.0 U | 21.0 U | 42.0 U | |
| chloromethane | 21.0 U | 21.0 U | 21.0 U | 42.0 U | 42.0 U | 21.0 U | 5.0 U | 5.0 U | 5.0 U | 5.0 U | 5.0 U | 5.0 U | 5.0 U | 5.0 U | 5.0 U | 5.0 U | 21.0 U | 21.0 U | 21.0 U | 42.0 U | |
| vinyl chloride | 190 D | 500 D | 2590 D | 3040 D | 2430 D | 643 D | 986 D | 555 D | 4.4 J | 358 D | 112 | 14.7 | 2.9 J | 91.8 | 167 | 130 D | 627 D | 3840 D | 4750 D | | |
| bromomethane | 21.0 U | 21.0 U | 21.0 U | 42.0 U | 42.0 U | 21.0 U | 5.0 U | 5.0 U | 5.0 U | 5.0 U | 5.0 U | 5.0 U | 5.0 U | 5.0 U | 5.0 U | 5.0 U | 21.0 U | 21.0 U | 21.0 U | 42.0 U | |
| chloroethane | 5.7 JD | 21.0 U | 21.0 U | 42.0 U | 42.0 U | 21.0 U | 5.0 U | 5.0 U | 5.0 U | 5.0 U | 5.0 U | 5.0 U | 5.0 U | 5.0 U | 5.0 U | 5.0 U | 6.5 JD | 21.0 U | 21.0 U | 42.0 U | |
| trichlorofluoromethane | 21.0 U | 21.0 U | 21.0 U | 42.0 U | 42.0 U | 21.0 U | 5.0 U | 5.0 U | 5.0 U | 5.0 U | 5.0 U | 5.0 U | 5.0 U | 5.0 U | 5.0 U | 5.0 U | 21.0 U | 21.0 U | 21.0 U | 42.0 U | |
| 1,1-dichloroethylene | 4.3 JD | 5.6 JD | 60.6 D | 51.0 D | 40.4 JD | 3.9 JD | 17.1 | 6.60 | 5.0 U | 1.7 J | 5.0 U | 5.0 U | 5.0 U | 5.0 U | 5.0 U | 1.1 J | 0.9 J | 21.0 U | 5.9 JD | 47.4 D | 39.9 JD |
| methylene chloride | 21.0 U | 21.0 U | 21.0 U | 42.0 U | 42.0 U | 21.0 U | 5.0 U | 5.0 U | 5.0 U | 5.0 U | 5.0 U | 5.0 U | 5.0 U | 5.0 U | 5.0 U | 5.0 U | 21.0 U | 21.0 U | 21.0 U | 42.0 U | |
| trans-1,2-dichloroethylene | 2.9 JD | 117 D | 638 D | 440 D | 318 D | 108 D | 17.9 | 22.4 | 2.0 J | 0.7 J | 2.20 J | 3.6 J | 5.0 U | 5.6 | 10.2 | 7.9 JD | 166 D | 707 D | 820 D | | |
| 1,1-dichloroethane | 21.0 U | 21.0 U | 21.0 U | 42.0 U | 42.0 U | 21.0 U | 2.2 J | 2.00 J | 5.0 U | 5.0 U | 5.0 U | 5.0 U | 5.0 U | 5.0 U | 5.0 U | 5.0 U | 21.0 U | 21.0 U | 21.0 U | 42.0 U | |
| 2,2-dichloropropane | 21.0 U | 21.0 U | 21.0 U | 42.0 U | 42.0 U | 21.0 U | 5.0 U | 5.0 U | 5.0 U | 5.0 U | 5.0 U | 5.0 U | 5.0 U | 5.0 U | 5.0 U | 5.0 U | 21.0 U | 21.0 U | 21.0 U | 42.0 U | |
| cis 1,2-dichloroethylene | 291 D | 2090 D | 12400 D | 13300 D | 11000 D | 1350 D | 880 D | 472 D | 9.3 | 95.2 | 73.3 | 25 | 3.6 J | 179 | 301 D | 116 D | 2780 D | 12900 D | 12200 D | | |
| bromochloromethane | 21.0 U | 21.0 U | 21.0 U | 42.0 U | 42.0 U | 21.0 U | 5.0 U | 5.0 U | 5.0 U | 5.0 U | 5.0 U | 5.0 U | 5.0 U | 5.0 U | 5.0 U | 5.0 U | 21.0 U | 21.0 U | 21.0 U | 42.0 U | |
| chloroform | 21.0 U | 21.0 U | 21.0 U | 42.0 U | 42.0 U | 21.0 U | 5.0 U | 5.0 U | 5.0 U | 5.0 U | 5.0 U | 5.0 U | 5.0 U | 5.0 U | 5.0 U | 5.0 U | 21.0 U | 21.0 U | 21.0 U | 42.0 U | |
| 1,1,1-trichloroethane | 21.0 U | 21.0 U | 21.0 U | 42.0 U | 42.0 U | 21.0 U | 5.0 U | 5.0 U | 5.0 U | 5.0 U | 5.0 U | 5.0 U | 5.0 U | 5.0 U | 5.0 U | 5.0 U | 21.0 U | 21.0 U | 21.0 U | 42.0 U | |
| carbon tetrachloride | 21.0 U | 21.0 U | 21.0 U | 42.0 U | 42.0 U | 21.0 U | 5.0 U | 5.0 U | 5.0 U | 5.0 U | 5.0 U | 5.0 U | 5.0 U | 5.0 U | 5.0 U | 5.0 U | 21.0 U | 21.0 U | 21.0 U | 42.0 U | |
| 1,1-dichloropropene | 21.0 U | 21.0 U | 21.0 U | 42.0 U | 42.0 U | 21.0 U | 5.0 U | 5.0 U | 5.0 U | 5.0 U | 5.0 U | 5.0 U | 5.0 U | 5.0 U | 5.0 U | 5.0 U | 21.0 U | 21.0 U | 21.0 U | 42.0 U | |
| benzene | 21.0 U | 21.0 U | 21.0 U | 42.0 U | 42.0 U | 21.0 U | 5.0 U | 5.0 U | 5.0 U | 5.0 U | 5.0 U | 5.0 U | 5.0 U | 5.0 U | 5.0 U | 5.0 U | 21.0 U | 21.0 U | 21.0 U | 42.0 U | |
| 1,2-dichloroethane | 21.0 U | 21.0 U | 15.1 JD | 42.0 U | 42.0 U | 21.0 U | 5.0 U | 5.0 U | 5.0 U | 5.0 U | 5.0 U | 5.0 U | 5.0 U | 5.0 U | 5.0 U | 5.0 U | 21.0 U | 21.0 U | 21.3 D | 42.0 U | |
| trichloroethylene | 3210 D | 116 D | 20100 D | 7140 D | 4100 D | 41.2 D | 26.2 | 25.3 | 4.6 J | 2.9 J | 5.0 U | 6.7 | 0.8 J | 256 D | 133 | 1610 D | 261 D | 15900 D | 2940 D | | |
| 1,2-dichloropropane | 21.0 U | 21.0 U | 21.0 U | 42.0 U | 42.0 U | 21.0 U | 5.0 U | 5.0 U | 5.0 U | 5.0 U | 5.0 U | 5.0 U | 5.0 U | 5.0 U | 5.0 U | 5.0 U | 21.0 U | 21.0 U | 21.0 U | 42.0 U | |
| dibromomethane | 21.0 U | 21.0 U | 21.0 U | 42.0 U | 42.0 U | 21.0 U | 5.0 U | 5.0 U | 5.0 U | 5.0 U | 5.0 U | 5.0 U | 5.0 U | 5.0 U | 5.0 U | 5.0 U | 21.0 U | 21.0 U | 21.0 U | 42.0 U | |
| bromodichloromethane | 21.0 U | 21.0 U | 21.0 U | 42.0 U | 42.0 U | 21.0 U | 5.0 U | 5.0 U | 5.0 U | 5.0 U | 5.0 U | 5.0 U | 5.0 U | 5.0 U | 5.0 U | 5.0 U | 21.0 U | 21.0 U | 21.0 U | 42.0 U | |
| cis-1,3-dichloropropene | 21.0 U | 21.0 U | 21.0 U | 42.0 U | 42.0 U | 21.0 U | 5.0 U | 5.0 U | 5.0 U | 5.0 U | 5.0 U | 5.0 U | 5.0 U | 5.0 U | 5.0 U | 5.0 U | 21.0 U | 21.0 U | 21.0 U | 42.0 U | |
| toluene | 21.0 U | 21.0 U | 2.3 JD | 42.0 U | 42.0 U | 21.0 U | 5.0 U | 5.0 U | 5.0 U | 5.0 U | 5.0 U | 5.0 U | 5.0 U | 5.0 U | 5.0 U | 5.0 U | 21.0 U | 21.0 U | 21.0 U | 42.0 U | |
| trans-1,3-dichloropropene | 21.0 U | 21.0 U | 21.0 U | 42.0 U | 42.0 U | 21.0 U | 5.0 U | 5.0 U | 5.0 U | 5.0 U | 5.0 U | 5.0 U | 5.0 U | 5.0 U | 5.0 U | 5.0 U | 21.0 U | 21.0 U | 21.0 U | 42.0 U | |
| 1,1,2-trichloroethane | 21.0 U | 21.0 U | 21.0 U | 42.0 U | 42.0 U | 21.0 U | 5.0 U | 5.0 U | 5.0 U | 5.0 U | 5.0 U | 5.0 U | 5.0 U | 5.0 U | 5.0 U | 5.0 U | 21.0 U | 21.0 U | 21.0 U | 42.0 U | |
| tetrachloroethylene | 21.0 U | 21.0 U | 21.0 U | 42.0 U | 42.0 U | 21.0 U | 5.0 U | 5.0 U | 5.0 U | 5.0 U | 5.0 U | 5.0 U | 5.0 U | 5.0 U | 5.0 U | 5.0 U | 21.0 U | 21.0 U | 21.0 U | 42.0 U | |
| 1,3-dichloropropane | 21.0 U | 21.0 U | 21.0 U | 42.0 U | 42.0 U | 21.0 U | 5.0 U | 5.0 U | 5.0 U | 5.0 U | 5.0 U | 5.0 U | 5.0 U | 5.0 U | 5.0 U | 5.0 U | 21.0 U | 21.0 U | 21.0 U | 42.0 U | |
| dibromochloromethane | 21.0 U | 21.0 U | 21.0 U | 42.0 U | 42.0 U | 21.0 U | 5.0 U | 5.0 U | 5.0 U | 5.0 U | 5.0 U | 5.0 U | 5.0 U | 5.0 U | 5.0 U | 5.0 U | 21.0 U | 21.0 U | 21.0 U | 42.0 U | |
| 1,2-dibromoethane | 21.0 U | 21.0 U | 21.0 U | 42.0 U | 42.0 U | 21.0 U | 5.0 U | 5.0 U | 5.0 U | 5.0 U | 5.0 U | 5.0 U | 5.0 U | 5.0 U | 5.0 U | 5.0 U | 21.0 U | 21.0 U | 21.0 U | 42.0 U | |
| chlorobenzene | 3.2 JD | 12.5 JD | 8.3 JD | 7.6 JD | 10.5 JD | 22.9 D | 13.0 | 8.53 | 55.3 | 24.7 | 16.8 | 6.4 | 8.8 | 2.6 J | 3.0 J | 2.8 JD | 3.2 JD | 9.4 JD | 12.9 JD | | |
| 1,1,1,2-tetrachloroethane | 21.0 U | 21.0 U | 21.0 U | 42.0 U | 42.0 U | 21.0 U | 5.0 U | 5.0 U | 5.0 U | 5.0 U | 5.0 U | 5.0 U | 5.0 U | 5.0 U | 5.0 U | 5.0 U | 21.0 U | 21.0 U | 21.0 U | 42.0 U | |
| ethylbenzene | 21.0 U | 21.0 U | 21.0 U | 42.0 U | 42.0 U | 21.0 U | 5.0 U | 5.0 U | 5.0 U | 5.0 U | 5.0 U | 5.0 U | 5.0 U | 5.0 U | 5.0 U | 5.0 U | 21.0 U | 21.0 U | 21.0 U | 42.0 U | |
| xylenes (m/p) | 42.0 U | 42.0 U | 21.0 U | 84.0 U | 42.0 U | 21.0 U | 10.0 U | 5.0 U | 10.0 U | 10.0 U | 5.0 U | 5.0 U | 10.0 U | 5.0 U | 10.0 U | 21.0 U | 21.0 U | 42.0 U | 84.0 U | | |
| o-xylene | 21.0 U | 21.0 U | 21.0 U | 42.0 U | 42.0 U | 21.0 U | 5.0 U | 5.0 U | 5.0 U | 5.0 U | 5.0 U | 5.0 U | 5.0 U | 5.0 U | 5.0 U | 5.0 U | 21.0 U | 21.0 U | 21.0 U | 42.0 U | |
| styrene | 21.0 U | 21.0 U | 21.0 U | 42.0 U | 42.0 U | 21.0 U | 5.0 U | 5.0 U | 5.0 U | 5.0 U | 5.0 U | 5.0 U | 5.0 U | 5.0 U | 5.0 U | 5.0 U | 21.0 U | 21.0 U | 21.0 U | 42.0 U | |
| bromoform | 21.0 U | 21.0 U | 21.0 U | 42.0 U | 42.0 U | 21.0 U | 5.0 U | 5.0 U | 5.0 U | 5.0 U | 5.0 U | 5.0 U | 5.0 U | 5.0 U | 5.0 U | 5.0 U | 21.0 U | 21.0 U | 21.0 U | 42.0 U | |
| isopropyl benzene (cumene) | 21.0 U | 21.0 U | 21.0 U | 42.0 U | 42.0 U | 21.0 U | 5.0 U | 5.0 U | 5.0 U | 5.0 U | 5.0 U | 5.0 U | 5.0 U | 5.0 U | 5.0 U | 5.0 U | 21.0 U | 21.0 U | 21.0 U | 42.0 U | |
| bromobenzene | 21.0 U | 21.0 U | 21.0 U | 42.0 U | 42.0 U | 21.0 U | 5.0 U | 5.0 U | 5.0 U | 5.0 U | 5.0 U | 5.0 U | 5.0 U | 5.0 U | 5.0 U | 5.0 U | 21.0 U | 21.0 U | 21.0 U | 42.0 U | |
| 1,1,2,2-tetrachloroethane | 21.0 U | 21.0 U | 21.0 U | 42.0 U | 42.0 U | 21.0 U | 5.0 U | 5.0 U | 5.0 U | 5.0 U | 5.0 U | 5.0 U | 5.0 U | 5.0 U | 5.0 U | 5.0 U | 21.0 U | 21.0 U | 21.0 U | 42.0 U | |
| 1,2,3-trichloropropane | 21.0 U | 21.0 U | 21.0 U | 42.0 U | 42.0 U | 21.0 U | 5.0 U | 5.0 U | 5.0 U | 5.0 U | 5.0 U | 5.0 U | 5.0 U | 5.0 U | 5.0 U | 5.0 U | 21.0 U | 21.0 U | 21.0 U | 42.0 U | |
| n-propyl benzene | 21.0 U | 21.0 U | 21.0 U | 42.0 U | 42.0 U | 21.0 U | 5.0 U | 5.0 U | 5.0 U | 5.0 U | 5.0 U | 5.0 U | 5.0 U | 5.0 U | 5.0 U | 5.0 U | 21.0 U | 21.0 U | 21.0 U | 42.0 U | |
| 2-chlorotoluene | 21.0 U | 21.0 U | 21.0 U | 42.0 U | 42.0 U | 21.0 U | 5.0 U | 5.0 U | 5.0 U | 5.0 U | 5.0 U | 5.0 U | 5.0 U | 5.0 U | 5.0 U | 5.0 U | 21.0 U | 21.0 U | 21.0 U | 42.0 U | |
| 4-chlorotoluene | 21.0 U | 21.0 U | 21.0 U | 42.0 U | 42.0 U | 21.0 U | 5.0 U | 5.0 U | 5.0 U | 5.0 U | 5.0 U | 5.0 U | 5.0 U | 5.0 U | 5.0 U | 5.0 U | 21.0 U | 21.0 U | 21.0 U | 42.0 U | |
| 1,3,5-trimethylbenzene | 21.0 U | 21.0 U | 21.0 U | 42.0 U | 42.0 U | 21.0 U | 5.0 U | 5.0 U | 5.0 U | 5.0 U | 5.0 U | 5.0 U | 5.0 U | 5.0 U | 5.0 U | 5.0 U | 21.0 U | 21.0 U | 21.0 U | 42.0 U | |
| tert-butylbenzene | 21.0 U | 21.0 U | 21.0 U | 42.0 U | 42.0 U | 21.0 U | 5.0 U | 5.0 U | 5.0 U | 5.0 U | 5.0 U | 5.0 U | 5.0 U | 5.0 U | 5.0 U | 5.0 U | 21.0 U | 21.0 U | 21.0 U | 42.0 U | |
| 1,2,4-trimethylbenzene | 21.0 U | 21.0 U | 21.0 U | 42.0 U | 42.0 U | 21.0 U | 5.0 U | 5.0 U | 5.0 U | 5.0 U | 5.0 U | 5.0 U | 5.0 U | 5.0 U | 5.0 U | 5.0 U | 21.0 U | 21.0 U | 21.0 U | 42.0 U | |
| sec-butylbenzene | 21.0 U | 21.0 U | 21.0 U | 42.0 U | 42.0 U | 21.0 U | 5.0 U | 5.0 U | 5.0 U | 5.0 U | 5.0 U | 5.0 U | 5.0 U | 5.0 U | 5.0 U | 5.0 U | 21.0 U | 21.0 U | 21.0 U | 42.0 U | |
| 1,3-dichlorobenzene | 21.0 U | 21.0 U | 3.5 JD | 42.0 U | 42.0 U | 21.0 U | 5.0 U | 5.0 U | 1.0 J | 5.0 U | 5.0 U | 0.9 J | 0.7 J | 1.3 J | 1.0 J | 21.0 U | 21.0 U | 3.7 JD | 42.0 U | | |
| 4-isopropyltoluene | 21.0 U | 21.0 U | 21.0 U | 42.0 U | 42.0 U | 21.0 U | 5.0 U | 5.0 U | 5.0 U | 5.0 U | 5.0 U | 5.0 U | 5.0 U | 5.0 U | 5.0 U | 5.0 U | 21.0 U | 21.0 U | 21.0 U | 42.0 U | |
| 1,4-dichlorobenzene | 21.0 U | 21.0 U | 39.4 D | 27.2 JD | 27.9 JD | 6.2 JD | 5.5 | 4.65 J | 5.3 | 3.1 J | 2.84 J | 9.7 | 9.2 | 12.8 | 10.6 | 3.4 JD | 2.3 JD | 31.2 D | 27.6 JD | | |
| 1,2-dichlorobenzene | 17.0 JD | 13.7 JD | 337 D | 261.0 D | 251 D | 34.0 D | 30.4 | 30.2 | 13.7 | 6.8 | 8.77 | 73.9 | 60.1 | 93.4 | 69.4 | 39.6 D | 19.3 JD | 290 D | 239 D | | |

APPENDIX D.1: GROUNDWATER ANALYTICAL DATA SUMMARY (VOCs)

| Sample ID | PMLS4-1 | PMLS4-2 | PMLS4-2 | PMLS4-2 | PMLS4-3 | PMLS4-3 | PMLS4-3 | PMLS4-3 | PMLS4-4 | PMLS4-4 | PMLS4-5 | PMLS4-5 | PMLS4-6 | PMLS4-7 | PMLS5-1 | PMLS5-1 | PMLS5-2 | PMLS5-2 | PMLS5-3 | | |
|----------------------------|----------------|----------------|---------------|---------------|---------------|---------------|---------------|---------------|---------------|----------------|---------------|----------------|----------------|---------------|---------------|----------------|---------------|---------------|--------------|--------------|--|
| Sampling Date | 8/1/2016 | 3/10/2015 | 12/2/2015 | 8/1/2016 | 3/10/2015 | 12/2/2015 | 8/1/2016 | 3/10/2015 | 12/2/2015 | 8/1/2016 | 3/10/2015 | 12/2/2015 | 3/11/2015 | 3/11/2015 | 3/12/2015 | 12/2/2015 | 3/12/2015 | 12/2/2015 | 3/12/2015 | | |
| VOCs (GC/MS) | µg/L | µg/L | µg/L | µg/L | µg/L | µg/L | µg/L | µg/L | µg/L | µg/L | µg/L | µg/L | µg/L | µg/L | µg/L | µg/L | µg/L | µg/L | µg/L | | |
| dichlorodifluoromethane | 42.0 U | 21.0 U | 5.0 U | 5.0 U | 5.0 U | 5.0 U | 5.0 U | 5.0 U | 5.0 U | 21.0 U | 5.0 U | 21.0 U | 5.0 U | 21.0 U | 21.0 U | 21.0 U | 42.0 U | 21.0 U | 5.0 U | 5.0 U | |
| chloromethane | 42.0 U | 21.0 U | 5.0 U | 5.0 U | 5.0 U | 5.0 U | 5.0 U | 5.0 U | 5.0 U | 21.0 U | 5.0 U | 21.0 U | 5.0 U | 21.0 U | 21.0 U | 21.0 U | 42.0 U | 21.0 U | 5.0 U | 5.0 U | |
| vinyl chloride | 2840 D | 564 D | 701 D | 210 D | 28.0 D | 226 D | 204 D | 38.5 D | 412 D | 266 D | 373 D | 126 D | 695 D | 3270 D | 4220 D | 173 D | 88.5 D | 10.6 D | | | |
| bromomethane | 42.0 U | 21.0 U | 5.0 U | 5.0 U | 5.0 U | 5.0 U | 5.0 U | 5.0 U | 5.0 U | 21.0 U | 5.0 U | 21.0 U | 5.0 U | 21.0 U | 21.0 U | 21.0 U | 42.0 U | 21.0 U | 5.0 U | 5.0 U | |
| chloroethane | 42.0 U | 21.0 U | 5.0 U | 5.0 U | 5.0 U | 5.0 U | 5.0 U | 5.0 U | 5.0 U | 21.0 U | 5.0 U | 21.0 U | 5.0 U | 21.0 U | 21.0 U | 21.0 U | 42.0 U | 21.0 U | 5.0 U | 5.0 U | |
| trichlorofluoromethane | 42.0 U | 21.0 U | 5.0 U | 5.0 U | 5.0 U | 5.0 U | 5.0 U | 5.0 U | 5.0 U | 21.0 U | 5.0 U | 21.0 U | 5.0 U | 21.0 U | 21.0 U | 21.0 U | 42.0 U | 21.0 U | 5.0 U | 5.0 U | |
| 1,1-dichloroethylene | 10.8 D | 3.1 JD | 38.9 D | 25.4 D | 5.0 U | 5.0 U | 1.4 J | 2.00 J | 21.0 U | 5.0 U | 3.4 JD | 2.3 J | 21.0 U | 2.5 JD | 54.8 D | 49.4 D | 23.6 D | 18.7 D | 5.0 U | | |
| methylene chloride | 178 D | 21.0 U | 5.0 U | 5.0 U | 5.0 U | 5.0 U | 5.0 U | 5.0 U | 5.0 U | 21.0 U | 5.0 U | 21.0 U | 5.0 U | 21.0 U | 21.0 U | 21.0 U | 42.0 U | 21.0 U | 5.0 U | 5.0 U | |
| trans-1,2-dichloroethylene | 137 D | 29.3 D | 9.5 D | 5.32 D | 3.0 J | 0.7 J | 5.0 U | 8.1 JD | 6.7 D | 41.4 D | 19.6 D | 20.5 JD | 158 D | 205 D | 154 D | 17.9 JD | 38.0 D | 5.0 U | 5.0 U | | |
| 1,1-dichloroethane | 42.0 U | 21.0 U | 5.0 U | 2.85 J | 5.0 U | 5.0 U | 5.0 U | 1.23 J | 21.0 U | 5.0 U | 21.0 U | 5.0 U | 21.0 U | 21.0 U | 21.0 U | 21.0 U | 42.0 U | 2.8 JD | 3.3 J | 0.6 J | |
| 2,2-dichloropropane | 42.0 U | 21.0 U | 5.0 U | 5.0 U | 5.0 U | 5.0 U | 5.0 U | 5.0 U | 5.0 U | 21.0 U | 5.0 U | 21.0 U | 5.0 U | 21.0 U | 21.0 U | 21.0 U | 42.0 U | 21.0 U | 5.0 U | 5.0 U | |
| cis 1,2-dichloroethylene | 3080 D | 382 D | 963 D | 463 D | 17.4 D | 92.7 D | 92.2 D | 104 D | 126 D | 837 D | 855 D | 253 D | 1470 D | 7270 D | 6200 D | 1570 D | 1110 D | 7.0 D | | | |
| bromochloromethane | 42.0 U | 21.0 U | 5.0 U | 5.0 U | 5.0 U | 5.0 U | 5.0 U | 5.0 U | 5.0 U | 21.0 U | 5.0 U | 21.0 U | 5.0 U | 21.0 U | 21.0 U | 21.0 U | 42.0 U | 21.0 U | 5.0 U | 5.0 U | |
| chloroform | 42.0 U | 21.0 U | 5.0 U | 5.0 U | 5.0 U | 5.0 U | 5.0 U | 5.0 U | 5.0 U | 21.0 U | 5.0 U | 21.0 U | 5.0 U | 21.0 U | 21.0 U | 21.0 U | 42.0 U | 21.0 U | 5.0 U | 5.0 U | |
| 1,1,1-trichloroethane | 42.0 U | 21.0 U | 5.0 U | 5.0 U | 5.0 U | 5.0 U | 5.0 U | 5.0 U | 5.0 U | 21.0 U | 5.0 U | 21.0 U | 5.0 U | 21.0 U | 21.0 U | 21.0 U | 42.0 U | 21.0 U | 5.0 U | 5.0 U | |
| carbon tetrachloride | 42.0 U | 21.0 U | 5.0 U | 5.0 U | 5.0 U | 5.0 U | 5.0 U | 5.0 U | 5.0 U | 21.0 U | 5.0 U | 21.0 U | 5.0 U | 21.0 U | 21.0 U | 21.0 U | 42.0 U | 21.0 U | 5.0 U | 5.0 U | |
| 1,1-dichloropropene | 42.0 U | 21.0 U | 5.0 U | 5.0 U | 5.0 U | 5.0 U | 5.0 U | 5.0 U | 5.0 U | 21.0 U | 5.0 U | 21.0 U | 5.0 U | 21.0 U | 21.0 U | 21.0 U | 42.0 U | 21.0 U | 5.0 U | 5.0 U | |
| benzene | 42.0 U | 21.0 U | 5.0 U | 5.0 U | 5.0 U | 5.0 U | 5.0 U | 5.0 U | 5.0 U | 21.0 U | 5.0 U | 21.0 U | 5.0 U | 21.0 U | 21.0 U | 21.0 U | 42.0 U | 21.0 U | 5.0 U | 5.0 U | |
| 1,2-dichloroethane | 42.0 U | 21.0 U | 5.0 U | 5.0 U | 5.0 U | 5.0 U | 5.0 U | 5.0 U | 5.0 U | 21.0 U | 5.0 U | 21.0 U | 5.0 U | 21.0 U | 21.0 U | 21.0 U | 42.0 U | 21.0 U | 5.0 U | 5.0 U | |
| trichloroethylene | 1040 D | 16.7 JD | 26.1 D | 9.12 D | 2.2 J | 1.1 J | 1.01 J | 112 D | 72.4 D | 621 D | 354 D | 254 D | 65.5 D | 1001 D | 557 D | 285 D | 860 D | 4.0 J | | | |
| 1,2-dichloropropane | 42.0 U | 21.0 U | 5.0 U | 5.0 U | 5.0 U | 5.0 U | 5.0 U | 5.0 U | 5.0 U | 21.0 U | 5.0 U | 21.0 U | 5.0 U | 21.0 U | 21.0 U | 21.0 U | 42.0 U | 21.0 U | 5.0 U | 5.0 U | |
| dibromomethane | 42.0 U | 21.0 U | 5.0 U | 5.0 U | 5.0 U | 5.0 U | 5.0 U | 5.0 U | 5.0 U | 21.0 U | 5.0 U | 21.0 U | 5.0 U | 21.0 U | 21.0 U | 21.0 U | 42.0 U | 21.0 U | 5.0 U | 5.0 U | |
| bromodichloromethane | 42.0 U | 21.0 U | 5.0 U | 5.0 U | 5.0 U | 5.0 U | 5.0 U | 5.0 U | 5.0 U | 21.0 U | 5.0 U | 21.0 U | 5.0 U | 21.0 U | 21.0 U | 21.0 U | 42.0 U | 21.0 U | 5.0 U | 5.0 U | |
| cis-1,3-dichloropropene | 42.0 U | 21.0 U | 5.0 U | 5.0 U | 5.0 U | 5.0 U | 5.0 U | 5.0 U | 5.0 U | 21.0 U | 5.0 U | 21.0 U | 5.0 U | 21.0 U | 21.0 U | 21.0 U | 42.0 U | 21.0 U | 5.0 U | 5.0 U | |
| toluene | 42.0 U | 21.0 U | 5.0 U | 5.0 U | 5.0 U | 5.0 U | 5.0 U | 5.0 U | 5.0 U | 21.0 U | 5.0 U | 21.0 U | 5.0 U | 21.0 U | 21.0 U | 21.0 U | 42.0 U | 21.0 U | 5.0 U | 5.0 U | |
| trans-1,3-dichloropropene | 42.0 U | 21.0 U | 5.0 U | 5.0 U | 5.0 U | 5.0 U | 5.0 U | 5.0 U | 5.0 U | 21.0 U | 5.0 U | 21.0 U | 5.0 U | 21.0 U | 21.0 U | 21.0 U | 42.0 U | 21.0 U | 5.0 U | 5.0 U | |
| 1,1,2-trichloroethane | 42.0 U | 21.0 U | 5.0 U | 5.0 U | 5.0 U | 5.0 U | 5.0 U | 5.0 U | 5.0 U | 21.0 U | 5.0 U | 21.0 U | 5.0 U | 21.0 U | 21.0 U | 21.0 U | 42.0 U | 21.0 U | 5.0 U | 5.0 U | |
| tetrachloroethylene | 42.0 U | 21.0 U | 5.0 U | 5.0 U | 5.0 U | 5.0 U | 5.0 U | 5.0 U | 5.0 U | 21.0 U | 5.0 U | 21.0 U | 5.0 U | 21.0 U | 21.0 U | 21.0 U | 42.0 U | 21.0 U | 5.0 U | 5.0 U | |
| 1,3-dichloropropane | 42.0 U | 21.0 U | 5.0 U | 5.0 U | 5.0 U | 5.0 U | 5.0 U | 5.0 U | 5.0 U | 21.0 U | 5.0 U | 21.0 U | 5.0 U | 21.0 U | 21.0 U | 21.0 U | 42.0 U | 21.0 U | 5.0 U | 5.0 U | |
| dibromochloromethane | 42.0 U | 21.0 U | 5.0 U | 5.0 U | 5.0 U | 5.0 U | 5.0 U | 5.0 U | 5.0 U | 21.0 U | 5.0 U | 21.0 U | 5.0 U | 21.0 U | 21.0 U | 21.0 U | 42.0 U | 21.0 U | 5.0 U | 5.0 U | |
| 1,2-dibromoethane | 42.0 U | 21.0 U | 5.0 U | 5.0 U | 5.0 U | 5.0 U | 5.0 U | 5.0 U | 5.0 U | 21.0 U | 5.0 U | 21.0 U | 5.0 U | 21.0 U | 21.0 U | 21.0 U | 42.0 U | 21.0 U | 5.0 U | 5.0 U | |
| chlorobenzene | 15.4 JD | 17.3 JD | 9.2 D | 7.52 D | 41.7 D | 22.9 D | 15.2 D | 6.7 JD | 11.6 D | 3.2 JD | 3.3 J | 2.1 JD | 2.4 JD | 4.2 JD | 42.0 U | 7.1 JD | 3.9 J | 41.4 D | | | |
| 1,1,1,2-tetrachloroethane | 42.0 U | 21.0 U | 5.0 U | 5.0 U | 5.0 U | 5.0 U | 5.0 U | 5.0 U | 5.0 U | 21.0 U | 5.0 U | 21.0 U | 5.0 U | 21.0 U | 21.0 U | 21.0 U | 42.0 U | 21.0 U | 5.0 U | 5.0 U | |
| ethylbenzene | 42.0 U | 21.0 U | 5.0 U | 5.0 U | 5.0 U | 5.0 U | 5.0 U | 5.0 U | 5.0 U | 21.0 U | 5.0 U | 21.0 U | 5.0 U | 21.0 U | 21.0 U | 21.0 U | 42.0 U | 21.0 U | 5.0 U | 5.0 U | |
| xylenes (m/p) | 42.0 U | 21.0 U | 10.0 U | 5.0 U | 5.0 U | 10.0 U | 5.0 U | 21.0 U | 10.0 U | 42.0 U | 10.0 U | 42.0 U | 42.0 U | 42.0 U | 42.0 U | 84.0 U | 42.0 U | 10.0 U | 10.0 U | | |
| o-xylene | 42.0 U | 21.0 U | 5.0 U | 5.0 U | 5.0 U | 5.0 U | 5.0 U | 5.0 U | 5.0 U | 21.0 U | 5.0 U | 21.0 U | 5.0 U | 21.0 U | 21.0 U | 21.0 U | 42.0 U | 21.0 U | 5.0 U | 5.0 U | |
| styrene | 42.0 U | 21.0 U | 5.0 U | 5.0 U | 5.0 U | 5.0 U | 5.0 U | 5.0 U | 5.0 U | 21.0 U | 5.0 U | 21.0 U | 5.0 U | 21.0 U | 21.0 U | 21.0 U | 42.0 U | 21.0 U | 5.0 U | 5.0 U | |
| bromoform | 42.0 U | 21.0 U | 5.0 U | 5.0 U | 5.0 U | 5.0 U | 5.0 U | 5.0 U | 5.0 U | 21.0 U | 5.0 U | 21.0 U | 5.0 U | 21.0 U | 21.0 U | 21.0 U | 42.0 U | 21.0 U | 5.0 U | 5.0 U | |
| isopropyl benzene (cumene) | 42.0 U | 21.0 U | 5.0 U | 5.0 U | 5.0 U | 5.0 U | 5.0 U | 5.0 U | 5.0 U | 21.0 U | 5.0 U | 21.0 U | 5.0 U | 21.0 U | 21.0 U | 21.0 U | 42.0 U | 21.0 U | 5.0 U | 5.0 U | |
| bromobenzene | 42.0 U | 21.0 U | 5.0 U | 5.0 U | 5.0 U | 5.0 U | 5.0 U | 5.0 U | 5.0 U | 21.0 U | 5.0 U | 21.0 U | 5.0 U | 21.0 U | 21.0 U | 21.0 U | 42.0 U | 21.0 U | 5.0 U | 5.0 U | |
| 1,1,1,2-tetrachloroethane | 42.0 U | 21.0 U | 5.0 U | 5.0 U | 5.0 U | 5.0 U | 5.0 U | 5.0 U | 5.0 U | 21.0 U | 5.0 U | 21.0 U | 5.0 U | 21.0 U | 21.0 U | 21.0 U | 42.0 U | 21.0 U | 5.0 U | 5.0 U | |
| 1,2,3-trichloropropane | 42.0 U | 21.0 U | 5.0 U | 5.0 U | 5.0 U | 5.0 U | 5.0 U | 5.0 U | 5.0 U | 21.0 U | 5.0 U | 21.0 U | 5.0 U | 21.0 U | 21.0 U | 21.0 U | 42.0 U | 21.0 U | 5.0 U | 5.0 U | |
| n-propyl benzene | 42.0 U | 21.0 U | 5.0 U | 5.0 U | 5.0 U | 5.0 U | 5.0 U | 5.0 U | 5.0 U | 21.0 U | 5.0 U | 21.0 U | 5.0 U | 21.0 U | 21.0 U | 21.0 U | 42.0 U | 21.0 U | 5.0 U | 5.0 U | |
| 2-chlorotoluene | 42.0 U | 21.0 U | 5.0 U | 5.0 U | 5.0 U | 5.0 U | 5.0 U | 5.0 U | 5.0 U | 21.0 U | 5.0 U | 21.0 U | 5.0 U | 21.0 U | 21.0 U | 21.0 U | 42.0 U | 21.0 U | 5.0 U | 5.0 U | |
| 4-chlorotoluene | 42.0 U | 21.0 U | 5.0 U | 5.0 U | 5.0 U | 5.0 U | 5.0 U | 5.0 U | 5.0 U | 21.0 U | 5.0 U | 21.0 U | 5.0 U | 21.0 U | 21.0 U | 21.0 U | 42.0 U | 21.0 U | 5.0 U | 5.0 U | |
| 1,3,5-trimethylbenzene | 42.0 U | 21.0 U | 5.0 U | 5.0 U | 5.0 U | 5.0 U | 5.0 U | 5.0 U | 5.0 U | 21.0 U | 5.0 U | 21.0 U | 5.0 U | 21.0 U | 21.0 U | 21.0 U | 42.0 U | 21.0 U | 5.0 U | 5.0 U | |
| tert-butylbenzene | 42.0 U | 21.0 U | 5.0 U | 5.0 U | 5.0 U | 5.0 U | 5.0 U | 5.0 U | 5.0 U | 21.0 U | 5.0 U | 21.0 U | 5.0 U | 21.0 U | 21.0 U | 21.0 U | 42.0 U | 21.0 U | 5.0 U | 5.0 U | |
| 1,2,4-trimethylbenzene | 42.0 U | 21.0 U | 5.0 U | 5.0 U | 5.0 U | 5.0 U | 5.0 U | 5.0 U | 5.0 U | 21.0 U | 5.0 U | 21.0 U | 5.0 U | 21.0 U | 21.0 U | 21.0 U | 42.0 U | 21.0 U | 5.0 U | 5.0 U | |
| sec-butylbenzene | 42.0 U | 21.0 U | 5.0 U | 5.0 U | 5.0 U | 5.0 U | 5.0 U | 5.0 U | 5.0 U | 21.0 U | 5.0 U | 21.0 U | 5.0 U | 21.0 U | 21.0 U | 21.0 U | 42.0 U | 21.0 U | 5.0 U | 5.0 U | |
| 1,3-dichlorobenzene | 42.0 U | 21.0 U | 5.0 U | 5.0 U | 0.6 J | 5.0 U | 5.0 U | 5.0 U | 5.0 U | 21.0 U | 5.0 U | 21.0 U | 1.0 J | 21.0 U | 21.0 U | 21.0 U | 42.0 U | 21.0 U | 1.5 J | 1.0 J | |
| 4-isopropyltoluene | 42.0 U | 21.0 U | 5.0 U | 5.0 U | 5.0 U | 5.0 U | 5.0 U | 5.0 U | 5.0 U | 21.0 U | 5.0 U | 21.0 U | 5.0 U | 21.0 U | 21.0 U | 21.0 U | 42.0 U | 21.0 U | 5.0 U | 5.0 U | |
| 1,4-dichlorobenzene | 16.0 JD | 5.5 JD | 4.8 J | 4.12 J | 4.0 J | 3.1 J | 2.55 J | 5.3 JD | 4.4 J | 12.6 JD | 11.9 D | 3.5 JD | 21.0 U | 8.6 JD | 8.1 JD | 4.3 JD | 6.6 D | 5.7 D | | | |
| 1,2-dichlorobenzene | 106 D | 24.8 D | 24.6 D | 25.6 D | 11.4 D | 10.5 D | 8.24 D | 31.9 D | 32.7 D | 87.4 D | 83.0 D | 43.2 D | 11.0 JD | 92.8 D | 95.3 D | 26.7 D | 47.4 D | 14.2 D | | | |
| n-butylben | | | | | | | | | | | | | | | | | | | | | |

APPENDIX D.1: GROUNDWATER ANALYTICAL DATA SUMMARY (VOCs)

| Sample ID | PMLS5-3 | PMLS5-4 | PMLS5-4 | PMLS5-5 | PMLS5-6 | PMLS5-7 | PMLS6-1 | PMLS6-2 | PMLS6-3 | PMLS6-4 | PMLS6-5 | PMLS6-6 | PMLS6-7 | |
|-----------------------------|--------------|--------------|--------------|----------------|--------------|--------------|----------------|----------------|----------------|----------------|----------------|----------------|----------------|---------------|
| Sampling Date | 12/2/2015 | 3/12/2015 | 12/2/2015 | 3/12/2015 | 3/12/2015 | 3/12/2015 | 3/11/2015 | 3/11/2015 | 3/11/2015 | 3/12/2015 | 3/12/2015 | 3/12/2015 | 3/12/2015 | |
| VOCs (GC/MS) | µg/L | µg/L | µg/L | µg/L | µg/L | µg/L | µg/L | µg/L | µg/L | µg/L | µg/L | µg/L | µg/L | |
| dichlorodifluoromethane | 5.0 U | 5.0 U | 5.0 U | 21.0 U | 5.0 U | 5.0 U | 21.0 U | 21.0 U | 21.0 U | 21.0 U | 21.0 U | 21.0 U | 5.0 U | 21.0 U |
| chloromethane | 5.0 U | 5.0 U | 5.0 U | 21.0 U | 5.0 U | 0.5 J | 8.8 JD | 21.0 U | 21.0 U | 21.0 U | 21.0 U | 21.0 U | 5.0 U | 21.0 U |
| vinyl chloride | 223 D | 113 | 66.4 | 290 D | 15.2 | 5.0 U | 1540 D | 128 D | 79.0 D | 76.1 D | 266 D | 27.6 | 551 D | |
| bromomethane | 5.0 U | 5.0 U | 5.0 U | 21.0 U | 5.0 U | 5.0 U | 21.0 U | 21.0 U | 21.0 U | 21.0 U | 21.0 U | 21.0 U | 5.0 U | 21.0 U |
| chloroethane | 5.0 U | 5.0 U | 5.0 U | 4.5 JD | 1.2 J | 5.0 U | 21.0 U | 21.0 U | 21.0 U | 21.0 U | 21.0 U | 21.0 U | 5.0 U | 21.0 U |
| trichlorofluoromethane | 5.0 U | 5.0 U | 5.0 U | 21.0 U | 5.0 U | 5.0 U | 21.0 U | 21.0 U | 21.0 U | 21.0 U | 21.0 U | 21.0 U | 5.0 U | 21.0 U |
| 1,1-dichloroethylene | 3.8 J | 0.7 J | 5.0 U | 21.0 U | 5.0 U | 5.0 U | 14.2 JD | 12.6 JD | 6.8 JD | 21.0 U | 21.0 U | 5.0 U | 7.1 JD | |
| methylene chloride | 5.0 U | 5.0 U | 5.0 U | 21.0 U | 5.0 U | 5.0 U | 21.0 U | 21.0 U | 21.0 U | 21.0 U | 21.0 U | 21.0 U | 5.0 U | 21.0 U |
| trans-1,2-dichloroethylene | 1.9 J | 13.4 | 9.6 | 16.7 JD | 5.9 | 4.0 J | 145 D | 33.6 D | 21.0 JD | 23.3 D | 15.5 JD | 1.3 J | 53.5 D | |
| 1,1-dichloroethane | 5.0 U | 5.0 U | 5.0 U | 21.0 U | 5.0 U | 5.0 U | 21.0 U | 2.3 JD | 21.0 U | 21.0 U | 21.0 U | 5.0 U | 21.0 U | |
| 2,2-dichloropropane | 5.0 U | 5.0 U | 5.0 U | 21.0 U | 5.0 U | 5.0 U | 21.0 U | 21.0 U | 21.0 U | 21.0 U | 21.0 U | 21.0 U | 5.0 U | 21.0 U |
| cis 1,2- dichloroethylene | 155 | 211 D | 220 D | 615 D | 24.2 | 32.7 | 6650 D | 1240 D | 432 D | 171 D | 546 D | 23.0 | 3080 D | |
| bromochloromethane | 5.0 U | 5.0 U | 5.0 U | 21.0 U | 5.0 U | 5.0 U | 21.0 U | 21.0 U | 21.0 U | 21.0 U | 21.0 U | 21.0 U | 5.0 U | 21.0 U |
| chloroform | 5.0 U | 5.0 U | 5.0 U | 21.0 U | 5.0 U | 5.0 U | 21.0 U | 21.0 U | 21.0 U | 21.0 U | 21.0 U | 21.0 U | 5.0 U | 21.0 U |
| 1,1,1-trichloroethane | 5.0 U | 5.0 U | 5.0 U | 21.0 U | 5.0 U | 5.0 U | 21.0 U | 21.0 U | 21.0 U | 21.0 U | 21.0 U | 21.0 U | 5.0 U | 21.0 U |
| carbon tetrachloride | 5.0 U | 5.0 U | 5.0 U | 21.0 U | 5.0 U | 5.0 U | 21.0 U | 21.0 U | 21.0 U | 21.0 U | 21.0 U | 21.0 U | 5.0 U | 21.0 U |
| 1,1-dichloropropene | 5.0 U | 5.0 U | 5.0 U | 21.0 U | 5.0 U | 5.0 U | 21.0 U | 21.0 U | 21.0 U | 21.0 U | 21.0 U | 21.0 U | 5.0 U | 21.0 U |
| benzene | 5.0 U | 5.0 U | 5.0 U | 21.0 U | 5.0 U | 5.0 U | 21.0 U | 21.0 U | 21.0 U | 21.0 U | 21.0 U | 21.0 U | 5.0 U | 21.0 U |
| 1,2-dichloroethane | 5.0 U | 5.0 U | 5.0 U | 21.0 U | 5.0 U | 5.0 U | 21.0 U | 21.0 U | 21.0 U | 21.0 U | 21.0 U | 21.0 U | 5.0 U | 21.0 U |
| trichloroethylene | 5.7 | 74.7 | 50.0 | 82.6 D | 163 | 21.9 | 3870 D | 1800 D | 176 D | 489 D | 56.7 D | 45.4 | 2210 D | |
| 1,2-dichloropropane | 5.0 U | 5.0 U | 5.0 U | 21.0 U | 5.0 U | 5.0 U | 21.0 U | 21.0 U | 21.0 U | 21.0 U | 21.0 U | 21.0 U | 5.0 U | 21.0 U |
| dibromomethane | 5.0 U | 5.0 U | 5.0 U | 21.0 U | 5.0 U | 5.0 U | 21.0 U | 21.0 U | 21.0 U | 21.0 U | 21.0 U | 21.0 U | 5.0 U | 21.0 U |
| bromodichloromethane | 5.0 U | 5.0 U | 5.0 U | 21.0 U | 5.0 U | 5.0 U | 21.0 U | 21.0 U | 21.0 U | 21.0 U | 21.0 U | 21.0 U | 5.0 U | 21.0 U |
| cis-1,3-dichloropropene | 5.0 U | 5.0 U | 5.0 U | 21.0 U | 5.0 U | 5.0 U | 21.0 U | 21.0 U | 21.0 U | 21.0 U | 21.0 U | 21.0 U | 5.0 U | 21.0 U |
| toluene | 5.0 U | 5.0 U | 5.0 U | 21.0 U | 5.0 U | 5.0 U | 21.0 U | 21.0 U | 21.0 U | 21.0 U | 21.0 U | 21.0 U | 5.0 U | 21.0 U |
| trans-1,3-dichloropropene | 5.0 U | 5.0 U | 5.0 U | 21.0 U | 5.0 U | 5.0 U | 21.0 U | 21.0 U | 21.0 U | 21.0 U | 21.0 U | 21.0 U | 5.0 U | 21.0 U |
| 1,1,2-trichloroethane | 5.0 U | 5.0 U | 5.0 U | 21.0 U | 5.0 U | 5.0 U | 21.0 U | 21.0 U | 21.0 U | 21.0 U | 21.0 U | 21.0 U | 5.0 U | 21.0 U |
| tetrachloroethylene | 5.0 U | 5.0 U | 5.0 U | 21.0 U | 5.0 U | 5.0 U | 21.0 U | 21.0 U | 21.0 U | 21.0 U | 21.0 U | 21.0 U | 5.0 U | 21.0 U |
| 1,3-dichloropropane | 5.0 U | 5.0 U | 5.0 U | 21.0 U | 5.0 U | 5.0 U | 21.0 U | 21.0 U | 21.0 U | 21.0 U | 21.0 U | 21.0 U | 5.0 U | 21.0 U |
| dibromochloromethane | 5.0 U | 5.0 U | 5.0 U | 21.0 U | 5.0 U | 5.0 U | 21.0 U | 21.0 U | 21.0 U | 21.0 U | 21.0 U | 21.0 U | 5.0 U | 21.0 U |
| 1,2-dibromoethane | 5.0 U | 5.0 U | 5.0 U | 21.0 U | 5.0 U | 5.0 U | 21.0 U | 21.0 U | 21.0 U | 21.0 U | 21.0 U | 21.0 U | 5.0 U | 21.0 U |
| chlorobenzene | 37.1 | 16.3 | 23.2 | 2.9 JD | 1.4 J | 0.8 J | 2.4 JD | 5.3 JD | 12.2 JD | 6.0 JD | 2.6 JD | 5.0 U | 21.0 U | |
| 1,1,1,2-tetrachloroethane | 5.0 U | 5.0 U | 5.0 U | 21.0 U | 5.0 U | 5.0 U | 21.0 U | 21.0 U | 21.0 U | 21.0 U | 21.0 U | 21.0 U | 5.0 U | 21.0 U |
| ethylbenzene | 5.0 U | 5.0 U | 5.0 U | 21.0 U | 5.0 U | 5.0 U | 21.0 U | 21.0 U | 21.0 U | 21.0 U | 21.0 U | 21.0 U | 5.0 U | 21.0 U |
| xylenes (m/p) | 10.0 U | 10.0 U | 10.0 U | 42.0 U | 10.0 U | 10.0 U | 42.0 U | 42.0 U | 42.0 U | 42.0 U | 42.0 U | 42.0 U | 10.0 U | 42.0 U |
| o-xylene | 5.0 U | 5.0 U | 5.0 U | 21.0 U | 5.0 U | 5.0 U | 21.0 U | 21.0 U | 21.0 U | 21.0 U | 21.0 U | 21.0 U | 5.0 U | 21.0 U |
| styrene | 5.0 U | 5.0 U | 5.0 U | 21.0 U | 5.0 U | 5.0 U | 21.0 U | 21.0 U | 21.0 U | 21.0 U | 21.0 U | 21.0 U | 5.0 U | 21.0 U |
| bromoform | 5.0 U | 5.0 U | 5.0 U | 21.0 U | 5.0 U | 5.0 U | 21.0 U | 21.0 U | 21.0 U | 21.0 U | 21.0 U | 21.0 U | 5.0 U | 21.0 U |
| isopropyl benzene (cumene) | 5.0 U | 5.0 U | 5.0 U | 21.0 U | 5.0 U | 5.0 U | 21.0 U | 21.0 U | 21.0 U | 21.0 U | 21.0 U | 21.0 U | 5.0 U | 21.0 U |
| bromobenzene | 5.0 U | 5.0 U | 5.0 U | 21.0 U | 5.0 U | 5.0 U | 21.0 U | 21.0 U | 21.0 U | 21.0 U | 21.0 U | 21.0 U | 5.0 U | 21.0 U |
| 1,1,1,2-tetrachloroethane | 5.0 U | 5.0 U | 5.0 U | 21.0 U | 5.0 U | 5.0 U | 21.0 U | 21.0 U | 21.0 U | 21.0 U | 21.0 U | 21.0 U | 5.0 U | 21.0 U |
| 1,2,3-trichloropropane | 5.0 U | 5.0 U | 5.0 U | 21.0 U | 5.0 U | 5.0 U | 21.0 U | 21.0 U | 21.0 U | 21.0 U | 21.0 U | 21.0 U | 5.0 U | 21.0 U |
| n-propyl benzene | 5.0 U | 5.0 U | 5.0 U | 21.0 U | 5.0 U | 5.0 U | 21.0 U | 21.0 U | 21.0 U | 21.0 U | 21.0 U | 21.0 U | 5.0 U | 21.0 U |
| 2-chlorotoluene | 5.0 U | 5.0 U | 5.0 U | 21.0 U | 5.0 U | 5.0 U | 21.0 U | 21.0 U | 21.0 U | 21.0 U | 21.0 U | 21.0 U | 5.0 U | 21.0 U |
| 4-chlorotoluene | 5.0 U | 5.0 U | 5.0 U | 21.0 U | 5.0 U | 5.0 U | 21.0 U | 21.0 U | 21.0 U | 21.0 U | 21.0 U | 21.0 U | 5.0 U | 21.0 U |
| 1,3,5-trimethylbenzene | 5.0 U | 5.0 U | 5.0 U | 21.0 U | 5.0 U | 5.0 U | 21.0 U | 21.0 U | 21.0 U | 21.0 U | 21.0 U | 21.0 U | 5.0 U | 21.0 U |
| tert-butylbenzene | 5.0 U | 5.0 U | 5.0 U | 21.0 U | 5.0 U | 5.0 U | 21.0 U | 21.0 U | 21.0 U | 21.0 U | 21.0 U | 21.0 U | 5.0 U | 21.0 U |
| 1,2,4-trimethylbenzene | 5.0 U | 5.0 U | 5.0 U | 21.0 U | 5.0 U | 5.0 U | 21.0 U | 21.0 U | 21.0 U | 21.0 U | 21.0 U | 21.0 U | 5.0 U | 21.0 U |
| sec-butylbenzene | 5.0 U | 5.0 U | 5.0 U | 21.0 U | 5.0 U | 5.0 U | 21.0 U | 21.0 U | 21.0 U | 21.0 U | 21.0 U | 21.0 U | 5.0 U | 21.0 U |
| 1,3-dichlorobenzene | 2.1 J | 0.8 J | 5.0 U | 21.0 U | 5.0 U | 5.0 U | 21.0 U | 2.5 JD | 4.2 JD | 3.0 JD | 21.0 U | 5.0 U | 21.0 U | |
| 4-isopropyltoluene | 5.0 U | 5.0 U | 5.0 U | 21.0 U | 5.0 U | 5.0 U | 21.0 U | 21.0 U | 21.0 U | 21.0 U | 21.0 U | 21.0 U | 5.0 U | 21.0 U |
| 1,4-dichlorobenzene | 12.2 | 6.7 | 5.8 | 21.0 U | 1.6 J | 5.0 U | 3.4 JD | 9.4 JD | 25.1 D | 20.5 JD | 3.7 JD | 0.5 J | 21.0 U | |
| 1,2-dichlorobenzene | 90.2 | 46.6 | 36.1 | 12.6 JD | 19.6 | 3.3 J | 41.5 D | 62.7 D | 198 D | 126 D | 28.8 D | 5.0 J | 11.9 JD | |
| n-butylbenzene | 5.0 U | 5.0 U | 5.0 U | 21.0 U | 5.0 U | 5.0 U | 21.0 U | 21.0 U | 21.0 U | 21.0 U | 21.0 U | 21.0 U | 5.0 U | 21.0 U |
| 1,2-dibromo-3-chloropropane | 5.0 U | 5.0 U | 5.0 U | 21.0 U | 5.0 U | 5.0 U | 21.0 U | 21.0 U | 21.0 U | 21.0 U | 21.0 U | 21.0 U | 5.0 U | 21.0 U |
| 1,2,4-trichlorobenzene | 5.0 U | 5.0 U | 5.0 U | 21.0 U | 5.0 U | 5.0 U | 21.0 U | 21.0 U | 21.0 U | 21.0 U | 21.0 U | 21.0 U | 5.0 U | 21.0 U |
| hexachlorobutadiene | 5.0 U | 5.0 U | 5.0 U | 21.0 U | 5.0 U | 5.0 U | 21.0 U | 21.0 U | 21.0 U | 21.0 U | 21.0 U | 21.0 U | 5.0 U | 21.0 U |
| naphthalene | 5.0 U | 5.0 U | 5.0 U | 21.0 U | 5.0 U | 5.0 U | 21.0 U | 3.4 JD | 21.0 U | 21.0 U | 21.0 U | 21.0 U | 5.0 U | 21.0 U |
| 1,2,3-trichlorobenzene | 5.0 U | 5.0 U | 5.0 U | 21.0 U | 5.0 U | 5.0 U | 21.0 U | 3.0 JD | 21.0 U | 21.0 U | 21.0 U | 21.0 U | 5.0 U | 21.0 U |
| Methyl tertiary butyl ether | 5.0 U | 5.0 U | 5.0 U | 21.0 U | 5.0 U | 5.0 U | 21.0 U | 21.0 U | 21.0 U | 21.0 U | 21.0 U | 21.0 U | 5.0 U | 21.0 U |
| Acetone | 10.0 U | 10.0 U | 10.0 U | 42.0 U | 10.0 U | 10.0 U | 3.0 JD | 42.0 U | 42.0 U | 42.0 U | 42.0 U | 42.0 U | 10.0 U | 42.0 U |
| carbon disulfide | 5.0 U | 5.0 U | 5.0 U | 21.0 U | 5.0 U | 0.7 J | 21.0 U | 21.0 U | 21.0 U | 21.0 U | 21.0 U | 21.0 U | 5.0 U | 9.5 JD |
| 2-butanone (MEK) | 10.0 U | 10.0 U | 10.0 U | 42.0 U | 10.0 U | 10.0 U | 42.0 U | 42.0 U | 42.0 U | 42.0 U | 42.0 U | 42.0 U | 10.0 U | 42.0 U |
| tetrahydrofuran (THF) | 10.0 U | 21.0 | 10.0 U | 16.5 JD | 10.0 U | 10.0 U | 8.1 JD | 42.0 U | 42.0 U | 42.0 U | 42.0 U | 25.1 JD | 3.5 J | 42.0 U |
| 4-methyl-2-pentanone (MIBK) | 10.0 U | 10.0 U | 10.0 U | 42.0 U | 10.0 U | 10.0 U | 42.0 U | 42.0 U | 42.0 U | 42.0 U | 42.0 U | 42.0 U | 10.0 U | 42.0 U |
| 2-hexanone | 10.0 U | 10.0 U | 10.0 U | 42.0 U | 10.0 U | 10.0 U | 42.0 U | 42.0 U | 42.0 U | 42.0 U | 42.0 U | 42.0 U | 10.0 U | 42.0 U |
| 2-chloroethyl vinyl ether | 10.0 U | 10.0 U | 10.0 U | 42.0 U | 10.0 U | 10.0 U | 42.0 U | 42.0 U | 42.0 U | 42.0 U | 42.0 U | 42.0 U | 10.0 U | 42.0 U |

Notes:
BOLD value indicates the compound was detected above the reporting limit.
 U indicates the compound was not detected at the indicated concentration.
 J indicates the presence of a compound that meets the identification criteria. The result is less than the quantitation limit but greater than zero, and is given an approximate value.
 -- indicates analysis was not performed
 D indicates the sample was diluted prior to analysis

APPENDIX D.2: GROUNDWATER ANALYTICAL DATA SUMMARY (MICROBIAL COMMUNITY AND CSIA)

| Sample ID | MW360-5 | MW360-5 | MW360-5 | SIW01 | SIW01 | SIW02 | SIW02 | SIW02 | SIW03 | SIW03 | SMLS1-1 | SMLS1-1 | SMLS1-1 | | |
|-----------------------------------|----------------|-------------------|----------------|-----------------|----------------|----------------|----------------|----------------|-------------------|-----------------|----------------|----------------|-------------------|----------------|-----------------|
| Sampling Date | 3/17/2015 | 12/9/2015 | 8/11/2016 | 3/16/2015 | 12/8/2015 | 3/16/2015 | 12/8/2015 | 8/11/2016 | 3/16/2015 | 12/8/2015 | 3/17/2015 | 12/3/2015 | 8/11/2016 | | |
| MICROBIAL COMMUNITY | cells/mL | cells/mL | cells/mL | cells/mL | cells/mL | cells/mL | cells/mL | cells/mL | cells/mL | cells/mL | cells/mL | cells/mL | cells/mL | | |
| Reductive Dechlorination | | | | | | | | | | | | | | | |
| <i>Dehalococcoides</i> spp. | DHC | 8.09E+01 | -- | 1.10E+00 | -- | -- | -- | -- | 9.23E+06 | 2.83E+06 | -- | -- | 9.54E+04 | -- | 5.12E+04 |
| tceA Reductase | TCE | 2.80E+00 | -- | -- | -- | -- | -- | -- | 2.83E+05 | -- | -- | -- | 3.48E+03 | -- | 4.63E+03 |
| BAV1 Vinyl Chloride Reductase | BVC | 9.00E-01 U | -- | -- | -- | -- | -- | -- | 1.95E+03 | -- | -- | -- | 6.67E+01 | -- | 4.47E+02 |
| Vinyl Chloride Reductase | VCR | 5.00E-01 J | -- | -- | -- | -- | -- | -- | 3.56E+06 | -- | -- | -- | 6.23E+04 | -- | 2.89E+04 |
| <i>Dehalobacter</i> spp. | DHBt | 2.39E+02 | -- | -- | -- | -- | -- | -- | 3.07E+02 | -- | -- | -- | 1.53E+03 | -- | 1.21E+03 |
| <i>Dehalobacter</i> DCM | DCM | 9.10E+00 U | -- | -- | -- | -- | -- | -- | 5.00E+01 U | -- | -- | -- | 5.10E+00 U | -- | 4.60E+00 U |
| <i>Dehalogenimonas</i> spp. | DHG | 2.04E+03 | -- | -- | -- | -- | -- | -- | 1.73E+06 | -- | -- | -- | 2.58E+05 | -- | 2.38E+05 |
| <i>Desulfitobacterium</i> spp. | DSB | 7.47E+01 | -- | -- | -- | -- | -- | -- | 4.11E+02 | -- | -- | -- | 4.25E+03 | -- | 6.58E+03 |
| <i>Dehalobium chlorocoercia</i> | DECO | 9.10E+00 U | -- | -- | -- | -- | -- | -- | 3.88E+04 | -- | -- | -- | 5.10E+00 U | -- | 1.05E+04 |
| <i>Desulfuromonas</i> spp. | DSM | 1.24E+03 | -- | -- | -- | -- | -- | -- | 5.00E+01 U | -- | -- | -- | 5.25E+02 | -- | 7.51E+03 |
| Chloroform reductase | CFR | 2.27E+02 | -- | -- | -- | -- | -- | -- | 5.00E+01 U | -- | -- | -- | 5.10E+00 U | -- | 4.60E+00 U |
| 1,1-DCA Reductase | DCA | 9.10E+00 U | -- | -- | -- | -- | -- | -- | 5.00E+01 U | -- | -- | -- | 5.10E+00 U | -- | 4.60E+00 U |
| 1,2-DCA Reductase | DCAR | 9.10E+00 U | -- | -- | -- | -- | -- | -- | 5.00E+01 U | -- | -- | -- | 5.10E+00 U | -- | 4.60E+00 U |
| Aerobic Cometabolic | | | | | | | | | | | | | | | |
| Soluble Methane Monooxygenase | SMMO | 6.41E+03 | -- | -- | -- | -- | -- | -- | 4.11E+04 | -- | -- | -- | 1.65E+04 | -- | 2.21E+03 |
| Particulate Methane Monooxygenase | PMMO | 1.99E+02 | -- | -- | -- | -- | -- | -- | 5.97E+04 | -- | -- | -- | 5.61E+02 | -- | 4.49E+03 |
| Toluene Dioxygenase | TOD | 4.57E+02 | -- | -- | -- | -- | -- | -- | 1.92E+03 | -- | -- | -- | 3.66E+02 | -- | 6.06E+02 |
| Phenol Hydroxylase | PHE | 1.02E+03 | -- | -- | -- | -- | -- | -- | 2.11E+01 J | -- | -- | -- | 9.07E+02 | -- | 2.21E+04 |
| Trichlorobenzene Dioxygenase | TCBO | 9.10E+00 U | -- | -- | -- | -- | -- | -- | 5.00E+01 U | -- | -- | -- | 2.03E+02 | -- | 1.66E+03 |
| Toluene Monooxygenase 2 | RDEG | 4.09E+02 | -- | -- | -- | -- | -- | -- | 5.00E+01 U | -- | -- | -- | 2.51E+02 | -- | 4.81E+02 |
| Toluene Monooxygenase | RMO | 8.00E-01 J | -- | -- | -- | -- | -- | -- | 5.00E+01 U | -- | -- | -- | 3.50E+00 J | -- | 1.13E+03 |
| Ethene Monooxygenase | EtnC | 9.10E+00 U | -- | -- | -- | -- | -- | -- | 5.00E+01 U | -- | -- | -- | 1.29E+03 | -- | 5.54E+03 |
| Epoxyalkane transferase | EtnE | 9.10E+00 U | -- | -- | -- | -- | -- | -- | 5.00E+01 U | -- | -- | -- | 2.41E+04 | -- | 4.23E+03 |
| Dichloromethane dehalogenase | DCMA | 9.10E+00 U | -- | -- | -- | -- | -- | -- | 5.00E+01 U | -- | -- | -- | 5.10E+00 U | -- | 4.60E+00 U |
| Other | | | | | | | | | | | | | | | |
| Total Eubacteria | EBAC | 3.28E+05 | -- | -- | -- | -- | -- | -- | 4.49E+07 | -- | -- | -- | 2.40E+06 | -- | 4.81E+06 |
| Sulfate Reducing Bacteria | APS | 2.38E+04 | -- | -- | -- | -- | -- | -- | 9.57E+05 | -- | -- | -- | 5.14E+05 | -- | 2.72E+06 |
| Methanogens | MGN | 1.78E+02 | -- | -- | -- | -- | -- | -- | 4.45E+05 | -- | -- | -- | 1.61E+03 | -- | 3.01E+01 |
| CSIA | | | | | | | | | | | | | | | |
| | $\delta^{13}C$ | $\delta^{13}C$ | $\delta^{13}C$ | $\delta^{13}C$ | $\delta^{13}C$ | $\delta^{13}C$ | $\delta^{13}C$ | $\delta^{13}C$ | $\delta^{13}C$ | $\delta^{13}C$ | $\delta^{13}C$ | $\delta^{13}C$ | $\delta^{13}C$ | $\delta^{13}C$ | $\delta^{13}C$ |
| Vinyl Chloride | -15.39 J* | U* | -29.33 | -- | -- | -- | -- | U* | -- | -- | -13.14 | -11.88 | -23.2 | | |
| cis-1,2-dichloroethene | -12.60 | -25.92 | -25.97 | -- | -- | -- | -- | U* | -- | -- | -3.89 | 0.07 | -6.3 | | |
| Trichloroethene | -20.47 | -20.25 | -19.10 | -- | -- | -- | -- | U* | -- | -- | -20.42 | U* | -19.6 | | |

Notes:

BOLD value indicates the compound was detected above the reporting limit.

U indicates the compound was not detected at the indicated concentration.

J indicates the presence of a compound that meets the identification criteria. The result is less than the quantitation limit but greater than zero, and is given an approximate value.

-- indicates analysis was not performed

J*(CSIA): Target analyte produced a low weak signal; the result is considered usable to +/- 2 o/oo but not the standard +/- 0.5 o/oo

U* (CSIA): Either there was no peak corresponding to the target analyte or that such a peak did not produce a reliable CSIA result.

APPENDIX D.2: GROUNDWATER ANALYTICAL DATA SUMMARY (MICROBIAL COMMUNITY AND CSIA)

| Sample ID | | SMLS1-2 | SMLS1-2 | SMLS1-2 | SMLS1-3 | SMLS1-3 | SMLS1-3 | SMLS1-4 | SMLS1-4 | SMLS1-4 | SMLS1-5 | SMLS1-5 | SMLS1-5 | SMLS1-6 |
|-----------------------------------|------|-----------------------|-----------------------|-----------------------|-----------------------|-----------------------|-----------------------|-----------------------|-----------------------|-----------------------|-----------------------|-----------------------|-----------------------|-----------------------|
| Sampling Date | | 3/18/2015 | 12/3/2015 | 8/11/2016 | 3/17/2015 | 12/3/2015 | 8/11/2016 | 3/18/2015 | 12/3/2015 | 8/11/2016 | 3/18/2015 | 12/3/2015 | 8/11/2016 | 3/17/2015 |
| MICROBIAL COMMUNITY | | cells/mL | cells/mL | cells/mL | cells/mL | cells/mL | cells/mL | cells/mL | cells/mL | cells/mL | cells/mL | cells/mL | cells/mL | cells/mL |
| Reductive Dechlorination | | | | | | | | | | | | | | |
| <i>Dehalococcoides</i> spp. | DHC | -- | -- | 1.45E+05 | 2.70E+05 | -- | 2.52E+05 | -- | -- | 5.66E+04 | -- | -- | 2.06E+04 | 1.26E+05 |
| tceA Reductase | TCE | -- | -- | 1.44E+04 | 2.04E+04 | -- | 3.57E+04 | -- | -- | 4.89E+03 | -- | -- | 1.39E+03 | 4.46E+03 |
| BAV1 Vinyl Chloride Reductase | BVC | -- | -- | 1.35E+03 | 8.15E+02 | -- | 2.86E+03 | -- | -- | 4.13E+02 | -- | -- | 2.81E+03 | 4.60E+00 |
| Vinyl Chloride Reductase | VCR | -- | -- | 1.02E+05 | 7.34E+04 | -- | 6.93E+04 | -- | -- | 2.13E+04 | -- | -- | 6.46E+03 | 2.87E+04 |
| <i>Dehalobacter</i> spp. | DHBt | -- | -- | 1.92E+03 | 3.26E+04 | -- | 3.43E+03 | -- | -- | 1.42E+03 | -- | -- | 2.58E+01 | 2.68E+04 |
| <i>Dehalobacter</i> DCM | DCM | -- | -- | 4.60E+00 U | 4.70E+00 U | -- | 4.70E+00 U | -- | -- | 4.60E+00 U | -- | -- | 4.60E+00 U | 1.28E+01 |
| <i>Dehalogenimonas</i> spp. | DHG | -- | -- | 4.22E+05 | 3.14E+05 | -- | 7.72E+05 | -- | -- | 1.13E+05 | -- | -- | 3.76E+04 | 1.26E+05 |
| <i>Desulfitobacterium</i> spp. | DSB | -- | -- | 1.08E+04 | 1.39E+04 | -- | 1.91E+04 | -- | -- | 2.35E+03 | -- | -- | 8.99E+01 | 5.27E+03 |
| <i>Dehalobium chlorocoercia</i> | DECO | -- | -- | 3.53E+03 | 4.70E+00 U | -- | 2.04E+03 | -- | -- | 2.99E+03 | -- | -- | 7.67E+02 | 4.90E+00 U |
| <i>Desulfuromonas</i> spp. | DSM | -- | -- | 1.20E+05 | 1.27E+05 | -- | 1.18E+05 | -- | -- | 5.44E+03 | -- | -- | 3.65E+02 | 6.79E+03 |
| Chloroform reductase | CFR | -- | -- | 4.60E+00 U | 4.70E+00 U | -- | 4.70E+00 U | -- | -- | 4.60E+00 U | -- | -- | 4.60E+00 U | 6.23E+01 |
| 1,1-DCA Reductase | DCA | -- | -- | 4.60E+00 U | 4.70E+00 U | -- | 4.70E+00 U | -- | -- | 4.60E+00 U | -- | -- | 4.60E+00 U | 4.90E+00 U |
| 1,2-DCA Reductase | DCAR | -- | -- | 4.60E+00 U | 4.70E+00 U | -- | 4.70E+00 U | -- | -- | 4.60E+00 U | -- | -- | 4.60E+00 U | 4.90E+00 U |
| Aerobic Cometabolic | | | | | | | | | | | | | | |
| Soluble Methane Monooxygenase | SMMO | -- | -- | 2.12E+03 | 2.40E+03 | -- | 2.57E+02 | -- | -- | 1.55E+02 | -- | -- | 3.00E+02 | 2.82E+03 |
| Particulate Methane Monooxygenase | PMMO | -- | -- | 7.19E+03 | 4.24E+02 | -- | 3.11E+02 | -- | -- | 3.52E+03 | -- | -- | 1.71E+03 | 1.92E+02 |
| Toluene Dioxygenase | TOD | -- | -- | 1.47E+02 | 1.39E+02 | -- | 1.30E+03 | -- | -- | 1.52E+03 | -- | -- | 1.06E+03 | 6.79E+02 |
| Phenol Hydroxylase | PHE | -- | -- | 9.05E+02 | 4.57E+02 | -- | 4.21E+02 | -- | -- | 1.84E+02 | -- | -- | 3.84E+01 | 3.54E+02 |
| Trichlorobenzene Dioxygenase | TCBO | -- | -- | 8.65E+02 | 2.66E+01 | -- | 2.44E+02 | -- | -- | 1.98E+01 | -- | -- | 1.91E+02 | 2.80E+02 |
| Toluene Monooxygenase 2 | RDEG | -- | -- | 5.20E+01 | 1.94E+02 | -- | 1.35E+02 | -- | -- | 4.60E+00 U | -- | -- | 3.92E+01 | 1.81E+02 |
| Toluene Monooxygenase | RMO | -- | -- | 4.60E+00 U | 5.00E-01 J | -- | 4.70E+00 U | -- | -- | 4.60E+00 U | -- | -- | 4.60E+00 U | 3.60E+00 J |
| Ethene Monooxygenase | EtnC | -- | -- | 2.77E+02 | 2.56E+02 | -- | 5.64E+02 | -- | -- | 8.36E+02 | -- | -- | 7.42E+01 | 5.70E+02 |
| Epoxyalkane transferase | EtnE | -- | -- | 1.79E+02 | 1.86E+01 | -- | 1.60E+02 | -- | -- | 5.60E+02 | -- | -- | 1.08E+02 | 1.93E+01 |
| Dichloromethane dehalogenase | DCMA | -- | -- | 4.60E+00 U | 4.70E+00 U | -- | 4.70E+00 U | -- | -- | 4.60E+00 U | -- | -- | 4.60E+00 U | 4.90E+00 U |
| Other | | | | | | | | | | | | | | |
| Total Eubacteria | EBAC | -- | -- | 6.53E+06 | 1.79E+06 | -- | 1.59E+07 | -- | -- | 4.58E+06 | -- | -- | 1.26E+06 | 2.83E+06 |
| Sulfate Reducing Bacteria | APS | -- | -- | 2.04E+06 | 9.38E+05 | -- | 1.87E+06 | -- | -- | 5.11E+05 | -- | -- | 4.04E+05 | 4.74E+05 |
| Methanogens | MGN | -- | -- | 2.05E+01 | 3.91E+03 | -- | 3.32E+02 | -- | -- | 1.99E+02 | -- | -- | 1.81E+02 | 7.58E+03 |
| CSIA | | | | | | | | | | | | | | |
| | | $\delta^{13}\text{C}$ | $\delta^{13}\text{C}$ | $\delta^{13}\text{C}$ | $\delta^{13}\text{C}$ | $\delta^{13}\text{C}$ | $\delta^{13}\text{C}$ | $\delta^{13}\text{C}$ | $\delta^{13}\text{C}$ | $\delta^{13}\text{C}$ | $\delta^{13}\text{C}$ | $\delta^{13}\text{C}$ | $\delta^{13}\text{C}$ | $\delta^{13}\text{C}$ |
| Vinyl Chloride | | -- | -- | -30.79 | -35.69 | -35.42 | -32.45 | -- | -- | -31.65 | -- | -- | -21.30 | -20.46 |
| cis-1,2-dichloroethene | | -- | -- | -16.18 | -19.72 | -18.89 | -18.07 | -- | -- | -14.95 | -- | -- | -4.96 | -8.29 J* |
| Trichloroethene | | -- | -- | -19.64 | -18.00 | -19.86 | -20.37 | -- | -- | U* | -- | -- | U* | -3.94 J* |

Notes:

BOLD value indicates the compound was detected above the reporting limit.

U indicates the compound was not detected at the indicated concentration.

J indicates the presence of a compound that meets the identification criteria. The result is less than the quantitation limit but greater than zero, and is given an approximate value.

-- indicates analysis was not performed

J*(CSIA): Target analyte produced a low weak signal; the result is considered usable to +/- 2 o/oo but not the standard +/- 0.5 o/oo

U* (CSIA): Either there was no peak corresponding to the target analyte or that such a peak did not produce a reliable CSIA result.

APPENDIX D.2: GROUNDWATER ANALYTICAL DATA SUMMARY (MICROBIAL COMMUNITY AND CSIA)

| Sample ID | | SMLS1-6 | SMLS1-6 | SMLS1-7 | SMLS1-7 | SMLS1-7 | SMLS2-1 | SMLS2-1 | SMLS2-1 | SMLS2-2 | SMLS2-2 | SMLS2-2 | SMLS2-3 | SMLS2-3 |
|-----------------------------------|------|----------------|-----------------|----------------|----------------|-----------------|----------------|-----------------|----------------|----------------|----------------|----------------|----------------|----------------|
| Sampling Date | | 12/3/2015 | 8/11/2016 | 3/18/2015 | 12/3/2015 | 8/11/2016 | 3/24/2015 | 12/7/2015 | 8/3/2016 | 3/24/2015 | 12/7/2015 | 8/3/2016 | 3/24/2015 | 12/7/2015 |
| MICROBIAL COMMUNITY | | cells/mL | cells/mL | cells/mL | cells/mL | cells/mL | cells/mL | cells/mL | cells/mL | cells/mL | cells/mL | cells/mL | cells/mL | cells/mL |
| Reductive Dechlorination | | | | | | | | | | | | | | |
| <i>Dehalococcoides</i> spp. | DHC | -- | 1.27E+04 | -- | -- | 9.04E+03 | -- | 5.58E+04 | -- | -- | -- | -- | -- | -- |
| tceA Reductase | TCE | -- | 1.06E+03 | -- | -- | 7.46E+02 | -- | 2.59E+03 | -- | -- | -- | -- | -- | -- |
| BAV1 Vinyl Chloride Reductase | BVC | -- | 1.10E+02 | -- | -- | 7.11E+01 | -- | 1.94E+01 | -- | -- | -- | -- | -- | -- |
| Vinyl Chloride Reductase | VCR | -- | 2.54E+03 | -- | -- | 8.74E+02 | -- | 2.34E+04 | -- | -- | -- | -- | -- | -- |
| <i>Dehalobacter</i> spp. | DHBt | -- | 7.96E+02 | -- | -- | 6.04E+02 | -- | 8.16E+02 | -- | -- | -- | -- | -- | -- |
| <i>Dehalobacter</i> DCM | DCM | -- | 5.10E+00 U | -- | -- | 9.30E+00 U | -- | 4.70E+00 U | -- | -- | -- | -- | -- | -- |
| <i>Dehalogenimonas</i> spp. | DHG | -- | 4.20E+04 | -- | -- | 9.79E+04 | -- | 8.56E+04 | -- | -- | -- | -- | -- | -- |
| <i>Desulfitobacterium</i> spp. | DSB | -- | 4.65E+03 | -- | -- | 3.02E+03 | -- | 1.83E+03 | -- | -- | -- | -- | -- | -- |
| <i>Dehalobium chlorocoercia</i> | DECO | -- | 2.54E+03 | -- | -- | 1.00E+03 | -- | 1.86E+03 | -- | -- | -- | -- | -- | -- |
| <i>Desulfuromonas</i> spp. | DSM | -- | 4.55E+03 | -- | -- | 9.30E+00 U | -- | 7.21E+03 | -- | -- | -- | -- | -- | -- |
| Chloroform reductase | CFR | -- | 5.10E+00 U | -- | -- | 9.30E+00 U | -- | 4.70E+00 U | -- | -- | -- | -- | -- | -- |
| 1,1-DCA Reductase | DCA | -- | 5.10E+00 U | -- | -- | 9.30E+00 U | -- | 4.70E+00 U | -- | -- | -- | -- | -- | -- |
| 1,2-DCA Reductase | DCAR | -- | 5.10E+00 U | -- | -- | 9.30E+00 U | -- | 4.70E+00 U | -- | -- | -- | -- | -- | -- |
| Aerobic Cometabolic | | | | | | | | | | | | | | |
| Soluble Methane Monooxygenase | SMMO | -- | 1.64E+02 | -- | -- | 3.27E+02 | -- | 7.70E+03 | -- | -- | -- | -- | -- | -- |
| Particulate Methane Monooxygenase | PMMO | -- | 2.78E+03 | -- | -- | 2.70E+04 | -- | 1.95E+04 | -- | -- | -- | -- | -- | -- |
| Toluene Dioxygenase | TOD | -- | 1.15E+02 | -- | -- | 2.09E+02 | -- | 2.25E+02 | -- | -- | -- | -- | -- | -- |
| Phenol Hydroxylase | PHE | -- | 1.02E+03 | -- | -- | 6.81E+01 | -- | 3.10E+03 | -- | -- | -- | -- | -- | -- |
| Trichlorobenzene Dioxygenase | TCBO | -- | 3.42E+01 | -- | -- | 8.96E+01 | -- | 9.34E+02 | -- | -- | -- | -- | -- | -- |
| Toluene Monooxygenase 2 | RDEG | -- | 1.16E+02 | -- | -- | 9.30E+00 U | -- | 9.76E+02 | -- | -- | -- | -- | -- | -- |
| Toluene Monooxygenase | RMO | -- | 5.10E+00 U | -- | -- | 2.44E+02 | -- | 1.12E+02 | -- | -- | -- | -- | -- | -- |
| Ethene Monooxygenase | EtnC | -- | 5.08E+02 | -- | -- | 5.35E+03 | -- | 4.27E+03 | -- | -- | -- | -- | -- | -- |
| Epoxyalkane transferase | EtnE | -- | 5.44E+02 | -- | -- | 4.22E+03 | -- | 1.20E+04 | -- | -- | -- | -- | -- | -- |
| Dichloromethane dehalogenase | DCMA | -- | 5.10E+00 U | -- | -- | 9.30E+00 U | -- | 4.70E+00 U | -- | -- | -- | -- | -- | -- |
| Other | | | | | | | | | | | | | | |
| Total Eubacteria | EBAC | -- | 5.42E+06 | -- | -- | 3.42E+06 | -- | 3.99E+06 | -- | -- | -- | -- | -- | -- |
| Sulfate Reducing Bacteria | APS | -- | 9.35E+05 | -- | -- | 9.07E+05 | -- | 5.99E+05 | -- | -- | -- | -- | -- | -- |
| Methanogens | MGN | -- | 2.94E+02 | -- | -- | 1.25E+03 | -- | 7.72E+02 | -- | -- | -- | -- | -- | -- |
| CSIA | | | | | | | | | | | | | | |
| | | $\delta^{13}C$ | $\delta^{13}C$ | $\delta^{13}C$ | $\delta^{13}C$ | $\delta^{13}C$ | $\delta^{13}C$ | $\delta^{13}C$ | $\delta^{13}C$ | $\delta^{13}C$ | $\delta^{13}C$ | $\delta^{13}C$ | $\delta^{13}C$ | $\delta^{13}C$ |
| Vinyl Chloride | | -13.76 | -28.28 | -- | -- | -11.5 | -- | -25.12 | -- | -- | -- | -- | -- | -- |
| cis-1,2-dichloroethene | | -7.87 | -8.39 | -- | -- | -10.9 | -- | 7.69 | -- | -- | -- | -- | -- | -- |
| Trichloroethene | | U* | U* | -- | -- | U* | -- | 4.39 J* | -- | -- | -- | -- | -- | -- |

Notes:

BOLD value indicates the compound was detected above the reporting limit.

U indicates the compound was not detected at the indicated concentration.

J indicates the presence of a compound that meets the identification criteria. The result is less than the quantitation limit but greater than zero, and is given an approximate value.

-- indicates analysis was not performed

J*(CSIA): Target analyte produced a low weak signal; the result is considered usable to +/- 2 o/oo but not the standard +/- 0.5 o/oo

U* (CSIA): Either there was no peak corresponding to the target analyte or that such a peak did not produce a reliable CSIA result.

APPENDIX D.2: GROUNDWATER ANALYTICAL DATA SUMMARY (MICROBIAL COMMUNITY AND CSIA)

| Sample ID | | SMLS2-3 | SMLS2-4 | SMLS2-4 | SMLS2-4 | SMLS2-5 | SMLS2-5 | SMLS2-5 | SMLS2-6 | SMLS2-7 | SMLS3-1 | SMLS3-1 | SMLS3-2 | SMLS3-2 |
|-----------------------------------|------|-----------------------|-----------------------|-----------------------|-----------------------|-----------------------|-----------------------|-----------------------|-----------------------|-----------------------|-----------------------|-----------------------|-----------------------|-----------------------|
| Sampling Date | | 8/3/2016 | 3/24/2015 | 12/7/2015 | 8/3/2016 | 3/25/2015 | 12/7/2015 | 8/3/2016 | 3/25/2015 | 3/25/2015 | 3/25/2015 | 12/7/2015 | 3/25/2015 | 12/7/2015 |
| MICROBIAL COMMUNITY | | cells/mL | cells/mL | cells/mL | cells/mL | cells/mL | cells/mL | cells/mL | cells/mL | cells/mL | cells/mL | cells/mL | cells/mL | cells/mL |
| Reductive Dechlorination | | | | | | | | | | | | | | |
| <i>Dehalococcoides</i> spp. | DHC | -- | -- | -- | -- | -- | 2.73E+03 | -- | -- | -- | -- | -- | -- | 1.18E+04 |
| tceA Reductase | TCE | -- | -- | -- | -- | -- | 1.85E+02 | -- | -- | -- | -- | -- | -- | 6.46E+02 |
| BAV1 Vinyl Chloride Reductase | BVC | -- | -- | -- | -- | -- | 1.20E+00 | -- | -- | -- | -- | -- | -- | 2.79E+02 |
| Vinyl Chloride Reductase | VCR | -- | -- | -- | -- | -- | 5.44E+03 | -- | -- | -- | -- | -- | -- | 2.60E+03 |
| <i>Dehalobacter</i> spp. | DHBt | -- | -- | -- | -- | -- | 6.07E+02 | -- | -- | -- | -- | -- | -- | 2.27E+03 |
| <i>Dehalobacter</i> DCM | DCM | -- | -- | -- | -- | -- | 4.80E+00 U | -- | -- | -- | -- | -- | -- | 4.60E+00 U |
| <i>Dehalogenimonas</i> spp. | DHG | -- | -- | -- | -- | -- | 4.04E+04 | -- | -- | -- | -- | -- | -- | 1.60E+04 |
| <i>Desulfitobacterium</i> spp. | DSB | -- | -- | -- | -- | -- | 3.60E+03 | -- | -- | -- | -- | -- | -- | 1.00E+04 |
| <i>Dehalobium chlorocoercia</i> | DECO | -- | -- | -- | -- | -- | 3.70E+03 | -- | -- | -- | -- | -- | -- | 5.82E+03 |
| <i>Desulfuromonas</i> spp. | DSM | -- | -- | -- | -- | -- | 2.53E+02 | -- | -- | -- | -- | -- | -- | 4.60E+00 U |
| Chloroform reductase | CFR | -- | -- | -- | -- | -- | 4.80E+00 U | -- | -- | -- | -- | -- | -- | 4.60E+00 U |
| 1,1-DCA Reductase | DCA | -- | -- | -- | -- | -- | 4.80E+00 U | -- | -- | -- | -- | -- | -- | 4.60E+00 U |
| 1,2-DCA Reductase | DCAR | -- | -- | -- | -- | -- | 4.80E+00 U | -- | -- | -- | -- | -- | -- | 4.60E+00 U |
| Aerobic Cometabolic | | | | | | | | | | | | | | |
| Soluble Methane Monooxygenase | SMMO | -- | -- | -- | -- | -- | 9.58E+02 | -- | -- | -- | -- | -- | -- | 1.26E+04 |
| Particulate Methane Monooxygenase | PMMO | -- | -- | -- | -- | -- | 6.41E+02 | -- | -- | -- | -- | -- | -- | 2.45E+04 |
| Toluene Dioxygenase | TOD | -- | -- | -- | -- | -- | 8.58E+01 | -- | -- | -- | -- | -- | -- | 3.34E+02 |
| Phenol Hydroxylase | PHE | -- | -- | -- | -- | -- | 1.61E+01 | -- | -- | -- | -- | -- | -- | 2.31E+02 |
| Trichlorobenzene Dioxygenase | TCBO | -- | -- | -- | -- | -- | 1.57E+02 | -- | -- | -- | -- | -- | -- | 1.08E+02 |
| Toluene Monooxygenase 2 | RDEG | -- | -- | -- | -- | -- | 4.80E+00 U | -- | -- | -- | -- | -- | -- | 2.06E+02 |
| Toluene Monooxygenase | RMO | -- | -- | -- | -- | -- | 4.80E+00 U | -- | -- | -- | -- | -- | -- | 4.60E+00 U |
| Ethene Monooxygenase | EtnC | -- | -- | -- | -- | -- | 1.00E+03 | -- | -- | -- | -- | -- | -- | 3.00E+00 J |
| Epoxyalkane transferase | EtnE | -- | -- | -- | -- | -- | 1.52E+03 | -- | -- | -- | -- | -- | -- | 4.60E+00 U |
| Dichloromethane dehalogenase | DCMA | -- | -- | -- | -- | -- | 4.80E+00 U | -- | -- | -- | -- | -- | -- | 4.60E+00 U |
| Other | | | | | | | | | | | | | | |
| Total Eubacteria | EBAC | -- | -- | -- | -- | -- | 4.11E+06 | -- | -- | -- | -- | -- | -- | 4.18E+06 |
| Sulfate Reducing Bacteria | APS | -- | -- | -- | -- | -- | 2.09E+05 | -- | -- | -- | -- | -- | -- | 2.05E+05 |
| Methanogens | MGN | -- | -- | -- | -- | -- | 1.15E+03 | -- | -- | -- | -- | -- | -- | 7.52E+03 |
| CSIA | | | | | | | | | | | | | | |
| | | $\delta^{13}\text{C}$ | $\delta^{13}\text{C}$ | $\delta^{13}\text{C}$ | $\delta^{13}\text{C}$ | $\delta^{13}\text{C}$ | $\delta^{13}\text{C}$ | $\delta^{13}\text{C}$ | $\delta^{13}\text{C}$ | $\delta^{13}\text{C}$ | $\delta^{13}\text{C}$ | $\delta^{13}\text{C}$ | $\delta^{13}\text{C}$ | $\delta^{13}\text{C}$ |
| Vinyl Chloride | | -- | -- | -- | -- | -- | 15.49 | -- | -- | -- | -- | -- | -- | U* |
| cis-1,2-dichloroethene | | -- | -- | -- | -- | -- | 21.47 | -- | -- | -- | -- | -- | -- | 31.98 |
| Trichloroethene | | -- | -- | -- | -- | -- | U* | -- | -- | -- | -- | -- | -- | U* |

Notes:

BOLD value indicates the compound was detected above the reporting limit.

U indicates the compound was not detected at the indicated concentration.

J indicates the presence of a compound that meets the identification criteria. The result is less than the quantitation limit but greater than zero, and is given an approximate value.

-- indicates analysis was not performed

J*(CSIA): Target analyte produced a low weak signal; the result is considered usable to +/- 2 o/oo but not the standard +/- 0.5 o/oo

U* (CSIA): Either there was no peak corresponding to the target analyte or that such a peak did not produce a reliable CSIA result.

APPENDIX D.2: GROUNDWATER ANALYTICAL DATA SUMMARY (MICROBIAL COMMUNITY AND CSIA)

| Sample ID | | SMLS3-3 | SMLS3-3 | SMLS3-4 | SMLS3-4 | SMLS3-5 | SMLS3-6 | SMLS3-7 | SMLS4-1 | SMLS4-1 | SMLS4-1 | SMLS4-2 | SMLS4-2 | SMLS4-2 |
|-----------------------------------|------|----------------|----------------|----------------|-------------------|----------------|----------------|----------------|----------------|------------------|-----------------|----------------|----------------|-----------------|
| Sampling Date | | 3/25/2015 | 12/7/2015 | 3/25/2015 | 12/7/2015 | 3/25/2015 | 3/25/2015 | 3/25/2015 | 3/26/2015 | 12/7/2015 | 8/2/2016 | 3/26/2015 | 12/7/2015 | 8/2/2016 |
| MICROBIAL COMMUNITY | | cells/mL | cells/mL | cells/mL | cells/mL | cells/mL | cells/mL | cells/mL | cells/mL | cells/mL | cells/mL | cells/mL | cells/mL | cells/mL |
| Reductive Dechlorination | | | | | | | | | | | | | | |
| <i>Dehalococcoides</i> spp. | DHC | -- | -- | -- | 4.58E+04 | -- | -- | -- | -- | 1.16E+06 | 6.97E+05 | -- | -- | 7.59E+05 |
| tceA Reductase | TCE | -- | -- | -- | 1.94E+03 | -- | -- | -- | -- | 4.49E+04 | 6.81E+03 | -- | -- | 1.56E+04 |
| BAV1 Vinyl Chloride Reductase | BVC | -- | -- | -- | 8.00E-01 | -- | -- | -- | -- | 1.34E+03 | 4.03E+01 | -- | -- | 5.29E+01 |
| Vinyl Chloride Reductase | VCR | -- | -- | -- | 2.71E+04 | -- | -- | -- | -- | 7.11E+05 | 1.46E+05 | -- | -- | 1.27E+05 |
| <i>Dehalobacter</i> spp. | DHBt | -- | -- | -- | 6.26E+02 | -- | -- | -- | -- | 5.37E+02 | 1.88E+02 | -- | -- | 2.18E+02 |
| <i>Dehalobacter</i> DCM | DCM | -- | -- | -- | 4.70E+00 U | -- | -- | -- | -- | 4.80E+00 U | 4.90E+00 U | -- | -- | 4.60E+00 |
| <i>Dehalogenimonas</i> spp. | DHG | -- | -- | -- | 1.25E+05 | -- | -- | -- | -- | 2.19E+06 | 2.69E+05 | -- | -- | 4.34E+05 |
| <i>Desulfitobacterium</i> spp. | DSB | -- | -- | -- | 1.69E+03 | -- | -- | -- | -- | 2.60E+03 | 7.68E+02 | -- | -- | 1.84E+03 |
| <i>Dehalobium chlorocoercia</i> | DECO | -- | -- | -- | 3.47E+03 | -- | -- | -- | -- | 3.43E+03 | 1.65E+03 | -- | -- | 3.95E+03 |
| <i>Desulfuromonas</i> spp. | DSM | -- | -- | -- | 2.72E+02 | -- | -- | -- | -- | 3.73E+05 | 3.51E+04 | -- | -- | 4.11E+04 |
| Chloroform reductase | CFR | -- | -- | -- | 4.70E+00 U | -- | -- | -- | -- | 4.80E+00 U | 4.90E+00 U | -- | -- | 4.60E+00 U |
| 1,1-DCA Reductase | DCA | -- | -- | -- | 4.70E+00 U | -- | -- | -- | -- | 4.80E+00 U | 4.90E+00 U | -- | -- | 4.60E+00 U |
| 1,2-DCA Reductase | DCAR | -- | -- | -- | 4.70E+00 U | -- | -- | -- | -- | 4.80E+00 U | 4.90E+00 U | -- | -- | 4.60E+00 U |
| Aerobic Cometabolic | | | | | | | | | | | | | | |
| Soluble Methane Monooxygenase | SMMO | -- | -- | -- | 5.89E+03 | -- | -- | -- | -- | 1.11E+04 | 1.76E+02 | -- | -- | 1.98E+03 |
| Particulate Methane Monooxygenase | PMMO | -- | -- | -- | 7.42E+02 | -- | -- | -- | -- | 2.98E+04 | 1.46E+03 | -- | -- | 9.87E+03 |
| Toluene Dioxygenase | TOD | -- | -- | -- | 5.47E+01 | -- | -- | -- | -- | 3.16E+02 | 8.05E+01 | -- | -- | 9.38E+02 |
| Phenol Hydroxylase | PHE | -- | -- | -- | 3.38E+01 | -- | -- | -- | -- | 1.23E+03 | 1.57E+02 | -- | -- | 4.45E+03 |
| Trichlorobenzene Dioxygenase | TCBO | -- | -- | -- | 4.70E+00 U | -- | -- | -- | -- | 4.80E+00 U | 4.90E+00 U | -- | -- | 3.29E+01 |
| Toluene Monooxygenase 2 | RDEG | -- | -- | -- | 4.70E+00 U | -- | -- | -- | -- | 6.79E+02 | 6.26E+01 | -- | -- | 4.67E+02 |
| Toluene Monooxygenase | RMO | -- | -- | -- | 4.70E+00 U | -- | -- | -- | -- | 4.80E+00 U | 4.90E+00 U | -- | -- | 4.60E+00 U |
| Ethene Monooxygenase | EtnC | -- | -- | -- | 9.00E-01 J | -- | -- | -- | -- | 1.15E+02 | 6.50E+00 | -- | -- | 1.74E+03 |
| Epoxyalkane transferase | EtnE | -- | -- | -- | 4.70E+00 U | -- | -- | -- | -- | 1.56E+02 | 9.10E+00 | -- | -- | 1.09E+03 |
| Dichloromethane dehalogenase | DCMA | -- | -- | -- | 4.70E+00 U | -- | -- | -- | -- | 4.80E+00 U | 4.90E+00 U | -- | -- | 4.60E+00 U |
| Other | | | | | | | | | | | | | | |
| Total Eubacteria | EBAC | -- | -- | -- | 4.01E+06 | -- | -- | -- | -- | 4.27E+06 | 1.09E+06 | -- | -- | 2.02E+06 |
| Sulfate Reducing Bacteria | APS | -- | -- | -- | 2.31E+05 | -- | -- | -- | -- | 4.22E+06 | 3.34E+05 | -- | -- | 9.83E+05 |
| Methanogens | MGN | -- | -- | -- | 1.41E+03 | -- | -- | -- | -- | 1.78E+03 | 7.55E+01 | -- | -- | 8.25E+01 |
| CSIA | | | | | | | | | | | | | | |
| | | $\delta^{13}C$ | $\delta^{13}C$ | $\delta^{13}C$ | $\delta^{13}C$ | $\delta^{13}C$ | $\delta^{13}C$ | $\delta^{13}C$ | $\delta^{13}C$ | $\delta^{13}C$ | $\delta^{13}C$ | $\delta^{13}C$ | $\delta^{13}C$ | $\delta^{13}C$ |
| Vinyl Chloride | | -- | -- | -- | -15.64 | -- | -- | -- | -- | -21.12 | -15.8 | -- | -- | -26.9 |
| cis-1,2-dichloroethene | | -- | -- | -- | 10.41 | -- | -- | -- | -- | -12.26 | -13.6 | -- | -- | -18.7 |
| Trichloroethene | | -- | -- | -- | U* | -- | -- | -- | -- | -22.24 J* | -24.0 | -- | -- | U* |

Notes:

BOLD value indicates the compound was detected above the reporting limit.

U indicates the compound was not detected at the indicated concentration.

J indicates the presence of a compound that meets the identification criteria. The result is less than the quantitation limit but greater than zero, and is given an approximate value.

-- indicates analysis was not performed

J*(CSIA): Target analyte produced a low weak signal; the result is considered usable to +/- 2 o/oo but not the standard +/- 0.5 o/oo

U* (CSIA): Either there was no peak corresponding to the target analyte or that such a peak did not produce a reliable CSIA result.

APPENDIX D.2: GROUNDWATER ANALYTICAL DATA SUMMARY (MICROBIAL COMMUNITY AND CSIA)

| Sample ID | | SMLS4-3 | SMLS4-3 | SMLS4-3 | SMLS4-4 | SMLS4-4 | SMLS4-4 | SMLS4-5 | SMLS4-5 | SMLS4-5 | SMLS4-6 | SMLS4-6 | SMLS4-7 | SMLS4-7 |
|-----------------------------------|------|----------------|----------------|-----------------|----------------|-----------------|-----------------|----------------|----------------|-----------------|----------------|-----------------|----------------|-------------------|
| Sampling Date | | 3/26/2015 | 12/7/2015 | 8/2/2016 | 3/26/2015 | 12/7/2015 | 8/2/2016 | 3/26/2015 | 12/7/2015 | 8/2/2016 | 3/26/2015 | 8/2/2016 | 3/26/2015 | 8/2/2016 |
| MICROBIAL COMMUNITY | | cells/mL | cells/mL | cells/mL | cells/mL | cells/mL | cells/mL | cells/mL | cells/mL | cells/mL | cells/mL | cells/mL | cells/mL | cells/mL |
| Reductive Dechlorination | | | | | | | | | | | | | | |
| <i>Dehalococcoides</i> spp. | DHC | -- | -- | 4.98E+05 | -- | 3.66E+05 | 1.42E+05 | -- | -- | 5.74E+05 | -- | 4.55E+04 | -- | 2.54E+05 |
| tceA Reductase | TCE | -- | -- | 8.44E+03 | -- | 1.72E+04 | 3.81E+03 | -- | -- | 7.61E+03 | -- | 1.22E+03 | -- | 1.22E+03 |
| BAV1 Vinyl Chloride Reductase | BVC | -- | -- | 3.35E+02 | -- | 2.33E+04 | 1.11E+03 | -- | -- | 2.27E+03 | -- | 9.29E+02 | -- | 1.42E+04 |
| Vinyl Chloride Reductase | VCR | -- | -- | 2.12E+05 | -- | 2.56E+05 | 7.12E+04 | -- | -- | 1.16E+05 | -- | 1.36E+04 | -- | 8.01E+04 |
| <i>Dehalobacter</i> spp. | DHBt | -- | -- | 6.70E+02 | -- | 1.01E+03 | 1.59E+03 | -- | -- | 1.12E+02 | -- | 5.22E+02 | -- | 3.99E+02 |
| <i>Dehalobacter</i> DCM | DCM | -- | -- | 4.70E+00 U | -- | 4.70E+00 U | 4.60E+00 U | -- | -- | 4.70E+00 U | -- | 4.60E+00 U | -- | 4.60E+00 U |
| <i>Dehalogenimonas</i> spp. | DHG | -- | -- | 4.80E+05 | -- | 7.04E+05 | 1.28E+05 | -- | -- | 1.81E+05 | -- | 3.60E+04 | -- | 1.05E+05 |
| <i>Desulfitobacterium</i> spp. | DSB | -- | -- | 2.16E+03 | -- | 4.49E+03 | 6.25E+02 | -- | -- | 8.21E+02 | -- | 1.25E+03 | -- | 1.32E+03 |
| <i>Dehalobium chlorocoercia</i> | DECO | -- | -- | 3.87E+03 | -- | 8.18E+03 | 3.31E+03 | -- | -- | 2.15E+03 | -- | 1.93E+03 | -- | 1.64E+03 |
| <i>Desulfuromonas</i> spp. | DSM | -- | -- | 8.33E+04 | -- | 1.55E+04 | 2.71E+03 | -- | -- | 6.59E+04 | -- | 1.44E+03 | -- | 4.81E+02 |
| Chloroform reductase | CFR | -- | -- | 4.70E+00 U | -- | 4.70E+00 U | 4.60E+00 U | -- | -- | 4.70E+00 U | -- | 4.60E+00 U | -- | 4.60E+00 U |
| 1,1-DCA Reductase | DCA | -- | -- | 4.70E+00 U | -- | 4.70E+00 U | 4.60E+00 U | -- | -- | 4.70E+00 U | -- | 4.60E+00 U | -- | 4.60E+00 U |
| 1,2-DCA Reductase | DCAR | -- | -- | 4.70E+00 U | -- | 4.70E+00 U | 4.60E+00 U | -- | -- | 4.70E+00 U | -- | 4.60E+00 U | -- | 4.60E+00 U |
| Aerobic Cometabolic | | | | | | | | | | | | | | |
| Soluble Methane Monooxygenase | SMMO | -- | -- | 2.23E+02 | -- | 1.81E+03 | 5.01E+02 | -- | -- | 3.12E+02 | -- | 3.15E+03 | -- | 2.00E+03 |
| Particulate Methane Monooxygenase | PMMO | -- | -- | 3.05E+03 | -- | 1.40E+03 | 1.60E+03 | -- | -- | 1.61E+03 | -- | 2.68E+03 | -- | 6.68E+02 |
| Toluene Dioxygenase | TOD | -- | -- | 6.92E+01 | -- | 3.30E+01 | 1.32E+02 | -- | -- | 1.34E+02 | -- | 2.89E+02 | -- | 1.87E+02 |
| Phenol Hydroxylase | PHE | -- | -- | 1.71E+04 | -- | 4.70E+00 U | 1.68E+02 | -- | -- | 3.18E+02 | -- | 4.60E+00 U | -- | 2.04E+02 |
| Trichlorobenzene Dioxygenase | TCBO | -- | -- | 4.70E+00 U | -- | 4.70E+00 U | 4.60E+00 U | -- | -- | 4.70E+00 U | -- | 4.60E+00 U | -- | 4.60E+00 U |
| Toluene Monooxygenase 2 | RDEG | -- | -- | 4.70E+00 U | -- | 4.70E+00 U | 6.06E+01 | -- | -- | 4.70E+00 U | -- | 4.60E+00 U | -- | 9.72E+02 |
| Toluene Monooxygenase | RMO | -- | -- | 4.70E+00 U | -- | 4.70E+00 U | 4.60E+00 U | -- | -- | 4.70E+00 U | -- | 4.60E+00 U | -- | 4.60E+00 U |
| Ethene Monooxygenase | EtnC | -- | -- | 7.74E+02 | -- | 3.70E+02 | 5.31E+01 | -- | -- | 4.96E+01 | -- | 7.40E+00 | -- | 6.00E-01 J |
| Epoxyalkane transferase | EtnE | -- | -- | 5.59E+02 | -- | 5.13E+03 | 5.51E+01 | -- | -- | 1.22E+01 | -- | 4.60E+00 U | -- | 4.60E+00 U |
| Dichloromethane dehalogenase | DCMA | -- | -- | 4.70E+00 U | -- | 4.70E+00 U | 4.60E+00 U | -- | -- | 4.70E+00 U | -- | 4.60E+00 U | -- | 4.60E+00 U |
| Other | | | | | | | | | | | | | | |
| Total Eubacteria | EBAC | -- | -- | 1.55E+06 | -- | 6.70E+06 | 8.65E+05 | -- | -- | 6.45E+05 | -- | 6.43E+05 | -- | 2.28E+06 |
| Sulfate Reducing Bacteria | APS | -- | -- | 1.22E+06 | -- | 5.32E+05 | 4.43E+05 | -- | -- | 6.34E+05 | -- | 4.32E+05 | -- | 7.25E+05 |
| Methanogens | MGN | -- | -- | 7.71E+03 | -- | 8.40E+03 | 5.13E+02 | -- | -- | 4.77E+02 | -- | 8.20E+02 | -- | 2.19E+03 |
| CSIA | | | | | | | | | | | | | | |
| | | $\delta^{13}C$ | $\delta^{13}C$ | $\delta^{13}C$ | $\delta^{13}C$ | $\delta^{13}C$ | $\delta^{13}C$ | $\delta^{13}C$ | $\delta^{13}C$ | $\delta^{13}C$ | $\delta^{13}C$ | $\delta^{13}C$ | $\delta^{13}C$ | $\delta^{13}C$ |
| Vinyl Chloride | | -- | -- | -24.76 | -- | -27.11 | -32.95 | -- | -- | -32.39 | -- | -13.8 | -- | -9.0 |
| cis-1,2-dichloroethene | | -- | -- | -15.87 | -- | 0.63 | -9.96 | -- | -- | -10.55 | -- | -1.1 | -- | 14.9 |
| Trichloroethene | | -- | -- | -22.30 | -- | U* | U* | -- | -- | U* | -- | U* | -- | U* |

Notes:

BOLD value indicates the compound was detected above the reporting limit.

U indicates the compound was not detected at the indicated concentration.

J indicates the presence of a compound that meets the identification criteria. The result is less than the quantitation limit but greater than zero, and is given an approximate value.

-- indicates analysis was not performed

J*(CSIA): Target analyte produced a low weak signal; the result is considered usable to +/- 2 o/oo but not the standard +/- 0.5 o/oo

U* (CSIA): Either there was no peak corresponding to the target analyte or that such a peak did not produce a reliable CSIA result.

APPENDIX D.2: GROUNDWATER ANALYTICAL DATA SUMMARY (MICROBIAL COMMUNITY AND CSIA)

| Sample ID | SMLS5-1 | SMLS5-1 | SMLS5-2 | SMLS5-2 | SMLS5-3 | SMLS5-3 | SMLS5-4 | SMLS5-4 | SMLS5-5 | SMLS5-5 | SMLS5-6 | SMLS5-6 | SMLS5-7 |
|-----------------------------------|-----------------------|-----------------------|-----------------------|-----------------------|-----------------------|-----------------------|-----------------------|-----------------------|-----------------------|-----------------------|-----------------------|-----------------------|-----------------------|
| Sampling Date | 3/17/2015 | 12/15/2015 | 3/18/2015 | 12/15/2015 | 3/17/2015 | 12/15/2015 | 3/18/2015 | 12/15/2015 | 3/18/2015 | 12/15/2015 | 3/17/2015 | 12/15/2015 | 3/18/2015 |
| MICROBIAL COMMUNITY | cells/mL | cells/mL | cells/mL | cells/mL | cells/mL | cells/mL | cells/mL | cells/mL | cells/mL | cells/mL | cells/mL | cells/mL | cells/mL |
| Reductive Dechlorination | | | | | | | | | | | | | |
| <i>Dehalococcoides</i> spp. | DHC | 3.40E+04 | 3.20E+04 | -- | -- | 1.70E+04 | -- | -- | -- | -- | 7.46E+03 | -- | -- |
| tceA Reductase | TCE | 1.44E+03 | 1.31E+03 | -- | -- | 5.30E+02 | -- | -- | -- | -- | 5.09E+02 | -- | -- |
| BAV1 Vinyl Chloride Reductase | BVC | 7.86E+01 | 1.29E+01 | -- | -- | 1.96E+01 | -- | -- | -- | -- | 3.40E+01 | -- | -- |
| Vinyl Chloride Reductase | VCR | 2.77E+03 | 4.91E+03 | -- | -- | 6.59E+02 | -- | -- | -- | -- | 4.01E+02 | -- | -- |
| <i>Dehalobacter</i> spp. | DHBt | 1.02E+03 | 1.69E+03 | -- | -- | 4.26E+03 | -- | -- | -- | -- | 7.66E+02 | -- | -- |
| <i>Dehalobacter</i> DCM | DCM | 2.50E+01 | 1.26E+01 | -- | -- | 4.70E+00 U | -- | -- | -- | -- | 4.70E+00 U | -- | -- |
| <i>Dehalogenimonas</i> spp. | DHG | 4.50E+04 | 7.14E+03 | -- | -- | 4.58E+04 | -- | -- | -- | -- | 6.02E+04 | -- | -- |
| <i>Desulfitobacterium</i> spp. | DSB | 1.77E+03 | 2.47E+03 | -- | -- | 2.94E+03 | -- | -- | -- | -- | 2.77E+03 | -- | -- |
| <i>Dehalobium chlorocoercia</i> | DECO | 4.90E+00 U | 5.82E+03 | -- | -- | 4.70E+00 U | -- | -- | -- | -- | 4.70E+00 U | -- | -- |
| <i>Desulfuromonas</i> spp. | DSM | 7.80E+03 | 4.80E+04 | -- | -- | 3.16E+03 | -- | -- | -- | -- | 2.31E+03 | -- | -- |
| Chloroform reductase | CFR | 4.90E+00 U | 4.80E+00 U | -- | -- | 4.70E+00 U | -- | -- | -- | -- | 1.60E+01 | -- | -- |
| 1,1-DCA Reductase | DCA | 4.90E+00 U | 4.80E+00 U | -- | -- | 4.70E+00 U | -- | -- | -- | -- | 4.70E+00 U | -- | -- |
| 1,2-DCA Reductase | DCAR | 4.90E+00 U | 4.80E+00 U | -- | -- | 4.70E+00 U | -- | -- | -- | -- | 4.70E+00 U | -- | -- |
| Aerobic Cometabolic | | | | | | | | | | | | | |
| Soluble Methane Monooxygenase | SMMO | 2.19E+03 | 1.12E+03 | -- | -- | 2.01E+05 | -- | -- | -- | -- | 1.36E+04 | -- | -- |
| Particulate Methane Monooxygenase | PMMO | 1.10E+03 | 5.83E+03 | -- | -- | 1.18E+04 | -- | -- | -- | -- | 2.72E+02 | -- | -- |
| Toluene Dioxygenase | TOD | 2.17E+02 | 5.86E+02 | -- | -- | 1.95E+02 | -- | -- | -- | -- | 9.95E+02 | -- | -- |
| Phenol Hydroxylase | PHE | 1.57E+03 | 4.08E+03 | -- | -- | 7.54E+02 | -- | -- | -- | -- | 1.29E+03 | -- | -- |
| Trichlorobenzene Dioxygenase | TCBO | 5.28E+01 | 6.77E+02 | -- | -- | 2.38E+01 | -- | -- | -- | -- | 4.55E+01 | -- | -- |
| Toluene Monooxygenase 2 | RDEG | 7.14E+02 | 5.51E+03 | -- | -- | 1.32E+02 | -- | -- | -- | -- | 7.67E+01 | -- | -- |
| Toluene Monooxygenase | RMO | 6.10E+00 | 4.80E+00 U | -- | -- | 1.22E+01 | -- | -- | -- | -- | 1.00E+00 J | -- | -- |
| Ethene Monooxygenase | EtnC | 7.80E+00 | 1.12E+01 | -- | -- | 4.70E+00 U | -- | -- | -- | -- | 1.00E+00 J | -- | -- |
| Epoxyalkane transferase | EtnE | 4.90E+00 U | 4.80E+00 U | -- | -- | 4.70E+00 U | -- | -- | -- | -- | 4.70E+00 U | -- | -- |
| Dichloromethane dehalogenase | DCMA | 4.90E+00 U | 4.80E+00 U | -- | -- | 4.70E+00 U | -- | -- | -- | -- | 4.70E+00 U | -- | -- |
| Other | | | | | | | | | | | | | |
| Total Eubacteria | EBAC | 1.36E+06 | 3.57E+06 | -- | -- | 1.98E+06 | -- | -- | -- | -- | 1.67E+06 | -- | -- |
| Sulfate Reducing Bacteria | APS | 3.13E+05 | 6.70E+05 | -- | -- | 7.76E+05 | -- | -- | -- | -- | 6.12E+05 | -- | -- |
| Methanogens | MGN | 4.77E+04 | 4.68E+04 | -- | -- | 3.18E+04 | -- | -- | -- | -- | 2.43E+04 | -- | -- |
| CSIA | | | | | | | | | | | | | |
| | $\delta^{13}\text{C}$ | $\delta^{13}\text{C}$ | $\delta^{13}\text{C}$ | $\delta^{13}\text{C}$ | $\delta^{13}\text{C}$ | $\delta^{13}\text{C}$ | $\delta^{13}\text{C}$ | $\delta^{13}\text{C}$ | $\delta^{13}\text{C}$ | $\delta^{13}\text{C}$ | $\delta^{13}\text{C}$ | $\delta^{13}\text{C}$ | $\delta^{13}\text{C}$ |
| Vinyl Chloride | U | -- | -- | -- | U | -- | -- | -- | -- | -- | 23.88 J* | -- | -- |
| cis-1,2-dichloroethene | -10.76 J* | -- | -- | -- | -12.93 J* | -- | -- | -- | -- | -- | U | -- | -- |
| Trichloroethene | -29.63 J* | -- | -- | -- | -23.82 J* | -- | -- | -- | -- | -- | U | -- | -- |

Notes:

BOLD value indicates the compound was detected above the reporting limit.

U indicates the compound was not detected at the indicated concentration.

J indicates the presence of a compound that meets the identification criteria. The result is less than the quantitation limit but greater than zero, and is given an approximate value.

-- indicates analysis was not performed

J*(CSIA): Target analyte produced a low weak signal; the result is considered usable to +/- 2 o/oo but not the standard +/- 0.5 o/oo

U* (CSIA): Either there was no peak corresponding to the target analyte or that such a peak did not produce a reliable CSIA result.

APPENDIX D.2: GROUNDWATER ANALYTICAL DATA SUMMARY (MICROBIAL COMMUNITY AND CSIA)

| Sample ID | | SMLS6-1 | SMLS6-2 | SMLS6-3 | SMLS6-4 | SMLS6-5 | SMLS6-6 | SMLS6-7 | SMLS7-1 | SMLS7-1 | SMLS7-1 | SMLS7-2 | SMLS7-2 | SMLS7-2 |
|-----------------------------------|------|-----------------------|-----------------------|-----------------------|-----------------------|-----------------------|-----------------------|-----------------------|-----------------------|-----------------------|-----------------------|-----------------------|-----------------------|-----------------------|
| Sampling Date | | 3/24/2015 | 3/24/2015 | 3/24/2015 | 3/24/2015 | 3/24/2015 | 3/24/2015 | 3/24/2015 | 3/17/2015 | 12/8/2015 | 8/3/2016 | 3/23/2015 | 12/8/2015 | 8/3/2016 |
| MICROBIAL COMMUNITY | | cells/mL | cells/mL | cells/mL | cells/mL | cells/mL | cells/mL | cells/mL | cells/mL | cells/mL | cells/mL | cells/mL | cells/mL | cells/mL |
| Reductive Dechlorination | | | | | | | | | | | | | | |
| <i>Dehalococcoides</i> spp. | DHC | -- | -- | -- | -- | -- | -- | -- | 6.90E+04 | -- | 5.86E+04 | -- | 8.30E+04 | -- |
| tceA Reductase | TCE | -- | -- | -- | -- | -- | -- | -- | 3.46E+03 | -- | -- | -- | 3.35E+03 | -- |
| BAV1 Vinyl Chloride Reductase | BVC | -- | -- | -- | -- | -- | -- | -- | 1.51E+03 | -- | -- | -- | 4.12E+02 | -- |
| Vinyl Chloride Reductase | VCR | -- | -- | -- | -- | -- | -- | -- | 1.89E+04 | -- | -- | -- | 4.76E+04 | -- |
| <i>Dehalobacter</i> spp. | DHBt | -- | -- | -- | -- | -- | -- | -- | 2.04E+03 | -- | -- | -- | 1.17E+03 | -- |
| <i>Dehalobacter</i> DCM | DCM | -- | -- | -- | -- | -- | -- | -- | 1.23E+01 | -- | -- | -- | 4.80E+00 U | -- |
| <i>Dehalogenimonas</i> spp. | DHG | -- | -- | -- | -- | -- | -- | -- | 7.94E+04 | -- | -- | -- | 2.09E+05 | -- |
| <i>Desulfitobacterium</i> spp. | DSB | -- | -- | -- | -- | -- | -- | -- | 2.32E+03 | -- | -- | -- | 1.41E+03 | -- |
| <i>Dehalobium chlorocoercia</i> | DECO | -- | -- | -- | -- | -- | -- | -- | 4.70E+00 U | -- | -- | -- | 2.29E+03 | -- |
| <i>Desulfuromonas</i> spp. | DSM | -- | -- | -- | -- | -- | -- | -- | 1.07E+03 | -- | -- | -- | 2.34E+03 | -- |
| Chloroform reductase | CFR | -- | -- | -- | -- | -- | -- | -- | 4.70E+00 U | -- | -- | -- | 4.80E+00 U | -- |
| 1,1-DCA Reductase | DCA | -- | -- | -- | -- | -- | -- | -- | 4.70E+00 U | -- | -- | -- | 4.80E+00 U | -- |
| 1,2-DCA Reductase | DCAR | -- | -- | -- | -- | -- | -- | -- | 4.70E+00 U | -- | -- | -- | 4.80E+00 U | -- |
| Aerobic Cometabolic | | | | | | | | | | | | | | |
| Soluble Methane Monooxygenase | SMMO | -- | -- | -- | -- | -- | -- | -- | 3.02E+04 | -- | -- | -- | 5.66E+02 | -- |
| Particulate Methane Monooxygenase | PMMO | -- | -- | -- | -- | -- | -- | -- | 1.78E+04 | -- | -- | -- | 1.84E+04 | -- |
| Toluene Dioxygenase | TOD | -- | -- | -- | -- | -- | -- | -- | 2.58E+02 | -- | -- | -- | 2.56E+02 | -- |
| Phenol Hydroxylase | PHE | -- | -- | -- | -- | -- | -- | -- | 3.85E+03 | -- | -- | -- | 1.69E+04 | -- |
| Trichlorobenzene Dioxygenase | TCBO | -- | -- | -- | -- | -- | -- | -- | 2.81E+01 | -- | -- | -- | 8.48E+01 | -- |
| Toluene Monooxygenase 2 | RDEG | -- | -- | -- | -- | -- | -- | -- | 1.18E+03 | -- | -- | -- | 1.93E+04 | -- |
| Toluene Monooxygenase | RMO | -- | -- | -- | -- | -- | -- | -- | 2.70E+00 J | -- | -- | -- | 4.80E+00 U | -- |
| Ethene Monooxygenase | EtnC | -- | -- | -- | -- | -- | -- | -- | 3.70E+01 | -- | -- | -- | 1.05E+01 | -- |
| Epoxyalkane transferase | EtnE | -- | -- | -- | -- | -- | -- | -- | 5.70E+00 | -- | -- | -- | 2.07E+01 | -- |
| Dichloromethane dehalogenase | DCMA | -- | -- | -- | -- | -- | -- | -- | 4.70E+00 U | -- | -- | -- | 4.80E+00 U | -- |
| Other | | | | | | | | | | | | | | |
| Total Eubacteria | EBAC | -- | -- | -- | -- | -- | -- | -- | 1.07E+06 | -- | -- | -- | 3.46E+06 | -- |
| Sulfate Reducing Bacteria | APS | -- | -- | -- | -- | -- | -- | -- | 4.68E+05 | -- | -- | -- | 2.08E+05 | -- |
| Methanogens | MGN | -- | -- | -- | -- | -- | -- | -- | 2.76E+03 | -- | -- | -- | 3.42E+03 | -- |
| CSIA | | $\delta^{13}\text{C}$ | $\delta^{13}\text{C}$ | $\delta^{13}\text{C}$ | $\delta^{13}\text{C}$ | $\delta^{13}\text{C}$ | $\delta^{13}\text{C}$ | $\delta^{13}\text{C}$ | $\delta^{13}\text{C}$ | $\delta^{13}\text{C}$ | $\delta^{13}\text{C}$ | $\delta^{13}\text{C}$ | $\delta^{13}\text{C}$ | $\delta^{13}\text{C}$ |
| Vinyl Chloride | | -- | -- | -- | -- | -- | -- | -- | -21.86 | -24.57 | -- | -- | -22.84 | -- |
| cis-1,2-dichloroethene | | -- | -- | -- | -- | -- | -- | -- | -8.31 | -9.46 | -- | -- | -17.70 | -- |
| Trichloroethene | | -- | -- | -- | -- | -- | -- | -- | -7.43 | U* | -- | -- | -21.72 J* | -- |

Notes:

BOLD value indicates the compound was detected above the reporting limit.

U indicates the compound was not detected at the indicated concentration.

J indicates the presence of a compound that meets the identification criteria. The result is less than the quantitation limit but greater than zero, and is given an approximate value.

-- indicates analysis was not performed

J*(CSIA): Target analyte produced a low weak signal; the result is considered usable to +/- 2 o/oo but not the standard +/- 0.5 o/oo

U* (CSIA): Either there was no peak corresponding to the target analyte or that such a peak did not produce a reliable CSIA result.

APPENDIX D.2: GROUNDWATER ANALYTICAL DATA SUMMARY (MICROBIAL COMMUNITY AND CSIA)

| Sample ID | | SMLS7-3 | SMLS7-3 | SMLS7-3 | SMLS7-4 | SMLS7-4 | SMLS7-4 | SMLS7-5 | SMLS7-5 | SMLS7-5 | SMLS7-6 | SMLS7-7 | SMLS8-1 | SMLS8-1 |
|-----------------------------------|------|-----------------------|-----------------------|-----------------------|-----------------------|-----------------------|-----------------------|-----------------------|-----------------------|-----------------------|-----------------------|-----------------------|-----------------------|-----------------------|
| Sampling Date | | 3/17/2015 | 12/8/2015 | 8/3/2016 | 3/23/2015 | 12/8/2015 | 8/3/2016 | 3/23/2015 | 12/8/2015 | 8/3/2016 | 3/17/2015 | 3/23/2015 | 3/23/2015 | 12/8/2015 |
| MICROBIAL COMMUNITY | | cells/mL | cells/mL | cells/mL | cells/mL | cells/mL | cells/mL | cells/mL | cells/mL | cells/mL | cells/mL | cells/mL | cells/mL | cells/mL |
| Reductive Dechlorination | | | | | | | | | | | | | | |
| <i>Dehalococcoides</i> spp. | DHC | 5.26E+04 | -- | 1.20E+04 | -- | 8.78E+04 | -- | -- | -- | -- | 4.62E+05 | -- | -- | -- |
| tceA Reductase | TCE | 2.69E+03 | -- | -- | -- | 4.55E+03 | -- | -- | -- | -- | 1.57E+03 | -- | -- | -- |
| BAV1 Vinyl Chloride Reductase | BVC | 1.07E+03 | -- | -- | -- | 5.39E+03 | -- | -- | -- | -- | 3.67E+03 | -- | -- | -- |
| Vinyl Chloride Reductase | VCR | 6.38E+03 | -- | -- | -- | 5.37E+04 | -- | -- | -- | -- | 5.29E+04 | -- | -- | -- |
| <i>Dehalobacter</i> spp. | DHBt | 4.45E+03 | -- | -- | -- | 1.93E+03 | -- | -- | -- | -- | 1.54E+03 | -- | -- | -- |
| <i>Dehalobacter</i> DCM | DCM | 6.40E+00 | -- | -- | -- | 4.70E+00 U | -- | -- | -- | -- | 4.80E+00 U | -- | -- | -- |
| <i>Dehalogenimonas</i> spp. | DHG | 1.04E+05 | -- | -- | -- | 1.60E+05 | -- | -- | -- | -- | 9.75E+04 | -- | -- | -- |
| <i>Desulfitobacterium</i> spp. | DSB | 2.91E+03 | -- | -- | -- | 2.82E+03 | -- | -- | -- | -- | 1.82E+03 | -- | -- | -- |
| <i>Dehalobium chlorocoercia</i> | DECO | 4.70E+00 U | -- | -- | -- | 4.12E+03 | -- | -- | -- | -- | 4.80E+00 U | -- | -- | -- |
| <i>Desulfuromonas</i> spp. | DSM | 5.46E+03 | -- | -- | -- | 4.70E+00 U | -- | -- | -- | -- | 9.74E+02 | -- | -- | -- |
| Chloroform reductase | CFR | 4.70E+00 U | -- | -- | -- | 4.70E+00 U | -- | -- | -- | -- | 6.12E+01 | -- | -- | -- |
| 1,1-DCA Reductase | DCA | 4.70E+00 U | -- | -- | -- | 4.70E+00 U | -- | -- | -- | -- | 4.80E+00 U | -- | -- | -- |
| 1,2-DCA Reductase | DCAR | 4.70E+00 U | -- | -- | -- | 4.70E+00 U | -- | -- | -- | -- | 4.80E+00 U | -- | -- | -- |
| Aerobic Cometabolic | | | | | | | | | | | | | | |
| Soluble Methane Monooxygenase | SMMO | 1.02E+04 | -- | -- | -- | 1.70E+03 | -- | -- | -- | -- | 2.45E+03 | -- | -- | -- |
| Particulate Methane Monooxygenase | PMMO | 8.71E+03 | -- | -- | -- | 4.82E+03 | -- | -- | -- | -- | 5.73E+03 | -- | -- | -- |
| Toluene Dioxygenase | TOD | 1.16E+02 | -- | -- | -- | 1.36E+02 | -- | -- | -- | -- | 2.17E+03 | -- | -- | -- |
| Phenol Hydroxylase | PHE | 3.60E+02 | -- | -- | -- | 2.35E+02 | -- | -- | -- | -- | 1.83E+02 | -- | -- | -- |
| Trichlorobenzene Dioxygenase | TCBO | 9.47E+01 | -- | -- | -- | 1.39E+01 | -- | -- | -- | -- | 4.80E+00 U | -- | -- | -- |
| Toluene Monooxygenase 2 | RDEG | 3.32E+02 | -- | -- | -- | 3.90E+00 J | -- | -- | -- | -- | 6.13E+01 | -- | -- | -- |
| Toluene Monooxygenase | RMO | 4.60E+00 J | -- | -- | -- | 4.70E+00 U | -- | -- | -- | -- | 1.50E+00 J | -- | -- | -- |
| Ethene Monooxygenase | EtnC | 3.03E+02 | -- | -- | -- | 7.70E+00 | -- | -- | -- | -- | 2.94E+01 | -- | -- | -- |
| Epoxyalkane transferase | EtnE | 6.90E+00 | -- | -- | -- | 5.10E+00 | -- | -- | -- | -- | 4.80E+00 U | -- | -- | -- |
| Dichloromethane dehalogenase | DCMA | 4.70E+00 U | -- | -- | -- | 4.70E+00 U | -- | -- | -- | -- | 4.80E+00 U | -- | -- | -- |
| Other | | | | | | | | | | | | | | |
| Total Eubacteria | EBAC | 2.03E+06 | -- | -- | -- | 2.64E+06 | -- | -- | -- | -- | 1.45E+06 | -- | -- | -- |
| Sulfate Reducing Bacteria | APS | 4.39E+05 | -- | -- | -- | 5.92E+04 | -- | -- | -- | -- | 2.77E+05 | -- | -- | -- |
| Methanogens | MGN | 1.80E+03 | -- | -- | -- | 4.58E+03 | -- | -- | -- | -- | 5.81E+03 | -- | -- | -- |
| CSIA | | | | | | | | | | | | | | |
| | | $\delta^{13}\text{C}$ | $\delta^{13}\text{C}$ | $\delta^{13}\text{C}$ | $\delta^{13}\text{C}$ | $\delta^{13}\text{C}$ | $\delta^{13}\text{C}$ | $\delta^{13}\text{C}$ | $\delta^{13}\text{C}$ | $\delta^{13}\text{C}$ | $\delta^{13}\text{C}$ | $\delta^{13}\text{C}$ | $\delta^{13}\text{C}$ | $\delta^{13}\text{C}$ |
| Vinyl Chloride | | -20.72 | -22.30 | -- | -- | -20.30 | -- | -- | -- | -- | -19.41 J* | -- | -- | -- |
| cis-1,2-dichloroethene | | -15.09 | -15.98 | -- | -- | -7.24 | -- | -- | -- | -- | -14.11 J* | -- | -- | -- |
| Trichloroethene | | -16.63 | U* | -- | -- | U* | -- | -- | -- | -- | -15.56 J* | -- | -- | -- |

Notes:

BOLD value indicates the compound was detected above the reporting limit.

U indicates the compound was not detected at the indicated concentration.

J indicates the presence of a compound that meets the identification criteria. The result is less than the quantitation limit but greater than zero, and is given an approximate value.

-- indicates analysis was not performed

J*(CSIA): Target analyte produced a low weak signal; the result is considered usable to +/- 2 o/oo but not the standard +/- 0.5 o/oo

U* (CSIA): Either there was no peak corresponding to the target analyte or that such a peak did not produce a reliable CSIA result.

APPENDIX D.2: GROUNDWATER ANALYTICAL DATA SUMMARY (MICROBIAL COMMUNITY AND CSIA)

| Sample ID | | SMLS8-2 | SMLS8-2 | SMLS8-3 | SMLS8-3 | SMLS8-4 | SMLS8-4 | SMLS8-5 | SMLS8-6 | SMLS8-7 | SPW-1 | SPW3-1 | SPW3-2 | PEW01 |
|-----------------------------------|------|----------------|----------------|----------------|----------------|----------------|----------------|----------------|----------------|----------------|-----------------|-----------------|-----------------|----------------|
| Sampling Date | | 3/23/2015 | 12/8/2015 | 3/23/2015 | 12/8/2015 | 3/23/2015 | 12/8/2015 | 3/23/2015 | 3/23/2015 | 3/23/2015 | 8/11/2016 | 8/11/2016 | 8/11/2016 | 3/16/2015 |
| MICROBIAL COMMUNITY | | cells/mL | cells/mL | cells/mL | cells/mL | cells/mL | cells/mL | cells/mL | cells/mL | cells/mL | cells/mL | cells/mL | cells/mL | cells/mL |
| Reductive Dechlorination | | | | | | | | | | | | | | |
| <i>Dehalococcoides</i> spp. | DHC | -- | -- | -- | -- | -- | -- | -- | -- | -- | 8.86E+04 | 1.78E+05 | 1.32E+05 | -- |
| tceA Reductase | TCE | -- | -- | -- | -- | -- | -- | -- | -- | -- | 4.72E+03 | 1.20E+04 | 6.85E+03 | -- |
| BAV1 Vinyl Chloride Reductase | BVC | -- | -- | -- | -- | -- | -- | -- | -- | -- | 4.15E+03 | 1.81E+04 | 1.15E+04 | -- |
| Vinyl Chloride Reductase | VCR | -- | -- | -- | -- | -- | -- | -- | -- | -- | 3.62E+04 | 7.27E+03 | 2.37E+04 | -- |
| <i>Dehalobacter</i> spp. | DHBt | -- | -- | -- | -- | -- | -- | -- | -- | -- | 1.11E+03 | 5.88E+02 | 1.01E+03 | -- |
| <i>Dehalobacter</i> DCM | DCM | -- | -- | -- | -- | -- | -- | -- | -- | -- | 6.30E+00 U | 6.30E+00 U | 6.80E+00 U | -- |
| <i>Dehalogenimonas</i> spp. | DHG | -- | -- | -- | -- | -- | -- | -- | -- | -- | 2.05E+05 | 1.74E+05 | 3.66E+05 | -- |
| <i>Desulfitobacterium</i> spp. | DSB | -- | -- | -- | -- | -- | -- | -- | -- | -- | 7.63E+03 | 4.26E+03 | 1.78E+03 | -- |
| <i>Dehalobium chlorocoercia</i> | DECO | -- | -- | -- | -- | -- | -- | -- | -- | -- | 1.78E+03 | 1.05E+03 | 1.89E+03 | -- |
| <i>Desulfuromonas</i> spp. | DSM | -- | -- | -- | -- | -- | -- | -- | -- | -- | 4.03E+04 | 3.70E+04 | 3.18E+04 | -- |
| Chloroform reductase | CFR | -- | -- | -- | -- | -- | -- | -- | -- | -- | 6.30E+00 U | 6.30E+00 U | 6.80E+00 U | -- |
| 1,1-DCA Reductase | DCA | -- | -- | -- | -- | -- | -- | -- | -- | -- | 6.30E+00 U | 6.30E+00 U | 6.80E+00 U | -- |
| 1,2-DCA Reductase | DCAR | -- | -- | -- | -- | -- | -- | -- | -- | -- | 6.30E+00 U | 6.30E+00 U | 6.80E+00 U | -- |
| Aerobic Cometabolic | | | | | | | | | | | | | | |
| Soluble Methane Monooxygenase | SMMO | -- | -- | -- | -- | -- | -- | -- | -- | -- | 2.99E+02 | 3.01E+02 | 7.45E+02 | -- |
| Particulate Methane Monooxygenase | PMMO | -- | -- | -- | -- | -- | -- | -- | -- | -- | 2.70E+03 | 6.17E+03 | 3.32E+03 | -- |
| Toluene Dioxygenase | TOD | -- | -- | -- | -- | -- | -- | -- | -- | -- | 1.19E+03 | 5.99E+01 | 1.64E+02 | -- |
| Phenol Hydroxylase | PHE | -- | -- | -- | -- | -- | -- | -- | -- | -- | 8.14E+02 | 1.50E+03 | 4.14E+02 | -- |
| Trichlorobenzene Dioxygenase | TCBO | -- | -- | -- | -- | -- | -- | -- | -- | -- | 9.46E+01 | 1.02E+02 | 6.80E+00 U | -- |
| Toluene Monooxygenase 2 | RDEG | -- | -- | -- | -- | -- | -- | -- | -- | -- | 4.44E+02 | 1.69E+03 | 2.76E+02 | -- |
| Toluene Monooxygenase | RMO | -- | -- | -- | -- | -- | -- | -- | -- | -- | 6.30E+00 U | 6.30E+00 U | 6.80E+00 U | -- |
| Ethene Monooxygenase | EtnC | -- | -- | -- | -- | -- | -- | -- | -- | -- | 4.17E+01 | 1.84E+03 | 2.17E+02 | -- |
| Epoxyalkane transferase | EtnE | -- | -- | -- | -- | -- | -- | -- | -- | -- | 2.37E+01 | 1.10E+03 | 6.42E+02 | -- |
| Dichloromethane dehalogenase | DCMA | -- | -- | -- | -- | -- | -- | -- | -- | -- | 6.30E+00 U | 6.30E+00 U | 6.80E+00 U | -- |
| Other | | | | | | | | | | | | | | |
| Total Eubacteria | EBAC | -- | -- | -- | -- | -- | -- | -- | -- | -- | 2.83E+06 | 2.83E+06 | 2.88E+06 | -- |
| Sulfate Reducing Bacteria | APS | -- | -- | -- | -- | -- | -- | -- | -- | -- | 1.17E+06 | 2.61E+05 | 1.76E+06 | -- |
| Methanogens | MGN | -- | -- | -- | -- | -- | -- | -- | -- | -- | 6.15E+01 | 4.84E+01 | 2.91E+02 | -- |
| CSIA | | | | | | | | | | | | | | |
| | | $\delta^{13}C$ | $\delta^{13}C$ | $\delta^{13}C$ | $\delta^{13}C$ | $\delta^{13}C$ | $\delta^{13}C$ | $\delta^{13}C$ | $\delta^{13}C$ | $\delta^{13}C$ | $\delta^{13}C$ | $\delta^{13}C$ | $\delta^{13}C$ | $\delta^{13}C$ |
| Vinyl Chloride | | -- | -- | -- | -- | -- | -- | -- | -- | -- | -36.52 | -33.46 | -34.13 | -- |
| cis-1,2-dichloroethene | | -- | -- | -- | -- | -- | -- | -- | -- | -- | -21.70 | -22.48 | -17.38 | -- |
| Trichloroethene | | -- | -- | -- | -- | -- | -- | -- | -- | -- | -21.55 | -22.19 | -16.47 | -- |

Notes:

BOLD value indicates the compound was detected above the reporting limit.

U indicates the compound was not detected at the indicated concentration.

J indicates the presence of a compound that meets the identification criteria. The result is less than the quantitation limit but greater than zero, and is given an approximate value.

-- indicates analysis was not performed

J*(CSIA): Target analyte produced a low weak signal; the result is considered usable to +/- 2 o/oo but not the standard +/- 0.5 o/oo

U* (CSIA): Either there was no peak corresponding to the target analyte or that such a peak did not produce a reliable CSIA result.

APPENDIX D.2: GROUNDWATER ANALYTICAL DATA SUMMARY (MICROBIAL COMMUNITY AND CSIA)

| Sample ID | | PEW01 | PEW01 | PEW02 | PEW02 | PEW02 | PEW03 | PEW03 | PEW03 | PEW04 | PEW04 | PEW04 | PMLS1-1 | PMLS1-1 |
|-----------------------------------|------|-----------------------|-----------------------|-----------------------|-----------------------|-----------------------|-----------------------|-----------------------|-----------------------|-----------------------|-----------------------|-----------------------|-----------------------|-----------------------|
| Sampling Date | | 12/9/2015 | 8/2/2016 | 3/16/2015 | 12/9/2015 | 8/11/2016 | 3/16/2015 | 12/9/2015 | 8/1/2016 | 3/16/2015 | 12/9/2015 | 8/1/2016 | 3/9/2015 | 12/1/2015 |
| MICROBIAL COMMUNITY | | cells/mL | cells/mL | cells/mL | cells/mL | cells/mL | cells/mL | cells/mL | cells/mL | cells/mL | cells/mL | cells/mL | cells/mL | cells/mL |
| Reductive Dechlorination | | | | | | | | | | | | | | |
| <i>Dehalococcoides</i> spp. | DHC | -- | -- | 1.83E+04 | -- | 1.93E+04 | 9.65E+01 | -- | 4.08E+02 | -- | -- | -- | -- | -- |
| tceA Reductase | TCE | -- | -- | 3.95E+03 | -- | 7.94E+03 | 4.60E+00 | -- | -- | -- | -- | -- | -- | -- |
| BAV1 Vinyl Chloride Reductase | BVC | -- | -- | 1.15E+02 | -- | 4.97E+02 | 4.00E-01 J | -- | -- | -- | -- | -- | -- | -- |
| Vinyl Chloride Reductase | VCR | -- | -- | 7.04E+03 | -- | 1.14E+04 | 1.10E+00 | -- | -- | -- | -- | -- | -- | -- |
| <i>Dehalobacter</i> spp. | DHBt | -- | -- | 6.53E+03 | -- | 1.20E+00 J | 2.73E+03 | -- | -- | -- | -- | -- | -- | -- |
| <i>Dehalobacter</i> DCM | DCM | -- | -- | 4.70E+00 U | -- | 4.80E+00 U | 4.70E+00 U | -- | -- | -- | -- | -- | -- | -- |
| <i>Dehalogenimonas</i> spp. | DHG | -- | -- | 1.26E+05 | -- | 2.02E+05 | 4.30E+04 | -- | -- | -- | -- | -- | -- | -- |
| <i>Desulfitobacterium</i> spp. | DSB | -- | -- | 3.20E+03 | -- | 1.51E+02 | 1.11E+03 | -- | -- | -- | -- | -- | -- | -- |
| <i>Dehalobium chlorocoercia</i> | DECO | -- | -- | 4.70E+00 U | -- | 1.85E+03 | 4.70E+00 U | -- | -- | -- | -- | -- | -- | -- |
| <i>Desulfuromonas</i> spp. | DSM | -- | -- | 2.78E+03 | -- | 4.80E+00 U | 1.09E+03 | -- | -- | -- | -- | -- | -- | -- |
| Chloroform reductase | CFR | -- | -- | 4.70E+00 U | -- | 4.80E+00 U | 4.70E+00 U | -- | -- | -- | -- | -- | -- | -- |
| 1,1-DCA Reductase | DCA | -- | -- | 4.70E+00 U | -- | 4.80E+00 U | 4.70E+00 U | -- | -- | -- | -- | -- | -- | -- |
| 1,2-DCA Reductase | DCAR | -- | -- | 4.70E+00 U | -- | 4.80E+00 U | 4.70E+00 U | -- | -- | -- | -- | -- | -- | -- |
| Aerobic Cometabolic | | | | | | | | | | | | | | |
| Soluble Methane Monooxygenase | SMMO | -- | -- | 1.64E+04 | -- | 8.31E+02 | 2.27E+04 | -- | -- | -- | -- | -- | -- | -- |
| Particulate Methane Monooxygenase | PMMO | -- | -- | 8.23E+03 | -- | 1.34E+03 | 4.45E+04 | -- | -- | -- | -- | -- | -- | -- |
| Toluene Dioxygenase | TOD | -- | -- | 2.30E+02 | -- | 1.70E+00 J | 9.98E+02 | -- | -- | -- | -- | -- | -- | -- |
| Phenol Hydroxylase | PHE | -- | -- | 4.29E+03 | -- | 4.49E+02 | 2.70E+03 | -- | -- | -- | -- | -- | -- | -- |
| Trichlorobenzene Dioxygenase | TCBO | -- | -- | 9.40E+01 | -- | 4.80E+00 U | 2.54E+02 | -- | -- | -- | -- | -- | -- | -- |
| Toluene Monooxygenase 2 | RDEG | -- | -- | 1.35E+03 | -- | 1.28E+02 | 8.05E+02 | -- | -- | -- | -- | -- | -- | -- |
| Toluene Monooxygenase | RMO | -- | -- | 4.60E+00 J | -- | 4.80E+00 U | 2.62E+02 | -- | -- | -- | -- | -- | -- | -- |
| Ethene Monooxygenase | EtnC | -- | -- | 2.83E+01 | -- | 1.52E+01 | 4.70E+00 U | -- | -- | -- | -- | -- | -- | -- |
| Epoxyalkane transferase | EtnE | -- | -- | 6.30E+00 | -- | 1.90E+01 | 4.70E+00 U | -- | -- | -- | -- | -- | -- | -- |
| Dichloromethane dehalogenase | DCMA | -- | -- | 4.70E+00 U | -- | 4.80E+00 U | 4.70E+00 U | -- | -- | -- | -- | -- | -- | -- |
| Other | | | | | | | | | | | | | | |
| Total Eubacteria | EBAC | -- | -- | 2.19E+06 | -- | 7.55E+05 | 1.71E+06 | -- | -- | -- | -- | -- | -- | -- |
| Sulfate Reducing Bacteria | APS | -- | -- | 7.84E+05 | -- | 5.32E+05 | 7.26E+05 | -- | -- | -- | -- | -- | -- | -- |
| Methanogens | MGN | -- | -- | 1.31E+03 | -- | 4.80E+00 U | 2.89E+04 | -- | -- | -- | -- | -- | -- | -- |
| CSIA | | | | | | | | | | | | | | |
| | | $\delta^{13}\text{C}$ | $\delta^{13}\text{C}$ | $\delta^{13}\text{C}$ | $\delta^{13}\text{C}$ | $\delta^{13}\text{C}$ | $\delta^{13}\text{C}$ | $\delta^{13}\text{C}$ | $\delta^{13}\text{C}$ | $\delta^{13}\text{C}$ | $\delta^{13}\text{C}$ | $\delta^{13}\text{C}$ | $\delta^{13}\text{C}$ | $\delta^{13}\text{C}$ |
| Vinyl Chloride | | -- | -- | -24.60 | -23.55 | -33.53 | -14.86 J* | 8.55 | 15.90 | -- | -- | -- | -- | -- |
| cis-1,2-dichloroethene | | -- | -- | 2.97 | -4.14 | -8.62 | -9.79 J* | 38.62 | 29.50 | -- | -- | -- | -- | -- |
| Trichloroethene | | -- | -- | -13.19 J* | -23.84 J* | 18.26 | -17.96 J* | U* | U* | -- | -- | -- | -- | -- |

Notes:

BOLD value indicates the compound was detected above the reporting limit.

U indicates the compound was not detected at the indicated concentration.

J indicates the presence of a compound that meets the identification criteria. The result is less than the quantitation limit but greater than zero, and is given an approximate value.

-- indicates analysis was not performed

J*(CSIA): Target analyte produced a low weak signal; the result is considered usable to +/- 2 o/oo but not the standard +/- 0.5 o/oo

U* (CSIA): Either there was no peak corresponding to the target analyte or that such a peak did not produce a reliable CSIA result.

APPENDIX D.2: GROUNDWATER ANALYTICAL DATA SUMMARY (MICROBIAL COMMUNITY AND CSIA)

| Sample ID | | PMLS1-2 | PMLS1-2 | PMLS1-3 | PMLS1-3 | PMLS1-4 | PMLS1-4 | PMLS1-5 | PMLS1-6 | PMLS1-7 | PMLS2-1 | PMLS2-1 | PMLS2-1 | PMLS2-2 | PMLS2-2 |
|-----------------------------------|------|-----------------------|-----------------------|-----------------------|-----------------------|-----------------------|-----------------------|-----------------------|-----------------------|-----------------------|-----------------------|-----------------------|-----------------------|-----------------------|-----------------------|
| Sampling Date | | 3/9/2015 | 12/1/2015 | 3/9/2015 | 12/1/2015 | 3/9/2015 | 12/1/2015 | 3/9/2015 | 3/9/2015 | 3/9/2015 | 3/9/2015 | 12/1/2015 | 8/1/2016 | 3/9/2015 | 12/1/2015 |
| MICROBIAL COMMUNITY | | cells/mL | cells/mL | cells/mL | cells/mL | cells/mL | cells/mL | cells/mL | cells/mL | cells/mL | cells/mL | cells/mL | cells/mL | cells/mL | cells/mL |
| Reductive Dechlorination | | | | | | | | | | | | | | | |
| <i>Dehalococcoides</i> spp. | DHC | -- | -- | -- | -- | -- | -- | -- | -- | -- | -- | -- | 6.43E+03 | -- | -- |
| tceA Reductase | TCE | -- | -- | -- | -- | -- | -- | -- | -- | -- | -- | -- | -- | -- | -- |
| BAV1 Vinyl Chloride Reductase | BVC | -- | -- | -- | -- | -- | -- | -- | -- | -- | -- | -- | -- | -- | -- |
| Vinyl Chloride Reductase | VCR | -- | -- | -- | -- | -- | -- | -- | -- | -- | -- | -- | -- | -- | -- |
| <i>Dehalobacter</i> spp. | DHBt | -- | -- | -- | -- | -- | -- | -- | -- | -- | -- | -- | -- | -- | -- |
| <i>Dehalobacter</i> DCM | DCM | -- | -- | -- | -- | -- | -- | -- | -- | -- | -- | -- | -- | -- | -- |
| <i>Dehalogenimonas</i> spp. | DHG | -- | -- | -- | -- | -- | -- | -- | -- | -- | -- | -- | -- | -- | -- |
| <i>Desulfitobacterium</i> spp. | DSB | -- | -- | -- | -- | -- | -- | -- | -- | -- | -- | -- | -- | -- | -- |
| <i>Dehalobium chlorocoercia</i> | DECO | -- | -- | -- | -- | -- | -- | -- | -- | -- | -- | -- | -- | -- | -- |
| <i>Desulfuromonas</i> spp. | DSM | -- | -- | -- | -- | -- | -- | -- | -- | -- | -- | -- | -- | -- | -- |
| Chloroform reductase | CFR | -- | -- | -- | -- | -- | -- | -- | -- | -- | -- | -- | -- | -- | -- |
| 1,1-DCA Reductase | DCA | -- | -- | -- | -- | -- | -- | -- | -- | -- | -- | -- | -- | -- | -- |
| 1,2-DCA Reductase | DCAR | -- | -- | -- | -- | -- | -- | -- | -- | -- | -- | -- | -- | -- | -- |
| Aerobic Cometabolic | | | | | | | | | | | | | | | |
| Soluble Methane Monooxygenase | SMMO | -- | -- | -- | -- | -- | -- | -- | -- | -- | -- | -- | -- | -- | -- |
| Particulate Methane Monooxygenase | PMMO | -- | -- | -- | -- | -- | -- | -- | -- | -- | -- | -- | -- | -- | -- |
| Toluene Dioxygenase | TOD | -- | -- | -- | -- | -- | -- | -- | -- | -- | -- | -- | -- | -- | -- |
| Phenol Hydroxylase | PHE | -- | -- | -- | -- | -- | -- | -- | -- | -- | -- | -- | -- | -- | -- |
| Trichlorobenzene Dioxygenase | TCBO | -- | -- | -- | -- | -- | -- | -- | -- | -- | -- | -- | -- | -- | -- |
| Toluene Monooxygenase 2 | RDEG | -- | -- | -- | -- | -- | -- | -- | -- | -- | -- | -- | -- | -- | -- |
| Toluene Monooxygenase | RMO | -- | -- | -- | -- | -- | -- | -- | -- | -- | -- | -- | -- | -- | -- |
| Ethene Monooxygenase | EtnC | -- | -- | -- | -- | -- | -- | -- | -- | -- | -- | -- | -- | -- | -- |
| Epoxyalkane transferase | EtnE | -- | -- | -- | -- | -- | -- | -- | -- | -- | -- | -- | -- | -- | -- |
| Dichloromethane dehalogenase | DCMA | -- | -- | -- | -- | -- | -- | -- | -- | -- | -- | -- | -- | -- | -- |
| Other | | | | | | | | | | | | | | | |
| Total Eubacteria | EBAC | -- | -- | -- | -- | -- | -- | -- | -- | -- | -- | -- | -- | -- | -- |
| Sulfate Reducing Bacteria | APS | -- | -- | -- | -- | -- | -- | -- | -- | -- | -- | -- | -- | -- | -- |
| Methanogens | MGN | -- | -- | -- | -- | -- | -- | -- | -- | -- | -- | -- | -- | -- | -- |
| CSIA | | $\delta^{13}\text{C}$ | $\delta^{13}\text{C}$ | $\delta^{13}\text{C}$ | $\delta^{13}\text{C}$ | $\delta^{13}\text{C}$ | $\delta^{13}\text{C}$ | $\delta^{13}\text{C}$ | $\delta^{13}\text{C}$ | $\delta^{13}\text{C}$ | $\delta^{13}\text{C}$ | $\delta^{13}\text{C}$ | $\delta^{13}\text{C}$ | $\delta^{13}\text{C}$ | $\delta^{13}\text{C}$ |
| Vinyl Chloride | | -- | -- | -- | -- | -- | -- | -- | -- | -- | -- | -- | -33.47 | -- | -- |
| cis-1,2-dichloroethene | | -- | -- | -- | -- | -- | -- | -- | -- | -- | -- | -- | -26.71 | -- | -- |
| Trichloroethene | | -- | -- | -- | -- | -- | -- | -- | -- | -- | -- | -- | -19.14 | -- | -- |

Notes:

BOLD value indicates the compound was detected above the reporting limit.

U indicates the compound was not detected at the indicated concentration.

J indicates the presence of a compound that meets the identification criteria. The result is less than the quantitation limit but greater than zero, and is given an approximate value.

-- indicates analysis was not performed

J*(CSIA): Target analyte produced a low weak signal; the result is considered usable to +/- 2 o/oo but not the standard +/- 0.5 o/oo

U* (CSIA): Either there was no peak corresponding to the target analyte or that such a peak did not produce a reliable CSIA result.

APPENDIX D.2: GROUNDWATER ANALYTICAL DATA SUMMARY (MICROBIAL COMMUNITY AND CSIA)

| Sample ID | | PMLS2-2 | PMLS2-3 | PMLS2-3 | PMLS2-3 | PMLS2-4 | PMLS2-4 | PMLS2-5 | PMLS2-6 | PMLS2-7 | PMLS3-1 | PMLS3-1 | PMLS3-1 | PMLS3-2 | PMLS3-2 |
|-----------------------------------|------|-----------------------|-----------------------|-----------------------|-----------------------|-----------------------|-----------------------|-----------------------|-----------------------|-----------------------|-----------------------|-----------------------|-----------------------|-----------------------|-----------------------|
| Sampling Date | | 8/1/2016 | 3/9/2015 | 12/1/2015 | 8/1/2016 | 3/10/2015 | 12/1/2015 | 3/10/2015 | 3/10/2015 | 3/10/2015 | 3/10/2015 | 12/2/2015 | 8/1/2016 | 3/10/2015 | 12/2/2015 |
| MICROBIAL COMMUNITY | | cells/mL | cells/mL | cells/mL | cells/mL | cells/mL | cells/mL | cells/mL | cells/mL | cells/mL | cells/mL | cells/mL | cells/mL | cells/mL | cells/mL |
| Reductive Dechlorination | | | | | | | | | | | | | | | |
| <i>Dehalococcoides</i> spp. | DHC | 2.57E+04 | -- | -- | -- | -- | -- | -- | -- | -- | -- | 8.60E+04 | 1.80E+04 | -- | -- |
| tceA Reductase | TCE | -- | -- | -- | -- | -- | -- | -- | -- | -- | -- | 9.64E+03 | -- | -- | -- |
| BAV1 Vinyl Chloride Reductase | BVC | -- | -- | -- | -- | -- | -- | -- | -- | -- | -- | 8.10E+00 | -- | -- | -- |
| Vinyl Chloride Reductase | VCR | -- | -- | -- | -- | -- | -- | -- | -- | -- | -- | 1.56E+04 | -- | -- | -- |
| <i>Dehalobacter</i> spp. | DHBt | -- | -- | -- | -- | -- | -- | -- | -- | -- | -- | 4.97E+02 | -- | -- | -- |
| <i>Dehalobacter</i> DCM | DCM | -- | -- | -- | -- | -- | -- | -- | -- | -- | -- | 4.70E+00 U | -- | -- | -- |
| <i>Dehalogenimonas</i> spp. | DHG | -- | -- | -- | -- | -- | -- | -- | -- | -- | -- | 4.83E+05 | -- | -- | -- |
| <i>Desulfitobacterium</i> spp. | DSB | -- | -- | -- | -- | -- | -- | -- | -- | -- | -- | 2.32E+03 | -- | -- | -- |
| <i>Dehalobium chlorocoercia</i> | DECO | -- | -- | -- | -- | -- | -- | -- | -- | -- | -- | 2.94E+03 | -- | -- | -- |
| <i>Desulfuromonas</i> spp. | DSM | -- | -- | -- | -- | -- | -- | -- | -- | -- | -- | 6.51E+03 | -- | -- | -- |
| Chloroform reductase | CFR | -- | -- | -- | -- | -- | -- | -- | -- | -- | -- | 4.70E+00 U | -- | -- | -- |
| 1,1-DCA Reductase | DCA | -- | -- | -- | -- | -- | -- | -- | -- | -- | -- | 4.70E+00 U | -- | -- | -- |
| 1,2-DCA Reductase | DCAR | -- | -- | -- | -- | -- | -- | -- | -- | -- | -- | 4.70E+00 U | -- | -- | -- |
| Aerobic Cometabolic | | | | | | | | | | | | | | | |
| Soluble Methane Monooxygenase | SMMO | -- | -- | -- | -- | -- | -- | -- | -- | -- | -- | 1.34E+02 | -- | -- | -- |
| Particulate Methane Monooxygenase | PMMO | -- | -- | -- | -- | -- | -- | -- | -- | -- | -- | 7.55E+02 | -- | -- | -- |
| Toluene Dioxygenase | TOD | -- | -- | -- | -- | -- | -- | -- | -- | -- | -- | 4.90E+01 | -- | -- | -- |
| Phenol Hydroxylase | PHE | -- | -- | -- | -- | -- | -- | -- | -- | -- | -- | 3.65E+02 | -- | -- | -- |
| Trichlorobenzene Dioxygenase | TCBO | -- | -- | -- | -- | -- | -- | -- | -- | -- | -- | 1.75E+02 | -- | -- | -- |
| Toluene Monooxygenase 2 | RDEG | -- | -- | -- | -- | -- | -- | -- | -- | -- | -- | 9.53E+02 | -- | -- | -- |
| Toluene Monooxygenase | RMO | -- | -- | -- | -- | -- | -- | -- | -- | -- | -- | 4.70E+00 U | -- | -- | -- |
| Ethene Monooxygenase | EtnC | -- | -- | -- | -- | -- | -- | -- | -- | -- | -- | 8.97E+02 | -- | -- | -- |
| Epoxyalkane transferase | EtnE | -- | -- | -- | -- | -- | -- | -- | -- | -- | -- | 1.84E+04 | -- | -- | -- |
| Dichloromethane dehalogenase | DCMA | -- | -- | -- | -- | -- | -- | -- | -- | -- | -- | 4.70E+00 U | -- | -- | -- |
| Other | | | | | | | | | | | | | | | |
| Total Eubacteria | EBAC | -- | -- | -- | -- | -- | -- | -- | -- | -- | -- | 6.70E+05 | -- | -- | -- |
| Sulfate Reducing Bacteria | APS | -- | -- | -- | -- | -- | -- | -- | -- | -- | -- | 5.93E+05 | -- | -- | -- |
| Methanogens | MGN | -- | -- | -- | -- | -- | -- | -- | -- | -- | -- | 1.67E+02 | -- | -- | -- |
| CSIA | | $\delta^{13}\text{C}$ | $\delta^{13}\text{C}$ | $\delta^{13}\text{C}$ | $\delta^{13}\text{C}$ | $\delta^{13}\text{C}$ | $\delta^{13}\text{C}$ | $\delta^{13}\text{C}$ | $\delta^{13}\text{C}$ | $\delta^{13}\text{C}$ | $\delta^{13}\text{C}$ | $\delta^{13}\text{C}$ | $\delta^{13}\text{C}$ | $\delta^{13}\text{C}$ | $\delta^{13}\text{C}$ |
| Vinyl Chloride | | -23.27 | -- | -- | 3.74 | -- | -- | -- | -- | -- | -- | -32.31 | -33.46 | -- | -- |
| cis-1,2-dichloroethene | | -14.36 | -- | -- | -1.14 | -- | -- | -- | -- | -- | -- | -22.54 | -21.22 | -- | -- |
| Trichloroethene | | -18.17 | -- | -- | -19.05 | -- | -- | -- | -- | -- | -- | -17.12 | -18.32 | -- | -- |

Notes:

BOLD value indicates the compound was detected above the reporting limit.

U indicates the compound was not detected at the indicated concentration.

J indicates the presence of a compound that meets the identification criteria. The result is less than the quantitation limit but greater than zero, and is given an approximate value.

-- indicates analysis was not performed

J*(CSIA): Target analyte produced a low weak signal; the result is considered usable to +/- 2 o/oo but not the standard +/- 0.5 o/oo

U* (CSIA): Either there was no peak corresponding to the target analyte or that such a peak did not produce a reliable CSIA result.

APPENDIX D.2: GROUNDWATER ANALYTICAL DATA SUMMARY (MICROBIAL COMMUNITY AND CSIA)

| Sample ID | | PMLS3-2 | PMLS3-3 | PMLS3-3 | PMLS3-3 | PMLS3-4 | PMLS3-4 | PMLS3-5 | PMLS3-5 | PMLS3-6 | PMLS3-7 | PMLS4-1 | PMLS4-1 | PMLS4-1 |
|-----------------------------------|------|-----------------------|-----------------------|-----------------------|-----------------------|-----------------------|-----------------------|-----------------------|-----------------------|-----------------------|-----------------------|-----------------------|-----------------------|-----------------------|
| Sampling Date | | 8/1/2016 | 3/10/2015 | 12/2/2015 | 8/1/2016 | 3/10/2015 | 12/2/2015 | 3/10/2015 | 12/2/2015 | 3/10/2015 | 3/10/2015 | 3/11/2015 | 12/2/2015 | 8/1/2016 |
| MICROBIAL COMMUNITY | | cells/mL | cells/mL | cells/mL | cells/mL | cells/mL | cells/mL | cells/mL | cells/mL | cells/mL | cells/mL | cells/mL | cells/mL | cells/mL |
| Reductive Dechlorination | | | | | | | | | | | | | | |
| <i>Dehalococcoides</i> spp. | DHC | 1.04E+04 | -- | 2.72E+02 | -- | -- | -- | -- | -- | -- | -- | 2.18E+04 | 1.12E+04 | 9.51E+04 |
| tceA Reductase | TCE | -- | -- | 1.38E+02 | -- | -- | -- | -- | -- | -- | -- | 8.05E+03 | 1.06E+04 | -- |
| BAV1 Vinyl Chloride Reductase | BVC | -- | -- | 5.00E-01 U | -- | -- | -- | -- | -- | -- | -- | 1.63E+01 | 5.00E-01 U | -- |
| Vinyl Chloride Reductase | VCR | -- | -- | 7.35E+01 | -- | -- | -- | -- | -- | -- | -- | 8.45E+03 | 2.22E+04 | -- |
| <i>Dehalobacter</i> spp. | DHBt | -- | -- | 4.80E+00 U | -- | -- | -- | -- | -- | -- | -- | 3.50E+03 | 4.44E+02 | -- |
| <i>Dehalobacter</i> DCM | DCM | -- | -- | 4.80E+00 U | -- | -- | -- | -- | -- | -- | -- | 4.70E+00 U | 4.60E+00 U | -- |
| <i>Dehalogenimonas</i> spp. | DHG | -- | -- | 2.85E+03 | -- | -- | -- | -- | -- | -- | -- | 3.41E+05 | 5.37E+05 | -- |
| <i>Desulfitobacterium</i> spp. | DSB | -- | -- | 4.80E+00 U | -- | -- | -- | -- | -- | -- | -- | 3.76E+03 | 3.06E+03 | -- |
| <i>Dehalobium chlorocoercia</i> | DECO | -- | -- | 6.45E+01 | -- | -- | -- | -- | -- | -- | -- | 4.70E+00 U | 5.30E+03 | -- |
| <i>Desulfuromonas</i> spp. | DSM | -- | -- | 4.80E+00 U | -- | -- | -- | -- | -- | -- | -- | 2.08E+03 | 3.18E+03 | -- |
| Chloroform reductase | CFR | -- | -- | 4.80E+00 U | -- | -- | -- | -- | -- | -- | -- | 4.70E+00 U | 4.60E+00 U | -- |
| 1,1-DCA Reductase | DCA | -- | -- | 4.80E+00 U | -- | -- | -- | -- | -- | -- | -- | 4.70E+00 U | 4.60E+00 U | -- |
| 1,2-DCA Reductase | DCAR | -- | -- | 4.80E+00 U | -- | -- | -- | -- | -- | -- | -- | 4.70E+00 U | 4.60E+00 U | -- |
| Aerobic Cometabolic | | | | | | | | | | | | | | |
| Soluble Methane Monooxygenase | SMMO | -- | -- | 1.52E+02 | -- | -- | -- | -- | -- | -- | -- | 1.44E+03 | 1.96E+02 | -- |
| Particulate Methane Monooxygenase | PMMO | -- | -- | 4.10E+00 J | -- | -- | -- | -- | -- | -- | -- | 4.90E+02 | 4.70E+02 | -- |
| Toluene Dioxygenase | TOD | -- | -- | 3.70E+00 J | -- | -- | -- | -- | -- | -- | -- | 1.78E+03 | 2.37E+01 | -- |
| Phenol Hydroxylase | PHE | -- | -- | 4.80E+00 U | -- | -- | -- | -- | -- | -- | -- | 5.28E+01 | 4.30E+00 J | -- |
| Trichlorobenzene Dioxygenase | TCBO | -- | -- | 4.80E+00 U | -- | -- | -- | -- | -- | -- | -- | 4.70E+00 U | 4.60E+00 U | -- |
| Toluene Monooxygenase 2 | RDEG | -- | -- | 4.80E+00 U | -- | -- | -- | -- | -- | -- | -- | 4.70E+00 U | 8.63E+01 | -- |
| Toluene Monooxygenase | RMO | -- | -- | 4.80E+00 U | -- | -- | -- | -- | -- | -- | -- | 5.00E-01 J | 4.60E+00 U | -- |
| Ethene Monooxygenase | EtnC | -- | -- | 4.80E+00 U | -- | -- | -- | -- | -- | -- | -- | 1.39E+02 | 5.46E+02 | -- |
| Epoxyalkane transferase | EtnE | -- | -- | 4.80E+00 U | -- | -- | -- | -- | -- | -- | -- | 2.08E+03 | 2.27E+03 | -- |
| Dichloromethane dehalogenase | DCMA | -- | -- | 4.80E+00 U | -- | -- | -- | -- | -- | -- | -- | 4.70E+00 U | 4.60E+00 U | -- |
| Other | | | | | | | | | | | | | | |
| Total Eubacteria | EBAC | -- | -- | 6.96E+03 | -- | -- | -- | -- | -- | -- | -- | 2.35E+06 | 1.11E+06 | -- |
| Sulfate Reducing Bacteria | APS | -- | -- | 3.69E+03 | -- | -- | -- | -- | -- | -- | -- | 4.47E+05 | 4.48E+05 | -- |
| Methanogens | MGN | -- | -- | 2.24E+02 | -- | -- | -- | -- | -- | -- | -- | 1.08E+04 | 9.80E+02 | -- |
| CSIA | | | | | | | | | | | | | | |
| | | $\delta^{13}\text{C}$ | $\delta^{13}\text{C}$ | $\delta^{13}\text{C}$ | $\delta^{13}\text{C}$ | $\delta^{13}\text{C}$ | $\delta^{13}\text{C}$ | $\delta^{13}\text{C}$ | $\delta^{13}\text{C}$ | $\delta^{13}\text{C}$ | $\delta^{13}\text{C}$ | $\delta^{13}\text{C}$ | $\delta^{13}\text{C}$ | $\delta^{13}\text{C}$ |
| Vinyl Chloride | | -19.78 | -- | -12.30 | 11.24 | -- | -- | -- | -- | -- | -- | -33.83 | -32.24 | -30.22 |
| cis-1,2-dichloroethene | | -6.15 | -- | 9.90 | 19.44 | -- | -- | -- | -- | -- | -- | -24.97 | -20.49 | -19.38 |
| Trichloroethene | | -17.47 | -- | -20.44 | U* | -- | -- | -- | -- | -- | -- | -18.34 | -15.08 | -22.39 |

Notes:

BOLD value indicates the compound was detected above the reporting limit.

U indicates the compound was not detected at the indicated concentration.

J indicates the presence of a compound that meets the identification criteria. The result is less than the quantitation limit but greater than zero, and is given an approximate value.

-- indicates analysis was not performed

J*(CSIA): Target analyte produced a low weak signal; the result is considered usable to +/- 2 o/oo but not the standard +/- 0.5 o/oo

U* (CSIA): Either there was no peak corresponding to the target analyte or that such a peak did not produce a reliable CSIA result.

APPENDIX D.2: GROUNDWATER ANALYTICAL DATA SUMMARY (MICROBIAL COMMUNITY AND CSIA)

| Sample ID | | PMLS4-2 | PMLS4-2 | PMLS4-2 | PMLS4-3 | PMLS4-3 | PMLS4-3 | PMLS4-4 | PMLS4-4 | PMLS4-5 | PMLS4-5 | PMLS4-6 | PMLS4-7 | PMLS5-1 |
|-----------------------------------|------|----------------|----------------|-----------------|----------------|----------------|----------------|----------------|----------------|-----------------|----------------|----------------|----------------|----------------|
| Sampling Date | | 3/10/2015 | 12/2/2015 | 8/1/2016 | 3/10/2015 | 12/2/2015 | 8/1/2016 | 3/10/2015 | 12/2/2015 | 3/11/2015 | 12/2/2015 | 3/11/2015 | 3/11/2015 | 3/12/2015 |
| MICROBIAL COMMUNITY | | cells/mL | cells/mL | cells/mL | cells/mL | cells/mL | cells/mL | cells/mL | cells/mL | cells/mL | cells/mL | cells/mL | cells/mL | cells/mL |
| Reductive Dechlorination | | | | | | | | | | | | | | |
| <i>Dehalococcoides</i> spp. | DHC | -- | -- | 9.62E+04 | -- | -- | -- | -- | -- | 1.05E+04 | -- | -- | -- | -- |
| tceA Reductase | TCE | -- | -- | -- | -- | -- | -- | -- | -- | 1.81E+03 | -- | -- | -- | -- |
| BAV1 Vinyl Chloride Reductase | BVC | -- | -- | -- | -- | -- | -- | -- | -- | 2.19E+03 | -- | -- | -- | -- |
| Vinyl Chloride Reductase | VCR | -- | -- | -- | -- | -- | -- | -- | -- | 6.11E+02 | -- | -- | -- | -- |
| <i>Dehalobacter</i> spp. | DHBt | -- | -- | -- | -- | -- | -- | -- | -- | 4.68E+03 | -- | -- | -- | -- |
| <i>Dehalobacter</i> DCM | DCM | -- | -- | -- | -- | -- | -- | -- | -- | 4.60E+00 U | -- | -- | -- | -- |
| <i>Dehalogenimonas</i> spp. | DHG | -- | -- | -- | -- | -- | -- | -- | -- | 3.77E+04 | -- | -- | -- | -- |
| <i>Desulfitobacterium</i> spp. | DSB | -- | -- | -- | -- | -- | -- | -- | -- | 5.13E+03 | -- | -- | -- | -- |
| <i>Dehalobium chlorocoercia</i> | DECO | -- | -- | -- | -- | -- | -- | -- | -- | 4.60E+00 U | -- | -- | -- | -- |
| <i>Desulfuromonas</i> spp. | DSM | -- | -- | -- | -- | -- | -- | -- | -- | 3.67E+03 | -- | -- | -- | -- |
| Chloroform reductase | CFR | -- | -- | -- | -- | -- | -- | -- | -- | 4.60E+00 U | -- | -- | -- | -- |
| 1,1-DCA Reductase | DCA | -- | -- | -- | -- | -- | -- | -- | -- | 4.60E+00 U | -- | -- | -- | -- |
| 1,2-DCA Reductase | DCAR | -- | -- | -- | -- | -- | -- | -- | -- | 4.60E+00 U | -- | -- | -- | -- |
| Aerobic Cometabolic | | | | | | | | | | | | | | |
| Soluble Methane Monooxygenase | SMMO | -- | -- | -- | -- | -- | -- | -- | -- | 1.88E+04 | -- | -- | -- | -- |
| Particulate Methane Monooxygenase | PMMO | -- | -- | -- | -- | -- | -- | -- | -- | 5.61E+03 | -- | -- | -- | -- |
| Toluene Dioxygenase | TOD | -- | -- | -- | -- | -- | -- | -- | -- | 1.01E+03 | -- | -- | -- | -- |
| Phenol Hydroxylase | PHE | -- | -- | -- | -- | -- | -- | -- | -- | 8.17E+03 | -- | -- | -- | -- |
| Trichlorobenzene Dioxygenase | TCBO | -- | -- | -- | -- | -- | -- | -- | -- | 8.09E+02 | -- | -- | -- | -- |
| Toluene Monooxygenase 2 | RDEG | -- | -- | -- | -- | -- | -- | -- | -- | 1.79E+03 | -- | -- | -- | -- |
| Toluene Monooxygenase | RMO | -- | -- | -- | -- | -- | -- | -- | -- | 1.26E+02 | -- | -- | -- | -- |
| Ethene Monooxygenase | EtnC | -- | -- | -- | -- | -- | -- | -- | -- | 1.40E+02 | -- | -- | -- | -- |
| Epoxyalkane transferase | EtnE | -- | -- | -- | -- | -- | -- | -- | -- | 5.04E+02 | -- | -- | -- | -- |
| Dichloromethane dehalogenase | DCMA | -- | -- | -- | -- | -- | -- | -- | -- | 4.60E+00 U | -- | -- | -- | -- |
| Other | | | | | | | | | | | | | | |
| Total Eubacteria | EBAC | -- | -- | -- | -- | -- | -- | -- | -- | 1.41E+06 | -- | -- | -- | -- |
| Sulfate Reducing Bacteria | APS | -- | -- | -- | -- | -- | -- | -- | -- | 6.37E+05 | -- | -- | -- | -- |
| Methanogens | MGN | -- | -- | -- | -- | -- | -- | -- | -- | 6.15E+02 | -- | -- | -- | -- |
| CSIA | | | | | | | | | | | | | | |
| | | $\delta^{13}C$ | $\delta^{13}C$ | $\delta^{13}C$ | $\delta^{13}C$ | $\delta^{13}C$ | $\delta^{13}C$ | $\delta^{13}C$ | $\delta^{13}C$ | $\delta^{13}C$ | $\delta^{13}C$ | $\delta^{13}C$ | $\delta^{13}C$ | $\delta^{13}C$ |
| Vinyl Chloride | | -- | -- | -23.42 | -- | -- | -- | -- | -- | -29.48 | -- | -- | -- | -- |
| cis-1,2-dichloroethene | | -- | -- | -8.17 | -- | -- | -- | -- | -- | -17.74 | -- | -- | -- | -- |
| Trichloroethene | | -- | -- | -16.39 | -- | -- | -- | -- | -- | -23.72 | -- | -- | -- | -- |

Notes:

BOLD value indicates the compound was detected above the reporting limit.

U indicates the compound was not detected at the indicated concentration.

J indicates the presence of a compound that meets the identification criteria. The result is less than the quantitation limit but greater than zero, and is given an approximate value.

-- indicates analysis was not performed

J*(CSIA): Target analyte produced a low weak signal; the result is considered usable to +/- 2 o/oo but not the standard +/- 0.5 o/oo

U* (CSIA): Either there was no peak corresponding to the target analyte or that such a peak did not produce a reliable CSIA result.

APPENDIX D.2: GROUNDWATER ANALYTICAL DATA SUMMARY (MICROBIAL COMMUNITY AND CSIA)

| Sample ID | | PMLS5-1 | PMLS5-2 | PMLS5-2 | PMLS5-3 | PMLS5-3 | PMLS5-4 | PMLS5-4 | PMLS5-5 | PMLS5-6 | PMLS5-7 | PMLS6-1 | PMLS6-2 |
|-----------------------------------|------|-----------------------|-----------------------|-----------------------|-----------------------|-----------------------|-----------------------|-----------------------|-----------------------|-----------------------|-----------------------|-----------------------|-----------------------|
| Sampling Date | | 12/2/2015 | 3/12/2015 | 12/2/2015 | 3/12/2015 | 12/2/2015 | 3/12/2015 | 12/2/2015 | 3/12/2015 | 3/12/2015 | 3/12/2015 | 3/11/2015 | 3/11/2015 |
| MICROBIAL COMMUNITY | | cells/mL | cells/mL | cells/mL | cells/mL | cells/mL | cells/mL | cells/mL | cells/mL | cells/mL | cells/mL | cells/mL | cells/mL |
| Reductive Dechlorination | | | | | | | | | | | | | |
| <i>Dehalococcoides</i> spp. | DHC | -- | -- | -- | -- | -- | -- | -- | -- | -- | -- | -- | -- |
| tceA Reductase | TCE | -- | -- | -- | -- | -- | -- | -- | -- | -- | -- | -- | -- |
| BAV1 Vinyl Chloride Reductase | BVC | -- | -- | -- | -- | -- | -- | -- | -- | -- | -- | -- | -- |
| Vinyl Chloride Reductase | VCR | -- | -- | -- | -- | -- | -- | -- | -- | -- | -- | -- | -- |
| <i>Dehalobacter</i> spp. | DHBt | -- | -- | -- | -- | -- | -- | -- | -- | -- | -- | -- | -- |
| <i>Dehalobacter</i> DCM | DCM | -- | -- | -- | -- | -- | -- | -- | -- | -- | -- | -- | -- |
| <i>Dehalogenimonas</i> spp. | DHG | -- | -- | -- | -- | -- | -- | -- | -- | -- | -- | -- | -- |
| <i>Desulfitobacterium</i> spp. | DSB | -- | -- | -- | -- | -- | -- | -- | -- | -- | -- | -- | -- |
| <i>Dehalobium chlorocoercia</i> | DECO | -- | -- | -- | -- | -- | -- | -- | -- | -- | -- | -- | -- |
| <i>Desulfuromonas</i> spp. | DSM | -- | -- | -- | -- | -- | -- | -- | -- | -- | -- | -- | -- |
| Chloroform reductase | CFR | -- | -- | -- | -- | -- | -- | -- | -- | -- | -- | -- | -- |
| 1,1-DCA Reductase | DCA | -- | -- | -- | -- | -- | -- | -- | -- | -- | -- | -- | -- |
| 1,2-DCA Reductase | DCAR | -- | -- | -- | -- | -- | -- | -- | -- | -- | -- | -- | -- |
| Aerobic Cometabolic | | | | | | | | | | | | | |
| Soluble Methane Monooxygenase | SMMO | -- | -- | -- | -- | -- | -- | -- | -- | -- | -- | -- | -- |
| Particulate Methane Monooxygenase | PMMO | -- | -- | -- | -- | -- | -- | -- | -- | -- | -- | -- | -- |
| Toluene Dioxygenase | TOD | -- | -- | -- | -- | -- | -- | -- | -- | -- | -- | -- | -- |
| Phenol Hydroxylase | PHE | -- | -- | -- | -- | -- | -- | -- | -- | -- | -- | -- | -- |
| Trichlorobenzene Dioxygenase | TCBO | -- | -- | -- | -- | -- | -- | -- | -- | -- | -- | -- | -- |
| Toluene Monooxygenase 2 | RDEG | -- | -- | -- | -- | -- | -- | -- | -- | -- | -- | -- | -- |
| Toluene Monooxygenase | RMO | -- | -- | -- | -- | -- | -- | -- | -- | -- | -- | -- | -- |
| Ethene Monooxygenase | EtnC | -- | -- | -- | -- | -- | -- | -- | -- | -- | -- | -- | -- |
| Epoxyalkane transferase | EtnE | -- | -- | -- | -- | -- | -- | -- | -- | -- | -- | -- | -- |
| Dichloromethane dehalogenase | DCMA | -- | -- | -- | -- | -- | -- | -- | -- | -- | -- | -- | -- |
| Other | | | | | | | | | | | | | |
| Total Eubacteria | EBAC | -- | -- | -- | -- | -- | -- | -- | -- | -- | -- | -- | -- |
| Sulfate Reducing Bacteria | APS | -- | -- | -- | -- | -- | -- | -- | -- | -- | -- | -- | -- |
| Methanogens | MGN | -- | -- | -- | -- | -- | -- | -- | -- | -- | -- | -- | -- |
| CSIA | | $\delta^{13}\text{C}$ | $\delta^{13}\text{C}$ | $\delta^{13}\text{C}$ | $\delta^{13}\text{C}$ | $\delta^{13}\text{C}$ | $\delta^{13}\text{C}$ | $\delta^{13}\text{C}$ | $\delta^{13}\text{C}$ | $\delta^{13}\text{C}$ | $\delta^{13}\text{C}$ | $\delta^{13}\text{C}$ | $\delta^{13}\text{C}$ |
| Vinyl Chloride | | -- | -- | -- | -- | -- | -- | -- | -- | -- | -- | -- | -- |
| cis-1,2-dichloroethene | | -- | -- | -- | -- | -- | -- | -- | -- | -- | -- | -- | -- |
| Trichloroethene | | -- | -- | -- | -- | -- | -- | -- | -- | -- | -- | -- | -- |

Notes:

BOLD value indicates the compound was detected above the reporting limit.

U indicates the compound was not detected at the indicated concentration.

J indicates the presence of a compound that meets the identification criteria. The result is less than the quantitation limit but greater than zero, and is given an approximate value.

-- indicates analysis was not performed

J*(CSIA): Target analyte produced a low weak signal; the result is considered usable to +/- 2 o/oo but not the standard +/- 0.5 o/oo

U* (CSIA): Either there was no peak corresponding to the target analyte or that such a peak did not produce a reliable CSIA result.

APPENDIX D.2: GROUNDWATER ANALYTICAL DATA SUMMARY (MICROBIAL COMMUNITY AND CSIA)

| Sample ID | | PMLS6-3 | PMLS6-4 | PMLS6-5 | PMLS6-6 | PMLS6-7 |
|-----------------------------------|------|----------------|----------------|----------------|----------------|----------------|
| Sampling Date | | 3/11/2015 | 3/12/2015 | 3/12/2015 | 3/12/2015 | 3/12/2015 |
| MICROBIAL COMMUNITY | | cells/mL | cells/mL | cells/mL | cells/mL | cells/mL |
| Reductive Dechlorination | | | | | | |
| <i>Dehalococcoides</i> spp. | DHC | -- | -- | -- | -- | -- |
| tceA Reductase | TCE | -- | -- | -- | -- | -- |
| BAV1 Vinyl Chloride Reductase | BVC | -- | -- | -- | -- | -- |
| Vinyl Chloride Reductase | VCR | -- | -- | -- | -- | -- |
| <i>Dehalobacter</i> spp. | DHBt | -- | -- | -- | -- | -- |
| <i>Dehalobacter</i> DCM | DCM | -- | -- | -- | -- | -- |
| <i>Dehalogenimonas</i> spp. | DHG | -- | -- | -- | -- | -- |
| <i>Desulfitobacterium</i> spp. | DSB | -- | -- | -- | -- | -- |
| <i>Dehalobium chlorocoercia</i> | DECO | -- | -- | -- | -- | -- |
| <i>Desulfuromonas</i> spp. | DSM | -- | -- | -- | -- | -- |
| Chloroform reductase | CFR | -- | -- | -- | -- | -- |
| 1,1-DCA Reductase | DCA | -- | -- | -- | -- | -- |
| 1,2-DCA Reductase | DCAR | -- | -- | -- | -- | -- |
| Aerobic Cometabolic | | | | | | |
| Soluble Methane Monooxygenase | SMMO | -- | -- | -- | -- | -- |
| Particulate Methane Monooxygenase | PMMO | -- | -- | -- | -- | -- |
| Toluene Dioxygenase | TOD | -- | -- | -- | -- | -- |
| Phenol Hydroxylase | PHE | -- | -- | -- | -- | -- |
| Trichlorobenzene Dioxygenase | TCBO | -- | -- | -- | -- | -- |
| Toluene Monooxygenase 2 | RDEG | -- | -- | -- | -- | -- |
| Toluene Monooxygenase | RMO | -- | -- | -- | -- | -- |
| Ethene Monooxygenase | EtnC | -- | -- | -- | -- | -- |
| Epoxyalkane transferase | EtnE | -- | -- | -- | -- | -- |
| Dichloromethane dehalogenase | DCMA | -- | -- | -- | -- | -- |
| Other | | | | | | |
| Total Eubacteria | EBAC | -- | -- | -- | -- | -- |
| Sulfate Reducing Bacteria | APS | -- | -- | -- | -- | -- |
| Methanogens | MGN | -- | -- | -- | -- | -- |
| CSIA | | $\delta^{13}C$ | $\delta^{13}C$ | $\delta^{13}C$ | $\delta^{13}C$ | $\delta^{13}C$ |
| Vinyl Chloride | | -- | -- | -- | -- | -- |
| cis-1,2-dichloroethene | | -- | -- | -- | -- | -- |
| Trichloroethene | | -- | -- | -- | -- | -- |

Notes:

BOLD value indicates the compound was detected above the reporting limit.

U indicates the compound was not detected at the indicated concentration.

J indicates the presence of a compound that meets the identification criteria. The result is less than the quantitation limit but greater than zero, and is given an approximate value.

-- indicates analysis was not performed

J*(CSIA): Target analyte produced a low weak signal; the result is considered usable to +/- 2 o/oo but not the standard +/- 0.5 o/oo

U* (CSIA): Either there was no peak corresponding to the target analyte or that such a peak did not produce a reliable CSIA result.

APPENDIX D.3: GROUNDWATER ANALYTICAL DATA SUMMARY (OTHER ANALYTICAL AND FIELD PARAMETERS)

| Sample ID | MW360-5 | MW360-5 | MW360-5 | SIW01 | SIW01 | SIW02 | SIW02 | SIW02 | SIW03 | SIW03 | SMLS1-1 | SMLS1-1 | SMLS1-1 |
|------------------------------|----------------|---------------|--------------|---------------|----------------|---------------|----------------|----------------|---------------|----------------|----------------|---------------|---------------|
| Sampling Date | 3/17/2015 | 12/9/2015 | 8/11/2016 | 3/16/2015 | 12/8/2015 | 3/16/2015 | 12/8/2015 | 8/11/2016 | 3/16/2015 | 12/8/2015 | 3/17/2015 | 12/3/2015 | 8/11/2016 |
| REDUCED GASES (GC) | µg/L | µg/L | µg/L | µg/L | µg/L | µg/L | µg/L | µg/L | µg/L | µg/L | µg/L | µg/L | µg/L |
| Methane | 2.0 U | 4.95 | 29.5 | 4610 D | 3300 | 3870 | 3520 | 10800 D | 5130 D | 3350 | 1450 | 1740 | 7400 D |
| Ethane | 4.0 U | 4.0 U | 4.0 U | 4.0 U | 4.0 U | 4.0 U | 4.0 U | 8.07 | 4.0 U | 4.0 U | 32.8 | 23.0 | 142 |
| Ethene | 5.0 U | 5.0 U | 5.0 U | 5.0 U | 5.0 U | 5.0 U | 5.0 U | 5.0 U | 5.0 U | 5.0 U | 662 | 370 | 2620 |
| Propane | 6.0 U | 6.0 U | 6.0 U | 6.0 U | 6.0 U | 6.0 U | 6.0 U | 6.0 U | 6.0 U | 6.0 U | 6.0 U | 6.0 U | 6.0 U |
| Acetylene | -- | 10.0 U | 10.0 U | -- | 10.0 U | -- | 10.0 U | 10.0 U | -- | 10.0 U | -- | 10.0 U | 10.0 U |
| OTHER GASES (GC) | µg/L | µg/L | µg/L | µg/L | µg/L | µg/L | µg/L | µg/L | µg/L | µg/L | µg/L | µg/L | µg/L |
| Hydrogen | 0.0084 U | -- | -- | 0.0084 U | -- | 0.0084 U | -- | -- | 0.0084 U | -- | 0.0084 U | -- | -- |
| METALS (DISSOLVED) | µg/L | µg/L | µg/L | µg/L | µg/L | µg/L | µg/L | µg/L | µg/L | µg/L | µg/L | µg/L | µg/L |
| Iron | 70.0 U | 70.0 U | -- | 814 | 536 | 936 | 611 | -- | 505 | 399 | 7160 | 5710 | -- |
| Manganese | 5.1 | 71.1 | -- | 899 | 871 | 806 | 583 | -- | 651 | 513 | 1060 | 713 | -- |
| GROUNDWATER CHEMISTRY | mg/L | mg/L | mg/L | mg/L | mg/L | mg/L | mg/L | mg/L | mg/L | mg/L | mg/L | mg/L | mg/L |
| Total Organic Carbon (TOC) | 7.80 | 16.8 | -- | 47.9 | 50.8 | 52.3 | 43.4 | -- | 32.4 | 37.5 | 16.6 | 20.2 | -- |
| ANIONS | mg/L | mg/L | mg/L | mg/L | mg/L | mg/L | mg/L | mg/L | mg/L | mg/L | mg/L | mg/L | mg/L |
| Chloride | 869 D | 510 D | 450 D | 953 D | 1030 D | 1190 D | 1050 D | 873 D | 1050 D | 983 D | 675 D | 1160 D | 770 D |
| Nitrite as N | 4.0 U | 4.0 U | 0.32 | 0.2 U | 4.0 U | 0.2 U | 4.0 U | 0.2 U | 0.2 U | 0.2 U | 4.0 U | 4.0 U | 0.2 U |
| Sulfate as SO ₄ | 119 D | 243 D | 218 D | 0.16 J | 1.95 JD | 0.18 J | 0.62 JD | 2.69 | 0.14 J | 0.94 JD | 149 D | 50.1 D | 126 D |
| Bromide | 2.69 JD | 4.01 D | 1.78 | 5.02 | 4.62 D | 5.20 | 4.90 D | 4.86 | 4.68 | 4.83 D | 1.82 JD | 6.01 D | 3.69 |
| Nitrate as N | 4.0 U | 4.0 U | 0.2 U | 0.2 U | 4.0 U | 0.2 U | 4.0 U | 0.2 U | 0.2 U | 0.2 U | 4.0 U | 4.0 U | 0.2 U |
| O-Phosphate as P | 4.0 U | 4.0 U | 0.2 U | 116 D | 108 D | 99.6 D | 66.8 D | 50.7 D | 131 D | 102 D | 5.4 | 4.0 U | 0.2 U |
| VOLATILE FATTY ACIDS | mg/L | mg/L | mg/L | mg/L | mg/L | mg/L | mg/L | mg/L | mg/L | mg/L | mg/L | mg/L | mg/L |
| Lactic Acid | 1.0 U | -- | -- | 1.0 U | -- | 1.0 U | -- | -- | 1.0 U | -- | 1.0 U | -- | -- |
| Acetic Acid | 1.0 U | -- | -- | 1.0 U | -- | 1.0 U | -- | -- | 1.0 U | -- | 1.0 U | -- | -- |
| Propionic Acid | 1.0 U | -- | -- | 1.0 U | -- | 1.0 U | -- | -- | 1.0 U | -- | 1.0 U | -- | -- |
| Formic Acid | 1.0 U | -- | -- | 1.0 U | -- | 1.0 U | -- | -- | 1.0 U | -- | 1.0 U | -- | -- |
| Butyric Acid | 1.0 U | -- | -- | 1.0 U | -- | 1.0 U | -- | -- | 1.0 U | -- | 1.0 U | -- | -- |
| Pyruvic Acid | 1.0 U | -- | -- | 1.0 U | -- | 1.0 U | -- | -- | 1.0 U | -- | 1.0 U | -- | -- |
| Valeric Acid | 1.0 U | -- | -- | 1.0 U | -- | 1.0 U | -- | -- | 1.0 U | -- | 1.0 U | -- | -- |
| FIELD PARAMETERS | | | | | | | | | | | | | |
| pH (SU) | 7.62 | 7.67 | 7.32 | 7.68 | 7.53 | 7.59 | 7.47 | 7.49 | 7.78 | 7.62 | 6.91 | 7.35 | 7.17 |
| Temperature (°C) | 16.91 | 18.85 | 23.52 | 22.66 | 21.59 | 22.26 | 21.74 | 22.87 | 22.77 | 21.53 | 18.63 | 16.59 | 21.03 |
| Dissolved Oxygen (DO; mg/L) | 1.44 | 1.92 | 1.19 | 1.30 | 0.58 | 1.74 | 0.49 | 2.38 | 1.99 | 0.47 | 2.55 | 2.86 | 2.97 |
| Redox Potential (ORP; mV) | 13.7 | 43.2 | 41.4 | -94.1 | -201.0 | -112.6 | -193.9 | -95.7 | -114.6 | -201.7 | -89.0 | -105.8 | -76.6 |
| Conductivity (µS/cm) | 3179 | 3043 | -- | 13571 | 10144 | 11437 | 8966 | -- | 13702 | 10287 | 2012 | 4604 | -- |
| Turbidity (NTU) | 238.19 | 126.38 | 93.02 | 87.37 | 126.91 | 118.27 | 45.66 | 16.44 | 55.46 | 11.49 | 28.33 | 16.75 | 7.67 |

Notes:

BOLD value indicates the compound was detected above the reporting limit.

U indicates the compound was not detected at the indicated concentration.

J indicates the presence of a compound that meets the identification criteria. The result is less than the quantitation limit but greater than zero, and is given an approximate value.

-- indicates analysis was not performed

D indicates the sample was diluted prior to analysis

APPENDIX D.3: GROUNDWATER ANALYTICAL DATA SUMMARY (OTHER ANALYTICAL AND FIELD PARAMETERS)

| Sample ID | SMLS1-2 | SMLS1-2 | SMLS1-2 | SMLS1-3 | SMLS1-3 | SMLS1-3 | SMLS1-4 | SMLS1-4 | SMLS1-4 | SMLS1-5 | SMLS1-5 | SMLS1-5 | SMLS1-6 |
|------------------------------|----------------|----------------|---------------|----------------|----------------|---------------|----------------|----------------|---------------|----------------|----------------|---------------|----------------|
| Sampling Date | 3/18/2015 | 12/3/2015 | 8/11/2016 | 3/17/2015 | 12/3/2015 | 8/11/2016 | 3/18/2015 | 12/3/2015 | 8/11/2016 | 3/18/2015 | 12/3/2015 | 8/11/2016 | 3/17/2015 |
| REDUCED GASES (GC) | µg/L | µg/L | µg/L | µg/L | µg/L | µg/L | µg/L | µg/L | µg/L | µg/L | µg/L | µg/L | µg/L |
| Methane | 3350 D | 1260 | 5410 D | 1910 | 1390 | 8180 D | 1530 | 473 | 3350 D | 834 | 261 | 1240 | 1230 |
| Ethane | 22.4 | 12.1 | 47.1 | 10.8 | 11.5 | 41.6 | 5.56 | 2.2 J | 12.3 | 2.28 J | 2.52 J | 2.78 | 2.75 J |
| Ethene | 535 | 330 | 1330 | 296 | 307 | 1640 | 59.8 | 39.9 | 140 | 5.01 | 6.65 | 4.07 | 10.20 |
| Propane | 6.0 U | 6.0 U | 6.0 U | 6.0 U | 6.0 U | 6.0 U | 6.0 U | 6.0 U | 6.0 U | 6.0 U | 6.0 U | 6.0 U | 6.0 U |
| Acetylene | -- | 10.0 U | 10.0 U | -- | 10.0 U | 10.0 U | -- | 10.0 U | 10.0 U | -- | 10.0 U | 10.0 U | -- |
| OTHER GASES (GC) | µg/L | µg/L | µg/L | µg/L | µg/L | µg/L | µg/L | µg/L | µg/L | µg/L | µg/L | µg/L | µg/L |
| Hydrogen | 0.0084 U | -- | -- | 0.0084 U | -- | -- | 0.0084 U | -- | -- | 0.0084 U | -- | -- | 0.0084 U |
| METALS (DISSOLVED) | µg/L | µg/L | µg/L | µg/L | µg/L | µg/L | µg/L | µg/L | µg/L | µg/L | µg/L | µg/L | µg/L |
| Iron | 4680 | 3120 | -- | 6730 | 4730 | -- | 3000 | 2170 | -- | 2550 | 1830 | -- | 2570 |
| Manganese | 708 | 532 | -- | 1290 | 947 | -- | 951 | 730 | -- | 692 | 446 | -- | 368 |
| GROUNDWATER CHEMISTRY | mg/L | mg/L | mg/L | mg/L | mg/L | mg/L | mg/L | mg/L | mg/L | mg/L | mg/L | mg/L | mg/L |
| Total Organic Carbon (TOC) | 43.7 | 19.5 | -- | 14.0 | 19.6 | -- | 2.63 | 16.5 | -- | 51.2 | 17.1 | -- | 10.9 |
| ANIONS | mg/L | mg/L | mg/L | mg/L | mg/L | mg/L | mg/L | mg/L | mg/L | mg/L | mg/L | mg/L | mg/L |
| Chloride | 874 D | 736 D | 643 D | 656 D | 739 D | 639 D | 761 D | 518 D | 443 D | 680 D | 453 D | 473 D | 1110 D |
| Nitrite as N | 4.0 U | 4.0 U | 0.2 U | 4.0 U | 4.0 U | 0.2 U | 4.0 U | 4.0 U | 0.2 U | 4.0 U | 4.0 U | 0.2 U | 4.0 U |
| Sulfate as SO ₄ | 123 D | 151 D | 134 D | 177 D | 151 D | 130 D | 172 D | 176 D | 161 D | 185 D | 178 D | 165 D | 130 D |
| Bromide | 2.59 JD | 3.15 JD | 2.95 | 1.57 JD | 3.55 JD | 2.77 | 2.24 JD | 1.96 JD | 1.83 | 1.52 JD | 1.61 JD | 1.57 | 3.87 JD |
| Nitrate as N | 4.0 U | 4.0 U | 0.2 U | 4.0 U | 4.0 U | 0.2 U | 4.0 U | 4.0 U | 0.2 U | 4.0 U | 9.19 | 0.2 U | 4.0 U |
| O-Phosphate as P | 4.0 U | 3.47 JD | 0.32 | 6.77 | 3.29 JD | 0.47 | 5.62 | 6.07 | 5.28 | 6.84 | 4.0 U | 6.37 | 4.0 U |
| VOLATILE FATTY ACIDS | mg/L | mg/L | mg/L | mg/L | mg/L | mg/L | mg/L | mg/L | mg/L | mg/L | mg/L | mg/L | mg/L |
| Lactic Acid | 1.0 U | -- | -- | 1.0 U | -- | -- | 1.0 U | -- | -- | 1.0 U | -- | -- | 1.0 U |
| Acetic Acid | 1.0 U | -- | -- | 1.0 U | -- | -- | 1.0 U | -- | -- | 1.0 U | -- | -- | 1.0 U |
| Propionic Acid | 1.0 U | -- | -- | 1.0 U | -- | -- | 1.0 U | -- | -- | 1.0 U | -- | -- | 1.0 U |
| Formic Acid | 1.0 U | -- | -- | 1.0 U | -- | -- | 1.0 U | -- | -- | 1.0 U | -- | -- | 1.0 U |
| Butyric Acid | 1.0 U | -- | -- | 1.0 U | -- | -- | 1.0 U | -- | -- | 1.0 U | -- | -- | 1.0 U |
| Pyruvic Acid | 1.0 U | -- | -- | 1.0 U | -- | -- | 1.0 U | -- | -- | 1.0 U | -- | -- | 1.0 U |
| Valeric Acid | 1.0 U | -- | -- | 1.0 U | -- | -- | 1.0 U | -- | -- | 1.0 U | -- | -- | 1.0 U |
| FIELD PARAMETERS | | | | | | | | | | | | | |
| pH (SU) | 6.93 | 7.23 | 7.05 | 7.01 | 7.17 | 6.87 | 7.24 | 7.41 | 7.03 | 7.31 | 7.37 | 7.37 | 7.28 |
| Temperature (°C) | 18.43 | 18.85 | 20.67 | 19.37 | 18.76 | 20.55 | 19.37 | 17.97 | 20.10 | 19.59 | 16.86 | 20.76 | 20.76 |
| Dissolved Oxygen (DO; mg/L) | 2.85 | 2.76 | 3.31 | 1.53 | 2.30 | 2.78 | 2.56 | 2.47 | 2.81 | 2.73 | 3.87 | 2.24 | 1.82 |
| Redox Potential (ORP; mV) | -78.5 | -129.8 | -93.9 | -109.6 | -115.2 | -97.5 | -118.2 | -122.0 | -95.9 | -123.5 | -102.3 | -129.4 | -124.2 |
| Conductivity (µS/cm) | 26339 | 3328 | -- | 5217 | 4225 | -- | 3584 | 3036 | -- | 32992 | 2764 | -- | 4772 |
| Turbidity (NTU) | 42.30 | 20.59 | 7.96 | 47.59 | 17.19 | 7.53 | 45.25 | 15.25 | 3.71 | 58.92 | 1.88 | 5.54 | 30.56 |

Notes:

BOLD value indicates the compound was detected above the reporting limit.

U indicates the compound was not detected at the indicated concentration.

J indicates the presence of a compound that meets the identification criteria. The result is less than the quantitation limit but greater than zero, and is given an approximate value.

-- indicates analysis was not performed

D indicates the sample was diluted prior to analysis

APPENDIX D.3: GROUNDWATER ANALYTICAL DATA SUMMARY (OTHER ANALYTICAL AND FIELD PARAMETERS)

| Sample ID | SMLS1-6 | SMLS1-6 | SMLS1-7 | SMLS1-7 | SMLS1-7 | SMLS2-1 | SMLS2-1 | SMLS2-1 | SMLS2-2 | SMLS2-2 | SMLS2-2 | SMLS2-3 | SMLS2-3 |
|-----------------------------|----------------|---------------|----------------|----------------|---------------|---------------|---------------|---------------|----------------|----------------|---------------|----------------|----------------|
| Sampling Date | 12/3/2015 | 8/11/2016 | 3/18/2015 | 12/3/2015 | 8/11/2016 | 3/24/2015 | 12/7/2015 | 8/3/2016 | 3/24/2015 | 12/7/2015 | 8/3/2016 | 3/24/2015 | 12/7/2015 |
| REDUCED GASES (GC) | µg/L | µg/L | µg/L | µg/L | µg/L | µg/L | µg/L | µg/L | µg/L | µg/L | µg/L | µg/L | µg/L |
| Methane | 492 | 2090 D | 13100 D | 1700 | 7380 D | 1970 | 562 | 103 | 3250 D | 514 | 843 | 1890 | 397 |
| Ethane | 3.53 JD | 4.31 | 23.2 | 2.92 JD | 10.5 | 30.7 | 8.00 | 1.52 J | 24.6 | 5.04 | 5.80 | 5.73 | 2.86 J |
| Ethene | 9.99 | 3.23 | 29.3 | 5.0 U | 1.88 J | 5.06 | 5.0 U | 5.0 U | 12.2 | 3.13 J | 3.40 J | 48.3 | 23.0 |
| Propane | 6.0 U | 6.0 U | 6.0 U | 6.0 U | 6.0 U | 6.0 U | 6.0 U | 6.0 U | 6.0 U | 6.0 U | 6.0 U | 6.0 U | 6.0 U |
| Acetylene | 10.0 U | 10.0 U | -- | 10.0 U | 10.0 U | -- | 10.0 U | 10.0 U | -- | 10.0 U | 10.0 U | -- | 10.0 U |
| OTHER GASES (GC) | µg/L | µg/L | µg/L | µg/L | µg/L | µg/L | µg/L | µg/L | µg/L | µg/L | µg/L | µg/L | µg/L |
| Hydrogen | -- | -- | 0.0278 | -- | -- | 0.0084 U | -- | -- | 0.0084 U | -- | -- | 0.0084 U | -- |
| METALS (DISSOLVED) | µg/L | µg/L | µg/L | µg/L | µg/L | µg/L | µg/L | µg/L | µg/L | µg/L | µg/L | µg/L | µg/L |
| Iron | 1650 | -- | 4440 | 2990 | -- | 3110 | 1260 | -- | 3480 | 2070 | -- | 2510 | 1390 |
| Manganese | 260 | -- | 237 | 162 | -- | 376 | 290 | -- | 443 | 362 | -- | 584 | 414 |
| GROUNDWATER CHEMISTRY | mg/L | mg/L | mg/L | mg/L | mg/L | mg/L | mg/L | mg/L | mg/L | mg/L | mg/L | mg/L | mg/L |
| Total Organic Carbon (TOC) | 15.7 | -- | 3.57 | 14.5 | -- | 28.1 | 26.8 | -- | 15.4 | 22.1 | -- | 11.6 | 19.0 |
| ANIONS | mg/L | mg/L | mg/L | mg/L | mg/L | mg/L | mg/L | mg/L | mg/L | mg/L | mg/L | mg/L | mg/L |
| Chloride | 618 D | 687 D | 1040 D | 1020 D | 954 D | 1100 D | 1240 D | 995 D | 676 D | 590 D | 493 D | 587 D | 462 D |
| Nitrite as N | 4.0 U | 0.2 U | 4.0 U | 4.0 U | 0.2 U | 4.0 U | 4.0 U | 0.2 U | 4.0 U | 4.0 U | 0.2 U | 4.0 U | 4.0 U |
| Sulfate as SO ₄ | 210 D | 236 D | 124 D | 225 D | 237 D | 6.76 D | 24.3 D | 39.7 | 141 D | 142 D | 136 D | 148 D | 175 D |
| Bromide | 2.15 JD | 2.49 | 3.41 JD | 4.60 D | 4.09 | 5.10 D | 6.37 D | 8.22 | 2.13 JD | 2.25 JD | 2.22 | 1.48 JD | 1.39 JD |
| Nitrate as N | 7.05 JD | 0.2 U | 4.0 U | 4.0 U | 0.2 U | 4.0 U | 4.0 U | 0.2 U | 4.0 U | 4.0 U | 0.2 U | 4.0 U | 4.0 U |
| O-Phosphate as P | 4.0 U | 5.23 | 5.44 | 5.03 D | 2.50 | 4.0 U | 4.0 U | 0.2 U | 5.74 D | 3.87 JD | 4.12 | 6.23 D | 4.43 D |
| VOLATILE FATTY ACIDS | mg/L | mg/L | mg/L | mg/L | mg/L | mg/L | mg/L | mg/L | mg/L | mg/L | mg/L | mg/L | mg/L |
| Lactic Acid | -- | -- | 1.0 U | -- | -- | 1.0 U | -- | -- | 1.0 U | -- | -- | 1.0 U | -- |
| Acetic Acid | -- | -- | 1.0 U | -- | -- | 1.0 U | -- | -- | 1.0 U | -- | -- | 1.0 U | -- |
| Propionic Acid | -- | -- | 1.0 U | -- | -- | 1.0 U | -- | -- | 1.0 U | -- | -- | 1.0 U | -- |
| Formic Acid | -- | -- | 1.0 U | -- | -- | 1.0 U | -- | -- | 1.0 U | -- | -- | 1.0 U | -- |
| Butyric Acid | -- | -- | 1.0 U | -- | -- | 1.0 U | -- | -- | 1.0 U | -- | -- | 1.0 U | -- |
| Pyruvic Acid | -- | -- | 1.0 U | -- | -- | 1.0 U | -- | -- | 1.0 U | -- | -- | 1.0 U | -- |
| Valeric Acid | -- | -- | 1.0 U | -- | -- | 1.0 U | -- | -- | 1.0 U | -- | -- | 1.0 U | -- |
| FIELD PARAMETERS | | | | | | | | | | | | | |
| pH (SU) | 7.40 | 7.15 | 7.32 | 7.43 | 7.10 | 6.74 | 7.25 | 7.13 | 7.05 | 7.21 | 6.46 | 7.22 | 7.38 |
| Temperature (°C) | 18.17 | 21.08 | 20.80 | 18.42 | 20.06 | 22.54 | 17.50 | 21.70 | 21.18 | 18.51 | 21.79 | 20.15 | 19.44 |
| Dissolved Oxygen (DO; mg/L) | 2.69 | 2.37 | 2.00 | 2.68 | 2.68 | 1.93 | 2.96 | 2.21 | 3.16 | 3.00 | 2.36 | 3.03 | 2.94 |
| Redox Potential (ORP; mV) | -123.0 | -121.5 | -131.2 | -127.8 | -106.6 | -76.1 | -86.1 | -110.8 | -102.2 | -104.4 | -55.0 | -91.8 | -120.4 |
| Conductivity (µS/cm) | 3688 | -- | 5464 | 5455 | -- | 62 | 4176 | -- | 4310 | 3527 | -- | 3890 | 2816 |
| Turbidity (NTU) | 14.25 | 16.10 | 127.91 | 43.29 | 103.3 | 18.36 | 26.77 | 16.00 | 25.20 | 9.24 | 9.86 | 48.74 | 2.93 |

Notes:

BOLD value indicates the compound was detected above the reporting limit.

U indicates the compound was not detected at the indicated concentration.

J indicates the presence of a compound that meets the identification criteria. The result is less than the quantitation limit but greater than zero, and is given an approximate value.

-- indicates analysis was not performed

D indicates the sample was diluted prior to analysis

APPENDIX D.3: GROUNDWATER ANALYTICAL DATA SUMMARY (OTHER ANALYTICAL AND FIELD PARAMETERS)

| Sample ID | SMLS2-3 | SMLS2-4 | SMLS2-4 | SMLS2-4 | SMLS2-5 | SMLS2-5 | SMLS2-5 | SMLS2-6 | SMLS2-7 | SMLS3-1 | SMLS3-1 | SMLS3-2 | SMLS3-2 |
|-----------------------------|---------------|---------------|----------------|---------------|----------------|----------------|---------------|----------------|----------------|----------------|---------------|----------------|----------------|
| Sampling Date | 8/3/2016 | 3/24/2015 | 12/7/2015 | 8/3/2016 | 3/25/2015 | 12/7/2015 | 8/3/2016 | 3/25/2015 | 3/25/2015 | 3/25/2015 | 12/7/2015 | 3/25/2015 | 12/7/2015 |
| REDUCED GASES (GC) | µg/L | µg/L | µg/L | µg/L | µg/L | µg/L | µg/L | µg/L | µg/L | µg/L | µg/L | µg/L | µg/L |
| Methane | 610 | 1280 | 260 | 516 | 1600 | 192 | 215 | 3620 D | 4630 D | 1590 | 1090 | 3630 D | 377 |
| Ethane | 3.08 J | 2.50 J | 4.0 U | 1.18 J | 2.98 J | 1.81 J | 4.0 U | 2.35 J | 4.93 | 5.23 | 10.0 | 15.2 | 3.73 |
| Ethene | 32.4 | 13.1 | 6.15 | 6.97 | 5.0 U | 2.85 J | 5.0 U | 5.0 U | 5.0 U | 5.0 U | 4.66 J | 9.70 | 2.36 J |
| Propane | 6.0 U | 6.0 U | 6.0 U | 6.0 U | 6.0 U | 6.0 U | 6.0 U | 6.0 U | 6.0 U | 6.0 U | 6.0 U | 6.0 U | 6.0 U |
| Acetylene | 10.0 U | -- | 10.0 U | 10.0 U | -- | 10.0 U | 10.0 U | -- | -- | -- | 10.0 U | -- | 10.0 U |
| OTHER GASES (GC) | µg/L | µg/L | µg/L | µg/L | µg/L | µg/L | µg/L | µg/L | µg/L | µg/L | µg/L | µg/L | µg/L |
| Hydrogen | -- | 0.0084 U | -- | -- | 0.0084 U | -- | -- | 0.0084 U | 0.0084 U | 0.0084 U | -- | 0.0084 U | -- |
| METALS (DISSOLVED) | µg/L | µg/L | µg/L | µg/L | µg/L | µg/L | µg/L | µg/L | µg/L | µg/L | µg/L | µg/L | µg/L |
| Iron | -- | 3440 | 2110 | -- | 3220 | 1770 | -- | 5760 | 3890 | 4600 | 2650 | 6470 | 1820 |
| Manganese | -- | 927 | 563 | -- | 632 | 328 | -- | 522 | 96.6 | 204 | 196 | 635 | 247 |
| GROUNDWATER CHEMISTRY | mg/L | mg/L | mg/L | mg/L | mg/L | mg/L | mg/L | mg/L | mg/L | mg/L | mg/L | mg/L | mg/L |
| Total Organic Carbon (TOC) | -- | 11.2 | 19.2 | -- | 10.9 | 18.9 | -- | 10.5 | 14.9 | 19.5 | 23.2 | 20.5 | 21.5 |
| ANIONS | mg/L | mg/L | mg/L | mg/L | mg/L | mg/L | mg/L | mg/L | mg/L | mg/L | mg/L | mg/L | mg/L |
| Chloride | 493 D | 662 D | 422 D | 411 D | 567 D | 454 D | 485 D | 681 D | 821 D | 807 D | 881 D | 867 D | 552 D |
| Nitrite as N | 0.2 U | 4.0 U | 4.0 U | 0.2 U | 4.0 U | 4.0 U | 0.2 U | 4.0 U | 4.0 U | 4.0 U | 4.0 U | 4.0 U | 4.0 U |
| Sulfate as SO ₄ | 154 D | 179 D | 175 D | 167 D | 140 D | 182 D | 183 D | 137 D | 97.0 D | 22.6 D | 90.5 D | 21.6 D | 133 D |
| Bromide | 2.90 | 4.0 JD | 1.23 JD | 1.62 | 1.37 JD | 1.22 JD | 1.62 | 1.91 JD | 2.77 JD | 3.10 JD | 4.22 D | 3.45 JD | 2.09 JD |
| Nitrate as N | 0.2 U | 4.0 U | 4.0 U | 0.2 U | 4.0 U | 4.0 U | 0.2 U | 4.0 U | 4.0 U | 4.0 U | 4.0 U | 4.0 U | 4.0 U |
| O-Phosphate as P | 5.18 | 7.08 D | 5.96 D | 5.58 | 5.95 | 5.80 D | 5.60 | 5.49 | 5.49 | 4.0 U | 4.0 U | 4.0 U | 3.86 JD |
| VOLATILE FATTY ACIDS | mg/L | mg/L | mg/L | mg/L | mg/L | mg/L | mg/L | mg/L | mg/L | mg/L | mg/L | mg/L | mg/L |
| Lactic Acid | -- | 1.0 U | -- | -- | 1.0 U | -- | -- | 1.0 U | 1.0 U | 1.0 U | -- | 1.0 U | -- |
| Acetic Acid | -- | 1.0 U | -- | -- | 1.0 U | -- | -- | 1.0 U | 1.0 U | 1.0 U | -- | 1.0 U | -- |
| Propionic Acid | -- | 1.0 U | -- | -- | 1.0 U | -- | -- | 1.0 U | 1.0 U | 1.0 U | -- | 1.0 U | -- |
| Formic Acid | -- | 1.0 U | -- | -- | 1.0 U | -- | -- | 1.0 U | 1.0 U | 1.0 U | -- | 1.0 U | -- |
| Butyric Acid | -- | 1.0 U | -- | -- | 1.0 U | -- | -- | 1.0 U | 1.0 U | 1.0 U | -- | 1.0 U | -- |
| Pyruvic Acid | -- | 1.0 U | -- | -- | 1.0 U | -- | -- | 1.0 U | 1.0 U | 1.0 U | -- | 1.0 U | -- |
| Valeric Acid | -- | 1.0 U | -- | -- | 1.0 U | -- | -- | 1.0 U | 1.0 U | 1.0 U | -- | 1.0 U | -- |
| FIELD PARAMETERS | | | | | | | | | | | | | |
| pH (SU) | 7.21 | 7.17 | 7.38 | 7.17 | 7.12 | 7.38 | 7.18 | 7.07 | 7.22 | 6.86 | 7.04 | 6.90 | 7.14 |
| Temperature (°C) | 21.58 | 20.06 | 19.41 | 21.52 | 19.16 | 19.81 | 21.54 | 19.15 | 19.52 | 21.82 | 20.05 | 20.84 | 20.02 |
| Dissolved Oxygen (DO; mg/L) | 2.88 | 2.79 | 2.68 | 2.57 | 2.68 | 2.95 | 2.65 | 2.25 | 2.32 | 2.17 | 3.01 | 2.56 | 2.93 |
| Redox Potential (ORP; mV) | -130.9 | -113.3 | -127.2 | -129.9 | -108.2 | -117.3 | -124.4 | -118.6 | -114.6 | -89.2 | -96.7 | -95.0 | -98.5 |
| Conductivity (µS/cm) | -- | 3810 | 2718 | -- | 4279 | 2666 | -- | 5103 | 6668 | 6672 | 2968 | 6213 | 2327 |
| Turbidity (NTU) | 3.79 | 42.82 | 7.81 | 20.02 | 34.42 | 11.42 | 39.43 | 16.49 | 20.09 | 34.13 | 4.43 | 6.75 | 4.13 |

Notes:

BOLD value indicates the compound was detected above the reporting limit.

U indicates the compound was not detected at the indicated concentration.

J indicates the presence of a compound that meets the identification criteria. The result is less than the quantitation limit but greater than zero, and is given an approximate value.

-- indicates analysis was not performed

D indicates the sample was diluted prior to analysis

APPENDIX D.3: GROUNDWATER ANALYTICAL DATA SUMMARY (OTHER ANALYTICAL AND FIELD PARAMETERS)

| Sample ID | SMLS3-3 | SMLS3-3 | SMLS3-4 | SMLS3-4 | SMLS3-5 | SMLS3-6 | SMLS3-7 | SMLS4-1 | SMLS4-1 | SMLS4-1 | SMLS4-2 | SMLS4-2 | SMLS4-2 |
|-----------------------------|----------------|----------------|----------------|----------------|---------------|----------------|----------------|----------------|----------------|---------------|----------------|----------------|---------------|
| Sampling Date | 3/25/2015 | 12/7/2015 | 3/25/2015 | 12/7/2015 | 3/25/2015 | 3/25/2015 | 3/25/2015 | 3/26/2015 | 12/7/2015 | 8/2/2016 | 3/26/2015 | 12/7/2015 | 8/2/2016 |
| REDUCED GASES (GC) | µg/L | µg/L | µg/L | µg/L | µg/L | µg/L | µg/L | µg/L | µg/L | µg/L | µg/L | µg/L | µg/L |
| Methane | 3630 D | 514 | 2000 | 219 | 1220 | 1280 | 5960 D | 1960 | 945 | 13.7 | 3720 D | 1620 | 1830 |
| Ethane | 6.63 | 3.11 J | 2.01 J | 4.0 U | 4.0 U | 4.0 U | 4.19 | 67.1 | 48.3 | 4.0 U | 46.3 | 27.7 | 32.0 |
| Ethene | 5.0 U | 7.97 | 5.0 U | 11.8 | 5.0 U | 5.0 U | 5.0 U | 581 | 216 | 5.34 | 190 | 246 | 286 |
| Propane | 6.0 U | 6.0 U | 6.0 U | 6.0 U | 6.0 U | 6.0 U | 6.0 U | 4.96 J | 6.0 U | 6.0 U | 6.0 U | 6.0 U | 6.0 U |
| Acetylene | -- | 10.0 U | -- | 10.0 U | -- | -- | -- | -- | 10.0 U | 10.0 U | -- | 10.0 U | 10.0 U |
| OTHER GASES (GC) | µg/L | µg/L | µg/L | µg/L | µg/L | µg/L | µg/L | µg/L | µg/L | µg/L | µg/L | µg/L | µg/L |
| Hydrogen | 0.0084 U | -- | 0.0084 U | -- | 0.0084 U | 0.0084 U | 0.0084 U | 0.0084 U | -- | -- | 0.0084 U | -- | -- |
| METALS (DISSOLVED) | µg/L | µg/L | µg/L | µg/L | µg/L | µg/L | µg/L | µg/L | µg/L | µg/L | µg/L | µg/L | µg/L |
| Iron | 3210 | 664 | 3240 | 1980 | 4820 | 6120 | 5500 | 5610 | 2080 | -- | 3460 | 3360 | -- |
| Manganese | 597 | 367 | 1260 | 700 | 578 | 853 | 344 | 353 | 386 | -- | 936 | 866 | -- |
| GROUNDWATER CHEMISTRY | mg/L | mg/L | mg/L | mg/L | mg/L | mg/L | mg/L | mg/L | mg/L | mg/L | mg/L | mg/L | mg/L |
| Total Organic Carbon (TOC) | 16.7 | 19.7 | 13.5 | 19.3 | 11.3 | 11.6 | 15.4 | 22.4 | 33.5 | -- | 18.3 | 22.6 | -- |
| ANIONS | mg/L | mg/L | mg/L | mg/L | mg/L | mg/L | mg/L | mg/L | mg/L | mg/L | mg/L | mg/L | mg/L |
| Chloride | 699 D | 448 D | 538 D | 422 D | 473 D | 724 D | 918 D | 1270 ED | 1530 D | 1340 D | 1260 ED | 1500 D | 1320 D |
| Nitrite as N | 4.0 U | 4.0 U | 4.0 U | 4.0 U | 4.0 U | 7.52 | 4.0 U | 4.0 U | 4.0 U | 0.2 U | 4.0 U | 4.0 U | 0.2 U |
| Sulfate as SO ₄ | 85.9 D | 155 D | 147 D | 178 D | 144 D | 196 D | 115 D | 94.0 D | 46.2 D | 57.5 | 64.0 D | 123.0 D | 123 D |
| Bromide | 2.33 JD | 1.41 JD | 1.63 JD | 1.49 JD | 4.00 U | 2.70 JD | 2.46 JD | 9.73 D | 8.90 JD | 8.88 | 8.67 D | 9.61 D | 9.55 |
| Nitrate as N | 4.0 U | 4.0 U | 4.0 U | 4.0 U | 4.0 U | 25.3 | 4.0 U | 4.0 U | 4.0 U | 0.51 | 4.0 U | 4.0 U | 0.2 U |
| O-Phosphate as P | 5.53 | 4.02 D | 6.24 | 4.41 D | 6.87 | 4.0 U | 5.40 | 4.0 U | 4.0 U | 0.2 U | 4.0 U | 4.0 U | 0.2 U |
| VOLATILE FATTY ACIDS | mg/L | mg/L | mg/L | mg/L | mg/L | mg/L | mg/L | mg/L | mg/L | mg/L | mg/L | mg/L | mg/L |
| Lactic Acid | 1.0 U | -- | 1.0 U | -- | 1.0 U | 1.0 U | 1.0 U | 1.0 U | -- | -- | 1.0 U | -- | -- |
| Acetic Acid | 1.0 U | -- | 1.0 U | -- | 1.0 U | 1.0 U | 1.0 U | 1.0 U | -- | -- | 1.0 U | -- | -- |
| Propionic Acid | 1.0 U | -- | 1.0 U | -- | 1.0 U | 1.0 U | 1.0 U | 1.0 U | -- | -- | 1.0 U | -- | -- |
| Formic Acid | 1.0 U | -- | 1.0 U | -- | 1.0 U | 1.0 U | 1.0 U | 1.0 U | -- | -- | 1.0 U | -- | -- |
| Butyric Acid | 1.0 U | -- | 1.0 U | -- | 1.0 U | 1.0 U | 1.0 U | 1.0 U | -- | -- | 1.0 U | -- | -- |
| Pyruvic Acid | 1.0 U | -- | 1.0 U | -- | 1.0 U | 1.0 U | 1.0 U | 1.0 U | -- | -- | 1.0 U | -- | -- |
| Valeric Acid | 1.0 U | -- | 1.0 U | -- | 1.0 U | 1.0 U | 1.0 U | 1.0 U | -- | -- | 1.0 U | -- | -- |
| FIELD PARAMETERS | | | | | | | | | | | | | |
| pH (SU) | 6.97 | 7.21 | 7.12 | 7.34 | 6.99 | 6.92 | 7.11 | 6.94 | 7.21 | 8.42 | 6.91 | 7.21 | 6.97 |
| Temperature (°C) | 20.50 | 20.19 | 20.67 | 20.34 | 22.26 | 23.13 | 23.35 | 18.76 | 22.76 | 21.65 | 20.22 | 22.39 | 22.83 |
| Dissolved Oxygen (DO; mg/L) | 2.16 | 2.61 | 2.22 | 1.95 | 2.06 | 22.90 | 2.17 | 1.95 | 1.75 | 8.60 | 2.19 | 2.59 | 1.99 |
| Redox Potential (ORP; mV) | -94.8 | -118.4 | -108.7 | -136.0 | -111.7 | -108.5 | -109.3 | -90.0 | -155.4 | -96.2 | -105.1 | -165.0 | -15.3 |
| Conductivity (µS/cm) | 5451 | 2762 | 3993 | 2625 | 3549 | 4493 | 6804 | 6836 | 7377 | -- | 6680 | 6719 | -- |
| Turbidity (NTU) | 18.42 | 7.16 | 15.96 | 17.50 | 11.43 | 25.30 | 12.23 | 26.76 | 27.47 | 4.28 | 22.68 | 15.89 | 65.55 |

Notes:

BOLD value indicates the compound was detected above the reporting limit.

U indicates the compound was not detected at the indicated concentration.

J indicates the presence of a compound that meets the identification criteria. The result is less than the quantitation limit but greater than zero, and is given an approximate value.

-- indicates analysis was not performed

D indicates the sample was diluted prior to analysis

APPENDIX D.3: GROUNDWATER ANALYTICAL DATA SUMMARY (OTHER ANALYTICAL AND FIELD PARAMETERS)

| Sample ID | SMLS4-3 | SMLS4-3 | SMLS4-3 | SMLS4-4 | SMLS4-4 | SMLS4-4 | SMLS4-5 | SMLS4-5 | SMLS4-5 | SMLS4-6 | SMLS4-6 | SMLS4-7 | SMLS4-7 |
|------------------------------|---------------|---------------|---------------|---------------|----------------|--------------|---------------|----------------|--------------|---------------|---------------|---------------|--------------|
| Sampling Date | 3/26/2015 | 12/7/2015 | 8/2/2016 | 3/26/2015 | 12/7/2015 | 8/2/2016 | 3/26/2015 | 12/7/2015 | 8/2/2016 | 3/26/2015 | 8/2/2016 | 3/26/2015 | 8/2/2016 |
| REDUCED GASES (GC) | µg/L | µg/L | µg/L | µg/L | µg/L | µg/L | µg/L | µg/L | µg/L | µg/L | µg/L | µg/L | µg/L |
| Methane | 4670 D | 1590 | 1940 | 4660 D | 1330 | 771 | 6250 D | 940 | 623 | 6080 D | 1170 | 5610 D | 2770 |
| Ethane | 57.9 | 49.2 | 34.9 | 29.1 | 17.9 | 6.31 | 40.5 | 13.4 | 5.43 | 14.7 | 2.81 J | 15.1 | 4.40 |
| Ethene | 55.5 | 107 | 405 | 256 | 113 | 157 | 50.8 | 6.36 | 58.8 | 7.87 | 2.33 J | 7.41 | 5.0 U |
| Propane | 6.0 U | 6.0 U | 6.0 U | 6.0 U | 6.0 U | 6.0 U | 6.0 U | 6.0 U | 6.0 U | 6.0 U | 6.0 U | 6.0 U | 6.0 U |
| Acetylene | -- | 10.0 U | 10.0 U | -- | 10.0 U | 10.0 U | -- | 10.0 U | 10.0 U | -- | 10.0 U | -- | 10.0 U |
| OTHER GASES (GC) | µg/L | µg/L | µg/L | µg/L | µg/L | µg/L | µg/L | µg/L | µg/L | µg/L | µg/L | µg/L | µg/L |
| Hydrogen | 0.0084 U | -- | -- | 0.0084 U | -- | -- | 0.0084 U | -- | -- | 0.0084 U | -- | 0.0084 U | -- |
| METALS (DISSOLVED) | µg/L | µg/L | µg/L | µg/L | µg/L | µg/L | µg/L | µg/L | µg/L | µg/L | µg/L | µg/L | µg/L |
| Iron | 4680 | 3520 | -- | 2100 | 1860 | -- | 1710 | 809 | -- | 2040 | -- | 3320 | -- |
| Manganese | 1160 | 933 | -- | 484 | 419 | -- | 471 | 267 | -- | 428 | -- | 135 | -- |
| GROUNDWATER CHEMISTRY | mg/L | mg/L | mg/L | mg/L | mg/L | mg/L | mg/L | mg/L | mg/L | mg/L | mg/L | mg/L | mg/L |
| Total Organic Carbon (TOC) | 19.9 | 27.0 | -- | 12.2 | 21.2 | -- | 13.3 | 21.3 | -- | 11.9 | -- | 16.2 | -- |
| ANIONS | mg/L | mg/L | mg/L | mg/L | mg/L | mg/L | mg/L | mg/L | mg/L | mg/L | mg/L | mg/L | mg/L |
| Chloride | 1100 D | 1360 D | 1190 D | 794 D | 707 D | 598 D | 736 D | 582 D | 516 D | 696 D | 664 D | 1010 D | 898 D |
| Nitrite as N | 4.0 U | 4.0 U | 0.2 U | 4.0 U | 4.0 U | 0.2 U | 4.0 U | 4.0 U | 0.2 U | 4.0 U | 0.2 U | 4.0 U | 0.2 U |
| Sulfate as SO ₄ | 23.0 D | 32.7 D | 90.5 D | 102 D | 166 D | 150 D | 80.0 D | 151 D | 135 D | 105 D | 186 D | 67.0 D | 162 D |
| Bromide | 5.46 D | 8.04 D | 8.60 | 4.92 D | 2.53 JD | 2.75 | 4.22 D | 1.79 JD | 2.08 | 4.17 D | 2.84 | 6.13 D | 2.92 |
| Nitrate as N | 4.0 U | 4.0 U | 0.2 U | 4.0 U | 4.0 U | 0.2 U | 4.0 U | 4.0 U | 0.2 U | 4.0 U | 0.2 U | 4.0 U | 0.2 U |
| O-Phosphate as P | 4.0 U | 4.0 U | 0.2 U | 4.0 U | 3.35 JD | 1.57 | 4.0 U | 4.17 JD | 3.26 | 4.0 U | 3.67 | 4.0 U | 2.59 |
| VOLATILE FATTY ACIDS | mg/L | mg/L | mg/L | mg/L | mg/L | mg/L | mg/L | mg/L | mg/L | mg/L | mg/L | mg/L | mg/L |
| Lactic Acid | 1.0 U | -- | -- | 1.0 U | -- | -- | 1.0 U | -- | -- | 1.0 U | -- | 1.0 U | -- |
| Acetic Acid | 1.0 U | -- | -- | 1.0 U | -- | -- | 1.0 U | -- | -- | 1.0 U | -- | 1.0 U | -- |
| Propionic Acid | 1.0 U | -- | -- | 1.0 U | -- | -- | 1.0 U | -- | -- | 1.0 U | -- | 1.0 U | -- |
| Formic Acid | 1.0 U | -- | -- | 1.0 U | -- | -- | 1.0 U | -- | -- | 1.0 U | -- | 1.0 U | -- |
| Butyric Acid | 1.0 U | -- | -- | 1.0 U | -- | -- | 1.0 U | -- | -- | 1.0 U | -- | 1.0 U | -- |
| Pyruvic Acid | 1.0 U | -- | -- | 1.0 U | -- | -- | 1.0 U | -- | -- | 1.0 U | -- | 1.0 U | -- |
| Valeric Acid | 1.0 U | -- | -- | 1.0 U | -- | -- | 1.0 U | -- | -- | 1.0 U | -- | 1.0 U | -- |
| FIELD PARAMETERS | | | | | | | | | | | | | |
| pH (SU) | 6.98 | 7.25 | 7.07 | 7.11 | 7.28 | 7.08 | 7.13 | 7.35 | 7.30 | 7.19 | 7.17 | 7.19 | 7.29 |
| Temperature (°C) | 20.58 | 22.64 | 22.19 | 21.41 | 20.99 | 23.23 | 21.34 | 21.05 | 23.31 | 22.00 | 23.25 | 22.40 | 22.26 |
| Dissolved Oxygen (DO; mg/L) | 2.30 | 2.80 | 1.94 | 2.23 | 2.34 | 2.40 | 1.89 | 2.25 | 1.85 | 1.85 | 1.90 | 1.42 | 2.10 |
| Redox Potential (ORP; mV) | -101.4 | -140.6 | -21.1 | -106.7 | -129.5 | -21.4 | -115.3 | -206.7 | -33.8 | -115.8 | -26.5 | -110.4 | -33.3 |
| Conductivity (µS/cm) | 6802 | 6416 | -- | 5146 | 3954 | -- | 4829 | 3541 | -- | 5198 | -- | 7403 | -- |
| Turbidity (NTU) | 32.32 | 13.57 | 19.53 | 28.86 | 32.17 | 24.97 | 82.95 | 8.26 | 7.02 | 23.46 | 5.87 | 27.49 | 15.66 |

Notes:

BOLD value indicates the compound was detected above the reporting limit.

U indicates the compound was not detected at the indicated concentration.

J indicates the presence of a compound that meets the identification criteria. The result is less than the quantitation limit but greater than zero, and is given an approximate value.

-- indicates analysis was not performed

D indicates the sample was diluted prior to analysis

APPENDIX D.3: GROUNDWATER ANALYTICAL DATA SUMMARY (OTHER ANALYTICAL AND FIELD PARAMETERS)

| Sample ID | SMLS5-1 | SMLS5-1 | SMLS5-2 | SMLS5-2 | SMLS5-3 | SMLS5-3 | SMLS5-4 | SMLS5-4 | SMLS5-5 | SMLS5-5 | SMLS5-6 | SMLS5-6 | SMLS5-7 |
|-----------------------------|---------------|---------------|----------------|----------------|----------------|----------------|----------------|----------------|----------------|----------------|----------------|----------------|----------------|
| Sampling Date | 3/17/2015 | 12/15/2015 | 3/18/2015 | 12/15/2015 | 3/17/2015 | 12/15/2015 | 3/18/2015 | 12/15/2015 | 3/18/2015 | 12/15/2015 | 3/17/2015 | 12/15/2015 | 3/18/2015 |
| REDUCED GASES (GC) | µg/L | µg/L | µg/L | µg/L | µg/L | µg/L | µg/L | µg/L | µg/L | µg/L | µg/L | µg/L | µg/L |
| Methane | 1940 | 1110 | 10300 D | 1650 | 1590 | 1080 | 5200 D | 700 | 796 | 597 | 327 | 397 | 12400 D |
| Ethane | 4.05 | 2.8 J | 20.9 | 2.8 J | 4.0 U | 1.7 J | 8.10 | 1.05 J | 3.04 J | 4.0 U | 4.0 U | 4.0 U | 13.3 |
| Ethene | 5.0 U | 5.0 U | 5.0 U | 5.0 U | 5.0 U | 5.0 U | 5.0 U | 5.0 U | 5.0 U | 5.0 U | 5.0 U | 5.0 U | 5.0 U |
| Propane | 6.0 U | 6.0 U | 6.0 U | 6.0 U | 6.0 U | 6.0 U | 6.0 U | 6.0 U | 6.0 U | 6.0 U | 6.0 U | 6.0 U | 6.0 U |
| Acetylene | -- | 10.0 U | -- | 10.0 U | -- | 10.0 U | -- | 10.0 U | -- | 10.0 U | -- | 10.0 U | -- |
| OTHER GASES (GC) | µg/L | µg/L | µg/L | µg/L | µg/L | µg/L | µg/L | µg/L | µg/L | µg/L | µg/L | µg/L | µg/L |
| Hydrogen | 0.0104 | -- | 0.0084 U | -- | 0.0084 U | -- | 0.0084 U | -- | 0.0084 U | -- | 0.0084 U | -- | 0.0612 |
| METALS (DISSOLVED) | µg/L | µg/L | µg/L | µg/L | µg/L | µg/L | µg/L | µg/L | µg/L | µg/L | µg/L | µg/L | µg/L |
| Iron | 8840 | 5560 | 5720 | 4320 | 4910 | 3050 | 3370 | 2380 | 1530 | 1010 | 2360 | 1190 | 1820 |
| Manganese | 960 | 446 | 379 | 334 | 768 | 596 | 717 | 509 | 502 | 364 | 552 | 370 | 82.4 |
| GROUNDWATER CHEMISTRY | mg/L | mg/L | mg/L | mg/L | mg/L | mg/L | mg/L | mg/L | mg/L | mg/L | mg/L | mg/L | mg/L |
| Total Organic Carbon (TOC) | 23.1 | 29.4 | 17.9 | 31.0 | 15.4 | 20.7 | 14.5 | 19.3 | 11.1 | 19.9 | 10.5 | 18.9 | 7.19 |
| ANIONS | mg/L | mg/L | mg/L | mg/L | mg/L | mg/L | mg/L | mg/L | mg/L | mg/L | mg/L | mg/L | mg/L |
| Chloride | 1150 D | 1370 D | 1090 D | 1200 D | 704 D | 881 D | 680 D | 642 D | 651 D | 541 D | 615 D | 645 D | 1090 D |
| Nitrite as N | 4.0 U | 4.0 U | 4.0 U | 4.0 U | 4.0 U | 4.0 U | 4.0 U | 4.0 U | 4.0 U | 4.0 U | 4.0 U | 4.0 U | 4.0 U |
| Sulfate as SO ₄ | 24.0 D | 22.5 D | 22.2 D | 23.7 D | 165 D | 115 D | 157 D | 193 D | 189 D | 190 D | 177 D | 205 D | 94.9 D |
| Bromide | 4.29 D | 6.57 D | 4.17 D | 5.17 D | 1.94 JD | 3.93 JD | 2.02 JD | 2.43 JD | 1.47 JD | 2.61 JD | 1.24 JD | 2.01 JD | 4.08 JD |
| Nitrate as N | 4.0 U | 4.0 U | 4.0 U | 4.0 U | 4.0 U | 4.0 U | 4.0 U | 4.0 U | 4.0 U | 4.0 U | 4.0 U | 4.0 U | 4.0 U |
| O-Phosphate as P | 4.0 U | 4.0 U | 5.28 | 3.37 JD | 5.94 D | 5.13 D | 6.77 | 7.39 D | 8.26 | 9.10 D | 7.40 D | 9.19 D | 7.65 |
| VOLATILE FATTY ACIDS | mg/L | mg/L | mg/L | mg/L | mg/L | mg/L | mg/L | mg/L | mg/L | mg/L | mg/L | mg/L | mg/L |
| Lactic Acid | 1.0 U | -- | 1.0 U | -- | 1.0 U | -- | 1.0 U | -- | 0.75 J | -- | 1.0 U | -- | 1.0 U |
| Acetic Acid | 1.0 U | -- | 1.0 U | -- | 1.0 U | -- | 1.0 U | -- | 1.0 U | -- | 1.0 U | -- | 1.0 U |
| Propionic Acid | 1.0 U | -- | 1.0 U | -- | 1.0 U | -- | 1.0 U | -- | 1.0 U | -- | 1.0 U | -- | 1.0 U |
| Formic Acid | 1.0 U | -- | 1.0 U | -- | 1.0 U | -- | 1.0 U | -- | 1.0 U | -- | 1.0 U | -- | 1.0 U |
| Butyric Acid | 1.0 U | -- | 1.0 U | -- | 1.0 U | -- | 1.0 U | -- | 1.0 U | -- | 1.0 U | -- | 1.0 U |
| Pyruvic Acid | 1.0 U | -- | 1.0 U | -- | 1.0 U | -- | 1.0 U | -- | 1.0 U | -- | 1.0 U | -- | 1.0 U |
| Valeric Acid | 1.0 U | -- | 1.0 U | -- | 1.0 U | -- | 1.0 U | -- | 1.0 U | -- | 1.0 U | -- | 1.0 U |
| FIELD PARAMETERS | | | | | | | | | | | | | |
| pH (SU) | 7.11 | 5.68 | 7.17 | 5.89 | 7.15 | 5.88 | 7.28 | 5.95 | 7.11 | 5.86 | 7.31 | 5.90 | 7.44 |
| Temperature (°C) | 21.88 | 19.06 | 21.01 | 18.66 | 22.19 | 18.98 | 21.37 | 18.91 | 20.56 | 18.85 | 22.02 | 19.34 | 20.80 |
| Dissolved Oxygen (DO; mg/L) | 1.05 | 1.98 | 1.91 | 2.19 | 1.98 | 1.81 | 2.75 | 1.88 | 1.63 | 2.38 | 1.73 | 1.96 | 1.42 |
| Redox Potential (ORP; mV) | -109.3 | 726.8 | -134.5 | -114.0 | -117.6 | -118.0 | -120.4 | -117.7 | -83.6 | -123.2 | -126.6 | -108.0 | -120.6 |
| Conductivity (µS/cm) | 8808 | 9364 | 67717 | 7670 | 4308 | 4712 | 37062 | 39.08 | 34365 | 3374 | 4028 | 3606 | 66783 |
| Turbidity (NTU) | 85.38 | 67.45 | 145.11 | 76.73 | 22.03 | 50.05 | 30.63 | 220.70 | 21.15 | 6769 | 60.30 | 175.93 | 71.93 |

Notes:

BOLD value indicates the compound was detected above the reporting limit.

U indicates the compound was not detected at the indicated concentration.

J indicates the presence of a compound that meets the identification criteria. The result is less than the quantitation limit but greater than zero, and is given an approximate value.

-- indicates analysis was not performed

D indicates the sample was diluted prior to analysis

APPENDIX D.3: GROUNDWATER ANALYTICAL DATA SUMMARY (OTHER ANALYTICAL AND FIELD PARAMETERS)

| Sample ID | SMLS6-1 | SMLS6-2 | SMLS6-3 | SMLS6-4 | SMLS6-5 | SMLS6-6 | SMLS6-7 | SMLS7-1 | SMLS7-1 | SMLS7-1 | SMLS7-2 | SMLS7-2 | SMLS7-2 |
|------------------------------|----------------|---------------|----------------|----------------|----------------|----------------|----------------|----------------|---------------|---------------|---------------|---------------|--------------|
| Sampling Date | 3/24/2015 | 3/24/2015 | 3/24/2015 | 3/24/2015 | 3/24/2015 | 3/24/2015 | 3/24/2015 | 3/17/2015 | 12/8/2015 | 8/3/2016 | 3/23/2015 | 12/8/2015 | 8/3/2016 |
| REDUCED GASES (GC) | µg/L | µg/L | µg/L | µg/L | µg/L | µg/L | µg/L | µg/L | µg/L | µg/L | µg/L | µg/L | µg/L |
| Methane | 1550 | 1960 | 2190 | 4650 D | 2120 | 3110 D | 4240 D | 1990 | 1550 | 2100 | 1550 | 2140 | 2060 |
| Ethane | 2.94 J | 1.62 J | 8.79 | 2.80 J | 1.94 J | 2.25 J | 4.0 U | 32.5 | 18.9 | 16.3 | 34.0 | 41.0 | 32.0 |
| Ethene | 5.0 U | 5.0 U | 5.0 U | 5.0 U | 5.0 U | 5.0 U | 5.0 U | 5.0 U | 5.0 U | 5.0 U | 5.0 U | 5.0 U | 5.0 U |
| Propane | 6.0 U | 6.0 U | 6.0 U | 6.0 U | 6.0 U | 6.0 U | 6.0 U | 6.0 U | 6.0 U | 6.0 U | 6.0 U | 6.0 U | 6.0 U |
| Acetylene | -- | -- | -- | -- | -- | -- | -- | -- | 10.0 U | 10.0 U | -- | 10.0 U | 10.0 U |
| OTHER GASES (GC) | µg/L | µg/L | µg/L | µg/L | µg/L | µg/L | µg/L | µg/L | µg/L | µg/L | µg/L | µg/L | µg/L |
| Hydrogen | 0.0084 U | 0.0084 U | 0.0084 U | 0.0084 U | 0.0084 U | 0.0084 U | 0.0084 U | 0.0084 U | 0.2090 | 0.0084 U | -- | 0.0084 U | -- |
| METALS (DISSOLVED) | µg/L | µg/L | µg/L | µg/L | µg/L | µg/L | µg/L | µg/L | µg/L | µg/L | µg/L | µg/L | µg/L |
| Iron | 2960 | 194 | 3220 | 1620 | 972 | 853 | 3620 | 6010 | 5180 | -- | 7940 | 5170 | -- |
| Manganese | 1730 | 1010 | 1050 | 534 | 830 | 443 | 979 | 521 | 344 | -- | 1450 | 1350 | -- |
| GROUNDWATER CHEMISTRY | mg/L | mg/L | mg/L | mg/L | mg/L | mg/L | mg/L | mg/L | mg/L | mg/L | mg/L | mg/L | mg/L |
| Total Organic Carbon (TOC) | 22.2 | 34.8 | 28.9 | 9.80 | 14.5 | 24.6 | 21.3 | 13.1 | 19.0 | -- | 19.0 | 22.5 | -- |
| ANIONS | mg/L | mg/L | mg/L | mg/L | mg/L | mg/L | mg/L | mg/L | mg/L | mg/L | mg/L | mg/L | mg/L |
| Chloride | 823 D | 1090 D | 827 D | 656 D | 516 D | 693 D | 682 D | 1140 ED | 1180 D | 1120 D | 965 D | 1200 D | 983 D |
| Nitrite as N | 4.0 U | 4.0 U | 4.0 U | 4.0 U | 4.0 U | 4.0 U | 4.0 U | 4.0 U | 4.0 U | 4.0 U | 0.2 U | 4.0 U | 4.0 U |
| Sulfate as SO ₄ | 8.68 D | 8.41 D | 27.3 D | 87.1 D | 108 D | 101 D | 19.7 D | 100 D | 79.4 D | 91.9 D | 11.8 D | 40.0 D | 42.7 |
| Bromide | 3.84 JD | 5.43 D | 3.28 JD | 2.09 JD | 1.46 JD | 2.00 JD | 2.65 JD | 4.19 D | 6.48 D | 7.57 | 4.05 D | 6.55 D | 5.97 |
| Nitrate as N | 4.0 U | 4.0 U | 4.0 U | 4.0 U | 4.0 U | 4.0 U | 4.0 U | 4.0 U | 4.0 U | 4.0 U | 0.2 U | 4.0 U | 4.0 U |
| O-Phosphate as P | 4.0 U | 6.68 D | 8.00 D | 10.2 D | 9.11 D | 18.9 D | 7.82 D | 7.37 D | 4.0 U | 0.2 U | 4.0 U | 4.0 U | 0.2 U |
| VOLATILE FATTY ACIDS | mg/L | mg/L | mg/L | mg/L | mg/L | mg/L | mg/L | mg/L | mg/L | mg/L | mg/L | mg/L | mg/L |
| Lactic Acid | 1.0 U | 1.0 U | 1.0 U | 1.0 U | 1.0 U | 1.0 U | 1.0 U | 1.0 U | 1.0 U | -- | -- | 1.0 U | -- |
| Acetic Acid | 1.0 U | 1.0 U | 1.0 U | 1.0 U | 1.0 U | 1.0 U | 1.0 U | 1.0 U | 1.0 U | -- | -- | 1.0 U | -- |
| Propionic Acid | 1.0 U | 1.0 U | 1.0 U | 1.0 U | 1.0 U | 1.0 U | 1.0 U | 1.0 U | 1.0 U | -- | -- | 1.0 U | -- |
| Formic Acid | 1.0 U | 1.0 U | 1.0 U | 1.0 U | 1.0 U | 1.0 U | 1.0 U | 1.0 U | 1.0 U | -- | -- | 1.0 U | -- |
| Butyric Acid | 1.0 U | 1.0 U | 1.0 U | 1.0 U | 1.0 U | 1.0 U | 1.0 U | 1.0 U | 1.0 U | -- | -- | 1.0 U | -- |
| Pyruvic Acid | 1.0 U | 1.0 U | 1.0 U | 1.0 U | 1.0 U | 1.0 U | 1.0 U | 1.0 U | 1.0 U | -- | -- | 1.0 U | -- |
| Valeric Acid | 1.0 U | 1.0 U | 1.0 U | 1.0 U | 1.0 U | 1.0 U | 1.0 U | 1.0 U | 1.0 U | -- | -- | 1.0 U | -- |
| FIELD PARAMETERS | | | | | | | | | | | | | |
| pH (SU) | 7.27 | 8.20 | 7.81 | 8.18 | 7.31 | 7.94 | 7.14 | 7.07 | 7.19 | 6.98 | 7.08 | 7.13 | 6.98 |
| Temperature (°C) | 18.21 | 19.06 | 19.46 | 21.28 | 20.70 | 21.28 | 21.05 | 22.47 | 17.47 | 21.26 | 17.90 | 18.58 | 20.94 |
| Dissolved Oxygen (DO; mg/L) | 2.07 | 0.15 | 0.11 | 0.20 | 0.48 | 0.21 | 1.42 | 1.48 | 3.10 | 1.66 | 2.46 | 2.50 | 2.27 |
| Redox Potential (ORP; mV) | -98.2 | -261.4 | -284.7 | -265.7 | -173.4 | -212.2 | -132.1 | -107.9 | -92.2 | -15.9 | -92.7 | -117.7 | -15.3 |
| Conductivity (µS/cm) | 3470 | 75938 | 9105 | 12839 | 5779 | 10066 | 3672 | 6341 | 5713 | -- | 49694 | 5578 | -- |
| Turbidity (NTU) | 75.11 | 119.45 | 63.24 | 107.91 | 176.33 | 198.58 | 159.79 | 119.35 | 11.87 | 5.77 | 46.51 | 10.28 | 7.60 |

Notes:

BOLD value indicates the compound was detected above the reporting limit.

U indicates the compound was not detected at the indicated concentration.

J indicates the presence of a compound that meets the identification criteria. The result is less than the quantitation limit but greater than zero, and is given an approximate value.

-- indicates analysis was not performed

D indicates the sample was diluted prior to analysis

APPENDIX D.3: GROUNDWATER ANALYTICAL DATA SUMMARY (OTHER ANALYTICAL AND FIELD PARAMETERS)

| Sample ID | SMLS7-3 | SMLS7-3 | SMLS7-3 | SMLS7-4 | SMLS7-4 | SMLS7-4 | SMLS7-5 | SMLS7-5 | SMLS7-5 | SMLS7-6 | SMLS7-7 | SMLS8-1 | SMLS8-1 |
|-----------------------------|---------------|---------------|--------------|----------------|----------------|--------------|----------------|----------------|---------------|---------------|---------------|---------------|---------------|
| Sampling Date | 3/17/2015 | 12/8/2015 | 8/3/2016 | 3/23/2015 | 12/8/2015 | 8/3/2016 | 3/23/2015 | 12/8/2015 | 8/3/2016 | 3/17/2015 | 3/23/2015 | 3/23/2015 | 12/8/2015 |
| REDUCED GASES (GC) | µg/L | µg/L | µg/L | µg/L | µg/L | µg/L | µg/L | µg/L | µg/L | µg/L | µg/L | µg/L | µg/L |
| Methane | 2190 | 1680 | 1970 | 2220 | 1620 | 1420 | 2100 | 389 | 276 | 2290 | 2260 | 1480 | 531 |
| Ethane | 19.2 | 14.5 | 22.3 | 23.3 | 19.2 | 27.8 | 5.11 | 4.06 | 3.92 J | 4.02 | 6.15 | 5.71 | 3.40 J |
| Ethene | 274 | 196 | 229 | 15.8 | 10.0 | 31.2 | 5.0 U | 2.38 J | 5.0 U | 4.01 J | 5.0 U | 5.0 U | 5.0 U |
| Propane | 6.0 U | 6.0 U | 6.0 U | 6.0 U | 6.0 U | 6.0 U | 6.0 U | 6.0 U | 6.0 U | 6.0 U | 6.0 U | 6.0 U | 6.0 U |
| Acetylene | -- | 10.0 U | 10.0 U | -- | 10.0 U | 10.0 U | -- | 10.0 U | 10.0 U | -- | -- | -- | 10.0 U |
| OTHER GASES (GC) | µg/L | µg/L | µg/L | µg/L | µg/L | µg/L | µg/L | µg/L | µg/L | µg/L | µg/L | µg/L | µg/L |
| Hydrogen | 0.0084 U | -- | -- | 0.0084 U | -- | -- | 0.0084 U | -- | -- | 0.0084 U | 0.0084 U | 0.0084 U | -- |
| METALS (DISSOLVED) | µg/L | µg/L | µg/L | µg/L | µg/L | µg/L | µg/L | µg/L | µg/L | µg/L | µg/L | µg/L | µg/L |
| Iron | 4050 | 2910 | -- | 4180 | 2330 | -- | 2120 | 904 | -- | 3540 | 2500 | 7040 | 5460 |
| Manganese | 1530 | 1310 | -- | 672 | 400 | -- | 368 | 248 | -- | 949 | 169 | 710 | 613 |
| GROUNDWATER CHEMISTRY | mg/L | mg/L | mg/L | mg/L | mg/L | mg/L | mg/L | mg/L | mg/L | mg/L | mg/L | mg/L | mg/L |
| Total Organic Carbon (TOC) | 13.8 | 18.5 | -- | 17.7 | 17.4 | -- | 15.1 | 19.0 | -- | 12.0 | 20.7 | 17.9 | 22.4 |
| ANIONS | mg/L | mg/L | mg/L | mg/L | mg/L | mg/L | mg/L | mg/L | mg/L | mg/L | mg/L | mg/L | mg/L |
| Chloride | 747 D | 1070 D | 768 D | 642 D | 561 D | 476 D | 601 D | 440 D | 435 D | 580 D | 1020 D | 1060 D | 1200 D |
| Nitrite as N | 4.0 U | 4.0 U | 0.2 U | 4.0 U | 4.0 U | 0.2 U | 4.0 U | 4.0 U | 0.2 U | 4.0 U | 4.0 U | 4.0 U | 4.0 U |
| Sulfate as SO ₄ | 17.6 D | 62.1 D | 55.5 | 27.3 D | 117 D | 68.7 | 122 D | 155 D | 159 D | 129 D | 22.8 D | 78.0 D | 128 D |
| Bromide | 5.22 D | 5.38 D | 4.84 | 2.55 JD | 2.10 JD | 2.49 | 1.90 JD | 1.25 JD | 1.70 | 4.0 U | 4.49 D | 5.03 D | 6.85 D |
| Nitrate as N | 4.0 U | 4.0 U | 0.2 U | 4.0 U | 4.0 U | 0.2 U | 4.0 U | 4.0 U | 0.2 U | 4.0 U | 4.0 U | 4.0 U | 4.0 U |
| O-Phosphate as P | 4.0 U | 4.0 U | 0.2 U | 4.0 U | 3.23 JD | 0.35 | 5.41 D | 4.96 D | 4.15 | 4.0 U | 5.18 D | 4.75 D | 4.0 U |
| VOLATILE FATTY ACIDS | mg/L | mg/L | mg/L | mg/L | mg/L | mg/L | mg/L | mg/L | mg/L | mg/L | mg/L | mg/L | mg/L |
| Lactic Acid | 1.0 U | -- | -- | 1.0 U | -- | -- | 1.0 U | -- | -- | 1.0 U | 1.0 U | 1.0 U | -- |
| Acetic Acid | 1.0 U | -- | -- | 1.0 U | -- | -- | 1.0 U | -- | -- | 1.0 U | 1.0 U | 1.0 U | -- |
| Propionic Acid | 1.0 U | -- | -- | 1.0 U | -- | -- | 1.0 U | -- | -- | 1.0 U | 1.0 U | 1.0 U | -- |
| Formic Acid | 1.0 U | -- | -- | 1.0 U | -- | -- | 1.0 U | -- | -- | 1.0 U | 1.0 U | 1.0 U | -- |
| Butyric Acid | 1.0 U | -- | -- | 1.0 U | -- | -- | 1.0 U | -- | -- | 1.0 U | 1.0 U | 1.0 U | -- |
| Pyruvic Acid | 1.0 U | -- | -- | 1.0 U | -- | -- | 1.0 U | -- | -- | 1.0 U | 1.0 U | 1.0 U | -- |
| Valeric Acid | 1.0 U | -- | -- | 1.0 U | -- | -- | 1.0 U | -- | -- | 1.0 U | 1.0 U | 1.0 U | -- |
| FIELD PARAMETERS | | | | | | | | | | | | | |
| pH (SU) | 6.80 | 7.03 | 6.28 | 6.61 | 7.07 | 5.58 | 7.15 | 6.96 | 7.12 | 7.23 | 7.28 | 7.17 | 7.11 |
| Temperature (°C) | 21.62 | 19.05 | 21.47 | 18.48 | 18.57 | 21.77 | 19.51 | 19.16 | 21.36 | 21.10 | 21.04 | 20.55 | 20.39 |
| Dissolved Oxygen (DO; mg/L) | 1.94 | 2.46 | 2.92 | 2.97 | 3.18 | 2.72 | 2.53 | 3.39 | 2.70 | 1.95 | 2.36 | 2.31 | 3.43 |
| Redox Potential (ORP; mV) | -75.2 | -101.3 | 23.8 | -54.1 | -123.7 | 64.2 | -98.9 | -134.9 | -107.1 | -117.3 | -103.8 | -132.8 | -143.3 |
| Conductivity (µS/cm) | 4321 | 4973 | -- | 15865 | 2924 | -- | 31590 | 2105 | -- | 4396 | 55241 | 59173 | 6149 |
| Turbidity (NTU) | 42.08 | 25.12 | 5.24 | 48.00 | 9.03 | 3.53 | 76.75 | 9.12 | 40.95 | 107.07 | 46.46 | 25.34 | 28.25 |

Notes:

BOLD value indicates the compound was detected above the reporting limit.

U indicates the compound was not detected at the indicated concentration.

J indicates the presence of a compound that meets the identification criteria. The result is less than the quantitation limit but greater than zero, and is given an approximate value.

-- indicates analysis was not performed

D indicates the sample was diluted prior to analysis

APPENDIX D.3: GROUNDWATER ANALYTICAL DATA SUMMARY (OTHER ANALYTICAL AND FIELD PARAMETERS)

| Sample ID | SMLS8-2 | SMLS8-2 | SMLS8-3 | SMLS8-3 | SMLS8-4 | SMLS8-4 | SMLS8-5 | SMLS8-6 | SMLS8-7 | SPW-1 | SPW3-1 | SPW3-2 | PEW01 |
|-----------------------------|----------------|----------------|----------------|----------------|----------------|----------------|----------------|----------------|----------------|--------------|---------------|---------------|---------------|
| Sampling Date | 3/23/2015 | 12/8/2015 | 3/23/2015 | 12/8/2015 | 3/23/2015 | 12/8/2015 | 3/23/2015 | 3/23/2015 | 3/23/2015 | 8/11/2016 | 8/11/2016 | 8/11/2016 | 3/16/2015 |
| REDUCED GASES (GC) | µg/L | µg/L | µg/L | µg/L | µg/L | µg/L | µg/L | µg/L | µg/L | µg/L | µg/L | µg/L | µg/L |
| Methane | 922 | 204 | 1110 | 123 | 1550 | 210 | 7030 D | 3750 D | 5500 D | 2100 | 4990 D | 5400 D | 4610 D |
| Ethane | 3.09 J | 1.75 J | 4.0 U | 4.0 U | 1.71 J | 2.22 J | 4.0 U | 4.0 U | 6.23 | 16.3 | 393 | 176 | 9.41 |
| Ethene | 5.0 U | 5.0 U | 5.0 U | 5.0 U | 5.0 U | 3.43 J | 5.0 U | 5.0 U | 5.0 U | 66.8 | 437 | 4090 D | 18.4 |
| Propane | 6.0 U | 6.0 U | 6.0 U | 6.0 U | 6.0 U | 6.0 U | 6.0 U | 6.0 U | 6.0 U | 6.0 U | 6.0 U | 6.0 U | 6.0 U |
| Acetylene | -- | 10.0 U | -- | 10.0 U | -- | 10.0 U | -- | -- | -- | 10.0 U | 10.0 U | 10.0 U | -- |
| OTHER GASES (GC) | µg/L | µg/L | µg/L | µg/L | µg/L | µg/L | µg/L | µg/L | µg/L | µg/L | µg/L | µg/L | µg/L |
| Hydrogen | 0.0084 U | -- | 0.0084 U | -- | 0.0084 U | -- | 0.0084 U | 0.0084 U | 0.0084 U | -- | -- | -- | 0.0084 U |
| METALS (DISSOLVED) | µg/L | µg/L | µg/L | µg/L | µg/L | µg/L | µg/L | µg/L | µg/L | µg/L | µg/L | µg/L | µg/L |
| Iron | 4800 | 2500 | 3680 | 2040 | 3410 | 1820 | 2740 | 5980 | 5250 | -- | -- | -- | 6420 |
| Manganese | 969 | 644 | 992 | 634 | 1130 | 649 | 856 | 1740 | 489 | -- | -- | -- | 874 |
| GROUNDWATER CHEMISTRY | mg/L | mg/L | mg/L | mg/L | mg/L | mg/L | mg/L | mg/L | mg/L | mg/L | mg/L | mg/L | mg/L |
| Total Organic Carbon (TOC) | 17.1 | 20.0 | 14.5 | 19.7 | 14.9 | 18.5 | 12.6 | 13.4 | 18.8 | -- | -- | -- | 15.3 |
| ANIONS | mg/L | mg/L | mg/L | mg/L | mg/L | mg/L | mg/L | mg/L | mg/L | mg/L | mg/L | mg/L | mg/L |
| Chloride | 870 D | 789 D | 725 D | 548 D | 682 D | 510 D | 511 D | 792 D | 887 D | 772 D | 320 D | 250 D | 819 D |
| Nitrite as N | 4.0 U | 4.0 U | 4.0 U | 4.0 U | 4.0 U | 4.0 U | 4.0 U | 4.0 U | 4.0 U | 4.0 U | 0.2 U | 0.2 U | 0.2 U |
| Sulfate as SO ₄ | 104 D | 147 D | 136 D | 176 D | 142 D | 178 D | 143 D | 178 D | 130 D | 161 D | 21.1 | 47.7 | 135 D |
| Bromide | 3.68 JD | 3.76 JD | 2.81 JD | 2.02 JD | 2.50 JD | 1.80 JD | 1.35 JD | 2.51 JD | 3.09 JD | 4.06 | 1.62 | 0.96 | 4.15 |
| Nitrate as N | 4.0 U | 4.0 U | 4.0 U | 4.0 U | 4.0 U | 4.0 U | 4.0 U | 4.0 U | 4.0 U | 4.0 U | 0.2 U | 0.2 U | 0.2 U |
| O-Phosphate as P | 4.0 U | 4.0 U | 4.0 U | 3.89 JD | 4.0 U | 3.94 JD | 4.0 U | 4.0 U | 4.0 U | 0.55 | 0.2 U | 0.88 | 0.2 U |
| VOLATILE FATTY ACIDS | mg/L | mg/L | mg/L | mg/L | mg/L | mg/L | mg/L | mg/L | mg/L | mg/L | mg/L | mg/L | mg/L |
| Lactic Acid | 1.0 U | -- | 1.0 U | -- | 1.0 U | -- | 1.0 U | 1.0 U | 1.0 U | 1.0 U | -- | -- | 1.0 U |
| Acetic Acid | 1.0 U | -- | 1.0 U | -- | 1.0 U | -- | 1.0 U | 1.0 U | 1.0 U | 1.0 U | -- | -- | 1.0 U |
| Propionic Acid | 1.0 U | -- | 1.0 U | -- | 1.0 U | -- | 1.0 U | 1.0 U | 1.0 U | 1.0 U | -- | -- | 1.0 U |
| Formic Acid | 1.0 U | -- | 1.0 U | -- | 1.0 U | -- | 1.0 U | 1.0 U | 1.0 U | 1.0 U | -- | -- | 1.0 U |
| Butyric Acid | 1.0 U | -- | 1.0 U | -- | 1.0 U | -- | 1.0 U | 1.0 U | 1.0 U | 1.0 U | -- | -- | 1.0 U |
| Pyruvic Acid | 1.0 U | -- | 1.0 U | -- | 1.0 U | -- | 1.0 U | 1.0 U | 1.0 U | 1.0 U | -- | -- | 1.0 U |
| Valeric Acid | 1.0 U | -- | 1.0 U | -- | 1.0 U | -- | 1.0 U | 1.0 U | 1.0 U | 1.0 U | -- | -- | 1.0 U |
| FIELD PARAMETERS | | | | | | | | | | | | | |
| pH (SU) | 7.30 | 7.36 | 7.22 | 7.29 | 7.34 | 7.35 | 7.20 | 7.20 | 7.32 | 6.86 | 6.72 | 7.59 | 7.11 |
| Temperature (°C) | 20.29 | 20.81 | 19.94 | 20.08 | 20.21 | 20.23 | 20.22 | 20.73 | 21.32 | 21.20 | 20.38 | 20.42 | 20.07 |
| Dissolved Oxygen (DO; mg/L) | 3.31 | 2.89 | 2.37 | 2.54 | 3.26 | 2.73 | 2.00 | 1.25 | 1.63 | 3.27 | 4.56 | 3.88 | 0.26 |
| Redox Potential (ORP; mV) | -98.9 | -171.8 | -109.1 | -188.4 | -101.7 | -189.5 | -107.7 | -138.9 | -153.8 | -30.1 | -53.4 | -115.5 | -133.5 |
| Conductivity (µS/cm) | 47588 | 4058 | 38899 | 3223 | 41026 | 3150 | 25049 | 38878 | 56998 | -- | -- | -- | 4945 |
| Turbidity (NTU) | 9.61 | 17.48 | 6.24 | 7.16 | 49.09 | 7.19 | 45.51 | 46.38 | 78.04 | 48.16 | 69.64 | 95.32 | 185.82 |

Notes:

BOLD value indicates the compound was detected above the reporting limit.

U indicates the compound was not detected at the indicated concentration.

J indicates the presence of a compound that meets the identification criteria. The result is less than the quantitation limit but greater than zero, and is given an approximate value.

-- indicates analysis was not performed

D indicates the sample was diluted prior to analysis

APPENDIX D.3: GROUNDWATER ANALYTICAL DATA SUMMARY (OTHER ANALYTICAL AND FIELD PARAMETERS)

| Sample ID | PEW01 | PEW01 | PEW02 | PEW02 | PEW02 | PEW03 | PEW03 | PEW03 | PEW04 | PEW04 | PEW04 | PMLS1-1 | PMLS1-1 |
|------------------------------|----------------|--------------|---------------|---------------|---------------|---------------|----------------|---------------|---------------|----------------|--------------|---------------|---------------|
| Sampling Date | 12/9/2015 | 8/2/2016 | 3/16/2015 | 12/9/2015 | 8/11/2016 | 3/16/2015 | 12/9/2015 | 8/1/2016 | 3/16/2015 | 12/9/2015 | 8/1/2016 | 3/9/2015 | 12/1/2015 |
| REDUCED GASES (GC) | µg/L | µg/L | µg/L | µg/L | µg/L | µg/L | µg/L | µg/L | µg/L | µg/L | µg/L | µg/L | µg/L |
| Methane | 1560 | 1950 | 5970 D | 1360 | 1330 | 3160 D | 2830 | 975 | 999 | 3210 | 22.4 | 625 | 345 |
| Ethane | 10.7 | 14.9 | 5.48 | 3.16 J | 3.97 J | 3.12 J | 3.45 J | 1.27 J | 4.0 U | 4.0 U | 4.0 U | 6.88 | 6.7 |
| Ethene | 13.8 | 270 | 42.2 | 31.0 | 78.0 | 5.0 U | 10.0 | 5.0 U | 5.0 U | 16.8 | 8.37 | 15.7 | 8.8 |
| Propane | 6.0 U | 6.0 U | 6.0 U | 6.0 U | 6.0 U | 6.0 U | 6.0 U | 6.0 U | 6.0 U | 6.0 U | 6.0 U | 6.0 U | 6.0 U |
| Acetylene | 10.0 U | 10.0 U | -- | 10.0 U | 10.0 U | -- | 10.0 U | 10.0 U | -- | 10.0 U | 10.0 U | -- | 10.0 U |
| OTHER GASES (GC) | µg/L | µg/L | µg/L | µg/L | µg/L | µg/L | µg/L | µg/L | µg/L | µg/L | µg/L | µg/L | µg/L |
| Hydrogen | -- | -- | 0.0084 U | -- | -- | 0.308 | 0.0084 U | -- | 0.0084 U | -- | -- | 0.0084 U | -- |
| METALS (DISSOLVED) | µg/L | µg/L | µg/L | µg/L | µg/L | µg/L | µg/L | µg/L | µg/L | µg/L | µg/L | µg/L | µg/L |
| Iron | 2490 | -- | 3750 | 1810 | -- | 7470 | 3490 | -- | 1540 | 1460 | -- | 1950 | 1730 |
| Manganese | 618 | -- | 908 | 403 | -- | 954 | 970 | -- | 863 | 733 | -- | 596 | 548 |
| GROUNDWATER CHEMISTRY | mg/L | mg/L | mg/L | mg/L | mg/L | mg/L | mg/L | mg/L | mg/L | mg/L | mg/L | mg/L | mg/L |
| Total Organic Carbon (TOC) | 20.2 | -- | 14.1 | 17.7 | -- | 13.6 | 18.1 | -- | 12.5 | 18.8 | -- | 4.24 | 13.8 |
| ANIONS | mg/L | mg/L | mg/L | mg/L | mg/L | mg/L | mg/L | mg/L | mg/L | mg/L | mg/L | mg/L | mg/L |
| Chloride | 856 D | 745 D | 774 D | 635 D | 352 D | 625 D | 728 D | 669 D | 469 D | 368 D | 337 D | 1090 D | 1210 D |
| Nitrite as N | 4.0 U | 0.2 U | 0.2 U | 4.0 U | 0.2 U | 0.2 U | 4.0 U | 0.2 U | 0.2 U | 4.0 U | 0.2 U | 0.2 U | 4.0 U |
| Sulfate as SO ₄ | 130 D | 136 D | 163 D | 200 D | 108 D | 124 D | 219 D | 208 D | 154 D | 170 D | 150 D | 185 D | 197 D |
| Bromide | 3.72 JD | 3.60 | 3.68 | 4.05 D | 1.50 | 3.04 | 4.39 D | 2.49 | 1.69 | 2.60 JD | 1.49 | 7.36 | 11.7 D |
| Nitrate as N | 4.0 U | 0.2 U | 0.2 U | 4.0 U | 0.2 U | 0.2 U | 4.0 U | 0.2 U | 0.2 U | 4.0 U | 0.2 U | 0.2 U | 4.0 U |
| O-Phosphate as P | 4.0 U | 0.2 U | 0.2 U | 4.43 D | 0.2 U | 0.2 U | 3.28 JD | 0.2 U | 1.68 | 4.63 | 2.42 | 0.2 U | 4.0 U |
| VOLATILE FATTY ACIDS | mg/L | mg/L | mg/L | mg/L | mg/L | mg/L | mg/L | mg/L | mg/L | mg/L | mg/L | mg/L | mg/L |
| Lactic Acid | -- | -- | 1.0 U | -- | -- | 1.0 U | -- | -- | 1.0 U | -- | -- | -- | -- |
| Acetic Acid | -- | -- | 1.0 U | -- | -- | 1.0 U | -- | -- | 1.0 U | -- | -- | -- | -- |
| Propionic Acid | -- | -- | 1.0 U | -- | -- | 1.0 U | -- | -- | 1.0 U | -- | -- | -- | -- |
| Formic Acid | -- | -- | 1.0 U | -- | -- | 1.0 U | -- | -- | 1.0 U | -- | -- | -- | -- |
| Butyric Acid | -- | -- | 1.0 U | -- | -- | 1.0 U | -- | -- | 1.0 U | -- | -- | -- | -- |
| Pyruvic Acid | -- | -- | 1.0 U | -- | -- | 1.0 U | -- | -- | 1.0 U | -- | -- | -- | -- |
| Valeric Acid | -- | -- | 1.0 U | -- | -- | 1.0 U | -- | -- | 1.0 U | -- | -- | -- | -- |
| FIELD PARAMETERS | | | | | | | | | | | | | |
| pH (SU) | 7.25 | 7.07 | 7.23 | 7.36 | 6.71 | 7.11 | 7.25 | 7.11 | 7.32 | 7.40 | 7.27 | 7.08 | 7.16 |
| Temperature (°C) | 21.35 | 21.65 | 19.88 | 21.45 | 21.06 | 19.33 | 21.05 | 23.87 | 19.33 | 21.09 | 23.47 | 18.78 | 20.23 |
| Dissolved Oxygen (DO; mg/L) | 0.64 | 0.86 | 0.21 | 0.58 | 0.88 | 0.50 | 1.22 | 0.76 | 0.38 | 0.72 | 0.70 | 2.58 | 2.32 |
| Redox Potential (ORP; mV) | -145.7 | -21.1 | -145.4 | -154.4 | -39.9 | -124.1 | -141.3 | -23.2 | -134.4 | -139.5 | -32.3 | -105.3 | -157.5 |
| Conductivity (µS/cm) | 4679 | -- | 4637 | 3144 | -- | 4040 | 4016 | -- | 3162 | 2773 | -- | 5368 | 6131 |
| Turbidity (NTU) | 35.30 | 58.72 | 162.25 | 31.24 | 122.74 | 191.35 | 28.87 | 22.24 | 153.42 | 23.00 | 10.22 | 2.57 | 13.66 |

Notes:

BOLD value indicates the compound was detected above the reporting limit.

U indicates the compound was not detected at the indicated concentration.

J indicates the presence of a compound that meets the identification criteria. The result is less than the quantitation limit but greater than zero, and is given an approximate value.

-- indicates analysis was not performed

D indicates the sample was diluted prior to analysis

APPENDIX D.3: GROUNDWATER ANALYTICAL DATA SUMMARY (OTHER ANALYTICAL AND FIELD PARAMETERS)

| Sample ID | PMLS1-2 | PMLS1-2 | PMLS1-3 | PMLS1-3 | PMLS1-4 | PMLS1-4 | PMLS1-5 | PMLS1-6 | PMLS1-7 | PMLS2-1 | PMLS2-1 | PMLS2-1 | PMLS2-2 | PMLS2-2 | |
|-----------------------------|----------------|---------------|---------------|---------------|-----------------|---------------|---------------|---------------|----------------|-----------------|---------------|---------------|---------------|---------------|---------------|
| Sampling Date | 3/9/2015 | 12/1/2015 | 3/9/2015 | 12/1/2015 | 3/9/2015 | 12/1/2015 | 3/9/2015 | 3/9/2015 | 3/9/2015 | 3/9/2015 | 12/1/2015 | 8/1/2016 | 3/9/2015 | 12/1/2015 | |
| REDUCED GASES (GC) | µg/L | µg/L | µg/L | µg/L | µg/L | µg/L | µg/L | µg/L | µg/L | µg/L | µg/L | µg/L | µg/L | µg/L | |
| Methane | 10800 D | 72.7 | 424 | 188 | 639 | 50.2 | 349 | 115 | 1220 | 3470 D | 403.0 | 971 | 4840 D | 44.4 | |
| Ethane | 47.0 | 4.0 U | 4.46 | 1.9 J | 8.73 | 4.0 U | 5.27 | 1.64 J | 17.7 | 47.7 | 8.1 | 15.2 | 20.5 | 4.0 U | |
| Ethene | 194 | 5.0 U | 5.0 U | 5.0 U | 5.0 U | 5.0 U | 3.7 J | 5.0 U | 5.55 | 393 | 194 | 30.8 | 15.4 | 22.0 | 2.57 J |
| Propane | 6.0 U | 6.0 U | 6.0 U | 6.0 U | 6.0 U | 6.0 U | 6.0 U | 6.0 U | 6.0 U | 6.0 U | 6.0 U | 6.0 U | 6.0 U | 6.0 U | 6.0 U |
| Acetylene | -- | 10.0 U | -- | 10.0 U | -- | 10.0 U | -- | -- | -- | -- | 10.0 U | 10.0 U | -- | 10.0 U | |
| OTHER GASES (GC) | µg/L | µg/L | µg/L | µg/L | µg/L | µg/L | µg/L | µg/L | µg/L | µg/L | µg/L | µg/L | µg/L | µg/L | |
| Hydrogen | 0.0084 U | -- | 0.0084 U | -- | 0.0031 J | -- | 0.0084 U | 0.0084 U | 0.0084 U | 0.0022 J | -- | -- | 0.0084 U | -- | |
| METALS (DISSOLVED) | µg/L | µg/L | µg/L | µg/L | µg/L | µg/L | µg/L | µg/L | µg/L | µg/L | µg/L | µg/L | µg/L | µg/L | |
| Iron | 1200 | 898 | 3570 | 2850 | 2160 | 1860 | 70.0 U | 70.0 U | 16800 | 963 | 969 | -- | 369 | 525 | |
| Manganese | 1110 | 864 | 983 | 666 | 1130 | 1020 | 459 | 2240 | 9220 | 798 | 716 | -- | 330 | 665 | |
| GROUNDWATER CHEMISTRY | mg/L | mg/L | mg/L | mg/L | mg/L | mg/L | mg/L | mg/L | mg/L | mg/L | mg/L | mg/L | mg/L | mg/L | |
| Total Organic Carbon (TOC) | 4.02 | 16.8 | 2.96 | 14.0 | 1.73 J | 12.7 | 0.89 J | 2.16 | 24.4 | 3.88 | 21.0 | -- | 2.0 U | 16.5 | |
| ANIONS | mg/L | mg/L | mg/L | mg/L | mg/L | mg/L | mg/L | mg/L | mg/L | mg/L | mg/L | mg/L | mg/L | mg/L | |
| Chloride | 758 D | 598 D | 1060 D | 956 D | 1180 D | 1310 D | 2890 D | 8810 D | 11800 D | 1340 D | 1370 D | 1030 D | 448 D | 532 D | |
| Nitrite as N | 0.2 U | 4.0 U | 0.2 U | 4.0 U | 0.2 U | 4.0 U | 0.2 U | 0.2 U | 0.2 U | 0.2 U | 4.0 U | 0.2 U | 0.2 U | 4.0 U | |
| Sulfate as SO ₄ | 112 D | 206 D | 48.0 D | 172 D | 57.0 D | 64.9 D | 460 D | 1020 D | 1600 D | 219 D | 264 D | 249 D | 70.0 D | 193 D | |
| Bromide | 3.97 | 6.85 D | 4.42 | 4.07 D | 8.72 | 9.70 D | 17 | 31.7 | 32.4 | 7.65 | 6.01 D | 5.73 | 5.40 | 5.57 D | |
| Nitrate as N | 0.2 U | 4.0 U | 0.2 U | 4.0 U | 0.2 U | 4.0 U | 0.51 | 4.7 | 0.2 U | 0.2 U | 4.0 U | 0.2 U | 0.2 U | 4.0 U | |
| O-Phosphate as P | 0.2 U | 4.0 U | 0.2 U | 4.0 U | 0.2 U | 4.0 U | 0.2 U | 0.2 U | 0.2 U | 0.2 U | 4.0 U | 0.2 U | 0.2 U | 4.0 U | |
| VOLATILE FATTY ACIDS | mg/L | mg/L | mg/L | mg/L | mg/L | mg/L | mg/L | mg/L | mg/L | mg/L | mg/L | mg/L | mg/L | mg/L | |
| Lactic Acid | -- | -- | -- | -- | -- | -- | -- | -- | -- | -- | -- | -- | -- | -- | |
| Acetic Acid | -- | -- | -- | -- | -- | -- | -- | -- | -- | -- | -- | -- | -- | -- | |
| Propionic Acid | -- | -- | -- | -- | -- | -- | -- | -- | -- | -- | -- | -- | -- | -- | |
| Formic Acid | -- | -- | -- | -- | -- | -- | -- | -- | -- | -- | -- | -- | -- | -- | |
| Butyric Acid | -- | -- | -- | -- | -- | -- | -- | -- | -- | -- | -- | -- | -- | -- | |
| Pyruvic Acid | -- | -- | -- | -- | -- | -- | -- | -- | -- | -- | -- | -- | -- | -- | |
| Valeric Acid | -- | -- | -- | -- | -- | -- | -- | -- | -- | -- | -- | -- | -- | -- | |
| FIELD PARAMETERS | | | | | | | | | | | | | | | |
| pH (SU) | 7.17 | 7.52 | 6.96 | 7.20 | 6.94 | 7.01 | 7.09 | 6.64 | 6.52 | 7.02 | 7.12 | 7.07 | 7.22 | 7.40 | |
| Temperature (°C) | 19.21 | 21.05 | 19.15 | 20.76 | 19.18 | 20.02 | 20.03 | 21.47 | 21.20 | 22.19 | 20.93 | 20.33 | 22.08 | 20.81 | |
| Dissolved Oxygen (DO; mg/L) | 1.72 | 3.39 | 2.38 | 3.51 | 1.98 | 3.32 | 2.10 | 1.61 | 2.08 | 1.89 | 3.18 | 2.42 | 2.24 | 3.87 | |
| Redox Potential (ORP; mV) | -77.5 | -121.7 | -78.9 | -116.8 | -106.5 | -165.7 | -60.3 | -88.0 | -144.1 | -142.8 | -159.7 | -20.4 | -98.4 | -129.2 | |
| Conductivity (µS/cm) | 4000 | 3237 | 6226 | 4825 | 6465 | 6913 | 1126 | 25677 | 3057 | 6858 | 6614 | -- | 2767 | 2942 | |
| Turbidity (NTU) | 25.95 | 3.08 | 0.62 | 6.49 | 5.10 | 23.95 | 18.46 | 66.91 | 42.18 | 3.45 | 5.86 | 0.75 | 2.02 | 2.50 | |

Notes:

BOLD value indicates the compound was detected above the reporting limit.

U indicates the compound was not detected at the indicated concentration.

J indicates the presence of a compound that meets the identification criteria. The result is less than the quantitation limit but greater than zero, and is given an approximate value.

-- indicates analysis was not performed

D indicates the sample was diluted prior to analysis

APPENDIX D.3: GROUNDWATER ANALYTICAL DATA SUMMARY (OTHER ANALYTICAL AND FIELD PARAMETERS)

| Sample ID | PMLS2-2 | PMLS2-3 | PMLS2-3 | PMLS2-3 | PMLS2-4 | PMLS2-4 | PMLS2-4 | PMLS2-5 | PMLS2-6 | PMLS2-7 | PMLS3-1 | PMLS3-1 | PMLS3-1 | PMLS3-2 | PMLS3-2 |
|------------------------------|---------------|---------------|----------------|--------------|---------------|----------------|---------------|---------------|----------------|---------------|-----------------|---------------|---------------|---------------|-----------|
| Sampling Date | 8/1/2016 | 3/9/2015 | 12/1/2015 | 8/1/2016 | 3/10/2015 | 12/1/2015 | 3/10/2015 | 3/10/2015 | 3/10/2015 | 3/10/2015 | 3/10/2015 | 12/2/2015 | 8/1/2016 | 3/10/2015 | 12/2/2015 |
| REDUCED GASES (GC) | µg/L | µg/L | µg/L | µg/L | µg/L | µg/L | µg/L | µg/L | µg/L | µg/L | µg/L | µg/L | µg/L | µg/L | µg/L |
| Methane | 177 | 6300 D | 47.6 | 138 | 1230 | 45.6 | 260 | 20.6 | 349 | 285 | 210 | 318 | 211 | 28.5 | |
| Ethane | 1.36 J | 26.5 | 4.0 U | 4.0 U | 6.29 | 4.0 U | 4.0 U | 4.0 U | 3.76 J | 5.05 | 2.23 J | 2.11 J | 2.46 J | 4.0 U | |
| Ethene | 2.62 J | 10.1 | 5.0 U | 5.0 U | 4.63 J | 5.0 U | 5.0 U | 5.0 U | 16.7 | 55.5 | 31.0 | 38.3 | 16.4 | 5.0 U | |
| Propane | 6.0 U | 6.0 U | 6.0 U | 6.0 U | 6.0 U | 6.0 U | 6.0 U | 6.0 U | 6.0 U | 6.0 U | 6.0 U | 6.0 U | 6.0 U | 6.0 U | |
| Acetylene | 10.0 U | -- | 10.0 U | 10.0 U | -- | 10.0 U | -- | -- | -- | -- | 10.0 U | 10.0 U | -- | 10.0 U | |
| OTHER GASES (GC) | µg/L | µg/L | µg/L | µg/L | µg/L | µg/L | µg/L | µg/L | µg/L | µg/L | µg/L | µg/L | µg/L | µg/L | |
| Hydrogen | -- | 0.0084 U | -- | -- | 0.0084 U | -- | 0.0084 U | 0.0084 U | 0.0084 U | 0.0084 U | 0.0024 J | -- | -- | 0.0084 U | -- |
| METALS (DISSOLVED) | µg/L | µg/L | µg/L | µg/L | µg/L | µg/L | µg/L | µg/L | µg/L | µg/L | µg/L | µg/L | µg/L | µg/L | |
| Iron | -- | 2700 | 1560 | -- | 2670 | 1680 | 70.0 U | 70.0 U | 17400 | 1170 | 901 | -- | 1330 | 876 | |
| Manganese | -- | 947 | 506 | -- | 948 | 544 | 471 | 2220 | 8370 | 4017 | 346 | -- | 335 | 314 | |
| GROUNDWATER CHEMISTRY | mg/L | mg/L | mg/L | mg/L | mg/L | mg/L | mg/L | mg/L | mg/L | mg/L | mg/L | mg/L | mg/L | mg/L | |
| Total Organic Carbon (TOC) | -- | 1.58 J | 13.8 | -- | 3.40 | 13.4 | 7.77 | 4.65 | 29.8 | 1.40 J | 13.60 | -- | 2.0 U | 15.5 | |
| ANIONS | mg/L | mg/L | mg/L | mg/L | mg/L | mg/L | mg/L | mg/L | mg/L | mg/L | mg/L | mg/L | mg/L | mg/L | |
| Chloride | 383 D | 1020 D | 869 D | 607 D | 1090 D | 883 D | 3390 D | 9580 D | 11900 D | 1280 D | 1380 D | 1120 D | 561 D | 485 D | |
| Nitrite as N | 0.2 U | 0.2 U | 4.0 U | 0.2 U | 0.2 U | 4.0 U | 0.2 U | 0.2 U | 0.2 U | 0.2 U | 4.0 U | 0.2 U | 0.2 U | 4.0 U | |
| Sulfate as SO ₄ | 140 D | 84.9 D | 182 D | 173 D | 96.2 D | 178 D | 392 D | 1170 D | 1610 D | 337 D | 390 D | 364 D | 148 D | 184 D | |
| Bromide | 1.47 | 6.24 | 3.65 JD | 2.78 | 6.0 | 3.83 JD | 12.5 | 23.7 | 30.2 | 5.14 | 8.46 D | 5.29 | 2.45 | 5.67 D | |
| Nitrate as N | 0.2 U | 0.2 U | 4.0 U | 0.2 U | 0.2 U | 4.0 U | 0.7 | 3.2 | 0.2 U | 0.2 U | 4.0 U | 0.2 U | 0.2 U | 4.0 U | |
| O-Phosphate as P | 0.2 U | 0.2 U | 4.0 U | 0.2 U | 0.2 U | 4.0 U | 0.2 U | 0.2 U | 0.2 U | 0.2 U | 4.0 U | 0.2 U | 0.2 U | 4.0 U | |
| VOLATILE FATTY ACIDS | mg/L | mg/L | mg/L | mg/L | mg/L | mg/L | mg/L | mg/L | mg/L | mg/L | mg/L | mg/L | mg/L | mg/L | |
| Lactic Acid | -- | -- | -- | -- | -- | -- | -- | -- | -- | -- | -- | -- | -- | -- | |
| Acetic Acid | -- | -- | -- | -- | -- | -- | -- | -- | -- | -- | -- | -- | -- | -- | |
| Propionic Acid | -- | -- | -- | -- | -- | -- | -- | -- | -- | -- | -- | -- | -- | -- | |
| Formic Acid | -- | -- | -- | -- | -- | -- | -- | -- | -- | -- | -- | -- | -- | -- | |
| Butyric Acid | -- | -- | -- | -- | -- | -- | -- | -- | -- | -- | -- | -- | -- | -- | |
| Pyruvic Acid | -- | -- | -- | -- | -- | -- | -- | -- | -- | -- | -- | -- | -- | -- | |
| Valeric Acid | -- | -- | -- | -- | -- | -- | -- | -- | -- | -- | -- | -- | -- | -- | |
| FIELD PARAMETERS | | | | | | | | | | | | | | | |
| pH (SU) | 7.20 | 7.04 | 7.09 | 6.94 | 7.00 | 7.18 | 6.96 | 6.70 | 6.53 | 7.04 | 7.31 | 7.40 | 7.25 | 7.96 | |
| Temperature (°C) | 20.75 | 22.10 | 20.06 | 20.24 | 17.12 | 20.52 | 17.71 | 17.75 | 18.03 | 19.22 | 18.87 | 22.13 | 19.67 | 19.55 | |
| Dissolved Oxygen (DO; mg/L) | 2.28 | 2.20 | 3.52 | 2.85 | 2.31 | 3.18 | 2.51 | 2.10 | 2.07 | 2.02 | 3.14 | 2.99 | 2.31 | 3.42 | |
| Redox Potential (ORP; mV) | -28.5 | -78.5 | -115.7 | -13.6 | -66.8 | -99.5 | -18.3 | -45.2 | -131.9 | -70.5 | -81.0 | -39.6 | -80.5 | -86.9 | |
| Conductivity (µS/cm) | -- | 6122 | 4555 | -- | 5610 | 4622 | 11389 | 23564 | 26431 | 49176 | 5661 | -- | 32245 | 30.9 | |
| Turbidity (NTU) | 3.39 | 1.04 | 3.27 | 0.21 | 1.52 | 1.49 | 27.78 | 61.53 | 3.21 | 13.47 | 11.88 | 4.53 | 1.21 | 4.39 | |

Notes:

BOLD value indicates the compound was detected above the reporting limit.

U indicates the compound was not detected at the indicated concentration.

J indicates the presence of a compound that meets the identification criteria. The result is less than the quantitation limit but greater than zero, and is given an approximate value.

-- indicates analysis was not performed

D indicates the sample was diluted prior to analysis

APPENDIX D.3: GROUNDWATER ANALYTICAL DATA SUMMARY (OTHER ANALYTICAL AND FIELD PARAMETERS)

| Sample ID | PMLS3-2 | PMLS3-3 | PMLS3-3 | PMLS3-3 | PMLS3-4 | PMLS3-4 | PMLS3-5 | PMLS3-5 | PMLS3-5 | PMLS3-6 | PMLS3-7 | PMLS4-1 | PMLS4-1 | PMLS4-1 |
|-----------------------------|--------------|---------------|---------------|---------------|---------------|---------------|---------------|---------------|---------------|----------------|----------------|---------------|--------------|---------------|
| Sampling Date | 8/1/2016 | 3/10/2015 | 12/2/2015 | 8/1/2016 | 3/10/2015 | 12/2/2015 | 3/10/2015 | 12/2/2015 | 3/10/2015 | 12/2/2015 | 3/10/2015 | 3/11/2015 | 12/2/2015 | 8/1/2016 |
| REDUCED GASES (GC) | µg/L | µg/L | µg/L | µg/L | µg/L | µg/L | µg/L | µg/L | µg/L | µg/L | µg/L | µg/L | µg/L | µg/L |
| Methane | 97.1 | 15.1 | 26.4 | 118 | 317 | 165 | 78.5 | 109 | 24.6 | 881 | 1180 | 154 | 382 | |
| Ethane | 4.0 U | 4.0 U | 4.0 U | 4.0 U | 1.87 J | 4.0 U | 4.0 U | 4.0 U | 4.0 U | 4.0 U | 14.2 | 8.24 | 4.0 U | 2.11 J |
| Ethene | 8.48 | 5.0 U | 5.0 U | 3.19 J | 5.0 U | 5.0 U | 5.0 U | 5.0 U | 5.0 U | 5.0 U | 67.6 | 121 | 30.0 | 81.4 |
| Propane | 6.0 U | 6.0 U | 6.0 U | 6.0 U | 6.0 U | 6.0 U | 6.0 U | 6.0 U | 6.0 U | 6.0 U | 6.0 U | 6.0 U | 6.0 U | 6.0 U |
| Acetylene | 10.0 U | -- | 10.0 U | 10.0 U | -- | 10.0 U | -- | 10.0 U | -- | -- | -- | 10.0 U | 10.0 U | |
| OTHER GASES (GC) | µg/L | µg/L | µg/L | µg/L | µg/L | µg/L | µg/L | µg/L | µg/L | µg/L | µg/L | µg/L | µg/L | µg/L |
| Hydrogen | -- | 0.0084 U | -- | -- | 0.0084 U | -- | 0.0084 U | -- | 0.0084 U | 0.0084 U | 0.0084 U | 0.0084 U | -- | -- |
| METALS (DISSOLVED) | µg/L | µg/L | µg/L | µg/L | µg/L | µg/L | µg/L | µg/L | µg/L | µg/L | µg/L | µg/L | µg/L | µg/L |
| Iron | -- | 677 | 353 | -- | 3550 | 3970 | 492 | 1080 | 70.0 U | 12400 | 1000 | 826 | -- | |
| Manganese | -- | 509 | 347 | -- | 1000 | 956 | 668 | 649 | 1870 | 6230 | 379 | 292 | -- | |
| GROUNDWATER CHEMISTRY | mg/L | mg/L | mg/L | mg/L | mg/L | mg/L | mg/L | mg/L | mg/L | mg/L | mg/L | mg/L | mg/L | mg/L |
| Total Organic Carbon (TOC) | -- | 1.36 J | 12.1 | -- | 25.6 | 15.1 | 2.0 U | 12.5 | 1.10 J | 16.4 | 18.9 | 18.5 | -- | |
| ANIONS | mg/L | mg/L | mg/L | mg/L | mg/L | mg/L | mg/L | mg/L | mg/L | mg/L | mg/L | mg/L | mg/L | mg/L |
| Chloride | 408 D | 905 D | 876 D | 623 D | 2060 D | 1570 D | 2830 D | 2110 D | 8990 D | 12000 D | 1422 ED | 1340 D | 723 D | |
| Nitrite as N | 0.2 U | 0.2 U | 4.0 U | 0.2 U | 0.2 U | 4.0 U | 0.2 U | 4.0 U | 0.2 U | 4.0 U | 0.2 U | 4.0 U | 4.0 U | 0.2 U |
| Sulfate as SO ₄ | 150 D | 140 D | 256 D | 209 D | 250 D | 149 D | 375 D | 267 D | 1100 D | 1640 D | 409 D | 432 D | 223 D | |
| Bromide | 2.00 | 8.37 | 3.45 D | 2.54 | 9.54 | 7.81 D | 11.1 | 10.4 D | 23.4 | 22.6 | 3.42 JD | 4.77 D | 3.14 | |
| Nitrate as N | 0.2 U | 0.2 U | 4.0 U | 0.2 U | 0.2 U | 4.0 U | 0.2 U | 4.0 U | 0.2 U | 4.0 U | 0.2 U | 4.0 U | 4.0 U | 0.2 U |
| O-Phosphate as P | 0.2 U | 0.2 U | 4.0 U | 0.2 U | 0.2 U | 4.0 U | 0.2 U | 4.0 U | 0.2 U | 4.0 U | 0.2 U | 4.0 U | 4.0 U | 0.2 U |
| VOLATILE FATTY ACIDS | mg/L | mg/L | mg/L | mg/L | mg/L | mg/L | mg/L | mg/L | mg/L | mg/L | mg/L | mg/L | mg/L | mg/L |
| Lactic Acid | -- | -- | -- | -- | -- | -- | -- | -- | -- | -- | -- | -- | -- | -- |
| Acetic Acid | -- | -- | -- | -- | -- | -- | -- | -- | -- | -- | -- | -- | -- | -- |
| Propionic Acid | -- | -- | -- | -- | -- | -- | -- | -- | -- | -- | -- | -- | -- | -- |
| Formic Acid | -- | -- | -- | -- | -- | -- | -- | -- | -- | -- | -- | -- | -- | -- |
| Butyric Acid | -- | -- | -- | -- | -- | -- | -- | -- | -- | -- | -- | -- | -- | -- |
| Pyruvic Acid | -- | -- | -- | -- | -- | -- | -- | -- | -- | -- | -- | -- | -- | -- |
| Valeric Acid | -- | -- | -- | -- | -- | -- | -- | -- | -- | -- | -- | -- | -- | -- |
| FIELD PARAMETERS | | | | | | | | | | | | | | |
| pH (SU) | 7.30 | 7.07 | 7.30 | 7.20 | 7.03 | 7.02 | 6.98 | 7.17 | 6.64 | 6.65 | 7.17 | 7.25 | 6.92 | |
| Temperature (°C) | 21.59 | 20.19 | 19.51 | 22.68 | 20.73 | 19.18 | 20.85 | 18.72 | 21.55 | 20.64 | 17.24 | 19.02 | 24.19 | |
| Dissolved Oxygen (DO; mg/L) | 2.55 | 2.63 | 2.12 | 3.12 | 2.44 | 2.95 | 1.85 | 2.62 | 1.97 | 1.51 | 2.93 | 3.10 | 2.65 | |
| Redox Potential (ORP; mV) | -33.7 | -81.6 | -124.0 | -28.8 | -88.7 | -99.8 | -123.5 | -120.5 | -116.8 | -168.2 | -53.1 | -58.8 | -11.9 | |
| Conductivity (µS/cm) | -- | 50700 | 4335 | -- | 79447 | 7579 | 10273 | 10155 | 23658 | 29654 | 6645 | 5908 | -- | |
| Turbidity (NTU) | 1.72 | 3.29 | 767.6 | 170.54 | 92.99 | 5.63 | 63.75 | 93.94 | 109.20 | 84.22 | 11.59 | 4.00 | 16.93 | |

Notes:

BOLD value indicates the compound was detected above the reporting limit.

U indicates the compound was not detected at the indicated concentration.

J indicates the presence of a compound that meets the identification criteria. The result is less than the quantitation limit but greater than zero, and is given an approximate value.

-- indicates analysis was not performed

D indicates the sample was diluted prior to analysis

APPENDIX D.3: GROUNDWATER ANALYTICAL DATA SUMMARY (OTHER ANALYTICAL AND FIELD PARAMETERS)

| Sample ID | PMLS4-2 | PMLS4-2 | PMLS4-2 | PMLS4-3 | PMLS4-3 | PMLS4-3 | PMLS4-4 | PMLS4-4 | PMLS4-5 | PMLS4-5 | PMLS4-6 | PMLS4-7 | PMLS5-1 |
|-----------------------------|---------------|---------------|--------------|---------------|---------------|--------------|---------------|---------------|----------------|---------------|----------------|----------------|----------------|
| Sampling Date | 3/10/2015 | 12/2/2015 | 8/1/2016 | 3/10/2015 | 12/2/2015 | 8/1/2016 | 3/10/2015 | 12/2/2015 | 3/11/2015 | 12/2/2015 | 3/11/2015 | 3/11/2015 | 3/12/2015 |
| REDUCED GASES (GC) | µg/L | µg/L | µg/L | µg/L | µg/L | µg/L | µg/L | µg/L | µg/L | µg/L | µg/L | µg/L | µg/L |
| Methane | 474 | 9.41 | 27.2 | 330 | 15.8 | 98.7 | 1340 | 110 | 314 | 56.5 | 750 | 729 | 185 |
| Ethane | 3.25 J | 4.0 U | 4.0 U | 3.70 J | 4.0 U | 4.0 U | 4.69 J | 1.79 J | 6.37 | 4.0 U | 6.38 | 25.2 | 1.65 |
| Ethene | 28.2 | 3.54 J | 5.19 | 2.04 J | 2.53 J | 2.28 | 5.0 U | 5.0 U | 4.73 | 5.0 U | 27.0 | 70.2 | 54.4 |
| Propane | 6.0 U | 6.0 U | 6.0 U | 6.0 U | 6.0 U | 6.0 U | 6.0 U | 6.0 U | 6.0 U | 6.0 U | 6.0 U | 6.0 U | 6.0 U |
| Acetylene | -- | 10.0 U | 10.0 U | -- | 10.0 U | 10.0 U | -- | 10.0 U | -- | 10.0 U | -- | -- | -- |
| OTHER GASES (GC) | µg/L | µg/L | µg/L | µg/L | µg/L | µg/L | µg/L | µg/L | µg/L | µg/L | µg/L | µg/L | µg/L |
| Hydrogen | 0.0084 U | -- | -- | 0.0084 U | -- | -- | 0.0084 U | -- | 0.0084 U | -- | 0.0084 U | 0.0084 U | 0.0084 U |
| METALS (DISSOLVED) | µg/L | µg/L | µg/L | µg/L | µg/L | µg/L | µg/L | µg/L | µg/L | µg/L | µg/L | µg/L | µg/L |
| Iron | 830 | 603 | -- | 1420 | 1270 | -- | 1080 | 1320 | 482 | 662 | 2130 | 14900 | 2120 |
| Manganese | 273 | 265 | -- | 1060 | 863 | -- | 576 | 487 | 506 | 493 | 2010 | 7170 | 586 |
| GROUNDWATER CHEMISTRY | mg/L | mg/L | mg/L | mg/L | mg/L | mg/L | mg/L | mg/L | mg/L | mg/L | mg/L | mg/L | mg/L |
| Total Organic Carbon (TOC) | 1.52 J | 18.1 | -- | 1.60 J | 13.2 | -- | 1.50 J | 12.6 | 13.8 | 10.9 | 21.7 | 109 | 17.6 |
| ANIONS | mg/L | mg/L | mg/L | mg/L | mg/L | mg/L | mg/L | mg/L | mg/L | mg/L | mg/L | mg/L | mg/L |
| Chloride | 535 D | 413 D | 319 D | 901 D | 903 D | 597 D | 1840 D | 1520 D | 2544 ED | 2720 D | 6080 ED | 9310 ED | 1860 ED |
| Nitrite as N | 0.2 U | 4.0 U | 0.2 U | 0.2 U | 4.0 U | 0.2 U | 0.2 U | 4.0 U | 4.0 U | 4.0 U | 4.0 U | 4.0 U | 4.0 U |
| Sulfate as SO ₄ | 171 D | 173 D | 139 D | 163 D | 266 D | 201 D | 233 D | 157 D | 294 D | 338 D | 732 D | 1380 ED | 390 D |
| Bromide | 2.22 | 4.0 U | 1.42 | 4.37 | 3.80 D | 2.58 | 9.26 | 9.97 D | 8.29 D | 12.2 D | 15.7 D | 25.2 D | 3.11 JD |
| Nitrate as N | 0.2 U | 4.0 U | 0.2 U | 0.2 U | 4.0 U | 0.2 U | 0.2 U | 4.0 U | 4.0 U | 4.0 U | 4.0 U | 4.0 U | 4.0 U |
| O-Phosphate as P | 0.2 U | 4.0 U | 0.2 U | 0.2 U | 4.0 U | 0.2 U | 0.2 U | 4.0 U | 4.0 U | 4.0 U | 4.0 U | 4.0 U | 4.0 U |
| VOLATILE FATTY ACIDS | mg/L | mg/L | mg/L | mg/L | mg/L | mg/L | mg/L | mg/L | mg/L | mg/L | mg/L | mg/L | mg/L |
| Lactic Acid | -- | -- | -- | -- | -- | -- | -- | -- | -- | -- | -- | -- | -- |
| Acetic Acid | -- | -- | -- | -- | -- | -- | -- | -- | -- | -- | -- | -- | -- |
| Propionic Acid | -- | -- | -- | -- | -- | -- | -- | -- | -- | -- | -- | -- | -- |
| Formic Acid | -- | -- | -- | -- | -- | -- | -- | -- | -- | -- | -- | -- | -- |
| Butyric Acid | -- | -- | -- | -- | -- | -- | -- | -- | -- | -- | -- | -- | -- |
| Pyruvic Acid | -- | -- | -- | -- | -- | -- | -- | -- | -- | -- | -- | -- | -- |
| Valeric Acid | -- | -- | -- | -- | -- | -- | -- | -- | -- | -- | -- | -- | -- |
| FIELD PARAMETERS | | | | | | | | | | | | | |
| pH (SU) | 7.38 | 7.46 | 7.33 | 7.16 | 7.30 | 7.16 | 7.02 | 7.03 | 6.82 | 6.53 | 6.34 | 6.61 | 7.26 |
| Temperature (°C) | 19.29 | 20.49 | 24.29 | 18.91 | 20.83 | 23.51 | 19.21 | 20.34 | 19.95 | 19.74 | 21.22 | 22.23 | 20.33 |
| Dissolved Oxygen (DO; mg/L) | 2.65 | 2.43 | 1.97 | 2.34 | 2.68 | 2.28 | 2.05 | 2.88 | 2.51 | 2.86 | 2.43 | 1.73 | 2.60 |
| Redox Potential (ORP; mV) | -87.9 | -99.7 | -35.8 | -91.4 | -105.7 | -25.8 | -62.4 | -106.9 | -69.8 | -106.3 | 44.7 | -108.1 | -104.5 |
| Conductivity (µS/cm) | 3187 | 2858 | -- | 4733 | 4456 | -- | 6427 | 5644 | 7179 | 3003 | 9305 | 30907 | 6729 |
| Turbidity (NTU) | 3.69 | 9.68 | 6.51 | 0.95 | 6.54 | 9.51 | 9.28 | 1.34 | 69.93 | 36.05 | 86.26 | 129.44 | 26.83 |

Notes:

BOLD value indicates the compound was detected above the reporting limit.

U indicates the compound was not detected at the indicated concentration.

J indicates the presence of a compound that meets the identification criteria. The result is less than the quantitation limit but greater than zero, and is given an approximate value.

-- indicates analysis was not performed

D indicates the sample was diluted prior to analysis

APPENDIX D.3: GROUNDWATER ANALYTICAL DATA SUMMARY (OTHER ANALYTICAL AND FIELD PARAMETERS)

| Sample ID | PMLS5-1 | PMLS5-2 | PMLS5-2 | PMLS5-3 | PMLS5-3 | PMLS5-4 | PMLS5-4 | PMLS5-5 | PMLS5-6 | PMLS5-7 | PMLS6-1 | PMLS6-2 |
|------------------------------|---------------|----------------|---------------|---------------|---------------|----------------|---------------|----------------|----------------|----------------|----------------|-----------------|
| Sampling Date | 12/2/2015 | 3/12/2015 | 12/2/2015 | 3/12/2015 | 12/2/2015 | 3/12/2015 | 12/2/2015 | 3/12/2015 | 3/12/2015 | 3/12/2015 | 3/11/2015 | 3/11/2015 |
| REDUCED GASES (GC) | µg/L | µg/L | µg/L | µg/L | µg/L | µg/L | µg/L | µg/L | µg/L | µg/L | µg/L | µg/L |
| Methane | 137 | 10.7 | 7.11 | 153 | 21.1 | 670 | 119 | 76.3 | 129 | 613 | 525 | 81.7 |
| Ethane | 4.0 U | 4.0 U | 4.0 U | 4.0 U | 4.0 U | 4.0 U | 4.0 U | 4.0 U | 4.0 U | 4.0 U | 4.0 U | 17.7 J |
| Ethene | 5.0 U | 5.0 U | 5.0 U | 5.0 U | 6.57 | 5.0 U | 5.0 U | 2.07 | 2.65 | 2.32 | 170 | 38.1 |
| Propane | 6.0 U | 6.0 U | 6.0 U | 6.0 U | 6.0 U | 6.0 U | 6.0 U | 6.0 U | 6.0 U | 6.0 U | 6.0 U | 6.0 U |
| Acetylene | 10.0 U | -- | 10.0 U | -- | 10.0 U | -- | 10.0 U | -- | -- | -- | -- | -- |
| OTHER GASES (GC) | µg/L | µg/L | µg/L | µg/L | µg/L | µg/L | µg/L | µg/L | µg/L | µg/L | µg/L | µg/L |
| Hydrogen | -- | 0.0084 U | -- | 0.0084 U | -- | 0.0084 U | -- | 0.0084 U | 0.0084 U | 0.0084 U | 0.0084 U | 0.0046 J |
| METALS (DISSOLVED) | µg/L | µg/L | µg/L | µg/L | µg/L | µg/L | µg/L | µg/L | µg/L | µg/L | µg/L | µg/L |
| Iron | 1640 | 192 | 175 | 3210 | 2440 | 1970 | 2850 | 387 | 70.0 U | 15300 | 1620 | 94.0 |
| Manganese | 487 | 389 | 366 | 395 | 466 | 365 | 390 | 523 | 1460 | 5850 | 613 | 82.2 |
| GROUNDWATER CHEMISTRY | mg/L | mg/L | mg/L | mg/L | mg/L | mg/L | mg/L | mg/L | mg/L | mg/L | mg/L | mg/L |
| Total Organic Carbon (TOC) | 18.6 | 12.9 | 18.1 | 13.8 | 12.6 | 14.2 | 11.7 | 13.3 | 12.9 | 26.0 | 55.3 | 20.1 |
| ANIONS | mg/L | mg/L | mg/L | mg/L | mg/L | mg/L | mg/L | mg/L | mg/L | mg/L | mg/L | mg/L |
| Chloride | 1440 D | 424 D | 373 D | 398 D | 922 D | 905 D | 1480 D | 1480 ED | 2370 ED | 6510 ED | 1115 ED | 368 D |
| Nitrite as N | 4.0 U | 4.0 U | 4.0 U | 4.0 U | 4.0 U | 4.0 U | 4.0 U | 4.0 U | 4.0 U | 4.0 U | 4.0 U | 4.0 U |
| Sulfate as SO ₄ | 493 D | 158 D | 171 D | 147 D | 254 D | 184 D | 222 D | 162 D | 295 D | 817 D | 371 D | 134 D |
| Bromide | 5.54 D | 1.00 JD | 2.35 D | 4.0 U | 4.62 D | 2.49 JD | 9.82 D | 6.71 D | 5.67 D | 16.7 D | 3.0 JD | 4.0 U |
| Nitrate as N | 4.0 U | 4.0 U | 4.0 U | 4.0 U | 4.0 U | 4.0 U | 4.0 U | 4.0 U | 4.0 U | 4.0 U | 4.0 U | 4.0 U |
| O-Phosphate as P | 4.0 U | 4.0 U | 4.0 U | 4.0 U | 4.0 U | 4.0 U | 4.0 U | 4.0 U | 4.0 U | 4.0 U | 4.0 U | 4.0 U |
| VOLATILE FATTY ACIDS | mg/L | mg/L | mg/L | mg/L | mg/L | mg/L | mg/L | mg/L | mg/L | mg/L | mg/L | mg/L |
| Lactic Acid | -- | -- | -- | -- | -- | -- | -- | -- | -- | -- | -- | -- |
| Acetic Acid | -- | -- | -- | -- | -- | -- | -- | -- | -- | -- | -- | -- |
| Propionic Acid | -- | -- | -- | -- | -- | -- | -- | -- | -- | -- | -- | -- |
| Formic Acid | -- | -- | -- | -- | -- | -- | -- | -- | -- | -- | -- | -- |
| Butyric Acid | -- | -- | -- | -- | -- | -- | -- | -- | -- | -- | -- | -- |
| Pyruvic Acid | -- | -- | -- | -- | -- | -- | -- | -- | -- | -- | -- | -- |
| Valeric Acid | -- | -- | -- | -- | -- | -- | -- | -- | -- | -- | -- | -- |
| FIELD PARAMETERS | | | | | | | | | | | | |
| pH (SU) | 7.27 | 7.39 | 7.38 | 7.19 | 7.25 | 7.02 | 7.13 | 6.93 | 6.74 | 6.78 | 7.48 | 7.19 |
| Temperature (°C) | 21.81 | 20.40 | 20.04 | 20.48 | 19.63 | 21.28 | 19.29 | 22.11 | 26.27 | 25.29 | 23.15 | 21.92 |
| Dissolved Oxygen (DO; mg/L) | 2.57 | 2.62 | 2.39 | 2.06 | 2.19 | 1.90 | 2.59 | 2.79 | 1.86 | 1.84 | 1.88 | 2.51 |
| Redox Potential (ORP; mV) | -91.9 | -98.5 | -59.7 | -122.8 | -109.6 | -96.8 | -99.2 | -126.2 | -132.8 | -108.8 | -110.1 | -114.3 |
| Conductivity (µS/cm) | 6212 | 2896 | 2746 | 5217 | 4496 | 7227 | 6044 | 788 | 20790 | 26994 | 6726 | 2641 |
| Turbidity (NTU) | 12.13 | 7.71 | 3.34 | 17.11 | 7.23 | 8.33 | 0.87 | 32.45 | 110.88 | 186.69 | 31.28 | 67.80 |

Notes:

BOLD value indicates the compound was detected above the reporting limit.

U indicates the compound was not detected at the indicated concentration.

J indicates the presence of a compound that meets the identification criteria. The result is less than the quantitation limit but greater than zero, and is given an approximate value.

-- indicates analysis was not performed

D indicates the sample was diluted prior to analysis

APPENDIX D.3: GROUNDWATER ANALYTICAL DATA SUMMARY (OTHER ANALYTICAL AND FIELD PARAMETERS)

| Sample ID | PMLS6-3 | PMLS6-4 | PMLS6-5 | PMLS6-6 | PMLS6-7 |
|------------------------------|-----------------|-----------------|-----------------|----------------|----------------|
| Sampling Date | 3/11/2015 | 3/12/2015 | 3/12/2015 | 3/12/2015 | 3/12/2015 |
| REDUCED GASES (GC) | µg/L | µg/L | µg/L | µg/L | µg/L |
| Methane | 45.3 | 13.0 | 31.9 | 32.3 | 194 |
| Ethane | 2.82 J | 4.0 U | 4.0 U | 4.0 U | 4.0 U |
| Ethene | 6.19 | 5.0 U | 5.0 U | 5.0 U | 9.06 |
| Propane | 6.0 U | 6.0 U | 6.0 U | 6.0 U | 6.0 U |
| Acetylene | -- | -- | -- | -- | -- |
| OTHER GASES (GC) | µg/L | µg/L | µg/L | µg/L | µg/L |
| Hydrogen | 0.0031 J | 0.0023 J | 0.0031 J | 0.0084 U | 0.0084 U |
| METALS (DISSOLVED) | µg/L | µg/L | µg/L | µg/L | µg/L |
| Iron | 474 | 70.0 U | 111 | 1870 | 8010 |
| Manganese | 213 | 154 | 280 | 1060 | 4130 |
| GROUNDWATER CHEMISTRY | mg/L | mg/L | mg/L | mg/L | mg/L |
| Total Organic Carbon (TOC) | 15.1 | 9.47 | 9.79 | 15.4 | 62.8 |
| ANIONS | mg/L | mg/L | mg/L | mg/L | mg/L |
| Chloride | 884 D | 1550 ED | 2740 ED | 5360 ED | 9150 ED |
| Nitrite as N | 4.0 U | 4.0 U | 4.0 U | 4.0 U | 4.0 U |
| Sulfate as SO ₄ | 205 D | 244 D | 233 D | 647 D | 1200 ED |
| Bromide | 2.70 JD | 7.50 D | 8.19 D | 14.6 D | 23.8 D |
| Nitrate as N | 4.0 U | 4.0 U | 4.0 U | 4.0 U | 4.0 U |
| O-Phosphate as P | 4.0 U | 4.0 U | 4.0 U | 4.0 U | 4.0 U |
| VOLATILE FATTY ACIDS | mg/L | mg/L | mg/L | mg/L | mg/L |
| Lactic Acid | -- | -- | -- | -- | -- |
| Acetic Acid | -- | -- | -- | -- | -- |
| Propionic Acid | -- | -- | -- | -- | -- |
| Formic Acid | -- | -- | -- | -- | -- |
| Butyric Acid | -- | -- | -- | -- | -- |
| Pyruvic Acid | -- | -- | -- | -- | -- |
| Valeric Acid | -- | -- | -- | -- | -- |
| FIELD PARAMETERS | | | | | |
| pH (SU) | 7.21 | 7.14 | 7.18 | 6.90 | 7.01 |
| Temperature (°C) | 21.86 | 19.11 | 19.93 | 20.65 | 21.92 |
| Dissolved Oxygen (DO; mg/L) | 2.01 | 2.38 | 2.64 | 1.94 | 1.15 |
| Redox Potential (ORP; mV) | 109.7 | -119.7 | -113.1 | -134.3 | -180.6 |
| Conductivity (µS/cm) | 4399 | 6734 | 8435 | 18454 | 27343 |
| Turbidity (NTU) | 16.20 | 17.38 | 3.49 | 81.02 | 176.94 |

Notes:

BOLD value indicates the compound was detected above the reporting limit.

U indicates the compound was not detected at the indicated concentration.

J indicates the presence of a compound that meets the identification criteria. The result is less than the quantitation limit but greater than zero, and is given an approximate value.

-- indicates analysis was not performed

D indicates the sample was diluted prior to analysis

Page Intentionally Left Blank

**APPENDIX E COST ESTIMATE DETAILS: INCREMENTAL COST
ESTIMATE TO "UP-GRADE" TO THE
DEMONSTRATED LONG-TERM PERFORMANCE
ASSESSMENT FOLLOWING BIOAUGMENTATION**

Incremental Cost Estimate to "Up-Grade" to the Demonstrated Long-Term Performance Assessment following Bioaugmentation (3-Year Program) for Base Case Site

| | | | | |
|--|----------|-----------------------------------|----|---------|
| Capital Costs | | \$123,500 | | |
| System Design / Workplan (additional) | \$10,000 | | | |
| Site Planning/Permitting | \$2,500 | | | |
| Well Installation | | 10 MLS wells, 3 long-screen wells | | |
| Mobilization | \$3,000 | | | |
| Oversight Labor | \$15,000 | 50hrs/wk*3 weeks*100/hr | | |
| Subcontract Driller | \$39,000 | 13 wells @ 3,000/well | | |
| Subcontract Surveyor | \$2,500 | | | |
| Materials/Consumables | \$2,000 | | | |
| Utilities/Fuel | \$1,000 | | | |
| Waste Disposal | \$2,500 | | | |
| System Installation | | | | |
| Oversight Labor | \$14,000 | 10hrs/day*7 days*100/hr*2 people | | |
| Equipment/Parts | \$15,000 | | | |
| Materials/Consumables | \$2,000 | | | |
| Utilities/Fuel | \$1,000 | | | |
| System Start-Up Testing | \$4,000 | 10hrs/day*2days*100/hr*2 people | | |
| Data Evaluation/Final Report (additional) | \$10,000 | | | |
| PTT Operation and Maintenance Costs | | \$18,500 | | |
| Labor (System Operation) | \$6,000 | 60hrs/wk*1 week*100/hr | | |
| Labor (Analytical) | \$4,000 | 40hrs/wk*1 week*100/hr | | |
| Labor (Data Management) | \$4,000 | 10hrs/wk*4 weeks*100/hr | | |
| Equipment/Parts | \$1,000 | | | |
| Materials/Consumables | \$2,000 | | | |
| Utilities/Fuel | \$1,000 | | | |
| Waste Disposal | \$500 | | | |
| Groundwater Monitoring Costs (Event 1) | | \$60,425 | | |
| Labor (Sample Crew) | \$12,000 | 10hrs/day*6 days*2 persons*100/hr | | |
| Analytical - VOCs | \$4,505 | \$85 per x | 53 | samples |
| Analytical - Reduced Gases | \$4,505 | \$85 per x | 53 | samples |
| Analytical - Anions | \$3,180 | \$60 per x | 53 | samples |
| Analytical - Dissolved Metals | \$1,325 | \$25 per x | 53 | samples |
| Analytical - VFAs | \$4,505 | \$85 per x | 53 | samples |
| Analytical - Dissolved Hydrogen | \$3,975 | \$75 per x | 53 | samples |
| Analytical - TOC | \$3,180 | \$60 per x | 53 | samples |
| Analytical - Microbial Community | \$4,500 | \$750 per x | 6 | samples |
| Analytical - CSIA | \$3,150 | \$525 per x | 6 | samples |
| Sampling Equipment | \$600 | \$100/day*6 days | | |
| PFM Testing | \$15,000 | | | |
| Groundwater Monitoring Costs (Event 2) | | \$53,250 | | |
| Labor (Sample Crew) | \$10,000 | 10hrs/day*5 days*2 persons*100/hr | | |
| Analytical - VOCs | \$3,825 | \$85 per x | 45 | samples |
| Analytical - Reduced Gases | \$3,825 | \$85 per x | 45 | samples |
| Analytical - Anions | \$2,700 | \$60 per x | 45 | samples |
| Analytical - Dissolved Metals | \$1,125 | \$25 per x | 45 | samples |
| Analytical - VFAs | \$3,825 | \$85 per x | 45 | samples |
| Analytical - Dissolved Hydrogen | \$3,375 | \$75 per x | 45 | samples |
| Analytical - TOC | \$2,700 | \$60 per x | 45 | samples |
| Analytical - Microbial Community | \$3,750 | \$750 per x | 5 | samples |
| Analytical - CSIA | \$2,625 | \$525 per x | 5 | samples |
| Sampling Equipment | \$500 | \$100/day*5 days | | |
| PFM Testing | \$15,000 | | | |

| Groundwater Monitoring Costs (Event 3) | | \$46,550 | | |
|---|----------|-----------------------------------|----|---------|
| Labor (Sample Crew) | \$8,000 | 10hrs/day*4 days*2 persons*100/hr | | |
| Analytical - VOCs | \$3,230 | \$85 per x | 38 | samples |
| Analytical - Reduced Gases | \$3,230 | \$85 per x | 38 | samples |
| Analytical - Anions | \$2,280 | \$60 per x | 38 | samples |
| Analytical - Dissolved Metals | \$950 | \$25 per x | 38 | samples |
| Analytical - VFAs | \$3,230 | \$85 per x | 38 | samples |
| Analytical - Dissolved Hydrogen | \$2,850 | \$75 per x | 38 | samples |
| Analytical - TOC | \$2,280 | \$60 per x | 38 | samples |
| Analytical - Microbial Community | \$3,000 | \$750 per x | 4 | samples |
| Analytical - CSIA | \$2,100 | \$525 per x | 4 | samples |
| Sampling Equipment | \$400 | \$100/day*4 days | | |
| PFM Testing | \$15,000 | | | |
| TOTAL | | \$302,225 | | |