

FINAL REPORT

In Situ Bioremediation of Perchlorate in Vadose Zone Soil Using Gaseous Electron Donors

ESTCP Project ER-0511

NOVEMBER 2009

Patrick Evans
Hua Cai
Karl Hopfensperger
Eva Opitz
Tom Titus
CDM

Rachel Brennan
The Pennsylvania State University

Distribution Statement A: Approved for Public Release,
Distribution is Unlimited



Environmental Security Technology
Certification Program

Table of Contents

Table of Contents	i
List of Tables	v
List of Figures.....	vi
Acronyms	x
Acknowledgements	xiii
Executive Summary	xiv
Background and Technology Description.....	xiv
Performance Objectives and Results.....	xv
Implementation Issues.....	xvii
Costs	xvii
1.0 INTRODUCTION.....	1
1.1 Background	1
1.2 Objective of the Demonstration	2
1.3 Regulatory Drivers	2
2.0 TECHNOLOGY	4
2.1 Technology Description	4
2.2 Technology Development	8
2.3 Advantages and Limitations of the Technology	9
3.0 PERFORMANCE OBJECTIVES.....	10
3.1 Perchlorate Destruction	11
3.2 Nitrate Destruction	12
3.3 Perchlorate Destruction Rate.....	12
3.4 Nitrate Destruction Rate.....	12
3.5 Implementability	13
3.6 Safety.....	13
3.7 Regulatory Acceptance	13
3.8 Ease of Use.....	14
4.0 SITE DESCRIPTION.....	15
4.1 Site Location and History.....	15
4.2 Site Geology/Hydrogeology.....	18

4.2.1	Site Geology.....	18
4.2.2	Site Hydrogeology	18
4.3	Contaminant Distribution.....	22
5.0	TEST DESIGN.....	29
5.1	Conceptual Experimental Design.....	29
5.2	Baseline Characterization.....	30
5.2.1	Drilling, Sample Collection, and Analysis	30
5.2.2	Baseline Characterization Results.....	32
5.3	Phase I – Treatability Study	35
5.3.1	Microcosm Study	35
5.3.2	Air Injection Test	36
5.4	Design and Layout of Technology Components.....	38
5.4.1	Wells and Piezometers	38
5.4.2	Process Equipment.....	41
5.5	Field Testing.....	46
5.5.1	Phase II – Gas Injection Optimization	47
5.5.2	Phase III – Gas Mixture Injection	49
5.5.3	Phase IV – LPG Injection	49
5.5.4	Demobilization.....	50
5.5.5	Investigation-Derived Waste	50
5.6	Sampling Methods.....	50
5.6.1	Gas Sampling and Analysis	50
5.6.2	Soil Sampling and Analysis	54
5.7	Sampling Results.....	57
5.7.1	Tracer Tests.....	57
5.7.2	Optimization Tests	60
5.7.3	Steady State Gas Concentrations	62
5.7.4	Perchlorate and Nitrate Concentrations in Soil.....	68
5.7.5	Trends in Perchlorate and Nitrate Destruction.....	78
5.7.6	Relationship between Contaminant Destruction and Gas Composition	81
5.7.7	Soil Moisture Effects	87
5.7.8	Soil Lithology Effects	92

6.0	PERFORMANCE ASSESSMENT	94
6.1	Perchlorate Destruction	94
6.2	Nitrate Destruction	95
6.3	Perchlorate Destruction Rate.....	95
6.4	Nitrate Destruction Rate.....	96
6.5	Implementability	96
7.0	COST ASSESSMENT	97
7.1	Cost Model	97
7.1.1	Technical Basis	97
7.1.2	Assumptions.....	98
7.1.3	Design Considerations	99
7.1.4	Tasks Included in the Cost Model	99
7.2	Cost Analysis.....	100
7.3	Cost Drivers.....	102
7.3.1	Sensitivity Analysis for Drilling Costs	102
7.3.2	Sensitivity Analysis for Gas Costs.....	103
7.4	Comparison to Alternative Approaches	104
8.0	IMPLEMENTATION ISSUES.....	105
8.1	Regulations and Permits.....	105
8.2	End-User Concerns	105
8.3	Procurement	106
9.0	REFERENCES.....	107

Appendices

Appendix A: Points of Contact

Appendix B: Boring Logs and Well/Piezometer Construction Details

Appendix C: Supplemental Data

Appendix D: Treatability Test Report

Appendix E: Quality Assurance and Quality Control

Appendix F: GEDIT General Engineering Guidance

List of Tables

Table 1 – Chronological Summary of Technology Development	8
Table 2 – Technical Limitations and Risks.....	9
Table 3 – Performance Objectives	10
Table 4 – Well and Piezometer Distances	39
Table 5 – Summary of Well Construction Details.....	40
Table 6 – Gas Supply Equipment	46
Table 7 – Phase II Tracer Test Conditions.....	47
Table 8 – Phase II Optimization Tests	49
Table 9 - Total Number and Types of Samples Collected.....	51
Table 10 - Analytical Methods for Sample Analysis.....	52
Table 11 – Rotameter Correction Factors	54
Table 12 – List of Soil Samples Collected.....	55
Table 13 – Tracer Test Operating Conditions.....	58
Table 14 – Distribution of Gas Volumes Required to Attain 50 Percent of Injected Hydrogen Concentration in Piezometers	59
Table 15 – Optimization Test Conditions	60
Table 16 – Optimization Test Minimum Oxygen Concentrations.....	61
Table 17 – Design Basis for Each Scenario.....	98
Table 18 – Project Implementation Costs for GEDIT at IRCTS Site under Different Scenarios	101
Table 19 – Percentages of Total Costs Contributed by Major Cost Drivers	102

List of Figures

Figure 1 – Comparison of Bioventing and Gaseous Electron Donor Injection Technology	4
Figure 2 – Example Gas Injection GEDIT Process and Instrumentation Diagram	6
Figure 3 – Example SVE GEDIT Process and Instrumentation Diagram	7
Figure 4 – Vicinity Map, Inactive Rancho Cordova Test Site.....	16
Figure 5 – IRCTS Site Map	17
Figure 6 – Cross-Section Locations.....	19
Figure 7 – Generalized Lithologic Cross-Sections A1-A1’ and A2-A2’	20
Figure 8 – Generalized Lithologic Cross-Section A2-A1’	21
Figure 9 – Maximum Perchlorate Concentrations in Soil 0’ to 20’ Below Ground Surface.....	23
Figure 10 – Maximum Perchlorate Concentrations in Soil 21’ to 70’ Below Ground Surface....	24
Figure 11 – Maximum Perchlorate Concentrations in Soil 71’ to 140’ Below Ground Surface..	25
Figure 12 – Perchlorate in Soil Depth Profile Locations	26
Figure 13 – Perchlorate in Soil Depth Profile B-B’	27
Figure 14 – Perchlorate in Soil Depth Profile E-E’	28
Figure 15 – Demonstration Phases	29
Figure 16 – Locations of Soil Borings/Pilot Test Wells.....	31
Figure 17 – CDM-INJ1 Grain Size Distribution.....	32
Figure 18 – CDM-P1 Grain Size Distribution	32
Figure 19 – Generalized Lithologic Cross Section.....	33
Figure 20 – CDM-INJ1 Contaminant and Moisture Distribution.....	34
Figure 21 – CDM-P1 Contaminant and Moisture Distribution	34
Figure 22 – Microcosm Study Results at the High Moisture Condition.....	36
Figure 23 – Effect of Air Injection Flow on Pressure at 120 ft amsl.....	37
Figure 24 – Relationship between Distance from Injection Well INJ1 and Piezometer Pressure at 120 ft amsl.....	37
Figure 25 – Effect of Air Flow on Pressure at Piezometer P1	38
Figure 26 – Piezometer and Well Locations.....	39
Figure 27 – Injection Well Design.....	42
Figure 28 – Piezometer Design	43
Figure 29 – Process and Instrumentation Diagram.....	44

Figure 30 – Gas Supply for the Demonstration	45
Figure 31 – Gas Supply Control Panel	45
Figure 32 – Demonstration Schedule.....	46
Figure 33 – Gas Sampling and Analysis Train	53
Figure 34 – Well Piezometer and Confirmatory Boring Locations	56
Figure 35 – Example Transient Gas Concentrations During Tracer Test 4.....	58
Figure 36 – Summary Analysis of Tracer Test Data.	59
Figure 37 - Oxygen Concentration Transients in Piezometer P3 at 28 ft bgs after Gas Injection Stopped	62
Figure 38 - Average Oxygen Concentrations during N ₂ /H ₂ /LPG/CO ₂ Injection. Error bars are ±1 standard deviation.	63
Figure 39 – Average Hydrogen Concentrations during N ₂ /H ₂ /LPG/CO ₂ Injection. Error bars are ±1 standard deviation.....	64
Figure 40 – Average Hydrogen Concentrations (log scale) during N ₂ /H ₂ /LPG/CO ₂ Injection....	65
Figure 41 – Average Propane Concentrations during N ₂ /H ₂ /LPG/CO ₂ Injection. Error bars are ±1 standard deviation.	66
Figure 42 – Average Oxygen Concentrations during LPG Injection. Error bars are ±1 standard deviation.....	67
Figure 43 – Average Propane Concentrations during LPG Injection. Maximum propane concentration measurable by instrument was 30 percent. Error bars are ±1 standard deviation..	68
Figure 44 – Perchlorate Concentrations 5 to 10 ft bgs.....	69
Figure 45 – Perchlorate Concentrations 15 to 20 ft bgs.....	69
Figure 46 – Perchlorate Concentrations 25 to 30 ft bgs.....	70
Figure 47 – Perchlorate Concentrations 35 to 40 ft bgs.....	70
Figure 48 – Perchlorate Concentrations 45 to 50 ft bgs.....	71
Figure 49 – Perchlorate Concentrations within the 10-ft Target ROI	71
Figure 50 – Nitrate/Nitrite Concentrations 5 to 10 ft bgs	72
Figure 51 – Nitrate/Nitrite Concentrations 15 to 20 ft bgs	72
Figure 52 – Nitrate/Nitrite Concentrations 25 to 30 ft bgs	73
Figure 53 – Nitrate/Nitrite Concentrations 35 to 40 ft bgs	73
Figure 54 – Nitrate/Nitrite Concentrations 45 to 50 ft bgs	74
Figure 55 – Nitrate/Nitrite Concentrations within the 10-ft Target ROI.....	74

Figure 56 – Perchlorate Removal Based on All Data.....	75
Figure 57 – Average Perchlorate Removal Based on All Data	75
Figure 58 – Average Perchlorate Removal within the 10-ft ROI Target.....	76
Figure 59 – Nitrate/Nitrite Removal Based on All Data.....	76
Figure 60 – Average Nitrate/Nitrite Removal Based on All Data	77
Figure 61 – Average Nitrate/Nitrite Removal within 10-ft ROI Target	77
Figure 62 – Heterogeneity of Baseline Perchlorate Concentrations. Error Bars Represent Minimum and Maximum Observed Concentrations.....	79
Figure 63 – Perchlorate Concentration Trends 5 ft East of the Point of Injection.....	79
Figure 64 – Perchlorate Concentration Trends 9 ft North of the Point of Injection	80
Figure 65 – Nitrate plus Nitrite Concentration Trends 5 ft East of the Point of Injection.....	80
Figure 66 – Nitrate plus Nitrite Concentration Trends 9 ft North of the Point of Injection	80
Figure 67 – Relationship between Contaminant Removal and Gas Composition within the 10-ft Target ROI during Phase III mixed N ₂ /H ₂ /LPG/CO ₂ Gas Injection.....	82
Figure 68 – Relationship between Contaminant Removal and Gas Composition within the 10-ft Target ROI during Phase IV LPG Injection	83
Figure 69 – Relationship between Perchlorate Reduction and Oxygen Concentration Inside and Outside the 10-ft Target ROI during Phase III Mixed N ₂ /H ₂ /LPG/CO ₂ Gas Injection	84
Figure 70 – Relationship between Perchlorate Reduction and Hydrogen Concentration Inside and Outside the 10-ft Target ROI during Phase III Mixed N ₂ /H ₂ /LPG/CO ₂ Gas Injection	85
Figure 71 – Relationship between Nitrate Reduction and Oxygen Concentration Inside and Outside the 10-ft Target ROI during Phase III Mixed N ₂ /H ₂ /LPG/CO ₂ Gas Injection	85
Figure 72 – Relationship between Nitrate Reduction and Hydrogen Concentration Inside and Outside the 10-ft Target ROI during Phase III Mixed N ₂ /H ₂ /LPG/CO ₂ Gas Injection	86
Figure 73 – Relationship between Nitrate Reduction and Propane Concentration Inside and Outside the 10-ft Target ROI during Phase III Mixed N ₂ /H ₂ /LPG/CO ₂ Gas Injection	86
Figure 74 – Final Moisture Distribution	87
Figure 75 – Perchlorate Removal within the 10-ft Target ROI at Different Initial Moisture Contents	88
Figure 76 – Perchlorate Removal within the 10-ft Target ROI at Different Final Moisture Contents	88
Figure 77 – Perchlorate Removal Inside and Outside the 10-ft Target ROI at Different Initial Moisture Contents.....	89

Figure 78 – Perchlorate Removal Inside and Outside the 10-ft Target ROI at Different Final Moisture Contents	89
Figure 79 – Nitrate Removal within the 10-ft Target ROI at Different Initial Moisture Contents	90
Figure 80 – Nitrate Removal within the 10-ft Target ROI at Different Final Moisture Contents	90
Figure 81 – Change in Moisture as a Function of Distance from the Point of Injection	91
Figure 82 – Change in Moisture as a Function of Depth	91
Figure 83 – Relationship between Perchlorate Destruction and Baseline Soil Moisture and USCS Soil Type	92
Figure 84 – Relationship between Perchlorate Destruction and Final Soil Moisture and USCS Soil Type	93
Figure 85 - Sensitivity Analyses for Drilling-Related Costs	103
Figure 86 - Sensitivity Analyses for Gas-Related Costs.....	104

Acronyms

AFCEE	Air Force Center for Engineering and the Environment
AGC	Aerojet General Corporation
ASTM	American Society for Testing of Materials
amsl	Above mean sea level
bgs	Below ground surface
BNA	Base, neutral, acidic semi-volatiles
C	Concentration or degrees Celsius
°C	Degrees Celsius
CDM	Camp Dresser & McKee Inc.
CF _i	Coefficient for gas <i>i</i>
cfh	Cubic feet per hour
cfm	cubic feet per minute
ClO ₄ ⁻	Perchlorate
cm ²	Square centimeters
cm ² /s	Square centimeters per second
CO ₂	Carbon dioxide
COTR	Contracting Officer's Technical Representative
cy	Cubic yard
d	Day
DAC	Douglas Aircraft Company
DDT	Dichlorodiphenyltrichloroethane
DoD	Department of Defense
DTSC	California Department of Toxic Substance Control
DWEL	Drinking Water Equivalent Level
DWR	California Department of Water Resources
ELAP	Environmental Laboratory Accreditation Program
EPA	U. S. Environmental Protection Agency
ERDC	U.S. Engineers Research and Development
ESTCP	Environmental Security Technology Certification Program
ft	Feet
GEDIT	Gaseous electron donor injection technology
h	Hours
H ₂	Hydrogen
HMX	High melting explosive
in w.c.	Inches pressure water column
IRCTS	Boeing Interactive Rancho Cordova Test Site
JATO	Jet-assisted take off
LEL	Lower explosive limit
LPG	Liquefied petroleum gas
MCL	Maximum contaminant level
MDC	McDonnell Douglas Corporation
mg/kg	Milligrams per kilogram
mg/kg/d	Milligrams per kilogram per day
mg/L	Milligrams per liter

mg-N/kg	Milligrams of nitrogen per kilogram
min	Minutes
msl	Mean sea level
μg/kg	Micrograms per kilogram
μg/kg/d	Micrograms per kilogram per day
μg/L	Micrograms per liter
N ₂	Nitrogen
NA	Not applicable
NASA	National Aeronautics and Space Administration
ND	Non-detect
NDMA	N-Nitrosodimethylamine
No.	Number
NO ₃ ⁻	Nitrate
OD	Outside diameter
O&M	Operations and maintenance
P	Total pressure
P _i	Actual pressure of gas <i>i</i>
OSHA	Occupational Safety and Health Administration
PBA	Propellant burn area
PCB	Polychlorinated biphenols
PID	Photo-ionization detector
P&ID	Process and instrumentation diagram
ppmv	Parts per million by volume
psig	Pounds per square inch gauge
PSU	The Pennsylvania State University
PVC	Polyvinyl chloride
Q _i	Flow rate of gas <i>i</i> at standard conditions
\hat{Q}_i	Rotameter reading of flow rate of gas <i>i</i> at standard conditions
QAPP	Quality Assurance Project Plan
QAQC	Quality assurance quality control
r ²	Square of the correlation coefficient
RDX	Royal demolition explosive
RfD	Reference dose
RI	Remedial investigation
ROI	Radius of influence
RWQCB	California Regional Water Quality Control Board
scfh	Standard cubic feet per hour
scfm	Standard cubic feet per minute
SM	Standard Methods
SP	Sample point
SVE	Soil vapor extraction
TBD	To be determined
TCA	Trichloroethane
TCE	Trichloroethene
TNB	Trinitrobenzene
TNT	Trinitrotoluene

TOC	Total organic carbon
UIC	Underground Injection Control
USCS	Unified Soil Classification System
U.S. EPA	U. S. Environmental Protection Agency
USGC	U. S. Geological Survey
VOC	Volatile organic compound
WDC	Water Development Corporation

Acknowledgements

This project was funded by the Environmental Security Technology Certification Program (ESTCP). We are very appreciative of the support and encouragement from Drs. Andrea Leeson and Jeff Marqusee. Supplemental funding was provided by the Aerojet General Corporation who also granted access to the demonstration site. The project team wishes to thank Mr. Rodney Fricke of Aerojet for his ongoing support and dedication throughout the project. Mr. Bryan Harre was the Contracting Officer's Technical Representative and provided very helpful comments during project execution. Contact information for individuals involved in this project is provided in Appendix A.

Executive Summary

Background and Technology Description

Perchlorate is a human health concern because of its ability to inhibit iodide uptake by the thyroid. Perchlorate is present in soil, groundwater, and many potable water supplies. Costs for mitigating these perchlorate impacts can be significant; thus demonstration and validation of cost-effective treatment technologies is critical to the Department of Defense (DoD). While extensive research and technology development on the treatment of perchlorate in water has been conducted, limited research and technology development has been focused on perchlorate in soil. Perchlorate contamination in soil is important because of it can be a source of groundwater contamination.

Currently, available technologies for the treatment of perchlorate in soil require excavation and are not always cost-effective or practical, particularly as the depth of contamination increases. When applicable, excavation followed by anaerobic biodegradation has proven to be effective. *In situ* remediation of perchlorate in soil is an alternative, potentially more cost-effective solution.

Gaseous electron donor injection technology or GEDIT (U.S. Patent No. 7,282,149 and patent pending) involves injection of gaseous electron donors into the soil with the purpose of promoting anaerobic biodegradation of perchlorate to water and chloride ion. This technology can be viewed as bioventing in reverse. Bioventing, a proven bioremediation technology for petroleum hydrocarbons, involves the injection of a gaseous electron acceptor (e.g., oxygen) into the vadose zone resulting in the biodegradation of an electron donor (e.g., hydrocarbons). In the present application, the electron acceptor and donor are reversed with the gaseous electron donor being injected in order to biodegrade the electron acceptor (i.e., perchlorate or nitrate).

Bioventing is an effective technology because it relies on the excellent mass transfer characteristics of gases resulting in an effective distribution of oxygen through the vadose zone. Similarly, the injection of gaseous electron donors for perchlorate biodegradation in vadose zone soil benefits from the same mass transfer and distribution characteristics. The superior mass transfer and distribution of gases as compared to liquids is the major advantage of this technology over attempts to introduce liquids into the vadose zone. Diffusion of gases in the vadose zone improves the ability to deliver the electron donor throughout the soil volume and helps to overcome problems associated with liquid flow through preferential pathways. Additionally, gaseous electron donor technology does not require the capture and treatment of infiltrated liquids that could otherwise adversely impact groundwater.

Potential applications of GEDIT include treatment of a wide variety of oxidized contaminants in soil. A partial list of oxidized contaminants that are potentially treatable using GEDIT include:

- Perchlorate
- Chlorate
- Nitrate
- Nitrite

- Selenate
- Arsenate
- Chromate and dichromate (i.e., hexavalent chromium)
- Uranyl
- Perchnetate
- N-Nitrosodimethylamine (NDMA)
- Trichloroethene (TCE)
- Trichloroethane (TCA)
- Highly energetic compounds including nitro-aromatics such as TNT, RDX, and HMX

Many of the limitations or technical risks for this technology are similar to bioventing technology risks when gas injection is used. Additional limitations or technical risks are associated with the use of electron donors that are also flammable chemicals. These risks can be managed in a cost-effective and practical manner.

Performance Objectives and Results

Perchlorate

The demonstration was conducted at the Inactive Rancho Cordova Test Site Propellant Burn Area (IRCTS-PBA) in Rancho Cordova, California. The average percent perchlorate destruction was 93 ± 9 percent within the targeted 10-foot (ft) radius of influence (ROI) and the 10-to-40-ft below ground surface (bgs) depth interval. The performance objective of 90 percent for perchlorate destruction was exceeded. Initial perchlorate concentrations within this ROI and depth ranged from 2,600 to 75,000 micrograms per kilogram ($\mu\text{g}/\text{kg}$). Final perchlorate concentrations ranged from < 13 to 8,800 $\mu\text{g}/\text{kg}$. Seven final soil samples (i.e., six sample locations plus one duplicate) were non-detect (ND) for perchlorate (< 13 to < 15 $\mu\text{g}/\text{kg}$).

Perchlorate destruction was affected by oxygen and hydrogen concentrations. Oxygen concentrations less than about one percent and hydrogen concentrations greater than 0.5 percent supported perchlorate destruction. Liquefied petroleum gas (i.e., commercial propane or LPG) did not support perchlorate destruction. Perchlorate destruction was not affected strongly by differences in soil moisture at this site. Significant perchlorate destruction was observed in soil samples with final moisture contents ranging from 6.8 to 36 percent. Perchlorate destruction was also observed in silty and clayey lower permeability soil types. These data indicate that hydrogen was able to diffuse into low permeability soil pore spaces.

A maximum of five months was required to achieve 93 ± 9 percent perchlorate destruction during the demonstration and three months or less was required in certain locations. The performance objective was 90 percent destruction within twelve months. Thus the performance objective was met. Heterogeneity greatly complicated assessment of actual perchlorate destruction rates. Nevertheless, 88 ± 11 percent perchlorate destruction at a rate of 380 ± 110 micrograms per kilogram per day ($\mu\text{g}/\text{kg}/\text{d}$) was estimated. This rate compares favorably to biodegradation rates measured during optimized full-scale *ex situ* bioremediation of perchlorate in soil where the median rate was about 200 $\mu\text{g}/\text{kg}/\text{d}$ and the 90th percentile rate was about 500 $\mu\text{g}/\text{kg}/\text{d}$.

Nitrate

The average percent nitrate destruction was 94 ± 9 percent within the targeted 10-ft ROI and the 10-to-50-ft bgs depth interval. The performance objective of 90 percent for nitrate destruction was exceeded. When all data were considered which comprised an ROI of 55 ft, the average nitrate destruction was 90 ± 14 percent. Nitrite was analytically quantified as the sum of nitrate and nitrite. Therefore, accumulation of the denitrification intermediate nitrite did not occur. Initial concentrations of nitrate plus nitrite within the 10-ft target ROI ranged from 2.0 to 8.6 milligrams of nitrogen per kilogram (mg-N/kg). Final nitrate plus nitrite concentrations ranged from < 0.054 to 2.9 mg-N/kg. Six final soil samples (i.e., five sample locations plus one duplicate) were ND for nitrate (< 0.054 to < 0.057 mg-N/kg).

Nitrate destruction was affected less so by gas composition than perchlorate. Significant nitrate destruction occurred when oxygen concentrations were less than about ten percent. Nitrate destruction was observed under a wide range of hydrogen concentrations as low as about 0.01 percent and under propane concentrations about three percent or greater.

A maximum of five months was required to achieve 94 ± 9 percent nitrate destruction during the demonstration and three months or less was required in certain locations. The performance objective was 90 percent destruction within six months. Thus the performance objective was met. A nitrate destruction rate of 40 ± 11 $\mu\text{g}/\text{kg}/\text{d}$ was estimated.

ROI was used as a primary metric for implementability because it will determine the number of wells required to treat a given area. The ROI for perchlorate degradation was conservatively estimated to be 10 feet and likely to be 15 ft during the demonstration. The ROI for nitrate degradation was estimated to be at least 55 ft. The performance objective for implementability was an ROI of 10 ft. Therefore the performance objective was met.

These ROIs were based on injection of a total of 100 standard cubic feet per hour (scfh) of gas into a single location at 18 and 28 ft bgs. The ROI for oxygen depletion and electron donor transport was strongly affected by injection well design, gas flow rate, injection strategy. Use of six-inch long soil vapor probes as injection points and continuous injection of gas at relatively low flow rates was preferable to use of long well screens and pulsing of gas at relatively high flow rates.

Gas composition also affected the ROI and the ROI varied with respect to depth. For example, LPG was transported a greater distance than hydrogen during injection of a $\text{H}_2/\text{CO}_2/\text{LPG}/\text{N}_2$ gas mixture. Hydrogen, because of its buoyancy, was limited in how deep it could be transported compared to LPG. The injection of this mixture was effective in reducing oxygen concentrations not only at the injection depths (i.e., 18 and 28 ft bgs), but also above and below these depths based on measured oxygen concentrations and observed perchlorate removals. As compared to injection of the gas mixture, injection of LPG alone was transported significant distances but tended to sink resulting in elevated oxygen concentrations in shallow soil horizons. Thus, the ROI measured for this demonstration was operationally defined and should not be directly applied to other sites. Greater ROIs are possible and the most cost-effective and implementable approach will be determined by optimizing gas injection and well spacing.

Implementation Issues

In addition to well spacing, regulatory acceptance, permitting, and safety are important implementation issues. Federal or state regulations driving site cleanup will drive the need for GEDIT. The primary application for GEDIT is anticipated to be treatment of contaminants such as perchlorate in deep soil for the purpose of groundwater protection. The feasibility study process will include evaluation of GEDIT compared to other alternatives such as pump and treat, liquid flushing, and excavation. Specific permits for GEDIT will be driven by local codes and will include drilling and well installation permits and hazardous materials storage permits. Other permits may be necessary and will be dependent on local codes.

Flammability is the primary end-user concern associated with GEDIT. As shown in this demonstration, this issue was easily managed and did not necessitate unusual efforts. The level of effort was similar to that for a construction site or remediation of a gasoline station site. Specifically, the following observations and actions were part of this demonstration:

- Hydrogen was supplied in cylinders much in the same way that flammable acetylene is supplied for welding at construction sites. The number of cylinders was greater than typically used at a construction site but these cylinders were contained in a commercially available rig that stabilized and manifolded the cylinders.
- LPG was stored in a standard commercially available tank on a portable concrete pad, in accordance with local codes. This effort was no different from a remediation site that uses a propane-fired thermal oxidizer or a construction site that uses LPG.
- Use of flammable gas/no smoking placards were used at the site. Such placards would be present at any site employing the use of flammable chemicals.
- Liquid nitrogen was supplied in a commercially available trailer. From a cold surface hazard perspective, liquid nitrogen is handled the same as liquid oxygen at hospitals and other commercial facilities.
- The Sacramento County Hazardous Materials Department and Aerojet-General Corporation were satisfied with the arrangement for storage and use of flammable materials on the site. A standard hazardous materials permit was required by the County. Aerojet-General Corporation conducted a New Process Evaluation which is a standard requirement and was completed with minimal effort.
- Flammable gases were not detected above the ground surface. Thus, release of flammable gas to the atmosphere was not a safety issue. Nevertheless, monitoring of flammable gases should be conducted just as they would be during a gasoline station remediation project.

Costs

This cost model was based on implementation at the IRCTS-PBA. Four scenarios were considered and compared in this cost assessment. Each scenario has different treatment objectives, gas compositions, and total soil volumes to be treated. Scenarios 1 and 3 have the treatment objective of reducing perchlorate concentrations to 60 µg/kg or less which is a possible California Regional Water Quality Control Board cleanup goal for protection of groundwater at the site. Scenarios 2 and 4 have a less stringent treatment objective of achieving 90 percent mass

reduction of perchlorate. Scenarios 1 and 2 are conservatively designed based on demonstration data and have an ROI of 10 ft and a gas composition based on 10 percent hydrogen. The 10-ft ROI has is the minimum value based on demonstration data. The gas composition comprised of 10 percent hydrogen was used in the demonstration. Scenarios 3 and 4 have an ROI of 15 ft based on limited demonstration data. The gas composition used in Scenarios 3 and 4 is one percent hydrogen and 99 percent nitrogen because LPG was not necessary for perchlorate reduction and hydrogen concentrations as low as 0.5 percent were able to promote perchlorate degradation.

Unit costs for the various scenarios were estimated as follows:

- Scenario 1 represents the costs based on conservative demonstration design conditions and the unit cost is \$87 per cubic yard (\$87/cy).
- Scenario 2 is based on the same gas composition and ROI as in Scenario 1, but the treatment area is reduced with a focus on mass reduction. The unit cost is reduced to \$68/cy under Scenario 2.
- Scenario 3 is comparable to Scenario 1 with respect to the treatment goal and area, but is based on a more reasonable design. These changes reduce the unit cost to \$21/cy.
- Scenario 4 is focused on mass reduction with a reasonable design and the unit cost is \$28/cy. The unit cost for Scenario 4 is greater than for Scenario 3 because the volume of soil is lower and many project costs are fixed.

An alternative approach to *in situ* treatment is excavation of vadose zone soil and ex situ bioremediation. This process includes soil excavation; rock screening and crushing; soil mixing with water, electron donor, and nutrients; storage in treatment cells during biodegradation; soil drying; and backfilling. Full-scale costs for this process were estimated to be about \$35/ton or \$45/cy. Given the depth of the vadose zone at the site (140 ft bgs), the unit cost may be even higher due to the significant benching and sloping required. Compared with this ex situ approach, GEDIT is cost effective under Scenarios 3 and 4. Other alternatives for groundwater protection such as hydraulic containment via pump and treat may also be applicable. Additional evaluations would be necessary to assess whether GEDIT is cost effective in comparison. Nevertheless, well superposition and other refinements are likely to further improve the cost-effectiveness of GEDIT.

1.0 INTRODUCTION

1.1 Background

Thousands of tons of perchlorate (ClO_4^-) have been released into the environment since its first use as a rocket fuel oxidant in the 1950s (Motzer, 2001). Since that time, the highly soluble and weakly adsorptive perchlorate anion has contaminated surface and groundwater throughout the United States, potentially affecting more than 15 million people and causing numerous risks to human health (Xu et al., 2003). Technologies have been developed and implemented for treatment of perchlorate in groundwater and include both *ex situ* and *in situ* anaerobic biological reduction as well as *ex situ* ion exchange.

The U.S. Environmental Protection Agency (U. S. EPA) Office of Solid Waste and Emergency Response, Federal Facilities Restoration and Reuse, has documented 58 federal sites with known perchlorate releases as of April 29, 2004 (U.S. EPA, 2004). These sites include a combination of Air Force, Navy, Army, Department of Energy, and NASA sites. Of these sites, 51 are U.S. Department of Defense (DoD) sites. In addition, the office listed 40 private sites with known releases. Many of the private sites are owned or operated by military contractors. Groundwater contamination exists at all of these sites with perchlorate concentrations as high as 3,700 milligrams per liter (mg/L). Perchlorate in vadose zone soil exists at many of these sites and can serve as ongoing sources of groundwater contamination. Twenty of the 51 DoD sites are listed as having soil contamination. EPA has not defined soil contamination at the remaining sites; however, it is likely that perchlorate exists in vadose zone soils.

Additionally, various DoD contractors have significant soil contamination problems. The former Whittaker-Bermite site north of Los Angeles was formerly used to manufacture jet-assisted take off (JATO) and Sidewinder/Chaparral/N-29 rocket motors and miscellaneous munitions for the DoD. This site is about 1,000 acres with a vadose zone up to 300 feet in depth. Perchlorate and chlorinated volatile organic compounds (VOCs) are present in vadose zone soil. Perchlorate has been detected at depths up to 200 feet (maximum depth sampled) and at concentrations up to 310 mg/kg in Operable Unit 1 alone. The McDonnell Douglas Inactive Rancho Cordova Test site (IRCTS) in California has documented perchlorate contamination in soil. These sources in soil often require treatment because they represent potential human health risks and may serve as ongoing sources of perchlorate in groundwater.

Perchlorate is a human health concern because of its documented ability to inhibit iodide uptake by the thyroid (U.S. EPA, 2005). Perchlorate is present in soil, groundwater, and many potable water supplies across the United States. The perchlorate concentrations in many of these media are greater than regulatory concentrations, as discussed in Section 1.3, and may pose risks to human health. The sources of perchlorate in these media include both naturally occurring and anthropogenic sources. Many but not all of the anthropogenic sources of perchlorate are attributable to DoD and DoD-contractor operations. Costs for mitigating these perchlorate impacts can be significant; thus, demonstration and validation of cost-effective treatment technologies is critical to the DoD.

Currently, available technologies for the treatment of perchlorate in soil require excavation and are not always cost-effective or practical, particularly as the depth of contamination increases.

When applicable, excavation followed by anaerobic composting has proven to be effective. *In situ* remediation of perchlorate in soil is an alternative, potentially more cost-effective solution. Currently, emerging *in situ* technologies for treating perchlorate in soil involve soil flushing with water or liquid electron donors. Flushing the soil with water transfers the contaminant to the aqueous phase which must then be extracted and treated. Flushing with liquid electron donors in most cases will require groundwater extraction and hydraulic containment. Shallow soil has been cost-effectively treated *in situ* using cow manure and other inexpensive electron donors.

Soil flushing technologies are limited by the ability to adequately distribute these liquids throughout the vadose zone, as a result of the tendency for fluids to flow along preferential pathways, and potential difficulty in capturing infiltrated water at certain sites. Additionally, technologies based on infiltration of liquid electron donors become even more difficult to apply as vadose zone contamination extends deeper. Therefore, there is a need for more effective *in situ* perchlorate treatment technologies applicable to vadose zone soil at any depth. Gaseous electron donor injection technology (GEDIT; U.S. Patent No. 7,282,149 and patent pending) involves injection of gases such as hydrogen and propane into the vadose zone to stimulate anaerobic biological reduction of perchlorate to water and chloride. Nitrate and nitrite are also reduced to nitrogen gas. GEDIT takes advantage of the greater diffusivity and lower density of gases compared to liquids to address lithologic heterogeneity issues in the vadose zone. GEDIT is also potentially applicable to treatment of other DoD and Department of Energy related contaminants such as hexavalent chromium, uranium, technetium, and highly energetic compounds including TNT, RDX, and HMX.

1.2 Objective of the Demonstration

The overarching objective of this project was to demonstrate and validate GEDIT for treatment of perchlorate and nitrate in vadose zone soil. This project represents the first field demonstration of the technology. The demonstration yielded valuable engineering design information on GEDIT implementation. Development of an engineering guidance document was another objective of the project. Performance objectives for the project are described in Section 3.0.

1.3 Regulatory Drivers

The primary driver for cleanup of perchlorate in soil is protection of groundwater. Cleanup levels for perchlorate in soil based on ingestion of direct contact are typically much greater than those for protection of groundwater. One exception is shallow soil where food crops are grown. In this case certain crops such as lettuce can take up perchlorate and result in another route of exposure.

With respect to protection of groundwater, the U.S. EPA is in the process of evaluating whether to establish a maximum contaminant limit (MCL) for perchlorate in drinking water. The current drinking water equivalent level (DWEL) is 24.5 µg/L which is based on a reference dose (RfD) of 0.0007 mg/kg/day (U.S. EPA, 2006a). If the EPA establishes an MCL for perchlorate, the current DWEL may or may not be used as the value for the MCL. Currently, U.S. EPA has established an interim drinking water health advisory level of 15 µg/L for perchlorate (U.S. EPA, 2008). Individual states vary in their regulation of perchlorate in drinking water. California has established an MCL of 6 µg/L and Massachusetts has established an MCL of 2 µg/L. Other states vary with respect to how they regulate perchlorate and very few states have specific

regulatory limits for perchlorate in soil (ITRC, 2005). Most commonly, cleanup limits for perchlorate in soil are established on a site-by-site basis and can be as stringent as non-detect in order to protect groundwater. Several factors affect development of cleanup levels for protection to groundwater. These can include depth to groundwater, hydrogeology, depth of perchlorate contamination, rainfall, surface water infiltration, and soil lithology.

2.0 TECHNOLOGY

2.1 Technology Description

GEDIT involves injection of gaseous electron donors into the soil with the purpose of promoting anaerobic bioremediation of perchlorate to water and chloride ion. This technology can be viewed as bioventing in reverse as illustrated in Figure 1. Bioventing, a proven bioremediation technology for petroleum hydrocarbons, involves the injection of a gaseous electron acceptor (e.g., oxygen) into the vadose zone resulting in the biodegradation of an electron donor (e.g., hydrocarbons). In the present application, the electron acceptor and donor are reversed with the gaseous electron donor being injected in order to biodegrade the electron acceptor (i.e., perchlorate or nitrate).

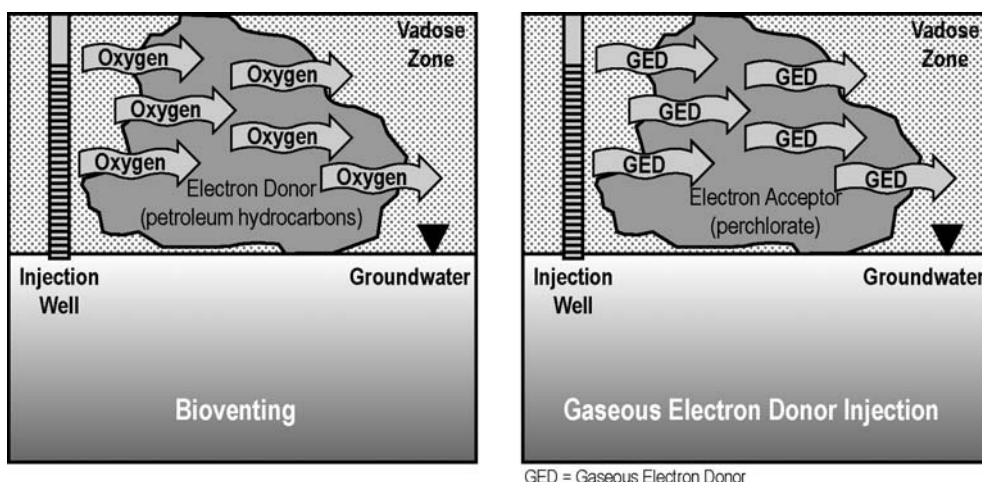

Figure 1 – Comparison of Bioventing and Gaseous Electron Donor Injection Technology

Bioventing is an effective technology because it relies on the excellent mass transfer characteristics of gases resulting in an effective distribution of oxygen through the vadose zone. Similarly, the injection of gaseous electron donors for perchlorate biodegradation in vadose zone soil benefits from these same mass transfer and distribution characteristics.

GEDIT involves injection of gaseous electron donors into the soil using injection wells in combination with optional soil vapor extraction wells. These gaseous electron donors can include hydrogen, propane, or volatile organic compounds such as methanol, ethanol, butanol, acetic acid, ethyl acetate, butyl acetate, hexene, etc. The injected concentration of the electron donor is less than its saturation vapor pressure so that the injected electron donor truly exists as a gas and not as a mist. As the gaseous electron donor material is injected into the vadose zone it partitions between soil moisture and the vadose zone pore space. After it has partitioned into the soil moisture, anaerobic, perchlorate-reducing bacteria can use the electron donor to reductively degrade perchlorate. Any soil nitrate or oxygen that is present in the pore space will also be reduced using the injected gaseous electron donor. The rate at which the gaseous electron donor

is transported through the vadose zone is primarily a function of soil moisture, electron donor Henry's constant, void volume, bulk soil density, bulk gas velocity, soil permeability, and biodegradation rate (Evans and Trute, 2006). GEDIT is similar to anaerobic bioventing (U.S. EPA, 2006b). Anaerobic bioventing has been described to involve injection of hydrogen and carbon dioxide into soil to promote anaerobic biodegradation of organic contaminants including chlorinated hydrocarbons and dichlorodiphenyltrichloroethane (DDT). GEDIT can include use of hydrogen/carbon dioxide and can additionally use liquid electron donors that can be vaporized into a gaseous carrier stream.

GEDIT can be implemented in various configurations two of which are illustrated in Figures 2 and 3. In the gas injection configuration, nitrogen from a generator or a liquid nitrogen supply is amended with gaseous electron donor and then injected into the perchlorate-impacted vadose zone. The presence of nitrogen serves to flush oxygen from the soil gas, enhancing conditions for the degradation of perchlorate. In the SVE configuration, soil vapor is extracted, amended with gaseous electron donor, and then injected back into the perchlorate-impacted vadose zone. As the reductive degradation of perchlorate progresses, the oxygen content of the extracted soil is reduced, thereby facilitating further perchlorate degradation. Well spacing for both of the configurations will depend on the pneumatic radius of influence and the specific gaseous electron donor selected for use.

Potential applications of GEDIT include treatment of a wide variety of oxidized contaminants in soil. A partial list of oxidized contaminants that are potentially treatable using GEDIT include:

- Perchlorate
- Chlorate
- Nitrate
- Nitrite
- Selenate
- Arsenate
- Chromate and dichromate (i.e., hexavalent chromium)
- Uranyl
- Pertechnetate
- N-Nitrosodimethylamine (NDMA)
- Trichloroethene (TCE)
- Trichloroethane (TCA)
- Highly energetic compounds including nitro-aromatics such as TNT, RDX, and HMX.

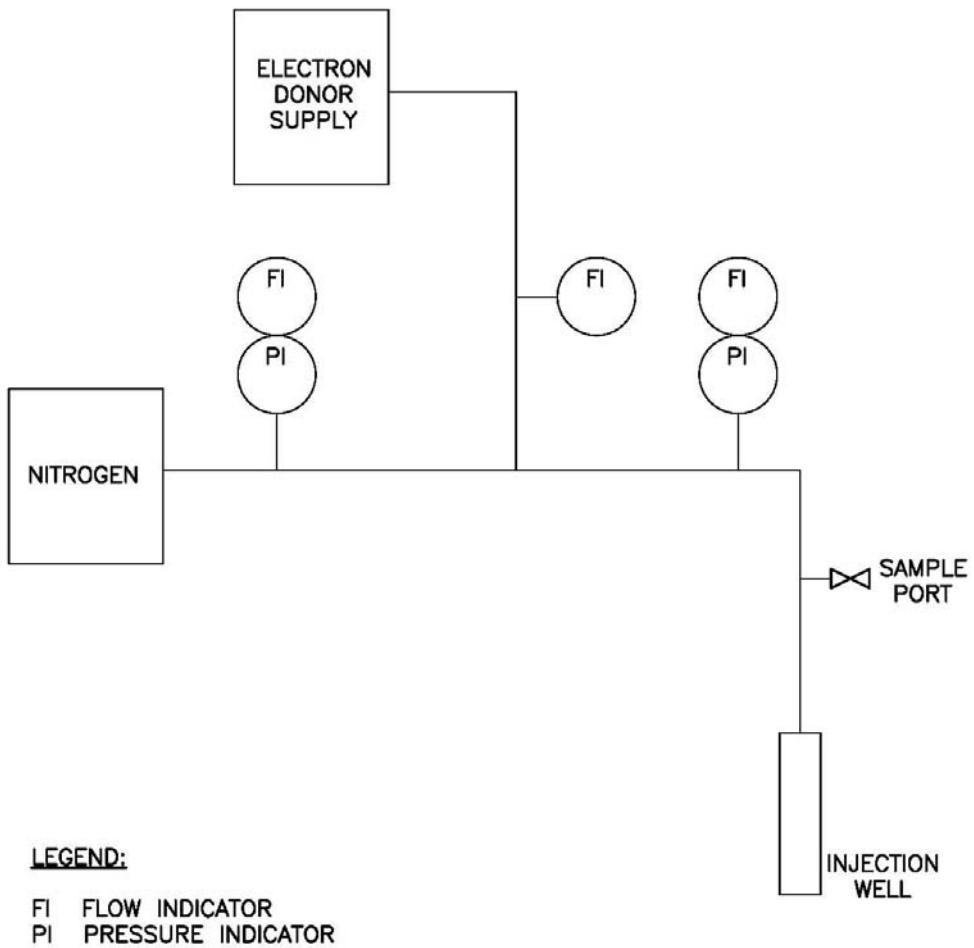
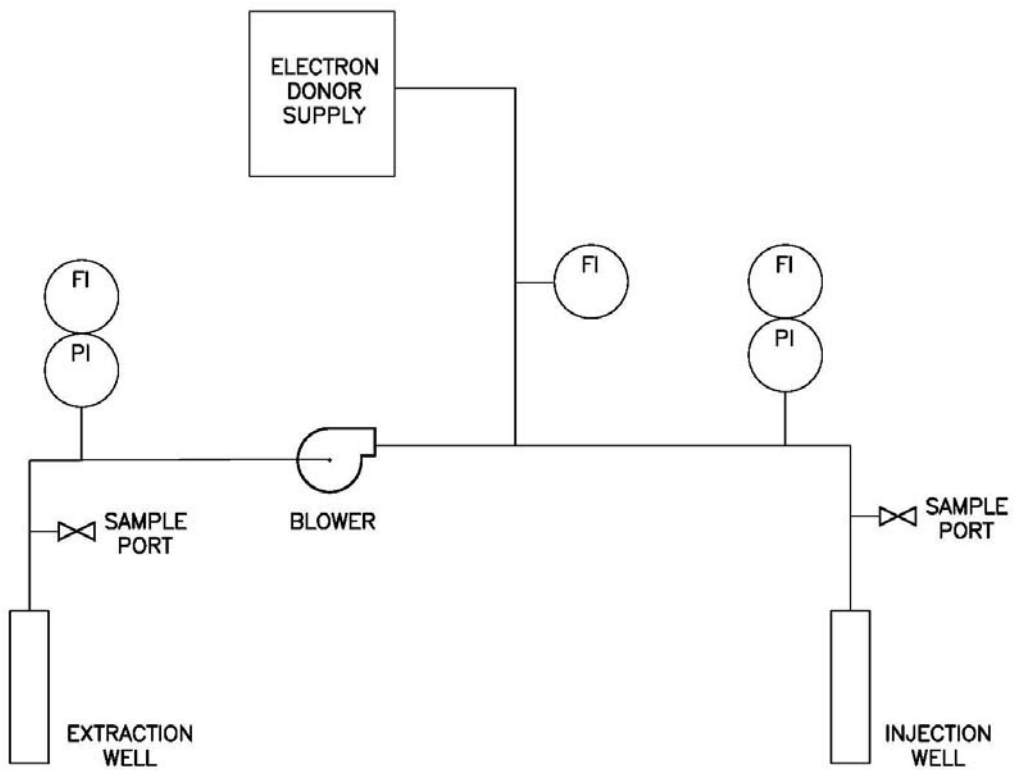

Figure 2 – Example Gas Injection GEDIT Process and Instrumentation Diagram



LEGEND:

FI FLOW INDICATOR
 PI PRESSURE INDICATOR

Figure 3 – Example SVE GEDIT Process and Instrumentation Diagram

2.2 Technology Development

A chronological summary of GEDIT development is presented in Table 1.

Table 1 – Chronological Summary of Technology Development

2002	GEDIT concept conceived by CDM and perchlorate reduction in microcosms demonstrated.
2003	Work plan for GEDIT pilot test at the former Bermite site in California submitted to and accepted by California Department of Toxic Substances Control (DTSC).
2003 – 2004	Additional development of GEDIT including evaluation of various electron donors with respect to promoting perchlorate biodegradation and transport through soil.
2005	Conducted conceptual design and cost estimate for full-scale GEDIT implementation at the Inactive Rancho Cordova Test site (IRCTS) in California.
2006	GEDIT concept, research results, and economics published (Evans and Trute, 2006).
2007	U.S. Patent No. 7,282,149 issued to CDM for GEDIT.
2007	Conducted ESTCP demonstration of GEDIT at IRCST-PBA
2008	Work plan for GEDIT pilot test at the former Bermite site in California revised and accepted by DTSC.

GEDIT technology development has been described in detail previously (Evans and Trute, 2006; Evans 2007). A brief summary of this development is presented below.

Vadose zone soil microcosms amended with ethanol or hydrogen and carbon dioxide as an electron donor were demonstrated to result in complete nitrate biodegradation within 34 days (Evans and Trute, 2006). Complete perchlorate biodegradation required a longer period of time – 105 days. The soil moisture content was an important factor affecting the rate of nitrate and perchlorate biodegradation but nutrient amendment was not important with this particular soil.

Column studies demonstrated widely varying transport rates of different electron donors through moist soil (Evans and Trute, 2006). Primary factors affecting transport included soil moisture, electron donor Henry's constant, void volume, bulk soil density, bulk gas velocity, soil permeability, and biodegradation rate. For example, hydrogen and propane are transported through moist soil rapidly because they do not partition significantly into soil moisture. On the other hand, ethanol vapor is transported slowly through moist soil because it partitions into soil moisture. Ethyl acetate is transported at an intermediate rate – it does not partition into soil moisture as extensively as ethanol but can decompose to ethanol and acetic acid by hydrolysis.

Previous work by the U.S. Engineer Research and Development Center (ERDC) has demonstrated that gaseous electron donors including ethanol, acetone, and isobutyl acetate can promote biodegradation of RDX and trinitrobenzene (TNB) (Rainwater et al., 2001). Thus, GEDIT is potentially applicable to energetic range contaminants including TNT, RDX, and HMX in addition to perchlorate and nitrate. Hydrogen has also been shown to be capable of promoting biological transformation of TNT (McCormick et al., 1976). Ethanol, acetone, isobutyl acetate, and hydrogen are applicable to GEDIT. The biological reduction of VOCs using hydrogen in groundwater has been pioneered by the Air Force Center for Engineering and the Environment (AFCEE). Use of hydrogen in the vadose zone is also possible provided that sufficiently anaerobic conditions for reductive dechlorination can be attained. Thus GEDIT may also be applicable to treatment of VOCs. In general, any contaminant that can be anaerobically biodegraded is a potential candidate for GEDIT.

2.3 Advantages and Limitations of the Technology

Bioventing is an effective technology because it relies on the excellent mass transfer characteristics of gases and their ability to distribute oxygen through the vadose zone. Similarly, GEDIT benefits from these same gas mass transfer and distribution characteristics.

The superior mass transfer and distribution of gases as compared to liquids is the major advantage of this technology over attempts to introduce liquids into the vadose zone. Diffusion of gases in the vadose zone improves the ability to deliver the electron donor throughout the soil volume and helps to overcome problems associated with liquid flow through preferential pathways. Additionally, GEDIT does not require the capture and treatment of infiltrated liquids that could otherwise adversely impact groundwater. In projects involving liquid electron donors, the infiltration of these electron donors to groundwater can result in mobilization of naturally occurring metals in soil minerals including iron, manganese, and arsenic. GEDIT has the advantage of not promoting metal mobilization to groundwater. Other than liquid infiltration, the only alternative technologies to GEDIT are excavation for soil and hydraulic containment for impacted groundwater.

Many of the limitations or technical risks for this technology are similar to bioventing technology risks when gas injection is used. Additional limitations or technical risks are associated with the use of electron donors that are also flammable chemicals. Other limitations or technical risks are associated with the nature of sampling and analysis of heterogeneous soils. These and other limitations and risks along with relevant responses are documented in Table 2.

Table 2 – Technical Limitations and Risks

Limitation or Risk	Responses
Very shallow soil	Implement excavation and ex situ treatment or surface amendment of liquid or solid electron donors if more cost-effective
Residual electron donor in soil	Operate in bioventing mode to introduce air into vadose zone and promote aerobic biodegradation
Too low moisture content in soil to support biodegradation	Recognize limits of technology and determine appropriate application. Increasing moisture in situ is infeasible.
Too high perchlorate in soil to support biodegradation	Recognize limits of technology and determine appropriate application
Inhibitory conditions such as low pH	Recognize limits of technology and determine appropriate application
Soil drying during gas injection	This is a perceived risk that has not been demonstrated to occur under actual site conditions.
Difficulty in data interpretation because of heterogeneous concentration distribution in soil	Conduct site characterization and develop sound sampling and analysis plan based on statistical soil sampling methods. Collect baseline and final soil samples as close to each other as practical.
Vapor migration to basements	Use appropriate extraction wells to contain vapors. Use sentinel wells to monitor vapors.
Electron donor flammability	Follow National Electrical Code for Class I/Division II conditions.
High oxygen in pore space	Inject sufficient electron donor and/or carrier gas to overcome demand and/or oxygen infiltration.
Oxygen infiltration into vadose zone during operation	Use correctly designed wells and balance injection and extraction rates. Use plastic sheeting as ground cover to minimize air infiltration.

3.0 PERFORMANCE OBJECTIVES

The performance objectives that were established in the Technology Demonstration Plan (CDM, 2007) are presented in Table 3. All of the performance objectives for this demonstration were met. This section describes the each performance objective specifically with respect to the following:

- A full explanation of the objective
- A statement as to what data were collected to evaluate the performance objectives
- A statement as to how the data were interpreted and to what extent the success criteria were met.

Table 3 – Performance Objectives

Performance Objective	Data Requirements	Success Criteria	Results
Quantitative Performance Objectives			
Perchlorate Destruction	Pre- and post-treatment contaminant concentrations in soil	Average 90 percent reduction in perchlorate concentration within the radius of influence (ROI) for electron donor transport	93±9 percent reduction observed within 10 ft from P4 injection point at depths of 10 to 40 ft bgs.
Nitrate Destruction	Pre- and post-treatment contaminant concentrations in soil	Average 90 percent reduction in nitrate/nitrite concentration within the ROI for electron donor transport	94±9 percent reduction observed within 10 ft from P4 injection point at depths of 10 to 50 ft bgs. 90±14 percent reduction observed within 56 ft from P4 injection point at depths of 10 to 50 ft bgs.
Perchlorate Destruction Rate	Pre- and post-treatment contaminant concentrations in soil	Average 90 percent perchlorate reduction within 12 months	88±11 percent reduction observed in 3 months based on comparison of confirmation boring CB3 concentrations to baseline concentrations. 93±9 percent reduction observed in 5 months or less based on the total duration of hydrogen injection.
Nitrate/Nitrite Destruction Rate	Pre- and post-treatment contaminant concentrations in soil	Average 90 percent nitrate/nitrite reduction within 6 months	93±5 percent reduction observed in 3 months based on comparison of confirmation boring CB3 concentrations to baseline concentrations

Table 3 – Performance Objectives (Continued)

Performance Objective	Data Requirements	Success Criteria	Results
Implementability	Hydrogen, propane, and oxygen concentrations in piezometers	ROI for electron donor transport > 10 ft in permeable zones	<ul style="list-style-type: none"> Hydrogen and propane observed up to 56 ft away from injection point. Oxygen depletion up to 56 ft away from injection point. Significant perchlorate destruction was observed at distances up to 15 ft from the injection point. Conservative ROI for consistent hydrogen distribution and oxygen depletion was at least 10 ft and likely 15 ft. With respect to conditions for nitrate destruction the ROI was at least 56 ft.
Qualitative Performance Objectives			
Safety	<ul style="list-style-type: none"> OSHA Reporting Ambient gas concentration 	No reportable health and safety incidents, ambient above-ground air concentration of total hydrocarbons < 10 percent of the lower explosive limit (LEL)	<ul style="list-style-type: none"> No health and safety incidents Ambient concentrations of hydrogen and propane were non-detectable (i.e., less than 0.1 percent and 0.5 percent, respectively) and less than 10 percent of the LEL.
Regulatory Acceptance	Letter of acceptance from regulatory agency	Demonstration approval, acceptance, or concurrence by regulatory agency	<ul style="list-style-type: none"> Technology Demonstration Plan approved by California Regional Water Quality Control Board Storage and use of flammable gases approved by County of Sacramento Hazardous Materials Division
Ease of Use	Feedback from field technician on usability of technology and time required	A single field technician able to effectively take measurements	A single field technician operated the system and collected data. site visits during normal operations were once every week or once every two weeks.

3.1 Perchlorate Destruction

Perchlorate destruction was defined as the percent reduction in perchlorate concentration in soil within the radius of influence (ROI) for gaseous electron donor transport and oxygen depletion. As described in Section 3.5 below, this ROI was conservatively estimated at 10 feet. In addition, the depth of electron donor transport was estimated to be 40 ft. Therefore, the zone of influence used to estimate perchlorate destruction was a cylinder with a 10 ft radius and a 40 ft length that was centered at gas injection piezometer P4.

Data collected to evaluate perchlorate destruction included perchlorate concentrations in soil samples from the borings within the zone of influence. Initial perchlorate concentrations were measured in soil samples collected from borings conducted to install piezometers and wells within the 10-ft ROI. These included P3, P4, P5, and INJ2. Discrete sampling depths included 10, 20, 30, and 40 ft bgs. Final perchlorate concentrations were measured in soil samples from borings conducted adjacent to the initial borings. These borings included CB-17, CB-14, CB-15, and CB-16, respectively. Discrete sampling depths included 10, 20, 30, and 40 ft bgs.

Percent perchlorate removal was calculated for each initial-final data pair. The percent removals were averaged and standard deviations were calculated. The result (93 ± 9 percent) compared favorably to the goal of 90 percent. The metric for this performance objective was met.

3.2 Nitrate Destruction

Nitrate destruction was defined similarly to perchlorate destruction with two exceptions. Since nitrite can transiently accumulate during denitrification, nitrate destruction was quantified using the sum of nitrate and nitrite concentrations. Additionally, the depth of influence for nitrate destruction was 50 ft compared to 40 ft for perchlorate destruction. Therefore soil samples collected from 50 ft bgs were also used in the data analysis. Otherwise, the approach for determining nitrate destruction was as described in Section 3.1.

Percent nitrate removal was 94 ± 9 percent and compared favorably to the goal of 90 percent. When all of the data were considered (i.e., up to 55 ft ROI), the percent removal was 90 ± 14 percent. The metric for this performance objective was met.

3.3 Perchlorate Destruction Rate

The performance objective for the rate of perchlorate destruction was based on the time required to attain a 90 percent reduction in perchlorate concentration.

As discussed in Section 5.7.5, soil heterogeneity complicated assessment of temporal trends of perchlorate concentration. Final assessment of overall perchlorate destruction was described in Section 3.1. Intermediate soil sampling and analysis events were used to develop trends in perchlorate concentration. These data only allowed a rough assessment of perchlorate concentration trends because of heterogeneity.

Nevertheless, the 90 percent removal metric appears to have been attained within five months of operation and at some locations in about three months. This result compares favorably with the 12-month performance objective. Actual perchlorate degradation rates were also calculated and are described in Section 5.7.5. The metric for this performance objective was met.

3.4 Nitrate Destruction Rate

The performance objective for the rate of nitrate destruction was similar to that for perchlorate except that the sum of nitrate and nitrite was used in the assessment. The performance metric for this objective was met – within three months 93 percent nitrate+nitrite removal was observed at CB3.

3.5 Implementability

In situ destruction of perchlorate using GEDIT requires distribution of electron donors and reduction of oxygen concentrations. Achieving these requirements at a given site is affected by injection well spacing/design and gas flow rates. In general, a greater well spacing or ROI is desirable and considered more implementable. Therefore the ROI was used as a performance objective for implementability.

The concentrations of electron donors and oxygen in soil gas and perchlorate and nitrate/nitrite in soil were used to estimate the ROI. The ROI for the demonstration was based on the distance from the point of injection where favorable gas compositions existed and perchlorate destruction was 90 percent or greater.

Electron donor concentrations decreased and oxygen concentrations increased as the distance from the injection point increased. Hydrogen concentrations were generally greater than 0.5 percent at distances up to 10 to 20 ft from the point of injection and depths 10 ft below the point of injection. Oxygen concentrations were generally less than four percent at distances up to 10 to 20 ft from the point of injection. Perchlorate destruction was observed at least 10 ft away from the point of injection and nitrate/nitrite injection at least 55 ft away. Based on these data, the ROI is conservatively estimated at 10 ft and likely to be 15 ft for perchlorate destruction. This estimate compares favorably with the performance objective of 10 ft. The ROI is strongly a function of gas flow rate and will increase with greater flow rates. The metric for this performance objective was met. The ROI for nitrate destruction was at least 55 ft.

3.6 Safety

Safety is very important and the topic of flammability is often brought up with respect to GEDIT. GEDIT employed the hydrogen and LPG in this demonstration. Safe use of these flammable gases necessitated reasonable engineering design considerations, use of intrinsically safe monitoring equipment, placarding in the area to prevent sources of ignition, and appropriate health and safety training.

Metrics for meeting the safety performance objective included OSHA reportable health and safety incidents and flammable gas concentrations above the ground surface.

No health and safety incidents occurred during the demonstration and flammable gas concentrations above the ground surface were not detectable. While concerns regarding GEDIT safety are reasonable, the results of this demonstration indicate the technology can be implemented safely. The metric for this performance objective was met.

3.7 Regulatory Acceptance

This performance objective was defined as permission by the regulatory agency to install and operate the GEDIT system. One consideration in gaining acceptance was whether Waste Discharge Requirements (WDR) – the California equivalent of the U.S. EPA Underground Injection Control (UIC) program – would be applicable.

The California Regional Water Quality Control Board (RWQCB) approved the Technology Demonstration Plan (CDM, 2007) which constituted a work plan for this project. WDR was not required because injection into groundwater was not proposed or conducted. The metric for this performance objective was met.

3.8 Ease of Use

Ease of use is a qualitative performance objective that was based on operational requirements. The metric for this performance objective was the frequency at which an operator needed to visit the site. The reasons for site visitation during normal operations included gas cylinder change-outs and monitoring. This occurred once per week or every other week, which is considered reasonable. The metric for this performance objective was met.

4.0 SITE DESCRIPTION

The information presented in this section is based on previously published reports (AGC & Simon HSI, 1993; Aerojet & HSI GeoTrans, 2000). The Technology Demonstration Plan (CDM, 2007) was based on data provided in these reports. Additional information and data have since been collected for the site. Therefore, the data and historical figures presented below should not be considered to be completely representative of current site conditions. Nevertheless, the data presented in the historical reports are considered adequate for planning and execution of this technology demonstration.

4.1 Site Location and History

The demonstration was conducted at the Propellant Burn Area (PBA) within the Inactive Rancho Cordova Test site (IRCTS) which is located approximately 15 miles east of Sacramento (Figure 4). The PBA is located in the northwestern quadrant of the IRCTS. The PBA comprises approximately 8 acres of undeveloped land within the IRCTS. An east-west unpaved road passes through the approximate center of the PBA (Figure 5). The PBA boundary was determined by reviewing aerial photographs and by identifying residual metallic debris relative to topography, road access, and access barriers (steep dredge valleys and cobble piles).

Prior to purchase by Aerojet, the IRCTS was used for agricultural and mining purposes. During the 1940s, the PBA was dredged to a depth of approximately 70 feet to remove gold from the subsurface gravel deposits. Dredge tailings occupy 60 to 70 percent of the IRCTS, including the entire PBA and vicinity.

In 1956, the IRCTS was purchased by Aerojet General Corporation (AGC) and in 1961, Douglas Aircraft Company (DAC) purchased the property from AGC to establish a static rocket test facility. From 1957 through 1969, DAC and later McDonnell Douglas Corporation (MDC) assembled and static tested various rocket systems at facilities to the south and east of the PBA. The PBA was used by both AGC and MDC to incinerate solid and liquid waste rocket propellant and other waste materials (Aerojet & Simon HSI, 1993). Other wastes consist of non-specific laboratory chemicals. Known constituents include ammonium perchlorate, aluminum, some metals, and solvents, such as trichloroethene (TCE). Solid propellants within large motor casings were ignited within the U-shaped revetment containing a small concrete pad with metal strap-downs. Solid propellant within small casings and solid propellant fragments were ignited on the southeast side of the PBA. Liquid propellant was ignited in troughs (split rocket casings) on the north side of the revetment.

Since 1969, the IRCTS, including the PBA, has been inactive with respect to aerospace activities. In 1984, AGC re-acquired the IRCTS from MDC. Based on a review of available aerial photographs and limited records, the PBA appears to have been used intermittently between 1957 and 1963.

Gold dredging has affected topography at the PBA, creating low, hummocky topography on the south and east, and higher north-south trending windrows of cobbles on the north and west. Elevations range from approximately 196 feet above mean sea level (msl) at the top of the revetment and the dredge tailings windrow on the northeast side of the PBA, to approximately

168 feet in the shallow depression in the southwest quadrant of the PBA. The road level elevation ranges between 180 and 185 feet above msl. The area immediately around the revetment has been graded relatively flat.

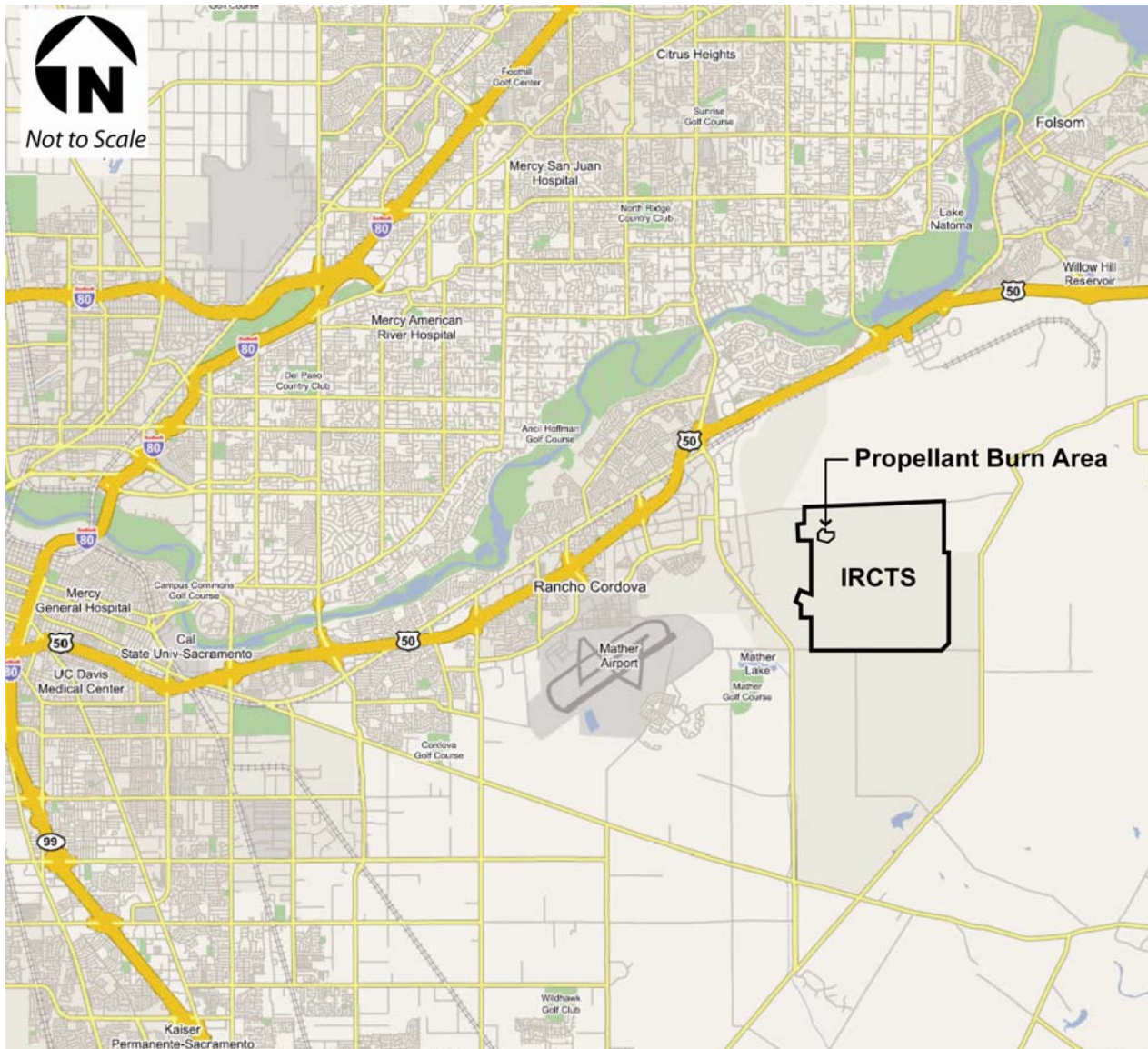
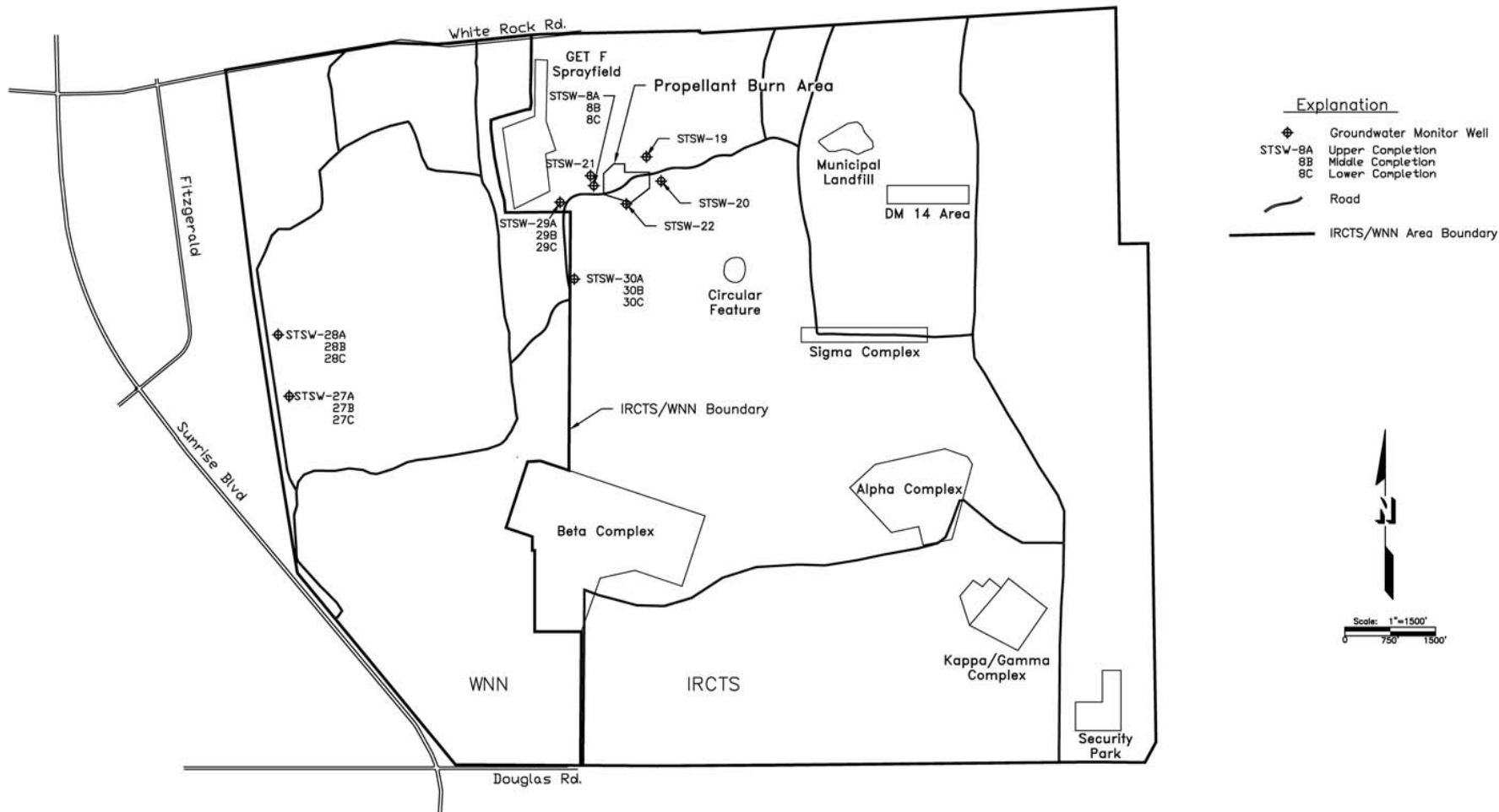

Figure 4 – Vicinity Map, Inactive Rancho Cordova Test Site



SOURCE: HSI GEOTRANS, 2000, IRCTS-PBA RI, FIGURE 1-2

Figure 5 – IRCTS Site Map

4.2 Site Geology/Hydrogeology

4.2.1 Site Geology

The PBA and immediate vicinity are underlain by dredge tailings, which are composed of an unconsolidated mixture of sand and gravel with cobbles and small boulders. A veneer of slickens is present in topographic lows. Well logs indicate that the dredged material extends to depths of at least 70 feet and overlies a layer of silt and clay. This layer overlies more sands and gravels. A PBA site plan and associated cross-section are shown on Figures 6 through 8. These subsurface materials are comprised of the Pliocene-age Laguna Formation, which overlies the Miocene-age Mehrten Formation. Both formations were deposited under fluvial conditions, creating inter-bedded layers of gravels, sands, silts, and minor clays, dipping slightly (approximately one degree) to the west-southwest. The Laguna Formation is derived from granitic and metamorphic sources, while the Mehrten Formation is derived from andesitic sources (Wagner, et al., 1981).

4.2.2 Site Hydrogeology

The earliest characterization of the hydrogeology in the vicinity of the IRCTS was conducted by the California Department of Water Resources (California DWR, 1964), based on more than 300 water-supply wells scattered across more than 100 square miles, including five wells within the IRCTS and 16 wells within one mile of the IRCTS. The DWR bulletin showed that groundwater beneath the PBA was flowing toward the west and west-southwest during 1962 and 1963, respectively, under gradients of 0.0038 and 0.0051 ft per ft. In addition, water level elevations in 1962 to 1963 were approximately 40 feet higher than water level elevations during February 1998.

Groundwater levels fluctuate seasonally, and since 1992, have typically varied between three and four feet over a total range of approximately eight feet. Water level elevations have decreased 25 to 35 feet since the early 1960s. This decline is probably due to several factors, including reduced recharge after the termination of dredging operations in 1962 and increased groundwater pumping for municipal use. Depth to groundwater in the PBA was about 120 to 130 feet below ground surface in 1998. This depth is 50 feet or more below the GEDIT injection zone for this demonstration.

Surface drainage is controlled by the topography and coarseness of the dredge tailings. Most precipitation into the dredge tailings infiltrates rapidly rather than flowing overland. Vertical movement of water in dredge tailings may vary from two inches to more than 20 inches per hour (SCS, 1993). Surface water may pond briefly prior to infiltration in low-lying areas that contain fine-grained materials (i.e., slickens) from the dredging. No perennial streams, pools or bodies of surface water exist in the vicinity of the PBA (USGS, 1980). One seasonal wetland depression exists within the PBA (Gibson & Skordal, 1999). Vernal pools are not present in the vicinity of the PBA (ENSR, 1993; F&WS, 1994; Coy, 1996; Gibson & Skordal, 1999).

Recharge to the shallow groundwater table is primarily from infiltration of precipitation, and the amount of recharge is greater in the areas of coarse dredge tailings than areas with undisturbed

ground. The deeper groundwater is recharged by two sources: vertical flow from the shallow groundwater aquifer and under flow from up-gradient. Water level data indicate that shallow groundwater partially recharges deeper groundwater, as there is a downward vertical gradient between the wells. Deeper groundwater receives recharge directly from precipitation to the east of the PBA, where that aquifer is closest to the ground surface.

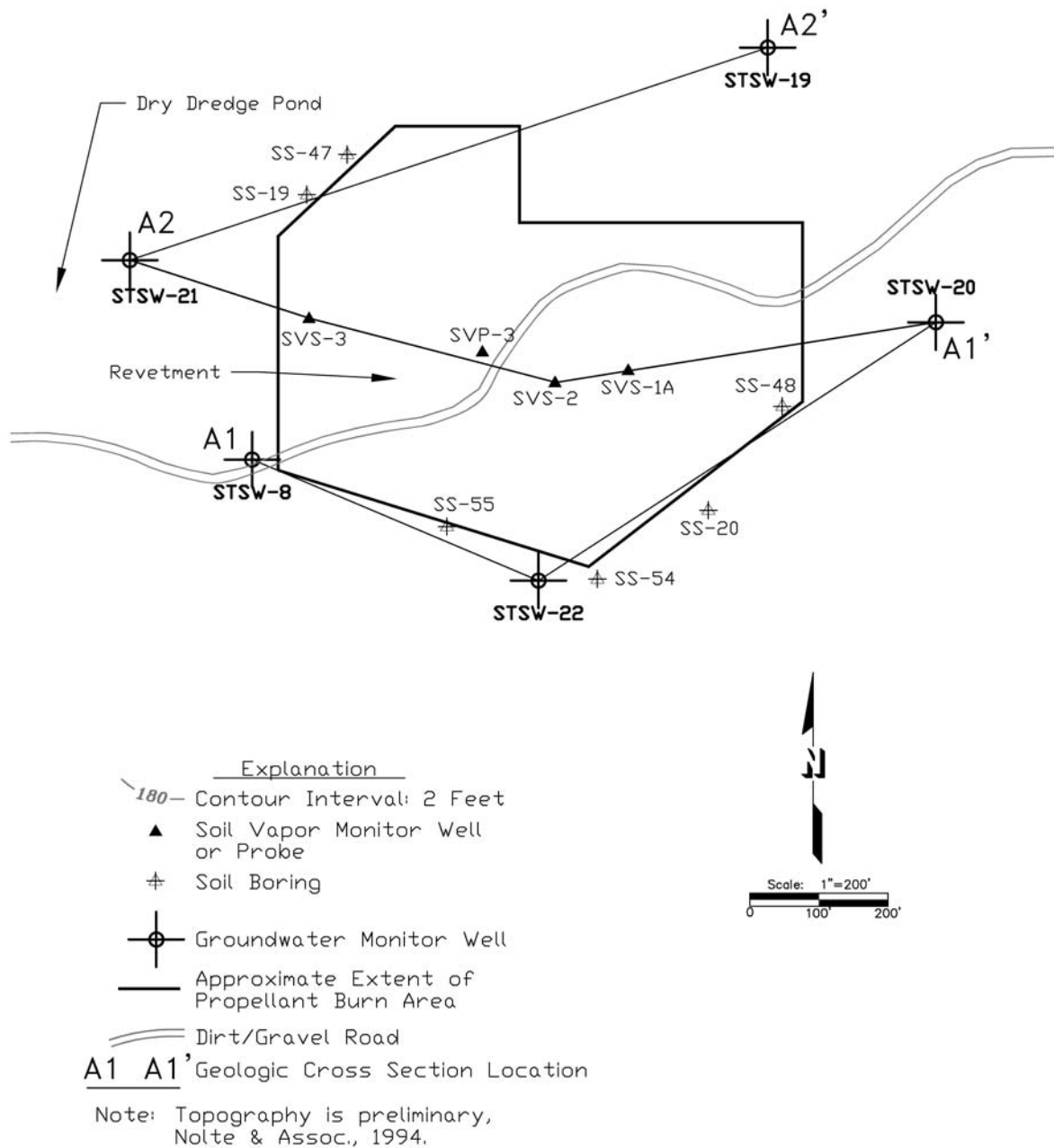

SOURCE: HSI GEOTRANS, 2000, IRCTS-PBA RI, FIGURE 2-1

Figure 6 – Cross-Section Locations

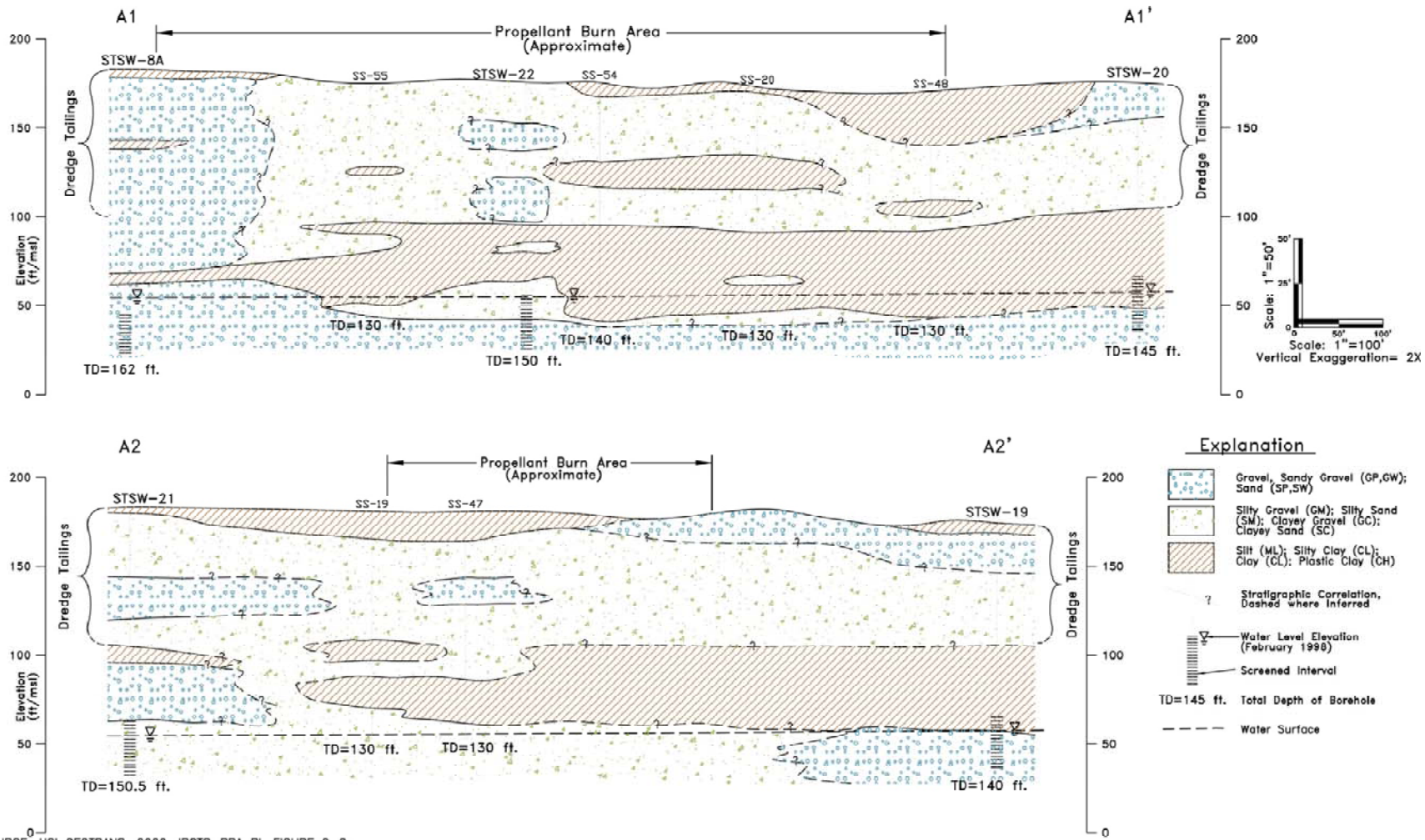

SOURCE: HSI GEOTRANS, 2000, IRCTS-PBA RI, FIGURE 2-2a

Figure 7 – Generalized Lithologic Cross-Sections A1-A1' and A2-A2'

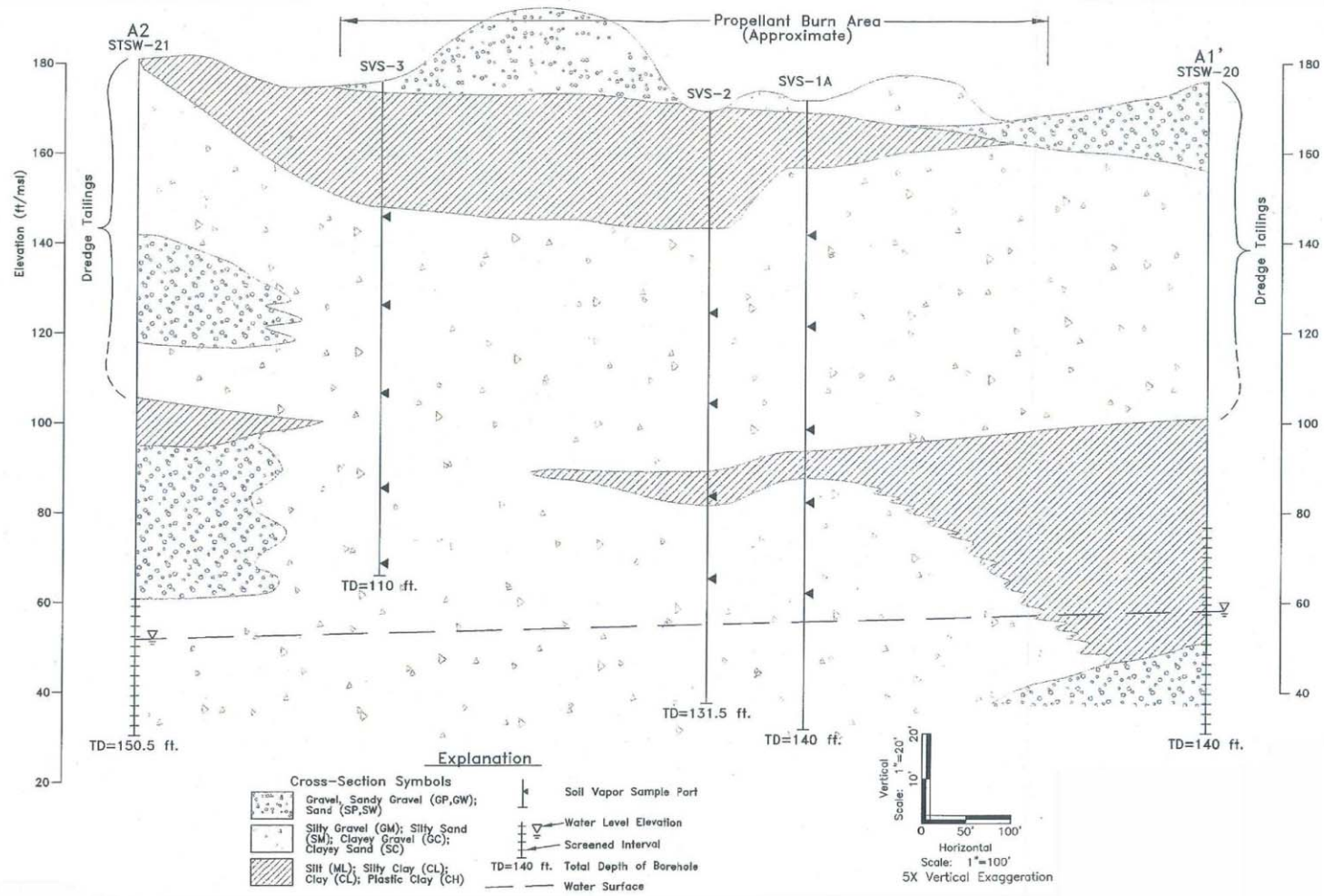

SOURCE: HSI GEOTRANS, 2000, IRCTS-PBA RI, FIGURE 2-2b

Figure 8 – Generalized Lithologic Cross-Section A2-A1'

4.3 Contaminant Distribution

Based on soil and groundwater investigations, the following chemicals have been detected at the PBA: perchlorate, polychlorinated dibenzodioxins/dibenzofurans (dioxins/furans), VOCs, specifically TCE, metals, basic, neutral, and acidic semi-volatiles (BNAs) and polychlorinated biphenyls (PCBs) (Aerojet & HSI GeoTrans, 2000). Site characterization and the baseline health and ecological risk assessment have established that only perchlorate, dioxins/furans, and TCE are chemicals of concern at the PBA.

Pre-existing investigation data (Aerojet & HSI GeoTrans, 2000; Fricke and Carlton, 2005) are extensive and demonstrate that perchlorate contamination in soil is widespread within the PBA. The demonstration was conducted in the vicinity of SS-2 (later converted to well SVS-2), as indicated on Figure 9. Perchlorate concentrations in excess of 100 milligrams per kilogram (mg/kg) were observed near the surface and decreased with depth (Figures 9 through 14). The demonstration was conducted to a depth of 50 feet below ground surface (bgs) and perchlorate concentrations were generally in the single or double digit mg/kg in the vicinity of SS-2 (Figures 13 and 14).

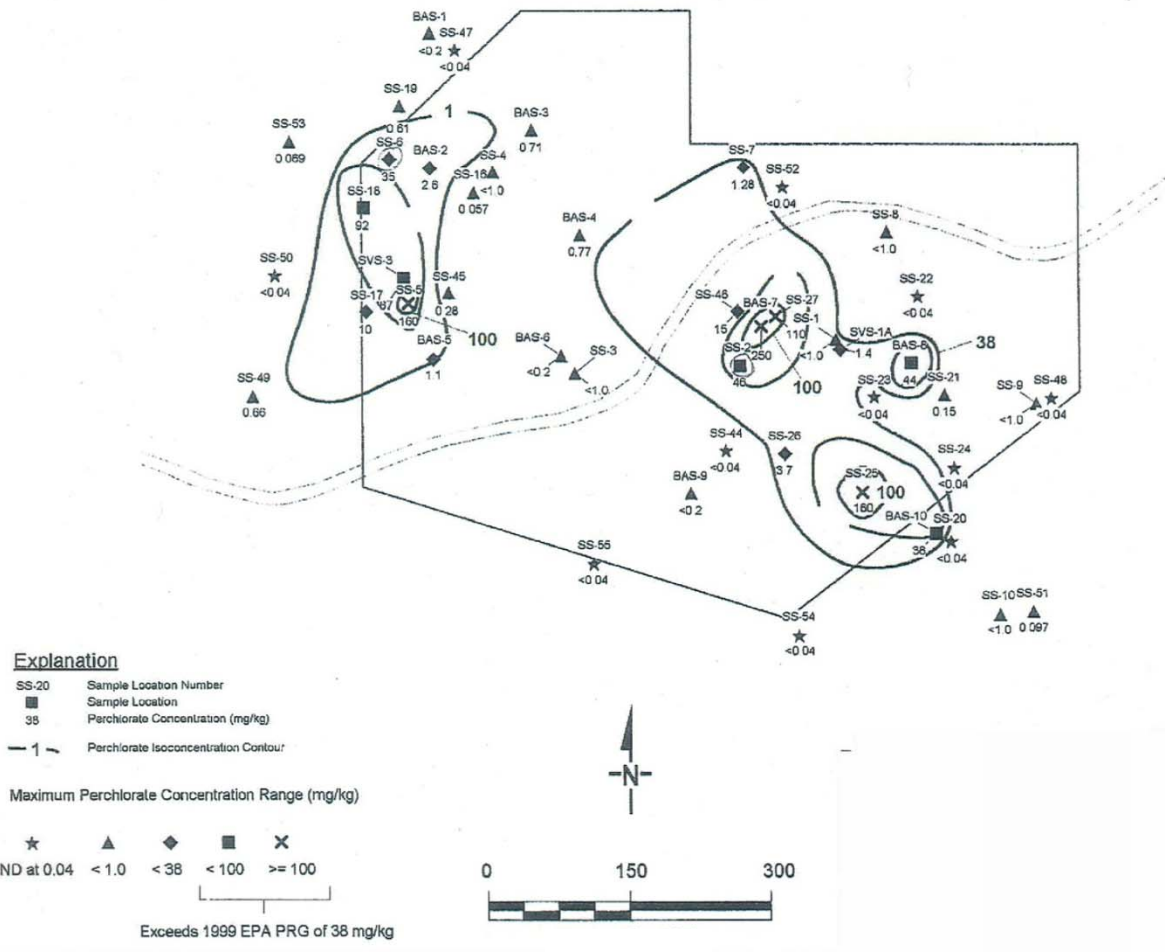

SOURCE: HSI GEOTRANS, 2000, IRCTS-PBA RI, FIGURE 4-2a

Figure 9 – Maximum Perchlorate Concentrations in Soil 0’ to 20’ Below Ground Surface

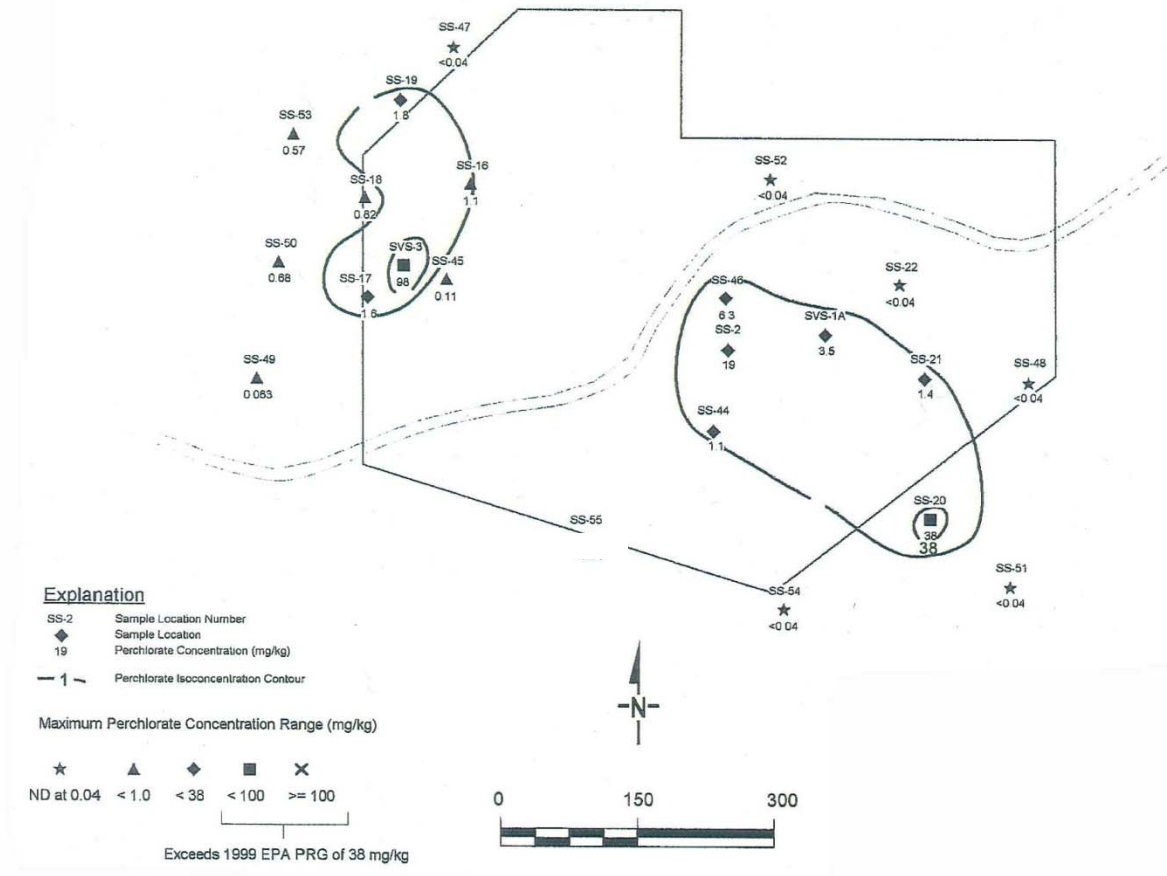

SOURCE: HSI GEOTRANS, 2000, IRCTS-PBA RI, FIGURE 4-2b

Figure 10 – Maximum Perchlorate Concentrations in Soil 21’ to 70’ Below Ground Surface

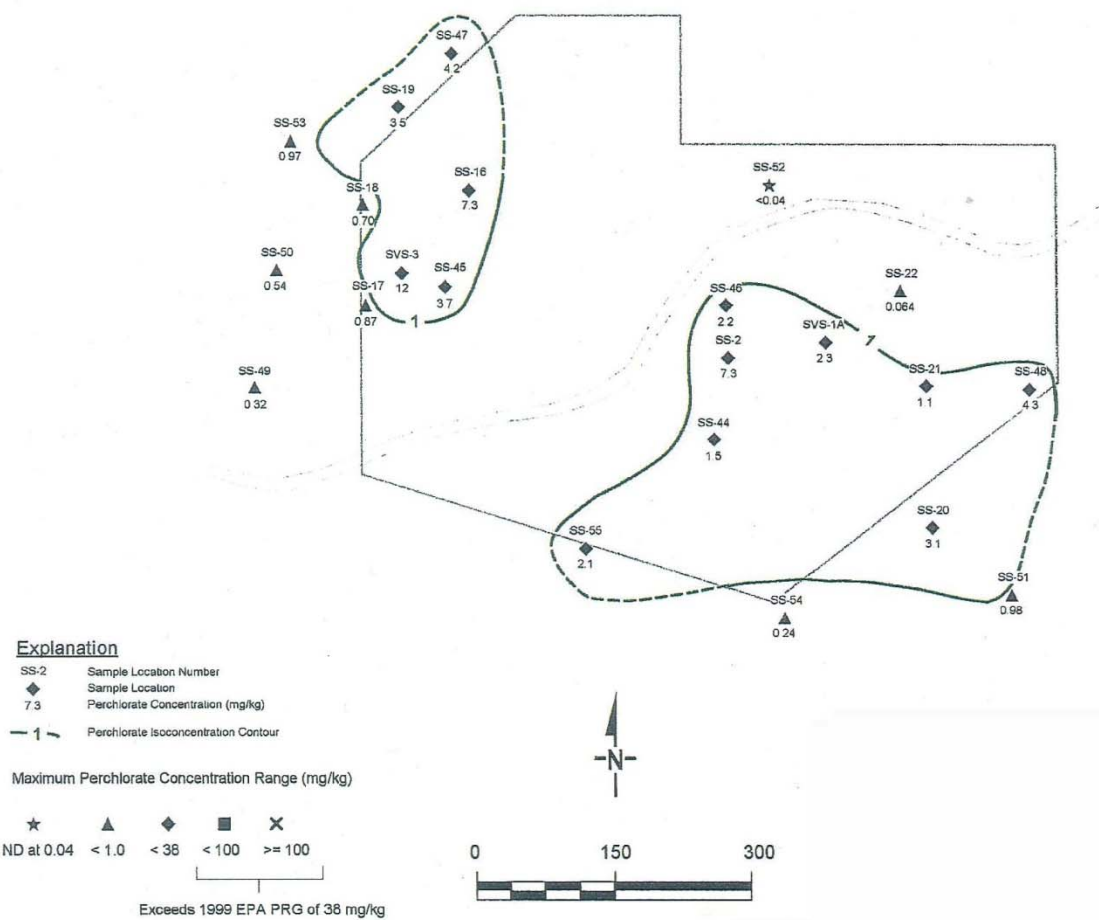

SOURCE: HSI GEOTRANS, 2000, IRCTS-PBA RI, FIGURE 4-2c

Figure 11 – Maximum Perchlorate Concentrations in Soil 71’ to 140’ Below Ground Surface

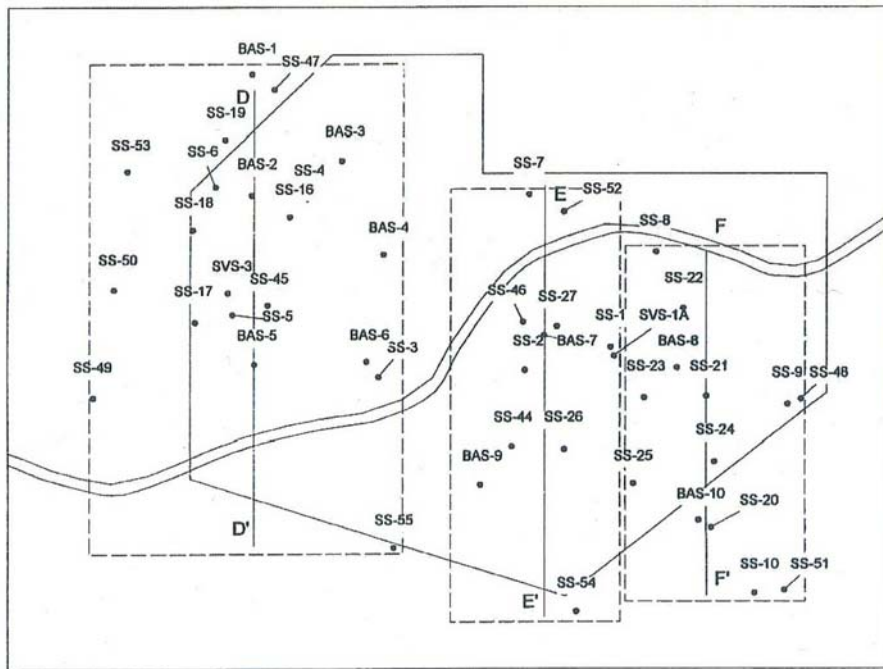
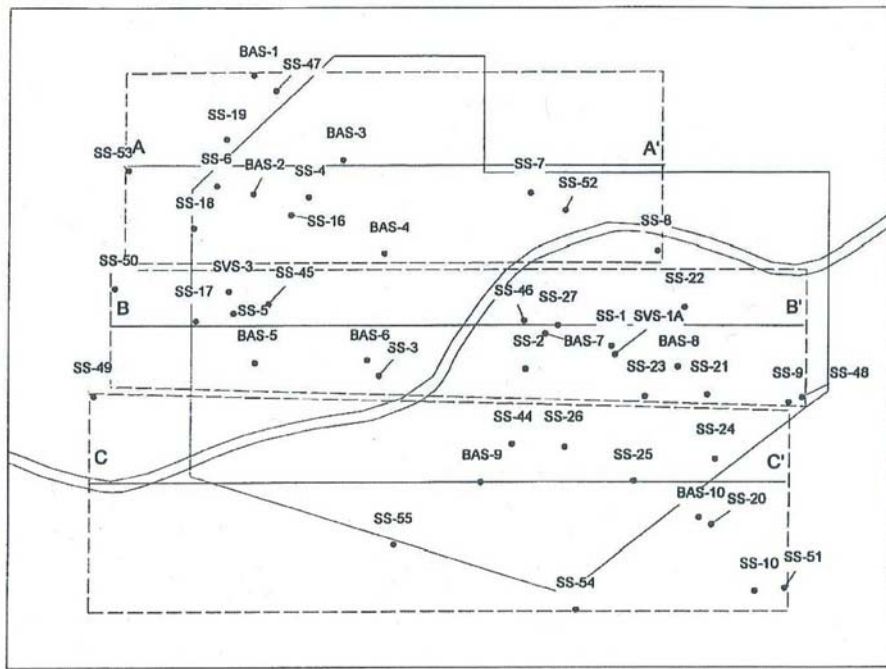

SOURCE: HSI GEOTRANS, 2000, IRCTS-PBA RI, FIGURE 4-3a

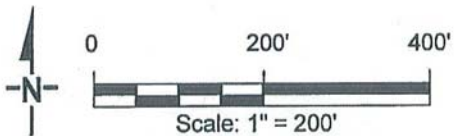
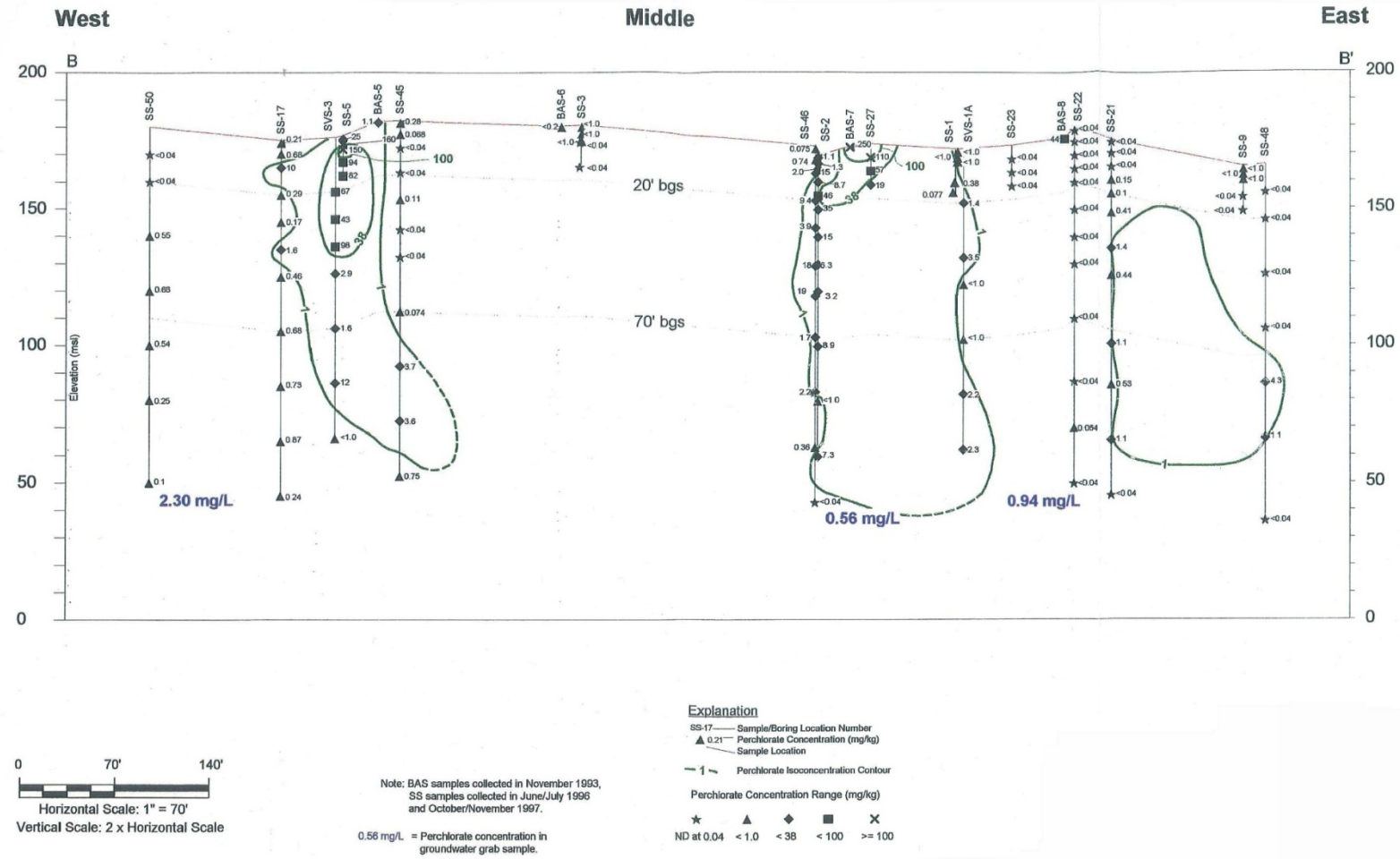
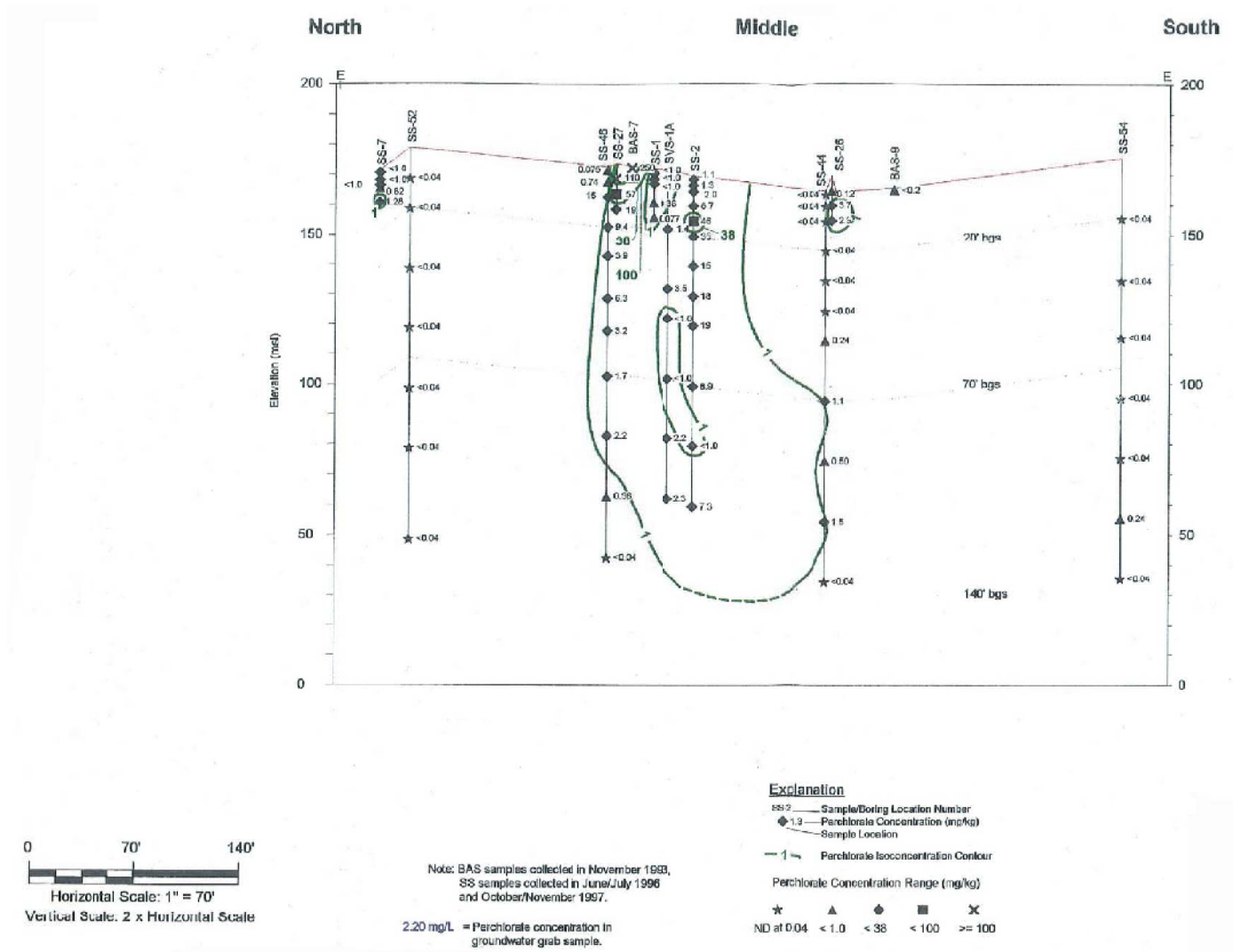

Figure 12 – Perchlorate in Soil Depth Profile Locations



SOURCE: HSI GEOTRANS, 2000, IRCTS-PBA RI, FIGURE 4-3c

Figure 13 – Perchlorate in Soil Depth Profile B-B'



SOURCE: HSI GEOTRANS, 2000, IRCTS-PBA RI, FIGURE 4-3f

Figure 14 – Perchlorate in Soil Depth Profile E-E'

5.0 TEST DESIGN

This section provides the detailed description of the system design and testing conducted during the demonstration.

5.1 Conceptual Experimental Design

The demonstration was conducted in four phases as illustrated in Figure 15.

Phase I comprised treatability studies conducted in the laboratory and at the site. The laboratory treatability study was a microcosm study conducted to identify gaseous electron donors that were capable of promoting perchlorate biodegradation in site soil. The field treatability study involved injection of air into a single well at various flow rates to characterize gas permeability and pneumatic radius of influence in the vadose zone.

Phase II involved tracer tests using a hydrogen/nitrogen mixture and optimization tests using various gas mixtures. The tracer tests were conducted to determine the radius of influence for hydrogen when injected under different conditions. The optimization tests were conducted to identify the combination of variables (e.g., gas composition, injection wells and locations, gas flow rates, pulsing strategy, etc.) that resulted in maximum delivery of electron donor, minimization of oxygen concentrations, and lowest gas use.

Phase III involved continuous injection of a gas mixture comprised of 79 percent nitrogen, 10 percent hydrogen, 10 percent liquefied petroleum gas (LPG), and 1 percent carbon dioxide over a period of about five months. This steady state operation was conducted to generate a vadose zone atmosphere that was supportive of perchlorate biodegradation. Gas and soil samples were collected to verify system operation and quantify perchlorate and nitrate degradation.

Phase IV involved continuous injection of pure LPG to evaluate its potential use as an electron donor. LPG was injected continuously for about three months and gas samples were collected and analyzed periodically. Soil samples were collected and analyzed at the end of this Phase to quantify perchlorate and nitrate biodegradation.

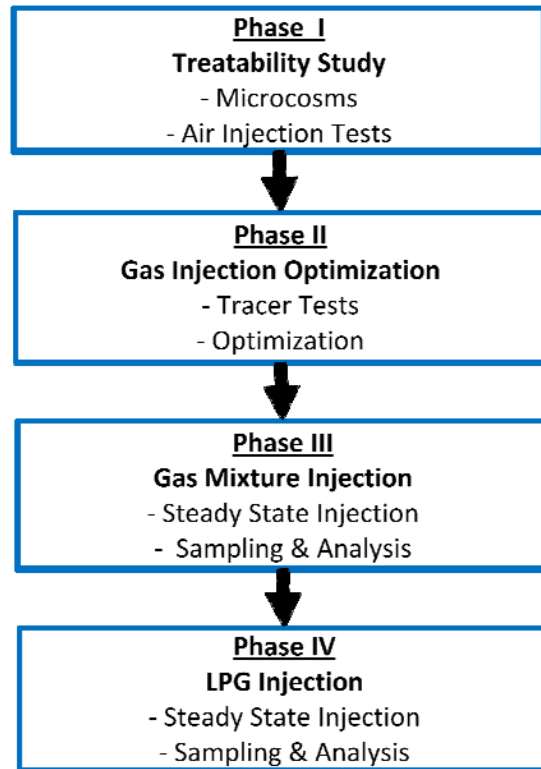

Figure 15 – Demonstration Phases

5.2 Baseline Characterization

This section presents the baseline characterization activities that occurred in 2006. These activities included drilling of two boreholes, collection of soil samples, and installation of one well and one piezometer. The samples were analyzed for soil characteristics and contaminant concentrations and also used for the microcosms in the treatability study.

5.2.1 Drilling, Sample Collection, and Analysis

From July 27, to August 2, 2006, two boreholes were advanced by the Water Development Corporation (WDC) of Woodland, California. Both boreholes were drilled utilizing the sonic drilling method. The injection well (CDM-INJ1) was advanced to a total depth of 70.5 feet below ground surface (bgs) using a 6-inch diameter core barrel and a 10-inch diameter wash-over casing (Figure 16). The piezometer (CDM-P1) was advanced to a total depth of 72 feet bgs using a 4-inch diameter core barrel and a 6-inch diameter wash-over casing. Design details are presented in Section 5.4.

The boreholes were continuously cored to total depth by advancing the core barrel in 10-foot increments. As the core barrel was advanced, a continuous core sample was simultaneously collected inside the core barrel. After each 10-foot increment, the temporary wash-over casing was advanced to depth and the core barrel was tripped from the borehole. The core sample was removed from the core barrel and placed in a plastic core bag. This process was repeated until the borehole was advanced to total depth.

The continuous core was logged using the Unified Soil Classification System (USCS) in accordance to ASTM Standard D2488: Standard Practice for Description and Identification of Soils (Visual-Manual Procedure). The core was logged by a CDM field geologist under the supervision of a State of California, Professional Geologist. The log included a description of the materials encountered during drilling and noting zones impacted of visual contamination. Additionally, the core was screened for volatile organic compounds using a photo-ionization detector (PID) by placing a portion of the core in a zip-lock sealed bag. After approximately five to ten minutes, the zip-lock bag was punctured with a small hole and the tip of the PID was inserted into the bag to assess the head space in the bag for volatile organic compounds. The measurements were recorded on the boring log. The boring logs are presented in Appendix B.

Soil samples were collected from the continuous core and placed in sample containers. As required, some of the samples were placed on ice. Samples were submitted to the CDM laboratory in Bellevue, Washington; Laucks Testing Labs later acquired by Pace Analytical in Seattle, Washington; and The Pennsylvania State University (PSU) in University Park, Pennsylvania under chain-of-custody protocol. Additional details on analytical methods are presented in Section 5.6.

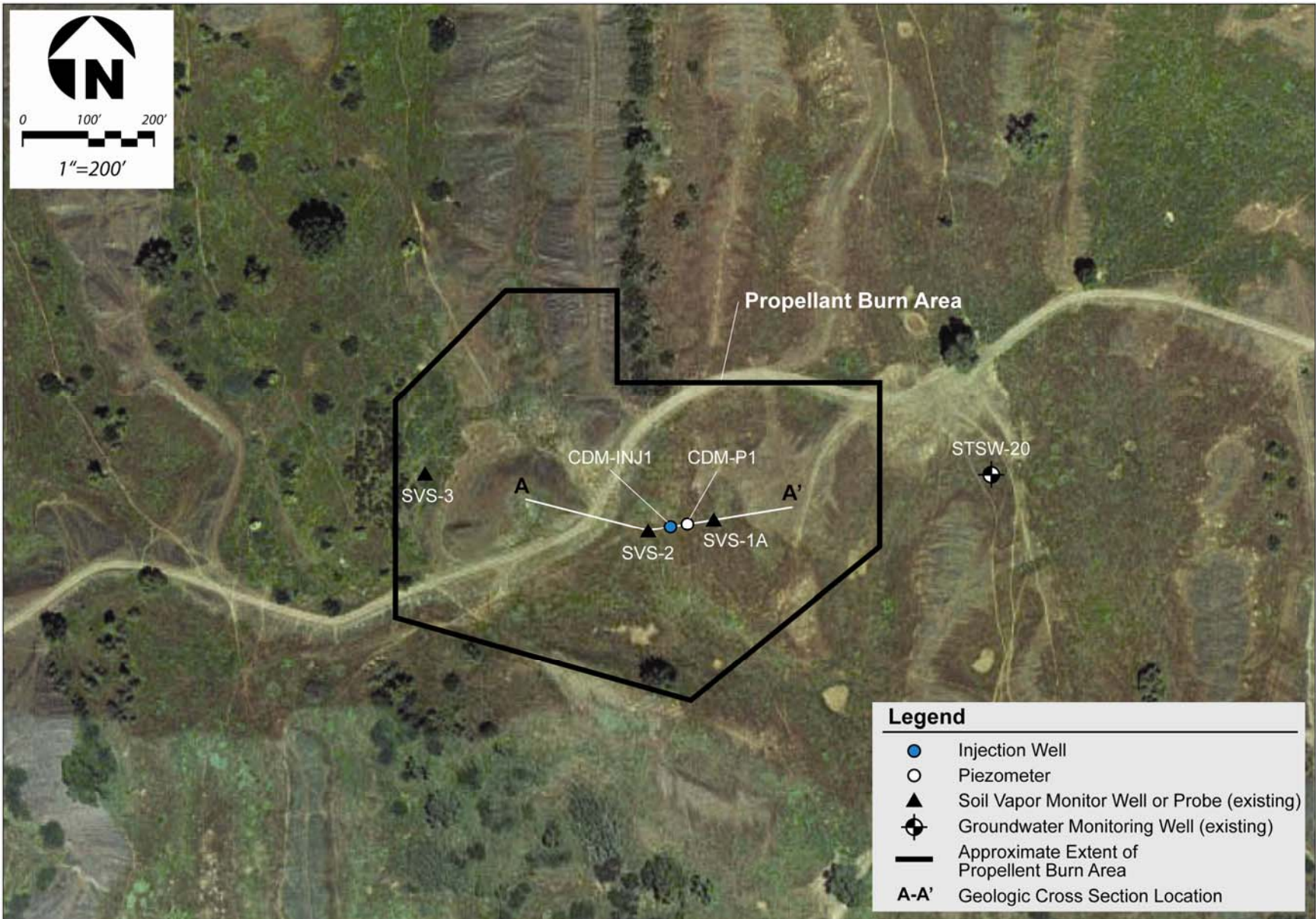

Figure 16 – Locations of Soil Borings/Pilot Test Wells

5.2.2 Baseline Characterization Results

The lithologic conditions encountered during drilling ranged from silt and clay to silty sand and clayey gravel to cobbles. No soil discoloration or odors were observed in the drill cuttings from either boring. All of the PID readings were ND. Groundwater was not encountered during drilling and well construction. A detailed description of the soils encountered in each borehole is presented on the boring logs (Appendix B). Figures 17 and 18 show the grain size distribution for soils encountered during boring completion and Figure 19 shows a lithologic cross-section based on these data and existing data (Aerojet & HSI GeoTrans, 2000). These data indicate that soil is generally coarse-grained and supportive of gas injection with the exception of shallow soil (i.e., 15 ft bgs) in boring CDM-INJ1.

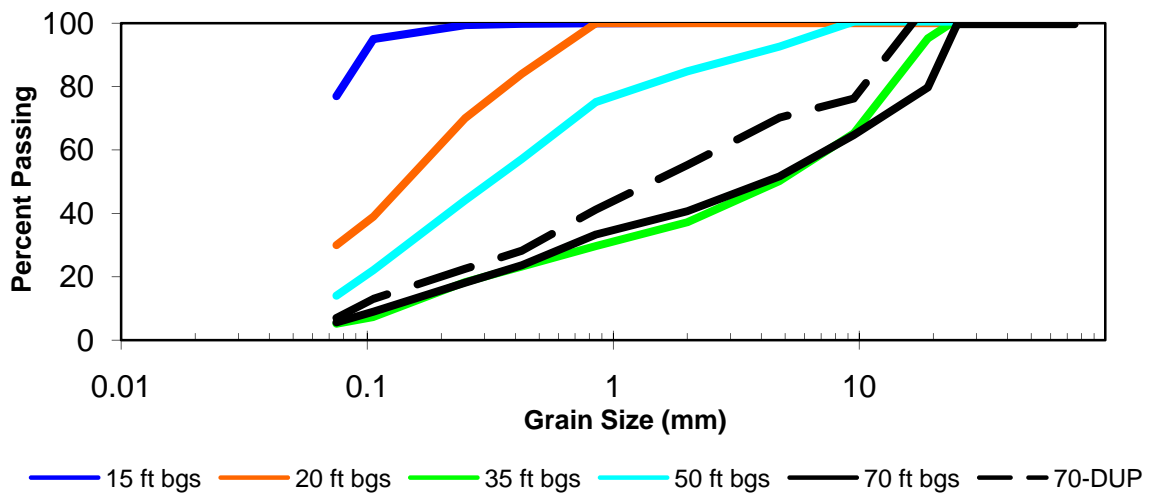

Figure 17 – CDM-INJ1 Grain Size Distribution

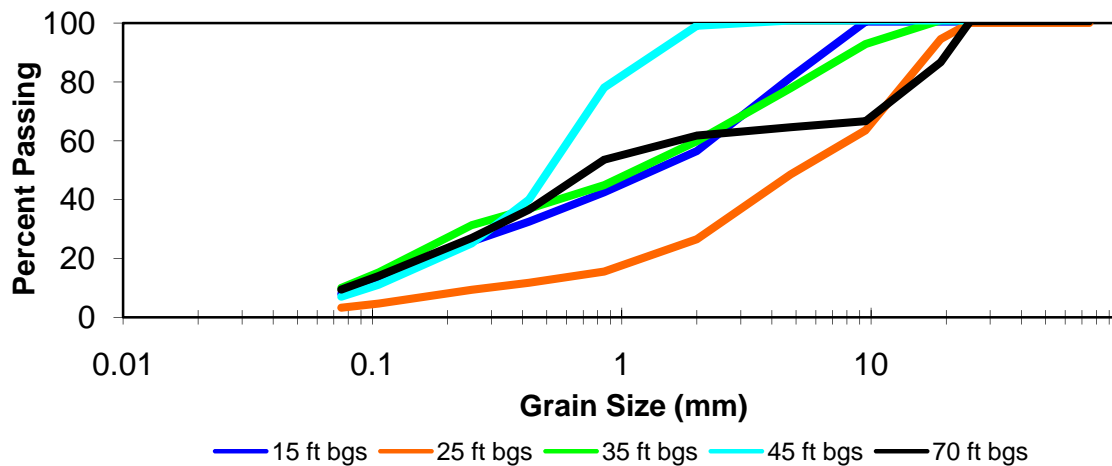

Figure 18 – CDM-P1 Grain Size Distribution

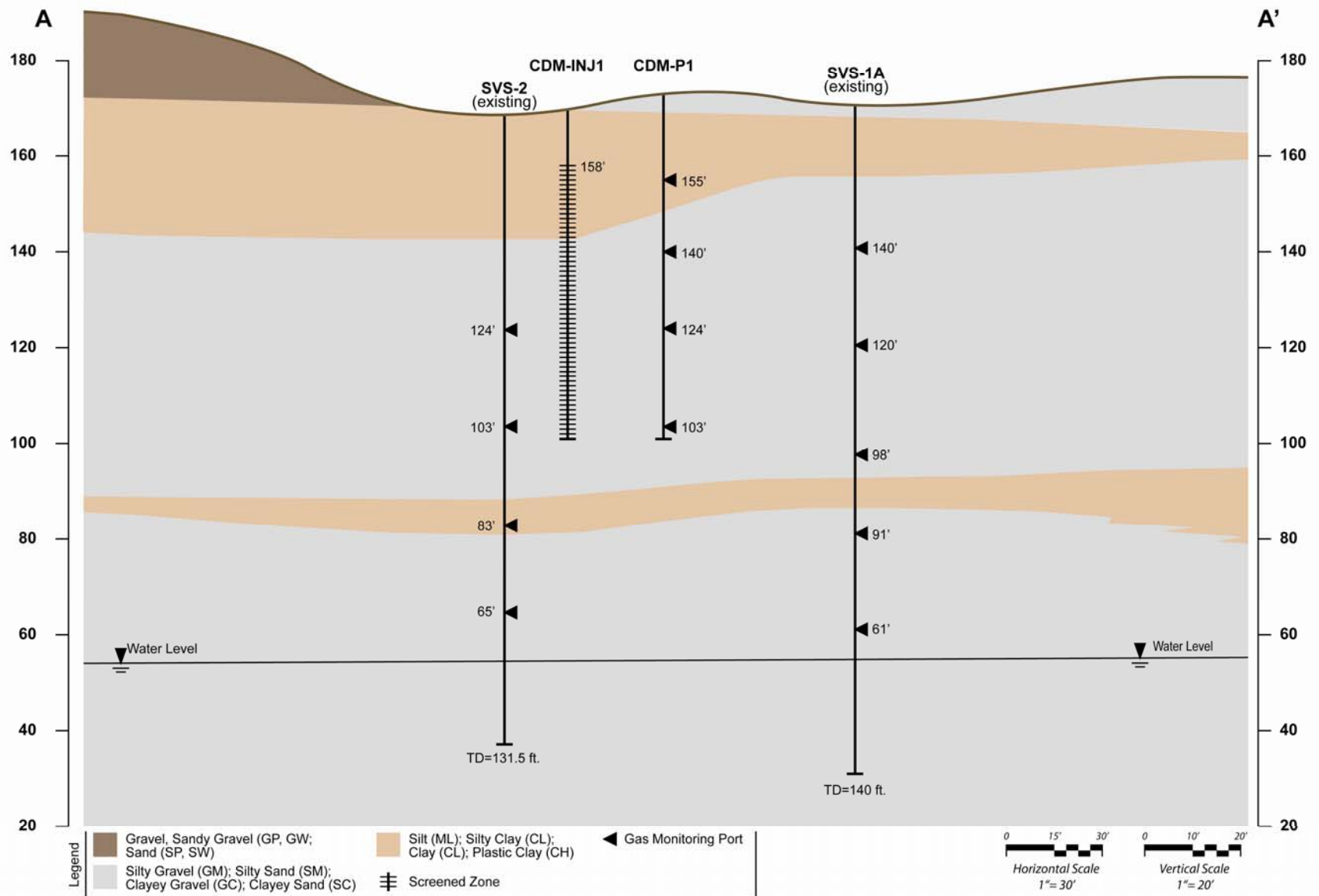

Figure 19 – Generalized Lithologic Cross Section

The analytical results for perchlorate, nitrate/nitrite (i.e., nitrogen as nitrate plus nitrite), and moisture are presented in Figures 20 and 21. For soil from boring CDM-INJ1, the data indicate that nitrate/nitrite concentrations were less than 5 mg-N/kg and perchlorate ranged from 3.7 to 59 mg/kg based on field screening analyses. Perchlorate was present in greater concentrations at shallower depths and was associated with the finer grained soils based on comparison to Figure 21. Greater concentrations of perchlorate were also associated with greater moisture contents. The maximum moisture content in soil from CDM-INJ1 was 34 percent and the minimum moisture content was 6.5 percent.

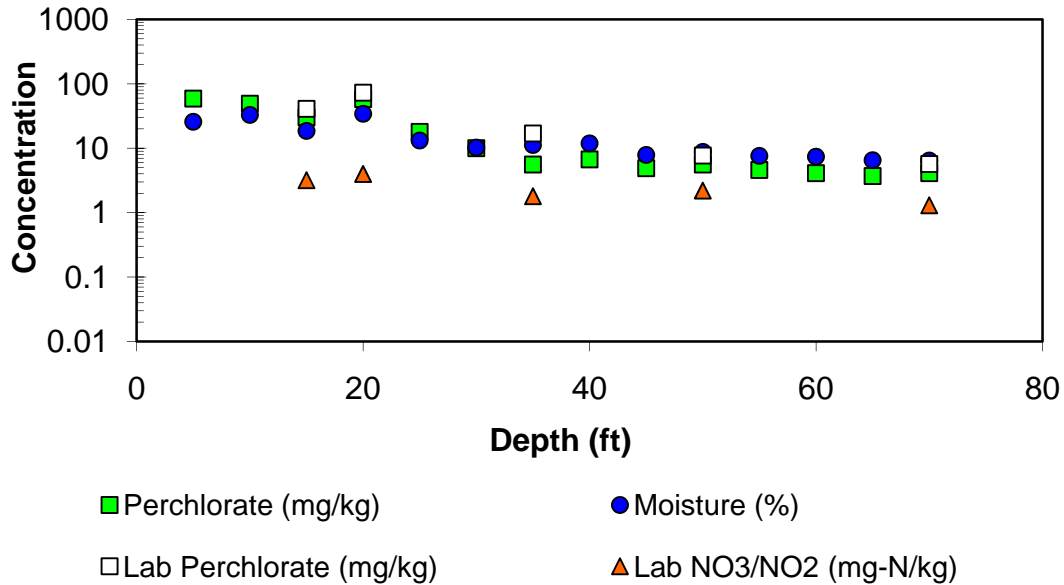

Figure 20 – CDM-INJ1 Contaminant and Moisture Distribution

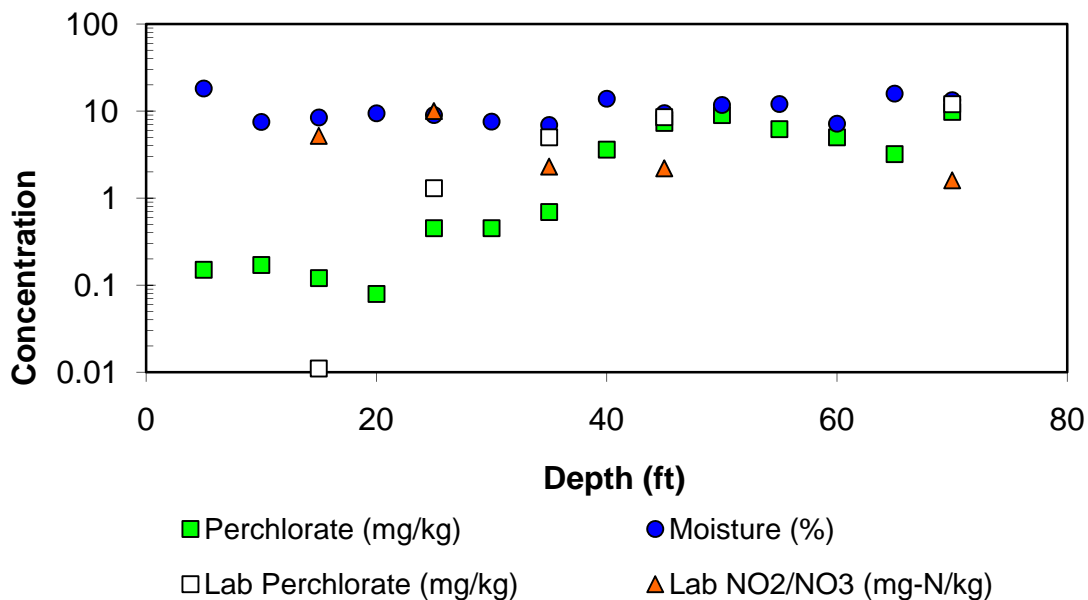

Figure 21 – CDM-P1 Contaminant and Moisture Distribution

For soil from boring CDM-P1, nitrate/nitrite concentrations were similar but perchlorate concentrations were ND at shallow depths and ranged from 0.45 to 9.8 mg/kg at greater depths. Moisture ranged from 6.9 to 18 percent. For soil from both borings, soil moisture ranged from 6.9 to 16 percent in the more permeable soils (i.e., not silt or clay).

Total organic carbon (TOC) concentrations were generally ND or near the limit of detection (0.2 to 0.3 mg/kg) and pH ranged from 6.9 to 8.1. These data and tables for all baseline characterization data are presented in Appendix C.

5.3 Phase I – Treatability Study

This section summarizes the results of the laboratory microcosm and the field air injection studies. Detailed methods and results are presented in Appendix D.

5.3.1 Microcosm Study

Sacrificial batch microcosm tests were used to rapidly assess the ability of gaseous electron donors and various moisture contents to achieve optimal perchlorate remediation in vadose zone soil taken from the site. The electron donor candidates tested were hydrogen, 1-hexene, ethyl acetate, and LPG. Each electron donor was tested at two different concentrations under two different soil moisture contents that were representative of minimum and maximum site moisture contents at the site. Perchlorate reduction did not occur in low moisture (7 percent) microcosms after an incubation time of 125 to 187 days, and all bottles except ethyl acetate achieved complete or partial perchlorate reduction in high moisture (16 percent) bottles (Figure 22). Perchlorate reduction was observed in the negative control. However, this reduction was attributable to an experimental artifact where hydrogen was produced when the microcosm bottles were initially left on the laboratory bench in the light. This artifact is explained in detail in Appendix D.

Results from these microcosm tests indicate that hydrogen was an effective electron donor for perchlorate biodegradation in site vadose zone soil, achieving complete perchlorate degradation within 35 to 42 days. LPG may have promoted complete perchlorate reduction at the high LPG dose and 1-hexene may have promoted partial perchlorate reduction at both doses; however, when compared to hydrogen, these donors had more significant lag periods of 21 to 49 days, respectively. Additionally, the observation of perchlorate reduction in the negative does not allow definitive conclusions regarding the effects of these electron donors on perchlorate reduction.

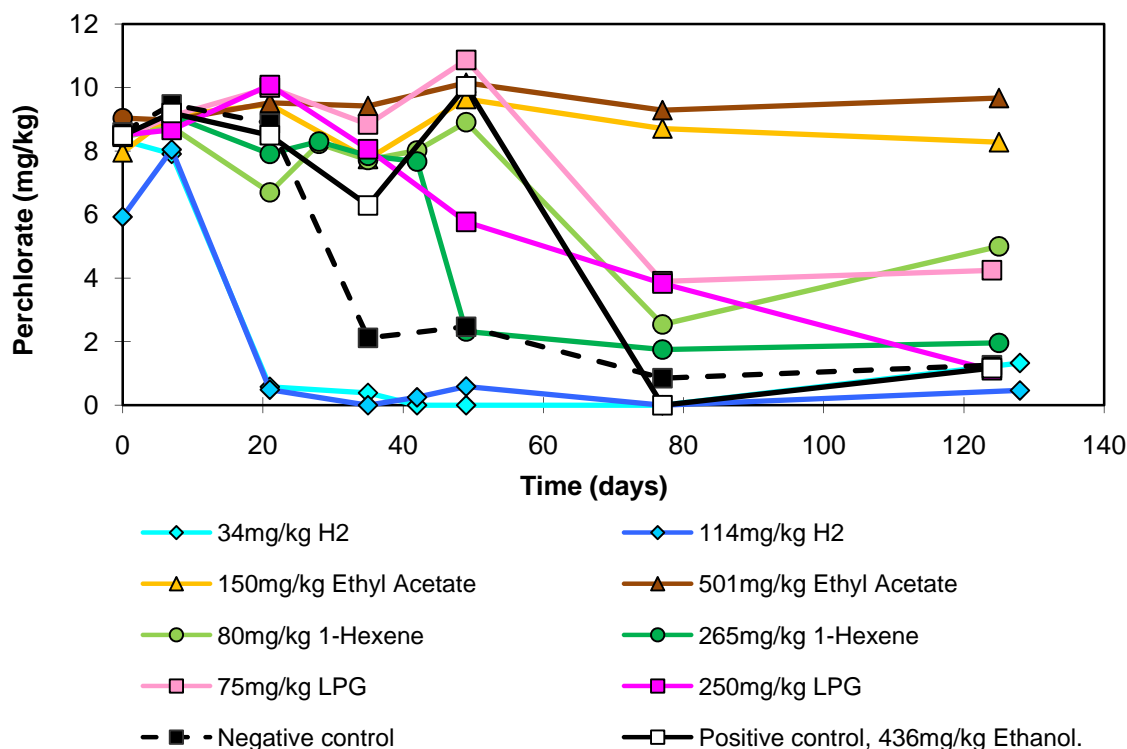

Figure 22 – Microcosm Study Results at the High Moisture Condition

5.3.2 Air Injection Test

An air injection test was conducted at the PBA site using the injection well CDM-INJ1 and piezometer CDM-P1 in combination with the two existing wells at the site (SVS1A and SVS2). The objectives of the air injection test were to:

- Estimate the corresponding backpressures for various gas flow rates; and
- Estimate the pneumatic zone of influence of gas injection.

The data show minimal pressure at the injection well (5 inches water column [in. w.c.] or less) and a positive effect from air injection on the piezometers located up to 84 feet from the injection well (Figure 23). The average pneumatic permeability (k) based on these data was calculated to be $5.6 \times 10^{-4} \pm 0.9 \times 10^{-4} \text{ cm}^2$ at 120 ft above mean sea level (amsl) based on the observed data (Figure 24). This permeability is high and typically associated with unconsolidated gravels. Because of this high permeability, the radius of pneumatic influence at the maximum flow rate of 420 cubic feet per minute (cfm) was determined to be at least 84 ft. Pneumatic effects were observed at a distance of 34 ft at the lowest flow rate tested – 21 cfm (Figure 25). Pneumatic effects were observed at elevations down to about 50 ft bgs (i.e., 120 ft amsl). Based on this result, the remaining injection wells and piezometers were installed only to a depth of 50 ft bgs rather than 70 ft bgs.

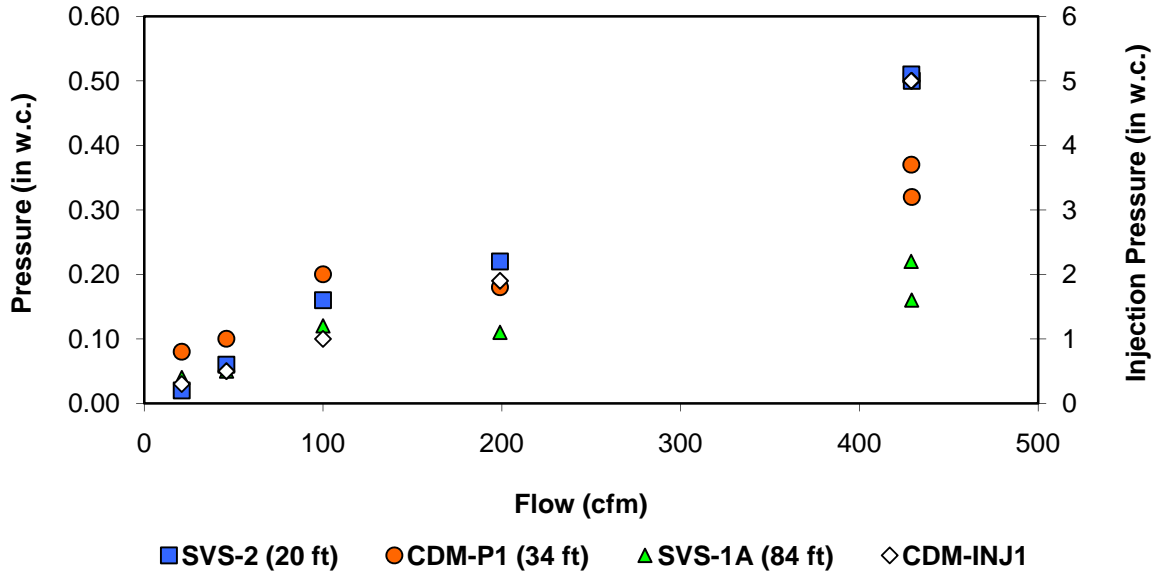

Figure 23 – Effect of Air Injection Flow on Pressure at 120 ft amsl

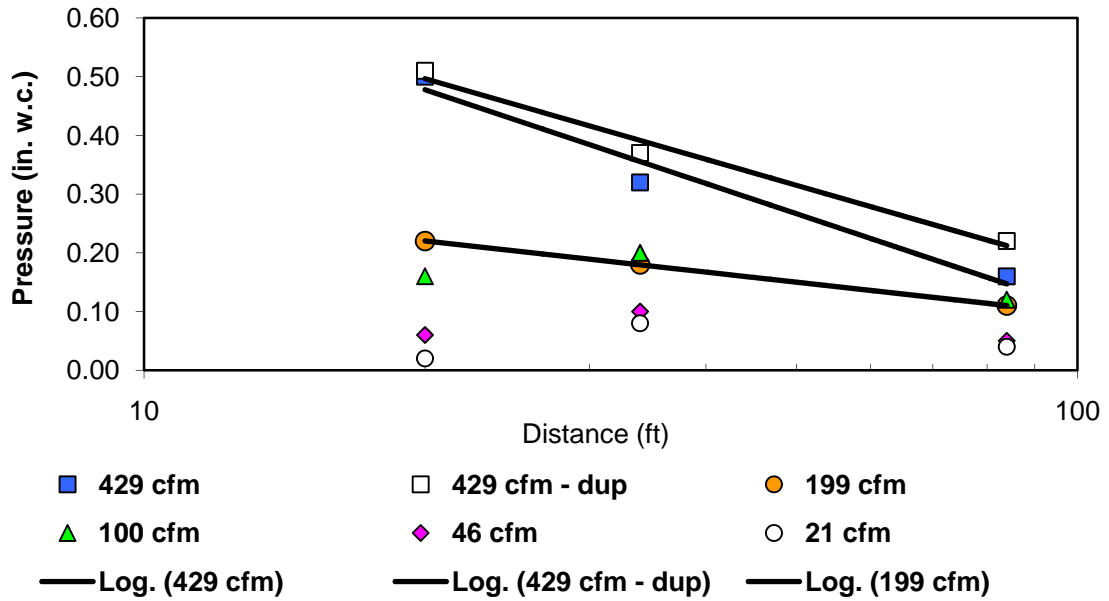

Figure 24 – Relationship between Distance from Injection Well INJ1 and Piezometer Pressure at 120 ft amsl

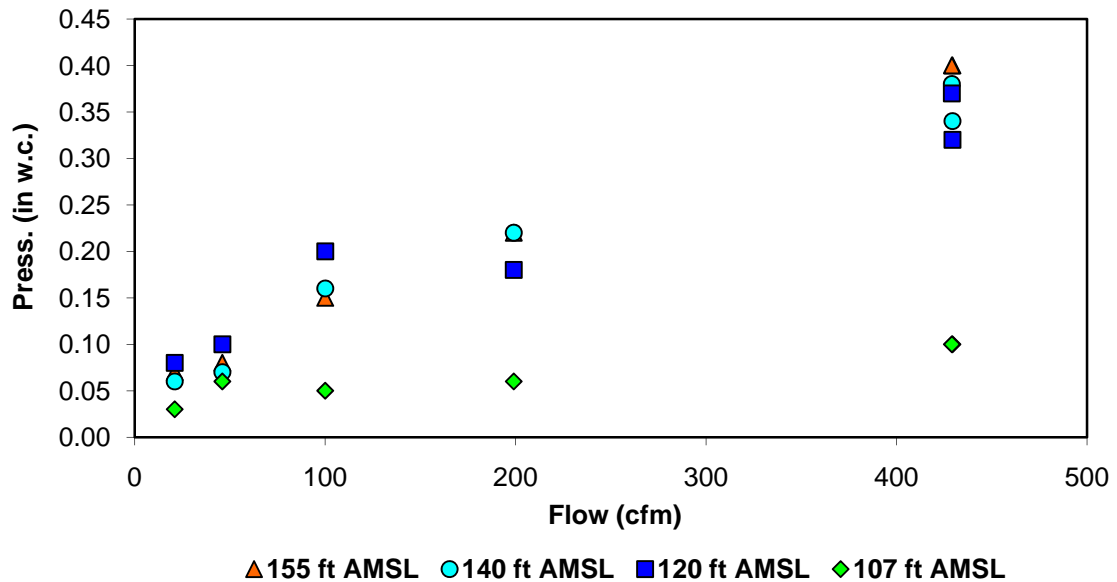

Figure 25 – Effect of Air Flow on Pressure at Piezometer P1

5.4 Design and Layout of Technology Components

This section presents the design and construction attributes of the wells, piezometers, and process equipment used for the demonstration.

5.4.1 Wells and Piezometers

A total of three injection wells and ten piezometers were installed for the demonstration (Figure 26). The original design concept was based on three injection wells arranged in an equilateral triangle with an inter-well spacing of 20 ft. Two transects of piezometers were installed radiating from well INJ2. One transect in a general east-west orientation comprised piezometers P4 through P1 and SVS-1A. A second transect in a general north-south orientation comprised piezometers SVS-2 and P5 through P8. As described in Section 5.5, Phase III and IV gas injections were ultimately conducted using piezometer P4 rather than any of the “injection” wells. The distances of the wells and piezometers from well INJ2 and piezometer P4 are listed in Table 4.

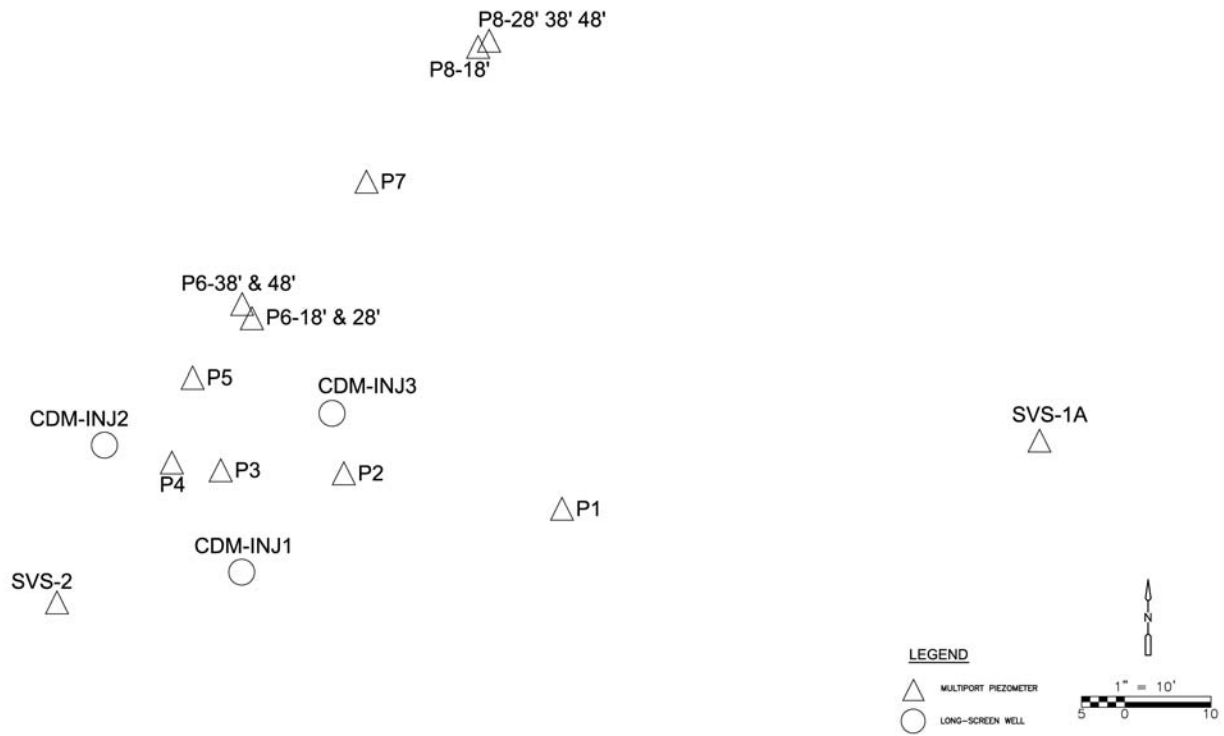

Figure 26 – Piezometer and Well Locations

Table 4 – Well and Piezometer Distances

ID	Distance from INJ2 (ft)	Distance from P4 (ft)
INJ1	21.7	14.7
INJ2	0.0	8.2
INJ3	26.7	19.6
P1	53.6	45.6
P2	28.0	18.6
P3	13.9	5.33
P4	8.2	0.0
P5	12.6	9.4
P6	22.4	18.1
P7	42.7	36.7
P8	63.7	56.1
SVS-1A	134	125
SVE-2	19.5	21.0

Two of the piezometers (SVE-1A and SVE-2) were constructed prior to this project and construction details are presented in Table 5. One injection well (INJ1) and one piezometer (P1) were installed in 2006 as described in Section 5.2.1. Injection well INJ1 was constructed with 6-inch diameter schedule 40 PVC from ground surface to 10 feet bgs and slotted 6-inch diameter schedule 40 PVC (0.020-inch slot size) from 10 to 70 feet bgs. Annular materials include a filter pack (No. 3 Monterey Sand) from 8 to 70.5 feet bgs, a bentonite chip seal from 6 to 8 feet bgs, and a cement grout surface seal from ground surface to 6 feet bgs. Annular materials were installed by pouring the materials into the annular space between the well casing and the wash-over casing. Depths were tagged periodically to ensure the materials were installed to the specified depths. Piezometer P1 was a nested piezometer with four discrete sampling depths (Table 5). The piezometer consisted of 0.25-inch diameter stainless steel vapor probes connected to 0.25-inch diameter polyethylene tubing. The probes were installed by securing the probe and tubing to a 1-inch diameter PVC pipe. The PVC pipe was then inserted into the wash-over casing. Annular materials were then poured into the annular space between the wash-over casing and the tubing. Depths were tagged periodically to ensure the materials were installed to the specified depths. The injection well and piezometer were completed with flush-mounted well boxes. Boring logs and as-built well diagrams are presented in Appendix B.

Table 5 – Summary of Well Construction Details

Well ID	Well Type	Construction Date	Total Depth (feet bgs)	Casing/Tubing Diameter (inches)	Screen Intervals (feet bgs)
INJ1	Injection well	7/31/2006	70.5	6	10 - 70
INJ2	Injection well	10/26/2007	50	4	10 - 50
INJ3	Injection well	10/17/2007	50	4	10 - 50
P1	Piezometer	7/27/2006	72	0.25	18-18.5, 33-33.5, 48-48.5, 68-68.5
P2	Piezometer	10/25/2007	52	0.25	18-18.5, 28-28.5, 38-38.5, 48-48.5
P3	Piezometer	10/23/2007	52	0.25	18-18.5, 28-28.5, 38-38.5, 48-48.5
P4	Piezometer	10/29/2007	51.5	0.25	18-18.5, 28-28.5, 38-38.5, 48-48.5
P5	Piezometer	10/24/2007	51.5	0.25	18-18.5, 28-28.5, 38-38.5, 48-48.5
P6	Piezometer	10/22/2007	50	0.25	38-38.5, 48-48.5
P6A	Piezometer	10/24/2007	30.5	0.25	18-18.5, 28-28.5
P7	Piezometer	10/16/2007	62	0.25	18-18.5, 28-28.5, 38-38.5, 48-48.5
P8	Piezometer	10/11/2007-10/12/2007	50	0.25	28-28.5, 37.5-38, 48-48.5
P8A	Piezometer	10/15/2007	20.5	0.25	18-18.5
SVE-1A	Piezometer	8/26/1996	140	0.25	30-30.5, 50-50.5, 73-73.5, 90-90.5, 110-110.5
SVE-2	Piezometer	7/1/1996	132	0.25	45-45.5, 65-65.5, 86-86.5, 104-104.5

The remaining two injection wells (INJ2 and INJ3) and seven piezometers (P2 through P8), were installed between October 11 and October 29, 2007. The injection wells and piezometers were installed by WDC under CDM supervision using the sonic drilling method. The boreholes were continuously cored from ground surface to the total depth of the borehole using a 4.5-inch O.D. core barrel. After the core samples were collected from the borehole, a wash-over casing was installed to the total depth of the borehole. The wells and piezometers were then constructed inside the wash-over casing. The injection wells were installed using an 8-inch diameter wash-over casing. The piezometers were installed using a 6-inch diameter wash-over casing.

Injection wells INJ2 and INJ3 were constructed with 4-inch diameter schedule 40 PVC from ground surface to 10 feet bgs and slotted 4-inch diameter schedule 40 PVC (0.020-inch slot size) from 10 to 50 feet bgs. Annular materials include a filter pack (No. 3 Monterey Sand) from 8 to 50 feet bgs, a bentonite chip seal from 5 to 8 feet bgs, and a cement grout surface seal from ground surface to 5 feet bgs. Annular materials were installed by pouring the materials into the annular space between the well casing and the wash-over casing. Depths were tagged periodically to ensure the materials were installed to the specified depths. Boring logs and as-built well diagrams are presented in Appendix B. A generalized well design is depicted in Figure 27.

Piezometers P2 through P8 were nested piezometers with various sampling depths (Table 5) and were constructed similarly to P1. A generalized piezometer design is depicted in Figure 28). Piezometer P6 was completed in two separate boreholes. While tripping the wash-over casing out of the borehole during well construction, a suspected borehole collapse occurred, preventing proper installation of the annular materials. The upper two sampling points for P6 at 18-18.5 and 28 to 28.5 feet bgs were completed as P6A in a separate borehole located approximately two feet southeast of P6. Piezometer P8 was also completed in two separate boreholes. During construction of P8, the tubing to the sampling probe for the 18-18.5 foot sampling interval was pulled out of the borehole while tripping out the wash-over casing. This sampling point was completed as P8A in a separate borehole located approximately two feet southwest of P8.



It should also be noted that during the initial startup and trouble-shooting phase, it was discovered that gas sampling was not possible from the uppermost sampling zone in P7 (from 18-18.5 feet bgs). It is unclear whether this is a result of faulty well construction or a function of the geology (i.e., the soil may be too compacted in this location to collect soil gas samples).

5.4.2 Process Equipment

Figure 29 is a process and instrumentation diagram (P&ID) for the gaseous electron donor injection system and Table 6 lists gas supply equipment and general specifications. Figures 30 and 31 are photographs of the gas supply equipment and gas flow control panel, respectively. The gas injection system was designed to allow injection of a mixture of nitrogen, hydrogen, propane (i.e., LPG), and carbon dioxide. Provisions for injection of helium as a tracer were also included. The gas injection system was designed to be operated without any electrical requirements because of the remoteness of the site. The liquid nitrogen and LPG systems were vaporized using vendor-supplied equipment prior to injection. Each gas flow was controlled using manual pressure regulators and flow control valves along with rotameters to measure flow

and gauges to monitor pressure. The gases were mixed prior to distribution to the injection wells. All above-ground piping was carbon steel.

LEGEND

-  CEMENT BENTONITE GROUT SEAL
-  BENTONITE CHIP SEAL
-  NO. 3 MONTEREY SAND

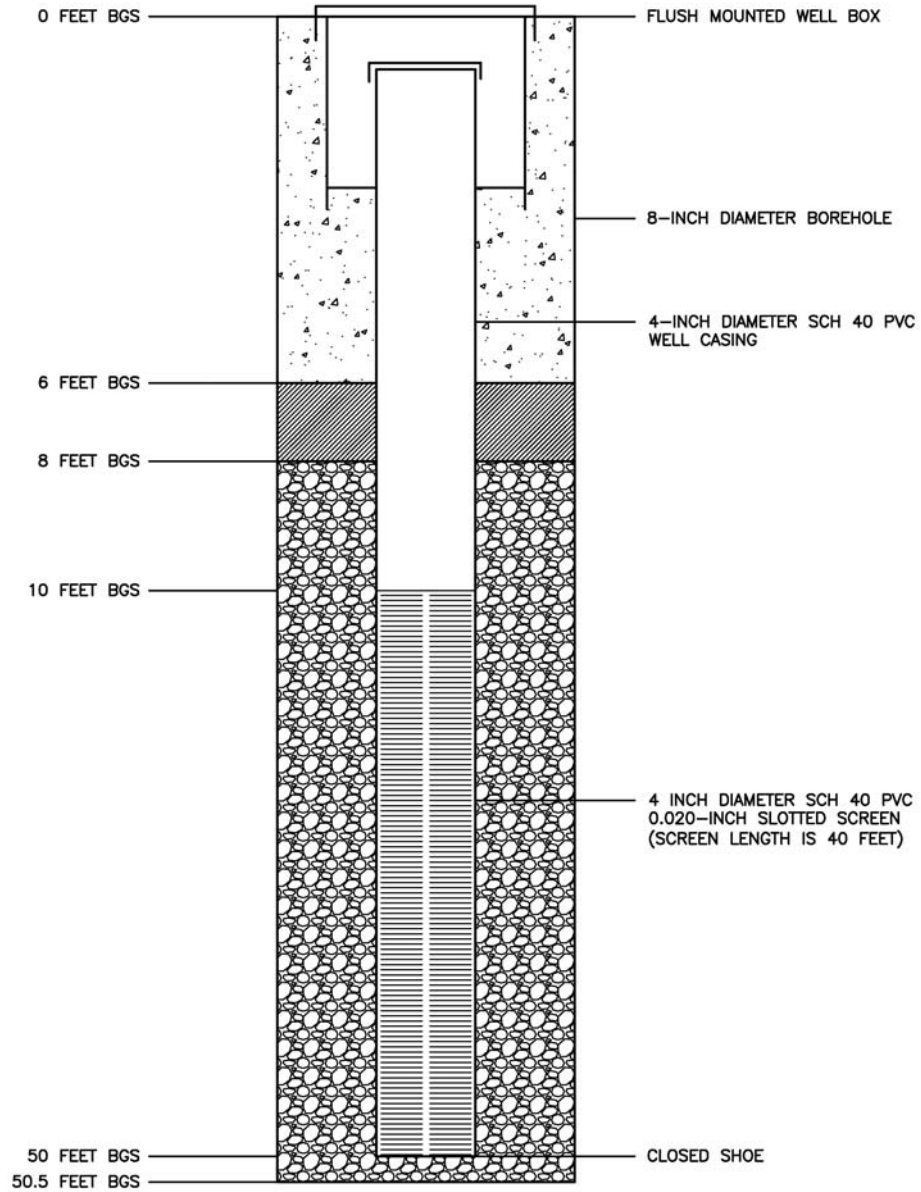

NOT TO SCALE

Figure 27 – Injection Well Design

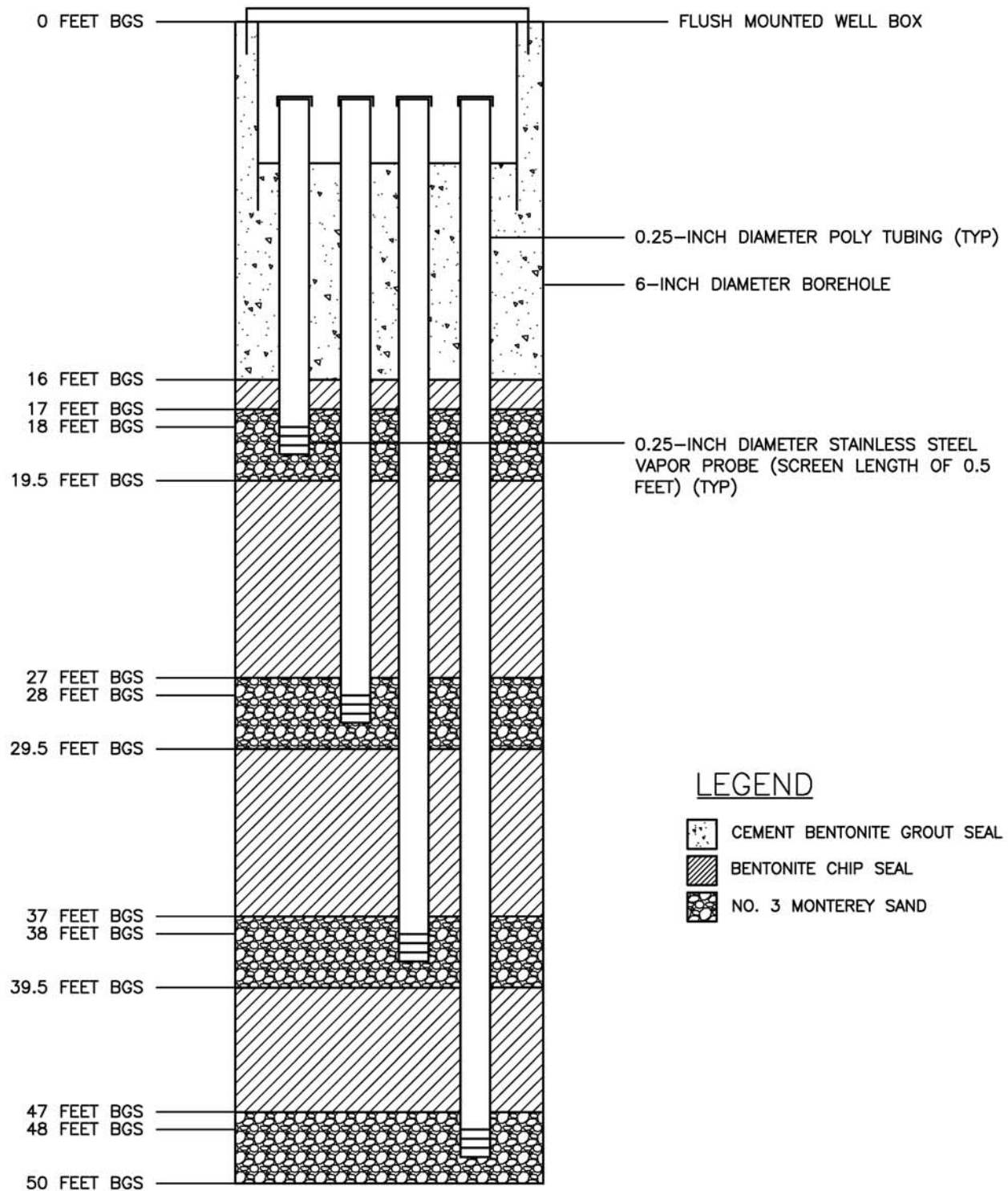

NOT TO SCALE

Figure 28 – Piezometer Design

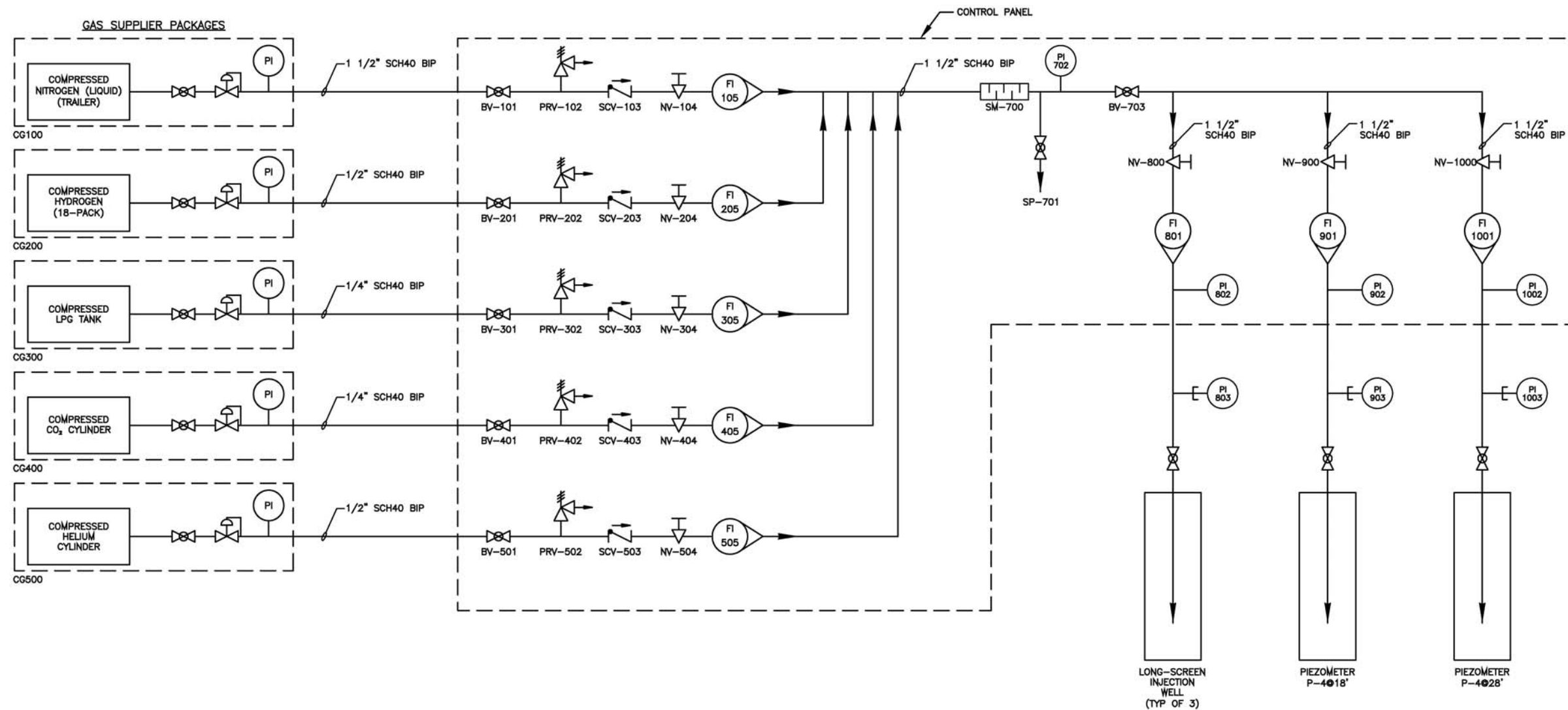

NOTE:

ALL FLAMMABLE TANKS/LINE SHALL BE ELECTRICALLY GROUNDING.

LEGEND

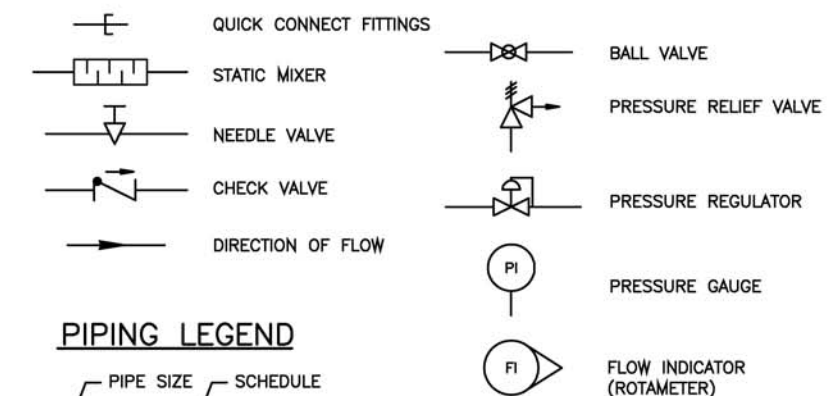

PIPING LEGEND

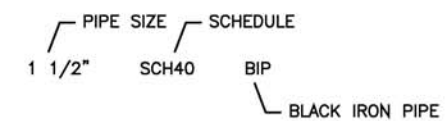

Figure 29 – Process and Instrumentation Diagram

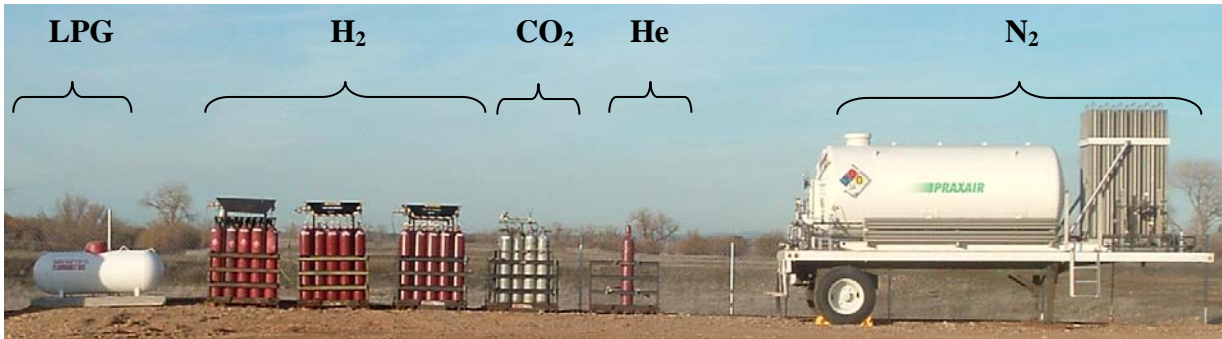

Figure 30 – Gas Supply for the Demonstration



Figure 31 – Gas Supply Control Panel

Table 6 – Gas Supply Equipment

Tag	Description	Specifications
CG-100	Liquid nitrogen	Trailer, 150,000 cubic feet gas capacity
CG-200	Compressed hydrogen	Three 18-packs of K cylinders; 3,600 cubic feet gas capacity each 18-pack
CG-300	Liquefied petroleum gas, odorized	120 gallon, 3,500 cubic feet gas capacity
CG-400	Compressed carbon dioxide	18-pack K cylinders , 4,800 cubic feet gas capacity
CG-500	Compressed helium	T Cylinder, 290 cubic feet gas capacity

5.5 Field Testing

The treatability study and field demonstration comprised four phases as described in Section 5.1 (Figure 13). Phase I comprised the treatability study and was previously described in Section 5.3. Phases II through IV were conducted over a period of 10.5 months as illustrated in Figure 32. Detailed descriptions of each of the phases are provided below.

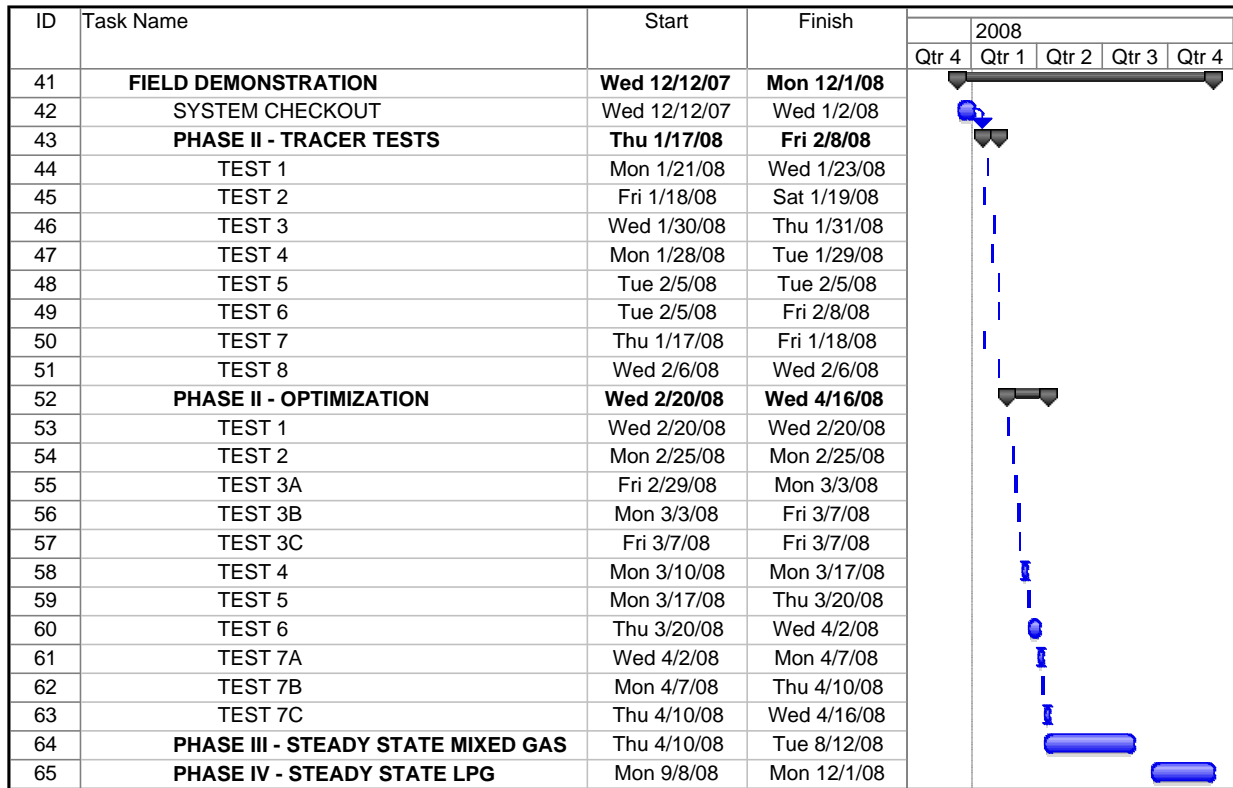

Figure 32 – Demonstration Schedule

5.5.1 Phase II – Gas Injection Optimization

Phase II comprised tracer tests and optimization tests. The tracer tests were conducted to characterize gas transport in the vadose zone. The optimization tests were conducted to identify the most cost-effective method of delivering a 79-10-10-1 percent mixture of nitrogen, hydrogen, LPG, and carbon dioxide, respectively, to the vadose zone and minimizing oxygen intrusion.

Tracer Tests

The purpose of the tracer tests was to verify well and piezometer performance and to characterize gas transport in the vadose zone. The original approach outlined in the Technology Demonstration Plan was to inject varying flow rates of nitrogen into one or more injection wells and use helium as a tracer. During field testing the helium meter (i.e., Matheson 8067-IS Leak Detector) was found to be unreliable. Therefore, hydrogen was used as a tracer instead. Unlike helium, hydrogen is not a conservative tracer because it is capable of being oxidized to water by autotrophic and other hydrogen-oxidizing bacteria. While the rates of biological hydrogen consumption were likely to be small relative to the rate of gas transport for these tracer tests, the results of these tracer tests are representative of hydrogen transport and degradation.

A mixture of nitrogen and hydrogen was injected at different total flow rates into various injection wells as outlined in Table 7. Pure nitrogen was injected into the well(s) in between each test to flush hydrogen out of the vadose zone in preparation for the next test. Thus each tracer test was a “step test” where the concentration of hydrogen in each piezometer was monitored during the test to characterize transport of hydrogen through the vadose zone. Well INJ2 was selected for the individual test because of its placement relative to the piezometers. The flow rates to individual wells during tests 6 through 8 were equivalent and thus a third of the total flow rates listed in Table 7.

Table 7 – Phase II Tracer Test Conditions

Test	Target Flow Rate per Well	Target Total Flow Rate	Measured Total Flow Rate	Duration	Hydrogen Concentration	Injection Wells		
	(cfm)	(cfm)	(cfm)			(h)	(percent)	INJ1
1	10	10	9.6	50	6.5		X	
2	20	20	19	31	7.4		X	
3	30	30	27	27	4.1		X	
4	60	60	63	19	6.3		X	
5	90	90	87	6.4	3.6		X	
6	10	30	29	20	8.0	X	X	X
7	20	60	59	6.9	5.0	X	X	X
8	30	90	84	7.1	4.6	X	X	X

The experimental design involved injection of gas into one well (i.e., INJ2) and variation of the total flow rate from 10 to 90 cfm in tests 1 through 5. Tests 6 through 8 involved injection of gas into all three wells and the flow rates were selected to allow comparison with tests 1 through 3

and tests 3 through 5. The comparison of tests 6 through 8 with tests 1 through 3 was based on equal flow rates per well (i.e., 10, 20, and 30 cfm). The comparison with tests 3 through 5 was based on equal total flow rate (i.e., 30, 60, and 90 cfm).

Monitoring during the test involved measurement of pressures at each piezometer and collection of gas samples for analysis. The gas samples were analyzed for hydrogen using a field instrument. The details of monitoring, sampling, and analysis are presented in Section 5.6.

Optimization Tests

The purpose of the optimization tests was to characterize electron donor transport and oxygen depletion and rebound in the vadose zone during various injection strategies. These tests were then used to select the optimal injection strategy. The optimal injection strategy was considered to be one that maximizes electron donor distribution, minimizes oxygen concentrations in the vadose zone, and minimizes gas use.

Gas flow rate, injection pulse duration, gas injection location(s), and gas composition were varied during the optimization tests (Table 8). The original experimental design as outlined in the Technology Demonstration Plan was based on pulsing gas injection and varying the total flow rate and the pulse duration to determine the optimal pulsing strategy. Tests 1 and 2 were based on this approach. Both of these tests involved injection of a total of 21,600 cubic feet of gas into the vadose zone. As described in Section 5.7.2, significant and rapid oxygen intrusion into the vadose zone was observed following both of these tests. Therefore, the original experimental approach was modified to identify an injection strategy that minimized oxygen intrusion. The test conditions for each test were selected based on observed results of the previous tests. Tests 3 through 5 were based on varying the number of wells, flow rate, pulse duration, gas composition, and use of staged pulsing and continuous gas injection. In addition, the gas composition was varied. None of these tests resulted in acceptable oxygen concentrations in the vadose zone. It was hypothesized that the permeable lithology (see Section 5.3.2) in combination with the long well screens (i.e., 40 to 60 feet) prevented use of the existing wells and that injection into the piezometers may prove effective. Tests 6 and 7 evaluated this hypothesis which led to an optimal gas injection strategy that minimized oxygen intrusion into the vadose zone.

Monitoring during the test involved measurement of pressures at each piezometer and collection of gas samples for analysis. The gas samples were analyzed for oxygen, hydrogen, propane, and carbon dioxide using field instruments. The details of monitoring, sampling, and analysis are presented in Section 5.6.

Table 8 – Phase II Optimization Tests

Optimization Test	Flow Rate (cfm)	Flow Duration	Injection Location(s)	Gas Composition			
				Nitrogen	Hydrogen	LPG	CO2
1	90	4 hours	INJ2	88 percent	10 percent	1 percent	1 percent
2	30	12 hours	INJ2	88 percent	10 percent	1 percent	1 percent
3A	1.00	70 hours	INJ2	88 percent	10 percent	1 percent	1 percent
3B	1.00	98 hours	INJ1, INJ2, INJ3	88 percent	10 percent	1 percent	1 percent
3C	90	15 minutes	INJ1, INJ2, INJ3	79 percent	10 percent	10 percent	1 percent
4 - stage 1	30	45 min	INJ1, INJ2, INJ3	79 percent	10 percent	10 percent	1 percent
4 - stage 2	30	45 min	INJ2	79 percent	10 percent	10 percent	1 percent
4 - stage 3	0.5	Continuous	INJ2	79 percent	10 percent	10 percent	1 percent
5 - stage 1	20	125 min	INJ2	80 percent	10 percent	10 percent	0 percent
5 - stage 2	0.5	Continuous	INJ2	80 percent	10 percent	10 percent	0 percent
6	0.83	Continuous	P4-18/28	80 percent	10 percent	10 percent	0 percent
7A	1.00	Continuous	P4-18/28/38	80 percent	10 percent	10 percent	0 percent
7B	1.00	Continuous	P4-18/28	80 percent	10 percent	10 percent	0 percent
7C	1.67	Continuous	P4-18/28	79 percent	10 percent	10 percent	1 percent

Note – Specific injection screen depths (ft) are designated under “Injection Location” for Piezometer P4.

5.5.2 Phase III – Gas Mixture Injection

The objective of Phase III was to inject gas using the optimal injection strategy and quantification of perchlorate destruction in vadose zone soil. Phase III involved continuous injection of 100 cfm of the gas mixture identified in optimization test 7C (i.e., 79 percent nitrogen, 10 percent hydrogen, 10 percent LPG, and 1 percent carbon dioxide) into the 18- and 28-ft bgs screens of piezometer P4. The flow was divided equally into each screen (i.e., 50 cfm each) and was conducted for about five months. Gas injection conditions were not varied during this phase except during drilling to collect soil samples. Gas injection was not conducted during drilling for safety because of flammability. Gas sampling and analysis was conducted weekly and soil sample collection and analysis was conducted approximately monthly. Details on sampling and analysis are presented in Section 5.6.

5.5.3 Phase IV – LPG Injection

The perchlorate destruction results obtained during Phase III were not definitive because of heterogeneity. Therefore, additional funds were provided by ESTCP for more intensive soil sampling and analysis (see Section 5.6). Simultaneously, Aerojet General Corporation provided additional funds to operate the system using pure LPG instead of the gas mixture. Use of pure LPG had the potential to be more cost effective than the gas mixture if it was actually capable of promoting perchlorate biodegradation.¹ Injection of LPG was conducted at a flow rate of 100 cfm divided evenly amongst the 18- and 28-ft bgs screens of piezometer P4 for a period of about

¹ Treatability study results were not definitive with respect to the ability of pure LPG to promote perchlorate biodegradation as described in Section 5.3.1. However, the potential for LPG to promote perchlorate biodegradation had not been completely ruled out.

3 months. Following this injection period soil samples were collected and analyzed as described in Section 5.6.

5.5.4 Demobilization

Gas storage equipment was removed from the site upon completion of the demonstration. The gas control panel, wells, and piezometers were left in place. Aerojet will review this Draft Report and then make a decision whether to authorize CDM to abandon the wells and piezometers or to take ownership and responsibility of the infrastructure.

5.5.5 Investigation-Derived Waste

Excess soil was collected during the well construction and confirmation boring drilling events. At the request of Aerojet, this excess soil was placed on plastic sheeting and stored in the Propellant Burn Area, approximately 200 feet east of CDM-P1.

5.6 Sampling Methods

This section provides methods for gas and soil sampling and analysis. Additional quality assurance data are provided in Appendix E.

5.6.1 Gas Sampling and Analysis

Samples of gas from the piezometers and the gas injection manifold were collected and analyzed for hydrogen, propane, oxygen, carbon dioxide, relative humidity, and temperature using field instruments (Tables 9 and 10). Gas samples from the piezometers were collected using the vacuum pump that was integral to the RKI Eagle instrument used for analysis of propane, oxygen, and carbon dioxide. This instrument was connected in series with two other instruments – an H2scan HY-ALERTA 500™ handheld hydrogen leak detector and a Vaisala HMT360 humidity and temperature meter – and this analysis train was then connected to the piezometer tubing (Figure 33). The RKI Eagle pulled the gas sample from the piezometer into the gas analysis train allowing analysis of all parameters simultaneously. The gas injection manifold was under pressure which could damage the RKI Eagle pump. Therefore, gas samples were collected in Tedlar bags which in turn were connected to the gas analysis train.

Hydrogen concentrations were measured using an H2scan HY-ALERTA 500™ handheld hydrogen leak detector. This field instrument uses palladium alloy thin films to measure hydrogen in concentrations ranging from 15 parts per million by volume (ppmv) to percent concentrations. Concentrations from 15 to 5,000 ppmv are measured using a hydrogen-specific capacitor/metal oxide semiconductor. Concentrations from 0.5 percent (i.e., 5,000 ppmv) to 100 percent are measured using a hydrogen-specific resistor. The sensor is unique in its ability to measure hydrogen in oxic and anoxic atmospheres which was critical to this demonstration.

Table 9 - Total Number and Types of Samples Collected

Component	Matrix	Number of Samples	Analyte	Location
Baseline sampling	Soil: Screening measurement	67	Perchlorate, Nitrate+Nitrite Nitrogen, Moisture, VOCs	All soil borings, one sample every 5 to 10 feet
	Soil: Laboratory measurement	61	Perchlorate, Nitrate+Nitrite Nitrogen, Moisture	All soil borings, one sample every 10 feet
	Soil: Laboratory measurement	10	pH, TOC, Particle size distribution	CDM-INJ1 and CDM-P1 at selected intervals
	Soil gas: Field measurement	1 per monitoring point	O ₂ , H ₂ , Propane, CO ₂ , Temperature, Relative humidity	All subsurface monitoring devices
Technology performance sampling	Soil: Screening measurement	86	Perchlorate, Nitrate+Nitrite Nitrogen, Moisture, VOCs	All soil borings, one sample every 5 to 10 feet
	Soil: Laboratory measurement	48	Perchlorate, Nitrate+Nitrite Nitrogen, Moisture	All soil borings, one sample every 10 feet
	Soil gas: Field measurement	Weekly for Phase III and every other week for Phase IV	O ₂ , H ₂ , Propane, CO ₂ , Temperature, Relative humidity	All subsurface monitoring devices
Post-demonstration sampling	Soil: Screening measurement	66	VOCs	All soil borings, one sample every 10 feet
	Soil: Laboratory measurement	66	Perchlorate, Nitrate+Nitrite Nitrogen, Moisture	All soil borings, one sample every 10 feet

Table 10 - Analytical Methods for Sample Analysis

Matrix	Analyte	Method	Container	Preservative	Holding Time
Soil	Perchlorate	EPA 314.0	Glass jar	4 °C	28 days
	Perchlorate – screening	Ion-selective probe	Glass jar	4 °C	NA
	Nitrate+Nitrite Nitrogen	EPA 353.2	Glass jar	4 °C	28 days
	Nitrate - screening	Chemetrics K-6905	Glass jar	4 °C	NA
	Moisture	SM2540B	Glass jar	4 °C	28 days
	Moisture - screening	SM 2540B	Glass jar	4 °C	
	Total organic carbon	EPA 415.1	Glass jar	4 °C	28 days
	Particle size distribution	ASTM D422	Glass jar	4 °C	28 days
	pH	SM 9045C	Glass jar	4 °C	28 days
	VOCs – screening	PID	NA	NA	NA
Soil gas	Oxygen	Field	NA	NA	NA
	Hydrogen	Field	NA	NA	NA
	Propane	Field	NA	NA	NA
	Relative humidity	Field	NA	NA	NA
	Temperature	Field	NA	NA	NA

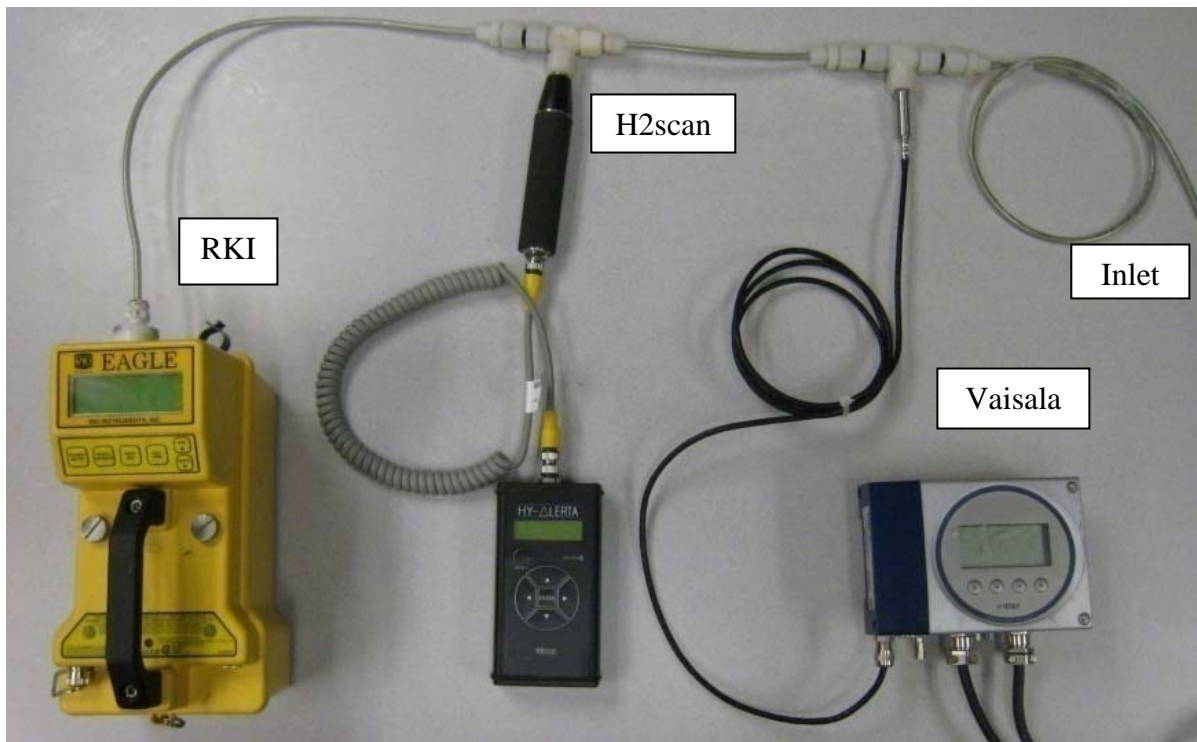

Figure 33 – Gas Sampling and Analysis Train

Propane, oxygen, and carbon dioxide concentrations were measured using an RKI Eagle portable gas detector. The RKI Eagle uses an infrared sensor for propane measurement, an electrochemical cell for oxygen measurement, and an infrared sensor for carbon dioxide measurement. The RKI Eagle was not capable of reporting propane concentrations greater than 30 percent. Propane concentrations of 30 percent or greater were reported as “> 30 percent”.

Temperature and relative humidity were measured using a Vaisala HMT360 humidity and temperature meter. Barometric pressure was measured using a Novalynx digital handheld barometer-altimeter. Atmospheric (above-ground) concentrations of flammable gases were monitored using a BW Technologies Micro Clip lower explosive limit (LEL) detector. Pressure in the piezometers was measured using Dwyer Magnehelic gauges.

Sampling frequency varied depending on the particular phase of the demonstration. During Phase II sampling was conducted multiple times per day and was varied in order to obtain transient data. During Phase III, sampling was conducted weekly. During Phase IV, sampling was conducted every two weeks. Depending on the particular piezometer and depth being measured, it normally took approximately one to two minutes for the gas concentration reading to stabilize after being connected to the sampling apparatus; gas concentrations were recorded after the readings stabilized. In addition to measuring gas concentrations at the piezometers, gas injection composition, flow rates, and pressures were also monitored using the same instruments plus rotameters and pressure gauges. The rotameters were standard meters calibrated for air at

atmospheric pressure. Rotameter readings are affected by gas pressure and density. The rotameter readings were thus corrected for gas density and pressure using the following equation provided by the instrument manufacturer (Key Instruments):

$$Q_i = CF_i \widehat{Q}_i \sqrt{\frac{P_i}{P}}$$

where,

Q_i is the actual flow rate of gas i (i.e., H₂, N₂, CO₂, or LPG) in units of scfm or scfh;

CF_i is the correction factor for gas i and is based on the relative densities of gas i and the rotameter calibration gas (i.e., air). The values of CF_i were provided by the rotameter manufacturer (Key Instruments) and are presented in Table 11;

\widehat{Q}_i is the rotameter reading for gas i in units of scfm or scfh;

P_i is the absolute pressure of gas i at the rotameter; and

P is the atmospheric pressure (1 atmosphere or 14.696 psia).

Table 11 – Rotameter Correction Factors

i	CF_i
N ₂	1.02
Propane (LPG)	0.80
H ₂	3.81
CO ₂	0.81

5.6.2 Soil Sampling and Analysis

In addition to the details presented in Table 9, Table 12 presents a detailed list of all soil samples collected including sampling dates and depths. Soil samples were collected during well and piezometer installation and confirmation boring drilling events. The soil samples collected during well and piezometer installation were representative of baseline conditions before gas injection. The confirmation borings were collected during Phases III and IV and the locations are depicted on Figure 34. Confirmation borings CB1 through CB8 were conducted during Phase III at four different times and each time at two different distances from the injection piezometer P4. Confirmation borings CB9 through CB19 were conducted at the end of Phase IV and were located as close to the existing wells and piezometers as practical. The Phase III confirmation borings were used to assess nitrate and perchlorate removal kinetics and the Phase IV confirmation borings were used to assess overall nitrate and perchlorate removal.

Table 12 – List of Soil Samples Collected

Sampling Location	Sampling Date	Sampling Depths (feet bgs)
INJ1	7/31/2006	5, 10, 15, 20, 25, 30, 35, 40, 45, 50, 55, 60, 65, 70
INJ2	10/26/07	5/5D, 10, 15, 20, 25/25D, 30, 35, 40, 45, 50
INJ3	10/17/2007	5/5D, 10, 15, 20, 25, 30, 35, 40, 45, 50
P1	7/27/2006	5, 10, 15, 20, 25, 30, 35, 40, 45, 50, 55, 60, 65, 70
P2	10/25/2007	5/5D, 10, 15, 20/20D, 25, 30, 35, 40, 45, 50
P3	10/23/2007	5, 10/10D, 15, 20, 25/25D, 30, 35, 40, 45, 50
P4	10/29/2007	5, 10, 15/15D, 20, 25, 30, 35, 40/40D, 45, 50
P5	10/24/2007	5, 10/10D, 15/15D, 20, 25, 30, 35, 40, 45, 50
P6	10/22/2007	5, 10, 15, 20/20D, 25, 30/30D, 35, 40, 45, 50
P7	10/16/2007	5, 10, 15, 20, 25, 30, 35/35D, 40
P8	10/11/2007-10/12/2007	5, 10, 15/15D, 30, 35, 40, 45, 50
CB1	4/18/2008	5, 10, 15, 20, 25, 30/30D, 35, 40, 45, 50
CB2	4/18/2008	5, 10, 15, 20, 25, 30/30D, 35, 40, 45, 50
CB3	6/10/2008	5, 10, 15, 20, 25, 30/30D, 35, 40, 45, 50
CB4	6/10/2008	5, 10, 15, 20, 25, 30/30D, 35, 40, 45, 50
CB5	7/10/2008	5, 10, 15, 20, 25, 30/30D, 35, 40, 45, 50
CB6	7/10/2008	5, 10, 15, 20, 25, 30/30D, 35, 40, 45, 50
CB7	9/2/2008	5, 10, 15, 20, 25, 30/30D, 35, 40, 45, 50
CB8	9/2/2008	5, 10, 15, 20, 25, 30/30D, 35, 40, 45, 50
CB9	12/2/2008	10, 20, 30/30D, 40, 50
CB10	12/2/2008	10, 20, 30/30D, 40, 50
CB11	12/3/2008	10, 20, 30/30D, 40, 50
CB12	12/3/2008	10, 20, 30/30D, 40, 50
CB13	12/3/2008	10, 20, 30/30D, 40, 50
CB14	12/3/2008	10, 20, 30/30D, 40, 50
CB15	12/3/2008	10, 20, 30/30D, 40, 50
CB16	12/3/2008	10, 20, 30/30D, 40, 50
CB17	12/3/2008	10, 20, 30/30D, 40, 50
CB18	12/3/2008	10, 20, 30/30D, 40, 50
CB19	12/3/2008	10, 20, 30/30D, 40, 50

D = duplicate sample collected

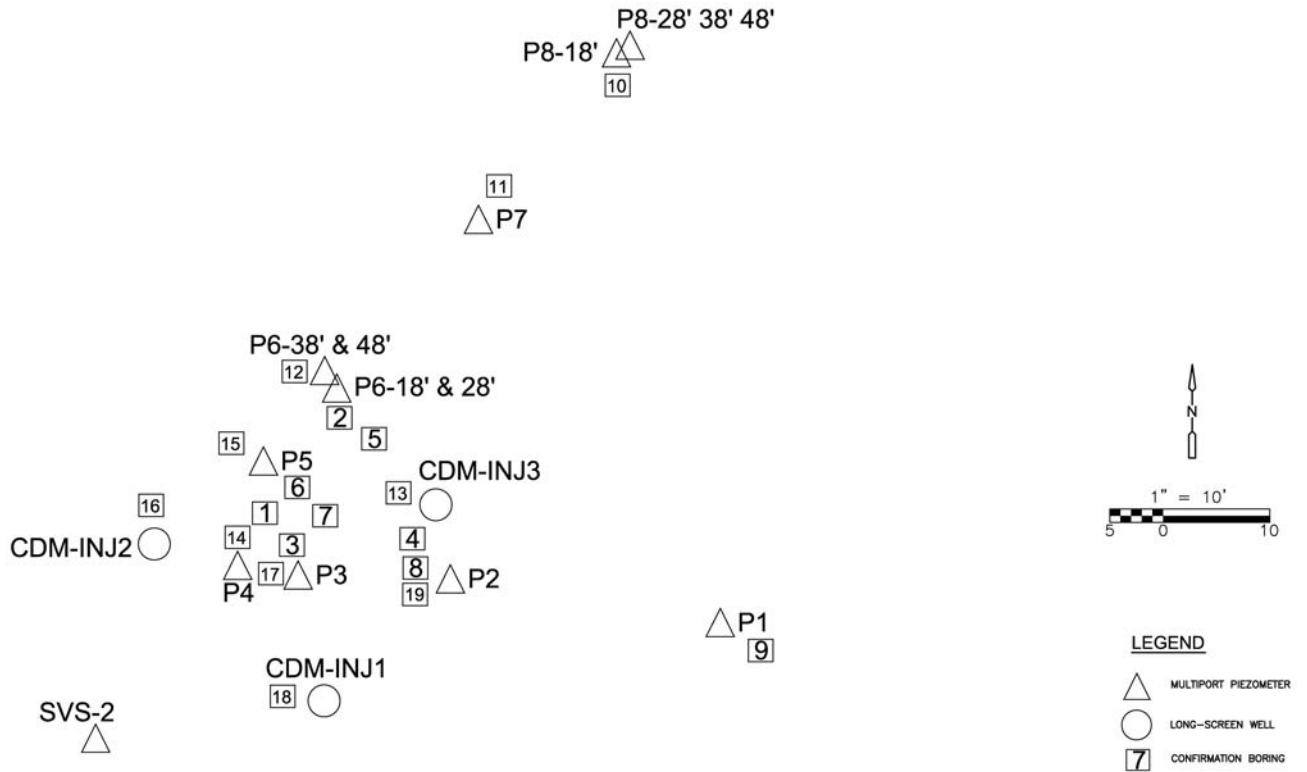

Figure 34 – Well Piezometer and Confirmatory Boring Locations

As described in Sections 5.2.1 and 5.4.1, each borehole was continuously cored from ground surface to total depth. The cores were logged by a CDM geologist in accordance with ASTM Standard D2488 and boring logs with soil descriptions are included in Appendix B). Core samples were screened in the field for volatile organic compounds (VOCs) by placing a portion of the sample into a zip-lock bag, waiting approximately 10 minutes, placing the tip of a photo-ionization detector (PID) into the bag, and then taking a measurement.

Soil samples were collected at 5-foot intervals and placed in 8-ounce glass jars. Sample jars were then sealed in zip-locks bags which were placed in an ice-chilled cooler prior to shipment to the lab. Soil samples were shipped to Laucks Testing Laboratory which was acquired by Pace Analytical (Seattle, Washington) for analysis (Table 10). Some sample analyses were subcontracted to Weck Laboratories (Industry, California).

In addition to the laboratory analyses, screening analyses of soil samples for perchlorate, nitrite+nitrite nitrogen, and moisture were conducted on baseline samples and technology performance samples (Table 9). A quality assurance review of these data determined that they were not comparable to the laboratory analyses. Therefore the screening results for these analytes are not discussed further in this report.

5.7 Sampling Results

Phase I results were presented in Section 5.3. This section presents the results of Phases II through IV.

5.7.1 Tracer Tests

Tracer tests were conducted during Phase II to characterize hydrogen transport through the vadose zone under various injection strategies. Table 13 presents the injection conditions for each test. The gas flow rate was varied (e.g., from about 10 cfm to 90 cfm) and the number of injection wells was varied (either one or three wells). During each test the hydrogen and oxygen concentrations were monitored in the piezometers. Figure 35 shows example data for Test 4. Complete tracer test data are presented in Appendix C.

Analysis of tracer test data was accomplished by calculating the volume of injected gas required to attain 50 percent of the injected hydrogen concentration in each piezometer sampling point. Figure 36 shows a graphical representation of this analysis. The rectangles that are colored green or blue indicate piezometer locations where the hydrogen concentration attained at least 50 percent of the injected concentration during the indicated test. The rectangles that are labeled blue indicate the test condition that resulted in the minimum gas volume needed to attain the 50 percent target at the indicated piezometer location. For example, Test 1 resulted in attainment of the 50 percent target in P3 at 18, 28, and 38 ft bgs but not at 48 ft bgs. Test 1 also was the test condition that resulted in the minimum gas volume needed to attain the 50 percent target in P3 at 18 ft bgs. Test 3 was the test condition that resulted in the minimum gas volume needed to attain the 50 percent target in P3 and 28 and 38 ft bgs. Actual gas volume data are summarized in Table 14.

Table 13 – Tracer Test Operating Conditions

Test	Target Flow Rate	Measured Flow Rate	Injection Wells			Injected Hydrogen Concentration
	(cfm)	(cfm)	INJ1	INJ2	INJ3	(percent)
1	10	9.6		X		6.5
2	20	19		X		7.4
3	30	27		X		4.1
4	60	63		X		6.3
5	90	87		X		3.6
6	30	29	X	X	X	8.0
7	60	59	X	X	X	5.0
8	90	84	X	X	X	5.0

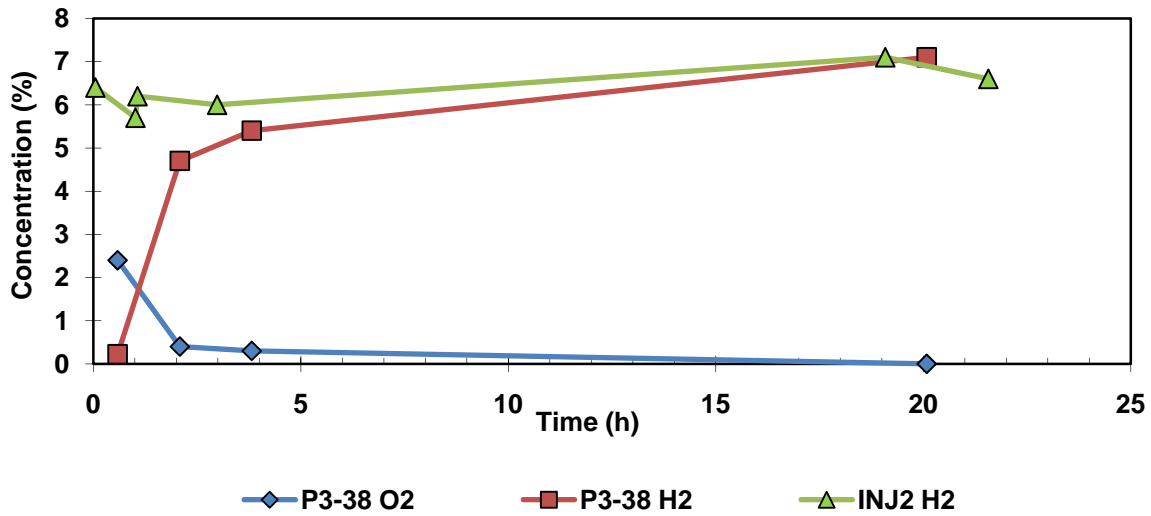

Figure 35 – Example Transient Gas Concentrations During Tracer Test 4

Test	Wells	Flow (cfm)	Depth (feet)															
			18	33	48	68	18	28	38	48	18	28	38	48	18	28	38	48
			P4-8.2ft				P3-14 ft				P2-28 ft				P1-54 ft			
1	1	10	█	█	█		█	█	█		█							
2	1	20	█	█	█	█	█	█	█	█	█							
3	1	30	█	█	█	█	█	█	█	█	█	█						
4	1	60	█	█	█	█	█	█	█	█	█	█				█		
5	1	90	█	█	█	█	█	█	█	█	█	█						
6	3	30	█	█	█		█	█	█	█	█	█				█		
7	3	60	█	█	█		█	█	█	█	█	█	█	█		█		
8	3	90	█	█	█		█	█	█	█	█	█	█	█	█	█		

Test	Wells	Flow (cfm)	Depth (feet)															
			18	28	38	48	18	28	38	48	28	38	48	18	28	38	48	
			P5-13ft				P6-22ft				P7-43ft				P8-64ft			
1	1	10	█	█	█		█	█	█		█		█	█				
2	1	20	█	█	█		█	█	█		█		█	█				
3	1	30	█	█	█	█	█	█	█	█	█	█	█	█				
4	1	60	█	█	█	█	█	█	█	█	█	█	█	█				
5	1	90	█	█	█	█	█	█	█	█	█	█	█	█				
6	3	30	█	█	█		█	█	█	█	█	█	█	█				
7	3	60	█	█	█		█	█	█	█	█	█	█	█				
8	3	90	█	█	█		█	█	█	█	█	█	█	█				

Note - Distances listed after piezometer labels refer to distance from INJ2.

- 50% of injected H₂ concentration attained with minimum gas volume relative to other tests
- 50% of H₂ concentration attained
- 50% of H₂ concentration not attained

Figure 36 – Summary Analysis of Tracer Test Data.

Table 14 – Distribution of Gas Volumes Required to Attain 50 Percent of Injected Hydrogen Concentration in Piezometers

Parameter	Injected Gas Volume (cubic feet)
Average	10,000
Median	6,900
Standard deviation	10,000
Minimum	410
Maximum	70,000

Several conclusions can be derived from the tracer tests:

- Hydrogen gas was capable of being transported 64 feet away from the point of injection under all injection conditions.
- Hydrogen transport diminished with depth due to the buoyancy of this low molecular weight gas.

- Hydrogen transport was better in the northerly direction (i.e., P5 to P8) compared to the easterly direction (i.e., P4 to P1) likely because of historical gold dredging operations that operated in a north-south direction.
- In general, Test 3 conditions – injection of an intermediate flow rate of 30 cfm into one well – resulted in minimum gas volume requirements to achieve 50 percent of hydrogen concentrations throughout the treatment area. However, transport of hydrogen to the distal eastern piezometers (i.e., P1 and P2) was most efficient when high flow rates of 60 to 90 cfm were injected into all three wells.
- Gas volumes required to achieve 50 percent of injected hydrogen concentrations in a given piezometer ranged from 410 to 70,000 cubic feet.

While these tracer tests demonstrated that hydrogen could effectively be transported in the vadose zone, the gas flow rates that were required would not be economical if they needed to be injected continuously. During these tests, oxygen concentrations were often reduced to less than one percent, but upon cessation of injection, oxygen concentrations were observed to increase. Thus, additional optimization testing was required to identify cost-effective conditions capable of maintaining elevated electron donor concentrations and diminished oxygen concentrations in the vadose zone. These tests are described in the next section.

5.7.2 Optimization Tests

Several optimization tests were conducted during Phase II to determine the best method to minimize oxygen concentrations, maximize electron donor concentrations, and minimize gas volume. Table 15 illustrates the various test conditions that were evaluated. Table 16 presents the minimum oxygen concentrations that were observed during each test. Appendix C presents complete gas concentration and operating data from these tests.

Table 15 – Optimization Test Conditions

Optimization Test	Flow Rate (cfm)	Flow Duration	Injection Location(s)	Gas Composition			
				Nitrogen	Hydrogen	LPG	CO ₂
1	90	4 hours	INJ2	88%	10%	1%	1%
2	30	12 hours	INJ2	88%	10%	1%	1%
3A	1.00	70 hours	INJ2	88%	10%	1%	1%
3B	1.00	98 hours	INJ1, INJ2, INJ3	88%	10%	1%	1%
3C	90	15 minutes	INJ1, INJ2, INJ3	79%	10%	10%	1%
4 - stage 1	30	45 min	INJ1, INJ2, INJ3	79%	10%	10%	1%
4 - stage 2	30	45 min	INJ2	79%	10%	10%	1%
4 - stage 3	0.5	Continuous	INJ2	79%	10%	10%	1%
5 - stage 1	20	125 min	INJ2	80%	10%	10%	0%
5 - stage 2	0.5	Continuous	INJ2	80%	10%	10%	0%
6	0.83	Continuous	P4-18/28	80%	10%	10%	0%
7A	1.00	Continuous	P4-18/28/38	80%	10%	10%	0%
7B	1.00	Continuous	P4-18/28	80%	10%	10%	0%
7C	1.67	Continuous	P4-18/28	79%	10%	10%	1%

Table 16 – Optimization Test Minimum Oxygen Concentrations

Piezometer	Depth (feet)															
	18	28	38	48	18	28	38	48	18	28	38	48	18	33	48	68
	P4				P3				P2				P1			
Test	Minimum Oxygen Concentration (%)															
1	0.2	0	1.6	0.1	1.7	0.1	0.2	3.8	2.8	1.6	3.5	2.8	17.3	11.9	17.5	14.3
2	0.1	0	1	1	1.2	0.1	0.1	7	6.8	4.5	6.4	6.4	18.8	16.7	16.9	0
3A	0.6	5.1	7.3	18.8	2.9	7.7	7.3	6.8	14.6	13.9	8.3	6.2	19.1	18.5	17.1	0
3B	0.4	8.3	8.4	19.3	0.8	10.1	12.1	7.2	8.9	14	10.8	19.9	19	18.8	16.9	15.7
3C	1.2	8.7	8.8	16.5	0.9	8.8	9.9	16.4	5.1	12.4	11.7	19.5	19.1	19	NA	NA
4	0	1.6	6.1	12.7	1.6	1.7	7.2	15	14.1	16	NA	NA	NA	NA	NA	NA
5	0.9	0.3	4.2	8.5	2.1	0.3	6.3	12.9	NA	NA	NA	NA	NA	NA	NA	NA
6	NA	NA	0.2	1.8	0	0	0	5.4	3.5	1.1	5.2	9.8	18.7	10.3	17	14.3
7A	NA	NA	NA	1.6	0.1	0.1	0	3.9	2.3	2.1	4.5	4.1	17.5	8.9	16.9	13.4
7B	NA	NA	1.3	1.8	0.3	5.7	4.5	8.3	8.2	7.1	5.3	4.8	16.2	12.6	16.5	12.9
7C	NA	NA	0.3	0.2	0	0	0	1.5	4.2	2.6	3.5	0.7	17.4	13	16.8	12.4

Piezometer	Depth (feet)															
	18	28	38	48	18	28	38	48	28	38	48	18	28	38	48	
	P5				P6				P7				P8			
Test	Minimum Oxygen Concentration (%)															
1	0.2	0	0	2.6	0	0	0.4	8.7	0	0	14.7	0.1	0.5	13.4	12.5	
2	0.2	0	0.2	7.5	0	0	1	11.6	0.1	0	14.6	0.1	0.2	13.8	13	
3A	0	7.1	8.3	10.6	1.2	8.6	6.4	18.9	11	11.8	14.5	10.2	8.8	14.2	13.4	
3B	0.5	11	8.5	11.2	2.3	11.6	8.7	20.1	11.4	12.2	14.5	10.1	9.1	14.3	13.5	
3C	0.6	8.7	9.4	11	4.4	9.4	10	20.2	11.1	11.6	14.3	11	9.1	14.2	13.7	
4	0	0.4	7.2	11.6	8.5	1.4	NA	NA	NA	NA	NA	NA	NA	NA	NA	
5	0.4	0.1	4.7	10.8	NA	NA	NA	NA	NA	NA	NA	NA	NA	NA	NA	
6	0	0	0.9	6.7	0	0.4	6.2	10	0.1	0.1	6	6.5	7.8	13.2	NA	
7A	0	0.3	0.4	5.1	0	0.6	3.1	9.2	0.2	0.1	13.5	6.6	7.3	10.3	NA	
7B	0.2	6	1.5	6.9	2	6.2	3.1	6.9	8.9	6.4	12.9	11.9	12.3	9.5	NA	
7C	0	0.6	0	4.1	0	1.4	2.8	5.3	2.3	2.7	10.4	10.8	12.7	8.8	NA	

Color Key - Minimum Oxygen Concentration (%)												
0	1	2	3	4	5	6	7	8	9	10	15	21

Optimization Tests 1 and 2 evaluated equal-volume (i.e., 21,600 cubic feet) injection pulses of nitrogen, hydrogen, LPG, and carbon dioxide using different combinations of flow rate and duration. The objective of these tests was to determine whether gas pulses depleted oxygen in the vadose zone. Table 16 shows that oxygen was capable of being depleted in many of the piezometers and Test 1 conditions were slightly better at achieving this objective. However, the data in Figure 37 show that oxygen concentrations likely increased to greater than one percent within hours. Tests 3A through 3C evaluated alternative pulsing strategies but these were incapable of decreasing oxygen concentrations to less than one percent in many of the piezometers. Thus pulsing did not appear to be an effective injection strategy at this site.

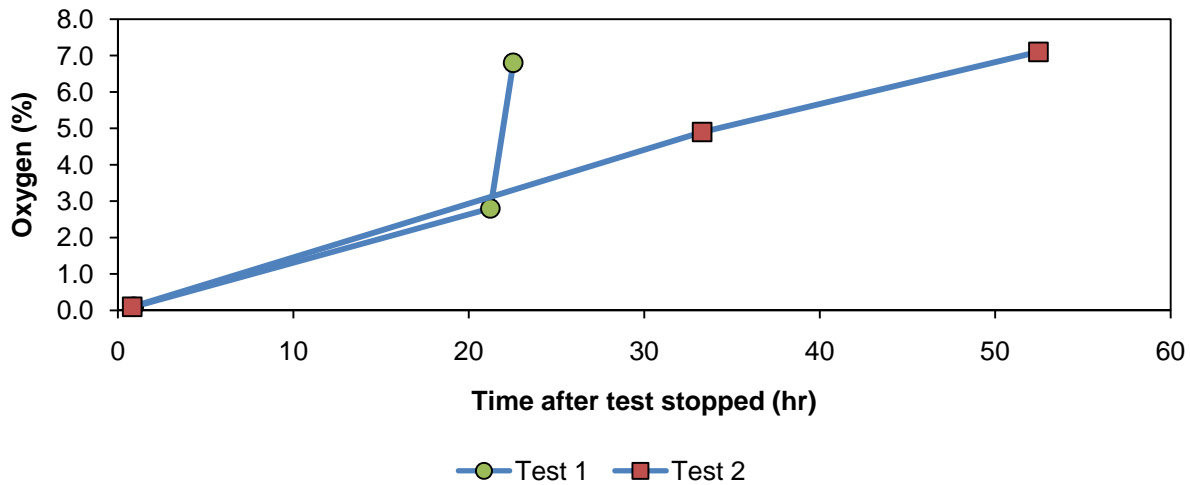

Figure 37 - Oxygen Concentration Transients in Piezometer P3 at 28 ft bgs after Gas Injection Stopped

Tests 4 and 5 were conducted to evaluate an initial gas pulse at a high flow rate followed by a continuous low flow rate. The results of these tests indicated that significant depletion of oxygen was observed only at the 18 and 28 ft bgs depths. For example, Table 16 shows that oxygen concentrations in P3, P4, and P5 were four percent or greater at depths of 38 and 48 ft bgs. The reason that ineffective oxygen depletion was observed at depth was attributed to the long 40-to-70-foot well screens used in injection wells INJ1, INJ2, and INJ3. Gas flow was preferentially directed toward the top of the screen and minimal flow exited the bottom of the screen.

Based on these results, gas injection into piezometer P4 was attempted in Tests 6 and 7 in an effort to better direct gas throughout the 50-foot deep target treatment zone. Gas was injected into the top two or three piezometer screens at total flow rates ranging from 0.83 to 1.7 cfm. Table 16 shows that oxygen concentrations in P3 and P5 were one percent or less at depths of 18, 28, and 38 ft bgs but not at 48 ft bgs. This injection approach was successful and superior to that used in Tests 4 and 5. Test 7B was not as successful as Tests 6 and 7 and the reasons for this difference was not determined. Nevertheless, Test 7C was initiated with a slightly greater flow rate (1.67 cfm compared to 1.00 cfm) and results were positive. Oxygen concentrations were readily depleted both with respect to distance from the injection point and depth. Test 7C conditions were selected as steady state operating conditions for the N₂/H₂/LPG/CO₂ gas mixture. Results for steady state operation are described in the next section.

5.7.3 Steady State Gas Concentrations

Continuous gas injection into P4 at 18 and 28 ft bgs at a total flow rate of 1.67 cfm (100 cfh) was conducted during Phase III with a mixture of nitrogen (79 percent), hydrogen (10 percent), LPG (10 percent) and carbon dioxide (one percent). Figures 38 through 41 show the steady state oxygen, hydrogen, and propane concentrations measured during this injection period. The data presented in these figures include data from all piezometers. Measured oxygen concentrations within the 10-foot target ROI ranged from 0.04±0.14 percent to 1.4±2.0 percent. Low oxygen

concentrations were attainable at depths of 38 and 48 ft bgs even though gas was injected only into the 18 and 28 ft bgs piezometer screens. Oxygen concentrations increased with the distance from the point of injection (Figure 38).

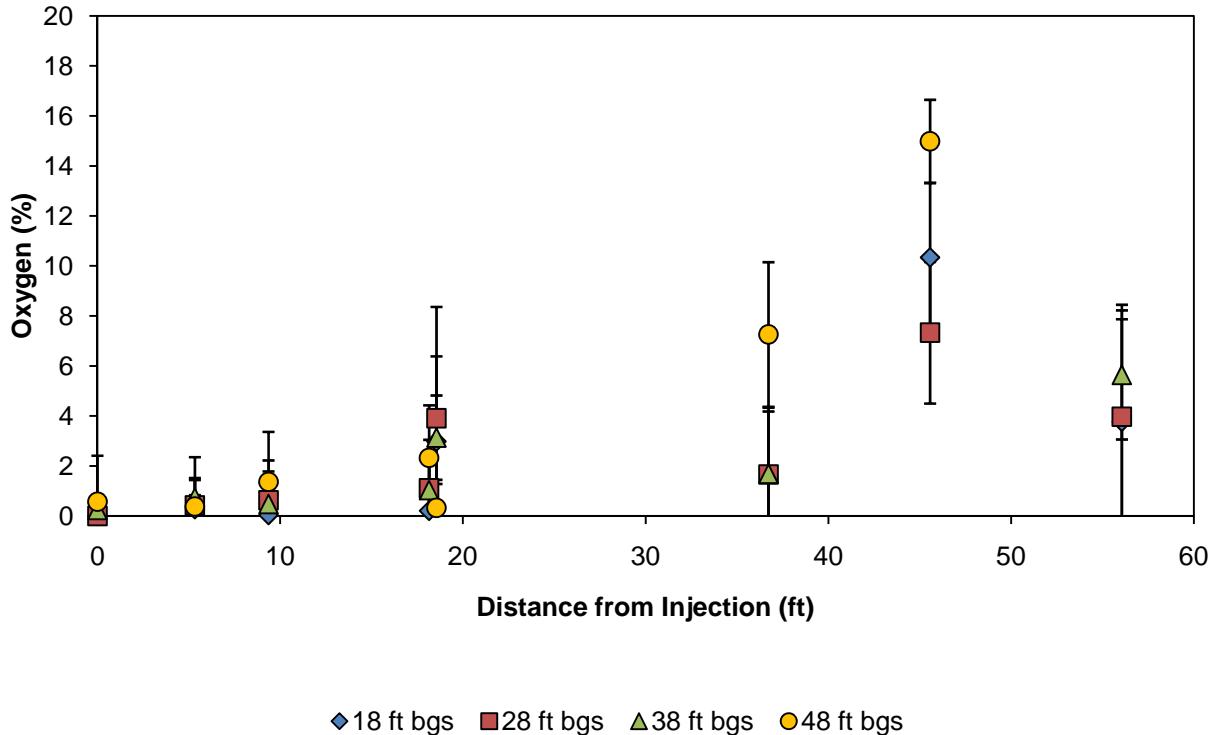

Figure 38 - Average Oxygen Concentrations during N₂/H₂/LPG/CO₂ Injection. Error bars are ±1 standard deviation.

Hydrogen concentrations approaching the injected concentration of 10 percent were most readily obtained at the 18 ft bgs location (Figure 39). Hydrogen concentrations decreased as the depth increased and as the distance from injection increased. Nevertheless, hydrogen was detectable at depths below the point of injection within the 10-foot target ROI (Figure 40). Hydrogen concentrations ranged from 0.25±0.20 percent to 1.1±1.7 percent at 38 ft bgs and from 0.070±0.034 percent to 0.11±0.16 percent at 48 ft bgs. Hydrogen was detected at concentrations greater than one percent in P8 located 56 feet north east from the point of injection at 18 and 28 ft bgs. This piezometer is located northerly from the point of injection. In comparison, hydrogen concentrations were less than 0.01 percent in P1 located 41 feet east of the point of injection. This difference is likely attributable to lithologic heterogeneities introduced from historical gold dredging operations that induced greater pneumatic permeability in the northerly direction.

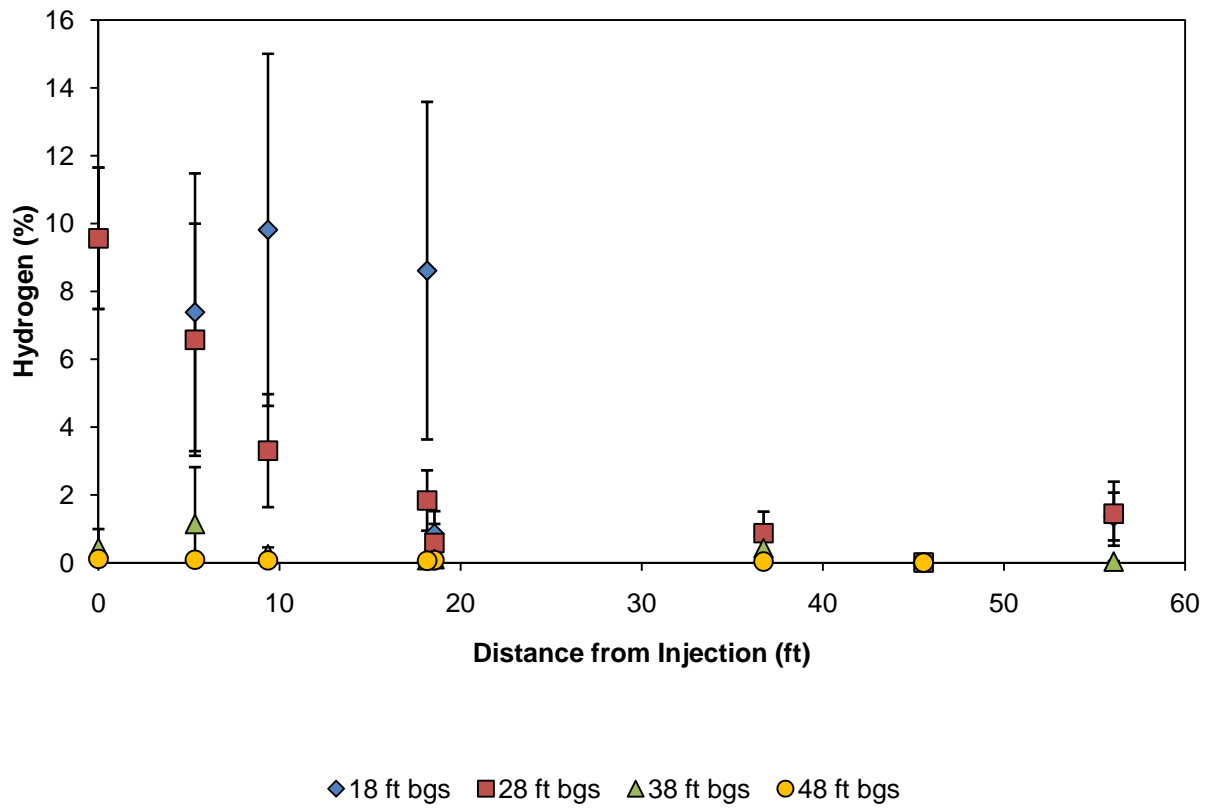

Figure 39 – Average Hydrogen Concentrations during N₂/H₂/LPG/CO₂ Injection. Error bars are ±1 standard deviation.

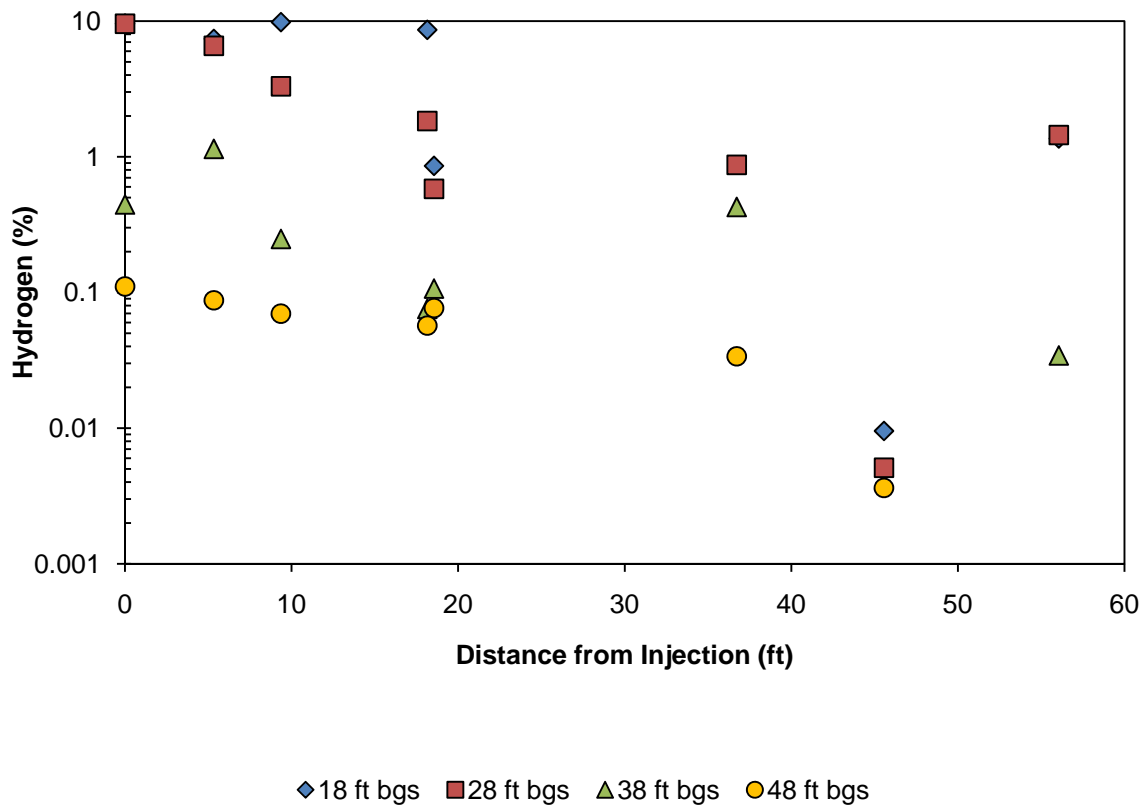

Figure 40 – Average Hydrogen Concentrations (log scale) during N₂/H₂/LPG/CO₂ Injection

Propane was more easily distributed than hydrogen both with respect to distance from injection and depth (Figure 41). Measured propane concentrations within the 10-foot target ROI ranged from 8.6±1.6 percent to 9.6±2.4 percent. The lowest detected concentration anywhere was 0.40±0.45 percent in piezometer P1 at 48 ft bgs.

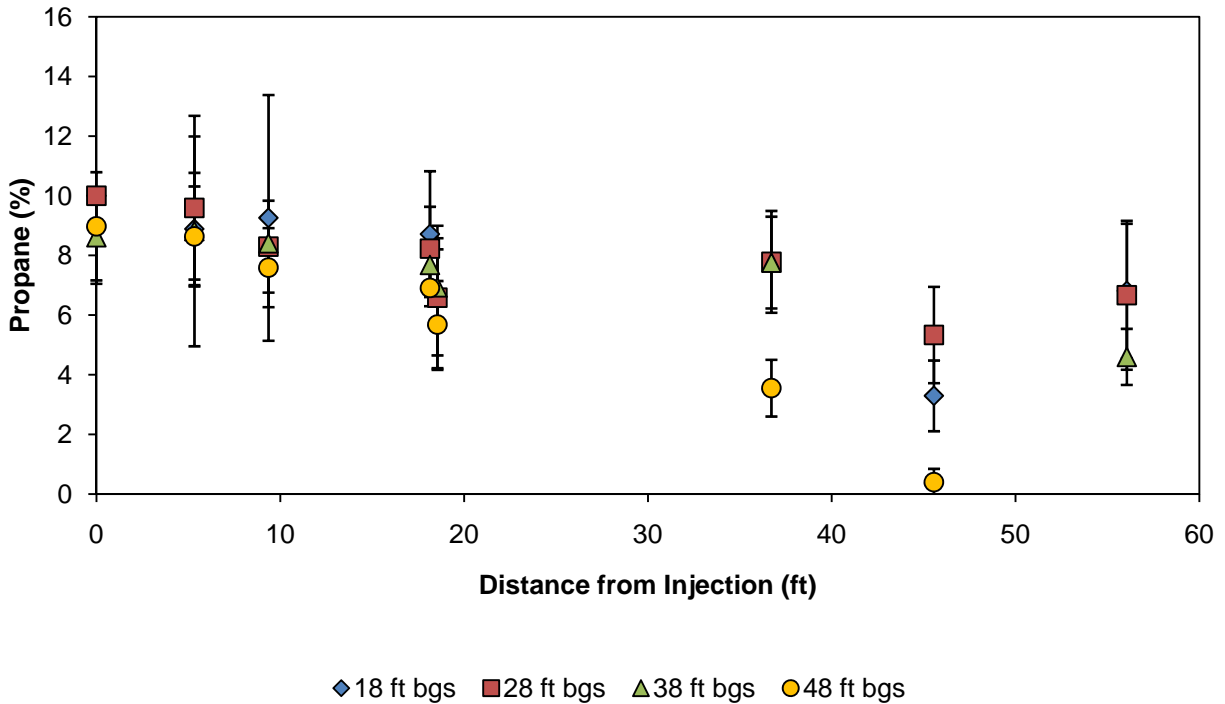

Figure 41 – Average Propane Concentrations during N₂/H₂/LPG/CO₂ Injection. Error bars are ±1 standard deviation.

The above results indicate that continuous injection of the N₂/H₂/LPG/CO₂ gas mixture resulted in oxygen depletion and electron donor distribution within the 10-ft target ROI especially at depths ranging from 18 to 38 ft bgs. While hydrogen was detected at 48 ft bgs within the 10-ft target ROI, the concentrations were only 0.1 percent. Oxygen depletion and electron donor distribution outside of the 10-ft target ROI was observed; however, the results were variable. Historical gold dredging operations affected soil lithologic conditions such that greater oxygen depletion and electron donor distribution were observed in a northerly direction (i.e., P4 to P8) compared to an easterly direction (i.e., P4 to P1). While propane was readily distributed at all depths, hydrogen was preferentially distributed at shallower depths.

Continuous gas injection into P4 at 18 and 28 ft bgs at a total flow rate of 1.67 cfm (100 cfh) was conducted in Phase IV with pure LPG. Figures 42 and 43 show the steady state oxygen and propane concentrations measured during this injection period. Measured oxygen concentrations within the 10-foot target ROI ranged from 0.029±0.049 percent to 5.9±1.5 percent (Figure 42). Low oxygen concentrations were attainable at depths of 38 and 48 ft bgs even though gas was injected only into the 18 and 28 ft bgs piezometer screens. These low oxygen concentrations were observed at distances up to 56 ft away from the point of injection. However, oxygen concentrations were high at depths of 18 and 28 ft bgs both inside and outside of the 10-ft target ROI. The reason was attributable to the density of propane causing it to sink. Thus LPG alone was not capable of satisfactorily depleting oxygen within the 10-ft target ROI. On the other hand,

LPG alone was capable of depleting oxygen at depth at greater distances from the point of injection compared to the gas mixture (Figure 43).

Propane was easily distributed at significant distances from the point of injection at the 28, 38, and 48-ft bgs depths (Figure 43). The gas analyzer was not capable of reporting propane concentrations greater than 30 percent. Thus, concentrations shown on Figure 43 with values of 30 percent were likely greater than 30 percent. Distribution of propane at 18 ft bgs was relatively poor and this result is consistent with the observed oxygen concentration profiles (Figure 42). However, propane distribution at 28 ft bgs was relatively good which makes the elevated oxygen concentrations surprising.

The above results indicate that continuous injection of pure LPG was less effective than the gas mixture with respect to oxygen depletion and electron donor distribution. However, injection of pure LPG did have a distinct advantage with respect to oxygen depletion and electron donor distribution at depths greater than the point of injection.

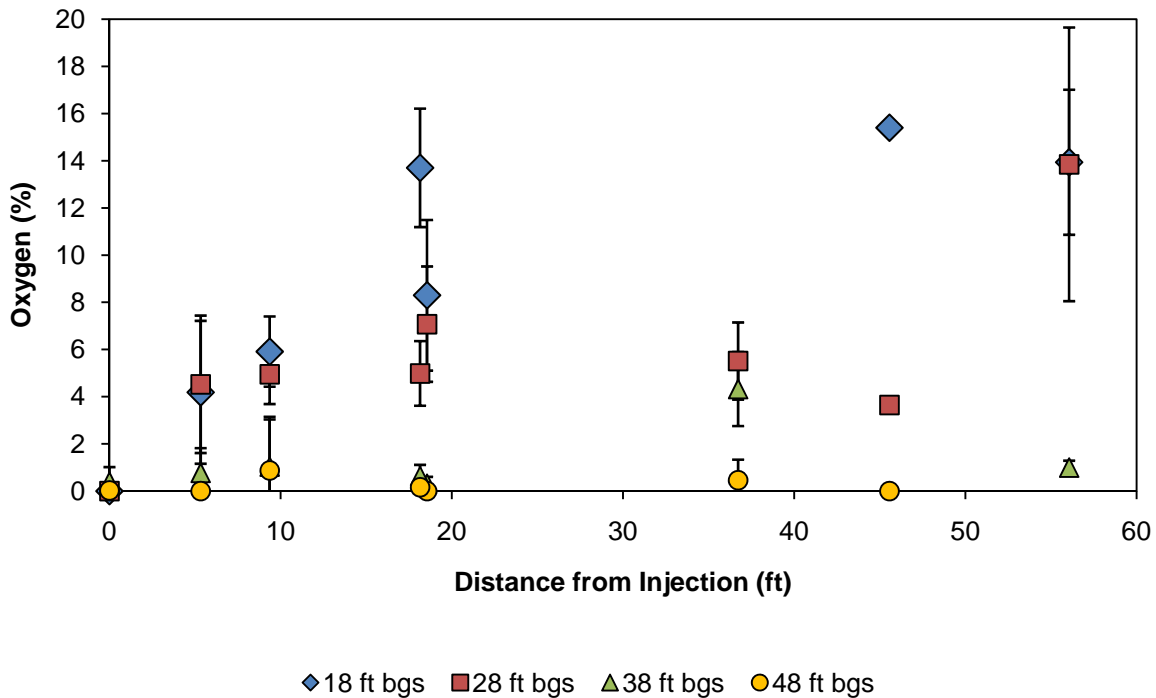

Figure 42 – Average Oxygen Concentrations during LPG Injection. Error bars are ±1 standard deviation.

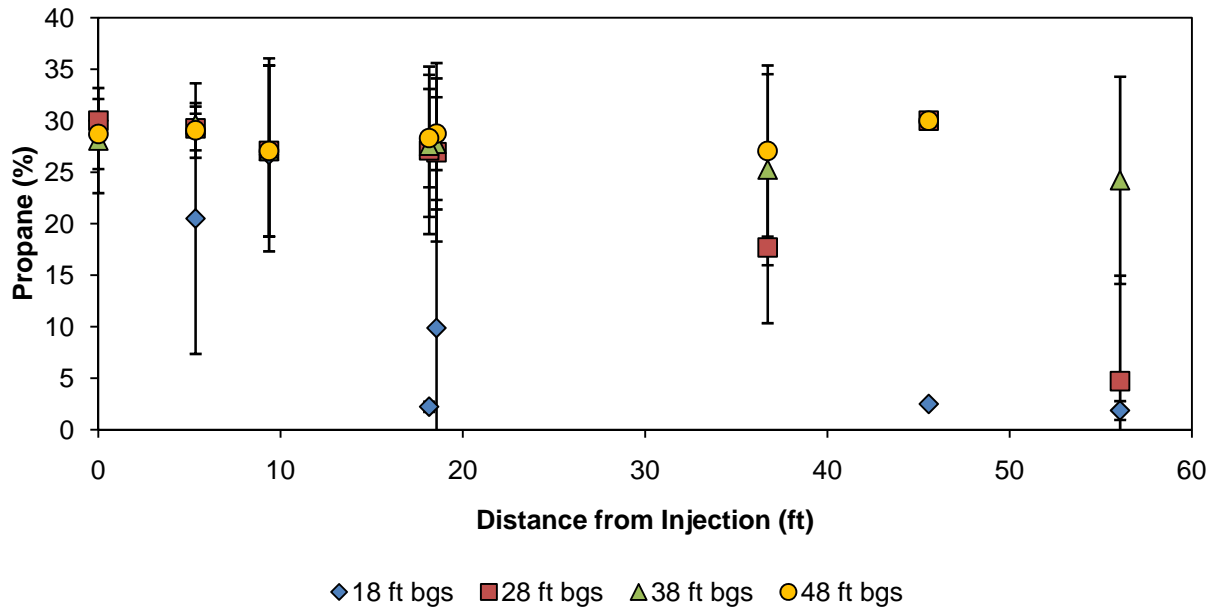

Figure 43 – Average Propane Concentrations during LPG Injection. Maximum propane concentration measurable by instrument was 30 percent. Error bars are ± 1 standard deviation.

5.7.4 Perchlorate and Nitrate Concentrations in Soil

Baseline concentrations of perchlorate and nitrate plus nitrite in soil were determined during installation of injection wells and piezometers. Final concentrations of these analytes in soil were determined after completion of Phase IV. To minimize complicating effects of soil heterogeneity on data analysis, final soil samples were collected directly adjacent to each injection well and piezometer. The distance between the well or piezometer and each adjacent soil boring ranged from 1.5 to 2.0 feet. Comparisons of baseline and final soil concentrations of perchlorate and nitrate plus nitrite (dry weight basis) are shown in Figures 44 through 55. These data represent samples collected along a transect from P4 to P1 (the “EW transect”) and along the transect from P4 to P8 (the “NS transect”). Baseline concentrations are representative of soil samples collected during piezometer installation. Final concentrations are representative of the final confirmation borings. Figures 49 and 55 summarize the data for samples collected within the 10-ft target ROI.

Significant perchlorate concentration reductions were observed within the 10-ft target ROI and these reductions were especially pronounced in the shallower vadose zone horizons. The concentration reductions within the 10-ft target ROI ranged from one to three orders of magnitude except in the 45-to-50 ft bgs horizon. Initial concentrations of perchlorate within the 10-ft target ROI and the 10-to-40-ft bgs depth interval ranged from 2,600 to 75,000 $\mu\text{g}/\text{kg}$. Final perchlorate concentrations ranged from < 13 to 8,800 $\mu\text{g}/\text{kg}$. Seven final soil samples (i.e., six sample locations plus one duplicate) were ND for perchlorate (< 13 to < 15 $\mu\text{g}/\text{kg}$).

Significant nitrate concentration reductions were observed within the 10-ft target ROI and, unlike perchlorate, nitrate concentration reductions were observed at all depths. Reductions in nitrate concentrations were also observed outside the 10-ft target ROI and these reductions appeared to be more pronounced at the greater depths. The concentration reductions within the 10-ft target ROI ranged from one to two orders of magnitude. Initial concentrations of nitrate

plus nitrite within the 10-ft target ROI ranged from 2.0 to 8.6 mg-N/kg. Final nitrate plus nitrite concentrations ranged from < 0.054 to 2.9 mg-N/kg. Six final soil samples (i.e., five sample locations plus one duplicate) were ND for nitrate plus nitrite (< 0.054 to < 0.057 mg-N/kg).

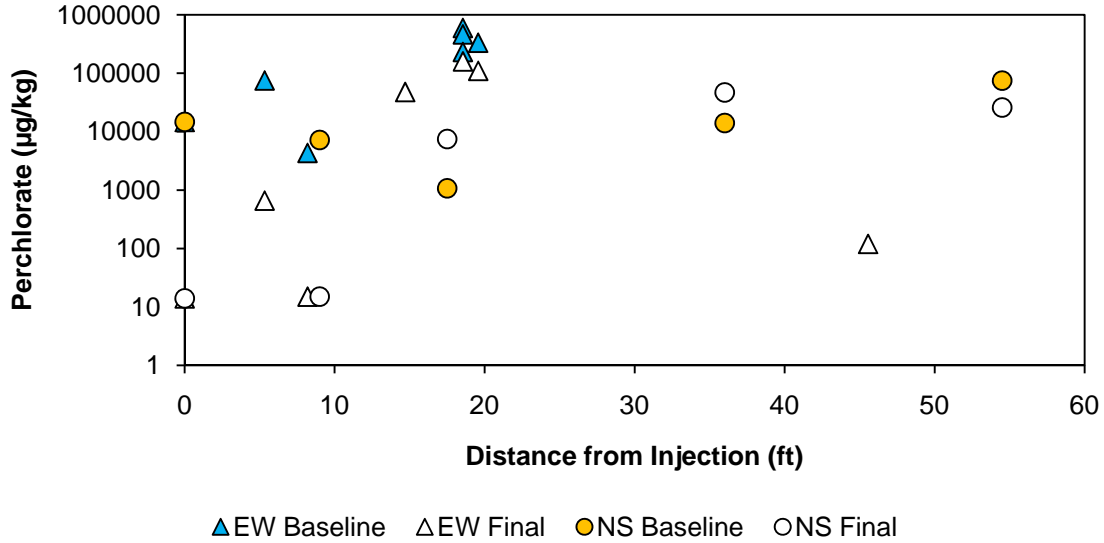

Figure 44 – Perchlorate Concentrations 5 to 10 ft bgs

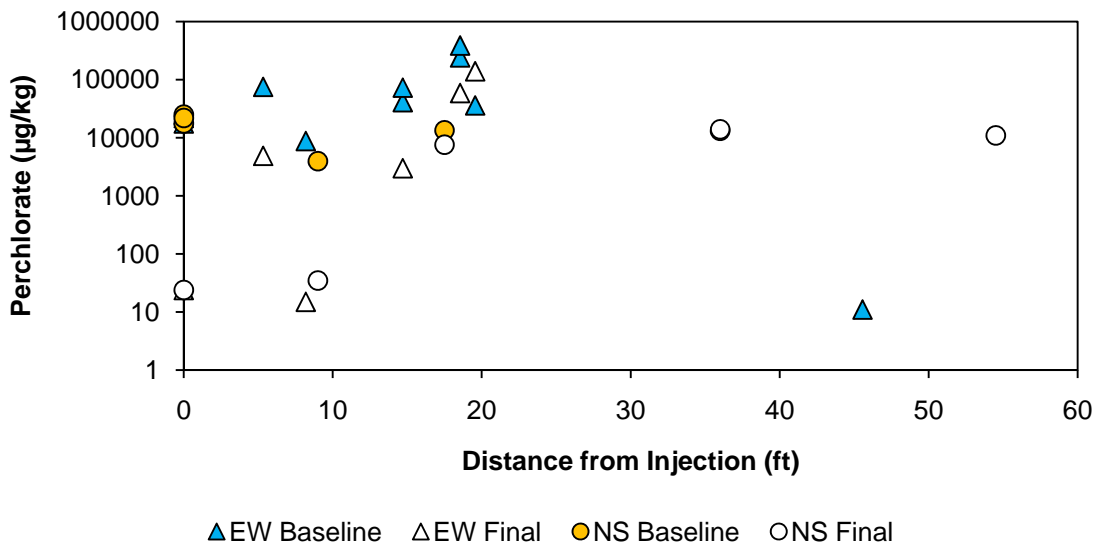

Figure 45 – Perchlorate Concentrations 15 to 20 ft bgs

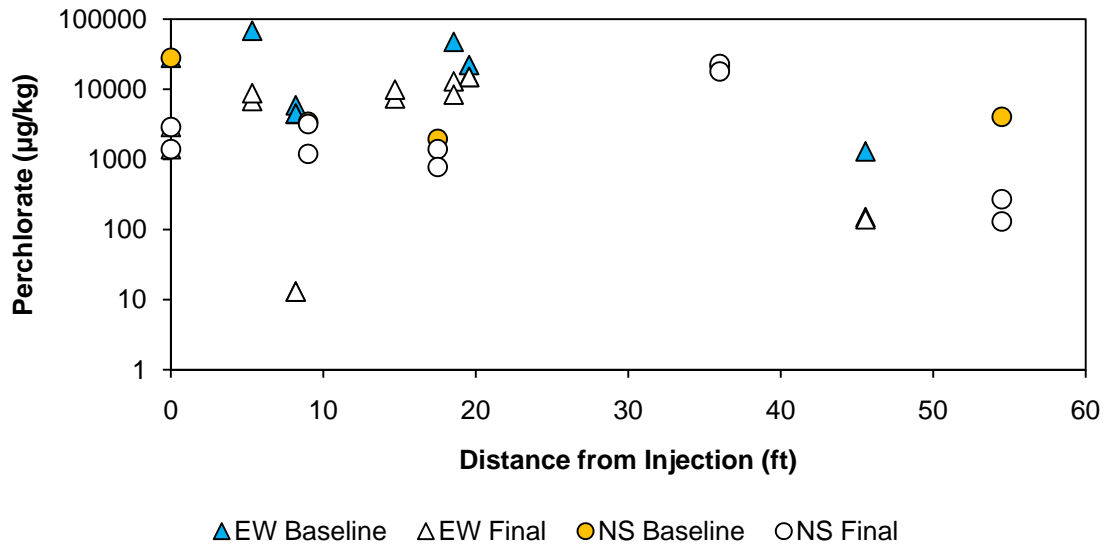

Figure 46 – Perchlorate Concentrations 25 to 30 ft bgs

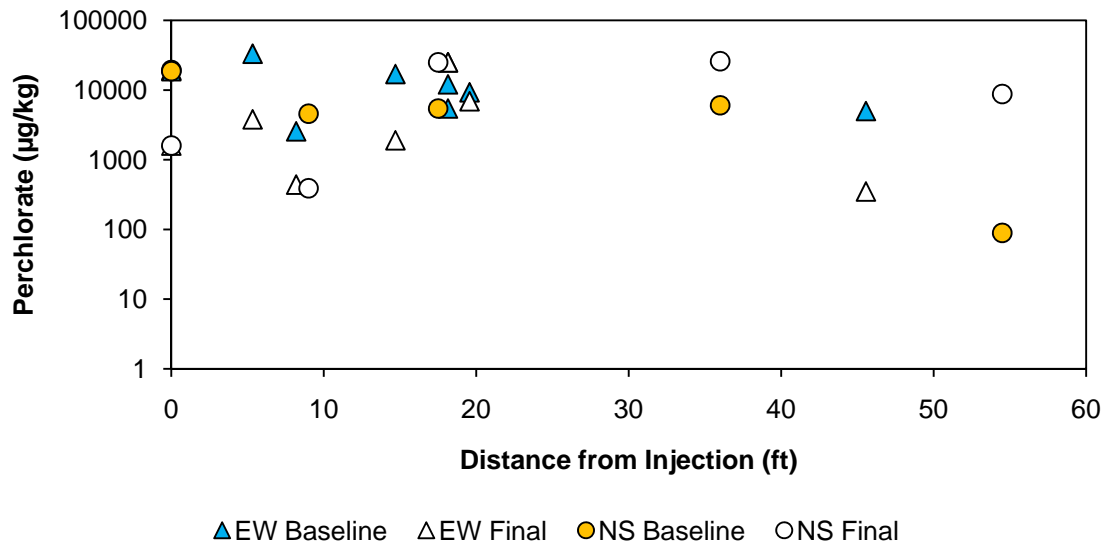

Figure 47 – Perchlorate Concentrations 35 to 40 ft bgs

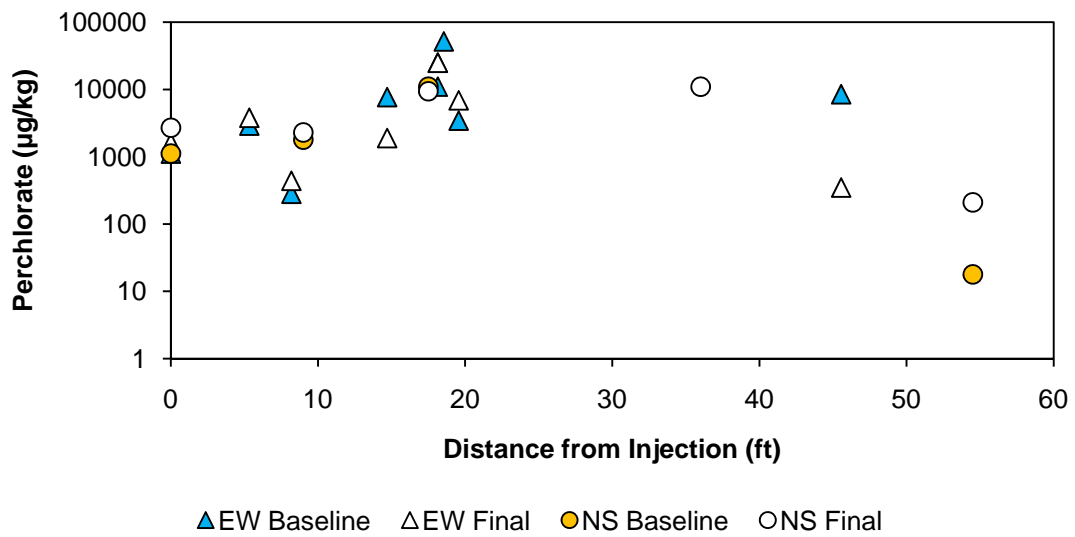

Figure 48 – Perchlorate Concentrations 45 to 50 ft bgs

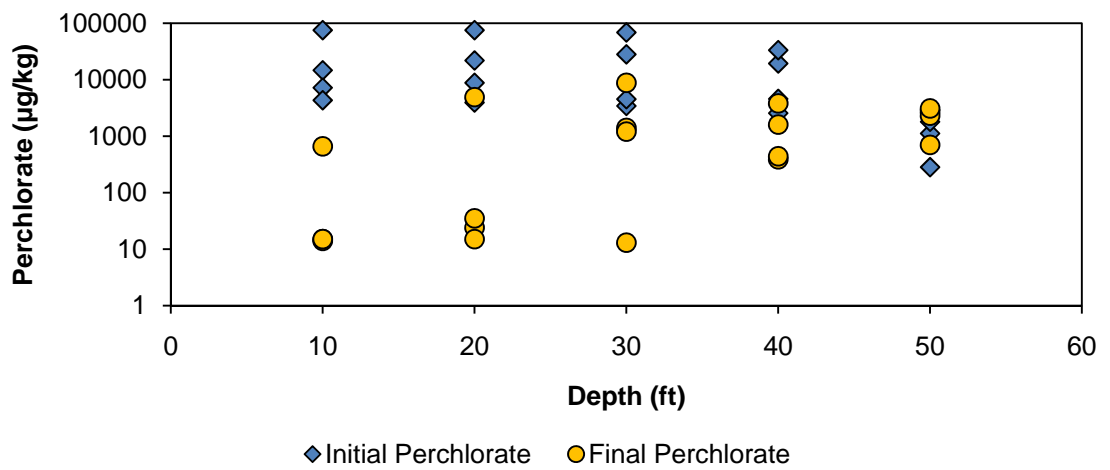
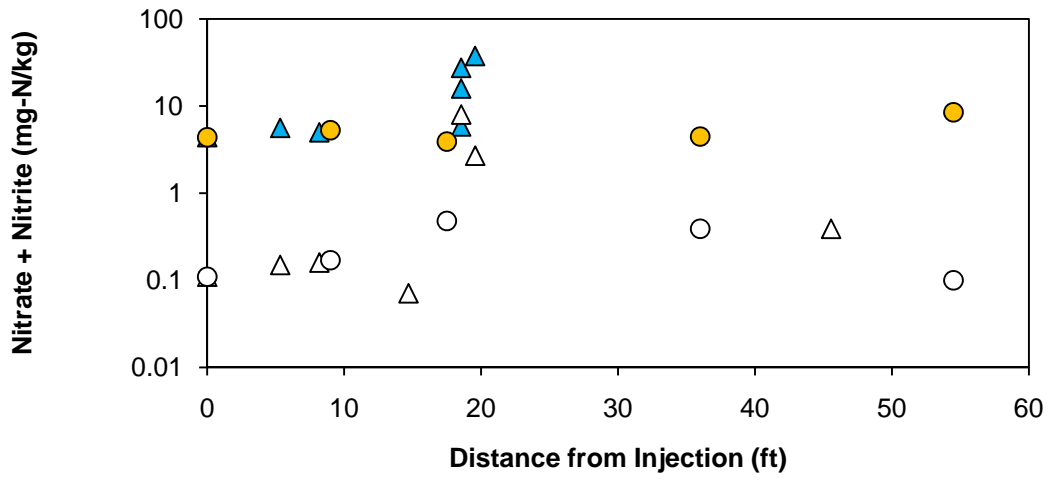
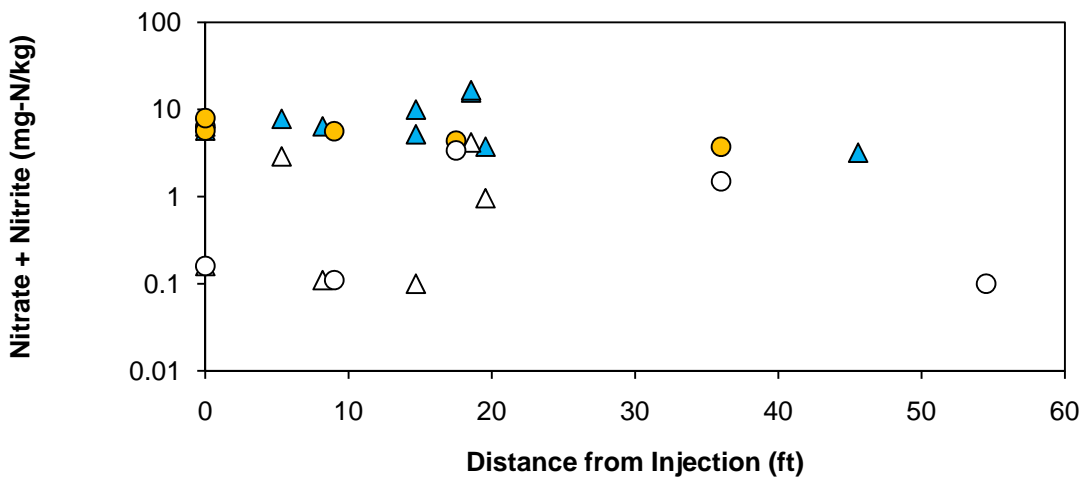

Figure 49 – Perchlorate Concentrations within the 10-ft Target ROI



▲EW Baseline △EW Final ●NW Baseline ○NW Final

Figure 50 – Nitrate/Nitrite Concentrations 5 to 10 ft bgs



▲EW Baseline △EW Final ●NS Baseline ○NS Final

Figure 51 – Nitrate/Nitrite Concentrations 15 to 20 ft bgs

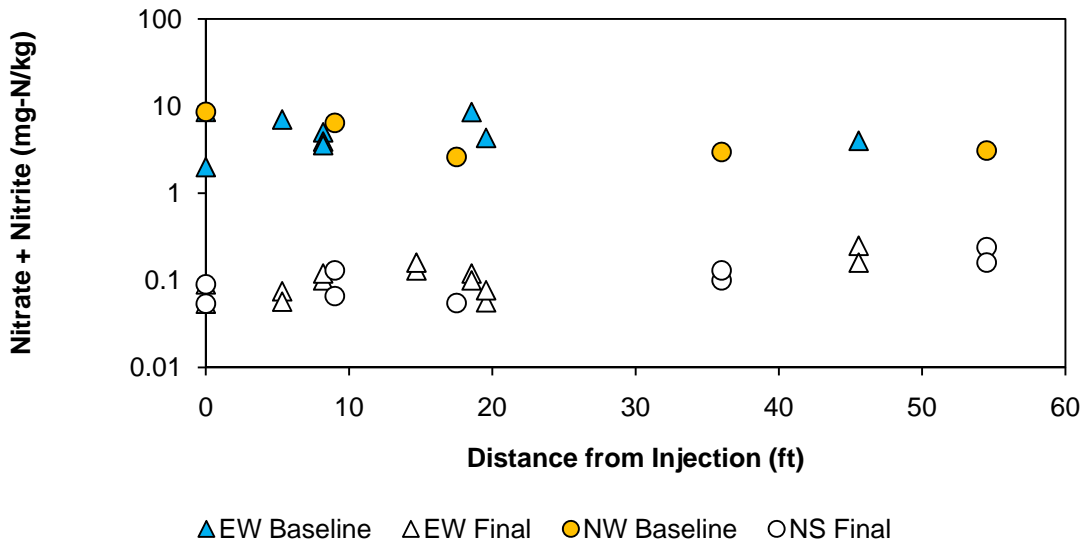

Figure 52 – Nitrate/Nitrite Concentrations 25 to 30 ft bgs

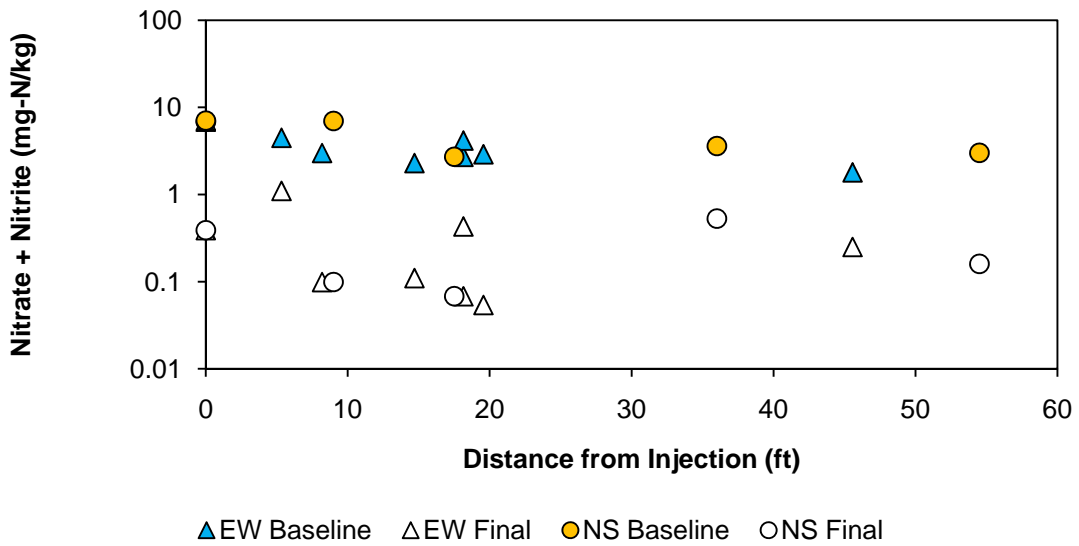

Figure 53 – Nitrate/Nitrite Concentrations 35 to 40 ft bgs

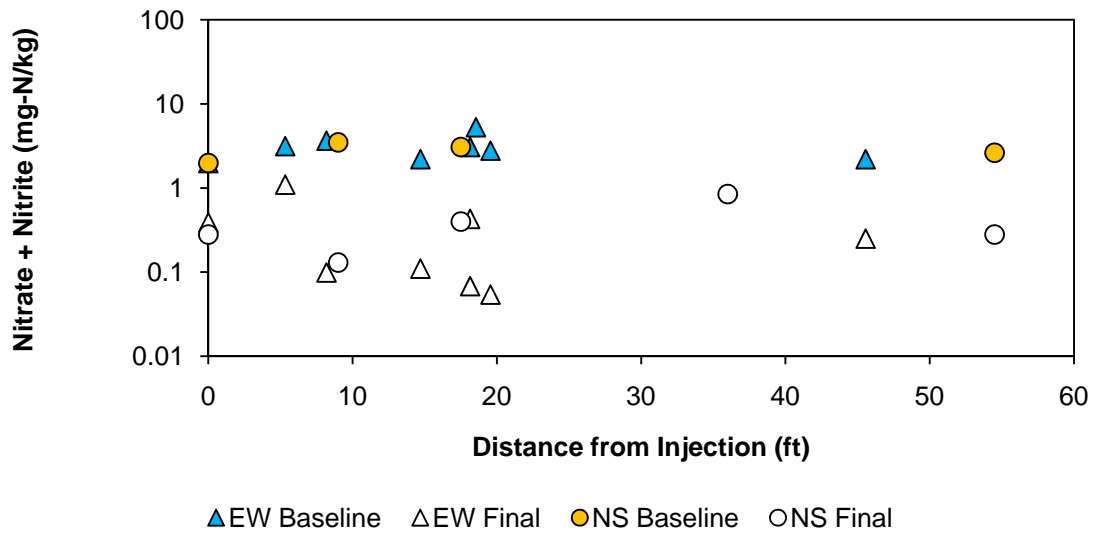

Figure 54 – Nitrate/Nitrite Concentrations 45 to 50 ft bgs

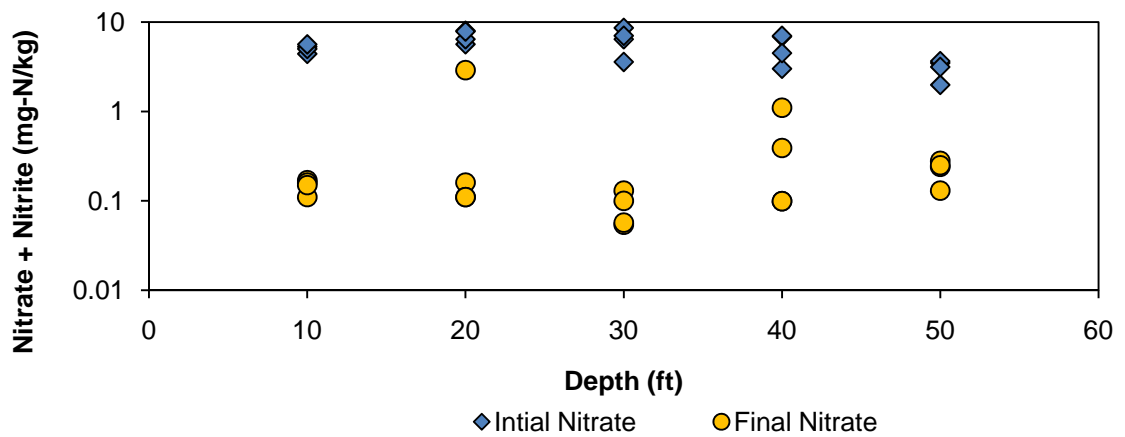

Figure 55 – Nitrate/Nitrite Concentrations within the 10-ft Target ROI

Percent perchlorate removals are shown in Figures 56 through 58. These data illustrate the dependence of perchlorate reduction on distance from the point of injection and depth below ground surface. A precipitous decline in percentage removal was observed between 15 and 20 feet from the point of injection (Figure 56). Perchlorate removal was consistently greater than 60 percent at distances less than 15 feet from the point of injection except at 50 ft bgs. At this depth perchlorate removal was inconsistent at all distances from the point of injection. Perchlorate removal was highly variable with respect to depth when the complete data set was evaluated (Figure 57) but was consistent at depths up to 40 ft bgs within the 10-ft target ROI (Figure 58). The average perchlorate removal within the 10-ft target ROI and at depths ranging from 10 to 40 ft bgs was 93 ± 9 percent.

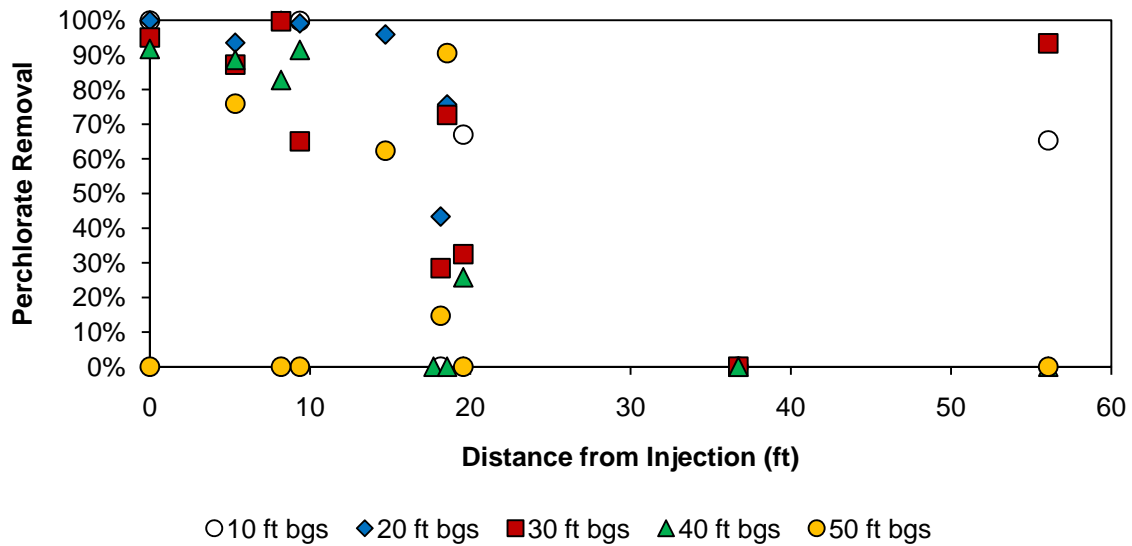

Figure 56 – Perchlorate Removal Based on All Data

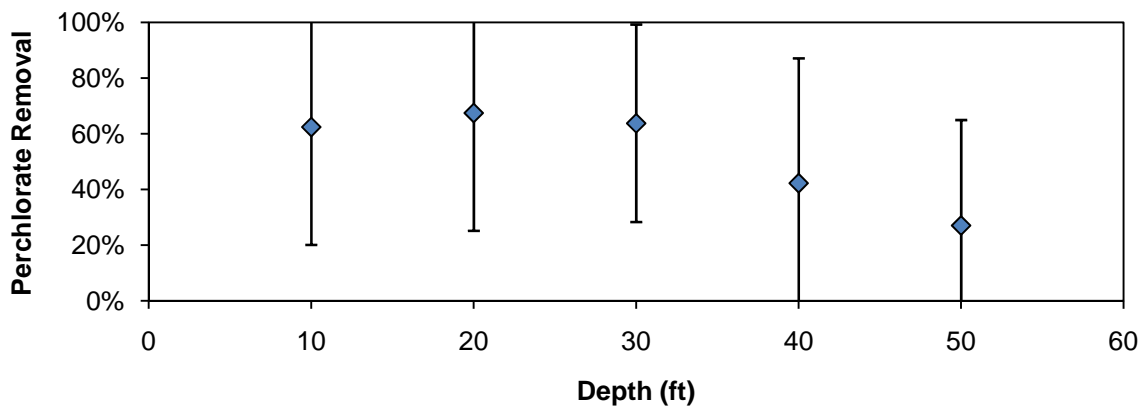

Figure 57 – Average Perchlorate Removal Based on All Data

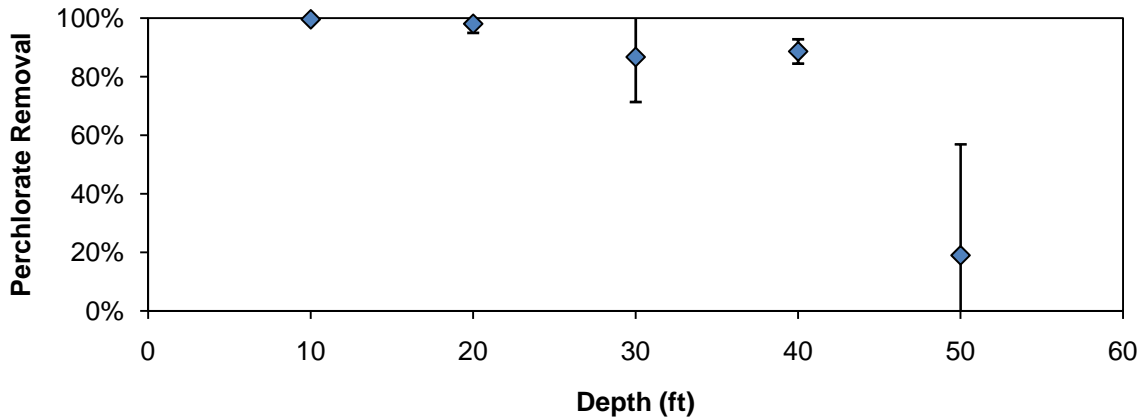

Figure 58 – Average Perchlorate Removal within the 10-ft ROI Target

Percent nitrate plus nitrite removals are shown in Figures 59 through 61. These data illustrate the relative independence of nitrate reduction on distance from the point of injection and depth below ground surface. Unlike perchlorate, nitrate removal was observed at the maximum distance sampled from the point of injection (Figure 59). Nitrate removal was consistently greater than 60 percent at all depths with the exception of 20 ft bgs. At this depth nitrate removal was inconsistent at all distances from the point of injection. Nitrate removal was generally consistent with respect to depth when the complete data set was evaluated (Figure 60) and within the 10-ft target ROI (Figure 61). The average nitrate removal within the 10-ft target ROI and at depths ranging from 10 to 50 ft bgs was 94 ± 9 percent. The average nitrate removal based on all data was 90 ± 14 percent.

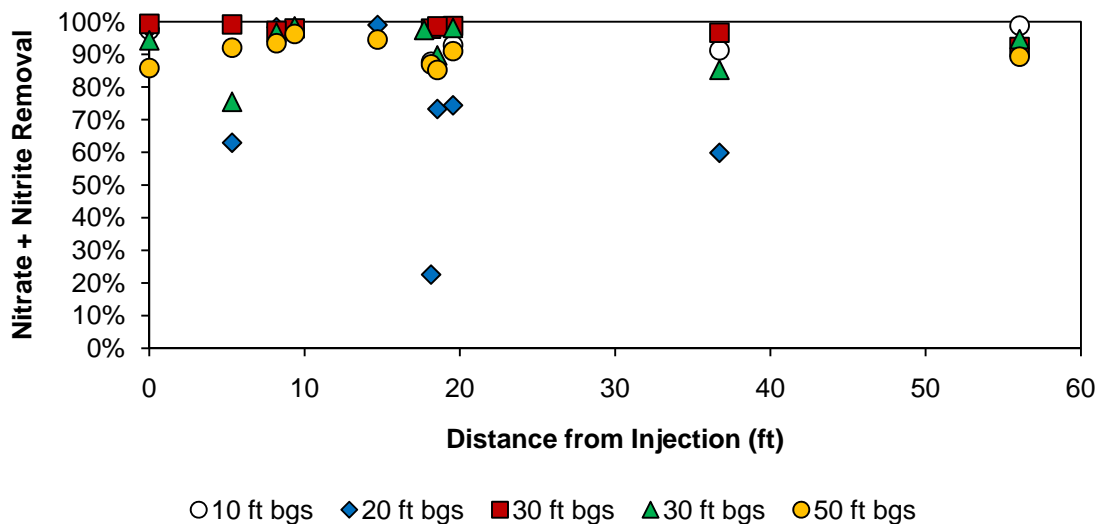

Figure 59 – Nitrate/Nitrite Removal Based on All Data

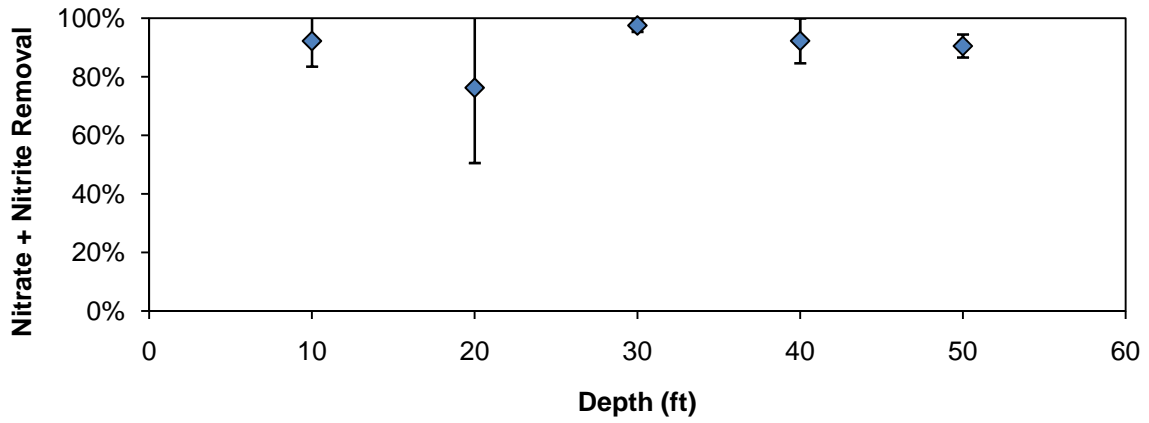

Figure 60 – Average Nitrate/Nitrite Removal Based on All Data

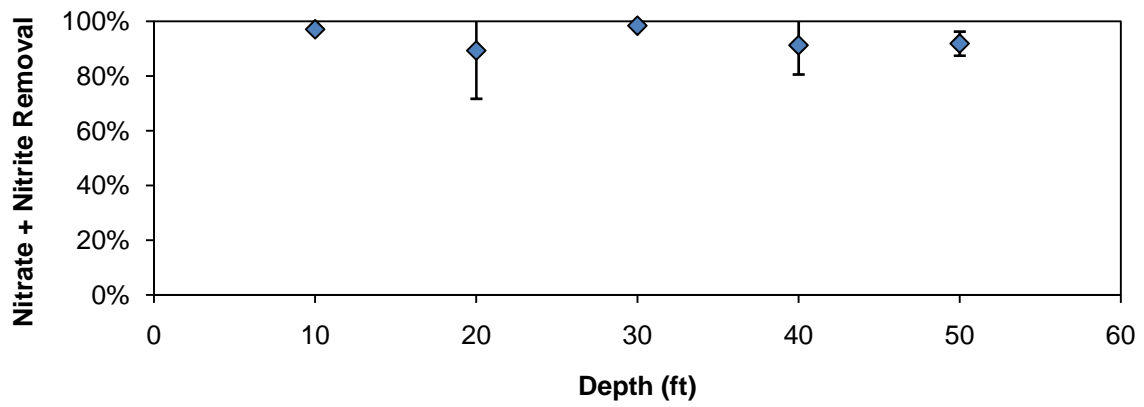

Figure 61 – Average Nitrate/Nitrite Removal within 10-ft ROI Target

5.7.5 Trends in Perchlorate and Nitrate Destruction

Continuous injection of the N₂/H₂/LPG/CO₂ gas mixture began on 3/20/08 with the initiation of Optimization Test 6 and ended on 8/12/08 for a total of five months (Figure 32 and Table 15). Continuous injection of LPG was initiated on 9/8/08 and ended on 12/1/08 for a total of three months.

The initial demonstration approach detailed in the ESTCP Technology Demonstration Plan involved periodic completion of two soil borings approximately 5 and 15 feet away from the point of injection. These soil borings were completed during the five-month period of N₂/H₂/LPG/CO₂ gas mixture injection. Evaluation of the resultant data indicated strong heterogeneity with respect to soil perchlorate concentrations as illustrated in Figures 49 and 62. Perchlorate concentrations increased dramatically from west to east in the demonstration area. Therefore, the sampling and analysis approach was modified to involve collection of additional soil borings immediately adjacent to each well and piezometer. This approach minimized the effects of heterogeneity and facilitated data analysis. These soil borings were completed following the three-month LPG injection period. The results and conclusions presented in the preceding section were based on this modified approach.

This approach did not lend itself to a detailed analysis of perchlorate degradation rates. An example of this challenge is shown in Figures 63 through 66 (see Appendix C for additional figures). These figures illustrate the trends in perchlorate and nitrate/nitrite concentrations during the demonstration. Each figure includes the baseline concentrations (P3 and P5), intermediate time points for soil borings near but not immediately adjacent to the baseline locations (CB3 and CB6), and final time points for soil borings immediately adjacent to the baseline locations (CB17 and CB15). The perchlorate and nitrate concentrations near P3 decreased during the period of N₂/H₂/LPG/CO₂ gas mixture injection (Figures 63 and 65). Assuming the initial perchlorate concentration in the vicinity of CB3 was representative of the baseline perchlorate concentration in P3, the rate of perchlorate degradation in the vicinity of P3 was 380±110 µg/kg/d over the five-month period of gas mixture injection. A nitrate destruction rate of 40±11 µg/kg/d was estimated in the vicinity of P3. Significant perchlorate reductions in the vicinity of P5 were not verified until final soil sampling was conducted at the end of Phase IV LPG injection on 12/3/08 (Figure 64). However, soil boring CB6 was completed on 7/10/08 which was one month prior to completion of Phase III gas mixture injection. As will be discussed in Section 5.7.6, hydrogen was required for perchlorate reduction. The perchlorate reduction during the three-month period of LPG injection was unlikely and perchlorate reduction probably occurred only during the five-month period of N₂/H₂/LPG/CO₂ gas mixture injection. Heterogeneity greatly complicated assessment of actual nitrate destruction rates. Nitrate reduction near P5 was observed during Phase III (Figure 66).

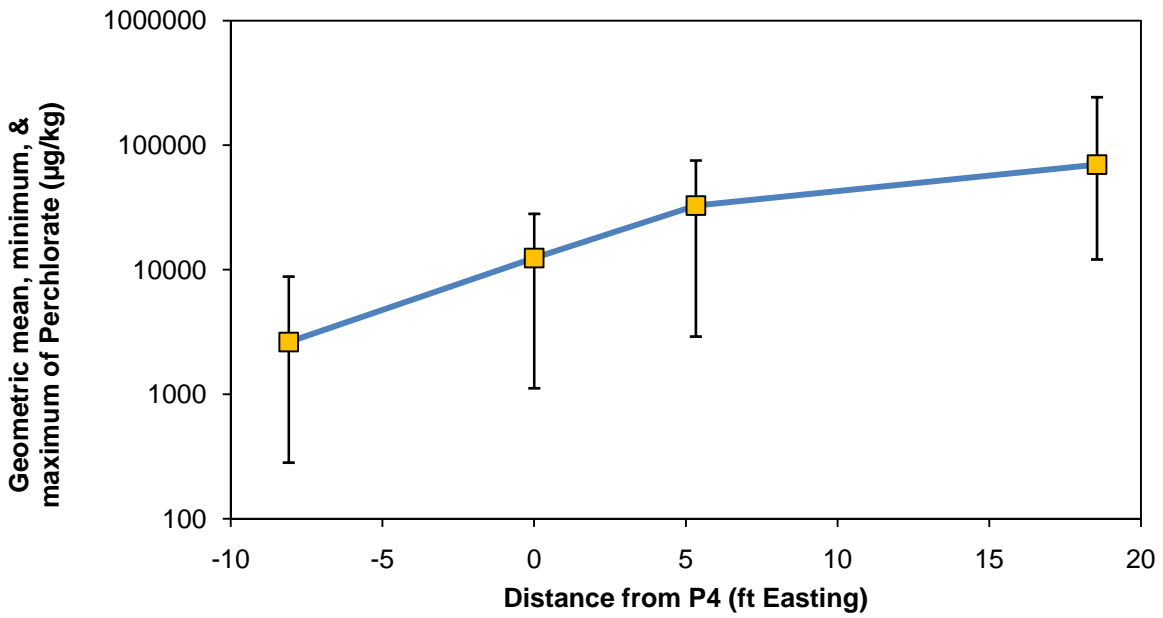

Figure 62 – Heterogeneity of Baseline Perchlorate Concentrations. Error Bars Represent Minimum and Maximum Observed Concentrations.

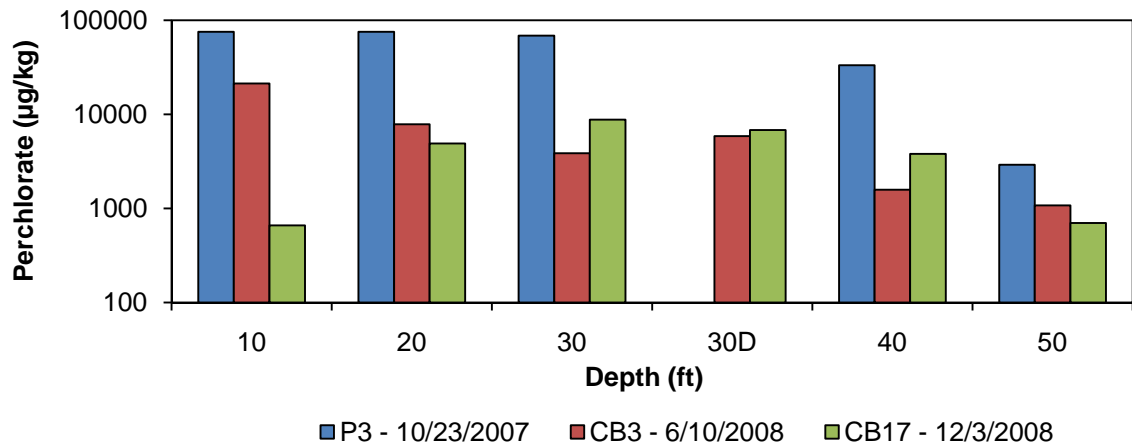

Figure 63 – Perchlorate Concentration Trends 5 ft East of the Point of Injection

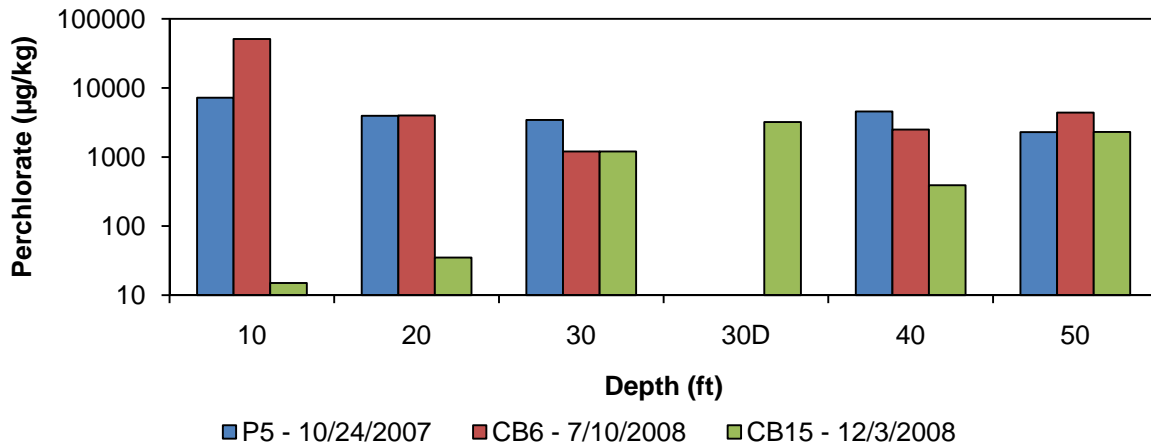

Figure 64 – Perchlorate Concentration Trends 9 ft North of the Point of Injection

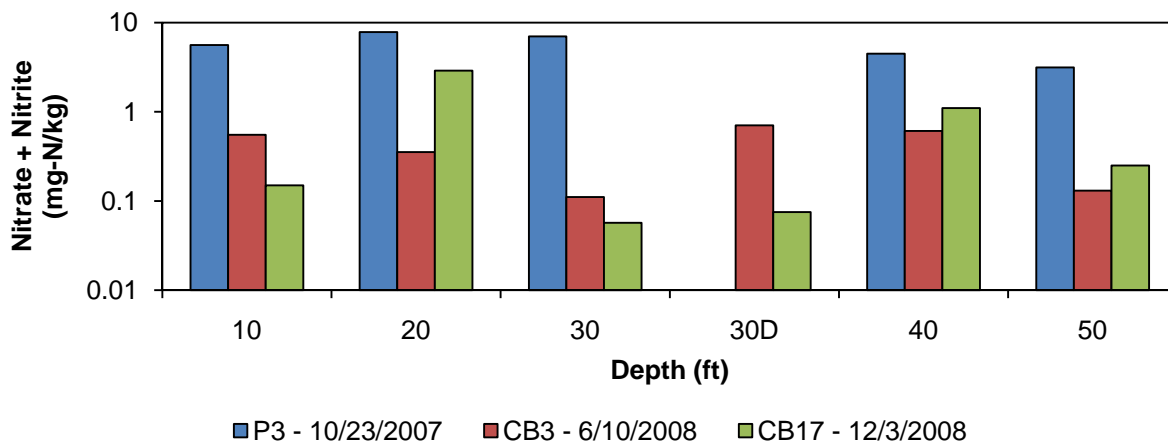

Figure 65 – Nitrate plus Nitrite Concentration Trends 5 ft East of the Point of Injection

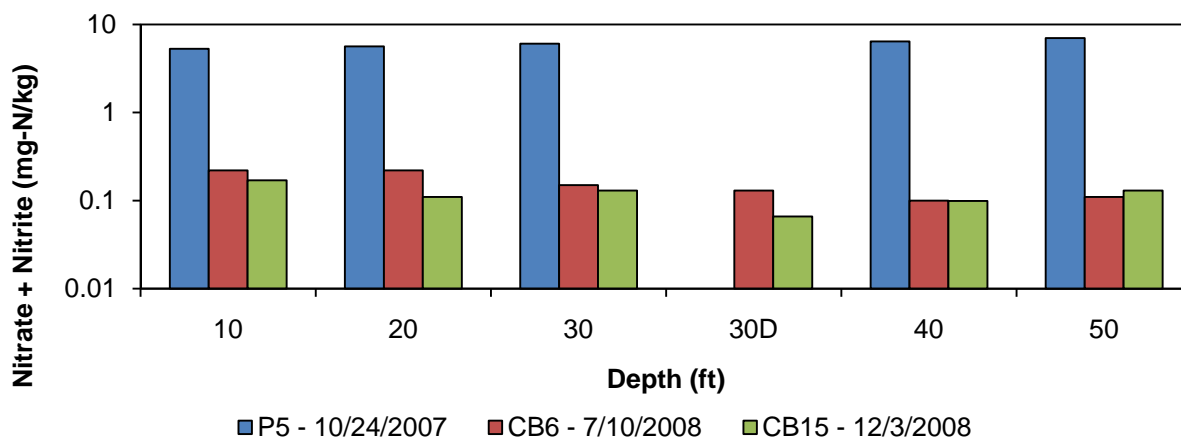

Figure 66 – Nitrate plus Nitrite Concentration Trends 9 ft North of the Point of Injection

5.7.6 Relationship between Contaminant Destruction and Gas Composition

Perchlorate reduction was high at depths of 10 to 40 ft bgs and at distances up to at least 10 ft and possibly up to 15 ft away from the point of injection (Figure 56). Perchlorate reduction was not significant at 50 ft bgs and at distances greater than 15 ft from the point of injection. The hydrogen concentration appears to be the primary factor that affected perchlorate reduction based on data presented in Figure 67 and 68. These figures illustrate the average gas concentrations and percent contaminant removal during mixed N₂/H₂/LPG/CO₂ gas and pure LPG injection, respectively.

The data in Figure 67 suggest that hydrogen and possibly oxygen may have contributed to the decline in perchlorate reduction within the 10-ft target ROI. As the depth increased from 40 to 50 ft bgs and average perchlorate reduction declined from 89±4 to 19±38 percent, average hydrogen concentration decreased from 0.61±0.77 to 0.09±0.07 percent – a decline of 85 percent. Average oxygen concentration increased insignificantly from 0.48±0.60 to 0.78±0.50 percent – an increase of 38 percent. The more significant change in hydrogen concentration relative to oxygen concentration suggests that hydrogen was the primary factor affecting perchlorate reduction. Treatability study data conclusively demonstrated perchlorate reduction in the presence of hydrogen whereas perchlorate reduction in the presence of LPG was not significantly different from the control.

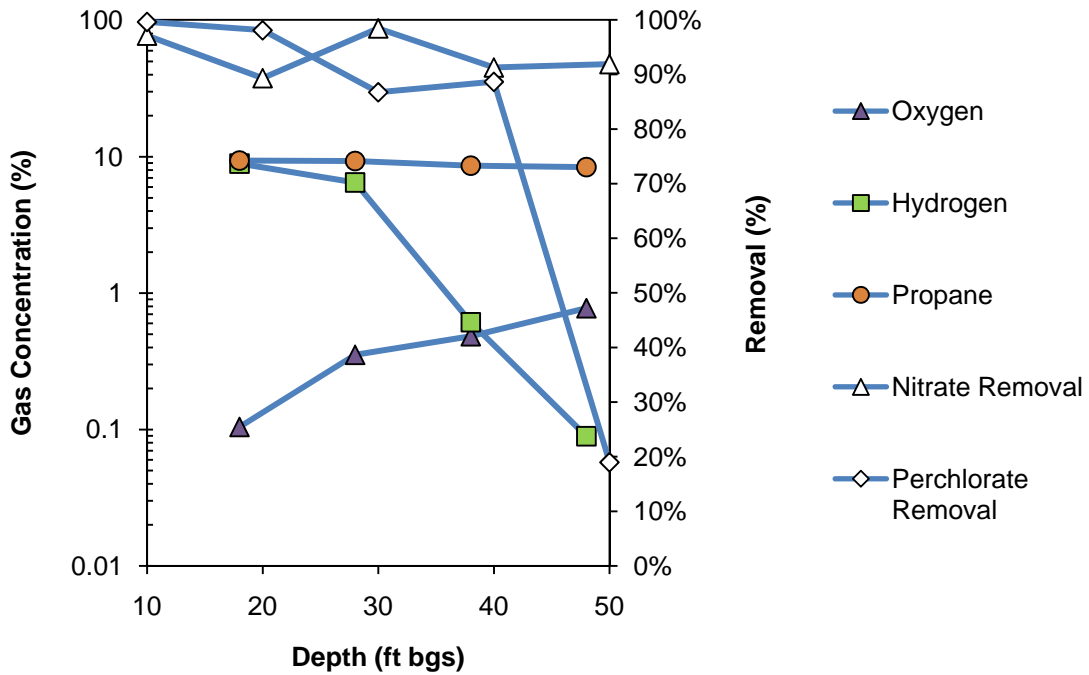

Figure 67 – Relationship between Contaminant Removal and Gas Composition within the 10-ft Target ROI during Phase III mixed N₂/H₂/LPG/CO₂ Gas Injection

Interestingly, as the depth increased from 30 to 40 ft bgs, perchlorate reduction did not change (i.e., 87±15 versus 89±4 percent), average hydrogen concentration decreased from 6.5±0.9 to 0.61±0.77 percent, and oxygen increased insignificantly from 0.35±0.82 to 0.48±0.60 percent. Thus perchlorate reduction was supported equally by 0.61±0.77 and 6.5±0.9 percent hydrogen and high hydrogen concentrations are not required to support significant perchlorate reduction. Propane did not change significantly and was not the cause of changes in perchlorate reduction. On the other hand, nitrate reduction was relatively constant suggesting that LPG supported nitrate reduction.

The data in Figure 68 support the conclusion that low hydrogen concentration was the primary factor preventing perchlorate reduction at 50 ft bgs. Hydrogen concentrations were nondetectable during LPG injection. Propane concentrations were relatively constant and oxygen concentrations were lowest at 50 ft bgs. The average oxygen concentration at 48 ft bgs during LPG injection was 0.3 ± 1.3 percent compared to 0.78 ± 0.50 percent during mixed gas injection. The average LPG concentration at 48-ft bgs was 28 ± 3 percent². Still, no perchlorate reduction occurred at this depth. Thus hydrogen supplied during Phase III was required for perchlorate reduction.

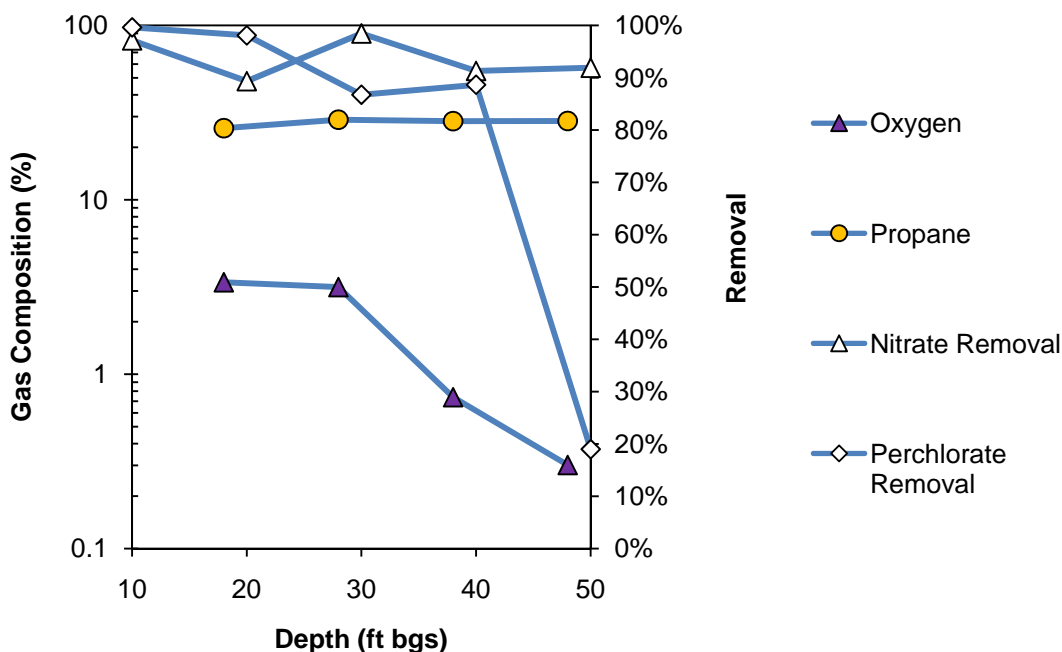

Figure 68 – Relationship between Contaminant Removal and Gas Composition within the 10-ft Target ROI during Phase IV LPG Injection

While hydrogen appears to have been the primary factor affecting perchlorate reduction within the 10-ft target ROI, oxygen appears to have prevented perchlorate reduction outside of this zone especially at distances greater than 15 ft from the point of injection.

Figure 69 illustrates that when all of the data are evaluated (i.e., inside and outside the 10-ft target ROI and at all depths), the oxygen concentration increased in a roughly exponential manner as the distance from the point of injection increases ($r^2 = 0.56$). Significant perchlorate reduction was observed when the oxygen concentration was less than about one percent. Perchlorate reduction was negligible or inconsistent when oxygen concentrations were greater than about one percent. Very low oxygen concentrations (e.g., less than 0.1 percent) were not

² The RKI Eagle had a maximum reporting level of 30 percent for propane. Therefore this value should be considered a minimum value.

required for significant perchlorate reduction. Hydrogen concentration decreased with distance from the point of injection as illustrated in Figure 70, but the correlation coefficient was low ($r^2 = 0.14$). Even though hydrogen concentrations near one percent were observed at distances greater than 20 feet from the point of injection (Figure 70), consistent perchlorate removal was not observed because of elevated oxygen concentrations (Figure 69). When the data presented in Figures 67 through 70 along with additional data presented in Section 5.7.3 are considered, the required conditions for perchlorate reduction at this site appear to be less than one percent oxygen and greater than 0.2 percent hydrogen.

Figure 71 indicates that nitrate reduction was not nearly as sensitive to oxygen inhibition as perchlorate reduction and significant nitrate reduction was observed with oxygen concentrations up to 10 percent or greater. Figures 72 and 73 indicate that hydrogen concentrations as low as about 0.01 percent and/or propane concentrations about three percent or greater supported nitrate reduction.

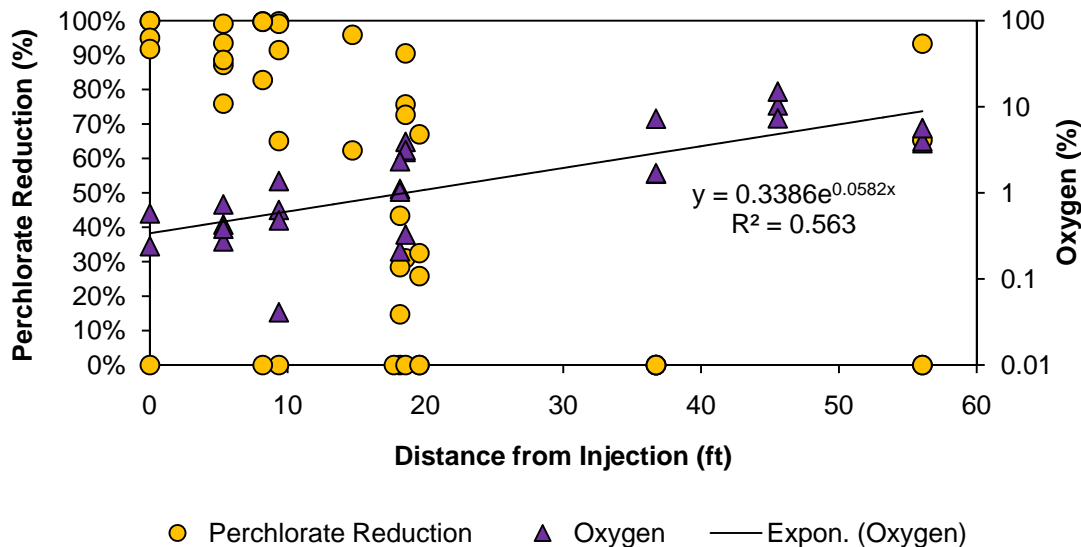

Figure 69 – Relationship between Perchlorate Reduction and Oxygen Concentration Inside and Outside the 10-ft Target ROI during Phase III Mixed N₂/H₂/LPG/CO₂ Gas Injection

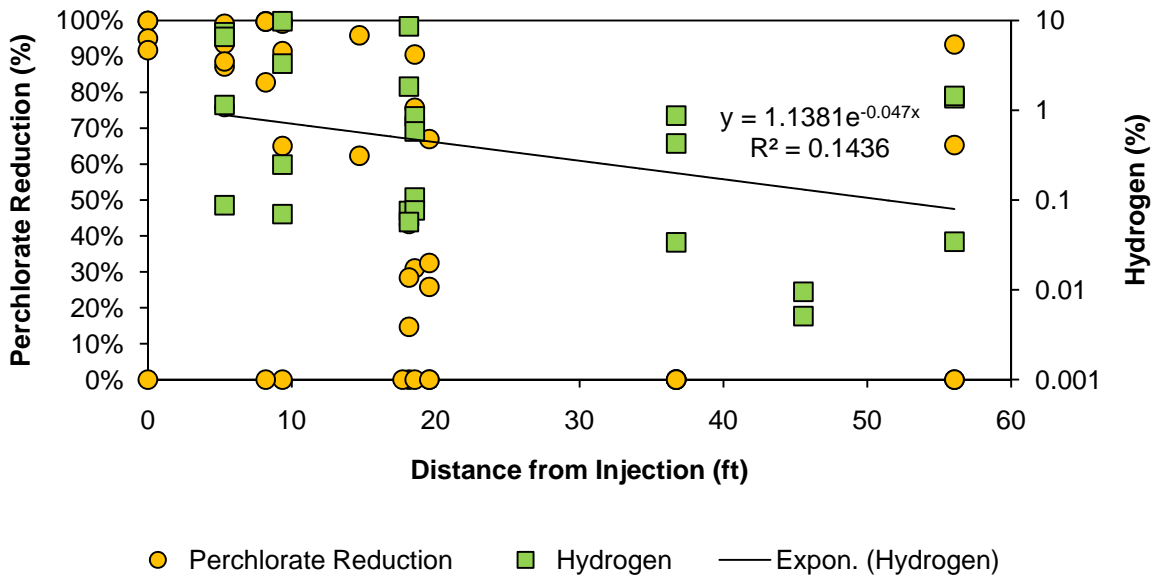

Figure 70 – Relationship between Perchlorate Reduction and Hydrogen Concentration Inside and Outside the 10-ft Target ROI during Phase III Mixed N₂/H₂/LPG/CO₂ Gas Injection

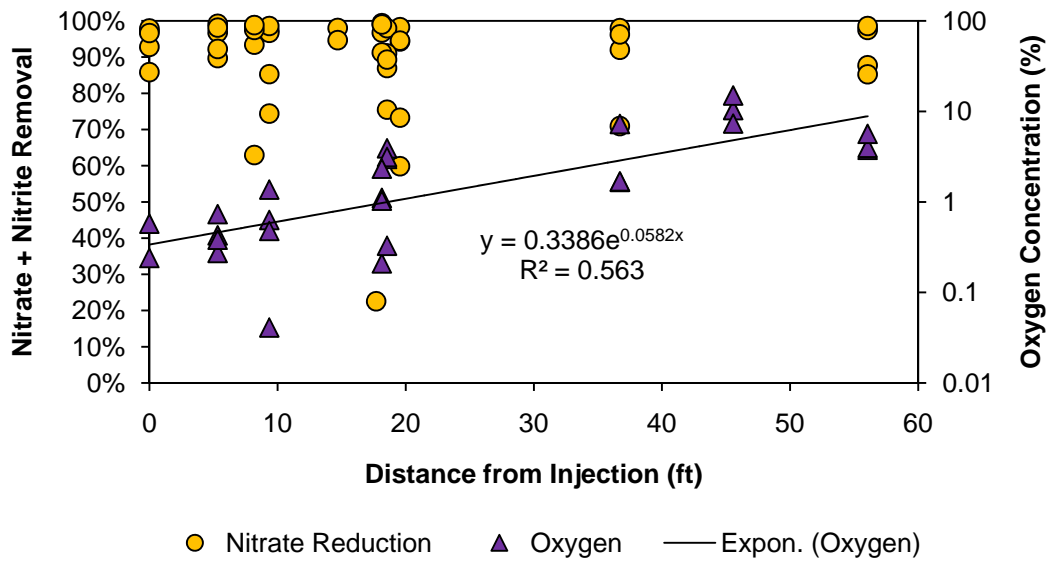

Figure 71 – Relationship between Nitrate Reduction and Oxygen Concentration Inside and Outside the 10-ft Target ROI during Phase III Mixed N₂/H₂/LPG/CO₂ Gas Injection

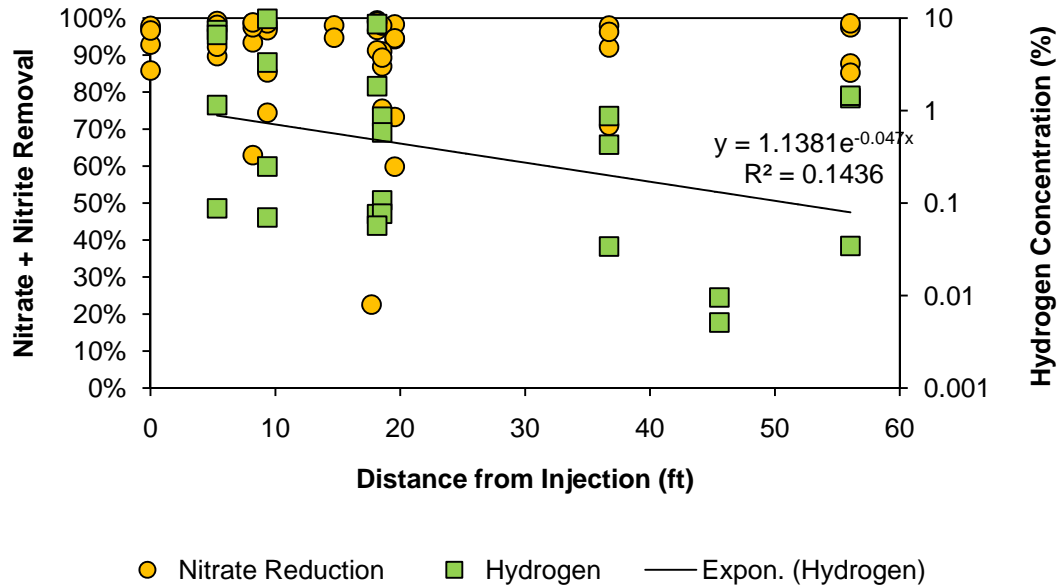

Figure 72 – Relationship between Nitrate Reduction and Hydrogen Concentration Inside and Outside the 10-ft Target ROI during Phase III Mixed N₂/H₂/LPG/CO₂ Gas Injection

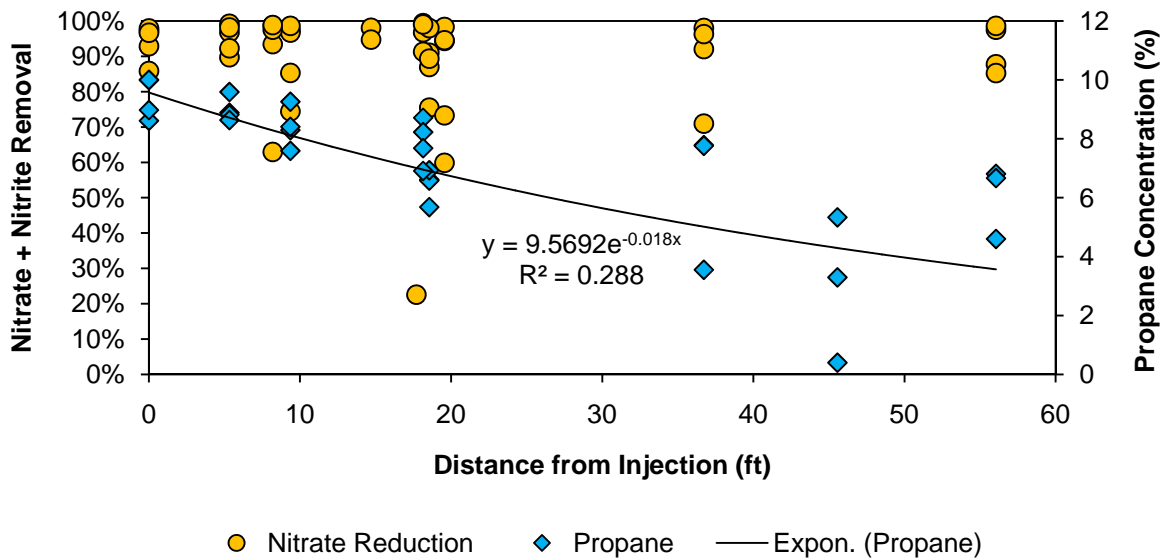

Figure 73 – Relationship between Nitrate Reduction and Propane Concentration Inside and Outside the 10-ft Target ROI during Phase III Mixed N₂/H₂/LPG/CO₂ Gas Injection

5.7.7 Soil Moisture Effects

In addition to gas composition, perchlorate biodegradation can be influenced by soil moisture in two ways. One is with respect to biological activity and the other is with respect to gas transport. If soil moisture is too low then biological activity could be inhibited. Treatability tests conducted using site soil demonstrated that perchlorate reduction was possible with 16 percent moisture but not with eight percent moisture. Additionally, if soil moisture is very high, for example in clay, then gas transport may be hindered and insufficient electron donors will be available to promote perchlorate biodegradation. Figure 74 illustrates that a wide range of soil moistures were measured and these variations were attributable to variations in soil lithologic conditions. In general, shallower soils (e.g., 10 to 20 ft bgs) were predominately clays and silts and deeper soils (e.g., 30, 40, and 50 ft bgs) were predominately silty sands and gravels. Perchlorate degradation was observed less than 15 ft from the point of injection and at depths of 10 to 40 ft bgs (Figure 56). Initial moisture contents in this zone ranged from 10 to 36 percent as shown on Figure 75. Initial moisture contents ranged from 6.1 to 36 percent (Figure 76). Thus perchlorate biodegradation was observed at moisture contents as low as 6.8 to 10 percent which is less than that observed in the treatability study. Thus field performance was better than laboratory treatability performance. At this site, moisture content did not control perchlorate removal based on a lack of correlation with moisture content within the 10-ft target ROI and across the entire demonstration area (Figures 75 through 78). Nitrate removal was not affected by moisture content and significant removal was observed at moisture contents as low as 6.1 percent (Figures 79 and 80).

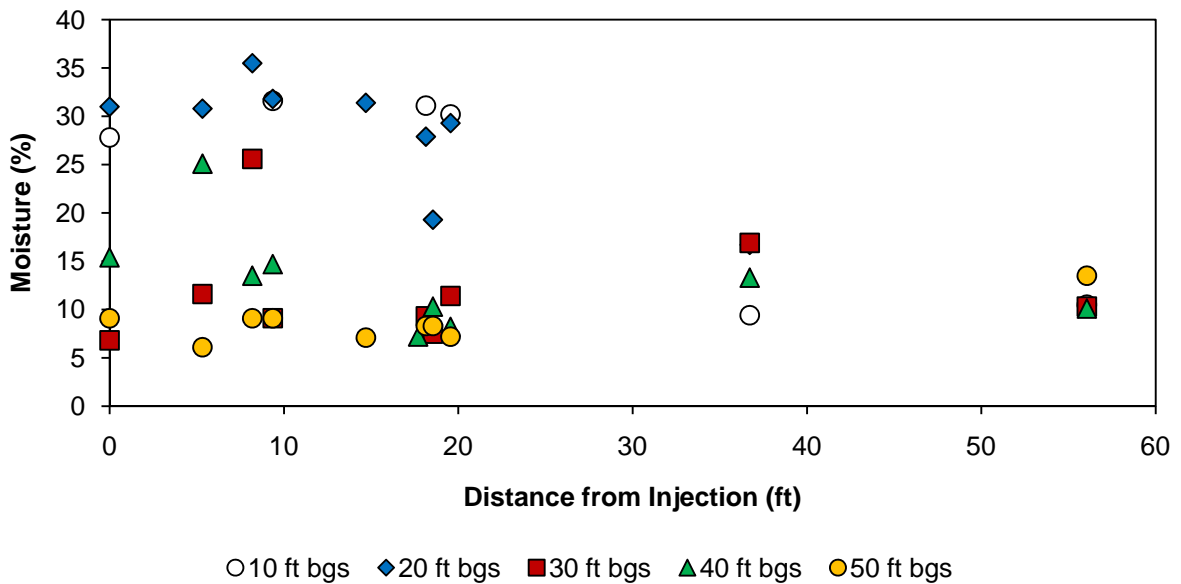

Figure 74 – Final Moisture Distribution

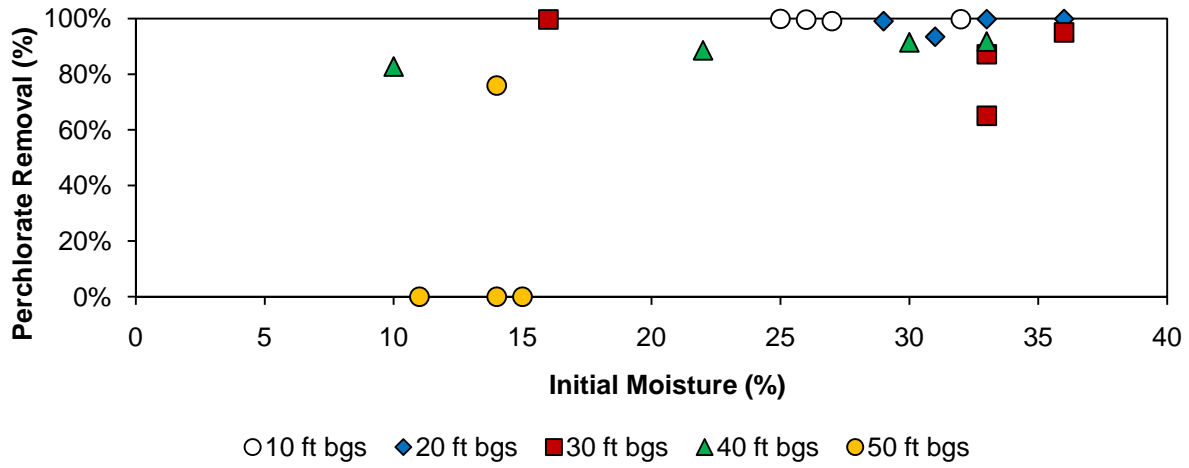

Figure 75 – Perchlorate Removal within the 10-ft Target ROI at Different Initial Moisture Contents

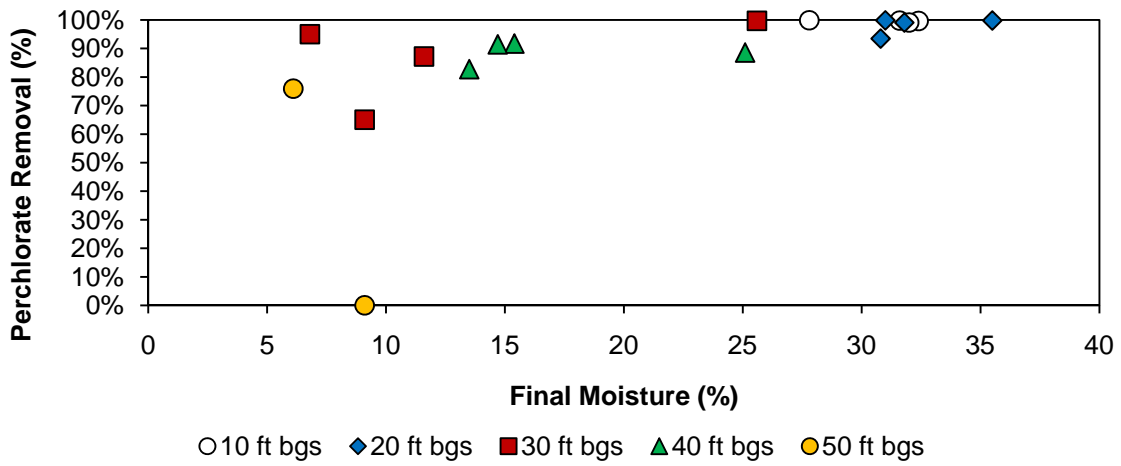

Figure 76 – Perchlorate Removal within the 10-ft Target ROI at Different Final Moisture Contents

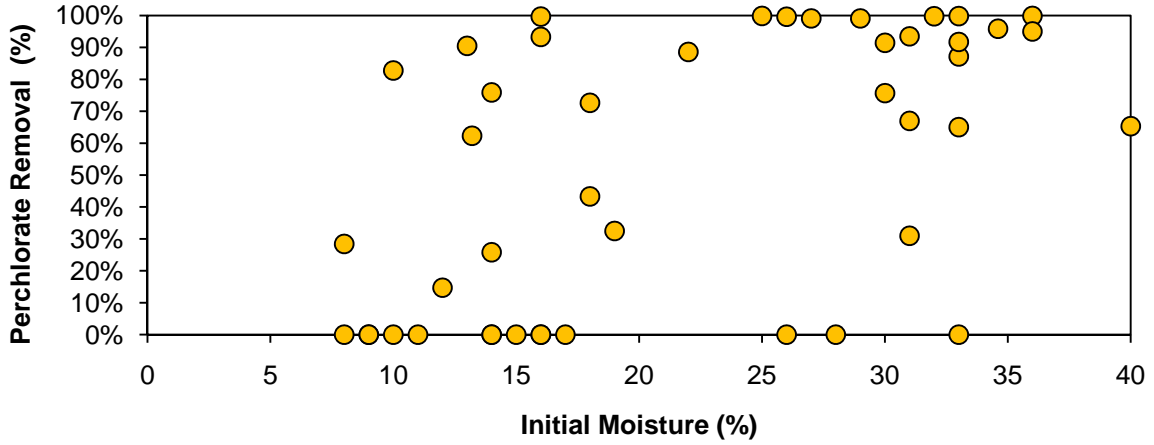

Figure 77 – Perchlorate Removal Inside and Outside the 10-ft Target ROI at Different Initial Moisture Contents

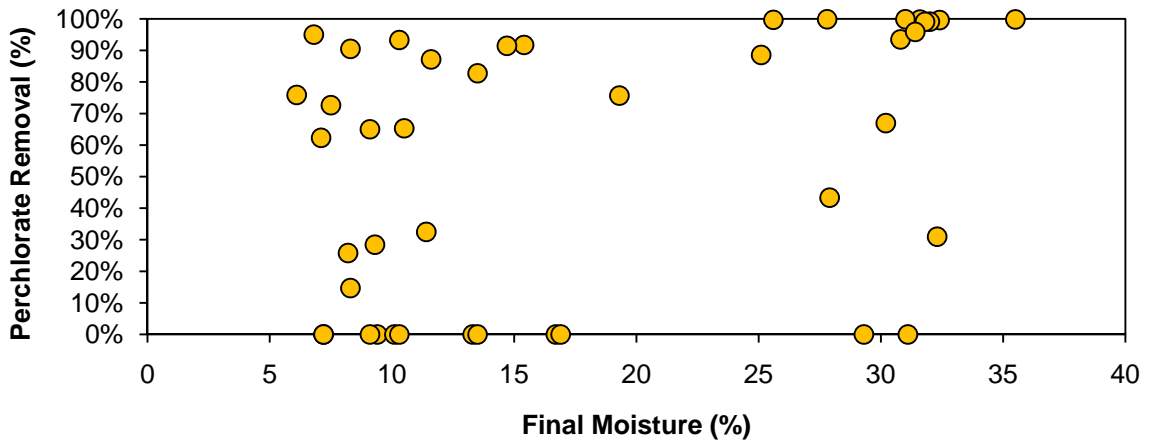

Figure 78 – Perchlorate Removal Inside and Outside the 10-ft Target ROI at Different Final Moisture Contents

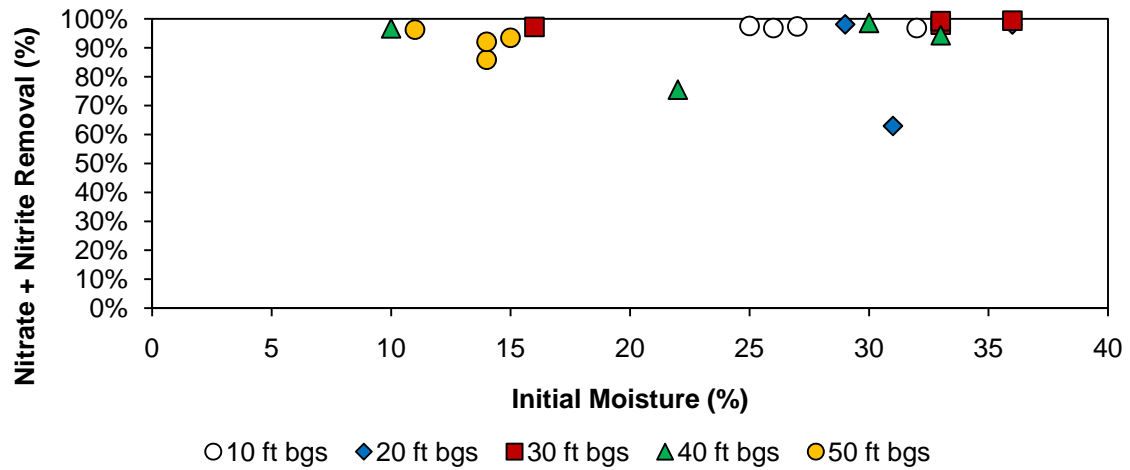

Figure 79 – Nitrate Removal within the 10-ft Target ROI at Different Initial Moisture Contents

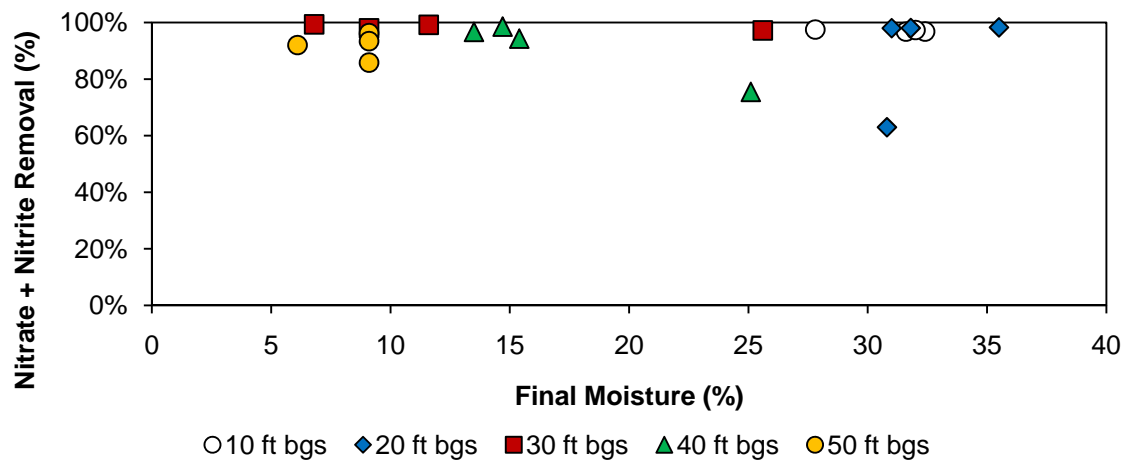

Figure 80 – Nitrate Removal within the 10-ft Target ROI at Different Final Moisture Contents

The potential for soil drying because of dry gas injection was evaluated. Figures 81 and 82 indicate that changes in soil moisture were highly variable. The average change in soil moisture was an 18 percent decrease which was statistically significant ($P=0.0098$). Soil drying appeared to be especially significant in the immediate vicinity of the point of injection. Soil drying is typically expected in the immediate vicinity of gas injection (Leeson and Hinchee, 1996). Thus the observed soil drying was not necessarily attributable to GEDIT and may have been attributable to seasonal variation of rainwater infiltration. Nevertheless, this drying did not result in bone-dry soil that could have inhibited perchlorate biodegradation.

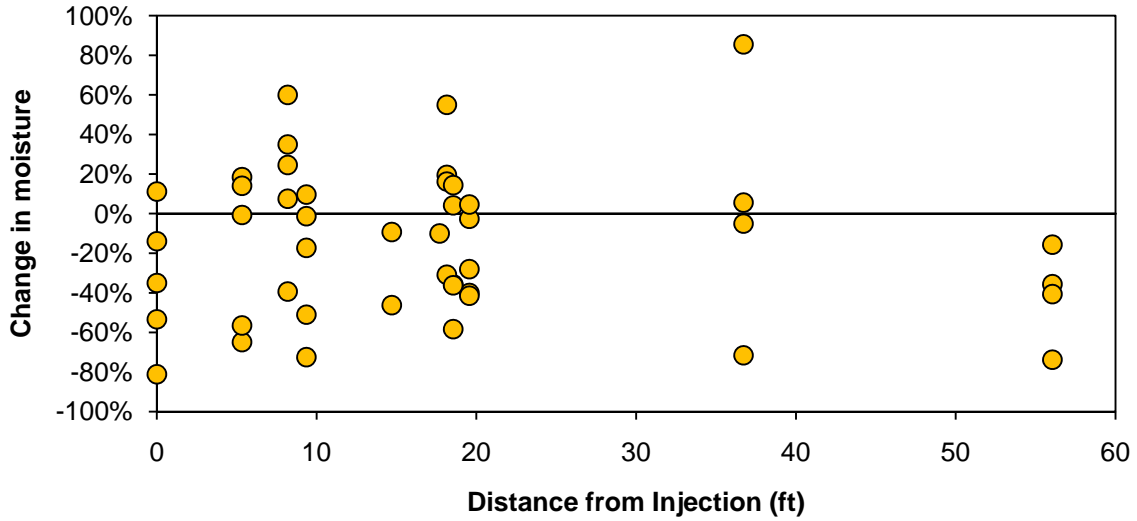

Figure 81 – Change in Moisture as a Function of Distance from the Point of Injection

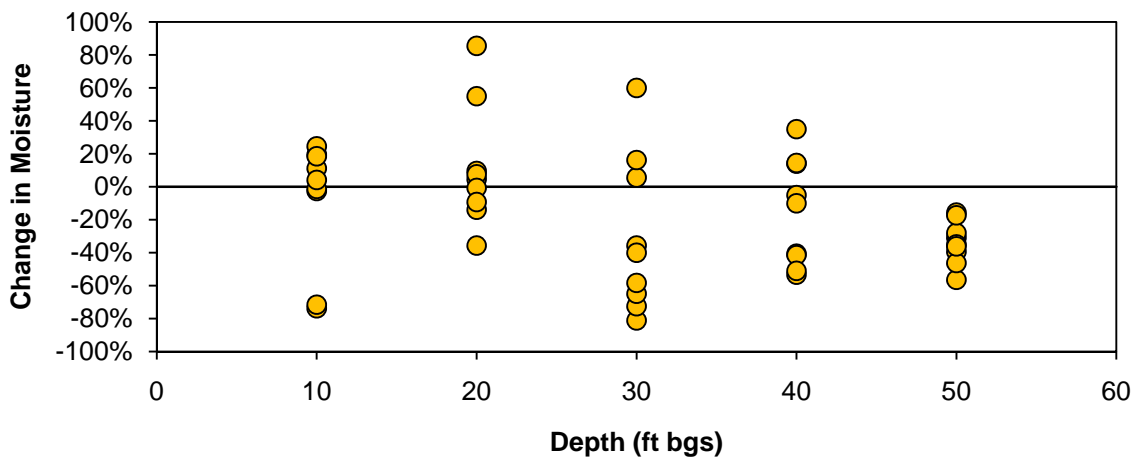

Figure 82 – Change in Moisture as a Function of Depth

5.7.8 Soil Lithology Effects

Perchlorate destruction was observed across a wide range of moisture contents. These moisture contents in general correlated with soil lithologic conditions – finer grained soil types (e.g., clays and silts) had greater moisture contents than larger grained soil types (e.g, sands and gravels). Figures 83 and 84 illustrate that higher perchlorate destruction was observed across a wide range of soil lithologic conditions. The data in these figures are based on samples collected within the 10-ft target ROI and depths from 10 to 40 ft bgs. A qualitative assessment of permeability was based on USCS³ soil types. Most samples upon which perchlorate destruction was quantified were fine-grained, low-permeability USCS soil type (e.g., CL). High perchlorate destruction was also observed in coarse-grained, high-permeability soil types.

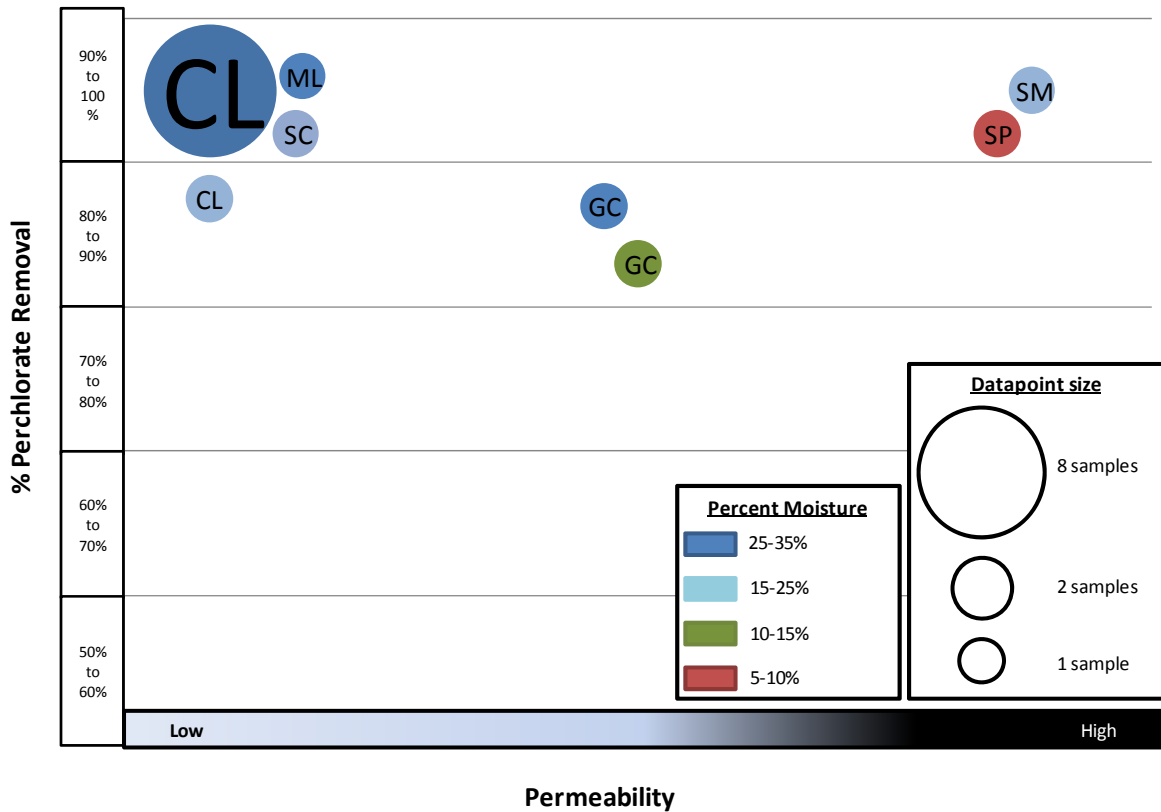

Figure 83 – Relationship between Perchlorate Destruction and Baseline Soil Moisture and USCS Soil Type

³ Unified Soil Classification System definitions used in Figures 83 and 84 are as follows: CL – clay; ML – silt; SC – clayey sand; GC – clayey gravel; GM – silty gravel; GW – well graded gravel; SP – poorly graded sand; SM – silty sand.

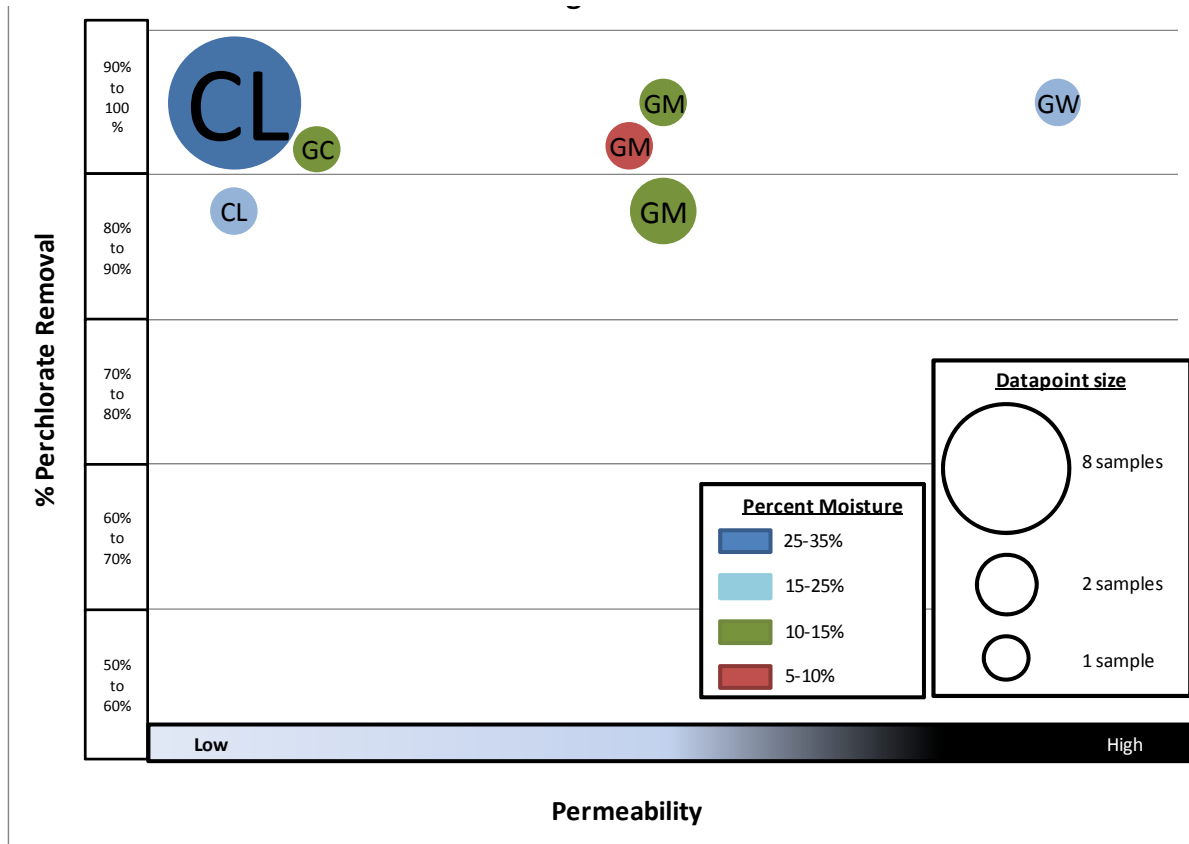

Figure 84 – Relationship between Perchlorate Destruction and Final Soil Moisture and USCS Soil Type

6.0 PERFORMANCE ASSESSMENT

A summary of the performance objectives for this demonstration along with an overview of technology performance was presented in Section 3. This section includes an assessment of technology performance that is supported by data presented in Section 5.

6.1 Perchlorate Destruction

The average percent perchlorate destruction was 93 ± 9 percent within the 10-ft radius of influence and the 10-to-40-ft bgs depth interval (see Section 5.7.4). This ROI and depth interval was based on hydrogen transport and oxygen concentrations as described in Section 6.5. The performance objective of 90 percent for perchlorate destruction was exceeded. Initial perchlorate concentrations within this ROI and depth ranged from 2,600 to 75,000 $\mu\text{g}/\text{kg}$. Final perchlorate concentrations ranged from < 13 to 8,800 $\mu\text{g}/\text{kg}$. Seven final soil samples (i.e., six sample locations plus one duplicate) were ND for perchlorate (< 13 to < 15 $\mu\text{g}/\text{kg}$).

Perchlorate destruction was affected by oxygen and hydrogen concentrations (see Section 5.7.6). As illustrated in Figure 67, oxygen concentrations less than about one percent and hydrogen concentrations greater than 0.5 percent supported perchlorate destruction. These concentrations were observed within the 10-ft ROI and 40-ft bgs depth. At greater distances from the point of injection (i.e., P4) and greater depths, the oxygen concentrations were greater than one percent and/or the hydrogen concentrations were less than 0.5 percent.

Perchlorate destruction did not appear to be promoted by LPG serving as an electron donor for anaerobic perchlorate biodegradation (see Section 5.7.6). During the three-month Phase IV LPG/N₂ injection, oxygen concentrations at 48-ft bgs were 0.3 ± 1.3 percent and average LPG concentrations were 28 ± 3 percent though insignificant perchlorate reduction was observed at 50 ft bgs (Figure 68). While LPG did not directly promote perchlorate biodegradation, it is capable of serving as an electron donor for aerobic bacteria. Therefore, it may have indirectly promoted perchlorate biodegradation during the five-month Phase III injection of H₂/CO₂/LPG/N₂ by reducing oxygen concentrations via aerobic propane biodegradation.

Perchlorate destruction was not affected strongly by differences in soil moisture at this site (see Section 5.7.7). Significant perchlorate destruction was observed in soil samples with final moisture contents ranging from 6.8 to 36 percent (Figure 75). Too low of a moisture content has the potential to inhibit perchlorate biodegradation. Some inhibition may have occurred at low moisture contents compared to high moisture contents, but 95 percent perchlorate destruction was observed at a moisture content of 6.8 percent. Laboratory treatability data demonstrated perchlorate biodegradation at 16 percent moisture but not at 7 percent moisture. Thus perchlorate destruction performance in the field was greater than predicted by the laboratory treatability study. High moisture contents were representative of silt and clay soil types. These soil types would be expected to hinder electron donor transport. However, high perchlorate destruction was observed at the highest moisture contents indicating that hydrogen was able to diffuse into low permeability soil pore spaces. Hydrogen with a molecular weight of two has a high diffusivity relative to other gases. For example, the diffusivities of hydrogen and oxygen (molecular weight of 32) in air are 0.611 and 0.178 cm^2/s , respectively (Perry and Chilton, 1973). The diffusivities

of hydrogen and oxygen in water are 5.85×10^{-5} and 2.5×10^{-5} cm²/s, respectively (Perry and Chilton, 1973).

Perchlorate destruction was not affected by differences in soil lithologic conditions associated differences in pneumatic permeability (Section 5.7.8 and Figures 83 and 84).

6.2 Nitrate Destruction

The average percent nitrate destruction was 94 ± 9 percent within the 10-ft radius of influence and the 10-to-50-ft bgs depth interval (see Section 5.7.4). This ROI and depth interval was based on hydrogen and LPG transport and oxygen concentrations as described in Section 6.5. The performance objective of 90 percent for perchlorate destruction was exceeded. When all data were considered which comprised an ROI of 56 ft, the average nitrate destruction was 90 ± 14 percent. Nitrate was analytically quantified as the sum of nitrate and nitrite. Therefore, accumulation of the denitrification intermediate nitrite did not occur. Initial concentrations of nitrate plus nitrite within the 10-ft target ROI ranged from 2.0 to 8.6 mg-N/kg. Final nitrate plus nitrite concentrations ranged from < 0.054 to 2.9 mg-N/kg. Six final soil samples (i.e., five sample locations plus one duplicate) were ND for nitrate plus nitrite (< 0.054 to < 0.057 mg-N/kg).

Nitrate destruction was affected less by gas composition than perchlorate destruction (see Section 5.7.6). Significant nitrate destruction occurred when oxygen concentrations were less than about 10 percent (Figure 71). Nitrate destruction was observed under a wide range of hydrogen concentrations as low as about 0.01 percent and under propane concentrations about three percent or greater (Figures 72 and 73). Whether hydrogen or propane was predominant electron donor for nitrate biodegradation cannot be ascertained based on these data. Also, naturally occurring organic carbon could have served as an electron donor. Data from the Remedial Investigation indicated that total organic carbon in soil was generally ND at reporting limits ranging from 105 to 132 mg/kg. Although, one soil sample contained 3,210 mg/kg of TOC (Aerojet & HSI GeoTrans, 2000).

Similar to perchlorate, nitrate destruction was not affected by differences in soil moisture at this Site (Section 5.7.7 and Figures 79 and 80).

6.3 Perchlorate Destruction Rate

A maximum of five months was required to achieve 93 ± 9 percent perchlorate destruction during the demonstration and three months or less was required in certain locations (Section 5.7.5). The performance objective was 90 percent destruction within twelve months. Thus, the performance objective was met. Heterogeneity greatly complicated assessment of actual perchlorate destruction rates. Nevertheless, 88 ± 11 percent perchlorate destruction at a rate of 380 ± 110 µg/kg/d was estimated in the vicinity of P3. This rate compares favorably to biodegradation rates measured during optimized full-scale *ex situ* bioremediation of perchlorate in soil (Evans et al., 2008). There, the median rate was about 200 µg/kg/d and the 90th percentile rate was about 500 µg/kg/d.

6.4 Nitrate Destruction Rate

A maximum of five months was required to achieve 94 ± 9 percent nitrate destruction during the demonstration and three months or less was required in certain locations (Section 5.7.5). The performance objective was 90 percent destruction within six months. Thus, the performance objective was met. Nitrate plus nitrite was quantified to account for the potential of nitrite accumulation during denitrification. Therefore the destruction rate is representative of nitrate and nitrite destruction rather than partial nitrate transformation to nitrite. Heterogeneity greatly complicated assessment of actual nitrate destruction rates. Nevertheless, a nitrate destruction rate of 40 ± 11 $\mu\text{g}/\text{kg}/\text{d}$ was estimated in the vicinity of P3.

6.5 Implementability

ROI was used as a primary metric for implementability because it will determine the number of wells required to treat a given area. The ROI for perchlorate degradation was conservatively estimated to be 10 feet and likely to be 15 ft during the demonstration. (Section 5.7.4 and Figure 56). This ROI for nitrate degradation was estimated to be at least 56 ft (Section 5.7.4 and Figure 59). The performance objective for implementability was an ROI of 10 ft. Therefore, the performance objective was met.

These ROIs were based on injection of a total of 100 scfh of gas into P4 at 18 and 28 ft bgs. The ROI for oxygen depletion and electron donor transport was strongly affected by injection well design, gas flow rate, injection strategy (Sections 5.7.1 and 5.7.2). Use of six-inch long soil vapor probes as injection points and continuous injection of gas at relatively low flow rates was preferable to use of long well screens and pulsing of gas at relatively high flow rates. Gas composition also affected the ROI and the ROI varied with respect to depth. For example, LPG was transported a greater distance than hydrogen during Phase III injection of the $\text{H}_2/\text{CO}_2/\text{LPG}/\text{N}_2$ gas mixture (Figures 39 through 41). Hydrogen, because of its buoyancy, was limited in how deep it could be transported compared to LPG. The injection of this mixture was effective in reducing oxygen concentrations not only at the injection depths (i.e., 18 and 28 ft bgs), but also above and below these depths based on measured oxygen concentrations and observed perchlorate removals (Figure 67). Injection of pure LPG during Phase IV demonstrated that this gas could be transported significant distances but tended to sink resulting in elevated oxygen concentrations in shallow soil horizons (Figures 42 and 43). Thus, the ROI measured for this demonstration was operationally defined and should not be directly applied to other sites. Greater ROIs are possible and the most cost-effective and implementable approach will be determined by optimizing gas injection and well spacing.

7.0 COST ASSESSMENT

This section provides an assessment of full-scale GEDIT costs and drivers. The IRCTS-PBA site was used as a basis for developing the cost estimates. Four different scenarios were developed for in situ treatment of perchlorate in soil at this site. These scenarios were developed to compare actual demonstration design and operating conditions to likely full-scale design and operating conditions.

7.1 Cost Model

This section provides the technical basis of the cost estimates including descriptions of the scenarios, a list of assumptions, a discussion of significant design considerations, and a description of the project tasks for which costs were developed.

7.1.1 Technical Basis

This cost model is generally transferrable to other sites, however, it is important to note that the design basis (e.g., treatment goals, injection well design, gas injection strategy, etc.) will need to be tailored to site-specific conditions.

Four scenarios were considered and compared in this cost assessment for the IRCTS-PBA. Each scenario has different treatment objectives, gas compositions, and total soil volumes to be treated as listed in Table 17. Scenarios 1 and 3 have the treatment objective of reducing perchlorate concentrations to 60 µg/kg or less which is a potential cleanup goal for projection of groundwater as required by the California Regional Water Quality Control Board. Scenarios 2 and 4 have the treatment objective of achieving 90 percent mass reduction of perchlorate. Scenarios 1 and 2 are conservatively designed based on demonstration data and have an ROI of 10 ft and a gas composition based on 10 percent hydrogen. The 10 ft ROI is the minimum value based on demonstration data. The gas composition comprised of 10 percent hydrogen was used in the demonstration and lesser concentrations (i.e., 0.5 percent) were effective. Scenarios 3 and 4 have an ROI of 15 ft because limited demonstration data indicated this value was likely. Furthermore, the gas composition is one percent hydrogen and 99 percent nitrogen because hydrogen concentrations as low as 0.5 percent appear to be able to promote perchlorate degradation; LPG was not necessary for perchlorate reduction.

In summary, Scenario 1 represents the successful design used in the demonstration, and Scenario 2, 3, and 4 are alternative designs based on the demonstration data. Scenario 2 adopts the design from Scenario 1 but with a different treatment objective. Scenarios 3 and 4 have not been demonstrated per se, but have a reasonable chance of success based on demonstration data.

Table 17 – Design Basis for Each Scenario

	Scenario 1	Scenario 2	Scenario 3	Scenario 4
Treatment Objective	60 µg/kg perchlorate	90 percent mass reduction	60 µg/kg perchlorate	90 percent mass reduction
ROI (ft)	10	10	15	15
Nitrogen composition (percent)	79 percent	79 percent	99 percent	99 percent
Hydrogen composition (percent)	10 percent	10 percent	1 percent	1 percent
LPG composition (percent)	10 percent	10 percent	0 percent	0 percent
Total soil volume (cy)	550,000	310,000	550,000	310,000

7.1.2 Assumptions

The assumptions made during this cost assessment are summarized below:

- 1) Site characterization is complete and additional site investigation outside of treatability and pilot testing is not required.
- 2) The total areas of perchlorate contamination in different depth intervals (i.e., 0 to 20 ft bgs, 21 to 70 ft bgs, and 71 to 140 ft bgs) were estimated based on the data presented in the Remedial Investigation Report (Aerojet & HSI GeoTrans, 2000).
- 3) Surface soil (0 to 20 ft bgs) will be treated using excavation and costs are not included. GEDIT will only be used to treat the vadose zone from 21 ft to 140 ft bgs.
- 4) For Scenarios 2 and 4, 90 percent of the perchlorate mass in the 21 to 70 ft bgs interval was assumed to be contained in 70 percent of the total area associated with Scenarios 1 and 3. Similarly for the 71 to 140 ft bgs interval, 90 percent of the perchlorate mass was assumed to be contained in 50 percent of the total area.
- 5) Review of RI cross sections indicated significant heterogeneity with respect to perchlorate concentrations as a function of lateral and vertical distribution. Based on review of these data, only 20 percent of the area that was contaminated from 21 to 70 ft bgs was also contaminated from 71 to 140 ft bgs. Therefore, 20 percent of the wells were constructed with a gas injection interval from 21 to 140 ft bgs. The remaining wells were constructed with a gas injection interval either from 21 to 70 ft bgs or from 71 to 140 ft bgs. The gas injection interval was comprised of six-inch vapor probes located every 10 feet of depth and was based on the demonstration piezometer design.
- 6) The ratio of monitoring wells to injection wells is 1:10 and the monitoring wells are designed identically to the injection wells.
- 7) One full-time geologist will be on site during injection and monitoring well installation. A geologist will need to be on site only periodically to oversee well abandonment.
- 8) The treatment area would be treated 10 percent at a time. Therefore, treatment will be conducted in 10 stages, each of which will run for six months. The whole project will take five years.
- 9) Twenty soil borings will be needed in each scenario to demonstrate attainment of cleanup goals.
- 10) Unit costs such as those for electricity and supplied injection gases would not change over the course of the project.

- 11) A contingency of 15 percent was included on construction, operations, maintenance, and demobilization costs.

7.1.3 Design Considerations

Supply requirements for gases, water, and electricity will be site-specific. The rationale for each of these supplies is discussed in this section.

Nitrogen Generator

This cost estimate includes a nitrogen generator. Because of the high volume of nitrogen needed for injection, it is more economical to purchase a generator and produce nitrogen on-site than to buy nitrogen in tube trailers or liquid nitrogen tanks. If GEDIT is applied at a small site, it is possible that purchasing compressed or liquid nitrogen is more cost effective.

Hydrogen Generator

A hydrogen generator is included in the cost estimate for Scenarios 1 and 2 because of the large amount of hydrogen required. For Scenarios 3 and 4, hydrogen would be purchased from a gas vendor in tube trailers since that is more cost-effective. Because the volume of gas needed is site-specific, when estimating GEDIT implementation costs at another site, a cost comparison is needed to decide whether a hydrogen generator should be used.

Water Supply

Water is needed at the site to serve drilling activities (a secured water source located within ¼ miles of drilling operations reduces the drillers' effort). For Scenarios 1 and 2, water is also needed to supply the hydrogen generator. Two temporary water service options were considered: installation of a water line and water truck service. Cost comparison showed the former would be more economical at this site, so that was what included in the cost estimate. However, this decision should also be based on site-specific conditions when estimating GEDIT costs at other sites.

Electrical Supply

Electricity is required for operation of the gas generators and thus an electrical drop was required and the cost was estimated. Use of gas in compressed or liquefied forms at smaller sites would likely eliminate the need for an electrical drop.

7.1.4 Tasks Included in the Cost Model

The cost estimate for implementation of GEDIT at the IRCTS-PBA site includes seven tasks:

- Treatability Study
- Gas Permeability Test
- Injection System Design
- Installation
- Operation and Maintenance (O&M)
- Final Report and Demobilization
- Project Management

7.2 Cost Analysis

This section provides a cost comparison of each of the scenarios. The cost inputs for this estimate were based on demonstration data, vendor quotes, or professional guidance (e.g., Timberline) or judgment. The costs of nitrogen and hydrogen generators and required accessories are based on quotes from vendors. Construction costs were estimated with Timberline software. Drillers who previously worked at the site were contacted to quote drilling costs. Certified analytical laboratories located in California and Washington provided quotes for analytical costs. The cost breakdown for each scenario is presented in Table 18.

Scenario 1 represents the costs based on conservative demonstration design conditions and the unit cost is \$87/cy. Scenario 2 is based on the same gas composition and ROI as in Scenario 1, but the treatment area is reduced with a focus on mass reduction. The unit cost is reduced to \$68/cy under Scenario 2. Scenario 3 is comparable to Scenario 1 with respect to the treatment goal and area, but is based on a more reasonable design. These changes reduce the unit cost to \$21/cy. Scenario 4 is focused on mass reduction with a reasonable design and the unit cost is \$28/cy. The unit cost for Scenario 4 is greater than for Scenario 3 because the volume of soil is lower and many project costs are fixed.

When comparing each task across the different scenarios, the costs of the treatability study, gas permeability test, engineering design, and project management are similar under different scenarios. The cost of installation and demobilization under Scenario 1 is much greater than that under other scenarios because of higher labor cost for geologist labor, higher drilling cost and higher construction cost. The gas cost under O&M in Scenarios 1 and 2 is much greater than that of Scenarios 3 and 4 because of the high cost of LPG. The cost drivers are analyzed in more detail in Section 7.3.

Table 18 – Project Implementation Costs for GEDIT at IRCTS Site under Different Scenarios

Cost Element	Costs - Scenario 1		Costs - Scenario 2		Costs - Scenario 3		Costs - Scenario 4	
	Treatment to 60 µg/kg		90 percent Mass Reduction		Treatment to 60 µg/kg		90 percent Mass Reduction	
	10 percent H ₂ , 10 percent LPG, and N ₂ , 10-ft ROI		10 percent H ₂ , 10 percent LPG, and N ₂ , 10-ft ROI		1 percent H ₂ and N ₂ , 15-ft ROI		1 percent H ₂ and N ₂ , 15-ft ROI	
Task 1 & 2: Treatability Study and Gas Permeability Test	Task 1 & 2 Total = \$ 158,000		Task 1 & 2 Total = \$ 160,000		Task 1 & 2 Total = \$ 160,000		Task 1 & 2 Total = \$ 160,000	
· Personnel required and associated labor	Sr. Technical, 220 h	\$ 28,000	Sr. Technical, 220 h	\$ 28,000	Sr. Technical, 220 h	\$ 28,000	Sr. Technical, 220 h	\$ 28,000
· Drilling	Lab Scientist, 530 h	\$ 46,000	Lab Scientist, 530 h	\$ 46,000	Lab Scientist, 530 h	\$ 46,000	Lab Scientist, 530 h	\$ 46,000
· Analytical laboratory	Administrative, 11 h	\$ 1,000	Administrative, 11 h	\$ 1,000	Administrative, 11 h	\$ 1,000	Administrative, 11 h	\$ 1,000
· Sample Shipping	Drilling	\$ 47,000	Drilling	\$ 49,000	Drilling	\$ 49,000	Drilling	\$ 49,000
· Monthly laboratory usage fee	Analytical	\$ 16,000	Analytical	\$ 16,000	Analytical	\$ 16,000	Analytical	\$ 16,000
· Waste disposal	Miscellaneous costs	\$ 20,000	Miscellaneous costs	\$ 20,000	Miscellaneous costs	\$ 20,000	Miscellaneous costs	\$ 20,000
· Travel cost to the field								
Task 3: Engineering Design	Task 3 Total = \$ 67,000		Task 3 Total = \$ 67,000		Task 3 Total = \$ 55,000		Task 3 Total = \$ 55,000	
· Personnel required and associated labor	Sr. Technical, 280 h	\$ 36,000	Sr. Technical, 280 h	\$ 36,000	Sr. Technical, 220 h	\$ 28,000	Sr. Technical, 220 h	\$ 28,000
· Travel cost to the field	Project Engineer, 220 h	\$ 21,000	Project Engineer, 220 h	\$ 21,000	Project Engineer, 180 h	\$ 17,000	Project Engineer, 180 h	\$ 17,000
	Administrative, 96 h	\$ 9,000	Administrative, 96 h	\$ 9,000	Administrative, 96 h	\$ 9,000	Administrative, 96 h	\$ 9,000
	Miscellaneous costs	\$ 1,000	Miscellaneous costs	\$ 1,000	Miscellaneous costs	\$ 1,000	Miscellaneous costs	\$ 1,000
Task 4: Installation	Task 4 Total = \$ 17,612,000		Task 4 Total = \$ 9,566,000		Task 4 Total = \$ 7,422,000		Task 4 Total = \$ 4,703,000	
· Personnel required and associated labor	Sr. Technical, 22000 h	\$ 2,153,000	Sr. Technical, 12000 h	\$ 1,168,000	Sr. Technical, 9600 h	\$ 957,000	Sr. Technical, 5200 h	\$ 517,000
· Drilling	Project Engineer, 1100 h	\$ 102,000	Project Engineer, 580 h	\$ 55,000	Project Engineer, 480 h	\$ 45,000	Project Engineer, 260 h	\$ 24,000
· Materials (monitoring equip, H2/N2 Gen, Manifold and Piping)	Administrative, 40 h	\$ 4,000	Administrative, 40 h	\$ 4,000	Administrative, 24 h	\$ 2,000	Administrative, 24 h	\$ 2,000
· Installation (System, power, water)	Drilling	\$ 10,770,000	Drilling	\$ 5,744,000	Drilling	\$ 4,808,000	Drilling	\$ 2,619,000
	Construction	\$ 4,238,000	Construction	\$ 2,402,000	Construction	\$ 1,447,000	Construction	\$ 1,447,000
	Miscellaneous costs	\$ 345,000	Miscellaneous costs	\$ 193,000	Miscellaneous costs	\$ 163,000	Miscellaneous costs	\$ 94,000
Task 5: Operation and Maintenance	Task 5 Total = \$ 15,740,000		Task 5 Total = \$ 7,728,000		Task 5 Total = \$ 2,190,000		Task 5 Total = \$ 1,939,000	
· Personnel required and associated labor	Sr. Technical, 3600 h	\$ 369,000	Sr. Technical, 3600 h	\$ 368,000	Sr. Technical, 3600 h	\$ 369,000	Sr. Technical, 3600 h	\$ 368,000
· Drilling	Project Engineer, 56 h	\$ 5,000	Project Engineer, 56 h	\$ 5,000	Project Engineer, 56 h	\$ 5,000	Project Engineer, 56 h	\$ 5,000
· Analytical laboratory	Drilling	\$ 191,000	Drilling	\$ 180,000	Drilling	\$ 184,000	Drilling	\$ 180,000
· Sample shipping	Analytical	\$ 17,000	Analytical	\$ 16,000	Analytical	\$ 17,000	Analytical	\$ 16,000
· Gas	Gas	\$ 11,403,000	Gas	\$ 6,067,000	Gas	\$ 711,000	Gas	\$ 466,000
· Electricity	Electricity	\$ 3,566,000	Electricity	\$ 958,000	Electricity	\$ 845,000	Electricity	\$ 845,000
· System transfer, maintenance, and demobilization	Construction	\$ 184,000	Construction	\$ 129,000	Construction	\$ 54,000	Construction	\$ 54,000
· Travel cost to the field	Miscellaneous costs	\$ 5,000	Miscellaneous costs	\$ 5,000	Miscellaneous costs	\$ 5,000	Miscellaneous costs	\$ 5,000
Task 6: Final Report and Demobilization	Task 6 Total = \$ 8,088,000		Task 6 Total = \$ 575,000		Task 6 Total = \$ 491,000		Task 6 Total = \$ 286,000	
· Personnel required and associated labor	Sr. Technical, 210 h	\$ 28,000	Sr. Technical, 210 h	\$ 28,000	Sr. Technical, 210 h	\$ 28,000	Sr. Technical, 210 h	\$ 28,000
· Drilling	Project Engineer, 180 h	\$ 17,000	Project Engineer, 180 h	\$ 17,000	Project Engineer, 180 h	\$ 17,000	Project Engineer, 180 h	\$ 17,000
· Electrical demobilization	Administrative, 32 h	\$ 2,000	Administrative, 32 h	\$ 2,000	Administrative, 32 h	\$ 2,000	Administrative, 32 h	\$ 2,000
· Travel cost to the field	Drilling	\$ 8,034,000	Drilling	\$ 521,000	Drilling	\$ 437,000	Drilling	\$ 232,000
	Miscellaneous costs	\$ 7,000	Miscellaneous costs	\$ 7,000	Miscellaneous costs	\$ 7,000	Miscellaneous costs	\$ 7,000
Task 7: Project Management	Task 7 Total = \$ 114,000		Task 7 Total = \$ 85,000		Task 7 Total = \$ 78,000		Task 7 Total = \$ 66,000	
· Personnel required and associated labor	Project Manager, 710 h	\$ 99,000	Project Manager, 510 h	\$ 71,000	Project Manager, 470 h	\$ 66,000	Project Manager, 410 h	\$ 57,000
	Administrative, 240 h	\$ 14,000	Administrative, 220 h	\$ 13,000	Administrative, 180 h	\$ 11,000	Administrative, 140 h	\$ 8,000
	Miscellaneous costs	\$ 1,000	Miscellaneous costs	\$ 1,000	Miscellaneous costs	\$ 1,000	Miscellaneous costs	\$ 1,000
Contingency	\$ 6,221,000		\$ 2,687,000		\$ 1,519,000		\$ 1,045,000	
Total Cost	\$ 48,000,000		\$ 20,868,000		\$ 11,915,000		\$ 8,254,000	
Cost per Cubic Yard	\$ 87		\$ 68		\$ 21		\$ 27	

7.3 Cost Drivers

The total costs of implementing GEDIT are mainly driven by drilling-related costs and gas-related costs as presented in Table 19. The two major cost drivers together contributed 90 to 97 percent of the total costs. Both of these costs were significant but drilling was dominant in Scenarios 3 and 4. Each of the cost drivers is defined in the sections below.

Table 19 – Percentages of Total Costs Contributed by Major Cost Drivers

Cost Driver	Scenario 1	Scenario 2	Scenario 3	Scenario 4
Drilling	52 percent	44 percent	66 percent	55 percent
Gas	45 percent	48 percent	27 percent	35 percent
Sum	97 percent	93 percent	92 percent	90 percent

7.3.1 Sensitivity Analysis for Drilling Costs

The drilling-related costs include the drilling costs charged by the driller and geologists' labor. Both the drilling cost and the geologists' time are mainly dependent on the number of wells required and are therefore essentially dependent on the expected ROI of the injection wells. Taking Scenario 3 as an example, Figure 85 presents how the total costs change when the ROI is varied. By increasing the ROI from 10 ft to 15 ft, the total cost of Scenario 3 is reduced by half. As mentioned in Section 7.1.1, an ROI of 10 ft has been demonstrated at this site and an ROI of 15 ft is more likely. This sensitivity underscores the need for an accurate estimate of site ROI.

ROI is related to several factors including soil lithology and heterogeneity, gas flow rate and composition, well design, and superposition. Superposition is the synergistic effect of multiple injection wells working in concert to minimize effects of oxygen intrusion into the treatment zone. An injection well that is surrounded by other injection wells will be more efficient than a single well because lateral oxygen infiltration is minimized. The demonstration involved use of a single well location with injection at two depths. Installation of multiple wells in a grid pattern will result in greater ROI and/or lesser gas use as a result of superposition. Estimation of how much the ROI will be increased or the gas use will be decreased will require testing and/or modeling. Development of scenarios based on superposition was not conducted, but it is reasonable to conclude that additional cost reductions are possible.

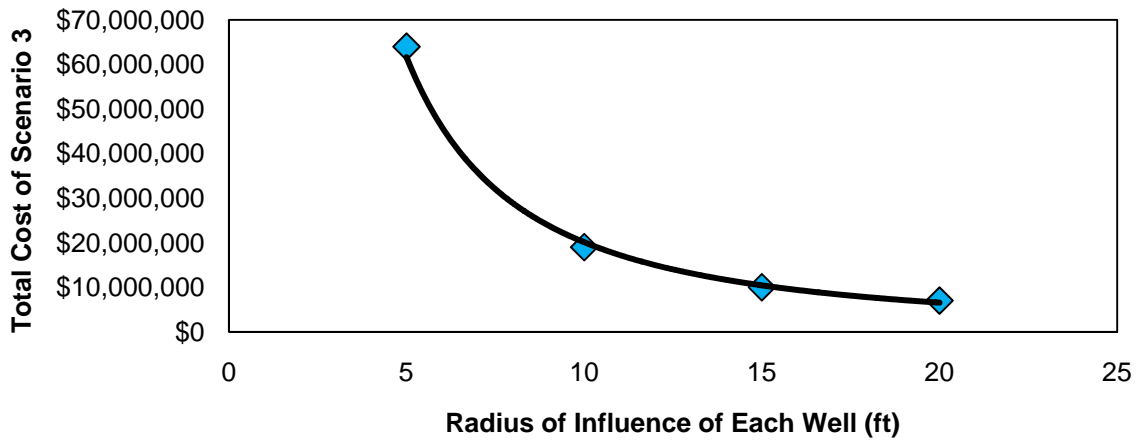

Figure 85 - Sensitivity Analyses for Drilling-Related Costs

7.3.2 Sensitivity Analysis for Gas Costs

Gas-related costs include gas generator equipment, purchase of compressed gas, and electricity including power drop and consumption. Gas-related costs are a larger percentage of the total cost in Scenarios 1 and 2 than in Scenarios 3 and 4 (Table 19) primarily because LPG was used in Scenarios 1 and 2 but not in Scenarios 3 and 4 (Table 17). Demonstration results indicated LPG did not play a critical role in promoting perchlorate degradation. Excluding LPG and just using hydrogen significantly reduces the total cost. LPG cost alone was nearly \$11 million for Scenario 1. The concentration of hydrogen also affects the total cost, but not as much. Figure 86 presents how the total cost of Scenario 3 would change as the hydrogen concentration increases. The total cost of Scenario 3 increases by 50 percent as the hydrogen concentration is increased from 1 to 10 percent.

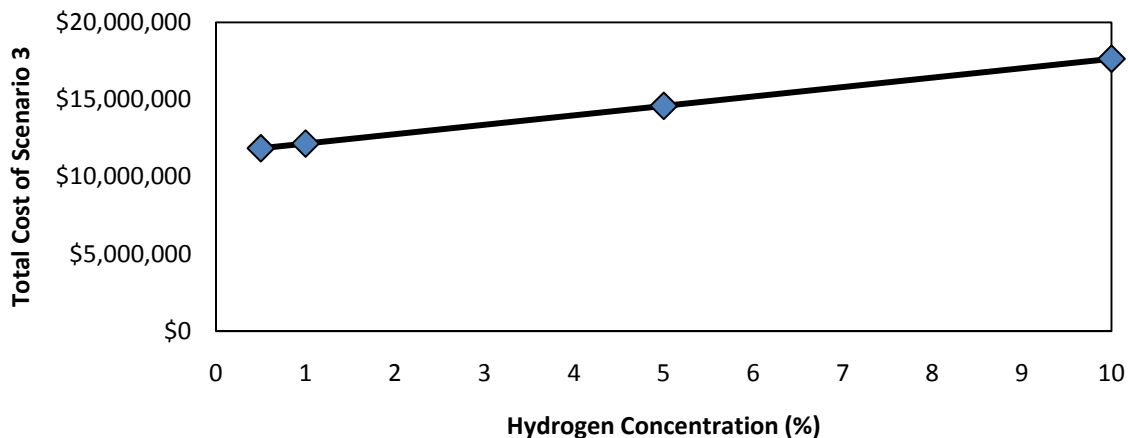

Figure 86 - Sensitivity Analyses for Gas-Related Costs

The majority of the gas expense is for nitrogen. The primary purpose of injecting nitrogen is to keep the vadose zone under anaerobic conditions since perchlorate can only be reduced anaerobically. Oxygen can infiltrate into treatment zone soil from above (e.g., barometric pumping from the atmosphere and/or diffusion), below (e.g., vadose zone soil deeper than the treatment zone or possibly dissolved oxygen in groundwater), and laterally (e.g., diffusion or advection along horizontal lithologic units). One possible way to reduce oxygen infiltration from above is to cover the treatment zone with plastic. Since the contact between the air and the soil has been reduced, it is reasonable to predict that less nitrogen is needed to keep the soil anaerobic. As discussed in Section 7.3.1, well superposition is likely to be most effective with respect to reduction of gas use. Centrally located wells (i.e., surrounded by adjacent wells) will require lower gas flow rates to prevent oxygen infiltration

7.4 Comparison to Alternative Approaches

An alternative approach to *in situ* treatment is excavation of vadose zone soil and *ex situ* bioremediation. This process includes soil excavation, rock screening and crushing, soil mixing with water and nutrients, storage in treatment cells during biodegradation, soil drying, and backfilling (Evans et al, 2008). Full-scale costs for this process were estimated to be about \$35/ton or \$45/cy. Given the depth of the vadose zone at the site (140 ft bgs), the unit cost would be even higher due to the significant benching and sloping that would be required. Compared with this *ex situ* approach, GEDIT is cost effective under Scenarios 3 and 4. Other alternatives for groundwater protection such as hydraulic containment via pump and treat may also be applicable. Additional evaluations would be necessary to assess whether GEDIT is cost effective in comparison. Nevertheless, well superposition and other refinements are likely to further increase the cost-effectiveness of GEDIT.

8.0 IMPLEMENTATION ISSUES

General engineering guidance for GEDIT implementation has been developed and is presented in Appendix F. This guidance includes guiding principles for design and operation of a GEDIT system. Additional implementation issues are described in this section.

8.1 Regulations and Permits

Federal or state regulations driving site cleanup will drive the need for GEDIT. The primary application for GEDIT is anticipated to be treatment of contaminants such as perchlorate in deep soil for the purpose of groundwater protection. The feasibility study process will include evaluation of GEDIT compared to other alternatives such as pump and treat, liquid flushing, and excavation.

Specific permits for GEDIT will be driven by local codes and will include drilling and well installation permits and hazardous materials storage permits. Other permits may be necessary and will be dependent on local codes.

8.2 End-User Concerns

Flammability is the primary end-user concern associated with GEDIT. As shown in this demonstration, this issue was easily managed and did not necessitate extraordinary efforts. The level of effort was similar to that for a construction site or remediation of a gasoline station site. Specifically the following observations and actions were part of this demonstration:

- Hydrogen was supplied in cylinders much in the same way that acetylene is supplied for welding at construction sites. The number of cylinders was greater than typically used at a construction site but these cylinders are contained in a commercially available rig that stabilizes and manifolds the cylinders.
- LPG was placed in a standard commercially available tank on a portable concrete pad. This effort is no different from a remediation site that uses a propane-fired thermal oxidizer or a construction site that uses LPG.
- Flammable gas/no smoking placards were used at the site. Such placards would be present at any gasoline station remediation site.
- Liquid nitrogen was supplied in a commercially available trailer. From a cold surface hazard perspective, liquid nitrogen is handled the same as liquid oxygen at hospitals and other commercial facilities.
- The Sacramento County Hazardous Materials Department and Aerojet-General Corporation were satisfied with the arrangements for the storage and use of flammable materials on the site. A standard hazardous materials permit was required by the County. Aerojet-General Corporation conducted a New Process Evaluation which is a standard requirement.
- Flammable gases were not detected above the ground surface. Thus, release of flammable gas to the atmosphere was not a safety issue. Nevertheless, monitoring of flammable gases should be conducted just as they would be during a gasoline station remediation project.

8.3 Procurement

Procurement of drilling services will be typical of any environmental remediation project. Procurement of compressed or liquefied gases can be accomplished through a variety of national vendors. Gas generators are specialized pieces of equipment but are available from several manufacturers. Gas manifolds and distribution systems are not off-the-shelf and will require engineering design and custom fabrication.

9.0 REFERENCES

- Aerojet Environmental Operations and HSI GeoTrans, Inc. (Aerojet & HSI GeoTrans) 2000. Remedial Investigation Report for the Vadose Zone at the Propellant Burn Area. Inactive Rancho Cordova Test site. Rancho Cordova, California. May.
- Aerojet General Corporation and Simon Hydro-Search, Inc. (AGC & Simon HSI), 1993. Revised Workplan for the Additional Characterization of the Propellant Burn Area, Circular Feature, and Municipal Landfill at the Inactive Rancho Cordova Test Site (IRCTS), October.
- California Department of Water Resources (DWR), 1964. Folsom-East Sacramento Groundwater Quality Investigation, Bulletin No. 133, March.
- CDM. 2007. Technology Demonstration Plan. In Situ Bioremediation of Perchlorate in Vadose Zone Soil Using Gaseous Electron Donors. ESTCP Project Number ER-0511.
- Coy, J.G., 1996. Summary of IRCST Sensitive Biota Field Investigation, 1993-1995, May.
- ENSR Consulting and Engineering, Inc., 1993. Preliminary Endangerment Assessment, Inactive Rancho Cordova Test Site, Rancho Cordova, California, January.
- Evans, P. J., and Trute, M. M., 2006. In Situ Bioremediation of Nitrate and Perchlorate in Vadose Zone Soil for Groundwater Protection Using Gaseous Electron Donor Injection Technology. *Water Environment Research* 78(13):2436-2446.
- Evans, P. J. 2007. Process for *In Situ* Bioremediation of Subsurface Contaminants. U. S. Patent No. 7,282,149. October 16.
- Fish and Wildlife Service (F&WS), 1994. U.S. Department of the Interior, National Wetlands Inventory, Buffalo Creek Quadrangle
- Fricke, R. A. and S. M. Carlton. 2005. Treatability Study of In-Situ Biodegradation of Perchlorate in the Unsaturated Zone. Presentation at NGWA Conference on MTBE and Perchlorate.
- Gibson and Skordal, 1999. Jurisdictional Delineation, June.
- Interstate Technology Regulatory Council (ITRC). 2005. Technology Overview. Perchlorate: Overview of Issues, Status, and Remedial Options. Washington D.C. September.
- Leeson, A. and R. Hinchee. 1996. Principles and Practices of Bioventing. Volume I: Bioventing Principles. Prepared for the U.S. Air Force. September 29. pp. 39-40.
- McCormick, N. G., F. E. Feeherry, and H. S. Levinson. 1976. Microbial Transformation of 2,4,6-Trinitrotoluene and other Nitroaromatic Compounds. *Appl. Environ. Microbiol.* **31**:949-958.

- Motzer, W. E. 2001. "Perchlorate: Problems, Detection, and Solutions." *Environmental Forensics*. **2**:300-311.
- Perry, R. H., and C. H. Chilton. 1973. *Chemical Engineers' Handbook*. Fifth Edition. McGraw-Hill, New York.
- Rainwater, K., J. Brown, C. Heintz, T. Mollhagen, and L.D. Hansen. 2001. "Design, Construction, and Operation of a Field Demonstration for In Situ Biodegradation of Vadose Zone Soils Contaminated with High Explosives," ERDC/EL TR-01-28, U.S. Army Engineer Research and Development Center, Vicksburg, MS.
- Soil Conservation Service (SCS), 1993. U.S. Department of Agriculture, Soil Survey of Sacramento County, California, April.
- U. S. EPA. 2004. http://www.epa.gov/fedfac/pdf/Releases_04_29_04-with-datesDB.pdf
- U. S. EPA. 2005. Perchlorate (ClO_4^-) and Perchlorate Salts. Integrated Risk Information System (IRIS); U.S. Environmental Protection Agency: Washington, D.C., <http://www.epa.gov/iris/subst/1007.htm>. February 18.
- U. S. EPA. 2006a. Assessment Guidance for Perchlorate, memorandum from Susan Parker Bodine to Regional Administrators; U.S. Environmental Protection Agency, Office of Solid Waste and Emergency Response: Washington, D.C.
- U. S. EPA. 2006b. In Situ Treatment Technologies for Contaminated Soil. Engineering Forum Issue Paper. EPA 542/F-06/013. Office of Solid Waste and Emergency Response. Washington, D.C.
- U.S. EPA. 2008. Interim Drinking Water Health Advisory for Perchlorate. EPA 822-R-08-225. December.
- U. S. Geological Survey (USGS), 1980. Buffalo Creek Quadrangle, California, Sacramento County, 7.5 Minute Series.
- Wagner, D. L., et al., 1981. Geologic Map of the Sacramento Quadrangle, California Division of Mines and Geology, 1:250,000.
- Xu, J., S. Yanguang, B. Min, L. Steinberg, and B.E. Logan. 2003. "Microbial degradation of perchlorate: principles and applications." *Environmental Engineering Science*, **20** (5): 405 – 422.

APPENDICES

Appendix A: Points of Contact

POINT OF CONTACT Name	ORGANIZATION Name Address	Phone Fax E-mail	Role in Project
Patrick Evans	CDM, 14432 S.E. Eastgate Way, Suite 100, Bellevue, WA 98007	425 519 8300 425 746 0197 evanspj@cdm.com	Principal Investigator
Rachel Brennan	The Pennsylvania State University, Department of Civil and Environmental Engineering, University Park, PA 16802	814 865 9428 rbrennan@enr.psu.edu	Co- Principal Investigator
Rodney Fricke	Aerojet-General Corp., P.O. Box 13222, MS-5519, Sacramento, CA 95813	916 355 5161 916 355 6145 rodney.fricke@aerojet.com	Site Owner
Alexander MacDonald	California Regional Water Quality Control Board, Central Valley Region, 11020 Sun Center Drive, Suite 200, Rancho Cordova, CA 95670	916 464 4625 amacdonald@waterboards.ca.gov	Site Regulator
Andrea Leeson	ESTCP Program Office, 901 Stuart Street, Suite 303, Arlington, VA 22203	703 696 2118 andrea.leeson@osd.mil	ESTCP Program Manager
Bryan Harre	NAVFAC ESC, 1100 23 rd Avenue, Port Hueneme, CA 93043	805 982 1795 bryan.harre@navy.mil	COTR

Appendix B: Boring Logs and Well/Piezometer Construction Details



2295 Gateway Oaks
Suite 240
Sacramento, CA 95833
(916) 567-9900

BORING/WELL CONSTRUCTION LOG

PROJECT NUMBER 4000-46738 BORING/WELL NUMBER CDM-INJ1
 PROJECT NAME Aerojet - GEDIT DATE DRILLED 07/31/06
 LOCATION Rancho Cordova, CA CASING TYPE/DIAMETER Sch 40 PVC/6-inch
 DRILLING METHOD Sonic SCREEN TYPE/SLOT 6-inch Sch 40 PVC/20 Slot
 SAMPLING METHOD Continuous Core GRAVEL PACK TYPE No. 3 Monterey Beach Sand
 GROUND SURFACE ELEVATION (FT MSL) NA GROUT TYPE/QUANTITY Bentonite Grout
 TOP OF CASING ELEVATION (FT MSL) NA STATIC WATER LEVEL (FT BELOW TOC) NA
 LOGGED BY T.Titus GROUND WATER ELEVATION (FT MSL) _____
 REMARKS _____

PID (ppm)	BLOW COUNTS	RECOVERY (inches)	SAMPLE ID.	EXTENT	DEPTH (ft. bgs)	U.S.C.S.	GRAPHIC LOG	LITHOLOGIC DESCRIPTION	CONTACT DEPTH	WELL DIAGRAM
0.0					5	ML		SILT: brown (10YR 4/3); 100% silt, firm, low plasticity; dry, no odor.		
0.0					10	CL		CLAY: dark yellowish brown (10YR 3/4); 100% clay, soft, high plasticity; moist, no odor.	10.0	
0.0					15	ML		SILT: brown (10YR 4/3); 100% silt, firm, low plasticity; moist, no odor.	13.0	
0.0					20	CL		CLAY: dark yellowish brown (10YR 3/4); 100% clay, soft, high plasticity; moist, no odor.	18.0	
0.0					25	GC		CLAYEY GRAVEL: brown (7.5YR 4/3); 60% gravel, well graded, fine and coarse grained, maximum diameter of 3 inches, angular to rounded; 30% clay, soft, medium plasticity; 10% cobbles, maximum diameter of 5 inches, subrounded to rounded; moist, no odor.	20.0	
0.0					30			SILTY SAND WITH GRAVEL: brown (7.5YR 4/3); 40% sand, well graded, fine to coarse grained, angular to rounded; 30% silt, soft, non-plastic; 30% gravel, well graded, fine and coarse grained, maximum diameter of 3 inches, angular to rounded; trace cobbles, maximum diameter of 6 inches, rounded; moist, no odor.	25.0	
0.0					35			Cobbles from 35 to 38 feet below ground surface.		
0.0					40					

NEWGINT_SAC_AEROJET_120908.GPJ NEWGINT.GDT 11/13/09

Continued Next Page



2295 Gateway Oaks
Suite 240
Sacramento, CA 95833
(916) 567-9900

BORING/WELL CONSTRUCTION LOG

PROJECT NUMBER 4000-46738 BORING/WELL NUMBER CDM-INJ1
PROJECT NAME Aerojet - GEDIT DATE DRILLED 07/31/06

Continued from Previous Page

PID (ppm)	BLOW COUNTS	RECOVERY (inches)	SAMPLE ID.	EXTENT	DEPTH (ft. bgs)	U.S.C.S.	GRAPHIC LOG	LITHOLOGIC DESCRIPTION	CONTACT DEPTH	WELL DIAGRAM
0.0					45	SM		SILTY SAND WITH GRAVEL: brown (7.5YR 4/2); 60% sand, well graded, fine to coarse grained, angular to subrounded; 20% silt, soft, non-plastic; 20% gravel, well graded, fine and coarse grained, maximum diameter of 3 inches, subangular to rounded; trace cobbles, maximum diameter of 5 inches, rounded; moist, no odor.		
0.0					50					Screen (10-70 ft bgs)
0.0					55					Sand (8-70.5 ft bgs)
0.0					60			SILTY SAND WITH GRAVEL: brown (7.5YR 4/2); 60% sand, well graded, fine to coarse grained, angular to subrounded; 20% silt, soft, non-plastic; 20% gravel, well graded, fine and coarse grained, maximum diameter of 3 inches, subangular to angular; moist, no odor.		
0.0					65					
0.0					70				70.5	
								Total depth of borehole was 70.5 feet below ground surface.		
					75					
					80					
					85					

NEWGINT_SAC_AEROJET_120908.GPJ NEWGINT.GDT 11/13/09



2295 Gateway Oaks
Suite 240
Sacramento, CA 95833
(916) 567-9900

BORING/WELL CONSTRUCTION LOG

PROJECT NUMBER 56111-6169.001.TK5.MOBIL BORING/WELL NUMBER CDM-INJ2
 PROJECT NAME Aerojet - GEDIT DATE DRILLED 10/26/07
 LOCATION Rancho Cordova, CA CASING TYPE/DIAMETER Sch 40 PVC/4-inch
 DRILLING METHOD Sonic SCREEN TYPE/SLOT 4-inch Sch 40 PVC/20 Slot
 SAMPLING METHOD Continuous Core GRAVEL PACK TYPE No. 3 Monterey Beach Sand
 GROUND SURFACE ELEVATION (FT MSL) NA GROUT TYPE/QUANTITY Portland Type I/II Cement
 TOP OF CASING ELEVATION (FT MSL) NA STATIC WATER LEVEL (FT BELOW TOC) NA
 LOGGED BY T.Titus GROUND WATER ELEVATION (FT MSL) _____
 REMARKS _____

PID (ppm)	BLOW COUNTS	RECOVERY (inches)	SAMPLE ID.	EXTENT	DEPTH (ft. bgs)	U.S.C.S.	GRAPHIC LOG	LITHOLOGIC DESCRIPTION	CONTACT DEPTH	WELL DIAGRAM
0.0	100				5	ML		SILT: brown (10YR 4/3); 100% silt, soft, low plasticity; dry, no odor.	6.0	<p>Cement Grout (0-5 ft bgs) Casing (0-10 ft bgs) Bentonite (5-8 ft bgs) Screen (10-50 ft bgs) Sand (8-50 ft bgs)</p>
0.0	100				10	CL		CLAY: dark yellowish brown (10YR 3/4); 100% clay, soft, low plasticity; moist, no odor.	6.0	
0.0	100				15	ML		SILT: brown (10YR 4/3); 100% silt, soft, low plasticity; dry, no odor.	10.0	
0.0	100				15	CL		CLAY: dark yellowish brown (10YR 3/4); 100% clay, soft, moderate plasticity; moist, no odor.	15.0	
0.0	100				17.0	CL		CLAY: dark yellowish brown (10YR 3/4); 100% clay, firm, moderate plasticity; moist, no odor.	17.0	
0.0	100				20	CL		CLAY: dark yellowish brown (10YR 3/4); 100% clay, firm, moderate plasticity; moist, no odor.	20.0	
0.0	100				23.0	CL		CLAY: dark yellowish brown (10YR 3/4); 100% clay, soft, moderate plasticity; moist, no odor.	23.0	
0.0	100				25.0	CL		CLAY: dark yellowish brown (10YR 3/4); 100% clay, firm, moderate plasticity; moist, no odor.	25.0	
0.0	100				29.0	SM		SILTY SAND WITH GRAVEL: brown (7.5YR 4/3); 40% sand, well graded, fine to coarse grained, angular to rounded; 30% silt, non-plastic; 30% gravel, well graded, fine and coarse grained, maximum diameter of 2 inches, angular to rounded; moist, no odor.	29.0	
0.0	100				31.0			CLAYEY GRAVEL WITH SAND: dark yellowish brown (10YR 4/4); 45% gravel, well graded, fine and coarse grained, maximum diameter of 3 inches, subangular to rounded; 30% clay, soft, low plasticity; 20% sand, well	31.0	

NEWGINT_SAC_AEROJET_120908.GPJ_NEWGINT.GDT 11/13/09

Continued Next Page



2295 Gateway Oaks
Suite 240
Sacramento, CA 95833
(916) 567-9900

BORING/WELL CONSTRUCTION LOG

PROJECT NUMBER 56111-6169.001.TK5.MOBIL BORING/WELL NUMBER CDM-INJ2
PROJECT NAME Aerojet - GEDIT DATE DRILLED 10/26/07

Continued from Previous Page

PID (ppm)	BLOW COUNTS	RECOVERY (inches)	SAMPLE ID.	EXTENT	DEPTH (ft. bgs)	U.S.C.S.	GRAPHIC LOG	LITHOLOGIC DESCRIPTION	CONTACT DEPTH	WELL DIAGRAM
0.0		100				GC		graded, fine to coarse grained, angular to rounded; 5% cobbles, maximum diameter of 6 inches, rounded to subangular; moist, no odor.		<p>Screen (10-50 ft bgs)</p> <p>Sand (8-50 ft bgs)</p>
0.0		100			40					
0.0		100			45	SP-SM		SAND WITH SILT AND GRAVEL: brown (10YR 4/3); 50% sand, poorly graded, fine to coarse grained, mostly fine grained, subangular to subrounded; 35% gravel, well graded, fine and coarse grained, maximum diameter of 3 inches, subangular to rounded; 10% silt, soft, non-plastic, 5% cobbles, maximum diameter of 4 inches, subangular to rounded; moist, no odor.	45.0	
0.0		100			50			Total depth of borehole was 50 feet below ground surface.	50.0	
					55					
					60					
					65					
					70					
					75					

NEWGINT_SAC_AEROJET_120908.GPJ_NEWGINT.GDT 11/13/09



2295 Gateway Oaks
Suite 240
Sacramento, CA 95833
(916) 567-9900

BORING/WELL CONSTRUCTION LOG

PROJECT NUMBER 56111-6169.001.TK5.MOBIL BORING/WELL NUMBER CDM-INJ3
 PROJECT NAME Aerojet - GEDIT DATE DRILLED 10/17/08
 LOCATION Rancho Cordova, CA CASING TYPE/DIAMETER Sch 40 PVC/4-inch
 DRILLING METHOD Sonic SCREEN TYPE/SLOT 4-inch Sch 40 PVC/20 Slot
 SAMPLING METHOD Continuous Core GRAVEL PACK TYPE No. 3 Monterey Beach Sand
 GROUND SURFACE ELEVATION (FT MSL) NA GROUT TYPE/QUANTITY Portland Type I/II Cement
 TOP OF CASING ELEVATION (FT MSL) NA STATIC WATER LEVEL (FT BELOW TOC) NA
 LOGGED BY T.Titus GROUND WATER ELEVATION (FT MSL) _____
 REMARKS _____

PID (ppm)	BLOW COUNTS	RECOVERY (inches)	SAMPLE ID.	EXTENT	DEPTH (ft. bgs)	U.S.C.S.	GRAPHIC LOG	LITHOLOGIC DESCRIPTION	CONTACT DEPTH	WELL DIAGRAM
0.0	100				5	ML		SILT: brown (10YR 4/3); 100% silt, firm, low plasticity; dry, no odor.	6.0	<p>Cement Grout (0-5 ft bgs) Casing (0-10 ft bgs) Bentonite (5-8 ft bgs) Screen (10-50 ft bgs) Sand (8-50 ft bgs)</p>
0.0	100				8.0	CL		CLAY: dark yellowish brown (10YR 3/4); 100% clay, soft, high plasticity; moist, no odor.	8.0	
0.0	100				10	GC		CLAYEY GRAVEL: brown (7.5YR 4/3); 60% gravel, well graded, fine and coarse grained, maximum diameter of 3 inches, angular to rounded; 30% clay, soft, moderate plasticity; 10% cobbles, maximum diameter of 6 inches, subrounded to rounded; moist, no odor.		
0.0	100			15						
0.0	100				20	GC				
0.0	100			23.0						
0.0	100				25	SM		SILTY SAND WITH GRAVEL: brown (7.5YR 4/3); 40% sand, well graded, fine to coarse grained, angular to rounded; 30% silt, soft, non-plastic; 30% gravel, well graded, fine and coarse grained, maximum diameter of 3 inches, angular to rounded; trace cobbles, maximum diameter of 6 inches, rounded; moist, no odor.	23.0	
0.0	100				32.0	SP		SAND: pale brown (10YR 6/3); 100% sand, poorly graded, fine grained; dry, no odor.	32.0	
0.0	100				34.0	GC		CLAYEY GRAVEL WITH SAND: dark yellowish brown	34.0	
					35.0				35.0	

NEWGINT_SAC_AEROJET_120908.GPJ_NEWGINT.GDT 11/13/09

Continued Next Page



2295 Gateway Oaks
Suite 240
Sacramento, CA 95833
(916) 567-9900

BORING/WELL CONSTRUCTION LOG

PROJECT NUMBER 56111-6169.001.TK5.MOBIL

BORING/WELL NUMBER CDM-INJ3

PROJECT NAME Aerojet - GEDIT

DATE DRILLED 10/17/08

Continued from Previous Page

PID (ppm)	BLOW COUNTS	RECOVERY (inches)	SAMPLE ID.	EXTENT	DEPTH (ft. bgs)	U.S.C.S.	GRAPHIC LOG	LITHOLOGIC DESCRIPTION	CONTACT DEPTH	WELL DIAGRAM
0.0		100				ML		(10YR 4/4); 50% gravel, well graded, fine and coarse grained, maximum diameter of 3 inches, subangular to rounded; 30% clay, soft, low plasticity; 20% sand, poorly graded, medium to coarse grained, mostly coarse, angular to subrounded; trace cobbles, maximum diameter of 6 inches, subrounded to rounded; moist, no odor.		<p>Screen (10-50 ft bgs)</p> <p>Sand (8-50 ft bgs)</p>
0.0		70			40	SP		SANDY SILT WITH GRAVEL: brown (10YR 4/3); 50% silt, soft, non-plastic; 30% sand, poorly graded, fine to coarse grained, mostly fine grained, angular to subangular; 20% gravel, well graded, fine and coarse grained, maximum diameter of 3 inches, subrounded to subangular; trace cobbles, subrounded to subangular, maximum diameter of 6 inches; moist, no odor.	40.0	
0.0		70			45	SW		SAND WITH GRAVEL: brown (10YR 4/3); 60% sand, poorly graded, fine to coarse grained, mostly coarse, subrounded to angular; 40% gravel, well graded, fine and coarse grained, maximum diameter of 3 inches, subrounded to angular; moist, no odor.	45.0	
0.0		100			50			SAND WITH GRAVEL: dark yellowish brown (10YR 4/4); 60% sand, well graded, fine to coarse grained, angular to subrounded; 40% gravel, well graded, fine and coarse grained, maximum diameter of 3 inches, subrounded to subangular; trace cobbles, maximum diameter of 5 inches, subrounded to subangular; moist, no odor.	50.0	
								Total depth of borehole was 50 feet below ground surface.		
					55					
					60					
					65					
					70					
					75					



2295 Gateway Oaks
Suite 240
Sacramento, CA 95833
(916) 567-9900

BORING/WELL CONSTRUCTION LOG

PROJECT NUMBER 4000-46738 BORING/WELL NUMBER CDM-P1
 PROJECT NAME Aerojet - GEDIT DATE DRILLED 07/27/06
 LOCATION Rancho Cordova, CA CASING TYPE/DIAMETER Poly Tubing/0.25-inch ID
 DRILLING METHOD Sonic SCREEN TYPE/SLOT 0.25-inch Stainless Steel Vapor Probe
 SAMPLING METHOD Continuous Core GRAVEL PACK TYPE No. 3 Monterey Beach Sand
 GROUND SURFACE ELEVATION (FT MSL) NA GROUT TYPE/QUANTITY Bentonite Grout
 TOP OF CASING ELEVATION (FT MSL) NA STATIC WATER LEVEL (FT BELOW TOC) NA
 LOGGED BY T.Titus GROUND WATER ELEVATION (FT MSL) _____
 REMARKS _____

PID (ppm)	BLOW COUNTS	RECOVERY (inches)	SAMPLE ID.	EXTENT	DEPTH (ft. bgs)	U.S.C.S.	GRAPHIC LOG	LITHOLOGIC DESCRIPTION	CONTACT DEPTH	WELL DIAGRAM
0.0					5	ML		SILT: yellowish brown (10YR 5/4); 100% silt, soft, non-plastic; dry; no odor.	6.0	<ul style="list-style-type: none"> Cement Grout (0-16 ft bgs) Poly Tubing (0-18, 0-33, 0-48, and 0-68 ft bgs) Bentonite (16-17 ft bgs) Sand (17-19.5 ft bgs) Vapor Probe (18-18.5 ft bgs) Bentonite (19.5-32 ft bgs) Sand (32-34.5 ft bgs) Vapor Probe (33-33.5 ft bgs) Bentonite (34.5-47 ft bgs)
0.0					10	ML		GRAVELLY SILT: yellowish brown (10YR 5/4); 60% silt, soft, non-plastic; 40% gravel, well graded, fine and coarse grained, maximum diameter of 3 inches, subround to rounded; dry, no odor.	13.0	
0.0					15	ML		GRAVELLY SILT WITH SAND: brown (7.5YR 4/3); 50% silt, soft, non-plastic; 35% gravel, well graded, fine and coarse grained, maximum diameter of 3 inches, subangular to rounded; 15% sand, poorly graded, medium to coarse grained, subrounded; moist, no odor.	23.0	
0.0					25	GC		CLAYEY GRAVEL WITH SAND: dark yellowish brown (10YR 4/4); 45% gravel, well graded, fine and coarse grained, maximum diameter of 3 inches, subangular to rounded; 35% clay, soft, low plasticity; 20% sand, poorly graded, coarse grained, subrounded to rounded; moist, no odor.	34.0	
0.0					35	SP		SAND: pale brown (10YR 6/3); 100% sand, poorly graded, fine grained; dry, no odor.	35.0	
0.0					40			CLAYEY GRAVEL WITH SAND: dark yellowish brown (10YR 4/4); 45% gravel, well graded, fine and coarse grained, maximum diameter of 3 inches, subangular to rounded; 35% clay, soft, low plasticity; 20% sand, poorly graded, coarse grained, subrounded to rounded; moist, no odor.		

NEWGINT_SAC_AEROJET_120908.GPJ NEWGINT.GDT 11/13/09

Continued Next Page



2295 Gateway Oaks
Suite 240
Sacramento, CA 95833
(916) 567-9900

BORING/WELL CONSTRUCTION LOG

PROJECT NUMBER 4000-46738

BORING/WELL NUMBER CDM-P1

PROJECT NAME Aerojet - GEDIT

DATE DRILLED 07/27/06

Continued from Previous Page

PID (ppm)	BLOW COUNTS	RECOVERY (inches)	SAMPLE ID.	EXTENT	DEPTH (ft. bgs)	U.S.C.S.	GRAPHIC LOG	LITHOLOGIC DESCRIPTION	CONTACT DEPTH	WELL DIAGRAM
0.0						GC				
0.0					45	SM		SILTY SAND: dark yellowish brown (10YR 4/4); 70% sand, poorly graded, fine to medium grained, subrounded to subangular; 30% silt, firm, non-plastic; moist, no odor.	45.0	<ul style="list-style-type: none"> Poly Tubing (0-18, 0-33, 0-48, and 0-68 ft bgs) Sand (47-49.6 ft bgs) Vapor Probe (48-48.5 ft bgs)
					50	SM				
					52.0	SM		SILTY SAND WITH GRAVEL: dark yellowish brown (10YR 4/4); 40% sand, well graded, fine to coarse grained, subangular to subrounded; 30% silt, firm, non-plastic; 30% gravel, well graded, fine and coarse grained, maximum diameter of 3 inches, angular to rounded; moist, no odor.	52.0	
					55	SM				
					60	SM				Bentonite (49.6-67 ft bgs)
					62.0	SC		CLAYEY SAND WITH GRAVEL: dark yellowish brown (10YR 4/4); 40% sand, well graded, fine to coarse grained, subangular to subrounded; 30% clay, firm, low plasticity; 30% gravel, well graded, fine and coarse grained, maximum diameter of 3 inches, angular to rounded; moist, no odor.	62.0	
					65	SM				
					65.0	SM		SILTY SAND WITH GRAVEL: dark yellowish brown (10YR 4/4); 40% sand, well graded, fine to coarse grained, subangular to subrounded; 30% silt, firm, non-plastic; 30% gravel, well graded, fine and coarse grained, maximum diameter of 3 inches, angular to rounded; moist, no odor.	65.0	<ul style="list-style-type: none"> Sand (67-69 ft bgs) Vapor Probe (68-68.5 ft bgs)
					70	SM				
					72.0			Total depth of borehole was 72 feet below ground surface.	72.0	Bentonite (69-72 ft bgs)
					75					
					80					
					85					

NEWGINT_SAC_AEROJET_120908.GPJ_NEWGINT.GDT 11/13/09



2295 Gateway Oaks
Suite 240
Sacramento, CA 95833
(916) 567-9900

BORING/WELL CONSTRUCTION LOG

PROJECT NUMBER 56111-6169.001.TK5.MOBIL BORING/WELL NUMBER CDM-P2
 PROJECT NAME Aerojet - GEDIT DATE DRILLED 10/25/07
 LOCATION Rancho Cordova, CA CASING TYPE/DIAMETER Poly Tubing/0.25-inch ID
 DRILLING METHOD Sonic SCREEN TYPE/SLOT 0.25-inch Stainless Steel Vapor Probe
 SAMPLING METHOD Continuous Core GRAVEL PACK TYPE No. 3 Monterey Beach Sand
 GROUND SURFACE ELEVATION (FT MSL) NA GROUT TYPE/QUANTITY Portland Type I/II Cement
 TOP OF CASING ELEVATION (FT MSL) NA STATIC WATER LEVEL (FT BELOW TOC) NA
 LOGGED BY K. Hopfensperger GROUND WATER ELEVATION (FT MSL) _____
 REMARKS _____

PID (ppm)	BLOW COUNTS	RECOVERY (inches)	SAMPLE ID.	EXTENT	DEPTH (ft. bgs)	U.S.C.S.	GRAPHIC LOG	LITHOLOGIC DESCRIPTION	CONTACT DEPTH	WELL DIAGRAM
0.3		100			5	CL		CLAY: moderate brown (5YR 4/4); 100% sandy clay, moderate to high plasticity, trace very fine grained quartz; dry, no odor.		
0.0		100			10	CL		GRAVELLY CLAY: moderate brown (5YR 4/4); 60% sandy clay, moderate to high plasticity, trace very fine grained quartz; 40% gravel, subrounded to subangular, maximum diameter 3 inches; dry, no odor.	10.0	
0.0		100			15	GW		GRAVEL WITH SAND: moderate brown (5YR 4/4); 60% gravel, subrounded, maximum diameter of 3 inches; 40% silty sand, fine grained, moderately poorly graded, subrounded; dry, no odor.	15.0	
0.2		100			20	GW		GRAVEL WITH SAND: moderate brown (5YR 4/4); 75% gravel, maximum diameter 2 inches, rounded to subrounded; 25% clayey sand to sand, fine grained; dry, no odor.	20.0	
0.0		75			25	GW		GRAVEL WITH SAND: moderate brown (5YR 4/4); 50% gravel, maximum diameter 2 inches, rounded to subrounded; 50% clayey sand to sand, fine grained; dry, no odor.	25.0	
0.5		75			30	GW		GRAVEL WITH SAND: moderate brown (5YR 4/4); 60% gravel, maximum diameter 2 inches, rounded to subrounded; 40% silty sand, fine grained, rounded to subrounded; dry, no odor.	30.0	
					35				35.0	

Continued Next Page



2295 Gateway Oaks
Suite 240
Sacramento, CA 95833
(916) 567-9900

BORING/WELL CONSTRUCTION LOG

PROJECT NUMBER 56111-6169.001.TK5.MOBIL BORING/WELL NUMBER CDM-P2
PROJECT NAME Aerojet - GEDIT DATE DRILLED 10/25/07

Continued from Previous Page

PID (ppm)	BLOW COUNTS	RECOVERY (inches)	SAMPLE ID.	EXTENT	DEPTH (ft. bgs)	U.S.C.S.	GRAPHIC LOG	LITHOLOGIC DESCRIPTION	CONTACT DEPTH	WELL DIAGRAM
0.2		100				SP		SAND WITH GRAVEL: moderate brown (5YR 4/4); 70% clayey sand, fine grained, rounded to subrounded, low plasticity; 30% gravel, subrounded to subangular, maximum diameter 1.5 inches.		
0.0		100			40			GRAVELLY CLAY: moderate brown (5YR 4/4); 50% sandy clay, low plasticity; 50% gravel and cobbles, maximum diameter 4 inches, subangular to angular; dry, no odor.	40.0	
0.0		100			45	CL				
0.0		100			50			Drill cuttings not collected between 50 and 52 feet below ground surface. Lithology assumed to be same as 40 to 50 feet below ground surface.	52.0	
								Total depth of borehole was 52 feet below ground surface.		
					55					
					60					
					65					
					70					
					75					

NEWGINT_SAC_AEROJET_120908.GPJ_NEWGINT.GDT 11/13/09



2295 Gateway Oaks
Suite 240
Sacramento, CA 95833
(916) 567-9900

BORING/WELL CONSTRUCTION LOG

PROJECT NUMBER 56111-6169.001.TK5.MOBIL BORING/WELL NUMBER CDM-P3
 PROJECT NAME Aerojet - GEDIT DATE DRILLED 10/23/07
 LOCATION Rancho Cordova, CA CASING TYPE/DIAMETER Poly Tubing/0.25-inch ID
 DRILLING METHOD Sonic SCREEN TYPE/SLOT 0.25-inch Stainless Steel Vapor Probe
 SAMPLING METHOD Continuous Core GRAVEL PACK TYPE No. 3 Monterey Beach Sand
 GROUND SURFACE ELEVATION (FT MSL) NA GROUT TYPE/QUANTITY Portland Type I/II Cement
 TOP OF CASING ELEVATION (FT MSL) NA STATIC WATER LEVEL (FT BELOW TOC) NA
 LOGGED BY K. Hopfensperger GROUND WATER ELEVATION (FT MSL) _____
 REMARKS _____

PID (ppm)	BLOW COUNTS	RECOVERY (inches)	SAMPLE ID.	EXTENT	DEPTH (ft. bgs)	U.S.C.S.	GRAPHIC LOG	LITHOLOGIC DESCRIPTION	CONTACT DEPTH	WELL DIAGRAM
						ML		SILT: light brown (5YR 5/6); low plasticity; dry, no odor.	5.0	<p>Cement Grout (0-14 ft bgs)</p> <p>Poly Tubing (0-18, 0-28, 0-38, and 0-48 ft bgs)</p> <p>Bentonite (14-17 ft bgs)</p> <p>Sand (17-19.5 ft bgs)</p> <p>Vapor Probe (18-18.5 ft bgs)</p> <p>Bentonite (19.5-27 ft bgs)</p> <p>Sand (27-29.5 ft bgs)</p> <p>Vapor Probe (28-28.5 ft bgs)</p> <p>Bentonite (29.5-37 ft bgs)</p>
0.1	50				5	CL		CLAY: moderate brown (5YR 4/4); 100% clay, moderate to high plasticity; dry, no odor.	10.0	
0.1	100				10	SP		SAND: light brown (5YR 5/6); fine grained, poorly graded; dry, no odor.	15.0	
0.2	100				15	CL		CLAY: moderate brown (5YR 4/4); moderate to high plasticity no odor.	20.0	
0.0	100				20	SW		SAND WITH GRAVEL: light brown (5YR 5/6); 50% sand, fine to medium grained, well graded, subangular to subrounded; 25% gravel, well graded; 25% cobbles, subangular to subrounded, maximum diameter of 4 inches.	25.0	
0.1	100				25	GC		CLAYEY GRAVEL: moderate brown (5YR 4/4); 50% gravel, well graded, 30% sandy clay, moderate plasticity; 20% cobbles, subangular to subrounded, maximum diameter of 4 inches; dry, no odor.	30.0	
0.5	40				30	CL		CLAY: moderate brown (5YR 4/4); sticky, moderate to high plasticity; dry, no odor.	35.0	

Continued Next Page



2295 Gateway Oaks
Suite 240
Sacramento, CA 95833
(916) 567-9900

BORING/WELL CONSTRUCTION LOG

PROJECT NUMBER 56111-6169.001.TK5.MOBIL BORING/WELL NUMBER CDM-P3
PROJECT NAME Aerojet - GEDIT DATE DRILLED 10/23/07

Continued from Previous Page

PID (ppm)	BLOW COUNTS	RECOVERY (inches)	SAMPLE ID.	EXTENT	DEPTH (ft. bgs)	U.S.C.S.	GRAPHIC LOG	LITHOLOGIC DESCRIPTION	CONTACT DEPTH	WELL DIAGRAM
0.2		100				CL		CLAY: moderate brown (5YR 4/4); sticky, low to moderate plasticity; dry, no odor.		
0.0		50			40	CL		GRVELLY CLAY: moderate brown (5YR 4/4); 60% sandy clay, low to moderate plasticity, quartz; 40% gravel, well graded, subangular to subrounded, maximum diameter of 2 inches; dry, no odor.	40.0	
0.6		50			45	GW		GRAVEL WITH SAND: moderate brown (5YR 4/4); 60% gravel, well graded, subangular to angular, maximum diameter of 3 inches; 40% silty sand, fine grained, moderately poorly graded, quartz, subrounded to subangular.	45.0	
1.2		50			50			Drill cuttings not collected between 50 and 52 feet below ground surface. Lithology assumed to be same as 40 to 50 feet below ground surface.	52.0	
								Total depth of borehole was 52 feet below ground surface.		
					55					
					60					
					65					
					70					
					75					



2295 Gateway Oaks
Suite 240
Sacramento, CA 95833
(916) 567-9900

BORING/WELL CONSTRUCTION LOG

PROJECT NUMBER 56111-6169.001.TK5.MOBIL BORING/WELL NUMBER CDM-P4
 PROJECT NAME Aerojet - GEDIT DATE DRILLED 10/29/07
 LOCATION Rancho Cordova, CA CASING TYPE/DIAMETER Poly Tubing/0.25-inch ID
 DRILLING METHOD Sonic SCREEN TYPE/SLOT 0.25-inch Stainless Steel Vapor Probe
 SAMPLING METHOD Continuous Core GRAVEL PACK TYPE No. 3 Monterey Beach Sand
 GROUND SURFACE ELEVATION (FT MSL) NA GROUT TYPE/QUANTITY Portland Type I/II Cement
 TOP OF CASING ELEVATION (FT MSL) NA STATIC WATER LEVEL (FT BELOW TOC) NA
 LOGGED BY K. Hopfensperger GROUND WATER ELEVATION (FT MSL) _____
 REMARKS _____

PID (ppm)	BLOW COUNTS	RECOVERY (inches)	SAMPLE ID.	EXTENT	DEPTH (ft. bgs)	U.S.C.S.	GRAPHIC LOG	LITHOLOGIC DESCRIPTION	CONTACT DEPTH	WELL DIAGRAM
						SP		SAND: moderate brown (5YR 4/4); dry, no odor.		
0.0		100			5	SP		SAND: light brown (5YR 5/6); trace very fine grained quartz; dry, no odor.	4.0	
0.1		100			10			CLAY: dark yellowish orange(10YR 6/6); moderate plasticity, trace fine grained subangular quartz; dry.	9.0	
0.0		100			15	CL				
0.0		100			20					
0.0		100			25					
0.0		100			26.0			SAND WITH GRAVEL: light brown (5YR 5/6); 50% clayey sand, fine grained, subrounded to subangular, quartz; 50% gravel to cobbles, well graded, maximum diameter of 4 inches, subrounded to subangular; dry, no odor.	26.0	
0.0		100			30	SP				
					35				35.0	

Continued Next Page

NEWGINT_SAC_AEROJET_120908.GPJ NEWGINT.GDT 11/13/09



2295 Gateway Oaks
Suite 240
Sacramento, CA 95833
(916) 567-9900

BORING/WELL CONSTRUCTION LOG

PROJECT NUMBER 56111-6169.001.TK5.MOBIL BORING/WELL NUMBER CDM-P4
PROJECT NAME Aerojet - GEDIT DATE DRILLED 10/29/07

Continued from Previous Page

PID (ppm)	BLOW COUNTS	RECOVERY (inches)	SAMPLE ID.	EXTENT	DEPTH (ft. bgs)	U.S.C.S.	GRAPHIC LOG	LITHOLOGIC DESCRIPTION	CONTACT DEPTH	WELL DIAGRAM
0.0		100				CL		CLAY: moderate brown (5YR 4/4); soft, low to moderate plasticity; dry, no odor.		
0.1		70			40	CL		CLAY WITH GRAVEL: moderate brown (5YR 4/4); 80% sandy clay, moderate plasticity; 20% gravel, subangular to angular, maximum diameter of 3 inches; dry, no odor.	41.0	
0.4		70			45	CL			46.0	
					50	SW		SAND WITH GRAVEL: pale yellowish brown (10YR 6/2); 60% sand, fine to medium grained, well graded, subangular, abundant quartz; 40% gravel, well graded, subrounded to subangular, maximum diameter of 3 inches.		
0.0		70			50			Drill cuttings not collected between 50 and 51.5 feet below ground surface. Lithology assumed to be same as 46 to 50 feet below ground surface.	51.5	
					55			Total depth of borehole was 51.5 feet below ground surface.		
					60					
					65					
					70					
					75					

NEWGINT_SAC_AEROJET_120908.GPJ_NEWGINT.GDT 11/13/09



2295 Gateway Oaks
Suite 240
Sacramento, CA 95833
(916) 567-9900

BORING/WELL CONSTRUCTION LOG

PROJECT NUMBER 56111-6169.001.TK5.MOBIL
 PROJECT NAME Aerojet - GEDIT
 LOCATION Rancho Cordova, CA
 DRILLING METHOD Sonic
 SAMPLING METHOD Continuous Core
 GROUND SURFACE ELEVATION (FT MSL) NA
 TOP OF CASING ELEVATION (FT MSL) NA
 LOGGED BY K. Hopfensperger
 REMARKS _____

BORING/WELL NUMBER CDM-P5
 DATE DRILLED 10/24/07
 CASING TYPE/DIAMETER Poly Tubing/0.25-inch ID
 SCREEN TYPE/SLOT 0.25-inch Stainless Steel Vapor Probe
 GRAVEL PACK TYPE No. 3 Monterey Beach Sand
 GROUT TYPE/QUANTITY Portland Type I/II Cement
 STATIC WATER LEVEL (FT BELOW TOC) NA
 GROUND WATER ELEVATION (FT MSL) _____

PID (ppm)	BLOW COUNTS	RECOVERY (inches)	SAMPLE ID.	EXTENT	DEPTH (ft. bgs)	U.S.C.S.	GRAPHIC LOG	LITHOLOGIC DESCRIPTION	CONTACT DEPTH	WELL DIAGRAM
					5	CL		CLAY: moderate brown (5YR 3/4); silty, low to moderate plasticity; dry, no odor.	5.0	
0.0	100				10			CLAY: moderate brown (5YR 4/4); moderate to high plasticity, trace fine grained quartz; dry, no odor.		
0.0	100				15	CL				
0.0	100				20					
0.0	30				20					
0.0	30				20					
0.1	30				25	CL		CLAY: moderate brown (5YR 4/4); moderate to high plasticity, firm; dry, no odor.	25.0	
0.2	60				30	SW		SAND WITH GRAVEL: dark yellowish brown (10YR 2/2); 50% silty sand, fine to medium grained, well graded, subrounded to subangular; 50% gravel, subrounded to subangular, maximum diameter of 3 inches; dry, no odor.	30.0	
					30					
					30					
					35				35.0	

Continued Next Page



2295 Gateway Oaks
Suite 240
Sacramento, CA 95833
(916) 567-9900

BORING/WELL CONSTRUCTION LOG

PROJECT NUMBER 56111-6169.001.TK5.MOBIL BORING/WELL NUMBER CDM-P5
PROJECT NAME Aerojet - GEDIT DATE DRILLED 10/24/07

Continued from Previous Page

PID (ppm)	BLOW COUNTS	RECOVERY (inches)	SAMPLE ID.	EXTENT	DEPTH (ft. bgs)	U.S.C.S.	GRAPHIC LOG	LITHOLOGIC DESCRIPTION	CONTACT DEPTH	WELL DIAGRAM
0.2		60				CL		CLAY: moderate brown (5YR 4/4); moderate to high plasticity, firm; dry, no odor.		
0.0		100			40	SC		CLAYEY SAND: moderate brown (5YR 4/4); 100% clayey sand, low plasticity; dry, no odor.	40.0	
0.0		100			45	SP		SAND WITH GRAVEL: moderate brown (5YR 4/4); 60% silty sand, moderately poorly graded, fine grained, subangular; 40% cobbles, subangular to subrounded, maximum diameter of 4 inches; dry, no odor.	45.0	
0.0		100			50			Drill cuttings not collected between 50 and 51.5 feet below ground surface. Lithology assumed to be same as 45 to 50 feet below ground surface.	51.5	
								Total depth of borehole was 51.5 feet below ground surface.		
					55					
					60					
					65					
					70					
					75					

NEWGINT_SAC_AEROJET_120908.GPJ_NEWGINT.GDT 11/13/09



2295 Gateway Oaks
Suite 240
Sacramento, CA 95833
(916) 567-9900

BORING/WELL CONSTRUCTION LOG

PROJECT NUMBER 56111-6169.001.TK5.MOBIL BORING/WELL NUMBER CDM-P6
 PROJECT NAME Aerojet - GEDIT DATE DRILLED 10/22/07
 LOCATION Rancho Cordova, CA CASING TYPE/DIAMETER Poly Tubing/0.25-inch ID
 DRILLING METHOD Sonic SCREEN TYPE/SLOT 0.25-inch Stainless Steel Vapor Probe
 SAMPLING METHOD Continuous Core GRAVEL PACK TYPE No. 3 Monterey Beach Sand
 GROUND SURFACE ELEVATION (FT MSL) NA GROUT TYPE/QUANTITY Portland Type I/II Cement
 TOP OF CASING ELEVATION (FT MSL) NA STATIC WATER LEVEL (FT BELOW TOC) NA
 LOGGED BY K. Hopfensperger GROUND WATER ELEVATION (FT MSL) _____
 REMARKS _____

PID (ppm)	BLOW COUNTS	RECOVERY (inches)	SAMPLE ID.	EXTENT	DEPTH (ft. bgs)	U.S.C.S.	GRAPHIC LOG	LITHOLOGIC DESCRIPTION	CONTACT DEPTH	WELL DIAGRAM
					5	ML		SILT: light brown (5YR 5/6); low plasticity; dry, no odor.	5.0	<p>Cement Grout (0-15 ft bgs)</p> <p>Poly Tubing (0-38, and 0-48 ft bgs)</p> <p>Bentonite (15-20 ft bgs)</p> <p>Sand (20-30 ft bgs)</p> <p>Bentonite (30-37 ft bgs)</p>
0.0		NM			10	CL		CLAY: moderate brown (5YR 4/4); moderate plasticity; dry, no odor.	10.0	
0.6		NM			15	GC		CLAYEY GRAVEL: light brown (5YR 5/6); 60% gravel, well graded, maximum diameter 2 inches, rounded to subrounded; 40% clay, moderate to high plasticity; dry, no odor.	15.0	
0.7		NM			20	CL		CLAY WITH GRAVEL: light brown (5YR 5/6); 80% clay, moderate to high plasticity; 20% gravel, well graded, maximum diameter 2 inches, rounded to subrounded; dry, no odor.	20.0	
0.2		NM			25	GW		GRAVEL WITH SAND: light brown (5YR 5/6); 75% gravel, well graded, angular to subangular, maximum diameter of 3 inches; 25% silty sand, fine to medium grained, well graded, subangular.	25.0	
2.7		NM			30	SP		SAND WITH GRAVEL: light brown (5YR 5/6); 60% silty sand, fine to medium grained, poorly graded, subangular; 40% gravel, subrounded to subangular, maximum diameter of 2 inches.	30.0	
2.5		NM			35	CL		CLAY WITH GRAVEL: light brown (5YR 5/6); 70% clay, moderate plasticity; 30% cobbles, subangular, maximum diameter of 4 inches; dry, no odor.	35.0	

Continued Next Page

NEWGINT_SAC_AEROJET_120908.GPJ_NEWGINT.GDT 11/13/09



2295 Gateway Oaks
Suite 240
Sacramento, CA 95833
(916) 567-9900

BORING/WELL CONSTRUCTION LOG

PROJECT NUMBER 56111-6169.001.TK5.MOBIL BORING/WELL NUMBER CDM-P6
PROJECT NAME Aerojet - GEDIT DATE DRILLED 10/22/07

Continued from Previous Page

PID (ppm)	BLOW COUNTS	RECOVERY (inches)	SAMPLE ID.	EXTENT	DEPTH (ft. bgs)	U.S.C.S.	GRAPHIC LOG	LITHOLOGIC DESCRIPTION	CONTACT DEPTH	WELL DIAGRAM
0.2		NM				GM		SILTY GRAVEL: moderate brown (5YR 4/4); 50% gravel, subrounded to subangular, maximum diameter of 3 inches; 50% silt, low to moderate plasticity.		<ul style="list-style-type: none"> ← Sand (37-39 ft bgs) ← Vapor Probe (38-38.5 ft bgs) ← Bentonite (39-46.5 ft bgs) ← Poly Tubing (0-38, and 0-48 ft bgs) ← Sand (46.5-50 ft bgs) ← Vapor Probe (48-48.5 ft bgs)
0.0		NM			40	SW		SAND WITH GRAVEL: moderate brown (5YR 4/4); 70% silty sand, fine grained, well graded, subangular to subrounded; 30% gravel, well graded, subangular, maximum diameter of 3 inches.	40.0	
0.2		NM			45	SW		SAND: moderate brown (5YR 4/4); 90% silty sand, fine to coarse, well graded, rounded to angular, quartz; 10% gravel, subrounded to subangular, maximum diameter of 1 inch.	45.0	
0.0		NM			50			Total depth of borehole was 50 feet below ground surface.	50.0	
					55					
					60					
					65					
					70					
					75					

NEWGINT_SAC_AEROJET_120908.GPJ_NEWGINT.GDT 11/13/09



2295 Gateway Oaks
Suite 240
Sacramento, CA 95833
(916) 567-9900

BORING/WELL CONSTRUCTION LOG

PROJECT NUMBER 56111-6169.001.TK5.MOBIL BORING/WELL NUMBER CDM-P6A
 PROJECT NAME Aerojet - GEDIT DATE DRILLED 10/24/07
 LOCATION Rancho Cordova, CA CASING TYPE/DIAMETER Poly Tubing/0.25-inch ID
 DRILLING METHOD Sonic SCREEN TYPE/SLOT 0.25-inch Stainless Steel Vapor Probe
 SAMPLING METHOD Continuous Core GRAVEL PACK TYPE No. 3 Monterey Beach Sand
 GROUND SURFACE ELEVATION (FT MSL) NA GROUT TYPE/QUANTITY Portland Type I/II Cement
 TOP OF CASING ELEVATION (FT MSL) NA STATIC WATER LEVEL (FT BELOW TOC) NA
 LOGGED BY K. Hopfensperger GROUND WATER ELEVATION (FT MSL) _____
 REMARKS _____

PID (ppm)	BLOW COUNTS	RECOVERY (inches)	SAMPLE ID.	EXTENT	DEPTH (ft. bgs)	U.S.C.S.	GRAPHIC LOG	LITHOLOGIC DESCRIPTION	CONTACT DEPTH	WELL DIAGRAM
					5.0	ML		SILT: light brown (5YR 5/6); low plasticity; dry, no odor.		
0.0			NM		5.0	CL		CLAY: moderate brown (5YR 4/4); moderate plasticity; dry, no odor.	5.0	Cement Grout (0-12 ft bgs)
0.6			NM		10.0	GC		CLAYEY GRAVEL: light brown (5YR 5/6); 60% gravel, well graded, maximum diameter 2 inches, rounded to subrounded; 40% clay, moderate to high plasticity; dry, no odor.	10.0	Poly Tubing (0-18, and 0-28 ft bgs)
0.7			NM		15.0	CL		CLAY WITH GRAVEL: light brown (5YR 5/6); 80% clay, moderate to high plasticity; 20% gravel, well graded, maximum diameter 2 inches, rounded to subrounded; dry, no odor.	15.0	Bentonite (12-17 ft bgs)
0.2			NM		20.0	GW		GRAVEL WITH SAND: light brown (5YR 5/6); 75% gravel, well graded, angular to subangular, maximum diameter of 3 inches; 25% silty sand, fine to medium grained, well graded, subangular.	20.0	Sand (17-19.5 ft bgs) Vapor Probe (18-18.5 ft bgs) Bentonite (19.5-27 ft bgs)
2.7			NM		25.0	SP		SAND WITH GRAVEL: light brown (5YR 5/6); 60% silty sand, fine to medium grained, poorly graded, subangular; 40% gravel, subrounded to subangular, maximum diameter of 2 inches.	25.0	Sand (27-30.5 ft bgs) Vapor Probe (28-28.5 ft bgs)
2.5			NM		30.0	CL		CLAY WITH GRAVEL: light brown (5YR 5/6); 70% clay, moderate plasticity; 30% cobbles, subangular, maximum diameter of 4 inches; dry, no odor. Total depth of borehole was 30.5 feet below ground surface.	30.0 30.5	
					35.0					

NEWGINT_SAC_AEROJET_120908.GPJ NEWGINT.GDT 11/13/09



2295 Gateway Oaks
Suite 240
Sacramento, CA 95833
(916) 567-9900

BORING/WELL CONSTRUCTION LOG

PROJECT NUMBER 56111-6169.001.TK5.MOBIL BORING/WELL NUMBER CDM-P7
 PROJECT NAME Aerojet - GEDIT DATE DRILLED 10/16/07
 LOCATION Rancho Cordova, CA CASING TYPE/DIAMETER Poly Tubing/0.25-inch ID
 DRILLING METHOD Sonic SCREEN TYPE/SLOT 0.25-inch Stainless Steel Vapor Probe
 SAMPLING METHOD Continuous Core GRAVEL PACK TYPE No. 3 Monterey Beach Sand
 GROUND SURFACE ELEVATION (FT MSL) NA GROUT TYPE/QUANTITY Portland Type I/II Cement
 TOP OF CASING ELEVATION (FT MSL) NA STATIC WATER LEVEL (FT BELOW TOC) NA
 LOGGED BY K. Hopfensperger GROUND WATER ELEVATION (FT MSL) _____
 REMARKS _____

PID (ppm)	BLOW COUNTS	RECOVERY (inches)	SAMPLE ID.	EXTENT	DEPTH (ft. bgs)	U.S.C.S.	GRAPHIC LOG	LITHOLOGIC DESCRIPTION	CONTACT DEPTH	WELL DIAGRAM
						ML		SILT: light brown (5YR 5/6); low plasticity, fine grained; <5% subangular gravel; dry, no odor.		
42		NM			5			SILT: moderate brown (5YR 4/4); fine grained, moderate to high plasticity; dry, no odor.	5.0	
162		NM			10	ML				
211		NM			15	GM		SILTY GRAVEL: moderate yellowish brown (10YR 5/4); 60% gravel, well graded, subangular to angular, maximum diameter of 2 inches; 40% silt, low plasticity to non-plastic.	15.0	
63		NM			20	GM		SILTY GRAVEL: moderate yellowish brown (10YR 5/4); 70% gravel, well graded, subangular to angular, maximum diameter of 2 inches; 30% silt, low to moderate plasticity; no odor.	20.0	
74		NM			25	CL		CLAY WITH GRAVEL: moderate brown (5YR 4/4); 70% clay, silty, soft, moderate plasticity; 30% gravel, subangular to angular, maximum diameter of 2 inches; moist.	25.0	
86		NM			30	SP		SAND WITH GRAVEL: moderate yellowish brown (10YR 5/4); 70% sand, fine grained, moderately poorly graded, subangular; 25% gravel, subrounded to subangular, maximum diameter of 1 inch; 5% silt; dry, no odor.	30.0	
					35				35.0	

Continued Next Page

NEWGINT_SAC_AEROJET_120908.GPJ NEWGINT.GDT 11/13/09



2295 Gateway Oaks
Suite 240
Sacramento, CA 95833
(916) 567-9900

BORING/WELL CONSTRUCTION LOG

PROJECT NUMBER 56111-6169.001.TK5.MOBIL BORING/WELL NUMBER CDM-P7
PROJECT NAME Aerojet - GEDIT DATE DRILLED 10/16/07

Continued from Previous Page

PID (ppm)	BLOW COUNTS	RECOVERY (inches)	SAMPLE ID.	EXTENT	DEPTH (ft. bgs)	U.S.C.S.	GRAPHIC LOG	LITHOLOGIC DESCRIPTION	CONTACT DEPTH	WELL DIAGRAM
68		NM						SAND WITH GRAVEL: moderate yellowish brown (10YR 5/4); 70% sand, fine grained, moderately poorly graded, subangular; 20% gravel, subrounded to subangular, maximum diameter of 1 inch; 10% silt; dry, no odor.		
28		NM			40	SP	40 - 50 feet bgs no returns; well drilled to 50 feet bgs; potential void from 50 - 62 feet bgs (void filled using #3 sand filter).	40.0		
NM		NM			45					
NM		NM			50					
					55					
					60					
					65					
					70					
					75					
								Total depth of borehole was 62 feet below ground surface.	62.0	

NEWGINT_SAC_AEROJET_120908.GPJ_NEWGINT.GDT 11/13/09



2295 Gateway Oaks
Suite 240
Sacramento, CA 95833
(916) 567-9900

BORING/WELL CONSTRUCTION LOG

PROJECT NUMBER 56111-6169.001.TK5.MOBIL BORING/WELL NUMBER CDM-P8
 PROJECT NAME Aerojet - GEDIT DATE DRILLED 10/11/07-10/12/07
 LOCATION Rancho Cordova, CA CASING TYPE/DIAMETER Poly Tubing/0.25-inch ID
 DRILLING METHOD Sonic SCREEN TYPE/SLOT 0.25-inch Stainless Steel Vapor Probe
 SAMPLING METHOD Continuous Core GRAVEL PACK TYPE No. 3 Monterey Beach Sand
 GROUND SURFACE ELEVATION (FT MSL) NA GROUT TYPE/QUANTITY Portland Type I/II Cement
 TOP OF CASING ELEVATION (FT MSL) NA STATIC WATER LEVEL (FT BELOW TOC) NA
 LOGGED BY K. Hopfensperger GROUND WATER ELEVATION (FT MSL) _____
 REMARKS _____

PID (ppm)	BLOW COUNTS	RECOVERY (inches)	SAMPLE ID.	EXTENT	DEPTH (ft. bgs)	U.S.C.S.	GRAPHIC LOG	LITHOLOGIC DESCRIPTION	CONTACT DEPTH	WELL DIAGRAM
15.1		NM			5	CL		CLAY: moderate brown (5YR 5/6); moderate to high plasticity; dry, no odor.	5.0	<p> Cement Grout (0-14 ft bgs) Poly Tubing (0-18, 0-28, 0-38, and 0-48 ft bgs) Bentonite (14-16.5 ft bgs) Sand (16.5-19.5 ft bgs) Bentonite (19.5-27 ft bgs) Sand (27-29.5 ft bgs) Vapor Probe (28-28.5 ft bgs) Bentonite (29.5-36.5 ft bgs) </p>
		NM				CL		CLAY: moderate brown (5YR 5/6); high plasticity; dry, no odor.		
55.9		NM			10			GRAVEL WITH SAND: moderate brown (5YR 5/6); 60% gravel, well graded, subangular to angular, maximum diameter of 2 inches; 40% sand, medium grained, poorly graded, subangular to angular.	10.0	
10.8		NM			15	GW			15.0	
NM		NM			20			No returns 20 - 25 feet bgs.	20.0	
NM		NM			25	GC		CLAYEY GRAVEL WITH SAND: moderate brown (5YR 5/6); 40% gravel, well graded, subangular to angular, maximum diameter of 2 inches; 30% sand, medium grained, poorly sorted, subangular to angular; 30% clay, high plasticity; dry, no odor.	25.0	
110		NM			30	GP		GRAVEL WITH SAND: moderate brown (5YR 5/6); 80% gravel, poorly graded, maximum diameter of 2 inches, subrounded to subangular; 20% sand, fine to medium grained, subangular to angular.	30.0	
					35				35.0	

Continued Next Page



2295 Gateway Oaks
Suite 240
Sacramento, CA 95833
(916) 567-9900

BORING/WELL CONSTRUCTION LOG

PROJECT NUMBER 56111-6169.001.TK5.MOBIL BORING/WELL NUMBER CDM-P8
PROJECT NAME Aerojet - GEDIT DATE DRILLED 10/11/07-10/12/07

Continued from Previous Page

PID (ppm)	BLOW COUNTS	RECOVERY (inches)	SAMPLE ID.	EXTENT	DEPTH (ft. bgs)	U.S.C.S.	GRAPHIC LOG	LITHOLOGIC DESCRIPTION	CONTACT DEPTH	WELL DIAGRAM
14.2		NM						GRAVEL WITH CLAY: moderate brown (5YR 5/6); 85% gravel, subangular, maximum diameter of 2 inches; 15% clay, soft, low to moderate plasticity; slightly moist.		
217		NM		40	GP-GC		SAND WITH CLAY: moderate brown (5YR 5/6); 90% sand, medium to coarse grained, subangular, moderately poorly graded; 10% clay, soft, low to moderate plasticity; slightly moist.	40.0		
180		NM		45	SP-SC		GRAVEL WITH SAND: dark yellowish brown (10YR 4/2); 50% gravel, poorly graded, angular, maximum diameter of 2 inches, abundant chert; 50% sand, coarse grained, moderately poorly graded, subrounded to subangular.	45.0		
184		NM		50	GW		Total depth of borehole was 50 feet below ground surface.	50.0		
					55					
					60					
					65					
					70					
					75					

NEWGINT_SAC_AEROJET_120908.GPJ_NEWGINT.GDT 11/13/09



2295 Gateway Oaks
Suite 240
Sacramento, CA 95833
(916) 567-9900

BORING/WELL CONSTRUCTION LOG

PROJECT NUMBER 56111-6169.001.TK5.MOBIL BORING/WELL NUMBER CDM-P8A
 PROJECT NAME Aerojet - GEDIT DATE DRILLED 10/15/07
 LOCATION Rancho Cordova, CA CASING TYPE/DIAMETER Poly Tubing/0.25-inch ID
 DRILLING METHOD Sonic SCREEN TYPE/SLOT 0.25-inch Stainless Steel Vapor Probe
 SAMPLING METHOD Continuous Core GRAVEL PACK TYPE No. 3 Monterey Beach Sand
 GROUND SURFACE ELEVATION (FT MSL) NA GROUT TYPE/QUANTITY Portland Type I/II Cement
 TOP OF CASING ELEVATION (FT MSL) NA STATIC WATER LEVEL (FT BELOW TOC) NA
 LOGGED BY K. Hopfensperger GROUND WATER ELEVATION (FT MSL) _____
 REMARKS _____

PID (ppm)	BLOW COUNTS	RECOVERY (inches)	SAMPLE ID.	EXTENT	DEPTH (ft. bgs)	U.S.C.S.	GRAPHIC LOG	LITHOLOGIC DESCRIPTION	CONTACT DEPTH	WELL DIAGRAM
15.1		NM			5	CL		CLAY: moderate brown (5YR 5/6); moderate to high plasticity; dry, no odor.	5.0	<p>Cement Grout (0-14 ft bgs)</p> <p>Poly Tubing (0-18 ft bgs)</p> <p>Bentonite (14-17 ft bgs)</p> <p>Sand (17-20.5 ft bgs)</p> <p>Vapor Probe (18-18.5 ft bgs)</p>
						CL		CLAY: moderate brown (5YR 5/6); high plasticity; dry, no odor.		
55.9		NM			10			GRAVEL WITH SAND: moderate brown (5YR 5/6); 60% gravel, well graded, subangular to angular, maximum diameter of 2 inches; 40% sand, medium grained, poorly graded, subangular to angular.	10.0	
10.8		NM			15	GW				
NM		NM			20			No returns. Total depth of borehole was 20.5 feet below ground surface.	20.0 20.5	
					25					
					30					
					35					

NEWGINT_SAC_AEROJET_120908.GPJ NEWGINT.GDT 11/13/09



2295 Gateway Oaks
Suite 240
Sacramento, CA 95833
(916) 567-9900

BORING/WELL CONSTRUCTION LOG

PROJECT NUMBER 56111-6169.001.TK5.MOBIL BORING/WELL NUMBER CDM-CB-1
 PROJECT NAME Aerojet - GEDIT DATE DRILLED 04/18/08
 LOCATION Rancho Cordova, CA CASING TYPE/DIAMETER NA
 DRILLING METHOD Sonic SCREEN TYPE/SLOT NA
 SAMPLING METHOD Continuous Core GRAVEL PACK TYPE NA
 GROUND SURFACE ELEVATION (FT MSL) NA GROUT TYPE/QUANTITY Bentonite Grout
 TOP OF CASING ELEVATION (FT MSL) NA STATIC WATER LEVEL (FT BELOW TOC) NA
 LOGGED BY K. Hopfensperger GROUND WATER ELEVATION (FT MSL) _____
 REMARKS _____

PID (ppm)	BLOW COUNTS	RECOVERY (inches)	SAMPLE ID.	EXTENT	DEPTH (ft. bgs)	U.S.C.S.	GRAPHIC LOG	LITHOLOGIC DESCRIPTION	CONTACT DEPTH	WELL DIAGRAM
1.5	100				5	CL		CLAY: light brown (5YR 5/6); 100% clay, silty, moderate plasticity; dry, no odor.		No well constructed. Borehole abandoned with bentonite grout.
2.2	100				10					
4.2	100				15	CL		CLAY: moderate brown (5YR 4/4); 100% clay, silty, soft, low plasticity; dry, no odor.	12.0	
1.4	100				20	GC		CLAYEY GRAVEL: moderate brown (5YR 4/4); 60% gravel, well graded, fine to coarse grained, maximum diameter of 2 inches; 40% clay, silty, soft, low plasticity; dry, no odor.	18.0	
					21.0	ML		SILT: moderate brown (5YR 4/4); 100% silt, low to moderate plasticity; dry, no odor.	21.0	
1.5	100				25	GW		GRAVEL WITH SAND: moderate brown (5YR 4/4); 50% gravel, well graded, fine to coarse grained, maximum diameter of 4 inches, subrounded to subangular; 50% sand, well graded, fine to medium grained, subangular to angular.	23.0	
2.2	100				30	CL		CLAY: moderate brown (5YR 4/4); 100% clay, silty, soft, low plasticity; dry, no odor.	30.0	
					35			GRAVEL WITH SAND: moderate brown (5YR 4/4); 60% gravel, well graded, fine to coarse grained, maximum diameter of 4 inches, subrounded to subangular; 40%	33.0	

Continued Next Page

NEWGINT_SAC_AEROJET_120908.GPJ NEWGINT.GDT 11/13/09



2295 Gateway Oaks
Suite 240
Sacramento, CA 95833
(916) 567-9900

BORING/WELL CONSTRUCTION LOG

PROJECT NUMBER 56111-6169.001.TK5.MOBIL BORING/WELL NUMBER CDM-CB-1
PROJECT NAME Aerojet - GEDIT DATE DRILLED 04/18/08

Continued from Previous Page

PID (ppm)	BLOW COUNTS	RECOVERY (inches)	SAMPLE ID.	EXTENT	DEPTH (ft. bgs)	U.S.C.S.	GRAPHIC LOG	LITHOLOGIC DESCRIPTION	CONTACT DEPTH	WELL DIAGRAM
2.4		100						sand, well graded, fine to medium grained, subangular to angular; dry, no odor.		
2.6		100			40	GW				
2.8		100			45					
					46.0	SM		SILTY SAND: moderate brown (5YR 3/4); 100% silty sand, soft, moderately well graded, fine to coarse grained, rounded to subrounded; slightly moist, no odor.	47.0	
					50.0	GW		GRAVEL WITH SAND: moderate brown (5YR 4/4); 60% gravel, well graded, fine to coarse grained, maximum diameter of 4 inches, subrounded to subangular; 40% sand, well graded, fine to medium grained, subangular to angular; dry, no odor.	50.0	
3.0		100						Total depth of borehole was 50.0 feet below ground surface.		
					55					
					60					
					65					
					70					
					75					

NEWGINT_SAC_AEROJET_120908.GPJ_NEWGINT.GDT 11/13/09



2295 Gateway Oaks
Suite 240
Sacramento, CA 95833
(916) 567-9900

BORING/WELL CONSTRUCTION LOG

PROJECT NUMBER 56111-6169.001.TK5.MOBIL BORING/WELL NUMBER CDM-CB-2
 PROJECT NAME Aerojet - GEDIT DATE DRILLED 04/18/08
 LOCATION Rancho Cordova, CA CASING TYPE/DIAMETER NA
 DRILLING METHOD Sonic SCREEN TYPE/SLOT NA
 SAMPLING METHOD Continuous Core GRAVEL PACK TYPE NA
 GROUND SURFACE ELEVATION (FT MSL) NA GROUT TYPE/QUANTITY Bentonite Grout
 TOP OF CASING ELEVATION (FT MSL) NA STATIC WATER LEVEL (FT BELOW TOC) NA
 LOGGED BY K. Hopfensperger GROUND WATER ELEVATION (FT MSL) _____
 REMARKS _____

PID (ppm)	BLOW COUNTS	RECOVERY (inches)	SAMPLE ID.	EXTENT	DEPTH (ft. bgs)	U.S.C.S.	GRAPHIC LOG	LITHOLOGIC DESCRIPTION	CONTACT DEPTH	WELL DIAGRAM
					5	ML		SILT: moderate brown (5YR 4/4); 100% silt, firm; dry, no odor.	5.0	No well constructed. Borehole abandoned with bentonite grout.
2.2		100			5	CL		CLAY: moderate brown (5YR 4/4); 100% clay, silty, soft, low plasticity; slightly moist, no odor.	7.0	
					10	ML		SILT: moderate brown (5YR 4/4); 100% silt, firm; dry, no odor.	12.0	
					15	SW		SAND WITH GRAVEL: moderate brown (5YR 4/4); 70% sand, well graded, fine to coarse grained; 30% gravel, well graded, medium to coarse grained, subrounded to subangular, maximum diameter of 2 inches; dry, no odor.	15.0	
					15	CL		CLAY: moderate brown (5YR 4/4); 100% clay, soft; dry, no odor.	16.0	
					20	SW		SAND AND GRAVEL: moderate brown (5YR 4/4); 50% sand, well graded, fine to coarse grained; 50% gravel, well graded, medium to coarse grained, subrounded to subangular, maximum diameter of 2 inches; dry, no odor.		
1.7		100			20	SW				
					25	CL		CLAY: moderate brown (5YR 4/4); 100% clay, soft; dry, no odor.	25.0	
6.4		100			25	CL			26.0	
					30	GW		GRAVEL WITH SAND: moderate brown (5YR 4/4); 60% gravel, well graded, fine to coarse grained, maximum diameter of 3 inches, subrounded to subangular; 40% sand, well graded, fine to medium grained, subrounded to subangular; dry, no odor.		
6.2		100			30	ML		SILT: moderate brown (5YR 4/4); 100% silt, firm, non-plastic; dry, no odor.	32.0	
					35			GRAVEL WITH SAND: moderate brown (5YR 3/4); 65% gravel, well graded, fine to coarse grained, maximum	33.0	

Continued Next Page

NEWGINT_SAC_AEROJET_120908.GPJ NEWGINT.GDT 11/13/09



2295 Gateway Oaks
Suite 240
Sacramento, CA 95833
(916) 567-9900

BORING/WELL CONSTRUCTION LOG

PROJECT NUMBER 56111-6169.001.TK5.MOBIL BORING/WELL NUMBER CDM-CB-2
PROJECT NAME Aerojet - GEDIT DATE DRILLED 04/18/08

Continued from Previous Page

PID (ppm)	BLOW COUNTS	RECOVERY (inches)	SAMPLE ID.	EXTENT	DEPTH (ft. bgs)	U.S.C.S.	GRAPHIC LOG	LITHOLOGIC DESCRIPTION	CONTACT DEPTH	WELL DIAGRAM
2.1		100						diameter of 4 inches, subrounded to subangular; 35% sand, well graded, fine to medium grained, subangular; dry, no odor.		
4.6		100			40	GW				
6.7		100			45	ML		SILT: moderate brown (5YR 4/4); 100% silt, firm, non-plastic; dry, no odor.	45.0	
						GW		GRAVEL WITH SAND: moderate brown (5YR 3/4); 65% gravel, well graded, fine to coarse grained, maximum diameter of 4 inches, subrounded to subangular; 35% sand, well graded, fine to medium grained, subangular; dry, no odor.	47.0	
12.5		100			50			Total depth of borehole was 50.0 feet below ground surface.	50.0	
					55					
					60					
					65					
					70					
					75					

NEWGINT_SAC_AEROJET_120908.GPJ NEWGINT.GDT 11/13/09



2295 Gateway Oaks
Suite 240
Sacramento, CA 95833
(916) 567-9900

BORING/WELL CONSTRUCTION LOG

PROJECT NUMBER 56111-6169.001.TK5.MOBIL **BORING/WELL NUMBER** CDM-CB-3
PROJECT NAME Aerojet - GEDIT **DATE DRILLED** 6/10/08
LOCATION Rancho Cordova, CA **CASING TYPE/DIAMETER** NA
DRILLING METHOD Sonic **SCREEN TYPE/SLOT** NA
SAMPLING METHOD Continuous Core **GRAVEL PACK TYPE** NA
GROUND SURFACE ELEVATION (FT MSL) NA **GROUT TYPE/QUANTITY** Bentonite Grout
TOP OF CASING ELEVATION (FT MSL) NA **STATIC WATER LEVEL (FT BELOW TOC)** NA
LOGGED BY K. Hopfensperger **GROUND WATER ELEVATION (FT MSL)** _____
REMARKS _____

PID (ppm)	BLOW COUNTS	RECOVERY (inches)	SAMPLE ID.	EXTENT	DEPTH (ft. bgs)	U.S.C.S.	GRAPHIC LOG	LITHOLOGIC DESCRIPTION	CONTACT DEPTH	WELL DIAGRAM
NM		100			5			CLAY: moderate brown (5YR 4/4); 100% clay, silty, low plasticity; dry, no odor.		No well constructed. Borehole abandoned with bentonite grout.
NM		100			10	CL				
NM		100			15					
NM		100			20	GP		GRAVEL WITH SAND: moderate yellowish brown (10YR 5/4); 60% gravel, poorly graded, maximum diameter of 2 inches, subangular to subrounded; 40% sand, poorly graded, fine to medium grained, subrounded to subangular.	19.0 21.0	
NM		100			25	GP		GRAVEL WITH SAND: moderate brown (5YR 4/4); 60% gravel, poorly graded, maximum diameter of 3 inches, subangular to subrounded; 40% sand, well graded, fine to coarse grained, subrounded to subangular.	23.0 28.0	
NM		100			30	GM		SILTY GRAVEL WITH SAND: moderate brown (5YR 4/4); 50% gravel, poorly graded, maximum diameter of 4 inches, subrounded to subangular; 25% sand, well graded, fine to medium grained, subangular to subrounded; 25% silt, non-plastic; dry.		

Continued Next Page

NEWGINT_SAC_AEROJET_120908.GPJ NEWGINT.GDT 11/13/09





2295 Gateway Oaks
Suite 240
Sacramento, CA 95833
(916) 567-9900

BORING/WELL CONSTRUCTION LOG

PROJECT NUMBER 56111-6169.001.TK5.MOBIL BORING/WELL NUMBER CDM-CB-3
PROJECT NAME Aerojet - GEDIT DATE DRILLED 6/10/08

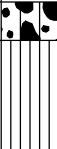
Continued from Previous Page

PID (ppm)	BLOW COUNTS	RECOVERY (inches)	SAMPLE ID.	EXTENT	DEPTH (ft. bgs)	U.S.C.S.	GRAPHIC LOG	LITHOLOGIC DESCRIPTION	CONTACT DEPTH	WELL DIAGRAM
NM		100							36.0	
						ML		SILT WITH GRAVEL: moderate brown (5YR 4/4); 80% silt, non-plastic; 20% gravel, well graded, maximum diameter of 1 inch, subrounded; dry, no odor.	39.0	
NM		100			40			GRAVEL WITH SAND: moderate brown (5YR 4/4); 60% gravel, poorly graded, maximum diameter of 2 inches, subrounded to subangular; 40% sand, well graded, fine to coarse grained, subangular to angular.		
NM		100			45	GP				
NM		100			50			Total depth of borehole was 50.0 feet below ground surface.	50.0	
					55					
					60					
					65					
					70					
					75					

NEWGINT_SAC_AEROJET_120908.GPJ_NEWGINT.GDT 11/13/09



2295 Gateway Oaks
Suite 240
Sacramento, CA 95833
(916) 567-9900

BORING/WELL CONSTRUCTION LOG

PROJECT NUMBER 56111-6169.001.TK5.MOBIL **BORING/WELL NUMBER** CDM-CB-4
PROJECT NAME Aerojet - GEDIT **DATE DRILLED** 6/10/08
LOCATION Rancho Cordova, CA **CASING TYPE/DIAMETER** NA
DRILLING METHOD Sonic **SCREEN TYPE/SLOT** NA
SAMPLING METHOD Continuous Core **GRAVEL PACK TYPE** NA
GROUND SURFACE ELEVATION (FT MSL) NA **GROUT TYPE/QUANTITY** Bentonite Grout
TOP OF CASING ELEVATION (FT MSL) NA **STATIC WATER LEVEL (FT BELOW TOC)** NA
LOGGED BY K. Hopfensperger **GROUND WATER ELEVATION (FT MSL)** _____
REMARKS _____

PID (ppm)	BLOW COUNTS	RECOVERY (inches)	SAMPLE ID.	EXTENT	DEPTH (ft. bgs)	U.S.C.S.	GRAPHIC LOG	LITHOLOGIC DESCRIPTION	CONTACT DEPTH	WELL DIAGRAM
NM		50			5	CL		CLAY: moderate brown (5YR 4/4); 100% clay, silty, low plasticity; dry, no odor.	6.0	No well constructed. Borehole abandoned with bentonite grout.
NM		100			10	CL		CLAY: moderate brown (5YR 4/4); 100% clay, silty, low to moderate plasticity; dry, no odor.	14.0	
NM		100			15	GC		CLAYEY GRAVEL WITH SAND: moderate brown (5YR 4/4); 60% gravel, poorly graded, maximum diameter of 2 inches; 20% clay, silty, low to moderate plasticity; 20% sand, poorly graded, fine to medium grained, subrounded to subangular.	20.0	
NM		100			20	CL		CLAY: moderate brown (5YR 4/4); 100% clay, moderate to high plasticity; dry, no odor.	21.0	
NM		100			25	GC		CLAYEY GRAVEL WITH SAND: moderate brown (5YR 4/4); 50% gravel, poorly graded, maximum diameter of 2 inches; 30% sand, poorly graded, fine to medium grained, subrounded to subangular, 20% clay, silty, low to moderate plasticity.	30.0	
NM		100			30	ML		GRAVELLY SILT: moderate brown (5YR 4/4); 60% silt, non-plastic; 40% gravel, well graded, maximum diameter of 1 inch; dry, no odor.	33.0	
					35			GRAVEL WITH SILT AND SAND: moderate brown (5YR 4/4); 50% gravel, poorly graded, subrounded to angular, maximum diameter of 2 inches; 40% sand, well graded,		

Continued Next Page

NEWGINT_SAC_AEROJET_120908.GPJ NEWGINT.GDT 11/13/09



2295 Gateway Oaks
Suite 240
Sacramento, CA 95833
(916) 567-9900

BORING/WELL CONSTRUCTION LOG

PROJECT NUMBER 56111-6169.001.TK5.MOBIL BORING/WELL NUMBER CDM-CB-4
PROJECT NAME Aerojet - GEDIT DATE DRILLED 6/10/08

Continued from Previous Page

PID (ppm)	BLOW COUNTS	RECOVERY (inches)	SAMPLE ID.	EXTENT	DEPTH (ft. bgs)	U.S.C.S.	GRAPHIC LOG	LITHOLOGIC DESCRIPTION	CONTACT DEPTH	WELL DIAGRAM
NM		100						fine to medium grained, subangular; 10% silt, low plasticity; dry, no odor.		
NM		100			40	GP-GM				
NM		100			45	GM		SILTY GRAVEL WITH SAND: moderate brown (5YR 4/4); 40% gravel, poorly graded, subrounded to angular, maximum diameter of 2 inches; 40% sand, well graded, fine to medium grained, subangular; 20% silt, low plasticity; dry, no odor.	45.0	
NM		100			50			Total depth of borehole was 50.0 feet below ground surface.	50.0	
					55					
					60					
					65					
					70					
					75					

NEWGINT_SAC_AEROJET_120908.GPJ_NEWGINT.GDT 11/13/09



2295 Gateway Oaks
Suite 240
Sacramento, CA 95833
(916) 567-9900

BORING/WELL CONSTRUCTION LOG

PROJECT NUMBER 56111-6169.001.TK5.MOBIL **BORING/WELL NUMBER** CDM-CB-5
PROJECT NAME Aerojet - GEDIT **DATE DRILLED** 7/10/08
LOCATION Rancho Cordova, CA **CASING TYPE/DIAMETER** NA
DRILLING METHOD Sonic **SCREEN TYPE/SLOT** NA
SAMPLING METHOD Continuous Core **GRAVEL PACK TYPE** NA
GROUND SURFACE ELEVATION (FT MSL) NA **GROUT TYPE/QUANTITY** Bentonite Grout
TOP OF CASING ELEVATION (FT MSL) NA **STATIC WATER LEVEL (FT BELOW TOC)** NA
LOGGED BY T.Titus **GROUND WATER ELEVATION (FT MSL)** _____
REMARKS _____

PID (ppm)	BLOW COUNTS	RECOVERY (inches)	SAMPLE ID.	EXTENT	DEPTH (ft. bgs)	U.S.C.S.	GRAPHIC LOG	LITHOLOGIC DESCRIPTION	CONTACT DEPTH	WELL DIAGRAM
NM		100			5	ML		SILT: brown; 100% silt, firm, non-plastic; moist, no odor.		No well constructed. Borehole abandoned with bentonite grout.
NM		100			10	CL		CLAY: reddish brown; 100% clay, firm, moderate plasticity; moist, no odor.	10.0	
NM		100			15			SILTY SAND WITH GRAVEL: 40% sand, well graded, fine to coarse grained, angular to rounded; 30% silt, non-plastic; 30% gravel, well graded, fine and coarse grained, maximum diameter of 3 inches, angular to rounded; trace cobbles, maximum diameter of 6 inches, rounded; moist, no odor.	15.0	
NM		100			20					
NM		100			25	SM				
NM		100			30					
					35				35.0	

Continued Next Page

NEWGINT_SAC_AEROJET_120908.GPJ NEWGINT.GDT 11/13/09



2295 Gateway Oaks
Suite 240
Sacramento, CA 95833
(916) 567-9900

BORING/WELL CONSTRUCTION LOG

PROJECT NUMBER 56111-6169.001.TK5.MOBIL BORING/WELL NUMBER CDM-CB-5
PROJECT NAME Aerojet - GEDIT DATE DRILLED 7/10/08

Continued from Previous Page

PID (ppm)	BLOW COUNTS	RECOVERY (inches)	SAMPLE ID.	EXTENT	DEPTH (ft. bgs)	U.S.C.S.	GRAPHIC LOG	LITHOLOGIC DESCRIPTION	CONTACT DEPTH	WELL DIAGRAM
NM		100						SILTY SAND WITH GRAVEL: 40% sand, well graded, fine to coarse grained, angular to rounded; 30% silt, non-plastic; 30% gravel, well graded, fine and coarse grained, maximum diameter of 3 inches, angular to rounded; trace cobbles, maximum diameter of 6 inches, rounded; moist, no odor.	50.0	
NM		75			40					
NM		75			45	SM				
NM		75			50					
								Total depth of borehole was 50.0 feet below ground surface.		
					55					
					60					
					65					
					70					
					75					

NEWGINT_SAC_AEROJET_120908.GPJ NEWGINT.GDT 11/13/09



2295 Gateway Oaks
Suite 240
Sacramento, CA 95833
(916) 567-9900

BORING/WELL CONSTRUCTION LOG

PROJECT NUMBER 56111-6169.001.TK5.MOBIL **BORING/WELL NUMBER** CDM-CB-6
PROJECT NAME Aerojet - GEDIT **DATE DRILLED** 7/10/08
LOCATION Rancho Cordova, CA **CASING TYPE/DIAMETER** NA
DRILLING METHOD Sonic **SCREEN TYPE/SLOT** NA
SAMPLING METHOD Continuous Core **GRAVEL PACK TYPE** NA
GROUND SURFACE ELEVATION (FT MSL) NA **GROUT TYPE/QUANTITY** Bentonite Grout
TOP OF CASING ELEVATION (FT MSL) NA **STATIC WATER LEVEL (FT BELOW TOC)** NA
LOGGED BY T.Titus **GROUND WATER ELEVATION (FT MSL)** _____
REMARKS _____

PID (ppm)	BLOW COUNTS	RECOVERY (inches)	SAMPLE ID.	EXTENT	DEPTH (ft. bgs)	U.S.C.S.	GRAPHIC LOG	LITHOLOGIC DESCRIPTION	CONTACT DEPTH	WELL DIAGRAM
0	100				5	ML		SILT: brown; 100% silt, soft, non-plastic; dry, no odor.	3.0	No well constructed. Borehole abandoned with bentonite grout.
0	100				10	CL		CLAY: dark yellowish brown; 100% clay, firm, high plasticity; moist, no odor.	10.0	
0	100				15	ML		SILT: brown; 100% silt, firm, low plasticity; moist, no odor.	15.0	
0	100				20	CL		CLAY: dark yellowish brown; 100% clay, firm, high plasticity; moist, no odor.	20.0	
0	100				25	SM		SILTY SAND WITH GRAVEL: 40% sand, well graded, fine to coarse grained, angular to rounded; 30% silt, non-plastic; 30% gravel, well graded, fine and coarse grained, maximum diameter of 3 inches, angular to rounded; trace cobbles, maximum diameter of 6 inches, rounded; moist, no odor.	35.0	
0	100				30					
0	100				35					

Continued Next Page

NEWGINT_SAC_AEROJET_120908.GPJ NEWGINT.GDT 11/13/09



2295 Gateway Oaks
 Suite 240
 Sacramento, CA 95833
 (916) 567-9900

BORING/WELL CONSTRUCTION LOG

PROJECT NUMBER 56111-6169.001.TK5.MOBIL BORING/WELL NUMBER CDM-CB-6
 PROJECT NAME Aerojet - GEDIT DATE DRILLED 7/10/08

Continued from Previous Page

PID (ppm)	BLOW COUNTS	RECOVERY (inches)	SAMPLE ID.	EXTENT	DEPTH (ft. bgs)	U.S.C.S.	GRAPHIC LOG	LITHOLOGIC DESCRIPTION	CONTACT DEPTH	WELL DIAGRAM
0		100				GM		SILTY GRAVEL: brown; 60% gravel, well graded, fine and coarse grained, maximum diameter of 3 inches, angular to rounded; 40% silt, soft, non-plastic; moist, no odor.	40.0	
0		100			40			SILTY SAND WITH GRAVEL: 40% sand, well graded, fine to coarse grained, angular to rounded; 30% silt, non-plastic; 30% gravel, well graded, fine and coarse grained, maximum diameter of 3 inches, angular to rounded; trace cobbles, maximum diameter of 6 inches, rounded; moist, no odor.		
0		100			45	SM				
0		100			50			Total depth of borehole was 50.0 feet below ground surface.	50.0	
					55					
					60					
					65					
					70					
					75					

NEWGINT_SAC_AEROJET_120908.GPJ_NEWGINT.GDT 11/13/09



2295 Gateway Oaks
Suite 240
Sacramento, CA 95833
(916) 567-9900

BORING/WELL CONSTRUCTION LOG

PROJECT NUMBER 56111-6169.001.TK5.MOBIL BORING/WELL NUMBER CDM-CB-7
 PROJECT NAME Aerojet - GEDIT DATE DRILLED 9/2/08
 LOCATION Rancho Cordova, CA CASING TYPE/DIAMETER NA
 DRILLING METHOD Sonic SCREEN TYPE/SLOT NA
 SAMPLING METHOD Continuous Core GRAVEL PACK TYPE NA
 GROUND SURFACE ELEVATION (FT MSL) NA GROUT TYPE/QUANTITY Bentonite Grout
 TOP OF CASING ELEVATION (FT MSL) NA STATIC WATER LEVEL (FT BELOW TOC) NA
 LOGGED BY K. Hopfensperger GROUND WATER ELEVATION (FT MSL) _____
 REMARKS _____

PID (ppm)	BLOW COUNTS	RECOVERY (inches)	SAMPLE ID.	EXTENT	DEPTH (ft. bgs)	U.S.C.S.	GRAPHIC LOG	LITHOLOGIC DESCRIPTION	CONTACT DEPTH	WELL DIAGRAM
NM	100				5	CL		CLAY: moderate brown (5YR 4/4); 100% clay, silyt, soft, moderate to high plasticity; slightly moist, no odor.		No well constructed. Borehole abandoned with bentonite grout.
NM	100				10	CL				
NM	100				15	CL				
NM	100				20	CL		CLAY WITH GRAVEL: moderate brown (5YR 4/4); 90% clay, soft, moderate to high plasticity; 10% gravel, well graded, medium and coarse grained, maximum diameter of 2 inches, subrounded to subangular; slightly moist, no odor.	16.0	
NM	100				25	CL		GRAVELLY CLAY: moderate brown (5YR 4/4); 60% clay, soft, high plasticity; 40% gravel, well graded, fine to coarse grained, maximum diameter of 2 inches, subrounded to subangular; dry, no odor.	20.0	
NM	50				30	CL				
					35				35.0	

Continued Next Page

NEWGINT_SAC_AEROJET_120908.GPJ NEWGINT.GDT 11/13/09





2295 Gateway Oaks
Suite 240
Sacramento, CA 95833
(916) 567-9900

BORING/WELL CONSTRUCTION LOG

PROJECT NUMBER 56111-6169.001.TK5.MOBIL BORING/WELL NUMBER CDM-CB-7
PROJECT NAME Aerojet - GEDIT DATE DRILLED 9/2/08

Continued from Previous Page

PID (ppm)	BLOW COUNTS	RECOVERY (inches)	SAMPLE ID.	EXTENT	DEPTH (ft. bgs)	U.S.C.S.	GRAPHIC LOG	LITHOLOGIC DESCRIPTION	CONTACT DEPTH	WELL DIAGRAM
NM		50				CL		GRAVELLY CLAY: moderate brown (5YR 3/4); 80% clay, soft, high plasticity; 20% gravel, well graded, fine to coarse grained, maximum diameter of 3 inches, subrounded to subangular; dry, no odor.	38.0	
NM					40			SILTY GRAVEL: moderate brown (5YR 4/4); 75% gravel, well graded, fine and coarse grained, maximum diameter of 3 inches, subrounded to subangular; 25% silt, soft, moderate plasticity; dry, no odor.		
NM					45	GM				
NM					50			Total depth of borehole was 50.0 feet below ground surface.	50.0	
					55					
					60					
					65					
					70					
					75					

NEWGINT_SAC_AEROJET_120908.GPJ NEWGINT.GDT 11/13/09



2295 Gateway Oaks
Suite 240
Sacramento, CA 95833
(916) 567-9900

BORING/WELL CONSTRUCTION LOG

PROJECT NUMBER 56111-6169.001.TK5.MOBIL BORING/WELL NUMBER CDM-CB-8
 PROJECT NAME Aerojet - GEDIT DATE DRILLED 9/2/08
 LOCATION Rancho Cordova, CA CASING TYPE/DIAMETER NA
 DRILLING METHOD Sonic SCREEN TYPE/SLOT NA
 SAMPLING METHOD Continuous Core GRAVEL PACK TYPE NA
 GROUND SURFACE ELEVATION (FT MSL) NA GROUT TYPE/QUANTITY Bentonite Grout
 TOP OF CASING ELEVATION (FT MSL) NA STATIC WATER LEVEL (FT BELOW TOC) NA
 LOGGED BY K. Hopfensperger GROUND WATER ELEVATION (FT MSL) _____
 REMARKS _____

PID (ppm)	BLOW COUNTS	RECOVERY (inches)	SAMPLE ID.	EXTENT	DEPTH (ft. bgs)	U.S.C.S.	GRAPHIC LOG	LITHOLOGIC DESCRIPTION	CONTACT DEPTH	WELL DIAGRAM
						ML		SILT: light brown (5YR 5/6); 100% silt, low plasticity to non-plastic; dry, no odor.	2.0	No well constructed. Borehole abandoned with bentonite grout.
NM		100			5	CL		CLAY: moderate brown (5YR 4/4); 100% clay, soft, moderate to high plasticity; dry, no odor.		
NM		100			10					
NM		100			15	GC		CLAYEY GRAVEL: moderate brown (5YR 4/4); 60% gravel, well graded, fine to coarse grained, maximum diameter of 3 inches, subangular to subrounded; 40% clay, soft, moderate to high plasticity; dry, no odor.	13.0	
NM		50			20					
					25				22.0	
NM		50			25			GRAVEL WITH SAND: dark yellowish orange (10YR 6/6); 70% gravel, well graded, fine to coarse grained, maximum diameter of 2.5 inches, subrounded; 30% sand, poorly graded, fine grained, subrounded; dry, no odor.		
NM		50			30	GW				
					35					

Continued Next Page



2295 Gateway Oaks
Suite 240
Sacramento, CA 95833
(916) 567-9900

BORING/WELL CONSTRUCTION LOG

PROJECT NUMBER 56111-6169.001.TK5.MOBIL BORING/WELL NUMBER CDM-CB-8
PROJECT NAME Aerojet - GEDIT DATE DRILLED 9/2/08

Continued from Previous Page

PID (ppm)	BLOW COUNTS	RECOVERY (inches)	SAMPLE ID.	EXTENT	DEPTH (ft. bgs)	U.S.C.S.	GRAPHIC LOG	LITHOLOGIC DESCRIPTION	CONTACT DEPTH	WELL DIAGRAM
NM		50								
NM		70			40			SILTY GRAVEL: dusky yellow (5Y 6/4); 70% gravel, well graded, medium to coarse grained, maximum diameter of 1.5 inches, subrounded to subangular; 30% silt, non-plastic: dry, no odor.	37.0	
NM		70		45						
NM		70		50						
NM		70		50						
					55			Total depth of borehole was 50.0 feet below ground surface.	50.0	
					60					
					65					
					70					
					75					

NEWGINT_SAC_AEROJET_120908.GPJ_NEWGINT.GDT 11/13/09



2295 Gateway Oaks
Suite 240
Sacramento, CA 95833
(916) 567-9900

BORING/WELL CONSTRUCTION LOG

PROJECT NUMBER 56111-6169.001.TK5.MOBIL BORING/WELL NUMBER CDM-CB-9
 PROJECT NAME Aerojet - GEDIT DATE DRILLED 12/2/08
 LOCATION Rancho Cordova, CA CASING TYPE/DIAMETER NA
 DRILLING METHOD Sonic SCREEN TYPE/SLOT NA
 SAMPLING METHOD Continuous Core GRAVEL PACK TYPE NA
 GROUND SURFACE ELEVATION (FT MSL) NA GROUT TYPE/QUANTITY Bentonite Grout
 TOP OF CASING ELEVATION (FT MSL) NA STATIC WATER LEVEL (FT BELOW TOC) NA
 LOGGED BY K. Hopfensperger GROUND WATER ELEVATION (FT MSL) _____
 REMARKS _____

PID (ppm)	BLOW COUNTS	RECOVERY (inches)	SAMPLE ID.	EXTENT	DEPTH (ft. bgs)	U.S.C.S.	GRAPHIC LOG	LITHOLOGIC DESCRIPTION	CONTACT DEPTH	WELL DIAGRAM
NM		50			5	ML		SILT: moderate brown (5YR 4/4); 100% silt, soft, non-plastic; dry, no odor.	7.0	No well constructed. Borehole abandoned with bentonite grout.
NM		100			10	GW		GRAVEL WITH SAND: moderate yellowish brown (10YR 5/4); 60% gravel, well graded, fine to coarse grained, maximum diameter of 2 inches; 40% sand, well graded, fine to coarse grained, subrounded to subangular; dry, no odor.	12.0	
NM		100			15	GW		GRAVEL WITH SAND: moderate yellowish brown (10YR 5/4); 50% gravel, well graded, fine to coarse grained, maximum diameter of 2 inches; 50% sand, well graded, fine to coarse grained, subrounded to subangular; dry, no odor.	16.0	
NM		100			20	CL		GRAVELLY CLAY: moderate brown (5YR 4/4); 70% clay, silty, low plasticity; 30% gravel, moderately well graded, medium to coarse grained, maximum diameter of 3 inches, rounded to subrounded; dry, no odor.	27.0	
NM		100			25	CL		GRAVELLY CLAY: moderate brown (5YR 4/4); 60% clay, silty, low plasticity; 40% gravel, moderately well graded, medium to coarse grained, maximum diameter of 3 inches, rounded to subrounded; dry, no odor.	32.0	
NM		100			30	CL		SILTY GRAVEL: moderate brown (5YR 4/4); 70% gravel, well graded, fine to coarse grained, maximum diameter of 2 inches, subrounded to subangular; 30% silt, soft; dry, no odor.		
					35					

Continued Next Page



2295 Gateway Oaks
Suite 240
Sacramento, CA 95833
(916) 567-9900

BORING/WELL CONSTRUCTION LOG

PROJECT NUMBER 56111-6169.001.TK5.MOBIL BORING/WELL NUMBER CDM-CB-9
PROJECT NAME Aerojet - GEDIT DATE DRILLED 12/2/08

Continued from Previous Page

PID (ppm)	BLOW COUNTS	RECOVERY (inches)	SAMPLE ID.	EXTENT	DEPTH (ft. bgs)	U.S.C.S.	GRAPHIC LOG	LITHOLOGIC DESCRIPTION	CONTACT DEPTH	WELL DIAGRAM
NM		100								
NM		50			40	GM				
NM		100			45	SW		SAND WITH GRAVEL: moderate brown (5YR 4/4); 80% sand, moderately well graded, fine to medium grained, subrounded to subangular; 20% gravel, well graded, maximum diameter of 1 inch, subangular; dry, no odor.	43.0	
NM		100			50			Total depth of borehole was 50.0 feet below ground surface.	50.0	
					55					
					60					
					65					
					70					
					75					

NEWGINT_SAC_AEROJET_120908.GPJ_NEWGINT.GDT 11/13/09



2295 Gateway Oaks
Suite 240
Sacramento, CA 95833
(916) 567-9900

BORING/WELL CONSTRUCTION LOG

PROJECT NUMBER 56111-6169.001.TK5.MOBIL **BORING/WELL NUMBER** CDM-CB-10
PROJECT NAME Aerojet - GEDIT **DATE DRILLED** 12/2/08
LOCATION Rancho Cordova, CA **CASING TYPE/DIAMETER** NA
DRILLING METHOD Sonic **SCREEN TYPE/SLOT** NA
SAMPLING METHOD Continuous Core **GRAVEL PACK TYPE** NA
GROUND SURFACE ELEVATION (FT MSL) NA **GROUT TYPE/QUANTITY** Bentonite Grout
TOP OF CASING ELEVATION (FT MSL) NA **STATIC WATER LEVEL (FT BELOW TOC)** NA
LOGGED BY K. Hopfensperger **GROUND WATER ELEVATION (FT MSL)** _____
REMARKS _____

PID (ppm)	BLOW COUNTS	RECOVERY (inches)	SAMPLE ID.	EXTENT	DEPTH (ft. bgs)	U.S.C.S.	GRAPHIC LOG	LITHOLOGIC DESCRIPTION	CONTACT DEPTH	WELL DIAGRAM
						SP		SAND: dark yellowish orange (10YR 6/6); 100% sand, poorly graded, fine grained, subangular; dry, no odor.	2.0	No well constructed. Borehole abandoned with bentonite grout.
NM	100				5	GM		SILTY GRAVEL: light brown (5YR 5/6); 60% gravel, well graded, fine to coarse grained, maximum diameter of 2 inches; 40% silt, soft, non-plastic; dry, no odor.		
NM	100				10	GW		GRAVEL WITH SAND: moderate brown (5YR 4/4); 70% gravel, well graded, fine to coarse grained, maximum diameter of 3 inches, subrounded to subangular; 30% sand, well graded, fine to medium grained, subrounded to subangular; dry, no odor.	8.0	
NM	100				15					
NM	100				20	CL		CLAY WITH GRAVEL: moderate brown (5YR 4/4); 75% clay, soft, low plasticity; 25% gravel, poorly graded, coarse grained, maximum diameter of 1 inch, subrounded to subangular; moist, no odor.	16.0	
NM	100				25					
NM	100				30	GM		SILTY GRAVEL: 60% gravel, poorly graded, coarse grained, maximum diameter of 1 inch, subrounded to subangular; 40% silt, soft, non-plastic; slightly moist, no odor.	29.0	
					35				35.0	

Continued Next Page

NEWGINT_SAC_AEROJET_120908.GPJ NEWGINT.GDT 11/13/09



2295 Gateway Oaks
Suite 240
Sacramento, CA 95833
(916) 567-9900

BORING/WELL CONSTRUCTION LOG

PROJECT NUMBER 56111-6169.001.TK5.MOBIL BORING/WELL NUMBER CDM-CB-10
PROJECT NAME Aerojet - GEDIT DATE DRILLED 12/2/08

Continued from Previous Page

PID (ppm)	BLOW COUNTS	RECOVERY (inches)	SAMPLE ID.	EXTENT	DEPTH (ft. bgs)	U.S.C.S.	GRAPHIC LOG	LITHOLOGIC DESCRIPTION	CONTACT DEPTH	WELL DIAGRAM
NM		100				GW		GRAVEL WITH SAND: moderate brown (5YR 4/4); 50% gravel, well graded, medium to coarse grained, maximum diameter of 2 inches, subrounded to subangular; 50% sand, well graded, fine to coarse grained, subangular; dry, no odor.		
NM		50			40	GM		SILTY GRAVEL: moderate brown (5YR 4/4); 70% gravel, well graded, medium to coarse grained, maximum diameter of 2 inches, subrounded to subangular; 30% silt, soft; slightly moist, no odor.	40.0	
NM		100			45	GW		GRAVEL WITH SAND: 70% gravel, well graded, fine to coarse grained, maximum diameter of 3 inches, subangular to subrounded; 30% sand, well graded, fine to coarse grained, subrounded to subangular; dry, no odor.	43.0	
NM		100			50			Total depth of borehole was 50.0 feet below ground surface.	50.0	
					55					
					60					
					65					
					70					
					75					



2295 Gateway Oaks
Suite 240
Sacramento, CA 95833
(916) 567-9900

BORING/WELL CONSTRUCTION LOG

PROJECT NUMBER 56111-6169.001.TK5.MOBIL BORING/WELL NUMBER CDM-CB-11
 PROJECT NAME Aerojet - GEDIT DATE DRILLED 12/3/08
 LOCATION Rancho Cordova, CA CASING TYPE/DIAMETER NA
 DRILLING METHOD Sonic SCREEN TYPE/SLOT NA
 SAMPLING METHOD Continuous Core GRAVEL PACK TYPE NA
 GROUND SURFACE ELEVATION (FT MSL) NA GROUT TYPE/QUANTITY Bentonite Grout
 TOP OF CASING ELEVATION (FT MSL) NA STATIC WATER LEVEL (FT BELOW TOC) NA
 LOGGED BY K. Hopfensperger GROUND WATER ELEVATION (FT MSL) _____
 REMARKS _____

PID (ppm)	BLOW COUNTS	RECOVERY (inches)	SAMPLE ID.	EXTENT	DEPTH (ft. bgs)	U.S.C.S.	GRAPHIC LOG	LITHOLOGIC DESCRIPTION	CONTACT DEPTH	WELL DIAGRAM
						ML		SILT: dark yellowish orange (10 YR 6/6); 100% silt, soft, low plasticity; dry, no odor.	2.0	No well constructed. Borehole abandoned with bentonite grout.
						CL		CLAY: moderate yellowish brown (10 YR 5/4); 100% clay, soft, moderate plasticity, dry, no odor.	3.0	
NM		100			5	GW		GRAVEL WITH SAND: light brown (5YR 4/4); 70% gravel, well graded, fine to coarse grained, maximum diameter of 3 inches, subrounded to subangular; 30% sand, well graded, fine to medium grained, subrounded to subangular; dry, no odor.		
NM		100			10			SILTY GRAVEL: light brown (5YR 5/6); 60% gravel, well graded, fine to coarse grained, maximum diameter of 3 inches, subrounded to subangular; 40% silt, soft, low plasticity; slightly moist, no odor.	10.0	
NM		100			15	GM				
NM		50			20					
NM		100			25	GC		CLAYEY GRAVEL: moderate yellowish brown (10YR 5/4); 50% gravel, well graded, medium to coarse grained, maximum diameter of 2 inches, subrounded; 50% clay, silty, low plasticity; dry, no odor.	22.0	
NM		100			30					
					35			GRAVELLY SILT: moderate yellowish brown (10YR 5/4); 70% silt, soft, low plasticity; 30% gravel, well graded, medium to coarse grained, maximum diameter of 3	33.0	

Continued Next Page

NEWGINT_SAC_AEROJET_120908.GPJ_NEWGINT.GDT 11/13/09



2295 Gateway Oaks
Suite 240
Sacramento, CA 95833
(916) 567-9900

BORING/WELL CONSTRUCTION LOG

PROJECT NUMBER 56111-6169.001.TK5.MOBIL

BORING/WELL NUMBER CDM-CB-11

PROJECT NAME Aerojet - GEDIT

DATE DRILLED 12/3/08

Continued from Previous Page

PID (ppm)	BLOW COUNTS	RECOVERY (inches)	SAMPLE ID.	EXTENT	DEPTH (ft. bgs)	U.S.C.S.	GRAPHIC LOG	LITHOLOGIC DESCRIPTION	CONTACT DEPTH	WELL DIAGRAM
NM		100				ML		inches, subrounded; dry, no odor.		
NM		100			40	ML		SILT WITH GRAVEL: moderate yellowish brown (10YR 5/4); 80% silt, soft, non-plastic; 20% gravel, well graded, fine to coarse grained, maximum diameter of 1 inch, subrounded; dry, no odor.	39.0 41.0	
						SW		SAND WITH GRAVEL: moderate brown (5YR 4/4); 60% sand, well graded, medium to coarse grained, subrounded; 40% gravel, poorly graded, coarse grained, maximum diameter of 0.5 inches; dry, no odor.	44.0	
NM		100			45	ML		SILT: moderate brown (5YR 4/4); 90% silt, soft, non-plastic; 10% gravel, poorly graded, coarse grained, maximum diameter of 0.5 inches; dry, no odor.	46.0	
						GW		GRAVEL WITH SAND: pale yellowish brown (10YR 6/2); 70% gravel, well graded, fine to coarse grained, maximum diameter of 1.5 inches, subrounded to subangular; 30% sand, well graded, fine to coarse grained, subangular to angular; dry, no odor.	50.0	
NM		100			50			Total depth of borehole was 50.0 feet below ground surface.		
					55					
					60					
					65					
					70					
					75					



2295 Gateway Oaks
Suite 240
Sacramento, CA 95833
(916) 567-9900

BORING/WELL CONSTRUCTION LOG

PROJECT NUMBER 56111-6169.001.TK5.MOBIL BORING/WELL NUMBER CDM-CB-12
 PROJECT NAME Aerojet - GEDIT DATE DRILLED 12/3/08
 LOCATION Rancho Cordova, CA CASING TYPE/DIAMETER NA
 DRILLING METHOD Sonic SCREEN TYPE/SLOT NA
 SAMPLING METHOD Continuous Core GRAVEL PACK TYPE NA
 GROUND SURFACE ELEVATION (FT MSL) NA GROUT TYPE/QUANTITY Bentonite Grout
 TOP OF CASING ELEVATION (FT MSL) NA STATIC WATER LEVEL (FT BELOW TOC) NA
 LOGGED BY K. Hopfensperger GROUND WATER ELEVATION (FT MSL) _____
 REMARKS _____

PID (ppm)	BLOW COUNTS	RECOVERY (inches)	SAMPLE ID.	EXTENT	DEPTH (ft. bgs)	U.S.C.S.	GRAPHIC LOG	LITHOLOGIC DESCRIPTION	CONTACT DEPTH	WELL DIAGRAM
						ML		SILT: dark yellowish orange (10YR 6/6); 100% silt, soft, non-plastic; dry, no odor.	2.0	No well constructed. Borehole abandoned with bentonite grout.
NM		100			5	CL		CLAY: light brown (5YR 5/6); 100% clay, soft, low to moderate plasticity; dry, no odor.		
NM		100			10					
NM		100			15	GW		GRAVEL WITH SAND: dark yellowish orange (10YR 6/6); 70% gravel, well graded, medium to coarse grained, maximum diameter of 3 inches, subangular; 30% sand, well graded, fine to medium grained, subangular; dry, no odor.	13.0	
NM		50			20	GM		SILTY GRAVEL: moderate brown (5YR 4/4); 70% gravel, well graded, medium to coarse grained, maximum diameter of 1.5 inches, subrounded to subangular; 30% silt, soft, low plasticity; dry, no odor.	18.0	
NM		100			25					
NM		100			30	GW		GRAVEL WITH SAND: pale yellowish brown (10 YR 6/2); 70% gravel, well graded, fine to coarse grained, maximum diameter of 3 inches, subangular; 30% sand, well graded, fine to coarse grained, subangular; dry, no odor.	27.0	
					35			GRAVEL WITH SAND: pale yellowish brown (10 YR 6/2);	34.0	

Continued Next Page



2295 Gateway Oaks
Suite 240
Sacramento, CA 95833
(916) 567-9900

BORING/WELL CONSTRUCTION LOG

PROJECT NUMBER 56111-6169.001.TK5.MOBIL BORING/WELL NUMBER CDM-CB-12
PROJECT NAME Aerojet - GEDIT DATE DRILLED 12/3/08

Continued from Previous Page

PID (ppm)	BLOW COUNTS	RECOVERY (inches)	SAMPLE ID.	EXTENT	DEPTH (ft. bgs)	U.S.C.S.	GRAPHIC LOG	LITHOLOGIC DESCRIPTION	CONTACT DEPTH	WELL DIAGRAM
NM		100				GW		50% gravel, well graded, fine to coarse grained, maximum diameter of 3 inches, subangular; 50% sand, well graded, fine to coarse grained, subangular; dry, no odor.		
NM		100			40	GM		SILTY GRAVEL: light brown (5YR 5/6); 65% gravel, well graded, fine to coarse grained, maximum diameter of 2 inches, subrounded to subangular; 35% silt, soft, low plasticity; dry, no odor.	40.0	
NM		100			45	GW		GRAVEL WITH SAND: pale yellowish brown (10 YR 6/2); 50% gravel, well graded, fine to coarse grained, maximum diameter of 2 inches, subrounded to subangular; 50% sand, poorly graded, fine to medium grained, subangular; dry, no odor.	45.0	
NM		100			50			Total depth of borehole was 50.0 feet below ground surface.	50.0	
					55					
					60					
					65					
					70					
					75					

NEWGINT_SAC_AEROJET_120908.GPJ NEWGINT.GDT 11/13/09



2295 Gateway Oaks
Suite 240
Sacramento, CA 95833
(916) 567-9900

BORING/WELL CONSTRUCTION LOG

PROJECT NUMBER 56111-6169.001.TK5.MOBIL BORING/WELL NUMBER CDM-CB-13
 PROJECT NAME Aerojet - GEDIT DATE DRILLED 12/3/08
 LOCATION Rancho Cordova, CA CASING TYPE/DIAMETER NA
 DRILLING METHOD Sonic SCREEN TYPE/SLOT NA
 SAMPLING METHOD Continuous Core GRAVEL PACK TYPE NA
 GROUND SURFACE ELEVATION (FT MSL) NA GROUT TYPE/QUANTITY Bentonite Grout
 TOP OF CASING ELEVATION (FT MSL) NA STATIC WATER LEVEL (FT BELOW TOC) NA
 LOGGED BY K. Hopfensperger GROUND WATER ELEVATION (FT MSL) _____
 REMARKS _____

PID (ppm)	BLOW COUNTS	RECOVERY (inches)	SAMPLE ID.	EXTENT	DEPTH (ft. bgs)	U.S.C.S.	GRAPHIC LOG	LITHOLOGIC DESCRIPTION	CONTACT DEPTH	WELL DIAGRAM
						ML		SILT: light brown (5YR 5/6); 100% silt, soft, non-plastic; dry, no odor.	2.0	No well constructed. Borehole abandoned with bentonite grout.
NM		100			5	CL		CLAY: light brown (5YR 5/6); 100% clay, soft, high plasticity; dry, no odor.		
NM		100			10					
						GW		GRAVEL WITH SAND: 75% gravel, well graded, fine to coarse grained, maximum diameter of 1.5 inches, subangular; 25% sand, poorly graded, fine grained, subangular; dry, no odor.	12.0	
NM		100			15	ML		SILT: light brown (5YR 5/6); 100% silt, soft, moderate plasticity; dry, no odor.	15.0	
NM		50			20			SILTY GRAVEL: moderate brown (5YR 4/4); 70% gravel, well graded, fine to coarse grained, maximum diameter of 3 inches, subrounded to subangular; 30% silt, soft, non-plastic; dry, no odor.	18.0	
NM		50			25	GM				
NM		50			30					
					35			GRAVEL WITH SAND: dark yellowish orange (10YR 6/6); 65% gravel, well graded, fine to coarse grained, maximum diameter of 3 inches, subangular to angular; 35% sand,	33.0	

Continued Next Page

NEWGINT_SAC_AEROJET_120908.GPJ_NEWGINT.GDT 11/13/09



2295 Gateway Oaks
Suite 240
Sacramento, CA 95833
(916) 567-9900

BORING/WELL CONSTRUCTION LOG

PROJECT NUMBER 56111-6169.001.TK5.MOBIL BORING/WELL NUMBER CDM-CB-13
PROJECT NAME Aerojet - GEDIT DATE DRILLED 12/3/08

Continued from Previous Page

PID (ppm)	BLOW COUNTS	RECOVERY (inches)	SAMPLE ID.	EXTENT	DEPTH (ft. bgs)	U.S.C.S.	GRAPHIC LOG	LITHOLOGIC DESCRIPTION	CONTACT DEPTH	WELL DIAGRAM
NM		50				GW		well graded, fine to coarse grained, subangular; dry, no odor.	37.0	
NM		100			40	GM		SILTY GRAVEL: light brown (5YR 5/6); 70% gravel, well graded, fine to coarse grained, maximum diameter of 2 inches, subrounded; 30% silt, soft, moderate plasticity; dry, no odor.		
NM		100			45	GW		GRAVEL WITH SAND: pale yellowish brown (10YR 6/2); 60% gravel, well graded, fine to coarse grained, maximum diameter of 3 inches, subrounded; 40% sand, well graded, fine to coarse grained, subrounded to subangular; dry, no odor.	45.0	
NM		100			50			Total depth of borehole was 50.0 feet below ground surface.	50.0	
					55					
					60					
					65					
					70					
					75					

NEWGINT_SAC_AEROJET_120908.GPJ NEWGINT.GDT 11/13/09



2295 Gateway Oaks
Suite 240
Sacramento, CA 95833
(916) 567-9900

BORING/WELL CONSTRUCTION LOG

PROJECT NUMBER 56111-6169.001.TK5.MOBIL **BORING/WELL NUMBER** CDM-CB-14
PROJECT NAME Aerojet - GEDIT **DATE DRILLED** 12/3/08
LOCATION Rancho Cordova, CA **CASING TYPE/DIAMETER** NA
DRILLING METHOD Sonic **SCREEN TYPE/SLOT** NA
SAMPLING METHOD Continuous Core **GRAVEL PACK TYPE** NA
GROUND SURFACE ELEVATION (FT MSL) NA **GROUT TYPE/QUANTITY** Bentonite Grout
TOP OF CASING ELEVATION (FT MSL) NA **STATIC WATER LEVEL (FT BELOW TOC)** NA
LOGGED BY K. Hopfensperger **GROUND WATER ELEVATION (FT MSL)** _____
REMARKS _____

PID (ppm)	BLOW COUNTS	RECOVERY (inches)	SAMPLE ID.	EXTENT	DEPTH (ft. bgs)	U.S.C.S.	GRAPHIC LOG	LITHOLOGIC DESCRIPTION	CONTACT DEPTH	WELL DIAGRAM
NM	100				5	CL		CLAY: light brown (5YR 5/6); 100% clay, soft, moderate plasticity; dry, no odor.		No well constructed. Borehole abandoned with bentonite grout.
NM	100				10					
NM	100				15	ML		SILT: light brown (5YR 5/6); 100% silt, soft, low plasticity; dry, no odor.	13.0	
NM	100				20	CL		CLAY: light brown (5YR 5/6); 100% clay, soft, moderate plasticity; dry, no odor.	16.0	
NM	100				25				25.0	
NM	100				30	GM		SILTY GRAVEL WITH SAND: moderate brown (5YR 4/4); 60% gravel, well graded, fine to coarse grained, maximum diameter of 3 inches, subrounded to subangular; 20% sand, well graded, fine to coarse grained, subangular; 20% silt, soft, low plasticity; dry, no odor.	25.0	
					35				35.0	

Continued Next Page

NEWGINT_SAC_AEROJET_120908.GPJ NEWGINT.GDT 11/13/09





2295 Gateway Oaks
 Suite 240
 Sacramento, CA 95833
 (916) 567-9900

BORING/WELL CONSTRUCTION LOG

PROJECT NUMBER 56111-6169.001.TK5.MOBIL BORING/WELL NUMBER CDM-CB-14
 PROJECT NAME Aerojet - GEDIT DATE DRILLED 12/3/08

Continued from Previous Page

PID (ppm)	BLOW COUNTS	RECOVERY (inches)	SAMPLE ID.	EXTENT	DEPTH (ft. bgs)	U.S.C.S.	GRAPHIC LOG	LITHOLOGIC DESCRIPTION	CONTACT DEPTH	WELL DIAGRAM
NM		100				CL		CLAY: light brown (5YR 5/6); 100% clay, soft, moderate plasticity; dry, no odor.	37.0	
NM		100			40			SILTY GRAVEL WITH SAND: light brown (5YR 5/6); 50% gravel, well graded, fine to coarse grained, maximum diameter of 2 inches; 25% sand, well graded, fine to coarse grained, subangular; 25% silt, soft, low plasticity; dry, no odor.		
NM		100			45	GM				
NM		100			50			Total depth of borehole was 50.0 feet below ground surface.	50.0	
					55					
					60					
					65					
					70					
					75					



NEWGINT_SAC_AEROJET_120908.GPJ_NEWGINT.GDT 11/13/09



2295 Gateway Oaks
Suite 240
Sacramento, CA 95833
(916) 567-9900

BORING/WELL CONSTRUCTION LOG

PROJECT NUMBER 56111-6169.001.TK5.MOBIL BORING/WELL NUMBER CDM-CB-15
 PROJECT NAME Aerojet - GEDIT DATE DRILLED 12/3/08
 LOCATION Rancho Cordova, CA CASING TYPE/DIAMETER NA
 DRILLING METHOD Sonic SCREEN TYPE/SLOT NA
 SAMPLING METHOD Continuous Core GRAVEL PACK TYPE NA
 GROUND SURFACE ELEVATION (FT MSL) NA GROUT TYPE/QUANTITY Bentonite Grout
 TOP OF CASING ELEVATION (FT MSL) NA STATIC WATER LEVEL (FT BELOW TOC) NA
 LOGGED BY K. Hopfensperger GROUND WATER ELEVATION (FT MSL) _____
 REMARKS _____

PID (ppm)	BLOW COUNTS	RECOVERY (inches)	SAMPLE ID.	EXTENT	DEPTH (ft. bgs)	U.S.C.S.	GRAPHIC LOG	LITHOLOGIC DESCRIPTION	CONTACT DEPTH	WELL DIAGRAM
						ML		SILT: light brown (5YR 5/6); 100% silt, soft, non-plastic; dry, no odor.	2.0	No well constructed. Borehole abandoned with bentonite grout.
NM		100			5			CLAY: light brown (5YR 5/6); 100% clay, soft, high plasticity; dry, no odor.		
NM		100			10					
NM		100			15	CL				
NM		50			20					
NM		100			25			GRAVEL WITH SAND: light brown (5YR 5/6), 50% gravel, well graded, fine to coarse grained, maximum diameter of 3 inches, subrounded to subangular; 50% sand, well graded, fine to medium grained, subangular; dry, no odor.	24.0	
NM		100			30	GW				
					35				35.0	

Continued Next Page



2295 Gateway Oaks
Suite 240
Sacramento, CA 95833
(916) 567-9900

BORING/WELL CONSTRUCTION LOG

PROJECT NUMBER 56111-6169.001.TK5.MOBIL BORING/WELL NUMBER CDM-CB-15
PROJECT NAME Aerojet - GEDIT DATE DRILLED 12/3/08

Continued from Previous Page

PID (ppm)	BLOW COUNTS	RECOVERY (inches)	SAMPLE ID.	EXTENT	DEPTH (ft. bgs)	U.S.C.S.	GRAPHIC LOG	LITHOLOGIC DESCRIPTION	CONTACT DEPTH	WELL DIAGRAM
NM		100						CLAYEY GRAVEL: moderate brown (5YR 4/4); 60% gravel, well graded, fine to coarse grained, maximum diameter of 1 inch, subrounded to subangular; 40% clay, soft, low to moderate plasticity; dry, no odor.		
NM		100			40	GC				
NM		100			45				46.0	
						GW		GRAVEL WITH SAND: pale yellowish orange (10YR 6/2); 50% gravel, well graded, fine to coarse grained, maximum diameter of 3 inches, subangular to angular; 50% sand, well graded, fine to coarse grained, subangular; dry, no odor.		
NM		100			50			Total depth of borehole was 50.0 feet below ground surface.	50.0	
					55					
					60					
					65					
					70					
					75					

NEWGINT_SAC_AEROJET_120908.GPJ NEWGINT.GDT 11/13/09



2295 Gateway Oaks
Suite 240
Sacramento, CA 95833
(916) 567-9900

BORING/WELL CONSTRUCTION LOG

PROJECT NUMBER 56111-6169.001.TK5.MOBIL BORING/WELL NUMBER CDM-CB-16
 PROJECT NAME Aerojet - GEDIT DATE DRILLED 12/3/08
 LOCATION Rancho Cordova, CA CASING TYPE/DIAMETER NA
 DRILLING METHOD Sonic SCREEN TYPE/SLOT NA
 SAMPLING METHOD Continuous Core GRAVEL PACK TYPE NA
 GROUND SURFACE ELEVATION (FT MSL) NA GROUT TYPE/QUANTITY Bentonite Grout
 TOP OF CASING ELEVATION (FT MSL) NA STATIC WATER LEVEL (FT BELOW TOC) NA
 LOGGED BY K. Hopfensperger GROUND WATER ELEVATION (FT MSL) _____
 REMARKS _____

PID (ppm)	BLOW COUNTS	RECOVERY (inches)	SAMPLE ID.	EXTENT	DEPTH (ft. bgs)	U.S.C.S.	GRAPHIC LOG	LITHOLOGIC DESCRIPTION	CONTACT DEPTH	WELL DIAGRAM
						ML		SILT: light brown (5YR 5/6); 100% silt, soft, low plasticity; dry, no odor.	3.0	No well constructed. Borehole abandoned with bentonite grout.
NM		100			5			CLAY: light brown (5YR 5/6); 100% clay, soft, moderate to high plasticity; dry, no odor.		
NM		100			10	CL				
NM		100			15					
NM		100			16.0	CL		CLAY WITH GRAVEL: light brown (5YR 5/6); 80% clay, soft, moderate to high plasticity; 20% gravel, poorly graded, fine to medium graded, maximum diameter of 0.5 inches, subangular; dry, no odor.	16.0	
NM		100			18.0			CLAY: light brown (5YR 5/6); 100% clay, soft, moderate to high plasticity; dry, no odor.	18.0	
NM		100			20					
NM		100			25	CL				
NM		100			30			GRAVEL WITH SAND: light brown (5YR 5/6); 50% gravel, well graded, fine to coarse graded, maximum diameter of 2 inches, subrounded; 50% sand, well graded, fine to coarse graded, subangular; dry, no odor.	30.0	
					35	GW			35.0	

Continued Next Page





2295 Gateway Oaks
Suite 240
Sacramento, CA 95833
(916) 567-9900

BORING/WELL CONSTRUCTION LOG

PROJECT NUMBER 56111-6169.001.TK5.MOBIL BORING/WELL NUMBER CDM-CB-16
PROJECT NAME Aerojet - GEDIT DATE DRILLED 12/3/08

Continued from Previous Page

PID (ppm)	BLOW COUNTS	RECOVERY (inches)	SAMPLE ID.	EXTENT	DEPTH (ft. bgs)	U.S.C.S.	GRAPHIC LOG	LITHOLOGIC DESCRIPTION	CONTACT DEPTH	WELL DIAGRAM
NM		100				CL		CLAY: light brown (5YR 5/6); 100% clay, soft, moderate to high plasticity; dry, no odor.	36.0	
NM		100			40			SILTY GRAVEL WITH SAND: pale yellowish brown (10YR 6/2); 50% gravel, well graded, fine to coarse grained, maximum diameter of 2 inches, subrounded to subangular; 25% sand, well graded, fine to coarse grained, subrounded to subangular; 25% silt, soft, low plasticity; dry, slight odor of propane.		
NM		100			45	GM				
NM		100			50			Total depth of borehole was 50.0 feet below ground surface.	50.0	
					55					
					60					
					65					
					70					
					75					

NEWGINT_SAC_AEROJET_120908.GPJ_NEWGINT.GDT 11/13/09



2295 Gateway Oaks
Suite 240
Sacramento, CA 95833
(916) 567-9900

BORING/WELL CONSTRUCTION LOG

PROJECT NUMBER 56111-6169.001.TK5.MOBIL BORING/WELL NUMBER CDM-CB-17
 PROJECT NAME Aerojet - GEDIT DATE DRILLED 12/3/08
 LOCATION Rancho Cordova, CA CASING TYPE/DIAMETER NA
 DRILLING METHOD Sonic SCREEN TYPE/SLOT NA
 SAMPLING METHOD Continuous Core GRAVEL PACK TYPE NA
 GROUND SURFACE ELEVATION (FT MSL) NA GROUT TYPE/QUANTITY Bentonite Grout
 TOP OF CASING ELEVATION (FT MSL) NA STATIC WATER LEVEL (FT BELOW TOC) NA
 LOGGED BY K. Hopfensperger GROUND WATER ELEVATION (FT MSL) _____
 REMARKS _____

PID (ppm)	BLOW COUNTS	RECOVERY (inches)	SAMPLE ID.	EXTENT	DEPTH (ft. bgs)	U.S.C.S.	GRAPHIC LOG	LITHOLOGIC DESCRIPTION	CONTACT DEPTH	WELL DIAGRAM
						CL		CLAY: moderate brown (5YR 4/4); 100% clay, soft, moderate plasticity; dry, no odor.	3.0	No well constructed. Borehole abandoned with bentonite grout.
NM	100				5			CLAY: light brown (5YR 5/6); 100% clay, soft, high plasticity; dry, no odor.		
NM	100				10	CL				
NM	100				15			CLAY: light brown (5YR 5/6); 90% clay, soft, high plasticity; 10% silt, soft, low to moderate plasticity; dry, no odor.	15.0	
NM	100				20	CL				
NM	100				25					
NM	100				30	GM		SILTY GRAVEL; light brown (5YR 5/6); 60% gravel, well graded, fine to coarse grained, maximum diameter of 3 inches, subrounded; 40% silt, soft, low to moderate plasticity; dry, no odor.	28.0	
									32.0	
						GW		GRAVEL WITH SAND: pale yellowish brown (10YR 6/2); 75% gravel, well graded, fine to coarse grained, maximum diameter of 3 inches, subrounded; 25% sand, well graded, fine to coarse grained, subangular; dry, no odor.	35.0	

Continued Next Page

NEWGINT_SAC_AEROJET_120908.GPJ NEWGINT.GDT 11/13/09





2295 Gateway Oaks
Suite 240
Sacramento, CA 95833
(916) 567-9900

BORING/WELL CONSTRUCTION LOG

PROJECT NUMBER 56111-6169.001.TK5.MOBIL BORING/WELL NUMBER CDM-CB-17
PROJECT NAME Aerojet - GEDIT DATE DRILLED 12/3/08

Continued from Previous Page

PID (ppm)	BLOW COUNTS	RECOVERY (inches)	SAMPLE ID.	EXTENT	DEPTH (ft. bgs)	U.S.C.S.	GRAPHIC LOG	LITHOLOGIC DESCRIPTION	CONTACT DEPTH	WELL DIAGRAM
NM		100								
NM		50			40	CL		CLAY WITH GRAVEL: moderate brown (5YR 4/4); 60% clay, soft, moderate to high plasticity; 30% gravel, well graded, fine to coarse grained, maximum diameter of 2 inches, subrounded to subangular; 10% silt, soft, low to moderate plasticity; dry, no odor.		
NM		100			45	GW		GRAVEL WITH SAND: light brown (5YR 5/6); 60% gravel, well graded, fine to coarse grained, maximum diameter of 2 inches, subrounded to subangular; 40% sand, well graded, fine to medium grained, subangular; dry, no odor.	43.0	
NM		100			50			Total depth of borehole was 50.0 feet below ground surface.	50.0	
					55					
					60					
					65					
					70					
					75					

NEWGINT_SAC_AEROJET_120908.GPJ_NEWGINT.GDT 11/13/09



2295 Gateway Oaks
Suite 240
Sacramento, CA 95833
(916) 567-9900

BORING/WELL CONSTRUCTION LOG

PROJECT NUMBER 56111-6169.001.TK5.MOBIL BORING/WELL NUMBER CDM-CB-18
 PROJECT NAME Aerojet - GEDIT DATE DRILLED 12/3/08
 LOCATION Rancho Cordova, CA CASING TYPE/DIAMETER NA
 DRILLING METHOD Sonic SCREEN TYPE/SLOT NA
 SAMPLING METHOD Continuous Core GRAVEL PACK TYPE NA
 GROUND SURFACE ELEVATION (FT MSL) NA GROUT TYPE/QUANTITY Bentonite Grout
 TOP OF CASING ELEVATION (FT MSL) NA STATIC WATER LEVEL (FT BELOW TOC) NA
 LOGGED BY K. Hopfensperger GROUND WATER ELEVATION (FT MSL) _____
 REMARKS _____

PID (ppm)	BLOW COUNTS	RECOVERY (inches)	SAMPLE ID.	EXTENT	DEPTH (ft. bgs)	U.S.C.S.	GRAPHIC LOG	LITHOLOGIC DESCRIPTION	CONTACT DEPTH	WELL DIAGRAM
						GC		CLAYEY GRAVEL: light brown (5YR 5/6); 50% gravel, well graded, medium to coarse grained, maximum diameter of 2 inches, rounded to subrounded; 50% clay, soft, moderate to high plasticity; dry, no odor.	2.0	No well constructed. Borehole abandoned with bentonite grout.
NM		100			5			CLAY: light brown (5YR 5/6); 100% clay, soft, moderate to high plasticity; dry, no odor.		
NM		100			10	CL				
NM		100			15			CLAY: light brown (5YR 5/6); 100% clay, soft, moderate to high plasticity; dry, no odor.	15.0	
NM		100			20	CL				
NM		100			25					
						GC		CLAYEY GRAVEL: light brown (5YR 5/6); 50% gravel, well graded, fine to coarse grained, maximum diameter of 1 inch, subrounded to subangular; 50% clay, soft, moderate to high plasticity; dry, no odor.	27.0	
NM		100			30					
						GW		GRAVEL WITH SAND: moderate brown (5YR 4/4); 60% gravel, well graded, fine to coarse grained, maximum diameter of 2 inches, subrounded to subangular; 40% sand, well graded, fine to coarse grained, subangular to angular; dry, no odor.	32.0	
					35				35.0	

Continued Next Page





2295 Gateway Oaks
Suite 240
Sacramento, CA 95833
(916) 567-9900

BORING/WELL CONSTRUCTION LOG

PROJECT NUMBER 56111-6169.001.TK5.MOBIL BORING/WELL NUMBER CDM-CB-18
PROJECT NAME Aerojet - GEDIT DATE DRILLED 12/3/08

Continued from Previous Page

PID (ppm)	BLOW COUNTS	RECOVERY (inches)	SAMPLE ID.	EXTENT	DEPTH (ft. bgs)	U.S.C.S.	GRAPHIC LOG	LITHOLOGIC DESCRIPTION	CONTACT DEPTH	WELL DIAGRAM
NM		100				CL		GRAVELLY CLAY: light brown (5YR 5/6); 60% clay, soft, high plasticity; 40% gravel, well graded, fine to coarse grained, maximum diameter of 2 inches, subangular to subrounded; dry, no odor.	39.0	
NM		75			40	GM		SILTY GRAVEL WITH SAND: light brown (5YR 5/6); 60% gravel, well graded, fine to coarse grained, maximum diameter of 2 inches, subangular to subrounded; 20% sand, well graded, fine to coarse grained, subangular; 20% silt, soft, low to moderate plasticity; dry, no odor.		
NM		75			45	GM			50.0	
NM		75			50			Total depth of borehole was 50.0 feet below ground surface.		
					55					
					60					
					65					
					70					
					75					

NEWGINT_SAC_AEROJET_120908.GPJ_NEWGINT.GDT 11/13/09



2295 Gateway Oaks
Suite 240
Sacramento, CA 95833
(916) 567-9900

BORING/WELL CONSTRUCTION LOG

PROJECT NUMBER 56111-6169.001.TK5.MOBIL BORING/WELL NUMBER CDM-CB-19
 PROJECT NAME Aerojet - GEDIT DATE DRILLED 12/3/08
 LOCATION Rancho Cordova, CA CASING TYPE/DIAMETER NA
 DRILLING METHOD Sonic SCREEN TYPE/SLOT NA
 SAMPLING METHOD Continuous Core GRAVEL PACK TYPE NA
 GROUND SURFACE ELEVATION (FT MSL) NA GROUT TYPE/QUANTITY Bentonite Grout
 TOP OF CASING ELEVATION (FT MSL) NA STATIC WATER LEVEL (FT BELOW TOC) NA
 LOGGED BY K. Hopfensperger GROUND WATER ELEVATION (FT MSL) _____
 REMARKS _____

PID (ppm)	BLOW COUNTS	RECOVERY (inches)	SAMPLE ID.	EXTENT	DEPTH (ft. bgs)	U.S.C.S.	GRAPHIC LOG	LITHOLOGIC DESCRIPTION	CONTACT DEPTH	WELL DIAGRAM
NM	100				5	CL		CLAY: light brown (5YR 5/6); 100% clay, soft, high plasticity; dry, no odor.		No well constructed. Borehole abandoned with bentonite grout.
NM	100				10					
NM	100				15	GM		SILTY GRAVEL: light brown (5YR 5/6); 60% gravel, well graded, fine to coarse grained, maximum diameter of 2 inches, angular to subangular; 40% silt, soft, low plasticity; dry, no odor.	14.0	
						CL		CLAY: light brown (5YR 5/6); 100% clay, soft, high plasticity; dry, no odor.	16.0	
NM	100				20			SILTY GRAVEL: light brown (5YR 5/6); 50% gravel, well graded, fine to coarse grained, maximum diameter of 3 inches, rounded to subrounded; 50% silt, soft, low plasticity; dry, no odor.	19.0	
						GM				
NM	100				25					
NM	100				30			GRAVEL WITH SILT AND SAND: light brown (5YR 5/6); 60% gravel, well graded, fine to coarse grained, maximum diameter of 2 inches, subangular to angular; 30% sand, well graded, fine to coarse grained, subangular; 10% silt, soft, low plasticity; dry, no odor.	28.0	
						GW-GM				
					35				35.0	

Continued Next Page

NEWGINT_SAC_AEROJET_120908.GPJ NEWGINT.GDT 11/13/09



2295 Gateway Oaks
Suite 240
Sacramento, CA 95833
(916) 567-9900

BORING/WELL CONSTRUCTION LOG

PROJECT NUMBER 56111-6169.001.TK5.MOBIL BORING/WELL NUMBER CDM-CB-19
PROJECT NAME Aerojet - GEDIT DATE DRILLED 12/3/08

Continued from Previous Page

PID (ppm)	BLOW COUNTS	RECOVERY (inches)	SAMPLE ID.	EXTENT	DEPTH (ft. bgs)	U.S.C.S.	GRAPHIC LOG	LITHOLOGIC DESCRIPTION	CONTACT DEPTH	WELL DIAGRAM
NM		100						GRAVEL WITH SILT AND SAND: light brown (5YR 5/6); 60% gravel, well graded, fine to coarse grained, maximum diameter of 2 inches, subrounded to subangular; 30% sand, well graded, fine to coarse grained, subrounded to subangular; 10% silt, soft, low plasticity; dry, no	50.0	
NM		50								
NM		100								
NM		100								
								Total depth of borehole was 50.0 feet below ground surface.		
					40					
					45					
					50					
					55					
					60					
					65					
					70					
					75					

NEWGINT_SAC_AEROJET_120908.GPJ NEWGINT.GDT 11/13/09

Appendix C: Supplemental Data

Phase II Piezometer Monitoring Data

Well ID P1 Depth various

Date	Time	Well or Injection Gas Sample						Well	Ambient Air	Estimated Depth	
		O ₂ (%)	CO ₂ (%)	Propane (%)	H ₂ (%)	He (ppm)	RH (%)	Pressure (in wc)	Temperature (C°)	Barometric pressure (mbar)	(ft bgs)
Optimization Test #8 (100 cfh of 100% Propane to P4-18, & P4-28 (50 cfh to each point))											
9/8/2008	0905	Test Start									
9/8/2008	Tubing to P1 cut at all points, will measure next visit									999	
9/15/2008	954	5.4	1.62	30	0.002			32.3	24.1	1007	
9/15/2008	955	19.4	0.24	0.06	0.002			32.5	24.3	1007	
9/15/2008	958	5.9	1.94	3.5	0.002			32.4	24.7	1007	
9/15/2008	959	9.5	1.58	2.5	0.002			33.3	24.8	1007	
11/2/2008	1320	4.0	2.10	30	0.005			73.2	19.1	1016	
11/2/2008	1322	0.0	2.08	30	0.005			77.7	19.1	1016	
11/2/2008	1323	12.1	2.00	0.70	0.005			77.2	19.1	1016	
11/2/2008	1325	16.6	1.96	1.58	0.005			80.1	19.2	1016	
11/17/2008	1136	15.3	1.66	2.5	0.005			80.5	26.6	1014	
11/17/2008	1138	3.7	1.94	30	0.005			38.2	27.5	1014	
11/17/2008	1140	0.0	1.72	30	0.005			60.9	28.7	1014	
11/17/2008	1141	9.8	2.24	2.0	0.005			55.5	29.2	1014	
12/1/2008	1049	15.5	1.74	2.5	0.005			38.1	20.4	1014	
12/1/2008	1051	3.6	2.18	30	0.002			67.9	20.5	1014	
12/1/2008	1052	0.0	1.64	30	0.002			66.5	20.8	1014	
12/1/2008	1053	9.5	2.46	3.5	0.002			62.5	20.9	1014	

Aerojet GEDIT - Injection Test Input

Phase II Piezometer Monitoring Data

Well ID P1

Depth 18

Date	Time	Well or Injection Gas Sample						Well	Ambient Air		
		O ₂ (%)	CO ₂ (%)	Propane (%)	H ₂ (%)	He (ppm)	RH (%)	Pressure (in wc)	Temperature (C°)	Barometric pressure (mbar)	
12/12/2007	1353	20.6	0.20	0	0.002	100,000	77.1	0.02	10.8	1020	
12/12/2007	1544							0.02			
12/13/2007	1038	20.4	0.00	0	0.22		58.1		11.3		
12/13/2007	1200	Discovered leak in O2 - all O2 data for 12/13/07 before 1200 invalid									
12/13/2007	1357	19.9	0.38	0	0.022		67.9		13.4	1013	
12/14/2007	903	20.4	0.32	0	0.22		69.5	0.01	8.3	1017	
12/21/2007	1249	20.9	0.32	0	0.022		76.0	0.05	11.4	1012	
12/26/2007	1121	20.9	0.36	0	0.002		72.1	0.03	10.2	1017	
12/27/2007	1102	20.7	0.44	0	0.022		70.6	0.04	6.6	1017	
12/27/2007	1347	20.2	0.32	0	0.022		76.8		9	1016	
12/27/2007	1512	20.3	0.34	0	0.022		80.5		8.4	1017	
1/2/2008	1114	20.8	0.40	0	0.022		50	0.02	16.3	1012	

Tracer Test #1 (10 cfm to INJ2, ~7% H2)										
1/21/2008	1046 Test start									
1/21/2008	1203	13.3	0.48	0	0.10		75.6	0.03	10.0	1007
1/21/2008	1335	14.0	0.42	0	0.22		69.6		11.2	1006
1/21/2008	1504	14.6	0.40	0	0.22		75.5		10.9	1006
1/22/2008	939	16.7	0.36	0.02	0.22		75.3	0.02	6.6	1011
1/22/2008	1358	16.9	0.32	0	0.10		79.2		8.6	1009

Aerojet GEDIT - Injection Test Input

Phase II Piezometer Monitoring Data

Well ID P1

Depth 18

Date	Time	Well or Injection Gas Sample						Well	Ambient Air	
		O ₂ (%)	CO ₂ (%)	Propane (%)	H ₂ (%)	He (ppm)	RH (%)	Pressure (in wc)	Temperature (C°)	Barometric pressure (mbar)
1/23/2008	1004	17.9	0.34	0	0.22		77.1	0.06	8.9	1007
1/23/2008	1150*	17.6								

Tracer Test #2 (20 cfm to INJ2, ~8% H2)										
1/18/2008	1120 Test start									
1/18/2008	1222	12.2	0.42	0	1.2		68.5		13.3	1015
1/18/2008	1339	12.6	0.38	0	1.1		69.9		16.1	1014
1/18/2008	1459	12.7	0.36	0	1.1		55.5	0.02	17.7	1014
1/19/2008	920	14.0	0.46	0	0.79		60.7	0.02	7.4	1019
1/19/2008	1121*	13.1	0.46	0	0.75		43.0		18.9	1018

Tracer Test #3 (30 cfm to INJ2, ~4% H2)										
1/30/2008	1036 Test start									
1/30/2008	1129	11.9	0.52	0	0.77		83.4	0.04	10.0	1020
1/30/2008	1245	11.4	0.50	0	0.81		77.4		11.2	1019
1/30/2008	1449	11.3	0.48	0	0.81		66.4	0.06	15.0	1018
1/31/2008	1006	5.5	0.52	0	0.66		81.9	0.07	9.4	1019
1/31/2008	1144	5.7	0.52	0	0.46		81.0		9.6	1018
1/31/2008	1407	7.2	0.52	0	0.22		81.6	0.10	8.7	1016
1/31/2008	1435									
1/31/2008	1535	10.5	0.52	0	0.22		84.9	0.05	8.4	1014

Aerojet GEDIT - Injection Test Input

Phase II Piezometer Monitoring Data

Well ID P1

Depth 18

Date	Time	Well or Injection Gas Sample						Well	Ambient Air
		O ₂ (%)	CO ₂ (%)	Propane (%)	H ₂ (%)	He (ppm)	RH (%)	Pressure (in wc)	Temperature (C°)

Tracer Test #4 (60 cfm to INJ2, ~7% H2)										
1/28/2008	1236									
1/28/2008	1356	19.5	0.40	0	0.002		59.0		16.4	1010
1/28/2008	1633	18.8	0.44	0	0.001		74.6	0.07	8.9	1012
1/29/2008	821	8.9	0.54	0	2.2		80.8	0.05	5.1	1017
1/29/2008	Final O2*	8.9								

Tracer Test #5 (90 cfm to INJ2, ~3% H2)										
2/5/2008	1015									
2/5/2008	1152	17.3	0.26	0	0.010		73.2	0.08	11.2	1019
2/5/2008	1358	15.8	0.30	0	0.010		78	0.08	12.8	1018
2/5/2008	1521	14.0	0.38	0	0.010		47.1		22.5	1019
2/5/2008	1605	12.4	0.38	0	0.005		54.5		19.6	1018

Tracer Test #6 (30 cfm total; 10 cfm to each INJ1, 2, and 3; ~8% H2)										
2/7/2008	1500									
2/7/2008	1545	0.3	0.42	0	0.86		56.7		22.3	1016
2/7/2008	1634	0.3	0.42	0	0.66		56.8		20.1	1016
2/8/2008	1027	0.2	0.32	0	1.2		68.6		10.0	1017
2/8/2008	1100	0.2	0.30	0	1.3		74.3		11.1	1017

Aerojet GEDIT - Injection Test Input

Phase II Piezometer Monitoring Data Well ID P1 Depth 18

Date	Time	Well or Injection Gas Sample						Well	Ambient Air	
		O ₂ (%)	CO ₂ (%)	Propane (%)	H ₂ (%)	He (ppm)	RH (%)	Pressure (in wc)	Temperature (C°)	Barometric pressure (mbar)
Tracer Test #7 (60 cfm total; 20 cfm to each INJ1, 2, and 3, ~5% H2)										
1/17/2008	900	Test start								
1/17/2008	1430	19.1	0.40	0	0.22			61.7	13.8	1013
1/17/2008	1529	18.0	0.40	0	0.22		0.04	44.2	19.0	1012
1/17/2008	1556	17.0	0.40	0	0.82			38.8	20.2	1012
Tracer Test #8 (90 cfm total; 30 cfm each to INJ1, 2, and 3; ~4.5% H2)										
2/6/2008	1000	Test start								
2/6/2008	1055	5.4	0.40	0	0.62		0.09	78.4	11.1	1020
2/6/2008	1206	2.9	0.40	0	0.72			73.9	13.4	1020
2/6/2008	1301	1.5	0.40	0	0.56			73.0	14.5	1019
2/6/2008	1453	0.4	0.34	0	1.5		0.08	73.4	16.1	1017
2/6/2008	1551	0.3	0.32	0	2.0			57.7	19.1	1017
2/6/2008	1637	0.2	0.44	0	2.6			54.5	19.4	1017
Optimization Test #1 (90 cfm to INJ2 for 4 hours then shut down; ~88% N2, 10% H2, 1% CO2 & LPG)										
2/20/2008	1124	19.2	0.28	0	0.01			69.8	15.1	1010
2/20/2008	1206	Test start								
2/20/2008	1606	Test End								
2/20/2008	1616	17.3	0.34	0	0.005			45.1	22.8	1008
2/21/2008	923	18.0	0.24	0	0.01			73.9	10.8	1005
2/22/2008	1030	18.7	0.24	0	0.01			82	9.8	1003

Aerojet GEDIT - Injection Test Input

Phase II Piezometer Monitoring Data

Well ID P1

Depth 18

Date	Time	Well or Injection Gas Sample						Well	Ambient Air	
		O ₂ (%)	CO ₂ (%)	Propane (%)	H ₂ (%)	He (ppm)	RH (%)	Pressure (in wc)	Temperature (C°)	Barometric pressure (mbar)
Optimization Test #2 (30 cfm to INJ2 for 12 hours then shut down; ~88% N2, 10% H2, 1% CO2 & LPG)										
2/25/2008	1845	Test Start								
2/26/2008	653	Test End								
2/26/2008	725	19.1	0.44	0.08	0.005			88.8	4.1	1017
2/27/2008	1553	18.8	0.2	0	0.005			29.3	39	1009
2/28/2008	1044	19.9	0.18	0	0.01			73.8	15.7	1008
Optimization Test #3A (1 cfm to INJ2; ~88% N2, 10% H2, 1% CO2 & LPG)										
2/29/2008	1319	Test Start								
2/29/2008	1455	19.1	0.1	0	0.005			47.4	31.1	1009
3/3/2008	1038	19.1	0.12	0	0.002			63.1	14.8	1019
3/3/2008	1130	Test End								
Optimization Test #3B (1 cfm to INJ1, INJ2 & INJ3; ~88% N2, 10% H2, 1% CO2 & LPG)										
3/3/2008	1130	Test Start								
3/4/2008	949	19.1	0.16	0	0.01			57.7	14	1013
3/7/2008	1049	19	0.06	0	0.01			60.8	18.3	1018
3/7/2008	1306	Test End								
Optimization Test #3C (90 cfm to INJ1, INJ2 & INJ3 for 15 minutes then shut down; ~79% N2, 10% H2 & LPG, 1% CO2)										
3/7/2008	1306	Start Pulse								
3/7/2008	1321	End Pulse								
3/10/2008	1047	19.1	0.12	0	0.022			62.6	16.3	1016

Aerojet GEDIT - Injection Test Input

Phase II Piezometer Monitoring Data

Well ID P1

Depth 18

Date	Time	Well or Injection Gas Sample						Well	Ambient Air
		O ₂ (%)	CO ₂ (%)	Propane (%)	H ₂ (%)	He (ppm)	RH (%)	Pressure (in wc)	Temperature (C°)
Optimization Test #4 (2, 45-minutes pulses; daily 15-minutes pulses w/30cfh constant flow)									
Optimization Test #5 (20 cfm to INJ2 for 125 minutes while maintaing 30 cfh the rest of the time; ~80% N2, 10% H2 & LPG)									
Optimization Test #6 (50 cfh to P4-18 & P4-28; ~80% N2, 10% H2 & LPG)									
3/20/2008	1330	Start Test							
3/26/2008	1014	20.3	0.16	0	0.005		53.8	11.8	1017
3/28/2008	936	20.0	0.24	0	0.01		57.6	9.7	1009
3/31/2008	937	20.0	0.24	0	0.01		72.8	8.6	1013
4/2/2008	1100	18.7	0.22	0.3	0.022		60.3	15.9	1008
Optimization Test #7 (20 cfh to P4-18, --28, -38 (60 cfh total); ~80% N2, 10% H2 & LPG)									
4/2/2008	1233	Start Test							
4/4/2008	945	17.6	0.18	0.56	0.022		57.7	13.1	1013
4/7/2008	1414	17.5	0.24	0.7	0.022		61.0	19.2	1011
Optimization Test #7B (30 cfh to P4-18, & P4-28 (60 cfh total); ~80% N2, 10% H2 & LPG)									
4/7/2008	1458	Start Test							
4/9/2008	1112	16.2	0.16	1.0	0.01		66.4	15.0	1009

Aerojet GEDIT - Injection Test Input

Phase II Piezometer Monitoring Data

Well ID P1

Depth 18

Date	Time	Well or Injection Gas Sample						Well	Ambient Air	
		O ₂ (%)	CO ₂ (%)	Propane (%)	H ₂ (%)	He (ppm)	RH (%)	Pressure (in wc)	Temperature (C°)	Barometric pressure (mbar)
Optimization Test #7C (50 cfh to P4-18, & P4-28 (100 cfh total); ~79% N2, 10% H2 & LPG, 1% CO2)										
4/10/2009	1121	Start Test								
4/11/2008	1237	17.4	0.22	0.8	0.0		52.3	22.3	1012	
4/16/2008	1033	15.1	0.20	1.26	0.01		50.1	15.9	1011	
4/22/2008	1021	16.1	0.26	1.12	0.005		55.6	17.4	1009	
4/25/2008	1004	9.7	0.28	3.0	0.010		43.9	23.2	1015	
4/29/2008	1114	12.3	0.28	2.5	0.005		55.8	23.8	1007	
5/5/2008	1318	10.6	0.26	3.0	0.010		49.2	36.1	1001	
5/13/2008	940	8.1	0.28	5.0	0.002		21.2	34.6	1007	
5/20/2008	939	11.9	0.34	2.5	0.002		34.2	26.6	1004	
5/23/2008	1525	8	0.36	4.0	0.005		28.3	29.8	990	
5/27/2008	911	13.1	0.52	2.5	0.002		44.6	17.0	1007	
6/4/2008	913	11.7	0.46	3.0	0.005		36.8	25.8	1002	
6/12/2008	1205	8.4	0.50	4.5	0.005		26.4	42.0	1003	
6/20/2008	1032	8.8	0.60	4.0	0.046		30.2	40.1	1005	
6/25/2008	1053	8.8	0.62	3.5	0.005		36.9	33.0	1005	
7/2/2008	1154	9.3	0.76	3.5	0.010		66.4	30.4	1004	
7/7/2008	1141	7.6	0.66	4.5	0.046		51	36.3	998	
7/18/2008	1106	8.6	0.84	4	0.002		71.9	26.0		
7/24/2008	1023	8.5	0.92	4.0	0.005		53.0	26.5	1005	
7/31/2008	1019	8.5	1.08	3.5	0.010		54.0	25.6	1003	
8/7/2008	900	7.5	1.08	4.5	0.010		46.1	20.6	1004	
8/12/2008	1003	7.1	1.04	4.5	0.005		42.8	28.0	1002	

Aerojet GEDIT - Injection Test Input

Phase II Piezometer Monitoring Data

Well ID P1

Depth 18

Date	Time	Well or Injection Gas Sample						Well	Ambient Air	
		O ₂ (%)	CO ₂ (%)	Propane (%)	H ₂ (%)	He (ppm)	RH (%)	Pressure (in wc)	Temperature (C°)	Barometric pressure (mbar)
Optimization Test #8 (100 cfh of 100% Propane to P4-18, & P4-28 (50 cfh to each point)										
9/8/2008	0905 Test Start									
9/8/2008	Tubing to P1 cut at all points, will measure next visit									999
9/29/2008	Tubing to P1 cut again at all points,									
11/17/2008	1136	15.3	1.66	2.5	0.005		80.5	26.6	1014	

Aerojet GEDIT - Injection Test Input

Phase II Piezometer Monitoring Data

Well ID P1

Depth 33

Date	Time	Well or Injection Gas Sample							Well	Ambient Air	
		O ₂ (%)	CO ₂ (%)	Propane (%)	H ₂ (%)	He (ppm)	RH (%)	Pressure (in wc)	Temperature (C°)	Barometric pressure (mbar)	
12/12/2007	1355	19.9	0.68	0	0.002	100,000	78.6	0.06	10.9	1020	
12/12/2007	1543							0.06			
12/13/2007	1040	20.4	0	0	0.22		63.4		10.5	1016	
12/13/2007	1200	Discovered leak in O2 - all O2 data for 12/13/07 before 1200 invalid									
12/13/2007	1359	12.7	0.80	0	2.2		69.1		13.2	1013	
12/14/2007	904	14.5	0.90	0	0.75		66.3	0.02	8.6	1017	
12/21/2007	1252	20.6	1.24	0	0.022		78.2	0.03	11.1	1012	
12/26/2007	1125	20.9	1.2	0	0.002		71.6	0.02	10.6	1017	
12/27/2007	1105	20.5	1.28	0	0.022		77.4	0.03	6.5	1017	
12/27/2007	1349	20.2	1.04	0	0.022		81		9	1016	
12/27/2007	1514	20.2	1.04	0	0.022		82.5		8.3	1017	
1/2/2008	1118	20.5	1.2	0	0.022		44.7	0.03	18.1	1012	

Tracer Test #1 (10 cfm to INJ2, ~7% H2)										
1/21/2008	1046 Test start									
1/21/2008	1204	7.7	0.44	0	0.046		77.0	0.05	10.0	1007
1/21/2008	1336	6.9	0.42	0	0.046		71.6		11.1	1006
1/21/2008	1506	6.6	0.42	0	0.022		76.1		11.0	1006
1/22/2008	942	6.9	0.48	0	0.022		75.9	0.03	6.7	1011
1/22/2008	1400	6.9	0.46	0	0.046		79.5		8.7	1009
1/23/2008	1006	10.8	0.58	0	0.022		78.0	0.04	8.0	1007
1/23/2008	1153*	10.1								

Aerojet GEDIT - Injection Test Input

Phase II Piezometer Monitoring Data

Well ID P1

Depth 33

Date	Time	Well or Injection Gas Sample							Well	Ambient Air
		O ₂ (%)	CO ₂ (%)	Propane (%)	H ₂ (%)	He (ppm)	RH (%)	Pressure (in wc)	Temperature (C°)	Barometric pressure (mbar)

Tracer Test #2 (20 cfm to INJ2, ~8% H2)											
1/18/2008	1120	Test start									
1/18/2008	1225	5.4	0.36	0	0.10			68.8		13.4	1015
1/18/2008	1340	5.8	0.34	0	0.046			70.7		15.2	1014
1/18/2008	1500	5.8	0.32	0	0.50			57.5	0.03	17.7	1014
1/19/2008	922	6.7	0.54	0	0.62			69.6	0.02	7.3	1019
1/19/2008	1129*	5.2	0.52	0				46.6		17.7	1018

Tracer Test #3 (30 cfm to INJ2, ~4% H2)											
1/30/2008	1036	Test start									
1/30/2008	1130	1.6	0.36	0	0.46			82.4	0.06	10.0	1020
1/30/2008	1246	1.3	0.34	0	0.1			75.3		11.3	1019
1/30/2008	1451	1.1	0.30	0	0.046			65.2	0.08	15.0	1018
1/31/2008	1008	1.8	0.32	0	1.9			80.6	0.09	9.5	1019
1/31/2008	1146	1.9	0.34	0	1.7			81.0		9.6	1018
1/31/2008	1409	2.2	0.32	0	1.5			80.3	0.10	8.7	1016
1/31/2008	1435										
1/31/2008	1536	2.4	0.34	0	1.1			81.9	0.06	8.4	1014

Aerojet GEDIT - Injection Test Input

Phase II Piezometer Monitoring Data

Well ID P1

Depth 33

Date	Time	Well or Injection Gas Sample						Well	Ambient Air
		O ₂ (%)	CO ₂ (%)	Propane (%)	H ₂ (%)	He (ppm)	RH (%)	Pressure (in wc)	Temperature (C°)
Tracer Test #4 (60 cfm to INJ2, ~7% H2)									
1/28/2008	1236	Test start							
1/28/2008	1357	17.3	0.86	0	0.002		63.0	15.6	1010
1/28/2008	1634	10.7	0.74	0	0.98		78.0	0.09	8.8
1/29/2008	822	4.3	0.62	0	4.9		79.9	0.03	5.1
1/29/2008	Final O2*	4.3							
Tracer Test #5 (90 cfm to INJ2, ~3% H2)									
2/5/2008	1015	Test start							
2/5/2008	1153	8.4	0.38	0	0.022		73.8	0.10	11.2
2/5/2008	1359	5.7	0.34	0	1.1		78.9	0.12	12.8
2/5/2008	1522	4.9	0.38	0	1.5		44.8		22.9
2/5/2008	1606	4.5	0.36		1.6		55.3		19.5
Tracer Test #6 (30 cfm total; 10 cfm to each INJ1, 2, and 3; ~8% H2)									
2/7/2008	1500	Test start							
2/7/2008	1547	0.6	0.18	0	0.046		55.2		22.8
2/7/2008	1636	0.5	0.16	0	0.10		55.6		20.3
2/8/2008	1029	0.6	0.14	0	6.6		70.0		10.0
2/8/2008	1101	0.6	0.12	0	6.6		72.4		11.1

Aerojet GEDIT - Injection Test Input

Phase II Piezometer Monitoring Data

Well ID P1

Depth 33

Date	Time	Well or Injection Gas Sample						Well	Ambient Air	
		O ₂ (%)	CO ₂ (%)	Propane (%)	H ₂ (%)	He (ppm)	RH (%)	Pressure (in wc)	Temperature (C°)	Barometric pressure (mbar)
Tracer Test #7 (60 cfm total; 20 cfm to each INJ1, 2, and 3, ~5% H2)										
1/17/2008	900	Test start								
1/17/2008	1132	10.3	0.54	0	2.9		72.6	0.05	10.0	1015
1/17/2008	1236	9.5	0.52	0	3.7		74.4		10.7	1014
1/17/2008	1432	8.2	0.72	0	4.4		64.3		13.8	1013
1/17/2008	1531	7.6	0.66	0	4.7		45.0	0.04	18.9	1012
1/17/2008	1558	7.2	0.64	0	4.9		39.7		19.8	1012
Tracer Test #8 (90 cfm total; 30 cfm each to INJ1, 2, and 3; ~4.5% H2)										
2/6/2008	1000	Test start								
2/6/2008	1057	1.7	0.22	0	0.98		79.2	0.14	11.1	1020
2/6/2008	1208	1.5	0.20	0	2.6		75.1		13.4	1020
2/6/2008	1302	1.4	0.18	0	2.9		72.5		14.6	1019
2/6/2008	1456	1.3	0.16	0	3.7		72.0	0.16	16.1	1017
2/6/2008	1553	1.1	0.12	0	3.8		58.5		19.1	1017
2/6/2008	1639	1.2	0.20	0	3.9		54.1		19.4	1017
Optimization Test #1 (90 cfm to INJ2 for 4 hours then shut down; ~88% N2, 10% H2, 1% CO2 & LPG)										
2/20/2008	1126	17.8	0.56	0	0.01		69.7		15.2	1010
2/20/2008	1206	Test start								
2/20/2008	1606	Test End								
2/20/2008	1617	11.9	0.42	0.1	2.8		46.5		22.7	1008
2/21/2008	924	17.3	0.54	0.02	0.022		73.2		10.7	1004
2/22/2008	1031	18.2	0.6	0	0.01		79.9		9.7	1003

Aerojet GEDIT - Injection Test Input

Phase II Piezometer Monitoring Data

Well ID P1

Depth 33

Date	Time	Well or Injection Gas Sample						Well	Ambient Air	
		O ₂ (%)	CO ₂ (%)	Propane (%)	H ₂ (%)	He (ppm)	RH (%)	Pressure (in wc)	Temperature (C°)	Barometric pressure (mbar)
Optimization Test #2 (30 cfm to INJ2 for 12 hours then shut down; ~88% N2, 10% H2, 1% CO2 & LPG)										
2/25/2008	1845	Test Start								
2/26/2008	653	Test End								
2/26/2008	730	16.7	0.78	0.14	0.046		86.8	4.3	1017	
2/27/2008	1556	18.1	0.56	0	0.002		28	38.5	1009	
2/28/2008	1046	18.8	0.56	0	0.005		74.1	15.7	1007	
Optimization Test #3A (1 cfm to INJ2; ~88% N2, 10% H2, 1% CO2 & LPG)										
2/29/2008	1319	Test Start								
2/29/2008	1456	18.5	0.42	0	0.002		46.8	31.3	1009	
3/3/2008	1039	19	0.52	0	0.002		59.6	14.8	1019	
3/3/2008	1130	Test End								
Optimization Test #3B (1 cfm to INJ1, INJ2 & INJ3; ~88% N2, 10% H2, 1% CO2 & LPG)										
3/3/2008	1130	Test Start								
3/4/2008	950	19.1	0.56	0	0.005		56.9	14.1	1013	
3/7/2008	1050	18.8	0.44	0	0.005		57.1	18.2	1018	
3/7/2008	1306	Test End								
Optimization Test #3C (90 cfm to INJ1, INJ2 & INJ3 for 15 minutes then shut down; ~79% N2, 10% H2 & LPG, 1% CO2)										
3/7/2008	1306	Start Pulse								
3/7/2008	1321	End Pulse								
3/10/2008	1048	19	0.52	0	0.005		61.7	16.3	1016	

Aerojet GEDIT - Injection Test Input

Phase II Piezometer Monitoring Data

Well ID P1

Depth 33

Date	Time	Well or Injection Gas Sample						Well	Ambient Air	
		O ₂ (%)	CO ₂ (%)	Propane (%)	H ₂ (%)	He (ppm)	RH (%)	Pressure (in wc)	Temperature (C°)	Barometric pressure (mbar)
Optimization Test #4 (2, 45-minutes pulses; daily 15-minutes pulses w/30cfh constant flow)										
Optimization Test #5 (20 cfm to INJ2 for 125 minutes while maintaing 30 cfh the rest of the time; ~80% N2, 10% H2 & LPG)										
Optimization Test #6 (50 cfh to P4-18 & P4-28; ~80% N2, 10% H2 & LPG)										
3/20/2008	1330	Start Test								
3/26/2008	1015		18.7	0.54	0.26	0.005		24.0	11.8	1017
3/28/2008	937		19.0	0.62	0.12	0.01		53.4	9.8	1009
3/31/2008	938		18.0	0.56	0.72	0.01		70.2	8.7	1013
4/2/2008	1102		10.3	0.34	6.5	0.46		65.7	16.1	1008
Optimization Test #7 (20 cfh to P4-18, --28, -38 (60 cfh total); ~80% N2, 10% H2 & LPG)										
4/2/2008	1233	Start Test								
4/4/2008	946		8.9	0.26	7.5	0.046		56.2	13.1	1013
4/7/2008	1415		11.8	0.38	4.5	0.01		60.4	19.3	1011
Optimization Test #7B (30 cfh to P4-18, & P4-28 (60 cfh total); ~80% N2, 10% H2 & LPG)										
4/7/2008	1458	Start Test								
4/9/2008	1114		12.6	0.34	3.5	0.005		62.0	15.0	1009

Aerojet GEDIT - Injection Test Input

Phase II Piezometer Monitoring Data

Well ID P1

Depth 33

Date	Time	Well or Injection Gas Sample							Well	Ambient Air
		O ₂ (%)	CO ₂ (%)	Propane (%)	H ₂ (%)	He (ppm)	RH (%)	Pressure (in wc)	Temperature (C°)	Barometric pressure (mbar)
Optimization Test #7C (50 cfh to P4-18, & P4-28 (100 cfh total); ~79% N2, 10% H2 & LPG, 1% CO2)										
4/10/2009	1121	Start Test								
4/11/2008	1240	13	0.46	3.0	0.0		62.8		22.7	1012
4/16/2008	1034	10.7	0.46	4.0	0.005		48.9		16.0	1011
4/22/2008	1022	12.5	0.56	2.5	0.005		57.3		17.5	1009
4/25/2008	1005	10.4	0.54	3.0	0.010		43.7		23.2	1015
4/29/2008	1115	10.0	0.54	3.5	0.005		55.3		24.0	1007
5/5/2008	1319	8.0	0.48	4.5	0.005		46.2		36.5	1001
5/13/2008	941	6.3	0.54	5.5	0.002		21.3		34.6	1007
5/20/2008	940	9.0	0.66	4.5	0.002		32.5		26.1	1004
5/23/2008	1526	9.2	0.56	4.0	0.005		28.1		29.7	990
5/27/2008	912	9.4	0.80	4.0	0.001		45.0		16.9	1007
6/4/2008	914	5.8	0.54	7.0	0.005		36.5		25.6	1002
6/12/2008	1207	4.8	0.54	7.0	0.005		26.5		42.2	1003
6/20/2008	1035	6.4	0.60	6.0	0.010		27.6		40.0	1005
6/25/2008	1054	4.9	0.66	6.5	0.005		36.8		33.1	1005
7/2/2008	1155	5.5	0.72	6.0	0.005		67.4		30.4	1004
7/7/2008	1142	5.2	0.66	6.0	0.01		58.6		36.3	998
7/18/2008	1109	4.2	0.84	7.0	0.002		73.1		26.3	
7/24/2008	1024	5.1	0.90	7.0	0.005		54.6		26.5	1005
7/31/2008	1021	4.7	1.02	7.0	0.005		52.7		25.6	1003
8/7/2008	901	4.4	1.04	7.5	0.005		38.1		20.6	1004
8/12/2008	1004	4.5	1.00	7.0	0.005		43.6		28.0	1002

Aerojet GEDIT - Injection Test Input

Phase II Piezometer Monitoring Data

Well ID P1

Depth 33

Date	Time	Well or Injection Gas Sample						Well	Ambient Air	
		O ₂ (%)	CO ₂ (%)	Propane (%)	H ₂ (%)	He (ppm)	RH (%)	Pressure (in wc)	Temperature (C°)	Barometric pressure (mbar)
Optimization Test #8 (100 cfh of 100% Propane to P4-18, & P4-28 (50 cfh to each point))										
9/8/2008	0905	Test Start								
9/8/2008	Tubing to P1 cut at all points, will measure next visit									999
9/29/2008	Tubing to P1 cut again at all points,									
11/17/2008	1138	3.7	1.94	30	0.005		38.2	27.5	1014	

Aerojet GEDIT - Injection Test Input

Phase II Piezometer Monitoring Data

Well ID P1

Depth 48

Date	Time	Well or Injection Gas Sample						Well	Ambient Air		
		O ₂ (%)	CO ₂ (%)	Propane (%)	H ₂ (%)	He (ppm)	RH (%)	Pressure (in wc)	Temperature (C°)	Barometric pressure (mbar)	
12/12/2007	1357	19.0	0.78	0	0.002	100,000	78.2	0.04	11.0	1020	
12/12/2007	1544							0.11			
12/13/2007	1043	20.4	0	0	0.022		67.0		9.8	1016	
12/13/2007	1200	Discovered leak in O2 - all O2 data for 12/13/07 before 1200 invalid									
12/13/2007	1400	18.6	1.14	0	0.22		68.6		13.1	1013	
12/14/2007	906	18.7	1.3	0	0.22		67.1	0.03	9.0	1017	
12/21/2007	1254	18.7	2.02	0	0.022		77.1	0.05	11.0	1012	
12/26/2007	1128	18.9	2.04	0	0.002		71.7	0.08	10.6	1017	
12/27/2007	1107	18.7	2.18	0	0.022		80.1	0.03	6.5	1017	
12/27/2007	1350	18.5	1.84	0	0.022		79.6		8.9	1016	
1/2/2008	1120	18.6	2.04	0	0.022		42.6	0.03	18.6	1012	

Tracer Test #1 (10 cfm to INJ2, ~7% H2)											
1/21/2008	1046	Test start									
1/21/2008	1206	19.1	1.52	0	0.010		76.3	0.06	10.0	1007	
1/21/2008	1337	19.0	1.36	0	0.010		72.0		11.1	1006	
1/22/2008	943	19.1	1.64	0	0.010		75.0	0.00	6.7	1011	
1/22/2008	1401	19.0	1.58	0	0.010		78.5		8.7	1009	
1/23/2008	1007	19.2	1.66	0	0.022		77.9	0.06	8.8	1007	
1/23/2008	1154*	19.1									

Aerojet GEDIT - Injection Test Input

Phase II Piezometer Monitoring Data

Well ID P1

Depth 48

Date	Time	Well or Injection Gas Sample						Well	Ambient Air
		O ₂ (%)	CO ₂ (%)	Propane (%)	H ₂ (%)	He (ppm)	RH (%)	Pressure (in wc)	Temperature (C°)

Tracer Test #2 (20 cfm to INJ2, ~8% H2)										
1/18/2008	1120 Test start									
1/18/2008	1227	18.8	1.44	0	0.010		64.3		13.4	1015
1/18/2008	1343	18.8	1.38	0	0.005		68.1		15.1	1014
1/18/2008	1502	18.8	1.34	0	0.022		56.4	0.02	17.7	1014
1/19/2008	925	19.2	1.88	0	0.010		58.9	0.02	7.3	1019
1/19/2008	1126*	18.6	1.84	0	0.002		47.4		16.8	1018

Tracer Test #3 (30 cfm to INJ2, ~4% H2)										
1/30/2008	1036 Test start									
1/30/2008	1132	18.5	2.10	0	0.010		81.8	0.04	10.1	1020
1/30/2008	1247	18.4	2.06	0	0.010		76.1		11.3	1019
1/30/2008	1453	18.2	2.04	0	0.005		65.7	0.08	14.9	1018
1/31/2008	1009	18.4	2.10	0	0.010		80.0	0.09	9.5	1019
1/31/2008	1147	18.5	2.08	0	0.010		81.2		9.6	1018
1/31/2008	1410	18.5	2.12	0	0.010		79.7	0.12	8.7	1016
1/31/2008	1435									
1/31/2008	1537	18.5	2.14	0	0.022		81.0	0.08	8.4	1014

Aerojet GEDIT - Injection Test Input

Phase II Piezometer Monitoring Data

Well ID P1

Depth 48

Date	Time	Well or Injection Gas Sample						Well	Ambient Air
		O ₂ (%)	CO ₂ (%)	Propane (%)	H ₂ (%)	He (ppm)	RH (%)	Pressure (in wc)	Temperature (C°)

Tracer Test #4 (60 cfm to INJ2, ~7% H2)										
1/28/2008	1236 Test start									
1/28/2008	1359	18.2	2.30	0	0.001		67.2		14.6	1010
1/28/2008	1637	18.4	2.24	0.02	0.010		77.0	0.08	8.8	1012
1/29/2008	824	18.3	2.36	0	0.010		80.4	0.03	5.1	1017
1/29/2008	Final O2*		18.3							

Tracer Test #5 (90 cfm to INJ2, ~3% H2)										
2/5/2008	1015 Test start									
2/5/2008	1155	18.0	1.32	0	0.010		74.4	0.12	11.2	1019
2/5/2008	1401	17.9	1.32	0	0.010		80.4	0.17	12.8	1018
2/5/2008	1523	18.4	1.40	0	0.010		45.6		22.8	1019
2/5/2008	1607	18.3	1.40	0	0.010		55.3		19.0	1018

Tracer Test #6 (30 cfm total; 10 cfm to each INJ1, 2, and 3; ~8% H2)										
2/7/2008	1500 Test start									
2/7/2008	1548	18.3	1.54	0	0.022		53.6		23.6	1016
2/7/2008	1636	18.3	1.52	0	0.022		55.1		20.4	1016
2/8/2008	1030	18.0	1.42	0	0.022		69.1		10.0	1017

Aerojet GEDIT - Injection Test Input

Phase II Piezometer Monitoring Data

Well ID P1

Depth 48

Date	Time	Well or Injection Gas Sample						Well	Ambient Air
		O ₂ (%)	CO ₂ (%)	Propane (%)	H ₂ (%)	He (ppm)	RH (%)	Pressure (in wc)	Temperature (C°)

Tracer Test #7 (60 cfm total; 20 cfm to each INJ1, 2, and 3; ~5% H2)										
1/17/2008	900 Test start									
1/17/2008	1136	19.1	1.24	0	0.022		67.0	0.03	10.0	1015
1/17/2008	1238	19.0	1.22	0	0.22		68.6		10.7	1014
1/17/2008	1435	19.2	1.66	0	0.022		62.4		13.8	1013
1/17/2008	1534	19.1	1.62	0	0.22		44.8	0.02	18.6	1012
1/17/2008	1559	19.1	1.64	0	0.22		39.7		19.4	1012

Tracer Test #8 (90 cfm total; 30 cfm each to INJ1, 2, and 3; ~4.5% H2)										
2/6/2008	1000 Test start									
2/6/2008	1058	18.0	1.34	0	0.010		76.7	0.12	11.2	1020
2/6/2008	1210	18.0	1.34	0	0.010		74.5		13.4	1019
2/6/2008	1303	17.9	1.32	0	0.010		73.2		14.5	1018
2/6/2008	1457	17.8	1.28	0	0.010		72.3	0.10	16.4	1017
2/6/2008	1554	17.6	1.24	0	0.010		58.4		19.0	1017

Aerojet GEDIT - Injection Test Input

Phase II Piezometer Monitoring Data

Well ID P1

Depth 48

Date	Time	Well or Injection Gas Sample						Well	Ambient Air
		O ₂ (%)	CO ₂ (%)	Propane (%)	H ₂ (%)	He (ppm)	RH (%)	Pressure (in wc)	Temperature (C°)
Optimization Test #1 (90 cfm to INJ2 for 4 hours then shut down; ~88% N2, 10% H2, 1% CO2 & LPG)									
2/20/2008	1127	18	1.72	0	0.01		68.7	15.2	1010
2/20/2008	1206 Test start								
2/20/2008	1606 Test End								
2/20/2008	1619	17.5	1.5	0	0.022		46.9	22.6	1008
2/21/2008	925	17.7	1.62	0	0.01		73.9	10.6	1005
2/22/2008	1032	17.7	1.64	0	0.005		79.9	9.7	1003
Optimization Test #2 (30 cfm to INJ2 for 12 hours then shut down; ~88% N2, 10% H2, 1% CO2 & LPG)									
2/25/2008	1845 Test Start								
2/26/2008	653 Test End								
2/26/2008	731	18.1	2	0.08	0.005		86.7	4.3	1017
2/27/2008	1558	16.9	1.4	0	0.002		28.2	38.3	1009
2/28/2008	1047	17.4	1.42	0	0.005		72.5	15.7	1007
Optimization Test #3A (1 cfm to INJ2; ~88% N2, 10% H2, 1% CO2 & LPG)									
2/29/2008	1319 Test Start								
2/29/2008	1458	17.1	1.18	0	0.002		48.1	31.8	1009
3/3/2008	1040	17.2	1.36	0	0.002		58.5	14.8	1019
3/3/2008	1130 Test End								

Aerojet GEDIT - Injection Test Input

Phase II Piezometer Monitoring Data

Well ID P1

Depth 48

Date	Time	Well or Injection Gas Sample						Well	Ambient Air
		O ₂ (%)	CO ₂ (%)	Propane (%)	H ₂ (%)	He (ppm)	RH (%)	Pressure (in wc)	Temperature (C°)
Optimization Test #3B (1 cfm to INJ1, INJ2 & INJ3; ~88% N2, 10% H2, 1% CO2 & LPG)									
3/3/2008	1130 Test Start								
3/4/2008	951	17.1	1.42	0	0.005		56.8	14.1	1013
3/7/2008	1051	16.9	1.18	0	0.005		57.4	18.1	1018
3/7/2008	1306 Test End								
Optimization Test #3C (90 cfm to INJ1, INJ2 & INJ3 for 15 minutes then shut down; ~79% N2, 10% H2 & LPG, 1% CO2)									
3/7/2008	1306 Start Pulse								
3/7/2008	1321 End Pulse								
Optimization Test #4 (2, 45-minutes pulses; daily 15-minutes pulses w/30cfh constant flow)									
Optimization Test #5 (20 cfm to INJ2 for 125 minutes while maintaing 30 cfh the rest of the time; ~80% N2, 10% H2 & LPG)									
Optimization Test #6 (50 cfh to P4-18 & P4-28; ~80% N2, 10% H2 & LPG)									
3/20/2008	1330 Start Test								
3/26/2008	1024	17.1	1.44	0	0.002		53.0	12.1	1017
3/28/2008	938	17.0	1.56	0	0.005		52.9	10.0	1009
3/31/2008	939	17.0	1.50	0	0.01		69.4	8.9	1013
4/2/2008	1104	17.1	1.42	0	0.01		58.3	16.1	1008

Aerojet GEDIT - Injection Test Input

Phase II Piezometer Monitoring Data

Well ID P1

Depth 48

Date	Time	Well or Injection Gas Sample						Well	Ambient Air
		O ₂ (%)	CO ₂ (%)	Propane (%)	H ₂ (%)	He (ppm)	RH (%)	Pressure (in wc)	Temperature (C°)
Optimization Test #7 (20 cfh to P4-18, --28, -38 (60 cfh total); ~80% N2, 10% H2 & LPG)									
4/2/2008	1233								
4/4/2008	947	16.9	1.44	0	0.01		56.2	13.2	1013
4/7/2008	1416	17.0	1.54	0.0	0.005		60.8	19.4	1011
Optimization Test #7B (30 cfh to P4-18, & P4-28 (60 cfh total); ~80% N2, 10% H2 & LPG)									
4/7/2008	1458								
4/9/2008	1116	16.5	1.32	0.0	0.005		63.9	15.0	1009
Optimization Test #7C (50 cfh to P4-18, & P4-28 (100 cfh total); ~79% N2, 10% H2 & LPG, 1% CO2)									
4/10/2009	1121								
4/11/2008	1241	16.8	1.44	0.0	0.0		52.8	22.6	1012
4/16/2008	1035	16.6	1.40	0.0	0.002		48.5	16.1	1011
4/22/2008	1024	16.7	1.48	0.02	0.005		53.5	17.7	1009
4/25/2008	1006	16.8	1.46	0.02	0.005		44.7	23.2	1015
4/29/2008	1116	16.6	1.40	0.04	0.005		52.1	24.0	1007
5/5/2008	1320	16.0	1.36	0.06	0.005		36.6	44.7	1001
5/13/2008	944	16.2	1.46	0.08	0.001		26.3	34.2	1007
5/20/2008	942	16.5	1.56	0.01	0.002		35.8	25.6	1004
5/23/2008	1527	16.0	1.30	0.02	0.005		28.6	29.5	990
5/27/2008	913	16.4	1.72	0.03	0.001		46.0	17.1	1007

Aerojet GEDIT - Injection Test Input

Phase II Piezometer Monitoring Data

Well ID P1

Depth 48

Date	Time	Well or Injection Gas Sample						Well	Ambient Air		
		O ₂ (%)	CO ₂ (%)	Propane (%)	H ₂ (%)	He (ppm)	RH (%)	Pressure (in wc)	Temperature (C°)	Barometric pressure (mbar)	
6/4/2008	916	15.7	1.56	0.03	0.002		37.0		25.1	1002	
6/12/2008	1208	14.9	1.50	0.42	0.002		22.7		42.6	1003	
6/20/2008	1036	14.6	1.44	0.5	0.005		26.5		40.7	1005	
6/25/2008	1055	14.3	1.44	0.56	0.005		36.1		33.4	1005	
7/2/2008	1156	13.8	1.48	0.64	0.005		67.2		30.3	1004	
7/7/2008	1144	13.5	1.36	0.68	0.005		49.8		36.3	998	
7/18/2008	1112	13.2	1.56	0.88	0.001		69.3		26.7		
7/24/2008	1026	13.0	1.56	1.0	0.005		52.9		26.5	1005	
7/31/2008	1022	12.7	1.72	1.1	0.005		50.1		25.5	1003	
8/7/2008	902	12.4	1.68	1.2	0.005		37.3		20.6	1004	
8/12/2008	1005	12.0	1.58	1.24	0.005		43.3		28.1	1002	
Optimization Test #8 (100 cfh of 100% Propane to P4-18, & P4-28 (50 cfh to each point)											
9/8/2008	0905 Test Start										
9/8/2008	Tubing to P1 cut at all points, will measure next visit										999
9/29/2008	Tubing to P1 cut again at all points,										
11/17/2008	1140	0.0	1.72	30	0.005		60.9		28.7	1014	

Aerojet GEDIT - Injection Test Input

Phase II Piezometer Monitoring Data

Well ID P1

Depth 68

Note - slight flow restriction on P1-68 feet

Date	Time	Well or Injection Gas Sample						Well	Ambient Air		
		O ₂ (%)	CO ₂ (%)	Propane (%)	H ₂ (%)	He (ppm)	RH (%)	Pressure (in wc)	Temperature (C°)	Barometric pressure (mbar)	
12/12/2007	1358	17.0	0.72	0	0.002	8x10^5	71.0	0.10	11.1	1020	
12/12/2007	1544							0.12			
12/13/2007	1041	20.4	0	0	0.22		65.7		10.1	1016	
12/13/2007	1200	Discovered leak in O2 - all O2 data for 12/13/07 before 1200 invalid									
12/13/2007	1400	12.7	1.98	0	0.22		67.9		12.9	1013	
12/14/2007	906	13.0	2.22	0	0.22		64.7	0.02	9.4	1017	
12/21/2007	1256	13.2	3.02	0	0.022		75.0	0.01	10.9	1012	
12/26/2007	1130	13.3	3.06	0	0.002		72.1	0.09	10.3	1017	
12/27/2007	1108	13.5	3.34	0	0.022		77.0	0.03	6.3	1017	
12/27/2007	1352	13.4	2.8	0	0.022		75.2		8.8	1016	
1/2/2008	1121	13.4	3.06	0	0.022		41.4	0.01	19.0	1012	

Tracer Test #1 (10 cfm to INJ2, ~7% H2)										
1/21/2008	1046 Test start									
1/21/2008	1208	20.9	0	0	0.002		76.5	0.02	10.0	1007
1/21/2008	1336	20.3	0.26	0	0.002		72.4		11.1	1006
1/22/2008	944	20.2	0.44	0	0.005		75.8	-0.02	6.8	1011
1/23/2008	1009	19.0	0.72	0	0.010		77.8	0.20	8.9	1007
1/23/2008	1156*	18.3		0						

Aerojet GEDIT - Injection Test Input

Phase II Piezometer Monitoring Data

Well ID P1

Depth 68

Note - slight flow restriction on P1-68 feet

Date	Time	Well or Injection Gas Sample						Well	Ambient Air
		O ₂ (%)	CO ₂ (%)	Propane (%)	H ₂ (%)	He (ppm)	RH (%)	Pressure (in wc)	Temperature (C°)

Tracer Test #2 (20 cfm to INJ2, ~8% H2)										
1/18/2008	1120 Test start									
1/18/2008	1503	19.0	0.44	0	0.010		57.7	0.02	17.7	1014
1/19/2008	928	20.4	0.46	0	0.002		59.8	0.02	7.2	1014
1/19/2008	1127*	18.2	0.98	0	0.001		46.3		16.3	1018

Tracer Test #3 (30 cfm to INJ2, ~4% H2)										
1/30/2008	1036 Test start									
1/30/2008	1134	19.0	0.90	0	0.010		80.7	0.02	10.2	1020
1/30/2008	1249	18.9	1.02	0	0.001		74.1		11.5	1019
1/30/2008	1455	18.4	1.28	0	0.002		66.3	0.08	15.1	1018
1/31/2008	1010	18.8	1.08	0	0.005		79.1	0.08	9.5	1019
1/31/2008	1148	18.4	1.12	0	0.005		79.1		9.6	1018
1/31/2008	1412	18.4	1.18	0	0.005		79.6	0.09	8.7	1016
1/31/2008	1435									
1/31/2008	1539	18.3	1.16	0	0.005		81.5	0.25	8.4	1014

Aerojet GEDIT - Injection Test Input

Phase II Piezometer Monitoring Data

Well ID P1

Depth 68

Note - slight flow restriction on P1-68 feet

Date	Time	Well or Injection Gas Sample						Well	Ambient Air
		O ₂ (%)	CO ₂ (%)	Propane (%)	H ₂ (%)	He (ppm)	RH (%)	Pressure (in wc)	Temperature (C°)

Tracer Test #4 (60 cfm to INJ2, ~7% H2)										
1/28/2008	1236 Test start									
1/28/2008	1401									
1/29/2008	825	20.3	0.02	0	0.005		79.9	0.04	5.0	1017
1/29/2008	Final O2*		20.3							

Tracer Test #5 (90 cfm to INJ2, ~3% H2)										
2/5/2008	1015 Test start									
2/5/2008	1156	18.7	0.62	0	0.005		79.1	0.04	11.2	1019
2/5/2008	1402	18.5	0.64	0	0.005		77.8	0.13	12.8	1018
2/5/2008	1524	19.0	0.68	0	0.000		43.4		22.5	1019
2/5/2008	1609	18.7	0.78	0	0.001		55.4		18.3	1018

Tracer Test #6 (30 cfm total; 10 cfm to each INJ1, 2, and 3; ~8% H2)										
2/7/2008	1500 Test start									
2/7/2008	1550	17.6	1.06	0	0.000		48.9		24.8	1016
2/7/2008	1638	17.6	1.06	0	0.005		53.1		20.5	1016
2/8/2008	1031	17.2	1.06	0	0.010		69.7		10.0	1017

Aerojet GEDIT - Injection Test Input

Phase II Piezometer Monitoring Data

Well ID P1

Depth 68

Note - slight flow restriction on P1-68 feet

Date	Time	Well or Injection Gas Sample						Well	Ambient Air
		O ₂ (%)	CO ₂ (%)	Propane (%)	H ₂ (%)	He (ppm)	RH (%)	Pressure (in wc)	Temperature (C°)
Tracer Test #7 (60 cfm total; 20 cfm to each INJ1, 2, and 3, ~5% H2)									
1/17/2008	900	Test start							
1/17/2008	1239	19.6	0.24	0	0.002		66.3	10.8	1014
Tracer Test #8 (90 cfm total; 30 cfm each to INJ1, 2, and 3; ~4.5% H2)									
2/6/2008	1000	Test start							
2/6/2008	1059	18.8	0.62	0	0.005		75.3	0.07	11.2
2/6/2008	1211	18.6	0.64	0	0.002		73.5		13.4
2/6/2008	1305	18.2	0.68	0	0.001		72.1		14.6
2/6/2008	1458	17.8	0.72	0	0.005		70.3	0.12	16.0
Optimization Test #1 (90 cfm to INJ2 for 4 hours then shut down; ~88% N2, 10% H2, 1% CO2 & LPG)									
2/20/2008	1128	16.6	1.78	0	0.01		68		15.2
2/20/2008	1206	Test start							
2/20/2008	1606	Test End							
2/20/2008	1620	16.0	1.56	0	0.005		45.1		22.4
2/21/2008	926	16.2	1.62	0	0.005		74		10.5
2/22/2008	1033	15.1	1.98	0	0.005		79.2		9.7

Aerojet GEDIT - Injection Test Input

Phase II Piezometer Monitoring Data

Well ID P1

Depth 68

Note - slight flow restriction on P1-68 feet

Date	Time	Well or Injection Gas Sample						Well	Ambient Air
		O ₂ (%)	CO ₂ (%)	Propane (%)	H ₂ (%)	He (ppm)	RH (%)	Pressure (in wc)	Temperature (C°)
Optimization Test #2 (30 cfm to INJ2 for 12 hours then shut down; ~88% N2, 10% H2, 1% CO2 & LPG)									
2/25/2008	1845 Test Start								
2/26/2008	653 Test End								
2/26/2008	732	15.1	2.48	0.08	0.005		86.1	4.3	1017
2/27/2008	1602	14.1	1.84	0	0.001		26.8	38.1	1009
2/28/2008	1049	14.2	1.88	0	0.005		71.4	15.7	1007
Optimization Test #3A (1 cfm to INJ2; ~88% N2, 10% H2, 1% CO2 & LPG)									
2/29/2008	1319 Test Start								
2/29/2008	1459	13.9	1.62	0	0.002		44.2	31.8	1009
3/3/2008	1041	14.7	1.64	0	0.001		56.3	14.9	1019
3/3/2008	1130 Test End								
Optimization Test #3B (1 cfm to INJ1, INJ2 & INJ3; ~88% N2, 10% H2, 1% CO2 & LPG)									
3/3/2008	1130 Test Start								
3/4/2008	953	14.3	1.78	0	0.002		56.4	14.2	1013
3/7/2008	1052	14.5	1.48	0	0.005		56.4	18.2	1018
3/7/2008	1306 Test End								

Aerojet GEDIT - Injection Test Input

Phase II Piezometer Monitoring Data

Well ID P1

Depth 68

Note - slight flow restriction on P1-68 feet

Date	Time	Well or Injection Gas Sample						Well	Ambient Air
		O ₂ (%)	CO ₂ (%)	Propane (%)	H ₂ (%)	He (ppm)	RH (%)	Pressure (in wc)	Temperature (C°)
Optimization Test #3C (90 cfm to INJ1, INJ2 & INJ3 for 15 minutes then shut down; ~79% N2, 10% H2 & LPG, 1% CO2)									
3/7/2008	1306 Start Pulse								
3/7/2008	1321 End Pulse								
Optimization Test #4 (2, 45-minutes pulses; daily 15-minutes pulses w/30cfh constant flow)									
Optimization Test #5 (20 cfm to INJ2 for 125 minutes while maintaing 30 cfh the rest of the time; ~80% N2, 10% H2 & LPG)									
Optimization Test #6 (50 cfh to P4-18 & P4-28; ~80% N2, 10% H2 & LPG)									
3/20/2008	1330 Start Test								
3/26/2008	1025	16.9	1.34	0	0.002		45.7	12.1	1017
3/28/2008	939	16.2	1.74	0	0.005		52.3	10.1	1009
3/31/2008	940	15.7	1.76	0	0.01		69.2	9.0	1013
4/2/2008	1105	15.5	1.72	0	0.005		56.2	16.2	1008
Optimization Test #7 (20 cfh to P4-18, --28, -38 (60 cfh total); ~80% N2, 10% H2 & LPG)									
4/2/2008	1233 Start Test								
4/4/2008	949	15.0	1.76	0	0.005		57.2	13.3	1013
4/7/2008	1417	14.8	2.02	0.0	0.005		60.4	19.5	1011

Aerojet GEDIT - Injection Test Input

Phase II Piezometer Monitoring Data

Well ID P1

Depth 68

Note - slight flow restriction on P1-68 feet

Date	Time	Well or Injection Gas Sample						Well	Ambient Air
		O ₂ (%)	CO ₂ (%)	Propane (%)	H ₂ (%)	He (ppm)	RH (%)	Pressure (in wc)	Temperature (C°)
Optimization Test #7B (30 cfh to P4-18, & P4-28 (60 cfh total); ~80% N2, 10% H2 & LPG)									
4/7/2008	1458	Start Test							
4/9/2008	1117		14.3	1.70	0.0	0.002	60.0	14.9	1009
Optimization Test #7C (50 cfh to P4-18, & P4-28 (100 cfh total); ~79% N2, 10% H2 & LPG, 1% CO2)									
4/10/2009	1121	Start Test							
4/11/2008	1242		14.3	1.86	0.0	0.005	49.5	22.6	1012
4/16/2008	1036		15.4	1.66	0.0	0.002	47.5	16.2	1011
4/22/2008	1025		15	1.84	0.0	0.005	52.1	17.7	1009
4/25/2008	1007		15	1.84	0.0	0.005	44.1	23.1	1015
4/29/2008	1117		14.3	1.86	0.0	0.005	52.6	24.0	1007
5/5/2008	1321		13.5	1.82	0.0	0.005	43.4	36.7	1001
5/13/2008	945		13.8	1.94	0.02	0.001	21.1	34.2	1007
5/20/2008	944		14.0	2.08	0.02	0.001	35.8	25.2	1004
5/23/2008	1529		13.4	1.80	0.02	0.005	26.8	29.3	990
5/27/2008	914		13.6	1.58	0.01	0.001	46.0	17.3	1007
6/4/2008	917		13.2	1.76	0.0	0.002	38.0	24.9	1002
6/12/2008	1209		12.9	1.98	0.0	0.002	21.7	42.9	1003
6/20/2008	1039		12.9	1.94	0.0	0.000	24.8	41.8	1005
6/25/2008	1056		12.9	1.98	0.0	0.005	33.7	33.7	1005

Aerojet GEDIT - Injection Test Input

Phase II Piezometer Monitoring Data

Well ID P1

Depth 68

Note - slight flow restriction on P1-68 feet

Date	Time	Well or Injection Gas Sample						Well	Ambient Air
		O ₂ (%)	CO ₂ (%)	Propane (%)	H ₂ (%)	He (ppm)	RH (%)	Pressure (in wc)	Temperature (C°)
7/2/2008	1158	12.8	1.98	0.0	0.005		64.2	30.4	1004
7/7/2008	1145	12.4	1.8	0	0.002		54.1	36.3	998
7/18/2008	1113	12.4	2.06	0.02	0.002		68.9	26.7	
7/24/2008	1028	12.4	2.06	0.0	0.005		53.7	26.7	1005
7/31/2008	1023	12.5	2.20	0.0	0.005		50.9	25.5	1003
8/7/2008	903	12.4	2.08	0.0	0.005		40.7	20.4	1004
8/12/2008	1006	12.3	2.00	0.02	0.002		44.4	28.1	1002
Optimization Test #8 (100 cfh of 100% Propane to P4-18, & P4-28 (50 cfh to each point)									
9/8/2008	0905 Test Start								
9/8/2008	Tubing to P1 cut at all points, will measure next visit								999
9/29/2008	Tubing to P1 cut again at all points,								
11/17/2008	1141	9.8	2.24	2.0	0.005		55.5	29.2	1014

Aerojet GEDIT - Injection Test Input

Phase II Piezometer Monitoring Data

Well ID P2

Depth 18

Date	Time	Well or Injection Gas Sample							Well	Ambient Air	
		O ₂ (%)	CO ₂ (%)	Propane (%)	H ₂ (%)	He (ppm)	RH (%)	Pressure (in wc)	Temperature (C°)	Barometric pressure (mbar)	
12/12/2007	1216	20.4	0.04	0	0.002	40,000	84.5	0.01	12.2	1020	
12/12/2007	1538							0.08			
12/13/2007	910	17.7	0	0	0.22		72.1		8.4	1016	
12/13/2007	948	17.1	0	0	0.22		71.8		11.3	1016	
12/13/2007	1046									1016	
12/13/2007	1200	Discovered leak in O2 - all O2 data for 12/13/07 before 1200 invalid									
12/13/2007	1319							0.07			
12/13/2007	1333	1.4	0.22	0	5.9		74.9		16.8	1013	
12/13/2007	1501	0.7	0.26	0	7.9		88.1		13.4	1013	
12/13/2007	1532	0.6	0.24	0	7.9		86.6		12.8	1013	
12/14/2007	838	1.4	0.24	0.18	3.2		72.0	0.02	6.5	1016	
12/21/2007	1143	19.2	0.38	0	0.22		83.2	0.04	9.9	1013	
12/26/2007	1146	19.4	0.3	0	0.022		85.1	0.04	10.6	1017	
12/27/2007	1000	19.8	0.34	0.02	0.22		73.7	0.02	6.1	1018	
12/27/2007	1257	18.9	0.26	0	0.22		81.7		9.2	1016	
12/27/2007	1429	18.8	0.24	0	0.46		86.6		8.4	1017	
12/27/2009	1545	18.7	0.26	0	0.46		88.8	0.03	7.5	1017	
1/2/2008	1018	10.6	0.38	0	0.022		61.8	0.03	17.7	1012	
1/21/2008	958 ¹	0.7	0.02	0	0.005		89.1		8.7	1007	
1/21/2008	1005 ²	1.6	0.02	0	0.010		85.1		8.4	1007	
1/21/2008	1010 ³	1.4	0.02	0	0.010		90.0		8.2		

Aerojet GEDIT - Injection Test Input

Phase II Piezometer Monitoring Data

Well ID P2

Depth 18

Date	Time	Well or Injection Gas Sample							Well	Ambient Air
		O ₂ (%)	CO ₂ (%)	Propane (%)	H ₂ (%)	He (ppm)	RH (%)	Pressure (in wc)	Temperature (C°)	Barometric pressure (mbar)
Tracer Test #1 (10 cfm to INJ2, ~7% H2)										
1/21/2008	1046									
1/21/2008	1147	2.2	0.04	0	0.010		80.1	0.04	9.7	1008
1/21/2008	1304	1.3	0.04	0	0.046		73.6		10.1	1006
1/21/2008	1458	1.7	0.04	0	0.010		77.1	0.02	10.7	1006
1/21/2008	1619	1.7	0.04	0	0.046		77.8		10.8	1006
1/22/2008	1039	1.5	0.12	0	0.76		83.3	0.06	6.4	1011
1/22/2008	1329	1.3	0.08	0	1.0		90.9		7.5	1009
1/23/2008	1044	2.1	0.1	0	2.4		96.3	0.04	7.6	1008
1/23/2008	1157*	1.4								
Tracer Test #2 (20 cfm to INJ2, ~8% H2)										
1/18/2008	1120									
1/18/2008	1149	1.4	0.04	0	0.022		96.5		13.1	1015
1/18/2008	1243	1.3	0.06	0	0.046		93.8	0.02	13.8	1014
1/18/2008	1332	1.5	0.06	0	0.046		90.0		15.3	1014
1/18/2008	1507	1.5	0.04	0	0.046		75.8	0.04	18.3	1014
1/19/2008	932	1.7	0.18	0	4.0		88.4	0.04	8.4	1019
1/19/2008	1113*	1.0	0.14		4.8		60.7		19.1	1018

Aerojet GEDIT - Injection Test Input

Phase II Piezometer Monitoring Data

Well ID P2

Depth 18

Date	Time	Well or Injection Gas Sample							Well	Ambient Air
		O ₂ (%)	CO ₂ (%)	Propane (%)	H ₂ (%)	He (ppm)	RH (%)	Pressure (in wc)	Temperature (C°)	Barometric pressure (mbar)

Tracer Test #3 (30 cfm to INJ2, ~4% H2)											
1/30/2008	1036	Test start									
1/30/2008	1137	0.0	0	0	0.10		93.1	0.06	10.2	1020	
1/30/2008	1255	0.0	0	0	0.046		92.9		12.0	1019	
1/30/2008	1501	0.0	0	0	0.046		82.6	0.04	15.3	1018	
1/31/2008	1017	0.0	0	0	4.0		87.2	0.07	9.3	1019	
1/31/2008	1151	0	0	0	3.7		83.3		9.6	1018	
1/31/2008	1423	0	0	0	3.7		86.5	0.08	8.3	1015	
1/31/2008	1435										
1/31/2008	1545	0	0	0	3.6		84.1	0.06	8.3	1014	
1/31/2008	1612	0	0	0	3.6		85.4		8.3	1014	

Tracer Test #4 (60 cfm to INJ2, ~7% H2)											
1/28/2008	1236	Test start									
1/28/2008	1314	12.8	0.12	0	0.010		96.6		10.3	1010	
1/28/2008	1445	8.0	0.10	0	0.22		92.1	0.08	12.8	1011	
1/28/2008	1618	3.4	0.06	0	2.1		86.0	0.06	9.6	1012	
1/29/2008	847	0	0.08	0	7.2		92.2	0.06	5.0	1017	
1/29/2008	Final O2*	0									

Aerojet GEDIT - Injection Test Input

Phase II Piezometer Monitoring Data

Well ID P2

Depth 18

Date	Time	Well or Injection Gas Sample							Well	Ambient Air	
		O ₂ (%)	CO ₂ (%)	Propane (%)	H ₂ (%)	He (ppm)	RH (%)	Pressure (in wc)	Temperature (C°)	Barometric pressure (mbar)	
Tracer Test #5 (90 cfm to INJ2, ~3% H2)											
2/5/2008	1015	Test start									
2/5/2008	1056	1.2	0	0	0.022		94.0	0.10	10.8	1019	
2/5/2008	1200	0.5	0	0	0.46		93.2		11.2	1019	
2/5/2008	1407	0.1	0	0	2.7		91.2	0.10	12.7	1018	
2/5/2008	1527	0.1	0	0	3.0		56.7		19.4	1019	
2/5/2008	1611	0	0	0	3.1		64.9		11.4	1018	
Tracer Test #6 (30 cfm total; 10 cfm to each INJ1, 2, and 3; ~8% H2)											
2/7/2008	1500	Test start									
2/7/2008	1509	0.0	0	0	0.022		60.7		20.5	1016	
2/7/2008	1600	0.0	0	0	0.10		41.8		28.1	1016	
2/8/2008	927	0.0	0	0	9.0		88.3		8.7	1017	
Tracer Test #7 (60 cfm total; 20 cfm to each INJ1, 2, and 3, ~5% H2)											
1/17/2008	900	Test start									
1/17/2008	941	13.2	0.24	0	0.86		97.8	0.00	6.0	1015	
1/17/2008	1123	1.8	0.16	0	4.7		93.8	0.04	10.1	1015	
1/17/2008	1310	1.4	0.24	0	5.3		89.4	0.02	12.2	1013	
1/17/2008	1440	1.3	0.18	0	5.6		87.8		13.1	1013	
1/17/2008	1602	1.2	0.16	0	5.9		63.0		17.7	10121	
1/17/2008	1608	0.6*	Measured directly from piezometer with no tubing.								

Aerojet GEDIT - Injection Test Input

Phase II Piezometer Monitoring Data

Well ID P2

Depth 18

Date	Time	Well or Injection Gas Sample							Well	Ambient Air	
		O ₂ (%)	CO ₂ (%)	Propane (%)	H ₂ (%)	He (ppm)	RH (%)	Pressure (in wc)	Temperature (C°)	Barometric pressure (mbar)	
Tracer Test #8 (90 cfm total; 30 cfm each to INJ1, 2, and 3; ~4.5% H2)											
2/6/2008	1000	Test start									
2/6/2008	1008		2.7	0.02	0	0.022		93.8	0.14	10.5	1020
2/6/2008	1112		0.0	0	0	3.9		85.7		12.0	1020
2/6/2008	1215		0.0	0	0	4.2		86.6		13.5	1019
2/6/2008	1405		0.0	0	0	4.8		84.5	0.16	15.5	1017
2/6/2008	1516		0.0	0.00	0	5.6		69.0		17.5	1017
Optimization Test #1 (90 cfm to INJ2 for 4 hours then shut down; ~88% N2, 10% H2, 1% CO2 & LPG)											
2/20/2008	1151		15.4	0.10	0	0.022		66.7		15.4	1010
2/20/2008	1206	Test start									
2/20/2008	1523		2.8	0	0.68	7.3		42.1		28.3	1007
2/20/2008	1606	Test End									
2/20/2008	1646		3.0	0	0.72	6.1		56		21	1008
2/21/2008	941		12.6	0.06	0.06	2.8		74.1		10.5	1005
2/22/2008	1102		15.2	0.12	0.04	0.77		79.2		10.3	1003
Optimization Test #2 (30 cfm to INJ2 for 12 hours then shut down; ~88% N2, 10% H2, 1% CO2 & LPG)											
2/25/2008	1845	Test Start									
2/26/2008	653	Test End									
2/26/2008	735		6.8	0.2	0.52	2.2		86.1		4.6	1017
2/27/2008	1605		13.5	0.08	0.04	0.5		32		35.7	1009
2/28/2008	1116		14.4	0.04	0.04	0.046		85.5		16.9	1007

Aerojet GEDIT - Injection Test Input

Phase II Piezometer Monitoring Data Well ID P2 Depth 18

Date	Time	Well or Injection Gas Sample							Well	Ambient Air
		O ₂ (%)	CO ₂ (%)	Propane (%)	H ₂ (%)	He (ppm)	RH (%)	Pressure (in wc)	Temperature (C°)	Barometric pressure (mbar)
Optimization Test #3A (1 cfm to INJ2; ~88% N2, 10% H2, 1% CO2 & LPG)										
2/29/2008	1319									
2/29/2008	1503	14.6	0.02	0.06	0.005		41.6		30.7	1009
3/3/2008	1109	16.8	0.1	0	0.002		61.5		16.2	1019
3/3/2008	1130									
Optimization Test #3B (1 cfm to INJ1, INJ2 & INJ3; ~88% N2, 10% H2, 1% CO2 & LPG)										
3/3/2008	1130									
3/4/2008	955	15.5	0.1	0.02	0.88		64.1		14.3	1013
3/7/2008	1124	8.9	0	0.46	2.2		65.5		19.8	1018
3/7/2008	1306									
Optimization Test #3C (90 cfm to INJ1, INJ2 & INJ3 for 15 minutes then shut down; ~79% N2, 10% H2 & LPG, 1% CO2)										
3/7/2008	1306									
3/7/2008	1321									
3/7/2008	1351	5.1	0	0.6	3		61.7		23.4	1016
3/10/2008	1112	14.4	0.06	0.16	0.01		78.2		17.2	1016
Optimization Test #4 (2, 45-minutes pulses; daily 15-minutes pulses w/30cfh constant flow)										
3/10/2008	1242	14.1	0.12	0.32	0.022		67.9		21.1	1016
Optimization Test #5 (20 cfm to INJ2 for 125 minutes while maintaing 30 cfh the rest of the time; ~80% N2, 10% H2 & LPG)										

Aerojet GEDIT - Injection Test Input

Phase II Piezometer Monitoring Data

Well ID P2

Depth 18

Date	Time	Well or Injection Gas Sample							Well	Ambient Air
		O ₂ (%)	CO ₂ (%)	Propane (%)	H ₂ (%)	He (ppm)	RH (%)	Pressure (in wc)	Temperature (C°)	Barometric pressure (mbar)
Optimization Test #6 (50 cfh to P4-18 & P4-28; ~80% N2, 10% H2 & LPG)										
3/20/2008	1330	Start Test								
3/21/2008	957	15.2	0.20	0.30	0.010		72.3		11.6	1020
3/24/2008	1017	10.9	0.20	0.90	0.022					
3/26/2008	1032	10.9	0.16	0.80	0.022		68.9		12.4	1017
3/28/2008	959	9.8	0.16	0.86	0.022		52.8		10.7	1009
3/31/2008	1003	3.6	0.08	4.5	2.5		71.9		10.3	1013
4/2/2008	1108	3.5	0.08	6.0	2.7		66.9		16.4	1008
Optimization Test #7 (20 cfh to P4-18, --28, -38 (60 cfh total); ~80% N2, 10% H2 & LPG)										
4/2/2008	1233	Start Test								
4/4/2008	952	2.3	0.02	9.0	2.6		57.6		13.5	1013
4/7/2008	1420	5.9	0.06	6.0	0.94		67.7		19.4	1011
Optimization Test #7B (30 cfh to P4-18, & P4-28 (60 cfh total); ~80% N2, 10% H2 & LPG)										
4/7/2008	1458	Start Test								
4/9/2008	1123	8.2	0.00	4.0	0.46		85.2		14.8	1009

Aerojet GEDIT - Injection Test Input

Phase II Piezometer Monitoring Data

Well ID P2

Depth 18

Date	Time	Well or Injection Gas Sample							Well	Ambient Air
		O ₂ (%)	CO ₂ (%)	Propane (%)	H ₂ (%)	He (ppm)	RH (%)	Pressure (in wc)	Temperature (C°)	Barometric pressure (mbar)
Optimization Test #7C (50 cfh to P4-18, & P4-28 (100 cfh total); ~79% N2, 10% H2 & LPG, 1% CO2)										
4/10/2009	1121	Start Test								
4/11/2008	1245	11.2	0.02	2.5	0.1		69.3		22.5	1012
4/14/2008	1016	8.5	0.04	4.0	0.046		73.7		15.6	1007
4/16/2008	1038	4.2	0.00	6.5	2.4		55.8		16.4	1011
4/22/2008	1011	4.5	0.10	3.0	0.88		87.1		16.6	1009
4/23/2008	925	4.1	0.08	3.5	0.67		63.8		13	1010
4/25/2008	1009	4.4	0.14	4.5	0.010		50.2		23.2	1015
4/29/2008	1119	1.2	0.10	7.5	1.4		61.5		24.1	1007
5/5/2008	1322	2.3	0.02	7.0	1.3		48.1		36.9	1001
5/13/2008	947	0.8	0.08	8.5	0.63		38.1		34.5	1007
5/20/2008	945	4.2	0.12	5.5	0.10		56.3		24.8	1004
5/23/2008	1531	10.3	0.18	3.5	0.010		63.7		29.4	990
5/27/2008	916	4.4	0.22	7.0	0.64		69.8		17.6	1007
6/4/2008	919	0.3	0.32	9.5	1.8		55.1		24.7	1002
6/12/2008	1213	5.8	0.40	6.0	0.005		36.3		43.1	1003
6/20/2008	1042	0.2	0.32	8.0	1.200		38.6		42.2	1005
6/25/2008	1058	1.5	0.30	7.0	0.82		46.0		34.2	1005
7/2/2008	1200	0.8	0.4	7.5	1.0		72.6		30.8	1004
7/7/2008	1148	0.1	0.46	8.5	1.5		52.6		36.5	998
7/18/2008	1115	0.4	0.58	8	0.94		83.1		26.7	
7/24/2008	1030	0.5	0.62	7.5	1.100		76.6		26.9	1005
7/31/2008	1025	0.2	0.74	8.0	1.300		73.0		25.6	1003
8/7/2008	904	0.1	0.82	8.5	1.3		73.4		20.5	1004
8/12/2008	1008	0.1	0.78	7.5	1.2		51.1		28.3	1002

Aerojet GEDIT - Injection Test Input

Phase II Piezometer Monitoring Data

Well ID P2

Depth 18

Date	Time	Well or Injection Gas Sample							Well	Ambient Air
		O ₂ (%)	CO ₂ (%)	Propane (%)	H ₂ (%)	He (ppm)	RH (%)	Pressure (in wc)	Temperature (C°)	Barometric pressure (mbar)
Optimization Test #8 (100 cfh of 100% Propane to P4-18, & P4-28 (50 cfh to each point))										
9/8/2008	0905 Test Start									
9/8/2008	1053	7.2	1.32	2.5	0.005					999
9/15/2008	935	5.7	0.58	30	0.005		58.7	27.2		1007
9/29/2008	954	4.1	0.48	30	0.005		68.1	23.3		1006
10/13/2008	1212	13.2	3.22	4.5	0.005		29.9	32.2		1017
10/20/2008	1137	12.1	3.92	3.0	0.005		48.3	26.9		1013
11/5/2008	1327	10.2	5.00*	2.5	0.005		76.7	19.2		1016
11/17/2008	1124	6.9	5.00*	3.5	0.010		69.2	27.2		1014
12/1/2008	1056	7.0	5.00*	3.0	0.002		63.8	20.6		1014

Aerojet GEDIT - Injection Test Input

Phase II Piezometer Monitoring Data

Well ID P2

Depth 28

Date	Time	Well or Injection Gas Sample							Well	Ambient Air	
		O ₂ (%)	CO ₂ (%)	Propane (%)	H ₂ (%)	He (ppm)	RH (%)	Pressure (in wc)	Temperature (C°)	Barometric pressure (mbar)	
12/12/2007	1218	19.9	0.24	0	0.002	50,000	84.9	0.02	12.1	1020	
12/12/2007	1539							0.15			
12/13/2007	912	14.7	0	0	0.22		67.1		9.3	1016	
12/13/2007	950	14.3	0	0	0.22		73.2		11.2	1016	
12/13/2007	1200	Discovered leak in O2 - all O2 data for 12/13/07 before 1200 invalid									
12/13/2007	1319							0.11			
12/13/2007	1334	0.7	0.22	0	7.5		68.9		17.1	1013	
12/13/2007	1503	0.5	0.18	0	8.8		87.2		13.2	1013	
12/13/2007	1532	0.4	0.18	0.14	6.9		88.2		12.8	1013	
12/14/2007	839	0	0.24	0.26	1.8		66.8	0.03	6.7	1016	
12/21/2007	1147	18.3	0.48	0	0.46		88.8	0.04	9.5	1013	
12/26/2007	1149	19	0.44	0	0.002		86.6	0.01	10.4	1017	
12/27/2007	1003	17.6	0.46	0	0.5		74.8	0.04	6.5	1018	
12/27/2007	1258	16.9	0.36	0	0.46		82.2		9.5	1016	
12/27/2007	1431	16.6	0.36	0	0.77		88.6		8.3	1017	
12/27/2007	1547	16.4	0.36	0	0.98		90.1	0.03	7.5	1016	
1/2/2008	1021	4.6	0.56	0	0.22		57.5	0.02	17.3	1012	

1/21/2008	1000 ¹	0.6	0.06	0	0.022		90.0		8.6	1007
1/21/2008	1006 ²	1.4	0.06	0	0.022		80.0		8.4	1007
1/21/2008	1014 ³	1.3	0.06	0	0.010		90.1		8.0	

Aerojet GEDIT - Injection Test Input

Phase II Piezometer Monitoring Data

Well ID P2

Depth 28

Date	Time	Well or Injection Gas Sample							Well	Ambient Air
		O ₂ (%)	CO ₂ (%)	Propane (%)	H ₂ (%)	He (ppm)	RH (%)	Pressure (in wc)	Temperature (C°)	Barometric pressure (mbar)

Tracer Test #1 (10 cfm to INJ2, ~7% H2)										
1/21/2008	1046 Test start									
1/21/2008	1149	1.7	0.08	0	0.022		80.2	0.04	9.6	1008
1/21/2008	1306	1.6	0.06	0	0.046		72.6		9.9	1006
1/21/2008	1500	1.7	0.08	0	0.046		77.7	0.04	10.1	1006
1/21/2008	1620	1.7	0.06	0	0.046		77.5		10.0	1006
1/22/2008	1040	1.4	0.14	0	2.3		80.8	0.06	6.5	1011
1/22/2008	1330	1.2	0.10	0	2.8		86.8		7.9	1009
1/23/2008	1043	1.7	0.14	0	4.3		97.5	0.00	7.6	1008
1/23/2008	1158*	1.0								

Tracer Test #2 (20 cfm to INJ2, ~8% H2)										
1/18/2008	1120 Test start									
1/18/2008	1151	1.4	0.10	0	0.046		96.7		13.1	1015
1/18/2008	1244	1.3	0.10	0	0.046		95.7	0.01	13.9	1014
1/18/2008	1333	1.5	0.12	0	0.046		91.2		15.2	1014
1/18/2008	1509	1.5	0.12	0	0.010		80.4	0.03	18.0	1014
1/19/2008	933	1.4	0.24	0	7.9		81.5	0.03	9.5	1019
1/19/2008	1114*	0.7	0.20	0	8.7		65.4		19.5	1018

Aerojet GEDIT - Injection Test Input

Phase II Piezometer Monitoring Data

Well ID P2

Depth 28

Date	Time	Well or Injection Gas Sample							Well	Ambient Air
		O ₂ (%)	CO ₂ (%)	Propane (%)	H ₂ (%)	He (ppm)	RH (%)	Pressure (in wc)	Temperature (C°)	Barometric pressure (mbar)

Tracer Test #3 (30 cfm to INJ2, ~4% H2)										
1/30/2008	1036									
1/30/2008	1139	0.0	0	0	0.10		93.0	0.07	10.1	1020
1/30/2008	1256	0.0	0	0	0.046		94.7		12.1	1019
1/30/2008	1502	0.0	0	0	0.59		84.1	0.09	15.2	1018
1/31/2008	1018	0.0	0	0	4.1		84.5	0.08	9.2	1019
1/31/2008	1154	0	0	0	3.9		85.1		9.5	1018
1/31/2008	1424	0	0	0	3.9		83.7	0.13	8.3	1015
1/31/2008	1435									
1/31/2008	1546	0	0	0	3.8		81.5	0.05	8.2	1014
1/31/2008	1613	0	0	0	3.9		83.1		8.2	1013

Tracer Test #4 (60 cfm to INJ2, ~7% H2)										
1/28/2008	1236									
1/28/2008	1316	7.9	0.12	0	0.010		97.8		10.3	1010
1/28/2008	1446	4.5	0.12	0	0.75		92.2	0.12	12.9	1011
1/28/2008	1619	1.4	0.10	0	3.7		86.6	0.07	9.5	1012
1/29/2008	848	0	0.06	0	7.2		88.8	0.05	5.6	1017
1/29/2008	Final O2*	0								

Aerojet GEDIT - Injection Test Input

Phase II Piezometer Monitoring Data

Well ID P2

Depth 28

Date	Time	Well or Injection Gas Sample							Well	Ambient Air
		O ₂ (%)	CO ₂ (%)	Propane (%)	H ₂ (%)	He (ppm)	RH (%)	Pressure (in wc)	Temperature (C°)	Barometric pressure (mbar)
Tracer Test #5 (90 cfm to INJ2, ~3% H2)										
2/5/2008	1015									
2/5/2008	1058	0.9	0	0	0.022		96.6	0.17	10.8	1019
2/5/2008	1201	0.3	0	0	1.1		94.7		11.3	1019
2/5/2008	1408	0.0	0	0	3.2		89.9	0.18	12.7	1018
2/5/2008	1528	0.0	0	0	3.2		59.0		18.2	1019
2/5/2008	1612	0.0	0	0	3.3		63.5		11.3	1018
Tracer Test #6 (30 cfm total; 10 cfm to each INJ1, 2, and 3; ~8% H2)										
2/7/2008	1500									
2/7/2008	1510	0.0	0	0	0.022		54.3		21.4	1016
2/7/2008	1601	0.0	0	0	0.10		40.5		27.4	1016
2/8/2008	928	0.0	0	0	9.0		85.4		8.8	1017
Tracer Test #7 (60 cfm total; 20 cfm to each INJ1, 2, and 3, ~5% H2)										
1/17/2008	900									
1/17/2008	942	15.8	0.28	0	0.46		98.0	0.03	6.2	1015
1/17/2008	1125	4.6	0.18	0	3.9		94.8	0.02	10.1	1015
1/17/2008	1313	1.5	0.3	0	5.2		92.6	0.01	12.0	1013
1/17/2008	1443	1.2	0.26	0	5.7		89.4		13.0	1012
1/17/2008	1603	1.1	0.22	0	6.0		69.1		16.6	1012

Aerojet GEDIT - Injection Test Input

Phase II Piezometer Monitoring Data

Well ID P2

Depth 28

Date	Time	Well or Injection Gas Sample							Well	Ambient Air
		O ₂ (%)	CO ₂ (%)	Propane (%)	H ₂ (%)	He (ppm)	RH (%)	Pressure (in wc)	Temperature (C°)	Barometric pressure (mbar)

Tracer Test #8 (90 cfm total; 30 cfm each to INJ1, 2, and 3; ~4.5% H2)											
2/6/2008	1000	Test start									
2/6/2008	1010	2.5	0.04	0	0.046		94.7	0.26	10.6	1020	
2/6/2008	1113	0.0	0	0	2.0		92.5		12.0	1020	
2/6/2008	1216	0.0	0	0	3.9		91.8		13.54	1019	
2/6/2008	1406	0.0	0	0	4.8		86.3	0.26	15.5	1017	
2/6/2008	1517	0.0	0	0	4.5		72.1		17.4	1017	

Optimization Test #1 (90 cfm to INJ2 for 4 hours then shut down; ~88% N2, 10% H2, 1% CO2 & LPG)											
2/20/2008	1152	12.8	0.00	0	0.046		66.4		15.2	1010	
2/20/2008	1206	Test start									
2/20/2008	1524	1.6	0	0.86	9.3		45.6		27.2	1007	
2/20/2008	1606	Test End									
2/20/2008	1647	2.4	0	0.78	9		56.7		20.9	1008	
2/21/2008	943	4.0	0.00	0.62	5.1		73.9		10.5	1005	
2/22/2008	1103	12	0.00	0.26	1.3		78.2		10.3	1003	

Optimization Test #2 (30 cfm to INJ2 for 12 hours then shut down; ~88% N2, 10% H2, 1% CO2 & LPG)											
2/25/2008	1845	Test Start									
2/26/2008	653	Test End									
2/26/2008	737	4.5	0.14	0.54	4.8		84.3		8.7	1017	
2/27/2008	1606	8.8	0	0.28	1.1		33.8		34.2	1009	
2/28/2008	1116	12.4	0	0.18	0.1		81.9		16.7	1007	

Aerojet GEDIT - Injection Test Input

Phase II Piezometer Monitoring Data

Well ID P2

Depth 28

Date	Time	Well or Injection Gas Sample							Well	Ambient Air
		O ₂ (%)	CO ₂ (%)	Propane (%)	H ₂ (%)	He (ppm)	RH (%)	Pressure (in wc)	Temperature (C°)	Barometric pressure (mbar)
Optimization Test #3A (1 cfm to INJ2; ~88% N2, 10% H2, 1% CO2 & LPG)										
2/29/2008	1319 Test Start									
2/29/2008	1503	13.9	0	0.14	0.022		44.5	29.5	1009	
3/3/2008	1110	15.8	0.04	0.04	0.002		58.7	16.2	1019	
3/3/2008	1130 Test End									
Optimization Test #3B (1 cfm to INJ1, INJ2 & INJ3; ~88% N2, 10% H2, 1% CO2 & LPG)										
3/3/2008	1130 Test Start									
3/4/2008	956	14	0.06	0.16	0.59		63.3	14.4	1013	
3/7/2008	1129	14.1	0	0.14	1		64.7	19.8	1018	
3/7/2008	1306 Test End									
Optimization Test #3C (90 cfm to INJ1, INJ2 & INJ3 for 15 minutes then shut down; ~79% N2, 10% H2 & LPG, 1% CO2)										
3/7/2008	1306 Start Pulse									
3/7/2008	1321 End Pulse									
3/7/2008	1352	12.4	0	0.22	1.6		59.5	23.4	1016	
3/10/2008	1113	15.9	0.06	0.12	0.1		72.2	17.2	1016	
Optimization Test #4 (2, 45-minutes pulses; daily 15-minutes pulses w/30cfh constant flow)										
3/10/2008	1243	16	0.14	0.16	0.046		72.3	21.1	1016	
Optimization Test #5 (20 cfm to INJ2 for 125 minutes while maintaing 30 cfh the rest of the time; ~80% N2, 10% H2 & LPG)										

Aerojet GEDIT - Injection Test Input

Phase II Piezometer Monitoring Data

Well ID P2

Depth 28

Date	Time	Well or Injection Gas Sample							Well	Ambient Air
		O ₂ (%)	CO ₂ (%)	Propane (%)	H ₂ (%)	He (ppm)	RH (%)	Pressure (in wc)	Temperature (C°)	Barometric pressure (mbar)
Optimization Test #6 (50 cfh to P4-18 & P4-28; ~80% N2, 10% H2 & LPG)										
3/20/2008	1330 Start Test									
3/21/2008	959	11.7	0.18	1.50	0.046		73.2		11.4	1020
3/24/2008	1018	10.3	0.26	1.32	0.046		61.6		16.0	1012
3/26/2008	1033	7.9	0.24	1.40	0.046		73.5		12.4	1017
3/28/2008	1000	7.8	0.26	1.34	0.046		57.0		10.7	1009
3/31/2008	1004	2.2	0.22	9.0	4.0		73.4		10.3	1013
4/2/2008	1109	1.1	0.2	12.5	3.9		75.5		16.5	1008
Optimization Test #7 (20 cfh to P4-18, --28, -38 (60 cfh total); ~80% N2, 10% H2 & LPG)										
4/2/2008	1233 Start Test									
4/4/2008	953	2.1	0.18	10.5	2.7		58.3		13.6	1013
4/7/2008	1421	3.9	0.22	8.5	0.95		67.6		19.4	1011
Optimization Test #7B (30 cfh to P4-18, & P4-28 (60 cfh total); ~80% N2, 10% H2 & LPG)										
4/7/2008	1458 Start Test									
4/9/2008	1124	7.1	0.14	6.0	0.1		88.0		14.8	1009

Aerojet GEDIT - Injection Test Input

Phase II Piezometer Monitoring Data

Well ID P2

Depth 28

Date	Time	Well or Injection Gas Sample							Well	Ambient Air	
		O ₂ (%)	CO ₂ (%)	Propane (%)	H ₂ (%)	He (ppm)	RH (%)	Pressure (in wc)	Temperature (C°)	Barometric pressure (mbar)	
Optimization Test #7C (50 cfh to P4-18, & P4-28 (100 cfh total); ~79% N2, 10% H2 & LPG, 1% CO2)											
4/10/2009	1121	Start Test									
4/11/2008	1246	10.2	0.22	4.0	0.1		63.6	22.4	1012		
4/14/2008	1017	7.3	0.24	5.5	0.8		67.7	15.5	1007		
4/16/2008	1039	2.6	0.26	9.0	2.6		60.3	16.6	1011		
4/22/2008	1012	10.4	0.28	1.4	0.22		78.2	16.7	1009		
4/23/2008	926	7.4	0.28	2.5	0.22		61.7	12.9	1010		
4/25/2008	1011	3.6	0.36	6.5	0.046		52.7	23.7	1015		
4/29/2008	1120	1.0	0.30	8.0	1.2		64.5	24.4	1007		
5/5/2008	1324	5.7	0.26	4.5	0.61		45.8	37.0	1001		
5/13/2008	948	1.4	0.30	8.5	0.10		37.7	34.7	1007		
5/20/2008	946	4.4	0.40	6.0	0.046		55.6	24.0	1004		
5/23/2008	1532	17.8	0.48	0.9	0.010		56.8	29.0	990		
5/27/2008	918	9.4	0.58	3.5	0.80		70.5	17.8	1007		
6/4/2008	920	2.4	0.48	7.5	0.95		57.0	24.6	1002		
6/12/2008	1214	7.1	0.62	5.0	0.046		31.5	43.1	1003		
6/20/2008	1043	1.0	0.48	8.0	0.870		32.7	42.7	1005		
6/25/2008	1059	1.3	0.42	8.0	0.51		45.8	33.3	1005		
7/2/2008	1201	1.0	0.42	8.0	0.50		67.2	30.9	1004		
7/7/2008	1149	0.7	0.38	8	0.63		46.7	36.5	998		
7/18/2008	1116	0.3	0.48	8.5	0.6		71.9	26.7			
7/24/2008	1031	0.6	0.56	8.5	0.540		68.4	27.0	1005		
7/31/2008	1027	0.4	0.64	8.5	0.680		60.0	25.7	1003		
8/7/2008	905	0.2	0.68	8.5	0.83		72.1	20.6	1004		
8/12/2008	1015	0.2	0.68	8.5	0.65		52.5	28.5	1002		

Aerojet GEDIT - Injection Test Input

Phase II Piezometer Monitoring Data

Well ID P2

Depth 28

Date	Time	Well or Injection Gas Sample							Well	Ambient Air
		O ₂ (%)	CO ₂ (%)	Propane (%)	H ₂ (%)	He (ppm)	RH (%)	Pressure (in wc)	Temperature (C°)	Barometric pressure (mbar)
Optimization Test #8 (100 cfh of 100% Propane to P4-18, & P4-28 (50 cfh to each point))										
9/8/2008	0905 Test Start									
9/8/2008	1055	4.4	1.18	5.5	0.005					999
9/15/2008	936	7.5	0.42	30	0.005		58.6	27.3		1007
9/29/2008	955	3.1	0.16	30	0.005		68.9	23.5		1006
10/13/2008	1213	10.7	1.02	30	0.005		32.2	31.0		1017
10/20/2008	1139	8.5	1.00	30	0.005		49.2	27.0		1013
11/5/2008	1329	8.9	1.04	30	0.005		79.3	19.2		1016
11/17/2008	1125	6.7	1.02	30	0.010		70.4	27.0		1014
12/1/2008	1057	6.8	1.08	30	0.002		64.7	20.6		1014

Aerojet GEDIT - Injection Test Input

Phase II Piezometer Monitoring Data

Well ID P2

Depth 38

Date	Time	Well or Injection Gas Sample							Well	Ambient Air	
		O ₂ (%)	CO ₂ (%)	Propane (%)	H ₂ (%)	He (ppm)	RH (%)	Pressure (in wc)	Temperature (C°)	Barometric pressure (mbar)	
12/12/2007	1220	19.4	0.38	0	0.002	70,000	85.8	0.02	12.1	1020	
12/12/2007	1538							0.20			
12/13/2007	913	19.8	0.12	0	0.022		62.9		10.4	1016	
12/13/2007	953	19.6	0.06	0	0.22		75.1		11.1	1016	
12/13/2007	1200	Discovered leak in O2 - all O2 data for 12/13/07 before 1200 invalid									
12/13/2007	1319							0.12			
12/13/2007	1336	15.1	0.54	0	0.22		69.6		16.8	1013	
12/13/2007	1503	12.2	0.54	0	1.6		90.9		13.1	1013	
12/13/2007	1533	11.1	0.56	0	2.2		88.6		12.7	1013	
12/14/2007	841	5.8	0.62	0.02	2.7		67.3	0.01	7.1	1016	
12/21/2007	1149	14.0	0.72	0.04	0.46		89.5	0.03	9.4	1013	
12/26/2007	1151	16.2	0.64	0.02	0.022		88.3	0.04	10.3	1017	
12/27/2007	1005	16.8	0.64	0	0.22		76.4	0.03	6.3	1018	
12/27/2007	1300	17.2	0.46	0	0.22		80.2		9.4	1016	
12/27/2007	1433	17.1	0.46	0	0.22		89.5		8.2	1017	
12/27/2007	1549	17.2	0.44	0	0.22		90.1	0.01	7.5	1016	
1/2/2008	1022	12.3	0.72	0	0.22		61.2	0.02	17.4	1012	
1/21/2008	1001 ¹	1.2	0.38	0	0.10		88.8		8.5	1007	
1/21/2008	1007 ²	1.8	0.36	0	0.22		83.0		8.4	1007	
1/21/2008	1016 ³	1.8	0.36	0	0.046		89.6		8.0		

Aerojet GEDIT - Injection Test Input

Phase II Piezometer Monitoring Data

Well ID P2

Depth 38

Date	Time	Well or Injection Gas Sample							Well	Ambient Air
		O ₂ (%)	CO ₂ (%)	Propane (%)	H ₂ (%)	He (ppm)	RH (%)	Pressure (in wc)	Temperature (C°)	Barometric pressure (mbar)
Tracer Test #1 (10 cfm to INJ2, ~7% H2)										
1/21/2008	1046	Test start								
1/21/2008	1150	2.1	0.34	0	0.046		79.2	0.06	9.6	1007
1/21/2008	1307	2.1	0.38	0	0.046		74.2		9.7	1006
1/21/2008	1501	2.2	0.36	0	0.046		78.8	0.02	10.7	1006
1/21/2008	1622	2.4	0.38	0	0.046		78.8		10.0	1006
1/22/2008	1041	2.3	0.48	0	0.22		79.8	0.06	6.5	1011
1/22/2008	1335	2.1	0.44	0	0.50		85.4		7.6	1009
1/23/2008	1048	2.3	0.48	0	1.3		97.8	0.02	7.4	1008
1/23/2008	1159*	1.7								
Tracer Test #2 (20 cfm to INJ2, ~8% H2)										
1/18/2008	1120	Test start								
1/18/2008	1152	1.6	0.38	0	0.46		96.9		13.1	1015
1/18/2008	1245	1.5	0.42	0	0.57		96.1	0.02	13.9	1014
1/18/2008	1334	1.8	0.42	0	0.66		92.0		15.1	1014
1/18/2008	1510	1.9	0.40	0	0.61		83.4	0.03	17.9	1014
1/19/2008	934	2.4	0.66	0	2.1		73.2	0.01	7.1	1019
1/19/2008	1117*	1.7	0.58	0	2.4		47.0		19.5	1018

Aerojet GEDIT - Injection Test Input

Phase II Piezometer Monitoring Data

Well ID P2

Depth 38

Date	Time	Well or Injection Gas Sample							Well	Ambient Air
		O ₂ (%)	CO ₂ (%)	Propane (%)	H ₂ (%)	He (ppm)	RH (%)	Pressure (in wc)	Temperature (C°)	Barometric pressure (mbar)

Tracer Test #3 (30 cfm to INJ2, ~4% H2)											
1/30/2008	1036	Test start									
1/30/2008	1140	0.0	0.34	0	0.80		91.4	0.09	10.0	1020	
1/30/2008	1257	0.1	0.32	0	0.68		95.0		12.1	1019	
1/30/2008	1503	0.1	0.32	0	0.75		85.8	0.09	15.1	1018	
1/31/2008	1019	0.0	0.38	0	2.9		82.3	0.11	9.1	1019	
1/31/2008	1155	0	0.40	0	2.8		81.8		9.4	1018	
1/31/2008	1425	0	0.40	0	2.9		81.4	0.13	8.3	1015	
1/31/2008	1435										
1/31/2008	1547	0	0.38	0	2.9		74.6	0.03	8.2	1014	

Tracer Test #4 (60 cfm to INJ2, ~7% H2)											
1/28/2008	1236	Test start									
1/28/2008	1317	2.7	0.52	0	0.046		98.2		10.3	1010	
1/28/2008	1447	2.7	0.54	0	0.046		92.8	0.16	12.9	1011	
1/28/2008	1620	2.6	0.52	0	0.50		86.2	0.12	9.4	1012	
1/29/2008	849	0.3	0.54	0	6.3		88.2	0.08	4.9	1017	
1/29/2008	Final O2*	0.3									

Aerojet GEDIT - Injection Test Input

Phase II Piezometer Monitoring Data

Well ID P2

Depth 38

Date	Time	Well or Injection Gas Sample							Well	Ambient Air
		O ₂ (%)	CO ₂ (%)	Propane (%)	H ₂ (%)	He (ppm)	RH (%)	Pressure (in wc)	Temperature (C°)	Barometric pressure (mbar)
Tracer Test #5 (90 cfm to INJ2, ~3% H2)										
2/5/2008	1015	Test start								
2/5/2008	1059	1.3	0.22	0	0.010		91.1	0.20	10.5	1019
2/5/2008	1202	1.3	0.22	0	0.022		94.9		11.3	1019
2/5/2008	1409	1.3	0.22	0	0.22		89.1	0.21	12.7	1018
2/5/2008	1529	1.2	0.28	0	0.64		60.2		17.5	1019
2/5/2008	1612	1.1	0.26	0	0.77		62.5		11.1	1018
Tracer Test #6 (30 cfm total; 10 cfm to each INJ1, 2, and 3; ~8% H2)										
2/7/2008	1500	Test start								
2/7/2008	1511	0.0	0.18	0	0.046		58.6		11.4	1016
2/7/2008	1602	0.0	0.16	0	0.10		43.8		26.7	1016
2/8/2008	930	0.0	0.16	0	7.5		78.9		9.5	1017
2/8/2008	1044	0.0	0.14	0	7.0		90.4		10.3	1017
Tracer Test #7 (60 cfm total; 20 cfm to each INJ1, 2, and 3, ~5% H2)										
1/17/2008	900	Test start								
1/17/2008	943	15.1	0.52	0	0.22		97.7	0.04	6.5	1015
1/17/2008	1126	14.7	0.44	0	1.1		95.0	0.04	10.1	1015
1/17/2008	1314	4.4	0.66	0	3.8		93.2		11.9	1014
1/17/2008	1444	2.5	0.66	0	4.8		91.3	0.02	12.9	1012
1/17/2008	1605	1.8	0.62	0	5.4		73.7		15.7	1012

Aerojet GEDIT - Injection Test Input

Phase II Piezometer Monitoring Data

Well ID P2

Depth 38

Date	Time	Well or Injection Gas Sample							Well	Ambient Air
		O ₂ (%)	CO ₂ (%)	Propane (%)	H ₂ (%)	He (ppm)	RH (%)	Pressure (in wc)	Temperature (C°)	Barometric pressure (mbar)
Tracer Test #8 (90 cfm total; 30 cfm each to INJ1, 2, and 3; ~4.5% H2)										
2/6/2008	1000	Test start								
2/6/2008	1011	2.8	0.24	0	0.10		91.8	0.26	10.8	1020
2/6/2008	1115	0.0	0.18	0	0.10		93.3		12.0	1020
2/6/2008	1223	0.0	0.16	0	2.1		86.9		13.2	1019
2/6/2008	1407	0.0	0.16	0	4.0		87.8	0.25	15.5	1017
2/6/2008	1517	0.0	0.12	0	4.0		71.4		17.1	1017
2/6/2008	1608	0.0	0.22	0	3.9		58.0		19.1	1017
Optimization Test #1 (90 cfm to INJ2 for 4 hours then shut down; ~88% N2, 10% H2, 1% CO2 & LPG)										
2/20/2008	1154	4.6	0.22	0	0.046		70.7		15.1	1010
2/20/2008	1206	Test start								
2/20/2008	1525	4.2	0.18	0	0.87		47.5		26	1007
2/20/2008	1606	Test End								
2/20/2008	1648	4.0	0.16	0.04	2		56.6		20.9	1008
2/21/2008	944	3.5	0.16	0.18	2.4		74.4		10.5	1005
2/22/2008	1104	4.5	0.14	0.1	0.78		77.7		10.3	1003
Optimization Test #2 (30 cfm to INJ2 for 12 hours then shut down; ~88% N2, 10% H2, 1% CO2 & LPG)										
2/25/2008	1845	Test Start								
2/26/2008	653	Test End								
2/26/2008	738	6.4	0.3	0.22	1		82.7		4.8	1017
2/27/2008	1607	6.4	0.1	0.1	0.1		37.6		32.5	1009
2/28/2008	1118	7.5	0.08	0.08	0.046		84.4		16.7	1007

Aerojet GEDIT - Injection Test Input

Phase II Piezometer Monitoring Data

Well ID P2

Depth 38

Date	Time	Well or Injection Gas Sample							Well	Ambient Air
		O ₂ (%)	CO ₂ (%)	Propane (%)	H ₂ (%)	He (ppm)	RH (%)	Pressure (in wc)	Temperature (C°)	Barometric pressure (mbar)
Optimization Test #3A (1 cfm to INJ2; ~88% N2, 10% H2, 1% CO2 & LPG)										
2/29/2008	1319									
2/29/2008	1504	8.3	0.06	0.1	0.01		46.4	28.6	1009	
3/3/2008	1111	10.3	0.12	0.04	0.002		59.6	16.2	1019	
3/3/2008	1130									
Optimization Test #3B (1 cfm to INJ1, INJ2 & INJ3; ~88% N2, 10% H2, 1% CO2 & LPG)										
3/3/2008	1130									
3/4/2008	958	10.8	0.12	0.06	0.022		65.2	14.4	1013	
3/7/2008	1127	12	0.08	0.04	0.022		63.6	19.8	1018	
3/7/2008	1306									
Optimization Test #3C (90 cfm to INJ1, INJ2 & INJ3 for 15 minutes then shut down; ~79% N2, 10% H2 & LPG, 1% CO2)										
3/7/2008	1306									
3/7/2008	1321									
3/7/2008	1353	11.7	0.08	0.04	0.022		60.5	23.4	1016	
3/10/2008	1114	12.3	0.12	0.06	0.022		71.4	17.1	1016	
Optimization Test #4 (2, 45-minutes pulses; daily 15-minutes pulses w/30cfh constant flow)										
Optimization Test #5 (20 cfm to INJ2 for 125 minutes while maintaing 30 cfh the rest of the time; ~80% N2, 10% H2 & LPG)										

Aerojet GEDIT - Injection Test Input

Phase II Piezometer Monitoring Data

Well ID P2

Depth 38

Date	Time	Well or Injection Gas Sample							Well	Ambient Air
		O ₂ (%)	CO ₂ (%)	Propane (%)	H ₂ (%)	He (ppm)	RH (%)	Pressure (in wc)	Temperature (C°)	Barometric pressure (mbar)
Optimization Test #6 (50 cfh to P4-18 & P4-28; ~80% N2, 10% H2 & LPG)										
3/20/2008	1330	Start Test								
3/21/2008	1001	11.5	0.20	1.38	0.010		75.0		11.6	1020
3/24/2008	1019	12.0	0.24	1.26	0.022		61.2		16.1	1012
3/26/2008	1034	12.1	0.22	1.04	0.010		76.1		12.4	1017
3/28/2008	1001	12.3	0.26	0.82	0.022		58.3		10.6	1009
3/31/2008	1005	6.5	0.14	5.5	1.0		72.8		10.4	1013
4/2/2008	1110	5.2	0.08	7.5	0.22		73.8		16.6	1008
Optimization Test #7 (20 cfh to P4-18, --28, -38 (60 cfh total); ~80% N2, 10% H2 & LPG)										
4/2/2008	1233	Start Test								
4/4/2008	953	4.5	0.06	8.0	0.1		58.3		13.6	1013
4/7/2008	1423	4.5	0.18	9.0	0.01		69.2		19.5	1011
Optimization Test #7B (30 cfh to P4-18, & P4-28 (60 cfh total); ~80% N2, 10% H2 & LPG)										
4/7/2008	1458	Start Test								
4/9/2008	1126	5.3	0.12	8.5	0.022		90.7		14.7	1009

Aerojet GEDIT - Injection Test Input

Phase II Piezometer Monitoring Data

Well ID P2

Depth 38

Date	Time	Well or Injection Gas Sample							Well	Ambient Air
		O ₂ (%)	CO ₂ (%)	Propane (%)	H ₂ (%)	He (ppm)	RH (%)	Pressure (in wc)	Temperature (C°)	Barometric pressure (mbar)
Optimization Test #7C (50 cfh to P4-18, & P4-28 (100 cfh total); ~79% N2, 10% H2 & LPG, 1% CO2)										
4/10/2009	1121	Start Test								
4/11/2008	1247	6.2	0.20	8.0	0.1			65.9	22.4	1012
4/14/2008	1018	4.2	0.16	9.5	0.6			74.7	15.5	1007
4/16/2008	1040	3.5	0.14	10.0	0.1			55.9	16.7	1011
4/22/2008	1013	6.1	0.30	3.5	0.022			84.1	16.7	1009
4/23/2008	927	5.1	0.30	4.0	0.010			61.1	12.9	1010
4/25/2008	1012	2.6	0.32	6.5	0.022			52.4	23.8	1015
4/29/2008	1121	3.1	0.34	6.5	0.22			63.3	24.8	1007
5/5/2008	1325	4.7	0.34	5.5	0.1			47.1	37.3	1001
5/13/2008	949	2.8	0.40	7.0	0.046			38.1	35.1	1007
5/20/2008	947	2.6	0.46	7.5	0.046			58.9	23.5	1004
5/23/2008	1535	4.0	0.44	7.0	0.046			53.9	29.0	990
5/27/2008	919	5.3	0.60	6.5	0.046			71.1	18.0	1007
6/4/2008	921	4.9	0.50	6.0	0.046			58.2	24.9	1002
6/12/2008	1216	3.5	0.58	6.5	0.022			29.8	43.4	1003
6/20/2008	1044	3.4	0.60	6.5	0.046			30.7	42.6	1005
6/25/2008	1100	3.1	0.62	6.5	0.046			45.8	32.7	1005
7/2/2008	1203	2.6	0.68	6.5	0.046			59.6	31.1	1004
7/7/2008	1150	2.3	0.66	7.0	0.046			44.1	36.4	998
7/18/2008	1117	1.3	0.88	7.0	0.046			69.6	26.7	
7/24/2008	1032	1.1	0.96	7.0	0.100			63.2	27.0	1005
7/31/2008	1028	0.8	1.14	7.0	0.100			58.1	25.8	1003
8/7/2008	906	0.5	1.20	7.5	0.50			70.2	20.6	1004
8/12/2008	1010	0.4	1.18	7.5	0.10			47.0	28.5	1002

Aerojet GEDIT - Injection Test Input

Phase II Piezometer Monitoring Data

Well ID P2

Depth 38

Date	Time	Well or Injection Gas Sample							Well	Ambient Air
		O ₂ (%)	CO ₂ (%)	Propane (%)	H ₂ (%)	He (ppm)	RH (%)	Pressure (in wc)	Temperature (C°)	Barometric pressure (mbar)
Optimization Test #8 (100 cfh of 100% Propane to P4-18, & P4-28 (50 cfh to each point))										
9/8/2008	0905	Test Start								
9/8/2008	1056		0.4	1.28	12.0	0.005				999
9/15/2008	938		0.6	0.8	30	0.010		57.7	27.3	1007
9/29/2008	956		0.0	0.40	30	0.010		66.9	23.8	1006
10/13/2008	1214		0.8	0.56	30	0.005		36.6	30.2	1017
10/20/2008	1140		0.4	0.64	30	0.005		51.2	26.7	1013
11/5/2008	1330		0.2	0.64	30	0.005		80.1	19.1	1016
11/17/2008	1126		0.1	0.58	30	0.005		73.2	26.7	1014
12/1/2008	1058		0.0	0.60	30	0.002		66.7	20.5	1014

Aerojet GEDIT - Injection Test Input

Phase II Piezometer Monitoring Data

Well ID P2

Depth 48

Date	Time	Well or Injection Gas Sample						Well	Ambient Air		
		O ₂ (%)	CO ₂ (%)	Propane (%)	H ₂ (%)	He (ppm)	RH (%)	Pressure (in wc)	Temperature (C°)	Barometric pressure (mbar)	
12/12/2007	1222	18.0	0.52	0	0.002	100,000	86.5	0.01	12.0	1020	
12/12/2007	1538							0.19			
12/13/2007	916	20.4	0	0	0.022		57.8		11.4	1016	
12/13/2007	955	20.1	0	0	0.22		73.7		10.9	1016	
12/13/2007	1200	Discovered leak in O2 - all O2 data for 12/13/07 before 1200 invalid									
12/13/2007	1319							0.13			
12/13/2007	1337	17.7	0.6	0	0.22		67.5		16.5	1013	
12/13/2007	1505	17.2	0.6	0	0.22		88.8		13.0	1013	
12/13/2007	1535	16.4	0.56	0	0.46		85.6		12.5	1013	
12/14/2007	842	16.0	0.60	0	0.50		66.1	0.0	7.2	1016	
12/21/2007	1151	16.2	1.38	0	0.22		90.0	0.02	9.5	1013	
12/26/2007	1153	16.3	1.32	0	0.022		88.1	0.03	10.5	1017	
12/27/2007	1007	16.5	1.48	0	0.22		78.6	0.04	5.8	1018	
12/27/2007	1302	16.3	1.26	0	0.022		80.7		9.1	1016	
12/27/2007	1435	16.3	1.2	0	0.022		88.5		8.2	1017	
12/27/2007	1551	16.5	1.26	0	0.022		90.3	0.03	7.5	1017	
1/2/2008	1025	16.5	1.66	0	0.022		55.8	0.03	18.2	1012	
1/21/2008	1002 ¹	16.2	1.18	0	0.010		90.3		8.4	1007	
1/21/2008	1008 ²	16.2	1.20	0	0.02		82.6		8.4	1007	
1/21/2008	1019 ³	16.2	1.22	0	0.02		89.9		8.0		

Aerojet GEDIT - Injection Test Input

Phase II Piezometer Monitoring Data

Well ID P2

Depth 48

Date	Time	Well or Injection Gas Sample						Well	Ambient Air
		O ₂ (%)	CO ₂ (%)	Propane (%)	H ₂ (%)	He (ppm)	RH (%)	Pressure (in wc)	Temperature (C°)

Tracer Test #1 (10 cfm to INJ2, ~7% H2)										
1/21/2008	1046 Test start									
1/21/2008	1151	15.2	1.18	0	0.022		81.3	0.03	9.6	1007
1/21/2008	1308	15.0	1.16	0	0.010		75.2		9.5	1006
1/21/2008	1502	14.9	1.14	0	0.022		78.9	0.04	10.7	1006
1/21/2008	1623	15.1	1.18	0	0.022		78.1		10.0	1006
1/22/2008	1043	14.8	1.34	0	0.022		80.3	0.02	6.6	1011
1/22/2008	1336	14.4	1.24	0	0.022		86.1		7.7	1009
1/23/2008	1049	14.3	1.18	0	0.10		97.6	0.01	7.3	1008
1/23/2008	1200*	14.3								

Tracer Test #2 (20 cfm to INJ2, ~8% H2)										
1/18/2008	1120 Test start									
1/18/2008	1153	15.4	1.16	0	0.022		96.6		13.0	1015
1/18/2008	1246	15.3	1.20	0	0.022		96.1	0.02	13.9	1014
1/18/2008	1335	15.6	1.20	0	0.022		91.0		15.0	1014
1/18/2008	1511	15.7	1.20	0	0.046		82.9	0.03	17.8	1014
1/19/2008	936	15.4	1.52	0	0.022		72.1	0.00	11.4	1019
1/19/2008	1118*	15.0	1.44	0	0.022		52.4		19.3	1018

Aerojet GEDIT - Injection Test Input

Phase II Piezometer Monitoring Data

Well ID P2

Depth 48

Date	Time	Well or Injection Gas Sample						Well	Ambient Air
		O ₂ (%)	CO ₂ (%)	Propane (%)	H ₂ (%)	He (ppm)	RH (%)	Pressure (in wc)	Temperature (C°)

Tracer Test #3 (30 cfm to INJ2, ~4% H2)										
1/30/2008	1036 Test start									
1/30/2008	1141	13.0	0.42	0	0.010		92.3	0.06	9.8	1020
1/30/2008	1258	13.0	0.40	0	0.022		93.9		12.0	1019
1/30/2008	1504	16.7	0.36	0	0.010		85.4	0.05	15.1	1018
1/31/2008	1021	18.1	0.40	0	0.010		92.4	0.06	9.1	1019
1/31/2008	1156	20.2	0.36	0	0.010		91.1		9.4	1018
1/31/2008	1426	20.9	0.34	0	0.010		89.5	0.08	8.3	1015
1/31/2008	1435									
1/31/2008	1548	20.9	0.30	0	0.010		87.4	0.04	8.2	1014

Tracer Test #4 (60 cfm to INJ2, ~7% H2)										
1/28/2008	1236 Test start									
1/28/2008	1318	20.3	0	0	0.010		96.1		10.3	1010
1/28/2008	1448							0.06		
1/28/2008	1623									
1/29/2008	850	14.4	0.36	0	0.022		91.5	-0.16	5.6	1017
1/29/2008	Final O2*	14.4								

Aerojet GEDIT - Injection Test Input

Phase II Piezometer Monitoring Data

Well ID P2

Depth 48

Date	Time	Well or Injection Gas Sample						Well	Ambient Air
		O ₂ (%)	CO ₂ (%)	Propane (%)	H ₂ (%)	He (ppm)	RH (%)	Pressure (in wc)	Temperature (C°)

Tracer Test #5 (90 cfm to INJ2, ~3% H2)										
2/5/2008	1015 Test start									
2/5/2008	1104	18.6	0.38	0	0.005		94.0	0.02	10.6	1019
2/5/2008	1203	18.7	0.38	0	0.010		94.2		11.3	1019
2/5/2008	1410	18.6	0.38	0	0.022		91.5	0.04	12.7	1018
2/5/2008	1531	18.8	0.42	0	0.005		70.6		16.4	1019
2/5/2008	1613	18.4	0.40	0	0.010		68.8		18.8	1018

Tracer Test #6 (30 cfm total; 10 cfm to each INJ1, 2, and 3; ~8% H2)										
2/7/2008	1500 Test start									
2/7/2008	1512	15.4	0.54	0	0.005		67.8		21.4	1016
2/7/2008	1603	15.1	0.52	0	0.010		51.4		26.3	1016
2/8/2008	932	13.2	0.56	0	0.010		81.8		10.0	1017
2/8/2008	1045	12.8	0.54	0	0.010		92.6		10.4	1017

Aerojet GEDIT - Injection Test Input

Phase II Piezometer Monitoring Data

Well ID P2

Depth 48

Date	Time	Well or Injection Gas Sample						Well	Ambient Air
		O ₂ (%)	CO ₂ (%)	Propane (%)	H ₂ (%)	He (ppm)	RH (%)	Pressure (in wc)	Temperature (C°)

Tracer Test #7 (60 cfm total; 20 cfm to each INJ1, 2, and 3; ~5% H2)										
1/17/2008	900	Test start								
1/17/2008	945	16.4	1.10	0	0.022		97.5	0.02	6.6	1015
1/17/2008	1127	16.3	0.94	0	0.22		95.6	0.02	10.2	1015
1/17/2008	1316	16.7	1.50	0	0.022		96.0	0.01	11.8	1013
1/17/2008	1446	16.7	1.48	0	0.22		91.8		12.8	1012
1/17/2008	1607	16.6	1.48	0	0.22		77.7		14.9	1012

Tracer Test #8 (90 cfm total; 30 cfm each to INJ1, 2, and 3; ~4.5% H2)										
2/6/2008	1000	Test start								
2/6/2008	1013	17.3	0.40	0	0.010		93.4	0.06	11.0	1020
2/6/2008	1116	16.6	0.40	0	0.010		92.0		12.0	1020
2/6/2008	1225	16.2	0.38	0	0.002		95.0		13.3	1019
2/6/2008	1409	15.9	0.36	0	0.022		90.7	0.04	15.7	1017
2/6/2008	1519	15.7	0.36	0	0.022		78.1		16.9	1017
2/6/2008	1610	15.8	0.46	0	0.010		65.4		18.4	1017

Aerojet GEDIT - Injection Test Input

Phase II Piezometer Monitoring Data

Well ID P2

Depth 48

Date	Time	Well or Injection Gas Sample						Well	Ambient Air
		O ₂ (%)	CO ₂ (%)	Propane (%)	H ₂ (%)	He (ppm)	RH (%)	Pressure (in wc)	Temperature (C°)
Optimization Test #1 (90 cfm to INJ2 for 4 hours then shut down; ~88% N2, 10% H2, 1% CO2 & LPG)									
2/20/2008	1155	14.8	0.14	0	0.1		68.8	15	1010
2/20/2008	1206 Test start								
2/20/2008	1527	4.5	0.12	0.3	0.022		49.3	25.1	1007
2/20/2008	1606 Test End								
2/20/2008	1649	2.8	0.1	0.36	2.9		57.2	21	1008
2/21/2008	949	4.5	0.14	0.1	0.1		85.9	10.6	1005
2/22/2008	1105	5.6	0.30	0.14	0.022		78.6	10.3	1003
Optimization Test #2 (30 cfm to INJ2 for 12 hours then shut down; ~88% N2, 10% H2, 1% CO2 & LPG)									
2/25/2008	1845 Test Start								
2/26/2008	653 Test End								
2/26/2008	740	7.9	0.3	0.14	0.005		83.1	4.9	1017
2/27/2008	1608	6.4	0.2	0.08	0.01		40.9	30.8	1009
2/28/2008	1119	6.5	0.2	0.02	0.022		85.8	16.7	1007
Optimization Test #3A (1 cfm to INJ2; ~88% N2, 10% H2, 1% CO2 & LPG)									
2/29/2008	1319 Test Start								
2/29/2008	1505	6.2	0.16	0.02	0.005		52.3	27.4	1009
3/3/2008	1112	20.4	0.2	0	0.001		63.7	16.2	1019
3/3/2008	1130 Test End								

Aerojet GEDIT - Injection Test Input

Phase II Piezometer Monitoring Data

Well ID P2

Depth 48

Date	Time	Well or Injection Gas Sample						Well	Ambient Air
		O ₂ (%)	CO ₂ (%)	Propane (%)	H ₂ (%)	He (ppm)	RH (%)	Pressure (in wc)	Temperature (C°)
Optimization Test #3B (1 cfm to INJ1, INJ2 & INJ3; ~88% N2, 10% H2, 1% CO2 & LPG)									
3/3/2008	1130 Test Start								
3/4/2008	959	20.4	0.22	0	0.005		72.7	14.5	1013
3/7/2008	1128	19.9	0.16	0	0.022		69.5	19.9	1018
3/7/2008	1306 Test End								
Optimization Test #3C (90 cfm to INJ1, INJ2 & INJ3 for 15 minutes then shut down; ~79% N2, 10% H2 & LPG, 1% CO2)									
3/7/2008	1306 Start Pulse								
3/7/2008	1321 End Pulse								
3/7/2008	1354	19.5	0.14	0	0.01		61.8	23.2	1016
3/10/2008	1115	19.9	0.22	0	0.022		73.5	17.2	1016
Optimization Test #4 (2, 45-minutes pulses; daily 15-minutes pulses w/30cfh constant flow)									
Optimization Test #5 (20 cfm to INJ2 for 125 minutes while maintaing 30 cfh the rest of the time; ~80% N2, 10% H2 & LPG)									

Aerojet GEDIT - Injection Test Input

Phase II Piezometer Monitoring Data

Well ID P2

Depth 48

Date	Time	Well or Injection Gas Sample						Well	Ambient Air
		O ₂ (%)	CO ₂ (%)	Propane (%)	H ₂ (%)	He (ppm)	RH (%)	Pressure (in wc)	Temperature (C°)
Optimization Test #6 (50 cfh to P4-18 & P4-28; ~80% N2, 10% H2 & LPG)									
3/20/2008	1330 Start Test								
3/24/2008	1020	17.4	0.54	0	0.010		16.7	16.1	1012
3/26/2008	1035	17.6	0.50	0	0.010		80.3	12.4	1017
3/28/2008	1002	18.6	0.52	0	0.005		60.5	10.6	1009
3/31/2008	1006	16.9	0.50	0	0.022		73.5	10.5	1013
4/2/2008	1112	9.8	0.70	1.66	0.022		75.3	16.7	1008
Optimization Test #7 (20 cfh to P4-18, --28, -38 (60 cfh total); ~80% N2, 10% H2 & LPG)									
4/2/2008	1233 Start Test								
4/4/2008	954	6.7	0.84	3.0	0.022		66.1	13.6	1013
4/7/2008	1425	4.1	1.24	3.0	0.1		74.5	19.4	1011
Optimization Test #7B (30 cfh to P4-18, & P4-28 (60 cfh total); ~80% N2, 10% H2 & LPG)									
4/7/2008	1458 Start Test								
4/9/2008	1127	4.8	1.26	2.5	0.005		95.2	15.1	1009

Aerojet GEDIT - Injection Test Input

Phase II Piezometer Monitoring Data

Well ID P2

Depth 48

Date	Time	Well or Injection Gas Sample						Well	Ambient Air
		O ₂ (%)	CO ₂ (%)	Propane (%)	H ₂ (%)	He (ppm)	RH (%)	Pressure (in wc)	Temperature (C°)
Optimization Test #7C (50 cfh to P4-18, & P4-28 (100 cfh total); ~79% N ₂ , 10% H ₂ & LPG, 1% CO ₂)									
4/10/2009	1121								
4/11/2008	1248	3.4	1.56	3.0	0.046		73.1	22.5	1012
4/14/2008	1020	3.1	1.64	4.5	0.046		74.2	15.4	1007
4/16/2008	1041	0.7	1.64	10.5	0.046		62.6	16.8	1011
4/22/2008	1015	0.0	1.50	2.5	0.046		72.2	16.8	1009
4/23/2008	928	0.0	1.76	3.0	0.046		63.1	12.9	1010
4/25/2008	1013	0.0	1.86	6.0	0.046		61.2	23.9	1015
4/29/2008	1122	0.0	1.78	5.5	0.22		67.8	25.1	1007
5/5/2008	1326	0.0	1.74	5.5	0.046		58.5	37.7	1001
5/13/2008	950	0.0	2.06	6.0	0.046		44.3	35.1	1007
5/20/2008	949	0.0	2.26	6.0	0.046		61.3	23.1	1004
5/23/2008	1536	0.0	2.00	6.0	0.022		55.6	29.0	990
5/27/2008	920	0.0	2.56	6.5	0.046		67.2	18.1	1007
6/4/2008	922	0.0	2.50	6.0	0.046		59.0	25.3	1002
6/12/2008	1217	0.0	2.56	5.5	0.022		30.5	43.2	1003
6/20/2008	1046	0.0	2.46	5.5	0.046		32.0	42.1	1005
6/25/2008	1101	0.0	2.56	5.5	0.046		46.1	32.1	1005
7/2/2008	1204	0.0	2.70	5.5	0.046		58.6	31.4	1004
7/7/2008	1151	0.0	2.5	5.5	0.046		44.4	36.3	998

Aerojet GEDIT - Injection Test Input

Phase II Piezometer Monitoring Data

Well ID P2

Depth 48

Date	Time	Well or Injection Gas Sample						Well	Ambient Air
		O ₂ (%)	CO ₂ (%)	Propane (%)	H ₂ (%)	He (ppm)	RH (%)	Pressure (in wc)	Temperature (C°)
7/18/2008	1118	0.0	2.78	5.5	0.046		73.7	26.7	
7/24/2008	1033	0.0	2.84	5.5	0.100		69.7	27.1	1005
7/31/2008	1029	0.0	2.94	5.5	0.100		59.0	25.9	1003
8/7/2008	907	0.0	1.48	6.5	0.50		65.2	20.6	1004
8/12/2008	1011	0.0	2.72	6.5	0.10		47.2	28.6	1002
Optimization Test #8 (100 cfh of 100% Propane to P4-18, & P4-28 (50 cfh to each point)									
9/8/2008	0905 Test Start								
9/8/2008	1058	0.0	2.02	20	0.005				999
9/15/2008	939	0.0	1.66	30	0.010		57.6	27.2	1007
9/29/2008	956	0.0	1.52	30	0.010		63.5	24.0	1006
10/13/2008	1215	0.0	1.26	30	0.005		40.9	29.1	1017
10/20/2008	1141	0.0	1.26	30	0.005		56.8	26.7	1013
11/5/2008	1331	0.0	1.16	30	0.005		79.3	19.1	1016
11/17/2008	1127	0.0	1.04	30	0.005		71.6	26.6	1014
12/1/2008	1059	0.0	1.04	30	0.002		66.5	20.6	1014

Aerojet GEDIT - Injection Test Input

Phase II Piezometer Monitoring Data

Well ID P3

Depth 18

Date	Time	Well or Injection Gas Sample							Well	Ambient Air	
		O ₂ (%)	CO ₂ (%)	Propane (%)	H ₂ (%)	He (ppm)	RH (%)	Pressure (in wc)	Temperature (C°)	Barometric pressure (mbar)	
12/12/2007	1227	19.6	0.00	0	0.002	40,000	78.3	0.03	12.5	1020	
12/12/2007	1535							0.17			
12/13/2007	854	15.6	0	0	0.22		84.3		5.7	1016	
12/13/2007	942	16.5	0	0	0.22		69.1		11.6	1016	
12/13/2007	1200	Discovered leak in O2 - all O2 data for 12/13/07 before 1200 invalid									
12/13/2007	1320							0.14			
12/13/2007	1330	7.7	0	0	4.3		66.4		17.0	1014	
12/13/2007	1450	6.0	0	0	5.9		86.0		19.0	1013	
12/13/2007	1525	4.7	0	0	5.8		76.3		14.1	1013	
12/14/2007	819	4.6	0	0.16	2.1		79.3	0.04	4.2	1016	
12/21/2007	1128	10.7	0.16	0.08	0.46		75.7	0.04	11.0	1013	
12/26/2007	1200	15	0.24	0.04	0.22		85.5	0	11.3	1017	
12/26/2007	1505	15.3	0.14	0.04	0.22		85.7		10.5	1015	
12/26/2007	1553	15.6	0.16	0.04	0.22		80.8	0.02	10.6	1015	
12/27/2007	943	8.4	0.08	0.04	4.5		80.2	0.05	5.2	1017	
12/27/2007	1248	1.8	0.12	0	7.5		74.4		9.2	1017	
12/27/2007	1417	1.6	0.1	0	8.1		82.7		8.9	1017	
12/27/2007	1538	1.5	0.1	0	8.4		83.9	0.04	7.6	1017	
1/2/2008	956	2.2	0.18	0	0.022		48.6	0.04	15.5	1012	

Aerojet GEDIT - Injection Test Input

Phase II Piezometer Monitoring Data

Well ID P3

Depth 18

Date	Time	Well or Injection Gas Sample						Well	Ambient Air
		O ₂ (%)	CO ₂ (%)	Propane (%)	H ₂ (%)	He (ppm)	RH (%)	Pressure (in wc)	Temperature (C°)

Tracer Test #1 (10 cfm to INJ2, ~7% H2)										
1/21/2008	1046	Test start								
1/21/2008	1115	2.1	0.06	0	1.3		83.6	0.08	8.2	1008
1/21/2008	1257	1.8	0	0	0.98		77.6		10.6	1006
1/21/2008	1451	1.8	0	0	0.88		78.3	0.08	10.8	1006
1/21/2008	1618	1.8	0	0	0.94		79.9	0.05	10.0	1006
1/22/2008	1045	1.6	0.06	0	4.4		86.2	0.09	6.7	1011
1/22/2008	1337	1.4	0	0	4.6		87.9		7.9	1009
1/23/2008	1050	1.5	0.04	0	5.1		97.7	0.05	7.3	1008
1/23/2008	1202*	1.1								

Tracer Test #2 (20 cfm to INJ2, ~8% H2)										
1/18/2008	1120	Test start								
1/18/2008	1137	1.5	0.02	0	0.10		81.0		12.6	1015
1/18/2008	1236	1.7	0.04	0	0.10		73.4	0.03	13.7	1014
1/18/2008	1327	1.7	0	0	0.046		74.2		15.5	1014
1/18/2008	1512	2.0	0	0	0.50		65.6	0.03	17.6	1014
1/19/2008	939	2.3	0.12	0	7.3		68.3	0.01	12.6	1019
1/19/2008	1103*	1.8	0.04	0	7.9		56.4		16.4	1019

Aerojet GEDIT - Injection Test Input

Phase II Piezometer Monitoring Data

Well ID P3

Depth 18

Date	Time	Well or Injection Gas Sample						Well	Ambient Air
		O ₂ (%)	CO ₂ (%)	Propane (%)	H ₂ (%)	He (ppm)	RH (%)	Pressure (in wc)	Temperature (C°)

Tracer Test #3 (30 cfm to INJ2, ~4% H2)										
1/30/2008	1036	Test start								
1/30/2008	1145	0.0	0	0	0.10		91.6	0.11	9.8	1020
1/30/2008	1303	0.0	0	0	0.046		94.2		11.9	1019
1/30/2008	1509	0.1	0	0	0.84		81.8	0.10	14.7	1018
1/31/2008	1023	0.1	0	0	3.3		88.6	0.20	9.1	1019
1/31/2008	1157	0.1	0	0	3.2		89.1		9.3	1018
1/31/2008	1418	0	0	0	3.2		84.0	0.19	8.5	1016
1/31/2008	1435									
1/31/2008	1549	0.1	0	0	3.1		86.2	0.07	8.2	1014

Tracer Test #4 (60 cfm to INJ2, ~7% H2)										
1/28/2008	1236	Test start								
1/28/2008	1308	2.3	0.04	0	0.022		95.4		10.7	1010
1/28/2008	1438	0.9	0.08	0	2.7		76.4	0.10	13.0	1011
1/28/2008	1623	0.9	0.04	0	2.9		88.0	0.16	9.3	1012
1/29/2008	838	0.3	0.04	0	6.0		88.1	0.15	5.1	1017
1/29/2008	Final O2*	0.3								

Aerojet GEDIT - Injection Test Input

Phase II Piezometer Monitoring Data

Well ID P3

Depth 18

Date	Time	Well or Injection Gas Sample						Well	Ambient Air	
		O ₂ (%)	CO ₂ (%)	Propane (%)	H ₂ (%)	He (ppm)	RH (%)	Pressure (in wc)	Temperature (C°)	Barometric pressure (mbar)
Tracer Test #5 (90 cfm to INJ2, ~3% H2)										
2/5/2008	1015	Test start								
2/5/2008	1105	0.4	0	0	0.10		95.4	0.19	10.6	1019
2/5/2008	1204	0.3	0	0	0.22		93.3		11.2	1019
2/5/2008	1412	0.2	0	0	1.5		87.6	0.18	12.6	1018
2/5/2008	1532	0.1	0	0	1.7		68.4		15.7	1019
2/5/2008	1614	0.1	0	0	1.9		64.9		16.4	1018
Tracer Test #6 (30 cfm total; 10 cfm to each INJ1, 2, and 3; ~8% H2)										
2/7/2008	1500	Test start								
2/7/2008	1513	0.0	0.02	0	1.1		56.7		21.4	1016
2/7/2008	1604	0.0	0.02	0	0.80		44.2		25.5	1016
2/8/2008	933	0.0	0	0	8.8		72.2	0.10	10.3	1017
Tracer Test #7 (60 cfm total; 20 cfm to each INJ1, 2, and 3, ~5% H2)										
1/17/2008	900	Test start								
1/17/2008	1008	13.5	0	0	0.22		96.8	0.02	7.7	1015
1/17/2008	1111	13.0	0	0	0.52		96.4	0.05	9.5	1015
1/17/2008	1215	6.8	0.02	0	2.9		93.2		10.3	1014
1/17/2008	1321	5.7	0.12	0	3.4		96.6		11.8	1013
1/17/2008	1448	5.1	0.10	0	3.9		87.4	0.03	12.7	1012

Aerojet GEDIT - Injection Test Input

Phase II Piezometer Monitoring Data

Well ID P3

Depth 18

Date	Time	Well or Injection Gas Sample						Well	Ambient Air
		O ₂ (%)	CO ₂ (%)	Propane (%)	H ₂ (%)	He (ppm)	RH (%)	Pressure (in wc)	Temperature (C°)

Tracer Test #8 (90 cfm total; 30 cfm each to INJ1, 2, and 3; ~4.5% H2)										
2/6/2008	1000	Test start								
2/6/2008	1014	0.1	0	0	0.50		92.6	0.28	11.1	1020
2/6/2008	1119	0.0	0	0	0.74		86.4		12.0	1020
2/6/2008	1226	0.0	0	0	1.4		92.8		13.3	1019
2/6/2008	1410	0.0	0	0	2.8		80.2	0.28	15.6	1017
2/6/2008	1520	0.0	0	0	2.9		73.2		16.6	1017
2/6/2008	1611	0.0	0	0	3.0		62.7		17.8	1017

Optimization Test #1 (90 cfm to INJ2 for 4 hours then shut down; ~88% N2, 10% H2, 1% CO2 & LPG)										
2/20/2008	1156	4.9	0.00	0	0.022		71.4		15	1010
2/20/2008	1206	Test start								
2/20/2008	1531	4.1	0.00	0.06	3.8		54.5		23	1007
2/20/2008	1606	Test End								
2/20/2008	1653	3.1	0.00	0.26	5.2		54.7		21.2	1008
2/21/2008	950	1.7	0.00	0.46	6.9		83.2		10.6	1005
2/22/2008	1109	2.1	0.00	0.5	4.2		85.4		10.2	1003

Aerojet GEDIT - Injection Test Input

Phase II Piezometer Monitoring Data

Well ID P3

Depth 18

Date	Time	Well or Injection Gas Sample						Well	Ambient Air
		O ₂ (%)	CO ₂ (%)	Propane (%)	H ₂ (%)	He (ppm)	RH (%)	Pressure (in wc)	Temperature (C°)
Optimization Test #2 (30 cfm to INJ2 for 12 hours then shut down; ~88% N2, 10% H2, 1% CO2 & LPG)									
2/25/2008	1845 Test Start								
2/26/2008	653 Test End								
2/26/2008	741	3.8	0.1	0.5	3.3		86.2	5.1	1017
2/27/2008	1610	1.2	0	0.42	2.9		46.6	29.2	1009
2/28/2008	1120	1.8	0	0.4	1.4		84.3	16.6	1007
Optimization Test #3A (1 cfm to INJ2; ~88% N2, 10% H2, 1% CO2 & LPG)									
2/29/2008	1319 Test Start								
2/29/2008	1506	3	0	0.38	0.1		51.9	26.5	1009
3/3/2008	1114	2.9	0	0.38	0.84		67.3	16.2	1019
3/3/2008	1130 Test End								
Optimization Test #3B (1 cfm to INJ1, INJ2 & INJ3; ~88% N2, 10% H2, 1% CO2 & LPG)									
3/3/2008	1130 Test Start								
3/4/2008	1000	2.6	0	0.4	2.9		77.3	14.6	1013
3/7/2008	1130	0.8	0	0.6	4.2		67.4	20	1018
3/7/2008	1306 Test End								
Optimization Test #3C (90 cfm to INJ1, INJ2 & INJ3 for 15 minutes then shut down; ~79% N2, 10% H2 & LPG, 1% CO2)									
3/7/2008	1306 Start Pulse								
3/7/2008	1321 End Pulse								
3/7/2008	1354	0.9	0	0.58	3.8		61.4	23	1016
3/10/2008	1117	3.4	0	0.78	0.046		80.5	17.2	1016

Aerojet GEDIT - Injection Test Input

Phase II Piezometer Monitoring Data

Well ID P3

Depth 18

Date	Time	Well or Injection Gas Sample						Well	Ambient Air
		O ₂ (%)	CO ₂ (%)	Propane (%)	H ₂ (%)	He (ppm)	RH (%)	Pressure (in wc)	Temperature (C°)
Optimization Test #4 (2, 45-minutes pulses; daily 15-minutes pulses w/30cfh constant flow)									
3/10/2008	1239	3.6	0.08	0.76	0.01		68.6	20.9	1016
3/10/2008	1321	3.7	0.08	0.76	0.022				1016
3/10/2008	1347	End pulse							
3/10/2008	1412	3.8	0.08	0.74	0.1		59.4	22.6	1015
3/11/2008	939	3.1	0.10	1.24	1.4		68.4	15.5	1018
3/12/2008	1005	2.2	0.06	1.58	1.7		80.8	12.9	1014
3/13/2008	919	1.6	0.02	2	1.3		78.2	14	1011
3/14/2008	1143	1.6	0.04	2	0.8		80	14.1	1013
3/14/2008	1218	1.6	0.04	2	0.79		75.8	14.8	1012
3/15/2008	1128	1.6	0.06	2.5	0.46		80.1	11.2	1009
3/16/2008	1115	2.2	0.00	2.5	0.22		71.9	14.1	1009
3/17/2008	927	2.4	0.06	2	0.022		71.4	9.4	1014
Optimization Test #5 (20 cfm to INJ2 for 125 minutes while maintaing 30 cfh the rest of the time; ~80% N2, 10% H2 & LPG)									
3/17/2008	1037	Start Test							
3/17/2008	1300	2.1	0.0	2.5	0.022		73.1	17.7	1014
3/8/2008	945	2.5	0.02	2	0.89		65.9	13.1	1016
3/19/2008	1003	2.8	0.02	2.5	0.22		73.1	12.3	1013
3/20/2008	948	3.3	0.06	2.5	0.22		80.3	9.8	1016
3/20/2008	~1100	End Test							

Aerojet GEDIT - Injection Test Input

Phase II Piezometer Monitoring Data

Well ID P3

Depth 18

Date	Time	Well or Injection Gas Sample						Well	Ambient Air
		O ₂ (%)	CO ₂ (%)	Propane (%)	H ₂ (%)	He (ppm)	RH (%)	Pressure (in wc)	Temperature (C°)
Optimization Test #6 (50 cfh to P4-18 & P4-28; ~80% N2, 10% H2 & LPG)									
3/20/2008	1330 Start Test								
3/21/2008	951	0.7	0.06	2.0	3.0		81.1	10.5	1020
3/24/2008	1021	0.0	0.08	2.0	3.2		71.4	16.1	1012
3/26/2008	1037	0.0	0.04	2.0	3.8		84.6	12.3	1017
3/28/2008	1003	0.0	0.04	2.0	2.6		67.5	10.7	1009
3/31/2008	1008	0.0	0.02	10.0	9.0		79.1	10.6	1013
4/2/2008	1113	0.0	0.02	11.5	8.6		75.2	16.7	1008
Optimization Test #7 (20 cfh to P4-18, --28, -38 (60 cfh total); ~80% N2, 10% H2 & LPG)									
4/2/2008	1233 Start Test								
4/4/2008	956	0.1	0.00	11.0	9.8		74.2	13.7	1013
4/7/2008	1426	0.2	0.06	8.5	15.0		72.4	19.4	1011
Optimization Test #7B (30 cfh to P4-18, & P4-28 (60 cfh total); ~80% N2, 10% H2 & LPG)									
4/7/2008	1458 Start Test								
4/9/2008	1130	0.3	0.00	2.5	22		81.3	15.3	1009
Optimization Test #7C (50 cfh to P4-18, & P4-28 (100 cfh total); ~79% N2, 10% H2 & LPG, 1% CO2)									
4/10/2009	1121 Start Test								
4/11/2008	1250	0.1	0.00	2.0	15.0		72.3	22.6	1012
4/14/2008	1022	1.1	0.20	13.0	4.6		80.1	15.3	1007
4/16/2008	1042	0.0	0.38	11.0	8.2		62.7	17.0	1011
4/22/2008	1001	0.0	0.38	9.5	13		91.6	15.9	1009

Aerojet GEDIT - Injection Test Input

Phase II Piezometer Monitoring Data

Well ID P3

Depth 18

Date	Time	Well or Injection Gas Sample						Well	Ambient Air	
		O ₂ (%)	CO ₂ (%)	Propane (%)	H ₂ (%)	He (ppm)	RH (%)	Pressure (in wc)	Temperature (C°)	Barometric pressure (mbar)
4/23/2008	919	0.0	0.22	10.0	4.1		76.3		13.4	1010
4/25/2008	1014	0.7	0.22	9.5	0.10		60.2		23.9	1015
4/29/2008	1123	0.0	0.16	9.0	6.1		66.8		25.5	1007
5/5/2008	1328	0.0	0.24	8.5	9.3		39.1		38.2	1001
5/13/2008	952	1.0	0.36	9.0	1.7		40.6		35.2	1007
5/20/2008	950	0.0	0.38	8.0	15		66.5		22.9	1004
5/23/2008	1538	2.2	0.28	7.5	7.3		57.5		29.0	990
5/27/2008	922	0.0	0.56	9.5	7.8		70.0		18.1	1007
6/4/2008	924	0.0	0.36	9.5	5.4		63.4		25.2	1002
6/12/2008	1220	0.9	0.34	8.5	2.6		31.2		42.7	1003
6/20/2008	1048	0.0	0.50	8.5	5.6		33.2		41.3	1005
6/25/2008	1103	0.0	0.44	8.5	11.0		53.6		31.4	1005
7/2/2008	1207	0.0	0.50	9.0	11.0		54.1		33.2	1004
7/7/2008	1153	0	0.4	9.0	6.3		41.5		36.3	998
7/18/2008	1120	0	0.42	9.0	9.2		80.1		26.7	
7/24/2008	1036	0.0	0.36	9.0	11.000		68.7		27.2	1005
7/31/2008	1031	0.0	0.46	9.5	10.000		75.5		26.2	1003
8/7/2008	909	0.0	0.46	9.5	8.7		85.1		20.7	1004
8/12/2008	1013	0.0	0.28	9.0	9.8		52.3		28.7	1002

Aerojet GEDIT - Injection Test Input

Phase II Piezometer Monitoring Data

Well ID P3

Depth 18

Date	Time	Well or Injection Gas Sample						Well	Ambient Air
		O ₂ (%)	CO ₂ (%)	Propane (%)	H ₂ (%)	He (ppm)	RH (%)	Pressure (in wc)	Temperature (C°)
Optimization Test #8 (100 cfh of 100% Propane to P4-18, & P4-28 (50 cfh to each point)									
9/8/2008	0905 Test Start								
9/8/2008	1104	8.3	0.48	6.0	0.002				999
9/15/2008	930	4.4	1.9	5.0	0.005		46.6	27.0	1007
9/29/2008	958	9.3	3.30	3.0	0.005		56.8	24.0	1006
10/13/2008	1216	3.8	0.42	30	0.005		46.2	27.8	1017
10/20/2008	1143	2.4	0.48	30	0.005		57.4	27.3	1013
11/5/2008	1333	2.0	0.52	30	0.005		77.9	19.0	1016
11/17/2008	1129	1.6	0.48	30	0.005		62.1	26.4	1014
12/1/2008	1101	1.7	0.52	30	0.002		65.3	20.6	1014

Aerojet GEDIT - Injection Test Input

Phase II Piezometer Monitoring Data

Well ID P3

Depth 28

Date	Time	Well or Injection Gas Sample						Well	Ambient Air		
		O ₂ (%)	CO ₂ (%)	Propane (%)	H ₂ (%)	He (ppm)	RH (%)	Pressure (in wc)	Temperature (C°)	Barometric pressure (mbar)	
12/12/2007	1230	19.8	0.14	0	0.002	100,000	76.3	0.02	12.7	1020	
12/12/2007	1536							0.22			
12/13/2007	856	11.3	0	0	7.4		80.4		6.4	1016	
12/13/2007	943	14.1	0	0	7.7		68.5		11.4	1016	
12/13/2007	1200	Discovered leak in O2 - all O2 data for 12/13/07 before 1200 invalid									
12/13/2007	1320							0.18			
12/13/2007	1330	0	0	0	8.4		64.2		16.8	1013	
12/13/2007	1452	0	0.44	0.52	0.46		73.7		14.3	1013	
12/13/2007	1525	0	0.60	0.52	0.22		73.9		13.9	1013	
12/14/2007	820	0	0.14	0	0.5		77.0	0.03	4.6	1016	
12/21/2007	1131	14.9	0.44	0.02	0.46		80.8	0.02	10.2	1013	
12/26/2007	1203	17.7	0.42	0	0.22		76.6	0	12.9	1017	
12/26/2007	1508	13.8	0.5	0.02	0.46		86.5		10.4	1015	
12/26/2007	1555	6.1	0.52	0.02	2.6		82.5	0.04	10.6	1015	
12/27/2007	946	0.2	0.04	0.02	9.4		78	0.02	5.6	1018	
12/27/2007	1250	0.2	0	0	9.2		80.4		9	1017	
12/27/2007	1419	0.1	0	0	9.4		86.6		8.8	1017	
12/27/2007	1540	0.2	0	0	9.6		89.3	0.03	7.6	1017	
1/2/2008	1008	0.1	0	0	0.022		49.6	0.02	15.6	1012	

Aerojet GEDIT - Injection Test Input

Phase II Piezometer Monitoring Data

Well ID P3

Depth 28

Date	Time	Well or Injection Gas Sample						Well	Ambient Air
		O ₂ (%)	CO ₂ (%)	Propane (%)	H ₂ (%)	He (ppm)	RH (%)	Pressure (in wc)	Temperature (C°)

Tracer Test #1 (10 cfm to INJ2, ~7% H2)											
1/21/2008	1046	Test start									
1/21/2008	1117		6.1	0	0	0.10		78.4	0.06	8.4	1008
1/21/2008	1259		5.6	0	0	3.9		76.6		10.5	1006
1/21/2008	1452		5.5	0	0	5.4		74.5	0.06	10.8	1006
1/21/2008	1617		5.6	0	0	5.6		78.3	0.06	9.9	1006
1/22/2008	1049		4.9	0	0	6.8		81.4	0.01	6.7	1011
1/22/2008	1339		4.5	0	0	6.8		86.7		7.7	1009
1/23/2008	1051		4.7	0	0	6.8		98.1	0.04	7.3	1008
1/23/2008	1204*		4.5								

Tracer Test #2 (20 cfm to INJ2, ~8% H2)											
1/18/2008	1120	Test start									
1/18/2008	1139		5.0	0	0	0.046		88.4		12.7	1015
1/18/2008	1237		4.9	0	0	5.3		81.4	0.01	13.8	1014
1/18/2008	1328		5.3	0	0	6.6		74.5		15.4	1014
1/18/2008	1513		4.8	0	0	6.8		64.5	0.04	17.5	1014
1/19/2008	940		4.9	0.06	0	8.4		67.1	0.02	13.0	1019
1/19/2008	1105*		4.6	0	0	6.4		56.2		16.8	1018

Aerojet GEDIT - Injection Test Input

Phase II Piezometer Monitoring Data

Well ID P3

Depth 28

Date	Time	Well or Injection Gas Sample						Well	Ambient Air
		O ₂ (%)	CO ₂ (%)	Propane (%)	H ₂ (%)	He (ppm)	RH (%)	Pressure (in wc)	Temperature (C°)

Tracer Test #3 (30 cfm to INJ2, ~4% H2)										
1/30/2008	1036	Test start								
1/30/2008	1146	0.1	0	0	4.0		94.7	0.09	9.8	1020
1/30/2008	1304	0.1	0	0	4.1		95.0		11.9	1019
1/30/2008	1510	0.1	0	0	4.2		84.7	0.11	14.8	1018
1/31/2008	1024	0.1	0	0	4.0		89.5	0.14	9.0	1018
1/31/2008	1158	0.1	0	0	3.7		88.8		9.3	1018
1/31/2008	1416	0.1	0	0	3.7		85.4	0.14	8.6	1016
1/31/2008	1435									
1/31/2008	1550	0.1	0	0	3.7		85.2	0.05	8.2	1014

Tracer Test #4 (60 cfm to INJ2, ~7% H2)										
1/28/2008	1236	Test start								
1/28/2008	1309	0.2	0	0	5.6		96.2		10.7	1010
1/28/2008	1439	0.1	0	0	5.9		79.8	0.05	12.9	1011
1/28/2008	1624	0.1	0	0	6.3		88.6	0.11	9.2	1012
1/29/2008	839	0.1	0	0	6.8		89.4	0.22	5.1	1017
1/29/2008	1018*	0.2			6.4					

Aerojet GEDIT - Injection Test Input

Phase II Piezometer Monitoring Data

Well ID P3

Depth 28

Date	Time	Well or Injection Gas Sample						Well	Ambient Air	
		O ₂ (%)	CO ₂ (%)	Propane (%)	H ₂ (%)	He (ppm)	RH (%)	Pressure (in wc)	Temperature (C°)	Barometric pressure (mbar)
Tracer Test #5 (90 cfm to INJ2, ~3% H2)										
2/5/2008	1015	Test start								
2/5/2008	1106	0.1	0	0	3.0		96.3	0.28	10.6	1019
2/5/2008	1206	0.1	0	0	3.1		94.0		11.1	1019
2/5/2008	1412	0.1	0	0	3.6		88.0	0.28	12.6	1018
2/5/2008	1533	0.1	0	0	3.4		69.1		15.3	1019
2/5/2008	1615	0.1	0	0	3.3		65.1		16.0	1018
Tracer Test #6 (30 cfm total; 10 cfm to each INJ1, 2, and 3; ~8% H2)										
2/7/2008	1500	Test start								
2/7/2008	1515	0.1	0	0	0.046		55.3		21.4	1016
2/7/2008	1606	0.1	0	0	2.0		44.8		24.8	1016
2/8/2008	948	0.1	0	0	8.9		66.3	0.04	14.7	1017
Tracer Test #7 (60 cfm total; 20 cfm to each INJ1, 2, and 3, ~5% H2)										
1/17/2008	900	Test start								
1/17/2008	1016	16.6	0	0	0.64		96.3	0.01	8.1	1015
1/17/2008	1114	15.7	0	0	1.2		94.8	0.03	9.5	1015
1/17/2008	1226	12.8	0	0	2.4		79.6		10.7	1014
1/17/2008	1322	12.0	0.08	0	2.6		85.7		11.7	1013
1/17/2008	1449	9.9	0.08	0	3.7		13.4	0.03	12.8	1012

Aerojet GEDIT - Injection Test Input

Phase II Piezometer Monitoring Data

Well ID P3

Depth 28

Date	Time	Well or Injection Gas Sample						Well	Ambient Air	
		O ₂ (%)	CO ₂ (%)	Propane (%)	H ₂ (%)	He (ppm)	RH (%)	Pressure (in wc)	Temperature (C°)	Barometric pressure (mbar)
Tracer Test #8 (90 cfm total; 30 cfm each to INJ1, 2, and 3; ~4.5% H2)										
2/6/2008	1000	Test start								
2/6/2008	1016	0.1	0	0	0.50		85.0	0.36	11.5	1020
2/6/2008	1120	0.1	0	0	3.4		86.8		11.9	1020
2/6/2008	1227	0.1	0	0	3.9		89.0		13.3	1019
2/6/2008	1411	0.1	0	0	4.7		80.3	0.39	15.7	1017
2/6/2008	1521	0.1	0	0	4.5		71.5		16.5	1017
Optimization Test #1 (90 cfm to INJ2 for 4 hours then shut down; ~88% N2, 10% H2, 1% CO2 & LPG)										
2/20/2008	1157	7.7	0.00	0	0.1		71.2		14.9	1010
2/20/2008	1206	Test start								
2/20/2008	1532	0.1	0.88	1.02	11		56.9		22.5	1007
2/20/2008	1606	Test End								
2/20/2008	1654	0.1	0.72	1.04	9.3		54.9		21.1	1008
2/21/2008	952	2.8	0.58	0.7	6.7		83.6		10.7	1005
2/22/2008	1110	6.8	0.44	0.4	2.1		82.8		10.2	1003
Optimization Test #2 (30 cfm to INJ2 for 12 hours then shut down; ~88% N2, 10% H2, 1% CO2 & LPG)										
2/25/2008	1845	Test Start								
2/26/2008	653	Test End								
2/26/2008	742	0.1	2.16	0.48	6.7		86.8		5.1	1017
2/27/2008	1611	4.9	1.18	0.32	2		48.9		28.3	1009
2/28/2008	1121	7.1	1.02	0.26	0.85		82.2		16.6	1007

Aerojet GEDIT - Injection Test Input

Phase II Piezometer Monitoring Data

Well ID P3

Depth 28

Date	Time	Well or Injection Gas Sample						Well	Ambient Air
		O ₂ (%)	CO ₂ (%)	Propane (%)	H ₂ (%)	He (ppm)	RH (%)	Pressure (in wc)	Temperature (C°)
Optimization Test #3A (1 cfm to INJ2; ~88% N2, 10% H2, 1% CO2 & LPG)									
2/29/2008	1319	Test Start							
2/29/2008	1508	8.1	0.82	0.24	0.1		53.2	25.7	1009
3/3/2008	1115	7.7	0.74	0.36	1.8		66.5	16.1	1019
3/3/2008	1130	Test End							
Optimization Test #3B (1 cfm to INJ1, INJ2 & INJ3; ~88% N2, 10% H2, 1% CO2 & LPG)									
3/3/2008	1130	Test Start							
3/4/2008	1001	10.2	0.7	0.22	1.6		78.9	14.7	1013
3/7/2008	1133	10.1	0.4	0.18	1.8		66.7	20	1018
3/7/2008	1306	Test End							
Optimization Test #3C (90 cfm to INJ1, INJ2 & INJ3 for 15 minutes then shut down; ~79% N2, 10% H2 & LPG, 1% CO2)									
3/7/2008	1306	Start Pulse							
3/7/2008	1321	End Pulse							
3/7/2008	1355	8.8	0.38	0.28	2.8		59.3	22.9	1016
3/10/2008	1118	9.4	0.46	0.4	0.046		80.2	17.3	1016
Optimization Test #4 (2, 45-minutes pulses; daily 15-minutes pulses w/30cfh constant flow)									
3/10/2008	1240	9.7	0.56	0.4	0.022		68.2	21	1016
3/10/2008	1322	6.3	0.56	2.5	2.2				1016
3/10/2008	1347	End pulse							
3/10/2008	1413	1.7	0.64	6	8.1		60	22.5	1015
3/11/2008	940	3.5	0.70	4.5	4.1		66.9	15.5	1018

Aerojet GEDIT - Injection Test Input

Phase II Piezometer Monitoring Data

Well ID P3

Depth 28

Date	Time	Well or Injection Gas Sample						Well	Ambient Air	
		O ₂ (%)	CO ₂ (%)	Propane (%)	H ₂ (%)	He (ppm)	RH (%)	Pressure (in wc)	Temperature (C°)	Barometric pressure (mbar)
3/12/2008	1006	5.3	0.66	3	2.9		79		12.9	1014
3/13/2008	919	7.4	0.60	2.5	1.8		77		14	1011
3/14/2008	1144	7.8	0.60	2	1		79.3		14.2	1013
3/14/2008	1219	6.7	0.56	2	2.9		76.3		14.8	1012
3/15/2008	1129	9.8	0.60	1.74	0.46		79.6		11.2	1009
3/16/2008	1115	9.8	0.44	1.7	0.5		73.6		14.2	1009
3/17/2008	928	9.6	0.56	1.7	0.55		70		9.5	1014

Optimization Test #5 (20 cfm to INJ2 for 125 minutes while maintaing 30 cfh the rest of the time; ~80% N2, 10% H2 & LPG)										
3/17/2008	1037	Start Test								
3/17/2008	1301	0.3	0.32	9.5	8.9		76.1		17.7	1014
3/18/2008	946	3.7	0.44	7	3.6		66.7		13.1	1016
3/19/2008	1004	6.9	0.42	4	1.7		73.7		12.4	1013
3/20/2008	949	7.7	0.44	3	1.4		78.8		9.8	1016
3/20/2008	~1100	End Test								

Optimization Test #6 (50 cfh to P4-18 & P4-28; ~80% N2, 10% H2 & LPG)										
3/20/2008	1330	Start Test								
3/21/2008	952	0.2	0.15	2.0	5.1		77.7		10.7	1020
3/24/2008	1022	0.1	0.00	2.5	4.2		68.4		16.1	1012
3/26/2008	1037	0.1	0.00	2.0	5.0		87.9		12.4	1017
3/28/2008	1004	0.1	0	2.0	2.0		70.3		10.7	1009
3/31/2008	1009	0.0	0.0	17.0	11.0		80.5		10.6	1013
4/2/2008	1114	0.0	0.0	14.5	8.2		72.2		16.7	1008

Aerojet GEDIT - Injection Test Input

Phase II Piezometer Monitoring Data

Well ID P3

Depth 28

Date	Time	Well or Injection Gas Sample						Well	Ambient Air	
		O ₂ (%)	CO ₂ (%)	Propane (%)	H ₂ (%)	He (ppm)	RH (%)	Pressure (in wc)	Temperature (C°)	Barometric pressure (mbar)
Optimization Test #7 (20 cfh to P4-18, --28, -38 (60 cfh total); ~80% N2, 10% H2 & LPG)										
4/2/2008	1233	Start Test								
4/4/2008	957	0.1	0.00	12.5	7.5		71.6	13.7	1013	
4/7/2008	1427	3.0	0.00	8.5	3.6		73.1	19.3	1011	
Optimization Test #7B (30 cfh to P4-18, & P4-28 (60 cfh total); ~80% N2, 10% H2 & LPG)										
4/7/2008	1458	Start Test								
4/9/2008	1132	5.7	0.00	6.0	3.2		86.5	15.3	1009	
Optimization Test #7C (50 cfh to P4-18, & P4-28 (100 cfh total); ~79% N2, 10% H2 & LPG, 1% CO2)										
4/10/2009	1121	Start Test								
4/11/2008	1252	4.6	0.20	2.5	6.1		66.9	22.7	1012	
4/14/2008	1024	2.8	5.00	17.5	6.8		81.0	15.3	1007	
4/16/2008	1043	0.0	0.54	9.5	8.6		65.9	17.1	1011	
4/22/2008	1002	0.3	0.02	11.0	6.6		89.6	16.1	1009	
4/23/2008	920	0.1	0.02	8.5	0.046		78.7	13.2	1010	
4/25/2008	1016	0.0	0.02	9.0	0.10		59.5	23.7	1015	
4/29/2008	1124	0.1	0.08	9.5	7.6		67.4	25.5	1007	
5/5/2008	1328	0.1	0.98	9.5	8.1		40.8	38.3	1001	
5/13/2008	953	0.1	1.42	9.5	2.2		41.7	35.0	1007	
5/20/2008	952	0.1	0.68	8.5	1.7		70.4	23.0	1004	
5/23/2008	1539	0.2	0.78	9.0	5.8		65.1	28.9	990	
5/27/2008	923	0.1	2.26	10.0	8.4		76.1	18.4	1007	

Aerojet GEDIT - Injection Test Input

Phase II Piezometer Monitoring Data

Well ID P3

Depth 28

Date	Time	Well or Injection Gas Sample						Well	Ambient Air
		O ₂ (%)	CO ₂ (%)	Propane (%)	H ₂ (%)	He (ppm)	RH (%)	Pressure (in wc)	Temperature (C°)
6/4/2008	925	0.1	0.04	10.0	6.4		62.6	25.2	1002
6/12/2008	1221	0.1	0.94	10.0	2.5		34.7	42.8	1003
6/20/2008	1050	0.1	0.16	9.5	5.900		31.8	41.3	1005
6/25/2008	1104	0.0	1.06	9.5	10.0		62.2	31.1	1005
7/2/2008	1208	0.1	1.44	10.0	10.0		56.3	34.6	1004
7/7/2008	1154	0.1	0	8.0	3.5		52.5	36.4	998
7/18/2008	1121	0.1	0	10.0	9		90.7	26.9	
7/24/2008	1037	0.1	0.54	9.5	11.000		73.7	27.3	1005
7/31/2008	1032	0.0	1.26	10.0	11.000		69.3	26.1	1003
8/7/2008	910	0.2	0.02	9.0	10		82.6	20.8	1004
8/12/2008	1014	0.1	0.00	10.0	10		55.2	28.6	1002
Optimization Test #8 (100 cfh of 100% Propane to P4-18, & P4-28 (50 cfh to each point)									
9/8/2008	0905 Test Start								
9/8/2008	1106	4.4	1.16	30.0	0.005				999
9/15/2008	932	10.2	1.88	24	0.005		44.3	27.2	1007
9/29/2008	959	7.6	1.75	30	0.005		42.9	23.8	1006
10/13/2008	1218	3.8	0.08	30	0.022		51.4	27.2	1017
10/20/2008	1144	2.9	0.12	30	0.005		57.9	27.4	1013
11/5/2008	1334	3.4	0.16	30	0.005		80.5	19.1	1016
11/17/2008	1130	2.0	0.16	30	0.005		63.4	26.1	1014
12/1/2008	1102	1.9	0.18	30	0.002		65.1	20.6	1014

Aerojet GEDIT - Injection Test Input

Phase II Piezometer Monitoring Data

Well ID P3

Depth 38

Date	Time	Well or Injection Gas Sample							Well	Ambient Air	
		O ₂ (%)	CO ₂ (%)	Propane (%)	H ₂ (%)	He (ppm)	RH (%)	Pressure (in wc)	Temperature (C°)	Barometric pressure (mbar)	
12/12/2007	1231	19.4	0.00	0	0.002	60,000	80.9	0.01	12.7	1020	
12/12/2007	1535							0.22			
12/13/2007	857	8.6	0	0	3.3		82.2		6.9	1016	
12/13/2007	943	11.5	0	0	3.6		74.5		11.2	1016	
12/13/2007	1200	Discovered leak in O2 - all O2 data for 12/13/07 before 1200 invalid									
12/13/2007	1321							0.21			
12/13/2007	1331	0	0	0	8.3		70.8		16.6	1013	
12/13/2007	1454	0	0.06	0.30	4.1		80.0		14.5	1013	
12/13/2007	1527	0	0.12	0.38	2.6		80.2		13.5	1013	
12/14/2007	822	0	0.02	0.08	0.5		78.7	0.02	4.9	1016	
12/21/2007	1133	14.4	0.04	0.04	0.46		82.4	0.01	9.9	1013	
12/26/2007	1205	18.6	0		0.22		68.6	0.02	13.4	1017	
12/26/2007	1509	16.7	0	0.02	0.22		87.8		10.3	1015	
12/26/2007	1557	16.9	0	0.02	0.22		83.1	0.08	10.6	1015	
12/27/2007	948	7.8	0	0.04	3.6		80.5	0.02	5.7	1018	
12/27/2007	1252	8.1	0	0	4.5		82.8		8.9	1016	
12/27/2007	1420	7.6	0	0	5.1		87.6		8.8	1017	
12/27/2007	1541	7.1	0	0	5.7		90.3	0.04	7.6	1017	
1/2/2008	1009	0.6	0.04	0	0.22		49.6	0.02	15.9	1012	

Aerojet GEDIT - Injection Test Input

Phase II Piezometer Monitoring Data

Well ID P3

Depth 38

Date	Time	Well or Injection Gas Sample						Well	Ambient Air
		O ₂ (%)	CO ₂ (%)	Propane (%)	H ₂ (%)	He (ppm)	RH (%)	Pressure (in wc)	Temperature (C°)

Tracer Test #1 (10 cfm to INJ2, ~7% H2)										
1/21/2008	1046	Test start								
1/21/2008	1118	1.9	0.02	0	0.10		77.1	0.06	8.6	1008
1/21/2008	1301	1.7	0	0	0.046		75.3		10.5	1006
1/21/2008	1453	1.7	0	0	0.046		74.6	0.06	10.8	1006
1/21/2008	1616	1.8	0	0	0.79		80.5	0.04	9.9	1006
1/22/2008	1047	1.2	0.06	0	6.1		84.1	0.06	6.7	1011
1/22/2008	1340	1.0	0	0	6.3		87.6		7.8	1009
1/23/2008	1053	1.0	0.06	0	6.7		98.2	0.05	7.3	1008
1/23/2008	1206*	0.8								

Tracer Test #2 (20 cfm to INJ2, ~8% H2)										
1/18/2008	1120	Test start								
1/18/2008	1140	1.4	0	0	0.10		87.3		12.7	1015
1/18/2008	1239	1.4	0	0	0.10		78.7	0.01	13.7	1014
1/18/2008	1330	1.6	0	0	0.22		74.3		15.3	1014
1/18/2008	1514	1.5	0	0	2.6		62.9	0.04	17.0	1014
1/19/2008	941	1.3	0.08	0	10.0		65.2	0.01	13.4	1019
1/19/2008	1106*	0.8	0.02	0	9.3		54.2		17.3	1018

Aerojet GEDIT - Injection Test Input

Phase II Piezometer Monitoring Data

Well ID P3

Depth 38

Date	Time	Well or Injection Gas Sample						Well	Ambient Air
		O ₂ (%)	CO ₂ (%)	Propane (%)	H ₂ (%)	He (ppm)	RH (%)	Pressure (in wc)	Temperature (C°)

Tracer Test #3 (30 cfm to INJ2, ~4% H2)										
1/30/2008	1036	Test start								
1/30/2008	1149	0.0	0	0	1.0		95.8	0.12	9.9	1020
1/30/2008	1301	0.0	0	0	1.9		94.6		11.9	1019
1/30/2008	1511	0.0	0	0	3.6		87.2	0.11	14.7	1018
1/31/2008	1026	0.0	0	0	4.1		90.0	0.13	9.0	1018
1/31/2008	1159	0	0	0	3.9		88.5		9.3	1018
1/31/2008	1420	0	0.02	0	3.8		85.3	0.11	8.5	1016
1/31/2008	1435									
1/31/2008	1551	0	0	0	3.7		84.8	0.05	8.1	1014

Tracer Test #4 (60 cfm to INJ2, ~7% H2)										
1/28/2008	1236	Test start								
1/28/2008	1311	2.4	0.04	0	0.2		96.9		10.6	1010
1/28/2008	1441	0.4	0.04	0	4.7		85.7	0.11	12.8	1011
1/28/2008	1625	0.3	0.04	0	5.4		88.3	0.21	9.2	1012
1/29/2008	841	0	0.08	0	7.1		92.8	0.21	5.0	1017
1/29/2008	Final O2*	0								

Aerojet GEDIT - Injection Test Input

Phase II Piezometer Monitoring Data

Well ID P3

Depth 38

Date	Time	Well or Injection Gas Sample						Well	Ambient Air	
		O ₂ (%)	CO ₂ (%)	Propane (%)	H ₂ (%)	He (ppm)	RH (%)	Pressure (in wc)	Temperature (C°)	Barometric pressure (mbar)
Tracer Test #5 (90 cfm to INJ2, ~3% H2)										
2/5/2008	1015	Test start								
2/5/2008	1107	0.7	0	0	1.3		97.3	0.39	10.6	1019
2/5/2008	1207	0.4	0	0	2.5		94.1		11.1	1019
2/5/2008	1413	0.2	0	0	3.3		89.5	0.32	12.5	1018
2/5/2008	1534	0.1	0	0	3.3		71.8		14.8	1019
2/5/2008	1616	0.1	0	0	3.3		66.2		15.6	1018
Tracer Test #6 (30 cfm total; 10 cfm to each INJ1, 2, and 3; ~8% H2)										
2/7/2008	1500	Test start								
2/7/2008	1516	0.0	0.02	0	0.046		56.7		21.3	1016
2/7/2008	1607	0.0	0	0	0.10		46.3		23.9	1016
2/8/2008	949	0.0	0	0	8.7		66.6	0.00	15.1	1017
Tracer Test #7 (60 cfm total; 20 cfm to each INJ1, 2, and 3, ~5% H2)										
1/17/2008	900	Test start								
1/17/2008	1014	8.4	0	0	2.0		95.9	0.02	8.0	1015
1/17/2008	1115	7.8	0	0	2.8		96.0	0.02	9.8	1015
1/17/2008	1231	5.5	0	0	3.8		90.9		10.8	1014
1/17/2008	1324	3.4	0.06	0	4.2		87.4		11.6	1013
1/17/2008	1452	2.7	0.06	0	5.0		80.8	0.02	12.9	1012

Aerojet GEDIT - Injection Test Input

Phase II Piezometer Monitoring Data

Well ID P3

Depth 38

Date	Time	Well or Injection Gas Sample						Well	Ambient Air	
		O ₂ (%)	CO ₂ (%)	Propane (%)	H ₂ (%)	He (ppm)	RH (%)	Pressure (in wc)	Temperature (C°)	Barometric pressure (mbar)
Tracer Test #8 (90 cfm total; 30 cfm each to INJ1, 2, and 3; ~4.5% H2)										
2/6/2008	1000	Test start								
2/6/2008	1017	0.1	0	0	0.55		84.1	0.32	11.8	1020
2/6/2008	1121	0.0	0	0	2.1		88.7		12.0	1020
2/6/2008	1229	0.0	0	0	2.8		90.8		13.4	1019
2/6/2008	1412	0.0	0	0	4.2		82.2	0.30	15.7	1017
2/6/2008	1522	0.0	0	0	4.2		73.4		16.4	1017
Optimization Test #1 (90 cfm to INJ2 for 4 hours then shut down; ~88% N2, 10% H2, 1% CO2 & LPG)										
2/20/2008	1158	7.2	0.00	0	0.046		70.6		14.9	1010
2/20/2008	1206	Test start								
2/20/2008	1533	0.4	0.00	0.94	11		56.4		21.9	1007
2/20/2008	1606	Test End								
2/20/2008	1656	0.2	0.00	0.96	10		54.9		21	1008
2/21/2008	953	1.3	0.02	0.92	6.9		82.2		10.7	1005
2/22/2008	1111	6	0.00	0.42	1.7		82.6		10.2	1003
Optimization Test #2 (30 cfm to INJ2 for 12 hours then shut down; ~88% N2, 10% H2, 1% CO2 & LPG)										
2/25/2008	1845	Test Start								
2/26/2008	653	Test End								
2/26/2008	744	0.1	0.16	0.64	6.6		86.4		5.2	1017
2/27/2008	1612	3.0	0.12	0.42	1.4		49.8		29.8	1009
2/28/2008	1122	6.3	0.08	0.28	0.46		82.9		16.7	1007

Aerojet GEDIT - Injection Test Input

Phase II Piezometer Monitoring Data

Well ID P3

Depth 38

Date	Time	Well or Injection Gas Sample						Well	Ambient Air
		O ₂ (%)	CO ₂ (%)	Propane (%)	H ₂ (%)	He (ppm)	RH (%)	Pressure (in wc)	Temperature (C°)
Optimization Test #3A (1 cfm to INJ2; ~88% N2, 10% H2, 1% CO2 & LPG)									
2/29/2008	1319								
2/29/2008	1509	7.3	0.04	0.26	0.046		54.3	24.9	1009
3/3/2008	1116	12	0.12	0.08	0.022		71	16.1	1019
3/3/2008	1130								
Optimization Test #3B (1 cfm to INJ1, INJ2 & INJ3; ~88% N2, 10% H2, 1% CO2 & LPG)									
3/3/2008	1130								
3/4/2008	1003	12.1	0.14	0.08	0.022		77.6	14.7	1013
3/7/2008	1134	12.1	0.04	0.08	0.022		67.5	20	1018
3/7/2008	1306								
Optimization Test #3C (90 cfm to INJ1, INJ2 & INJ3 for 15 minutes then shut down; ~79% N2, 10% H2 & LPG, 1% CO2)									
3/7/2008	1306								
3/7/2008	1321								
3/7/2008	1357	12	0.02	0.06	0.022		60.6	22.8	1016
3/10/2008	1119	9.9	0.08	0.2	0.046		71.8	17.4	1016
Optimization Test #4 (2, 45-minutes pulses; daily 15-minutes pulses w/30cfh constant flow)									
3/10/2008	1241	10.1	0.14	0.22	0.022		67.8	21.1	1016
3/10/2008	1323	10.0	0.14	0.22	0.046		65.7	21.6	1016
3/10/2008	1347	End pulse							
3/10/2008	1414	9.9	0.12	0.22	0.046		61.8	22.5	1015
3/11/2008	941	7.2	0.14	1.68	1.3		67.6	15.4	1018

Aerojet GEDIT - Injection Test Input

Phase II Piezometer Monitoring Data

Well ID P3

Depth 38

Date	Time	Well or Injection Gas Sample						Well	Ambient Air	
		O ₂ (%)	CO ₂ (%)	Propane (%)	H ₂ (%)	He (ppm)	RH (%)	Pressure (in wc)	Temperature (C°)	Barometric pressure (mbar)
3/12/2008	1007	7.7	0.10	2	0.1		81.2		12.9	1014
3/13/2008	921	9.0	0.08	1.8	0.046		76.7		14	1011
3/14/2008	1145	10.3	0.10	1.36	0.022		78.5		14.3	1013
3/14/2008	1220	10.2	0.08	1.34	0.022		76.4		14.8	1012
3/15/2008	1130	11.6	0.12	0.94	0.022		81.4		11.1	1009
3/16/2008	1116	12.0	0.04	0.84	0.022		74.5		14.2	1009
3/17/2008	930	12.1	0.12	0.98	0.022		70.3		9.7	1014

Optimization Test #5 (20 cfm to INJ2 for 125 minutes while maintaing 30 cfm the rest of the time; ~80% N2, 10% H2 & LPG)										
3/17/2008	1037	Start Test								
3/17/2008	1302	11.3	0.04	0.98	0.5		79.7		17.8	1014
3/18/2008	947	7.6	0.08	3	1.1		67.6		13.2	1016
3/19/2008	1005	6.3	0.08	4.5	0.57		73.9		12.4	1013
3/20/2008	950	6.7	0.08	4	0.22		78.4		9.9	1016
3/20/2008	~1100	End Test								

Optimization Test #6 (50 cfm to P4-18 & P4-28; ~80% N2, 10% H2 & LPG)										
3/20/2008	1330	Start Test								
3/21/2008	954	6.5	0.12	4.0	0.50		86.7		11.0	1020
3/24/2008	1032	6.8	0.16	2.0	0.10		76.7		16.6	1012
3/26/2008	1038	5.7	0.12	2.0	0.22		91.5		12.4	1017
3/28/2008	1005	5.1	0.14	2.0	0.2		68.0		10.7	1009
3/31/2008	1010	0.0	0.12	13.5	5.6		83.3		10.6	1013
4/2/2008	1115	0.0	0.14	13.0	3.6		72.3		16.7	1008

Aerojet GEDIT - Injection Test Input

Phase II Piezometer Monitoring Data

Well ID P3

Depth 38

Date	Time	Well or Injection Gas Sample						Well	Ambient Air	
		O ₂ (%)	CO ₂ (%)	Propane (%)	H ₂ (%)	He (ppm)	RH (%)	Pressure (in wc)	Temperature (C°)	Barometric pressure (mbar)
Optimization Test #7 (20 cfh to P4-18, --28, -38 (60 cfh total); ~80% N2, 10% H2 & LPG)										
4/2/2008	1233	Start Test								
4/4/2008	958	0.0	0.12	3.0	2.8		75.8	13.8	1013	
4/7/2008	1429	3.2	0.12	9.5	0.5		76.4	19.1	1011	
Optimization Test #7B (30 cfh to P4-18, & P4-28 (60 cfh total); ~80% N2, 10% H2 & LPG)										
4/7/2008	1458	Start Test								
4/9/2008	1133	4.5	0.06	8.5	0.046		86.0	15.3	1009	
Optimization Test #7C (50 cfh to P4-18, & P4-28 (100 cfh total); ~79% N2, 10% H2 & LPG, 1% CO2)										
4/10/2009	1121	Start Test								
4/11/2008	1244	4.9	0.12	8.0	0.1		67.8	22.7	1012	
4/14/2008	1025	0.0	4.14	25.0	8.2		81.2	15.2	1007	
4/16/2008	1044	0.5	2.78	11.5	2.8		63.9	17.2	1011	
4/22/2008	1004	3.3	1.14	4.0	1.0		78.5	16.3	1009	
4/23/2008	922	0.0	1.10	8.5	0.22		75.3	13.1	1010	
4/25/2008	1018	0.0	0.86	9.5	0.10		58.3	23.6	1015	
4/29/2008	1126	0.0	0.74	8.5	1.6		66.1	25.7	1007	
5/5/2008	1330	1.2	0.44	6.5	0.67		39.7	38.5	1001	
5/13/2008	954	0.0	0.60	9.5	1.0		41.8	34.9	1007	
5/20/2008	953	0.0	0.78	8.5	0.10		71.9	23.0	1004	
5/23/2008	1541	4.4	0.62	6.5	0.10		61.5	28.8	990	
5/27/2008	924	1.1	0.64	7.5	1.0		74.4	18.6	1007	

Aerojet GEDIT - Injection Test Input

Phase II Piezometer Monitoring Data

Well ID P3

Depth 38

Date	Time	Well or Injection Gas Sample						Well	Ambient Air
		O ₂ (%)	CO ₂ (%)	Propane (%)	H ₂ (%)	He (ppm)	RH (%)	Pressure (in wc)	Temperature (C°)
6/4/2008	926	0.0	0.46	8.0	1.1		64.0	25.3	1002
6/12/2008	1223	0.5	0.48	8.5	0.22		31.3	43.1	1003
6/20/2008	1051	0.0	0.44	8.0	1.1		33.2	41.5	1005
6/25/2008	1105	0.0	0.40	8.0	0.10		58.3	30.9	1005
7/2/2008	1209	0.0	0.40	8.0	0.50		48.1	35.6	1004
7/7/2008	1156	0	0.42	7.5	1.3		44	36.4	998
7/18/2008	1123	0	0.54	8.0	0.78		81.4	26.9	
7/24/2008	1030	0.0	0.58	8.0	0.65		69.4	27.4	1005
7/31/2008	1033	0.0	0.64	8.0	1.2		72.8	26.2	1003
8/7/2008	911	0.0	0.68	8.5	1.5		81.8	20.7	1004
8/12/2008	1015	0.0	0.64	8.5	1.2		58	28.7	1002
Optimization Test #8 (100 cfh of 100% Propane to P4-18, & P4-28 (50 cfh to each point)									
9/8/2008	0905 Test Start								
9/8/2008	1108	3.2	2.00	27.0	0.005				999
9/15/2008	933	1.1	1.32	30	0.005		43.5	27.2	1007
9/29/2008	1000	0.2	0.62	30	0.005		42.2	23.5	1006
10/13/2008	1219	0.8	0.30	30	0.010		47.2	27.0	1017
10/20/2008	1146	0.4	0.28	30	0.005		57.8	27.5	1013
11/5/2008	1335	0.4	0.26	30	0.005		78.6	19.5	1016
11/17/2008	1130	0.1	0.20	30	0.010		66.4	26.0	1014
12/1/2008	1102	0.0	0.18	30	0.005		65.7	20.7	1014

Aerojet GEDIT - Injection Test Input

Phase II Piezometer Monitoring Data

Well ID P3

Depth 48

Date	Time	Well or Injection Gas Sample						Well	Ambient Air		
		O ₂ (%)	CO ₂ (%)	Propane (%)	H ₂ (%)	He (ppm)	RH (%)	Pressure (in wc)	Temperature (C°)	Barometric pressure (mbar)	
12/12/2007	1232	20.7	0.00	0	0.002	100,000	76.3	0.02	12.7	1020	
12/12/2007	1535							0.16			
12/13/2007	859	14.0	0	0	1.0		75.6		7.5	1016	
12/13/2007	945	17.0	0	0	1.3		71.0		10.9	1016	
12/13/2007	1200	Discovered leak in O2 - all O2 data for 12/13/07 before 1200 invalid									
12/13/2007	1321							0.05			
12/13/2007	1332	0	0.04	0	8.0		63.4		16.6	1013	
12/13/2007	1456	0	0.06	0.22	5.7		71.0		14.5	1013	
12/13/2007	1528	0	0.04	0.38	3.0		77.0		13.1	1013	
12/14/2007	824	0	0.04	0.28	1.7		76.3	0.02	4.9	1016	
12/21/2007	1135	20.9	0.08	0	0.22		85.6	0.02	9.6	1012	
12/26/2007	1207	20.9	0.02	0	0.022		69.9	0	13.7	1017	
12/26/2007	1510	20.9	0.02	0	0.22		87.2		10.3	1015	
12/26/2007	1600	20.7	0.02	0	0.22		83.4	0.09	10.5	1015	
12/27/2007	950	20.9	0.04	0.02	0.22		78.7	0.02	5.6	1018	
12/27/2007	1254	20.9	0	0	0.22		82.5		8.9	1016	
12/27/2007	1423	20.9	0	0	0.22		86.7		8.7	1017	
12/27/2007	1543	20.9	0	0	0.22		90.7	0.03	7.5	1017	
1/2/2008	1011	20.9	0.08	0	0.22		48.1	0.02	16.5	1012	

Aerojet GEDIT - Injection Test Input

Phase II Piezometer Monitoring Data

Well ID P3

Depth 48

Date	Time	Well or Injection Gas Sample						Well	Ambient Air
		O ₂ (%)	CO ₂ (%)	Propane (%)	H ₂ (%)	He (ppm)	RH (%)	Pressure (in wc)	Temperature (C°)

Tracer Test #1 (10 cfm to INJ2, ~7% H2)									
1/21/2008	1046 Test start								
1/21/2008	1119	4.8	0.06	0	1.3	90.6	0.07	8.9	1008
1/21/2008	1303	4.8	0.06	0	1.2	77.6		10.4	1006
1/21/2008	1455	13.8	0.06	0	0.22	81.8	0.09	10.8	1006
1/21/2008	1615	18.7	0.04	0	0.046	83.4	0.03	9.9	1006
1/22/2008	1050	20.9	0.10	0	0.022	82.8	0.03	6.8	1011
1/22/2008	1342	20.7	0.04	0	0.022	88.3		7.9	1009
1/23/2008	1055	20.9	0.08	0	0.022	98.4	0.04	7.3	1008
1/23/2008	1207*	20.9							

Tracer Test #2 (20 cfm to INJ2, ~8% H2)									
1/18/2008	1120 Test start								
1/18/2008	1141	5.2	0	0	1.2	91.6		12.8	1015
1/18/2008	1241	5.6	0.02	0	1.2	87.5	0.01	13.8	1014
1/18/2008	1331	6.4	0	0	1.2	73.1		15.2	1014
1/18/2008	1515	7.1	0.02	0	1.1	64.7	0.03	17.1	1014
1/19/2008	942	5.8	0.14	0	3.3	62.9	0.01	13.9	1019
1/19/2008	1108*	5.1	0.06	0	4.1	63.6		17.6	1019

Aerojet GEDIT - Injection Test Input

Phase II Piezometer Monitoring Data

Well ID P3

Depth 48

Date	Time	Well or Injection Gas Sample						Well	Ambient Air
		O ₂ (%)	CO ₂ (%)	Propane (%)	H ₂ (%)	He (ppm)	RH (%)	Pressure (in wc)	Temperature (C°)

Tracer Test #3 (30 cfm to INJ2, ~4% H2)										
1/30/2008	1036	Test start								
1/30/2008	1149	1.0	0.10	0	1.1		95.9	0.12	9.8	1020
1/30/2008	1305	0.5	0.16	0	0.97		96.7		12.0	1019
1/30/2008	1512	0.4	0.18	0	1.5		90.3	0.09	14.7	1018
1/31/2008	1027	0.1	0.28	0	2.7		91.5	0.12	8.9	1018
1/31/2008	1200	0.1	0.32	0	3.2		91.9		9.3	1018
1/31/2008	1421	0.1	0.34	0	3.1		90.4	0.12	8.4	1015
1/31/2008	1435									
1/31/2008	1552	0.1	0.32	0	3.1		89.6	0.12	8.2	1014

Tracer Test #4 (60 cfm to INJ2, ~7% H2)										
1/28/2008	1236	Test start								
1/28/2008	1312									
1/28/2008	1442							0.03		
1/28/2008	1627									
1/29/2008	842	1.1	0.82	0	5.4		94.7	0.19	5.0	1017
1/29/2008	Final O2*	1.1								

Aerojet GEDIT - Injection Test Input

Phase II Piezometer Monitoring Data

Well ID P3

Depth 48

Date	Time	Well or Injection Gas Sample						Well	Ambient Air
		O ₂ (%)	CO ₂ (%)	Propane (%)	H ₂ (%)	He (ppm)	RH (%)	Pressure (in wc)	Temperature (C°)

Tracer Test #5 (90 cfm to INJ2, ~3% H2)										
2/5/2008	1015 Test start									
2/5/2008	1108	1.1	0.30	0	0.046		97.7	0.26	10.6	1019
2/5/2008	1208	1.2	0.32	0	0.22		93.6		11.1	1019
2/5/2008	1414	1.1	0.36	0	0.10		94.9	0.22	12.6	1018
2/5/2008	1535	1.1	0.44	0	0.65		69.2		14.6	1019
2/5/2008	1617	1.1	0.44	0	0.88		65.9		16.4	1018

Tracer Test #6 (30 cfm total; 10 cfm to each INJ1, 2, and 3; ~8% H2)										
2/7/2008	1500 Test start									
2/7/2008	1517	0.0	0.28	0	0.54		50.9		21.1	1016
2/7/2008	1608	0.0	0.28	0	0.46		44.8		23.5	1016
2/8/2008	950	0.0	0.26	0	5.1		65.7	0.06	15.4	1017
2/8/2008	1047	0.1	0.24	0	5.4		95.0		10.5	1017

Tracer Test #7 (60 cfm total; 20 cfm to each INJ1, 2, and 3, ~5% H2)										
1/17/2008	900 Test start									
1/17/2008	1018	13.6	0	0	0.22		96.3	0.01	8.3	1015
1/17/2008	1118	12.4	0	0	0.22		96.8	0.02	9.9	1015

Aerojet GEDIT - Injection Test Input

Phase II Piezometer Monitoring Data

Well ID P3

Depth 48

Date	Time	Well or Injection Gas Sample						Well	Ambient Air	
		O ₂ (%)	CO ₂ (%)	Propane (%)	H ₂ (%)	He (ppm)	RH (%)	Pressure (in wc)	Temperature (C°)	Barometric pressure (mbar)
1/17/2008	1232	11.8	0	0	0.22		94.5		10.8	1014
1/17/2008	1329	11.1	0.12	0	0.85		95.0		11.6	1013
1/17/2008	1456	10.3	0.12	0	1.6		82.7	0.02	12.9	1012

Tracer Test #8 (90 cfm total; 30 cfm each to INJ1, 2, and 3; ~4.5% H2)										
2/6/2008	1000 Test start									
2/6/2008	1019	0.3	0.34	0	0.022		77.7	0.22	12.3	1020
2/6/2008	1122	0.1	0.32	0	0.70		84.8		12.1	1020
2/6/2008	1229	0.1	0.28	0	1.7		83.9		13.4	1019
2/6/2008	1413	0.0	0.26	0	2.8		75.6	0.22	15.7	1017
2/6/2008	1523	0.0	0.24	0	3.0		68.9		16.2	1017
2/6/2008	1612	0.0	0.32	0	3.6					1017

Optimization Test #1 (90 cfm to INJ2 for 4 hours then shut down; ~88% N2, 10% H2, 1% CO2 & LPG)										
2/20/2008	1159	20.9	0.12	0	0.022		72.7		14.7	1010
2/20/2008	1206 Test start									
2/20/2008	1535	3.8	0.36	0.02	0.71		58.7		21.8	1007
2/20/2008	1606 Test End									
2/20/2008	1657	3.8	0.30	0.04	0.74		55.5		20.8	1008
2/21/2008	955	20.9	0.12	0	0.022		85		10.7	1005
2/22/2008	1112	20.9	0.08	0	0.022		83.5		10.2	1003

Aerojet GEDIT - Injection Test Input

Phase II Piezometer Monitoring Data

Well ID P3

Depth 48

Date	Time	Well or Injection Gas Sample						Well	Ambient Air	
		O ₂ (%)	CO ₂ (%)	Propane (%)	H ₂ (%)	He (ppm)	RH (%)	Pressure (in wc)	Temperature (C°)	Barometric pressure (mbar)
Optimization Test #2 (30 cfm to INJ2 for 12 hours then shut down; ~88% N2, 10% H2, 1% CO2 & LPG)										
2/25/2008	1845	Test Start								
2/26/2008	653	Test End								
2/26/2008	745	7.0	0.18	0.14	0.01		87.7	5.2	1017	
2/27/2008	1614	7.6	0.1	0.06	0.022		53.1	27.3	1009	
2/28/2008	1124	7.2	0.06	0.06	0.022		83.8	16.7	1007	
Optimization Test #3A (1 cfm to INJ2; ~88% N2, 10% H2, 1% CO2 & LPG)										
2/29/2008	1319	Test Start								
2/29/2008	1509	6.8	0.02	0.08	0.01		57.2	24.2	1009	
3/3/2008	1117	7	0.1	0.06	0.01		67.9	16.1	1019	
3/3/2008	1130	Test End								
Optimization Test #3B (1 cfm to INJ1, INJ2 & INJ3; ~88% N2, 10% H2, 1% CO2 & LPG)										
3/3/2008	1130	Test Start								
3/4/2008	1004	7.2	0.16	0.06	0.022		78.2	14.8	1013	
3/7/2008	1132	19.9	0.04	0	0.005		72.2	20	1018	
3/7/2008	1306	Test End								

Aerojet GEDIT - Injection Test Input

Phase II Piezometer Monitoring Data

Well ID P3

Depth 48

Date	Time	Well or Injection Gas Sample						Well	Ambient Air
		O ₂ (%)	CO ₂ (%)	Propane (%)	H ₂ (%)	He (ppm)	RH (%)	Pressure (in wc)	Temperature (C°)
Optimization Test #3C (90 cfm to INJ1, INJ2 & INJ3 for 15 minutes then shut down; ~79% N2, 10% H2 & LPG, 1% CO2)									
3/7/2008	1306	Start Pulse							
3/7/2008	1321	End Pulse							
3/7/2008	1357	16.4	0.04	0	0.01		61.9	22.7	1016
3/10/2008	1120	19.8	0.08	0	0.01		80.7	17.4	1017
Optimization Test #4 (2, 45-minutes pulses; daily 15-minutes pulses w/30cfh constant flow)									
3/10/2008	1415	15.0	0.12	0.02	0.005		62.8	22.5	1015
3/12/2008	1008	20.6	0.10	0	0.01		82.6	12.9	1014
3/13/2008	922	20.7	0.06	0	0.01		79.4	14.1	1011
3/14/2008	1146	20.8	0.08	0	0.01		79.4	14.4	1012
3/14/2008	1221	19.4	0.02	0.05	0.005		77.9	14.8	1012
3/15/2008	1131	20.7	0.06	0	0.01		83.7	11.1	1009
3/16/2008	1118	18.9	0.00	0.02	0.01		75.1	14.3	1009
3/17/2008	931	18.6	0.10	0	0.01		71.7	9.7	1014
Optimization Test #5 (20 cfm to INJ2 for 125 minutes while maintaing 30 cfh the rest of the time; ~80% N2, 10% H2 & LPG)									
3/17/2008	1037	Start Test							
3/17/2008	1303	12.9	0.06	0.26	0.022		82.1	17.8	1014
3/8/2008	948	19.7	0.08	0	0.022		71.9	13.3	1016

Aerojet GEDIT - Injection Test Input

Phase II Piezometer Monitoring Data

Well ID P3

Depth 48

Date	Time	Well or Injection Gas Sample						Well	Ambient Air	
		O ₂ (%)	CO ₂ (%)	Propane (%)	H ₂ (%)	He (ppm)	RH (%)	Pressure (in wc)	Temperature (C°)	Barometric pressure (mbar)
3/19/2008	1006	19.7	0.08	0	0.022		77.9		12.4	1013
3/20/2008	951	20.5	0.10	0	0.022		79.8		10	1016
3/20/2008	~1100	End Test								

Optimization Test #6 (50 cfh to P4-18 & P4-28; ~80% N2, 10% H2 & LPG)										
3/20/2008	1330 Start Test									
3/21/2008	956	19.7	0.10	0	0.01		77.9		11.2	1020
3/24/2008	1033*	12.9	0.24	0.78	0.022		73.8		16.6	1012
3/26/2008	1040	20.7	0.14	0	0.01		93.8		12.5	1017
3/28/2008	1006	18.9	0.18	0.06	0.010		72.6		10.7	1009
3/31/2008	1012	16.1	0.18	0.84	0.022		89.4		10.8	1013
4/2/2008	1116	5.4	0.30	7.5	0.046		70.4		16.7	1008

Optimization Test #7 (20 cfh to P4-18, --28, -38 (60 cfh total); ~80% N2, 10% H2 & LPG)										
4/2/2008	1233 Start Test									
4/4/2008	959	3.9	0.34	7.5	0.046		74.4		13.8	1013
4/7/2008	1430	9.6	0.42	5.0	0.046		75.6		19.1	1011

Optimization Test #7B (30 cfh to P4-18, & P4-28 (60 cfh total); ~80% N2, 10% H2 & LPG)										
4/7/2008	1458 Start Test									
4/9/2008	1135	8.3	0.32	5.0	0.01		88.0		15.4	1009

Aerojet GEDIT - Injection Test Input

Phase II Piezometer Monitoring Data

Well ID P3

Depth 48

Date	Time	Well or Injection Gas Sample						Well	Ambient Air	
		O ₂ (%)	CO ₂ (%)	Propane (%)	H ₂ (%)	He (ppm)	RH (%)	Pressure (in wc)	Temperature (C°)	Barometric pressure (mbar)
Optimization Test #7C (50 cfh to P4-18, & P4-28 (100 cfh total); ~79% N2, 10% H2 & LPG, 1% CO2)										
4/10/2009	1121	Start Test								
4/11/2008	1254	4.4	0.44	7.0	0.046		67.4	22.7	1012	
4/14/2008	1027	2.3	0.52	9.0	0.1		81.7	15.3	1007	
4/16/2008	1046	1.5	0.64	15.0	0.046		68.8	17.2	1011	
4/22/2008	1005	0.2	1.08	8.0	0.046		78.1	16.4	1009	
4/23/2008	923	0.1	1.26	9.0	0.10		76.1	13.1	1010	
4/25/2008	1019	0.0	1.10	9.5	0.10		60.6	23.6	1015	
4/29/2008	1127	0.0	0.98	10.0	0.1		68.2	26.2	1007	
5/5/2008	1331	0.0	0.94	10.0	0.1		38.4	38.6	1001	
5/13/2008	950	0.0	1.08	9.5	0.046		42.6	34.7	1007	
5/20/2008	954	0.0	1.12	9.5	0.046		74.7	23.2	1004	
5/23/2008	1542	0.0	1.38	8.0	0.22		60.2	18.7	990	
5/27/2008	926	0.0	1.46	8.5	0.046		74.9	18.7	1007	
6/4/2008	927	0.0	1.28	8.5	0.10		64.6	25.2	1002	
6/12/2008	1224	0.0	1.28	8.5	0.10		20.6	43.2	1003	
6/20/2008	1052	0.0	1.20	8.0	0.046		32.0	42.0	1005	
6/25/2008	1106	0.0	1.20	8.0	0.10		54.7	30.8	1005	
7/2/2008	1210	0.0	1.20	8.0	0.10		44.5	36.8	1004	
7/7/2008	1157	0.0	1.08	7.5	0.1		45.1	36.6	998	

Aerojet GEDIT - Injection Test Input

Phase II Piezometer Monitoring Data

Well ID P3

Depth 48

Date	Time	Well or Injection Gas Sample						Well	Ambient Air	
		O ₂ (%)	CO ₂ (%)	Propane (%)	H ₂ (%)	He (ppm)	RH (%)	Pressure (in wc)	Temperature (C°)	Barometric pressure (mbar)
7/18/2008	1124	0.0	1.18	7.5	0.046		84.4		26.9	
7/24/2008	1039	0.0	1.18	7.5	0.100		70.0		27.5	1005
7/31/2008	1034	0.0	1.24	7.5	0.100		70.8		26.3	1003
8/7/2008	912	0.0	1.24	7.5	0.22		87.8		20.8	1004
8/12/2008	1016	0.0	1.16	7.5	0.10		52.6		28.6	1002
Optimization Test #8 (100 cfh of 100% Propane to P4-18, & P4-28 (50 cfh to each point)										
9/8/2008	0905 Test Start									
9/8/2008	1110	0.0	1.12	22.5	0.022					999
9/15/2008	934	0.0	2.52	30	0.005		46.9		27.2	1007
9/29/2008	1001	0.0	1.58	30	0.005		52.6		23.0	1006
10/13/2008	1220	0.0	1.50	30	0.010		52.0		26.6	1017
10/20/2008	1147	0.0	1.60	30	0.005		58.6		27.1	1013
11/5/2008	1337	0.0	1.08	30	0.005		79.8		19.8	1016
11/17/2008	1132	0.0	1.10	30	0.010		67.3		25.9	1014
12/1/2008	1103	0.0	1.16	30	0.005		66.3		20.7	1014

Aerojet GEDIT - Injection Test Input

Phase II Piezometer Monitoring Data

Well ID P4

Depth 18

Date	Time	Well or Injection Gas Sample							Well	Ambient Air	
		O ₂ (%)	CO ₂ (%)	Propane (%)	H ₂ (%)	He (ppm)	RH (%)	Pressure (in wc)	Temperature (C°)	Barometric pressure (mbar)	
12/12/2007	1240	18.8	0	0	0.002	50,000	84.2	0.02	12.6	1020	
12/12/2007	1532							0.16			
12/12/2007	1550							0.18			
12/12/2007	1622	5.60				4x10 ³					
12/12/2007	1629	6.20				4x10 ³					
12/12/2007	1638	5.4				1x10 ²					
12/13/2007	756	9.0	0	0	0.002	2x10 ⁴	90.3		-0.2	1016	
12/13/2007	835	5.2	0	0	0.46	7x10 ³				1016	
12/13/2007	924	12.0	0	0	5.5		65.1		9.9	1016	
12/13/2007	1150	12.8	0	0			86.1		13.3		
12/13/2007	1200	Discovered leak in O2 - all O2 data for 12/13/07 before 1200 invalid									
12/13/2007	1201	0.3	0	0			87.9		14.5		
12/13/2007	1314							0.16			
12/13/2007	1322	0.2	0	0	7.9		67.8		18.1	1014	
12/13/2007	1431	0	0	0.02	8.5		78.6		15.9	1013	
12/13/2007	1512	0	0	0.46	2.2		78.4		14.5	1013	
12/13/2007	1546	0	0	0.48	1.4		76.4		12.9	1013	
12/14/2007	808	0.9	0	0.08	0.81		78.1	0.02	2.5	1016	
12/21/2007	1102	13.5	0.06	0.02	0.46		61.8	0.02	NA	1013	
12/21/2007	1338	12.6	0	0.02	0.46		64.7		15.9	1012	
12/26/2007	1210	13.8	0.04	0	0.022		70	0.07	14.3	1017	
12/26/2007	1416	15.3	0	0.02	0.22		77.6		13.8	1015	
12/26/2007	1432	15.5	0	0.02	0.22		76		13.1	1015	
12/26/2007	1442	15.6	0	0.02	0.22		77.4		13.3	1013	
12/26/2007	1455	15.7	0	0.02	0.22		82.3		11.7	1013	
12/26/2007	1537	12.5	0	0.02	0.76		82.9		11.3	1015	

Aerojet GEDIT - Injection Test Input

Phase II Piezometer Monitoring Data

Well ID P4

Depth 18

Date	Time	Well or Injection Gas Sample							Well	Ambient Air
		O ₂ (%)	CO ₂ (%)	Propane (%)	H ₂ (%)	He (ppm)	RH (%)	Pressure (in wc)	Temperature (C°)	Barometric pressure (mbar)
12/26/2007	1616	11.4	0	0.02	1.1		82.9	0.06	9.9	1015
12/27/2007	931	1.4	0	0	8.3		71	0.04	5.2	1017
12/27/2007	1234	1.2	0	0	8.7		75.1		8.5	1017
12/27/2007	1409	1	0	0	9.1		82.1		9.5	1017
12/27/2007	1529	1	0	0	9.2		83.1	0.01	7.9	1017
1/2/2008	947	0.6	0	0	0.22		59.2	0.04	10.7	1012

Tracer Test #1 (10 cfm to INJ2, ~7% H2)										
1/21/2008	1046 Test start									
1/21/2008	1107	1.7	0	0	0.67		88.8	0.00	7.8	1008
1/21/2008	1125	1.7	0	0	0.67		83.4		9.8	1008
1/21/2008	1156	1.6	0	0	0.64		88.9		9.8	1007
1/21/2008	1242	1.4	0	0	1.0		76.7	0.06	10.1	1006
1/21/2008	1434	1.5	0	0	1.7		80.1	0.08	10.4	1006
1/21/2008	1600	1.3	0	0	2.6		85.2		10.0	1006
1/22/2008	914	1.1	0	0	6.0		80.7	0.04	7.4	1011
1/22/2008	1347	0.9	0	0	6.2		91.1		8.1	1009
1/23/2008	951	1.0	0	0	6.2		78.8	0.10	9.3	1008
1/23/2008	1213*	0.8								

Aerojet GEDIT - Injection Test Input

Phase II Piezometer Monitoring Data

Well ID P4

Depth 18

Date	Time	Well or Injection Gas Sample						Well	Ambient Air
		O ₂ (%)	CO ₂ (%)	Propane (%)	H ₂ (%)	He (ppm)	RH (%)	Pressure (in wc)	Temperature (C°)

Tracer Test #2 (20 cfm to INJ2, ~8% H2)										
1/18/2008	1120									
	Test start									
1/18/2008	1127	1.6	0	0	0.54		88.7		12.4	1015
1/18/2008	1146	1.5	0	0	0.52		95.5		12.9	1015
1/18/2008	1155	1.5	0	0	0.22		97.3		13.1	1015
1/18/2008	1209	1.5	0	0	0.22		88.1	0.03	13.0	1015
1/18/2008	1220	1.4	0	0	0.22		88.4		13.4	1015
1/18/2008	1320	1.2	0	0	1.9		81.2		15.8	1014
1/18/2008	1518	1.3	0	0	4.2		74.7	0.02	17.1	1014
1/19/2008	945	0.8	0.04	0	9.8		62.1	0.05	13.0	1019
1/19/2008	1054*	0.8	0	0	9.4		57.7		16.2	1019

Tracer Test #3 (30 cfm to INJ2, ~4% H2)										
1/30/2008	1036									
	Test start									
1/30/2008	1053	0.0	0	0	0.75		88.9	0.04	9.8	1020
1/30/2008	1204	0.0	0	0	1.8		91.8		10.5	1019
1/30/2008	1409	0.0	0	0	3.5		83.4	0.17	12.5	1018
1/31/2008	926	0.1	0	0	4.1		89.5	0.12	7.8	1019
1/31/2008	1123	0	0	0	3.6		83.7		9.6	1018
1/31/2008	1320	0	0	0	3.4		84.2	0.20	8.7	1017
1/31/2008	1435									
1/31/2008	1458	0.1	0		3.4		87.5	0.06	8.2	1014
1/31/2008	1557	0	0	0	3.4		84.3		8.2	1014

Aerojet GEDIT - Injection Test Input

Phase II Piezometer Monitoring Data

Well ID P4

Depth 18

Date	Time	Well or Injection Gas Sample						Well	Ambient Air	
		O ₂ (%)	CO ₂ (%)	Propane (%)	H ₂ (%)	He (ppm)	RH (%)	Pressure (in wc)	Temperature (C°)	Barometric pressure (mbar)
Tracer Test #4 (60 cfm to INJ2, ~7% H2)										
1/28/2008	1236	Test start								
1/28/2008	1244	4.7	0.04	0	0.010			96.3	10.5	1010
1/28/2008	1259	2.8	0.02	0	0.046			95.9	10.6	1010
1/28/2008	1339	0.8	0.02	0	3.2		0.14	93.0	12.3	1010
1/28/2008	1450	0.7	0	0	4.4			80.9	12.9	1011
1/28/2008	1536	0.5	0	0	4.7		0.16	83.5	10.2	1011
1/29/2008	745	0	0	0	7.1		0.15	80.7	5.5	1016
1/29/2008	1008*	0			6.4					
Tracer Test #5 (90 cfm to INJ2, ~3% H2)										
2/5/2008	1015	Test start								
2/5/2008	1019	0.4	0	0	0.046		0.20	75.8	8.6	1019
2/5/2008	1118	0.0	0	0	2.3			83.7	10.7	1019
2/5/2008	1327	0.0	0	0	3.6		0.20	87.1	12.3	1019
2/5/2008	1456	0.0	0	0	3.4			80.8	14.3	1019
2/5/2008	1542	0.0	0	0	3.3			66.4	17.0	1018
Tracer Test #6 (30 cfm total; 10 cfm to each INJ1, 2, and 3; ~8% H2)										
2/7/2008	1500	Test start								
2/7/2008	1519	0.0	0.02	0	0.59			51.1	21.0	1016
2/7/2008	1610	0.0	0	0	0.54			45.8	22.5	1016
2/8/2008	956	0.0	0	0	8.4			62.2	15.1	1017
2/8/2008	1054	0.0	0	0	8.1			86.4	11.0	1017

Aerojet GEDIT - Injection Test Input

Phase II Piezometer Monitoring Data

Well ID P4

Depth 18

Date	Time	Well or Injection Gas Sample						Well	Ambient Air	
		O ₂ (%)	CO ₂ (%)	Propane (%)	H ₂ (%)	He (ppm)	RH (%)	Pressure (in wc)	Temperature (C°)	Barometric pressure (mbar)
Tracer Test #7 (60 cfm total; 20 cfm to each INJ1, 2, and 3, ~5% H2)										
1/17/2008	900	Test start								
1/17/2008	929	14.2	0	0	0.22		90.8	0.02	4.8	1015
1/17/2008	936	14.3	0	0	0.22		89.4		5.2	1015
1/17/2008	958	14.5	0	0	0.22		85.2		7.3	1015
1/17/2008	1058	13.1	0	0	0.66		87.5	0.02	8.7	1015
1/17/2008	1200	11.2	0	0	2.0		91.6		10.1	1015
1/17/2008	1331	8.1	0	0	3.4		96.6		11.9	1013
1/17/2008	1502	5.8	0	0	4.5		97.1	0.05	13.5	1012
Tracer Test #8 (90 cfm total; 30 cfm each to INJ1, 2, and 3; ~4.5% H2)										
2/6/2008	1000	Test start								
2/6/2008	1021	0.0	0	0	0.61		82.1	0.18	12.1	1020
2/6/2008	1127	0.0	0	0	1.0		82.3		12.3	1020
2/6/2008	1234	0.0	0	0	2.2		80.2		13.6	1019
2/6/2008	1417	0.0	0	0	3.7		74.0	0.25	16.0	1017
2/6/2008	1526	0.0	0	0	3.8		68.7		16.3	1017
2/6/2008	1618	0.0	0	0	3.9		66.9		16.9	1017

Aerojet GEDIT - Injection Test Input

Phase II Piezometer Monitoring Data

Well ID P4

Depth 18

Date	Time	Well or Injection Gas Sample							Well	Ambient Air
		O ₂ (%)	CO ₂ (%)	Propane (%)	H ₂ (%)	He (ppm)	RH (%)	Pressure (in wc)	Temperature (C°)	Barometric pressure (mbar)
Optimization Test #1 (90 cfm to INJ2 for 4 hours then shut down; ~88% N2, 10% H2, 1% CO2 & LPG)										
2/20/2008	1118	2.3	0.04	0	0.022		70.5		15.9	1010
2/20/2008	1206 Test start									
2/20/2008	1516	0.8	0.00	0.8	11		33		29.7	1008
2/20/2008	1606 Test End									
2/20/2008	1610	0.5	0.00	0.9	9.7		44.6		23.6	1008
2/21/2008	904	0.2	0.04	0.42	1.9		75.4		11.1	1005
2/22/2008	1021	0.8	0.08	0.16	0.022		81.7		10.4	1003
2/25/2008	1640	2.8	0.12	0.14	0.01		47.2		22.9	1017
Optimization Test #2 (30 cfm to INJ2 for 12 hours then shut down; ~88% N2, 10% H2, 1% CO2 & LPG)										
2/25/2008	1845 Test Start									
2/26/2008	653 Test End									
2/26/2008	656	0.6	0.22	0.6	6.7		91.2		2.7	1017
2/27/2008	1522	0.1	0.1	0.36	0.22		53.2		31.5	1010
2/28/2008	1038	0.2	0.06	0.32	0.022		84.2		15.7	1008
Optimization Test #3A (1 cfm to INJ2; ~88% N2, 10% H2, 1% CO2 & LPG)										
2/29/2008	1319 Test Start									
2/29/2008	1409	1.4	0.00	0.36	0.046		51.5		23	1009
2/29/2008	1511	1.9	0	0.36	0.01		63.5		23.6	1009
3/3/2008	1031	0.6	0	0.6	3.3		72.4		14.7	1019
3/3/2008	1130 Test End									

Aerojet GEDIT - Injection Test Input

Phase II Piezometer Monitoring Data

Well ID P4

Depth 18

Date	Time	Well or Injection Gas Sample						Well	Ambient Air
		O ₂ (%)	CO ₂ (%)	Propane (%)	H ₂ (%)	He (ppm)	RH (%)	Pressure (in wc)	Temperature (C°)
Optimization Test #3B (1 cfm to INJ1, INJ2 & INJ3; ~88% N2, 10% H2, 1% CO2 & LPG)									
3/3/2008	1130	Test Start							
3/4/2008	919	0.4	0.04	0.64	1.8		82.3	10.8	1013
3/7/2008	1042	0.4	0	0.7	2		65.1	19	1018
3/7/2008	1306	Test End							
Optimization Test #3C (90 cfm to INJ1, INJ2 & INJ3 for 15 minutes then shut down; ~79% N2, 10% H2 & LPG, 1% CO2)									
3/7/2008	1306	Start Pulse							
3/7/2008	1321	End Pulse							
3/7/2008	1327	1.6	0	0.66	3.9		52.5	23.7	1016
3/7/2008	1400	1.6	0	0.66	3.4		57.9	22.4	1016
3/10/2008	1031	1.2	0.04	0.68	0.22		81.9	15.7	1016
Optimization Test #4 (2, 45-minutes pulses; daily 15-minutes pulses w/30cfh constant flow)									
3/10/2008	1236	3.2	0.08	0.68	0.046		65.5	20.7	1016
3/10/2008	1257	5.6	0.08	0.66	0.022				
3/10/2008	1333	6.6	0.14	0.58	0.046		59.4	22.1	1016
3/10/2008	1347	End pulse							
3/10/2008	1402	6.7	0.10	0.6	0.022		53.2	22.6	1015
3/11/2008	904	3.8	0.08	1.12	0.046		60.3	15.6	1017
3/12/2008	952	0.0	0.06	2.5	0.8		84.5	12	1014
3/13/2008	908	0.0	0.04	3.5	1.5		84.1	13.6	1011
3/14/2008	1134	0.8	0.08	2	0.022		92	13.3	1013
3/14/2008	1209	0.4	0.04	3.5	1.8		81	15	1012
3/15/2008	1116	1.6	0.12	1.26	0.022		82.9	11	1009
3/16/2008	1105	2.4	0.04	0.82	0.022		68.2	15	1009
3/17/2008	917	2.7	0.14	0.67	0.022		76.9	8.3	1014

Aerojet GEDIT - Injection Test Input

Phase II Piezometer Monitoring Data

Well ID P4

Depth 18

Date	Time	Well or Injection Gas Sample							Well	Ambient Air
		O ₂ (%)	CO ₂ (%)	Propane (%)	H ₂ (%)	He (ppm)	RH (%)	Pressure (in wc)	Temperature (C°)	Barometric pressure (mbar)
Optimization Test #5 (20 cfm to INJ2 for 125 minutes while maintaing 30 cfm the rest of the time; ~80% N2, 10% H2 & LPG)										
3/17/2008	1037	Start Test								
3/17/2008	1247	4.7	0.02	3.5	3.9		74.3	17.6	1014	
3/8/2008	936	2.2	0.10	2.5	0.046		80.4	12.4	1016	
3/19/2008	952	0.9	0.12	2.5	0.22		88.5	11.7	1013	
3/20/2008	936	1.0	0.16	2	0.01		87.1	8.6	1016	
3/20/2008	~1100	End Test								
Optimization Test #6 (50 cfm to P4-18 & P4-28; ~80% N2, 10% H2 & LPG)										
3/20/2008	1330	Start Test								
3/28/2008	1034*	0.0	0.0	15.0	12.0		Measured at injection point			
3/31/2008	1015	0.4	0	15.5	8.2		Measured w/tedlar bag		1013	
3/31/2008	1035		0	11	8		Measured w/tedlar bag		1013	
4/2/2008	1125	0.0	0	14.0	4.2		Measured at injection point		1008	
4/2/2008	1131	0.0	0	10.0	10.0		Measured at injection point		1008	

Aerojet GEDIT - Injection Test Input

Phase II Piezometer Monitoring Data

Well ID P4

Depth 18

Date	Time	Well or Injection Gas Sample						Well	Ambient Air
		O ₂ (%)	CO ₂ (%)	Propane (%)	H ₂ (%)	He (ppm)	RH (%)	Pressure (in wc)	Temperature (C°)
Optimization Test #7 (20 cfh to P4-18, --28, -38 (60 cfh total); ~80% N2, 10% H2 & LPG)									
4/2/2008	1233	Start Test							
4/4/2008									1013
Optimization Test #7B (30 cfh to P4-18, & P4-28 (60 cfh total); ~80% N2, 10% H2 & LPG)									
4/7/2008	1458	Start Test							
Optimization Test #7C (50 cfh to P4-18, & P4-28 (100 cfh total); ~79% N2, 10% H2 & LPG, 1% CO2)									
4/10/2009	1121	Start Test							
Optimization Test #8 (100 cfh of 100% Propane to P4-18, & P4-28 (50 cfh to each point))									
9/8/2008	0905	Test Start							
9/8/2008									999

Aerojet GEDIT - Injection Test Input

Phase II Piezometer Monitoring Data

Well ID P4

Depth 28

Date	Time	Well or Injection Gas Sample						Well	Ambient Air		
		O ₂ (%)	CO ₂ (%)	Propane (%)	H ₂ (%)	He (ppm)	RH (%)	Pressure (in wc)	Temperature (C°)	Barometric pressure (mbar)	
12/12/2007	1242	19.4	0.18	0	0.002	50,000	83.0	0.01	12.5	1020	
12/12/2007	1532							0.20			
12/12/2007	1551							0.22			
12/12/2007	1622	1.1				1X10 ²					
12/12/2007	1630	0.8				1X10 ²					
12/12/2007	1639	0.5				3x10 ³					
12/13/2007	801	8.4	0.06	0	0.002	2X10 ⁴	89.6		0.3	1016	
12/13/2007	833	4.2	0.00	0	1.6	5X10 ³	75.3		4.0	1016	
12/13/2007	926	10.9	0	0	7.7		67.3		9.6	1016	
12/13/2007	1152	11.8	0	0			88.2		13.7		
12/13/2007	1200	Discovered leak in O2 - all O2 data for 12/13/07 before 1200 invalid									
12/13/2007	1202	0	0	0			85.1		15.0		
12/13/2007	1315							0.20			
12/13/2007	1323	0	0	0	8.3		71.9		17.7	1014	
12/13/2007	1428	0.0	0.1	0.24	4.4		78.6		15.7	1013	
12/13/2007	1513	0	0.36	0.52	0.54		82.3		14.6	1013	
12/13/2007	1547	0	0.46	0.52			78.7		12.8	1013	
12/14/2007	809	0	0.1	0	0.5		77.1	0.01	2.8	1016	
12/21/2007	1108	14.6	0.46	0.02	0.46		62.5	0.01	11.1	1013	
12/21/2007	1342	14.8	0.42	0.02	0.46		69.3		14.9	1012	

Aerojet GEDIT - Injection Test Input

Phase II Piezometer Monitoring Data

Well ID P4

Depth 28

Date	Time	Well or Injection Gas Sample						Well	Ambient Air	
		O ₂ (%)	CO ₂ (%)	Propane (%)	H ₂ (%)	He (ppm)	RH (%)	Pressure (in wc)	Temperature (C°)	Barometric pressure (mbar)
12/26/2007	1220	17.6	0.44	0	0.22		70.6	0.01	14.8	1017
12/26/2007	1412	13.4	0.46	0.02	0.46		76.4		14.2	1015
12/26/2007	1431	9.3	0.42	0.02	0.46		74.7		13.3	1015
12/26/2007	1441	8.1	0.42	0	0.74		77.7		13.3	1015
12/26/2007	1454	6.8	0.42	0	1.9		78.8		12.1	1013
12/26/2007	1540	3.4	0.36	0	5.6		83.9		11.2	1015
12/26/2007	1616	1.9	0.34	0	7		86	0.04	9.7	1015
12/27/2007	934	0.1	0	0	9.1		78.7	0.02	4.8	1017
12/27/2007	1236	0.1	0	0	9		77.8		8.7	1017
12/27/2007	1411	0.1	0	0	9.3		84		9.2	1017
12/27/2007	1532	0.1	0	0	9.6		86.8	0	7.8	1017
1/2/2008	949	0.1	0	0	0.46		62.2	0.03	10.7	1012

Tracer Test #1 (10 cfm to INJ2, ~7% H2)										
1/21/2008	1046 Test start									
1/21/2008	1106	0.9	0	0	0.70		87.6	0.03	7.8	1008
1/21/2008	1124	0.9	0	0	1.7		84.2		9.8	1008
1/21/2008	1155	0.9	0	0	3.6		90.1		9.8	1007
1/21/2008	1243	0.8	0	0	5.0		84.5	0.10	10.1	1006
1/21/2008	1435	0.9	0	0	5.7		81.5	0.10	10.7	1006

Aerojet GEDIT - Injection Test Input

Phase II Piezometer Monitoring Data

Well ID P4

Depth 28

Date	Time	Well or Injection Gas Sample						Well	Ambient Air	
		O ₂ (%)	CO ₂ (%)	Propane (%)	H ₂ (%)	He (ppm)	RH (%)	Pressure (in wc)	Temperature (C°)	Barometric pressure (mbar)
1/21/2008	1601	0.8	0	0	6.0		86.4		10.0	1006
1/22/2008	915	0.7	0	0	7.0		81.7	0.04	7.4	1011
1/22/2008	1348	0.6	0	0	6.9		91.3		8.4	1009
1/23/2008	952	0.8	0	0	6.7		79.7	0.08	9.4	1008
1/23/2008	1214*	0.8								

Tracer Test #2 (20 cfm to INJ2, ~8% H2)										
1/18/2008	1120 Test start									
1/18/2008	1128	0.9	0	0	0.10		91.1		12.4	1015
1/18/2008	1145	0.8	0	0	2.4		94.0		12.9	1015
1/18/2008	1156	0.8	0	0	3.7		96.9		13.0	1015
1/18/2008	1210	1.0	0	0	4.9		94.3	0.01	13.2	1015
1/18/2008	1221	0.7	0	0	5.7		92.7		13.4	1015
1/18/2008	1322	0.6	0	0	6.8		86.8		15.8	1014
1/18/2008	1519	0.8	0	0	7.0		78.8	0.01	17.1	1014
1/19/2008	947	0.8	0	0	7.8		65.0	0.03	12.3	1019
1/19/2008	1057*	0.8	0	0	6.4		60.7		15.9	1019

Aerojet GEDIT - Injection Test Input

Phase II Piezometer Monitoring Data

Well ID P4

Depth 28

Date	Time	Well or Injection Gas Sample						Well	Ambient Air
		O ₂ (%)	CO ₂ (%)	Propane (%)	H ₂ (%)	He (ppm)	RH (%)	Pressure (in wc)	Temperature (C°)

Tracer Test #3 (30 cfm to INJ2, ~4% H2)										
1/30/2008	1036	Test start								
1/30/2008	1052	0.0	0	0	2.2		87.8	0.11	9.8	1020
1/30/2008	1205	0.0	0	0	4.2		93.3		10.6	1019
1/30/2008	1611	0.0	0	0	4.7		90.4	0.14	12.5	1018
1/31/2008	927	0.0	0	0	4.1		93.2	0.15	7.8	1019
1/31/2008	1123	0	0	0	3.7		87.5		9.6	1018
1/31/2008	1322	0	0	0	3.5		87.1	0.18	8.9	1017
1/31/2008	1435									
1/31/2008	1459	0	0	0	3.7		89.4	0.12	8.2	1014
1/31/2008	1558	0	0	0	3.8		87.5		8.2	1014

Tracer Test #4 (60 cfm to INJ2, ~7% H2)										
1/28/2008	1236	Test start								
1/28/2008	1246	2.4	0	0	1.2		95.8		10.5	1010
1/28/2008	1258	1.0	0	0	3.6		94.2		10.5	1010
1/28/2008	1345	0.0	0	0	5.9		86.9	0.24	11.9	1010
1/28/2008	1349*	0.0	0	0	5.9					
1/28/2008	1452	0.0	0	0	6.0		80.9		12.8	1011

Aerojet GEDIT - Injection Test Input

Phase II Piezometer Monitoring Data

Well ID P4

Depth 28

Date	Time	Well or Injection Gas Sample						Well	Ambient Air	
		O ₂ (%)	CO ₂ (%)	Propane (%)	H ₂ (%)	He (ppm)	RH (%)	Pressure (in wc)	Temperature (C°)	Barometric pressure (mbar)
1/28/2008	1539	0.0	0		6.0		86.9	0.26	10.2	1011
1/29/2008	746	0.0	0	0	7.2		82.9	0.22	5.4	1016
1/29/2008	1009*	0.0			6.6					

Tracer Test #5 (90 cfm to INJ2, ~3% H2)										
2/5/2008	1015 Test start									
2/5/2008	1021	0.0	0	0	2.1		79.6	0.27	8.7	1019
2/5/2008	1119	0.0	0	0	3.3		87.3		10.3	1019
2/5/2008	1328	0.0	0	0	4.0		91.6	0.29	12.3	1019
2/5/2008	1457	0.0	0	0	3.7		86.3		14.3	1019
2/5/2008	1543	0.0	0	0	3.5		69.0		17.3	1019

Tracer Test #6 (30 cfm total; 10 cfm to each INJ1, 2, and 3; ~8% H2)										
2/7/2008	1500 Test start									
2/7/2008	1520	0.0	0	0	0.046		55.0		21.0	1016
2/7/2008	1611	0.0	0	0	1.9		50.3		22.3	1016
2/8/2008	957	0.0	0	0	8.9		61.0		14.6	1017

Aerojet GEDIT - Injection Test Input

Phase II Piezometer Monitoring Data

Well ID P4

Depth 28

Date	Time	Well or Injection Gas Sample						Well	Ambient Air
		O ₂ (%)	CO ₂ (%)	Propane (%)	H ₂ (%)	He (ppm)	RH (%)	Pressure (in wc)	Temperature (C°)

Tracer Test #7 (60 cfm total; 20 cfm to each INJ1, 2, and 3, ~5% H2)										
1/17/2008	900	Test start								
1/17/2008	912	16.5	0.30	0	0.22		90.5	0.02	3.1	1015
1/17/2008	927	12.5	0.34	0	0.5		90.8		4.6	1015
1/17/2008	933	8.3	0.34	0	1.2		90.4		5.0	1015
1/17/2008	1000	2.4	0.24	0	3.7		86.8		7.2	1015
1/17/2008	1105	1.3	0.06	0	4.6		93.7	0.04	9.0	1015
1/17/2008	1202	1.2	0	0	4.9		95.0		10.1	1015
1/17/2008	1333	0.8	0.10	0	5.4		98.2		12.1	1013
1/17/2008	1504	0.7	0.06	0	5.8		98.9	0.04	14.0	1012

Tracer Test #8 (90 cfm total; 30 cfm each to INJ1, 2, and 3; ~4.5% H2)										
2/6/2008	1000	Test start								
2/6/2008	1022	0.0	0	0	1.2		80.8	0.24	12.0	1020
2/6/2008	1128	0.0	0	0	4.1		83.7		12.3	1020
2/6/2008	1235	0.0	0	0	4.2		80.6		13.7	1019
2/6/2008	1419	0.0	0	0	4.9		74.9	0.21	16.1	1017
2/6/2008	1527	0.0	0	0	4.7		70.2		16.6	1017

Aerojet GEDIT - Injection Test Input

Phase II Piezometer Monitoring Data

Well ID P4

Depth 28

Date	Time	Well or Injection Gas Sample						Well	Ambient Air
		O ₂ (%)	CO ₂ (%)	Propane (%)	H ₂ (%)	He (ppm)	RH (%)	Pressure (in wc)	Temperature (C°)
Optimization Test #1 (90 cfm to INJ2 for 4 hours then shut down; ~88% N2, 10% H2, 1% CO2 & LPG)									
2/20/2008	1119	6.6	0.00	0	0.046		72.4	15.8	1010
2/20/2008	1206 Test start								
2/20/2008	1517	0.0	0.94	1.02	12		37.5	29.6	1008
2/20/2008	1606 Test End								
2/20/2008	1611	0.0	0.78	1.06	9.6		48.4	23.3	1008
2/21/2008	905	2.0	0.58	0.74	7.7		75.9	11	1005
2/22/2008	1025	5.8	0.48	0.38	2.7		84.7	10.1	1003
Optimization Test #2 (30 cfm to INJ2 for 12 hours then shut down; ~88% N2, 10% H2, 1% CO2 & LPG)									
2/25/2008	1845 Test Start								
2/26/2008	653 Test End								
2/26/2008	656	0.0	2.24	0.5	7.4		91.6	2.7	1017
2/27/2008	1523	4.0	1.34	0.34	2.6		48.3	31.9	1010
2/28/2008	1040	6.5	1.1	0.26	1.3		87.9	15.7	1008
Optimization Test #3A (1 cfm to INJ2; ~88% N2, 10% H2, 1% CO2 & LPG)									
2/29/2008	1319 Test Start								
2/29/2008	1410	6.8	0.80	0.26	0.85		60.2	23.1	1009
2/29/2008	1513	6.2	0.82	0.26	0.85		61.7	23.4	1009

Aerojet GEDIT - Injection Test Input

Phase II Piezometer Monitoring Data

Well ID P4

Depth 28

Date	Time	Well or Injection Gas Sample						Well	Ambient Air
		O ₂ (%)	CO ₂ (%)	Propane (%)	H ₂ (%)	He (ppm)	RH (%)	Pressure (in wc)	Temperature (C°)
3/3/2008	1033	5.1	0.86	0.36	4.3		77.7	14.8	1019
3/3/2008	1130 Test End								
Optimization Test #3B (1 cfm to INJ1, INJ2 & INJ3; ~88% N2, 10% H2, 1% CO2 & LPG)									
3/3/2008	1130 Test Start								
3/4/2008	920	9.2	0.9	0.28	2.1		85.8	10.1	1013
3/7/2008	1043	8.3	0.48	0.28	2.5		67.4	19	1018
3/7/2008	1306 Test End								
Optimization Test #3C (90 cfm to INJ1, INJ2 & INJ3 for 15 minutes then shut down; ~79% N2, 10% H2 & LPG, 1% CO2)									
3/7/2008	1306 Start Pulse								
3/7/2008	1321 End Pulse								
3/7/2008	1330	9.5	0.42	0.2	0.98		55.2	23.5	1016
3/7/2008	1401	9.5	0.44	0.2	1.2				1016
3/10/2008	1032	8.7	0.48	0.3	0.046		84.7	15.7	1016
Optimization Test #4 (2, 45-minutes pulses; daily 15-minutes pulses w/30cfh constant flow)									
3/10/2008	1237	8.9	0.54	0.28	0.022		66	20.7	1016
3/10/2008	1256	9.7	0.52	0.24	0.046				
3/10/2008	1315	6.4	0.64	2.5	3.4		64.6	21.4	1016
3/10/2008	1339	2.6	0.84	2	8.7				

Aerojet GEDIT - Injection Test Input

Phase II Piezometer Monitoring Data

Well ID P4

Depth 28

Date	Time	Well or Injection Gas Sample						Well	Ambient Air	
		O ₂ (%)	CO ₂ (%)	Propane (%)	H ₂ (%)	He (ppm)	RH (%)	Pressure (in wc)	Temperature (C°)	Barometric pressure (mbar)
3/10/2008	1347	End pulse								
3/10/2008	1403	1.6	0.82	6	9.6		57	22.7	1015	
3/11/2008	905	2.2	0.82	4	4.9		64.3	15.3	1018	
3/12/2008	953	4.7	0.88	3.5	4.3		88.3	12.2	1014	
3/13/2008	909	5.9	0.70	3.5	3.5		87.3	13.6	1011	
3/14/2008	1134	6.6	0.64	2	1.7		91.7	13.4	1013	
3/14/2008	1208	3.4	0.78	2	7.2				1012	
3/14/2008	1229	2.9	0.76	2	8.5					
3/15/2008	1117	10.7	0.68	1.18	0.67		89	11	1009	
3/16/2008	1106	11.1	0.46	1.16	0.5		77.2	14.9	1009	
3/17/2008	918	9.5	0.60	3	1.7		84	8.5	1014	

Optimization Test #5 (20 cfm to INJ2 for 125 minutes while maintaing 30 cfh the rest of the time; ~80% N2, 10% H2 & LPG)										
3/17/2008	1037	Start Test								
3/17/2008	1248	0.3	0.20	9.5	9.8		81.8	17.5	1014	
3/18/2008	936	3.6	0.32	10.5	6.7		85.4	12.6	1016	
3/19/2008	954	5.8	0.30	6	3		90.7	11.8	1013	
3/20/2008	938	8.3	0.34	3.5	1.7		90.1	8.8	1016	
3/20/2008	~1100	End Test								

Aerojet GEDIT - Injection Test Input

Phase II Piezometer Monitoring Data

Well ID P4

Depth 28

Date	Time	Well or Injection Gas Sample						Well	Ambient Air
		O ₂ (%)	CO ₂ (%)	Propane (%)	H ₂ (%)	He (ppm)	RH (%)	Pressure (in wc)	Temperature (C°)
Optimization Test #6 (50 cfh to P4-18 & P4-28; ~80% N ₂ , 10% H ₂ & LPG)									
3/20/2008	1330								
3/28/2008	1034*	0.0	0.0	15.0	12.0	concentrations of injected gasses			
3/31/2008									1013
4/2/2008									1008
Optimization Test #7 (20 cfh to P4-18, --28, -38 (60 cfh total); ~80% N ₂ , 10% H ₂ & LPG)									
4/2/2008	1233								
4/4/2008									1013
Optimization Test #7B (30 cfh to P4-18, & P4-28 (60 cfh total); ~80% N ₂ , 10% H ₂ & LPG)									
4/7/2008	1458								
Optimization Test #7C (50 cfh to P4-18, & P4-28 (100 cfh total); ~79% N ₂ , 10% H ₂ & LPG, 1% CO ₂)									
4/10/2009	1121								
Optimization Test #8 (100 cfh of 100% Propane to P4-18, & P4-28 (50 cfh to each point))									
9/8/2008	0905								
9/8/2008									999

Aerojet GEDIT - Injection Test Input

Phase II Piezometer Monitoring Data

Well ID P4

Depth 38

Date	Time	Well or Injection Gas Sample							Well	Ambient Air	
		O ₂ (%)	CO ₂ (%)	Propane (%)	H ₂ (%)	He (ppm)	RH (%)	Pressure (in wc)	Temperature (C°)	Barometric pressure (mbar)	
12/12/2007	1244	19.3	0.36	0	0.002	70,000	85.1	0.02	12.4	1020	
12/12/2007	1532							0.44			
12/12/2007	1551							0.42			
12/12/2007	1622	0.5				2x10 ⁴					
12/12/2007	1630	0.4				2x10 ⁴					
12/12/2007	1637	0.3				2x10 ⁴					
12/13/2007	759	8.2	0.16	0	0.002	2x10 ⁴	89.2		0.2	1016	
12/13/2007	836	3.8	0.12	0	1.0	2x10 ³	75.9		4.0	1016	
12/13/2007	927	8.8	0	0	6.7		70.0		9.4		
12/13/2007	1200	Discovered leak in O2 - all O2 data for 12/13/07 before 1200 invalid									
12/13/2007	1203	0	0.14	0							
12/13/2007	1315							0.31			
12/13/2007	1324	0	0.14	0	8.3		75.1		17.3	1014	
12/13/2007	1433	0	0.10	0.18	6.2		79.3		16.3	1014	
12/13/2007	1514	0	0.18	0.38	2.6		82.6		14.7	1013	
12/13/2007	1550	0	0.18	0.38			80.1		12.5	1013	
12/14/2007	810	0	0.26	0.12	0.5		73.0	0.02	3.5	1016	
12/21/2007	1111	8.9	0.30	0.08	0.51		59.7	0.03	14.2	1013	
12/21/2007	1344	9.2	0.24	0.08	0.52		75.4		13.9	1012	
12/26/2007	1214	14.2	0.22	0.02	0.22		69.4	0	14.8	1017	

Aerojet GEDIT - Injection Test Input

Phase II Piezometer Monitoring Data

Well ID P4

Depth 38

Date	Time	Well or Injection Gas Sample						Well	Ambient Air	
		O ₂ (%)	CO ₂ (%)	Propane (%)	H ₂ (%)	He (ppm)	RH (%)	Pressure (in wc)	Temperature (C°)	Barometric pressure (mbar)
12/26/2007	1415	14.1	0.22	0.02	0.22		76.7		14	1015
12/26/2007	1435	13.9	0.22	0.04	0.22		78.9		13.1	1015
12/26/2007	1444	13.4	0.24	0.04	0.22		79.8		13.2	1015
12/26/2007	1542	12	0.26	0.04	0.6		84.9		11	1015
12/26/2007	1620	11.3	0.26	0.04	1.3		88.3	0.04	9.6	1015
12/27/2007	936	1.6	0.24	0.02	8.7		80.3	0.02	4.6	1017
12/27/2007	1238	0.9	0.18	0	8.8		78.1		8.9	1017
12/27/2007	1413	0.8	0.14	0	9.2		85.2		9	1017
12/27/2007	1534	0.7	0.14	0	9.4		88.8	0.03	7.7	1017
1/2/2008	950	0.1	0	0	0.22		67.4	0.04	10.7	1012

Tracer Test #1 (10 cfm to INJ2, ~7% H2)										
1/21/2008	1046 Test start									
1/21/2008	1108	1.8	0	0	0.55		87.5	0.04	7.9	1008
1/21/2008	1126	1.7	0	0	0.55		82.2		9.9	1008
1/21/2008	1157	1.8	0	0	0.73		89.6		9.8	1007
1/21/2008	1244	1.7	0	0	0.85		82.5	0.07	10.1	1006
1/21/2008	1436	1.8	0	0	2.8		81.2	0.05	10.4	1006
1/21/2008	1602	1.8	0	0	3.7		85.6		10.0	1006
1/22/2008	917	1.1	0	0	6.7		82.5	0.01	7.4	1011

Aerojet GEDIT - Injection Test Input

Phase II Piezometer Monitoring Data

Well ID P4

Depth 38

Date	Time	Well or Injection Gas Sample						Well	Ambient Air	
		O ₂ (%)	CO ₂ (%)	Propane (%)	H ₂ (%)	He (ppm)	RH (%)	Pressure (in wc)	Temperature (C°)	Barometric pressure (mbar)
1/22/2008	1349	0.7	0	0	6.8		91.2		8.3	1009
1/23/2008	953	0.8	0.02	0	6.8		78.8	0.12	9.3	1007
1/23/2008	1215*	0.7								

Tracer Test #2 (20 cfm to INJ2, ~8% H2)										
1/18/2008	1120 Test start									
1/18/2008	1129	1.4	0.06	0	0.22		80.4		12.3	1015
1/18/2008	1147	1.4	0.06	0	0.10		84.9		12.8	1015
1/18/2008	1157	1.5	0.08	0	0.62		85.8		12.9	1015
1/18/2008	1322	1.4	0.06	0	2.8		73.2		15.7	1014
1/18/2008	1520	1.5	0.04	0	4.4		69.5	0.04	16.9	1014
1/19/2008	948	0.7	0.12	0	9.8		66.8	0.02	11.8	1019
1/19/2008	1059*	0.7	0.08	0	8.9		59.7		15.7	1019

Tracer Test #3 (30 cfm to INJ2, ~4% H2)										
1/30/2008	1036 Test start									
1/30/2008	1054	0.0	0	0	1.1		87.9	0.14	8.7	1020
1/30/2008	1212	0.0	0	0	2.7		81.9		11.3	1019
1/30/2008	1412	0.0	0	0	3.7		83.1	0.16	12.5	1018
1/31/2008	929	0.0	0	0	4.2		92.6	0.15	7.9	1019

Aerojet GEDIT - Injection Test Input

Phase II Piezometer Monitoring Data

Well ID P4

Depth 38

Date	Time	Well or Injection Gas Sample						Well	Ambient Air	
		O ₂ (%)	CO ₂ (%)	Propane (%)	H ₂ (%)	He (ppm)	RH (%)	Pressure (in wc)	Temperature (C°)	Barometric pressure (mbar)
1/31/2008	1124	0	0	0	3.8		86.8		9.6	1018
1/31/2008	1323	0	0	0	3.6		86.4	0.19	8.8	1016
1/31/2008	1435									
1/31/2008	1502	0	0	0	3.7		88.3	0.08	8.2	1014
1/31/2008	1559	0	0	0	3.8		87.0		8.3	1014

Tracer Test #4 (60 cfm to INJ2, ~7% H2)										
1/28/2008	1236 Test start									
1/28/2008	1247	4.7	0.02	0	0.22		96.1		10.4	1010
1/28/2008	1300	4.7	0.02	0	0.22		95.7		10.5	1010
1/28/2008	1346	3.7	0	0	2.7		85.3	0.30	12.0	1010
1/28/2008	1453	2.8	0	0	3.8		81.3		12.8	1011
1/28/2008	1540	2.4	0	0	4.3		86.7	0.31	10.1	1011
1/29/2008	747	0.0	0	0	7.3		84.6	0.30	5.3	1016
1/29/2008	Final O2*	0.0								

Tracer Test #5 (90 cfm to INJ2, ~3% H2)										
2/5/2008	1015 Test start									
2/5/2008	1022	3.3	0	0	0.10		83.1	0.34	8.9	1019
2/5/2008	1120	2.2	0	0	1.5		90.0		10.7	1019

Aerojet GEDIT - Injection Test Input

Phase II Piezometer Monitoring Data

Well ID P4

Depth 38

Date	Time	Well or Injection Gas Sample						Well	Ambient Air	
		O ₂ (%)	CO ₂ (%)	Propane (%)	H ₂ (%)	He (ppm)	RH (%)	Pressure (in wc)	Temperature (C°)	Barometric pressure (mbar)
2/5/2008	1328	0.9	0	0	3.2		92.6	0.30	12.3	1019
2/5/2008	1458	0.4	0	0	3.3		77.3		14.9	1019
2/5/2008	1544	0.3	0	0	3.2		60.6		17.5	1018

Tracer Test #6 (30 cfm total; 10 cfm to each INJ1, 2, and 3; ~8% H2)										
2/7/2008	1500 Test start									
2/7/2008	1521	0.0	0	0	0.64		55.7		20.9	1016
2/7/2008	1613	0.0	0	0	0.68		50.5		21.9	1016
2/8/2008	959	0.0	0	0	5.9		59.3		13.8	1017
2/8/2008	1053	0.0	0	0	5.7		84.9		10.9	1017

Tracer Test #7 (60 cfm total; 20 cfm to each INJ1, 2, and 3, ~5% H2)										
1/17/2008	900 Test start									
1/17/2008	930	13.0	0.08	0	0.22		90.5	0.03	4.9	1015
1/17/2008	1001	13.1	0.04	0	0.22		86.8		7.2	1015
1/17/2008	1108	12.0	0.04	0	0.46		93.3	0.03	9.1	1015
1/17/2008	1204	10.2	0.04	0	1.1		97.2		10.2	1015
1/17/2008	1334	7.5	0.22	0	2.3		98.8		12.3	1013
1/17/2008	1505	5.1	0.22	0	3.4		97.7	0.04	13.8	1012

Aerojet GEDIT - Injection Test Input

Phase II Piezometer Monitoring Data

Well ID P4

Depth 38

Date	Time	Well or Injection Gas Sample						Well	Ambient Air
		O ₂ (%)	CO ₂ (%)	Propane (%)	H ₂ (%)	He (ppm)	RH (%)	Pressure (in wc)	Temperature (C°)

Tracer Test #8 (90 cfm total; 30 cfm each to INJ1, 2, and 3; ~4.5% H2)										
2/6/2008	1000	Test start								
2/6/2008	1023	0.0	0	0	0.71		82.6	0.23	11.9	1020
2/6/2008	1129	0.0	0	0	1.1		82.5		12.3	1020
2/6/2008	1235	0.0	0	0	1.7		80.2		13.7	1019
2/6/2008	1423	0.0	0	0	2.9		69.6	0.20	16.0	1017
2/6/2008	1527	0.0	0	0	3.1		69.3		16.1	1017
2/6/2008	1622	0.0	0	0	3.3		69.4		16.4	1017

Optimization Test #1 (90 cfm to INJ2 for 4 hours then shut down; ~88% N2, 10% H2, 1% CO2 & LPG)										
2/20/2008	1120	7.8	0.00	0	0.046		72.6		15.4	1010
2/20/2008	1206	Test start								
2/20/2008	1518	2.3	0.14	0.68	9.9		33.8		29.8	1008
2/20/2008	1606	Test End								
2/20/2008	1612	1.6	0.16	0.78	9.6		48.6		23.2	1008
2/21/2008	907	3.1	0.04	0.72	8.5		76.7		10.8	1005
2/22/2008	1025	6.7	0.06	0.48	4.1		83.8		10	1003

Aerojet GEDIT - Injection Test Input

Phase II Piezometer Monitoring Data

Well ID P4

Depth 38

Date	Time	Well or Injection Gas Sample						Well	Ambient Air
		O ₂ (%)	CO ₂ (%)	Propane (%)	H ₂ (%)	He (ppm)	RH (%)	Pressure (in wc)	Temperature (C°)
Optimization Test #2 (30 cfm to INJ2 for 12 hours then shut down; ~88% N2, 10% H2, 1% CO2 & LPG)									
2/25/2008	1845 Test Start								
2/26/2008	653 Test End								
2/26/2008	658	1.0	1.36	0.62	7		91.6	2.8	1017
2/27/2008	1525	3.7	0.54	0.34	3.7		43.5	31.9	1009
2/28/2008	1041	5.0	0.56	0.32	2		86.6	15.7	1008
Optimization Test #3A (1 cfm to INJ2; ~88% N2, 10% H2, 1% CO2 & LPG)									
2/29/2008	1319 Test Start								
2/29/2008	1414	7.3	0.50	0.3	0.98		63.6	23	1009
2/29/2008	1514	7.3	0.5	0.3	0.78		60.8	23.2	1009
3/3/2008	1035	7.6	0.6	0.2	0.046		80.6	14.8	1019
3/3/2008	1130 Test End								
Optimization Test #3B (1 cfm to INJ1, INJ2 & INJ3; ~88% N2, 10% H2, 1% CO2 & LPG)									
3/3/2008	1130 Test Start								
3/4/2008	921	8.4	0.72	0.22	0.022		84.2	11.2	1013
3/7/2008	1045	9	0.48	0.18	0.046		71	18.7	1018
3/7/2008	1306 Test End								

Aerojet GEDIT - Injection Test Input

Phase II Piezometer Monitoring Data

Well ID P4

Depth 38

Date	Time	Well or Injection Gas Sample						Well	Ambient Air	
		O ₂ (%)	CO ₂ (%)	Propane (%)	H ₂ (%)	He (ppm)	RH (%)	Pressure (in wc)	Temperature (C°)	Barometric pressure (mbar)
Optimization Test #3C (90 cfm to INJ1, INJ2 & INJ3 for 15 minutes then shut down; ~79% N2, 10% H2 & LPG, 1% CO2)										
3/7/2008	1306	Start Pulse								
3/7/2008	1321	End Pulse								
3/7/2008	1331	8.9	0.44	0.18	0.022		56.2	23.3	1016	
3/10/2008	1041	8.8	0.56	0.42	0.046		82	16.1	1016	
Optimization Test #4 (2, 45-minutes pulses; daily 15-minutes pulses w/30cfh constant flow)										
3/10/2008	1238	8.9	0.64	0.4	0.022		69.7	20.9	1016	
3/10/2008	1342	8.0	0.64	0.96	1.4					
3/10/2008	1347	End pulse								
3/10/2008	1404	7.3	0.62	1.32	2.7		58.2	22.7	1015	
3/11/2008	906	6.1	0.64	2	1.9		64.8	15.1	1018	
3/12/2008	955	6.8	0.58	1.42	0.88		89.2	12.4	1014	
3/13/2008	910	7.0	0.50	1.3	0.5		89.7	13.7	1011	
3/14/2008	1135	7.2	0.52	1.4	0.5		92.1	13.6	1013	
3/14/2008	1210	7.0	0.46	1.4	0.67		81.1	15	1012	
3/15/2008	1120	7.9	0.52	1.3	0.5		90.8	111	1009	
3/16/2008	1107	7.0	0.38	3	1.5		81	14.7	1009	
3/17/2008	919	8.2	0.50	3	0.65		85.8	8.7	1014	

Aerojet GEDIT - Injection Test Input

Phase II Piezometer Monitoring Data

Well ID P4

Depth 38

Date	Time	Well or Injection Gas Sample						Well	Ambient Air
		O ₂ (%)	CO ₂ (%)	Propane (%)	H ₂ (%)	He (ppm)	RH (%)	Pressure (in wc)	Temperature (C°)
Optimization Test #5 (20 cfm to INJ2 for 125 minutes while maintaing 30 cfh the rest of the time; ~80% N2, 10% H2 & LPG)									
3/17/2008	1037	Start Test							
3/17/2008	1250	5.7	0.38	4.5	4.2		84	17.6	1014
3/8/2008	938	4.2	0.46	6	2.7		86.6	12.7	1016
3/19/2008	955	5.1	0.42	5	1.2		90.6	11.9	1013
3/20/2008	939	5.3	0.44	4.5	0.5		87.5	8.9	1016
3/20/2008	~1100	End Test							
Optimization Test #6 (50 cfh to P4-18 & P4-28; ~80% N2, 10% H2 & LPG)									
3/20/2008	1330	Start Test							
4/2/2008	1121	0.2	0.3	11.5	1.8		93.0	16.9	1008
Optimization Test #7 (20 cfh to P4-18, --28, -38 (60 cfh total); ~80% N2, 10% H2 & LPG)									
4/2/2008	1233	Start Test							
4/4/2008									1013
Optimization Test #7B (30 cfh to P4-18, & P4-28 (60 cfh total); ~80% N2, 10% H2 & LPG)									
4/7/2008	1458	Start Test							
4/9/2008	1142	1.3	0.00	8.5	0.1		93.0	16.2	1009

Aerojet GEDIT - Injection Test Input

Phase II Piezometer Monitoring Data

Well ID P4

Depth 38

Date	Time	Well or Injection Gas Sample						Well	Ambient Air	
		O ₂ (%)	CO ₂ (%)	Propane (%)	H ₂ (%)	He (ppm)	RH (%)	Pressure (in wc)	Temperature (C°)	Barometric pressure (mbar)
Optimization Test #7C (50 cfh to P4-18, & P4-28 (100 cfh total); ~79% N2, 10% H2 & LPG, 1% CO2)										
4/10/2009	1121	Start Test								
4/11/2008	1304	1.2	0.00	9.0	0.1		97.0	23.1	1012	
4/16/2008	1201	0.3	2.06	15.0	2.6		55.3	20.2	1011	
4/22/2008	1026	0.8	1.14	6.5	0.50		50.3	17.9	1009	
4/25/2008	1023	0.3	1.44	8.5	0.10		45.8	23.9	1015	
4/29/2008	1129	0.1	1.12	9.0	0.70		43.7	26.6	1007	
5/5/2008	1334	0.0	0.8	8.0	0.55		30.7	37.6	1001	
5/13/2008	1005	0.0	0.76	9.0	0.10		22.5	35.5	1007	
5/20/2008	957	0.0	0.84	9.0	0.10		44.9	23.7	1004	
5/23/2008	1545	1.6	0.78	8.5	0.10		33.3	28.6	990	
5/27/2008	929	0.6	0.86	8.5	0.046		54.0	18.7	1007	
6/4/2008	929	0.0	0.70	8.0	0.70		42.5	24.9	1002	
6/12/2008	1227	0.2	0.66	8.4	0.046		18.1	43.2	1003	
6/20/2008	1057	0.0	0.58	8.5	0.70		19.7	42.0	1005	
6/25/2008	1108	0.0	0.52	8.5	0.10		36.7	30.7	1005	
7/2/2008	1213	0.0	0.50	8.0	0.50		25.6	37.9	1004	
7/7/2008	1200	0	0.42	8	0.46		21.4	36.8	998	
7/18/2008	1126	0	0.48	8	0.1		48.4	27.6		
7/24/2008	1042	0.0	0.50	8.0	0.460		46.3	27.6	1005	

Aerojet GEDIT - Injection Test Input

Phase II Piezometer Monitoring Data

Well ID P4

Depth 38

Date	Time	Well or Injection Gas Sample							Well	Ambient Air
		O ₂ (%)	CO ₂ (%)	Propane (%)	H ₂ (%)	He (ppm)	RH (%)	Pressure (in wc)	Temperature (C°)	Barometric pressure (mbar)
7/31/2008	1036	0.0	0.52	8.0	0.640			51.0	26.3	1003
8/7/2008	914	0.0	0.88	8.0	0.50			82.9	20.8	1004
8/12/2008	1018	0.0	0.50	8.5	0.69			49.0	28.4	1002
Optimization Test #8 (100 cfh of 100% Propane to P4-18, & P4-28 (50 cfh to each point)										
9/8/2008	0905 Test Start									
9/8/2008	1115	1.7	1.86	16.5	0.005					999
9/15/2008	Forgot to measure									
9/29/2008	1007	0.5	0.12	30	0.005			68.1	22.1	1006
10/13/2008	1144	0.5	0.08	30	0.005			37.4	31.1	1017
10/20/2008	1148	0.1	0.10	30	0.005			54.8	27.1	1013
11/5/2008	1338	0.0	0.10	30	0.005			74.4	19.9	1016
11/17/2008	1133	0.0	0.06	30	0.005			61.0	26.0	1014
12/1/2008	1105	0.0	0.04	30	0.005			60.8	20.8	1014

Aerojet GEDIT - Injection Test Input

Phase II Piezometer Monitoring Data

Well ID P4

Depth 48

Date	Time	Well or Injection Gas Sample							Well	Ambient Air	
		O ₂ (%)	CO ₂ (%)	Propane (%)	H ₂ (%)	He (ppm)	RH (%)	Pressure (in wc)	Temperature (C°)	Barometric pressure (mbar)	
12/12/2007	1245	18.9	0.44	0	0.002	80,000	87.8	0.02	12.4	1020	
12/12/2007	1531							0.58			
12/12/2007	1550							0.54			
12/12/2007	1623	0.3				2X10^4					
12/12/2007	1631	0.2				2X10^4					
12/12/2007	1638	0.1				2X10^4					
12/13/2007	758	8.2	0.00	0	0.002	4X10^4	90.5		0	1016	
12/13/2007	838	4.2	0.00	0	0.5	3x10^3	76.0		3.9	1016	
12/13/2007	928	9.1	0	0	7.9		69.1		9.5	1016	
12/13/2007	1200	Discovered leak in O2 - all O2 data for 12/13/07 before 1200 invalid									
12/13/2007	1204	0	0	0			83.4		15.4		
12/13/2007	1316							0.32			
12/13/2007	1324	0	0	0	8.3		75.8		17.1	1014	
12/13/2007	1435	0	0	0.34	3.7		77.0		16.3	1013	
12/13/2007	1516	0	0.02	0.52	0.22		80.3		14.8	1013	
12/13/2007	1551	0	0.04	0.50			79.4		12.5	1013	
12/14/2007	817	0	0.06	0.02	0.5		69.5	0.03	4.2	1013	
12/21/2007	1113	10.2	1.12	0.04	0.46		58.8	0.10	14.3	1013	
12/21/2007	1346	10.4	1.02	0.02	0.52		75.6		13.6	1012	
12/26/2007	1212	14.1	1.06	0	0.22		70.5	0	14.5	1017	
12/26/2007	1418	13.8	0.9	0.02	0.22		78.5		13.7	1015	

Aerojet GEDIT - Injection Test Input

Phase II Piezometer Monitoring Data

Well ID P4

Depth 48

Date	Time	Well or Injection Gas Sample						Well	Ambient Air		
		O ₂ (%)	CO ₂ (%)	Propane (%)	H ₂ (%)	He (ppm)	RH (%)	Pressure (in wc)	Temperature (C°)	Barometric pressure (mbar)	
12/26/2007	1435	13.4	0.82	0.02	0.22			79.5		13.1	1015
12/26/2007	1446	12.9	0.76	0.02	0.22			80.7		13.1	1015
12/26/2007	1545	12.3	0.76	0.04	0.22			85.1		10.8	1015
12/26/2007	1622	11.3	0.68	0.06	0.46			87.1	0.04	9.5	1015
12/27/2007	939	11.5	0.88	0.04	0.98			82.1	0.01	4.5	1017
12/27/2007	1240	11	0.8	0.02	1.4			79.6		9.1	1017
12/27/2007	1415	10.8	0.76	0.02	1.8			85.9		9	1017
12/27/2007	1535	10.8	0.76	0.02	2			89.4	0.01	7.7	1016
1/2/2008	953	5.3	0.44	0	0.22			66.8	0.03	11.1	1012

Tracer Test #1 (10 cfm to INJ2, ~7% H2)											
1/21/2008	1046 Test start										
1/21/2008	1109	3.2	0.54	0	0.98			87.0	0.06	8.7	1008
1/21/2008	1127	2.8	0.52	0	0.97			82.3		7.9	1008
1/21/2008	1159	2.8	0.56	0	0.92			84.3		9.9	1007
1/21/2008	1246	2.7	0.54	0	0.89			82.1	0.08	10.3	1006
1/21/2008	1437	3.0	0.52	0	1.0			82.4	0.05	10.6	1006
1/21/2008	1603	2.8	0.50	0	1.3			86.9		10.0	1006
1/22/2008	918	2.8	0.52	0	2.1			82.5	0.02	7.3	1011
1/22/2008	1350	2.5	0.50	0	1.9			91.1		8.4	1009
1/23/2008	954	2.6	0.54	0	2.0			79.8	0.04	9.2	1007
1/23/2008	1216*	3.3									

Aerojet GEDIT - Injection Test Input

Phase II Piezometer Monitoring Data

Well ID P4

Depth 48

Date	Time	Well or Injection Gas Sample						Well	Ambient Air
		O ₂ (%)	CO ₂ (%)	Propane (%)	H ₂ (%)	He (ppm)	RH (%)	Pressure (in wc)	Temperature (C°)

Tracer Test #2 (20 cfm to INJ2, ~8% H2)										
1/18/2008	1120									
1/18/2008	1130	4.5	0.50	0	0.22		91.6		12.4	1015
1/18/2008	1158	2.3	0.36	0	0.10		93.6		13.1	1015
1/18/2008	1324	2.1	0.34	0	0.10		88.7	0.02	15.8	1014
1/18/2008	1521	1.7	0.28	0	3.5		63.8	0.04	16.9	1014
1/19/2008	952	1.0	0.36	0	8.6		73.3	0.02	10.8	1019
1/19/2008	1100*	1.1	0.30	0	8.0		68.5		15.6	1019

Tracer Test #3 (30 cfm to INJ2, ~4% H2)										
1/30/2008	1036									
1/30/2008	1054	0.1	0.10	0	2.1		88.5	0.19	9.7	1020
1/30/2008	1213	0.0	0.08	0	2.0		89.4		11.3	1019
1/30/2008	1413	0.0	0.06	0	3.5		89.6	0.19	12.5	1018
1/31/2008	931	0.0	0.02	0	4.2		94.3	0.09	8.0	1019
1/31/2008	1125	0	0.02	0	3.8		88.6		9.6	1018

Aerojet GEDIT - Injection Test Input

Phase II Piezometer Monitoring Data

Well ID P4

Depth 48

Date	Time	Well or Injection Gas Sample							Well	Ambient Air
		O ₂ (%)	CO ₂ (%)	Propane (%)	H ₂ (%)	He (ppm)	RH (%)	Pressure (in wc)	Temperature (C°)	Barometric pressure (mbar)
1/31/2008	1325	0	0	0	3.6		85.4	0.25	8.8	1016
1/31/2008	1435									
1/31/2008	1503	0	0.02	0	3.6		88.1	0.14	8.2	1014
1/31/2008	1559	0	0.08	0	3.7		87.4		8.3	1013

Tracer Test #4 (60 cfm to INJ2, ~7% H2)										
1/28/2008	1236 Test start									
1/28/2008	1248	6.6	0.48	0	0.046		95.9		10.1	1010
1/28/2008	1347	1.5	0.38	0	4.2		94.6	0.26	12.2	1010
1/28/2008	1454	0.2	0.18	0	5.5		80.3		12.8	1011
1/28/2008	1541	0.1	0.14	0	5.6		88.0	0.14	10.1	1011
1/29/2008	747	0.0	0.04	0	7.3		87.0	0.25	5.2	1016
1/29/2008	Final O2*	0.0								

Tracer Test #5 (90 cfm to INJ2, ~3% H2)										
2/5/2008	1015 Test start									
2/5/2008	1024	3.6	0.04	0	0.10		83.9	0.27	8.9	1019
2/5/2008	1122	0.2	0	0	2.9		89.0		10.7	1019
2/5/2008	1330	0	0	0	3.9		83.4	0.25	12.2	1019
2/5/2008	1459	0	0	0	3.6		69.6		14.3	1019
2/5/2008	1545	0	0	0	3.5		57.7		17.7	1019

Aerojet GEDIT - Injection Test Input

Phase II Piezometer Monitoring Data

Well ID P4

Depth 48

Date	Time	Well or Injection Gas Sample						Well	Ambient Air
		O ₂ (%)	CO ₂ (%)	Propane (%)	H ₂ (%)	He (ppm)	RH (%)	Pressure (in wc)	Temperature (C°)

Tracer Test #6 (30 cfm total; 10 cfm to each INJ1, 2, and 3; ~8% H2)										
2/7/2008	1500	Test start								
2/7/2008	1523	0.4	0.18	0	0.92		51.2	21.8	1016	
2/7/2008	1613	0.4	0.16	0	0.80		48.7	21.8	1016	
2/8/2008	959	0.0	0.34	0	1.5		60.9	13.5	1017	
2/8/2008	1052	0.0	0.32	0	1.5		82.7	10.8	1017	

Tracer Test #7 (60 cfm total; 20 cfm to each INJ1, 2, and 3, ~5% H2)										
1/17/2008	900	Test start								
1/17/2008	931	13.5	0.92	0	0.022		89.7	0.02	4.9	1015
1/17/2008	1004	12.8	0.68	0	0.022		87.7		7.7	1015
1/17/2008	1109	12.0	0.56	0	0.22		93.5	0.03	9.2	1015
1/17/2008	1210	10.6	0.50	0	0.51		96.9		10.1	1015
1/17/2008	1335	9.8	0.82	0	0.94		98.8		12.5	1013
1/17/2008	1507	9.0	0.78	0	1.5		93.9	0.02	14.1	1012

Tracer Test #8 (90 cfm total; 30 cfm each to INJ1, 2, and 3; ~4.5% H2)										
2/6/2008	1000	Test start								
2/6/2008	1025	0.1	0.04	0	1.1		79.6	0.30	11.8	1020
2/6/2008	1131	0.1	0.04	0	0.87		80.1		12.2	1020
2/6/2008	1237	0.1	0.02	0	0.76		76.1		13.7	1019

Aerojet GEDIT - Injection Test Input

Phase II Piezometer Monitoring Data

Well ID P4

Depth 48

Date	Time	Well or Injection Gas Sample							Well	Ambient Air
		O ₂ (%)	CO ₂ (%)	Propane (%)	H ₂ (%)	He (ppm)	RH (%)	Pressure (in wc)	Temperature (C°)	Barometric pressure (mbar)
2/6/2008	1423	0.1	0.04	0	1.1		68.2	0.06	16.0	1017
2/6/2008	1529	0.1	0.02	0	1.3		64.1		17.0	1017
2/6/2008	1623	0.1	0.12	0	1.6		67.4		16.4	1017

Optimization Test #1 (90 cfm to INJ2 for 4 hours then shut down; ~88% N2, 10% H2, 1% CO2 & LPG)										
2/20/2008	1121	7.6	0.46	0	0.022		77		15.3	1010
2/20/2008	1206 Test start									
2/20/2008	1520	0.2	0.14	1	11		32.7		29.5	1008
2/20/2008	1606 Test End									
2/20/2008	1613	0.1	0.14	1	9.9		47.7		23.1	1008
2/21/2008	907	4.8	0.48	0.1	1.1		81.1		10.7	1005
2/22/2008	1027	5	0.56	0.04	0.62		84.8		9.9	1003

Optimization Test #2 (30 cfm to INJ2 for 12 hours then shut down; ~88% N2, 10% H2, 1% CO2 & LPG)										
2/25/2008	1845 Test Start									
2/26/2008	653 Test End									
2/26/2008	700	1.0	0.5	0.58	5.8		91.4		2.8	1017
2/27/2008	1526	19.0	0.1	0	0.046		43.5		31.8	1009
2/28/2008	1042	20.1	0.08	0	0.022		82.9		15.7	1008

Aerojet GEDIT - Injection Test Input

Phase II Piezometer Monitoring Data

Well ID P4

Depth 48

Date	Time	Well or Injection Gas Sample						Well	Ambient Air
		O ₂ (%)	CO ₂ (%)	Propane (%)	H ₂ (%)	He (ppm)	RH (%)	Pressure (in wc)	Temperature (C°)
Optimization Test #3A (1 cfm to INJ2; ~88% N2, 10% H2, 1% CO2 & LPG)									
2/29/2008	1319 Test Start								
2/29/2008	1415	18.8	0.00	0.02	0.022		59.2	23.1	1009
2/29/2008	1515	18.8	0	0.02	0.022		60.8	23.1	1009
3/3/2008	1036	20.1	0.02	0	0.01		83.8	14.9	1019
3/3/2008	1130 Test End								
Optimization Test #3B (1 cfm to INJ1, INJ2 & INJ3; ~88% N2, 10% H2, 1% CO2 & LPG)									
3/3/2008	1130 Test Start								
3/4/2008	923	19.9	0.1	0	0.01		85.2	11.7	1013
3/7/2008	1046	19.3	0	0	0.022		66.6	18.5	1018
3/7/2008	1306 Test End								
Optimization Test #3C (90 cfm to INJ1, INJ2 & INJ3 for 15 minutes then shut down; ~79% N2, 10% H2 & LPG, 1% CO2)									
3/7/2008	1306 Start Pulse								
3/7/2008	1321 End Pulse								
3/7/2008	1332	16.5	0	0	0.005		53.2	23.2	1016
3/10/2008	1042	19.3	0.04	0	0.022		81.2	16.2	1016

Aerojet GEDIT - Injection Test Input

Phase II Piezometer Monitoring Data

Well ID P4

Depth 48

Date	Time	Well or Injection Gas Sample						Well	Ambient Air
		O ₂ (%)	CO ₂ (%)	Propane (%)	H ₂ (%)	He (ppm)	RH (%)	Pressure (in wc)	Temperature (C°)
Optimization Test #4 (2, 45-minutes pulses; daily 15-minutes pulses w/30cfh constant flow)									
3/10/2008	1347	End pulse							
3/10/2008	1405	12.7	0.10	0.16	0.01		58.4	22.6	1015
3/11/2008	908	20.6	0.06	0	0.01		66.2	14.9	1017
3/12/2008	956	18.7	0.08	0	0.01		88.4	12.5	1014
3/13/2008	911	18.7	0.06	0	0.01		91.2	13.7	1011
3/14/2008	1137	18.6	0.08	0	0.022		91.4	13.7	1013
3/14/2008	1211	16.7	0.06	0.02	0.01		81.4	14.9	1012
3/15/2008	1121	18.6	0.10	0	0.022		89	11.2	1009
3/16/2008	1108	16.1	0.04	0.04	0.022		83.1	14.6	1009
3/17/2008	920	16.4	0.16	0.06	0.01		86.7	8.8	1014
Optimization Test #5 (20 cfm to INJ2 for 125 minutes while maintaing 30 cfh the rest of the time; ~80% N2, 10% H2 & LPG)									
3/17/2008	1037	Start Test							
3/17/2008	1251	8.5	0.06	3.5	0.5		84.4	17.7	1014
3/8/2008	939	16.7	0.14	0.14	0.022		86.4	12.8	1016
3/19/2008	956	15.2	0.14	0.16	0.022		90.8	11.9	1013
3/20/2008	940	14.6	0.18	0.46	0.01		87.3	9	1016
3/20/2008	~1100	End Test							

Aerojet GEDIT - Injection Test Input

Phase II Piezometer Monitoring Data

Well ID P4

Depth 48

Date	Time	Well or Injection Gas Sample						Well	Ambient Air
		O ₂ (%)	CO ₂ (%)	Propane (%)	H ₂ (%)	He (ppm)	RH (%)	Pressure (in wc)	Temperature (C°)
Optimization Test #6 (50 cfh to P4-18 & P4-28; ~80% N ₂ , 10% H ₂ & LPG)									
3/20/2008	1330	Start Test							
4/2/2008	1122	1.8	0.24	9.5	0.046		81.3	16.7	1008
Optimization Test #7 (20 cfh to P4-18, --28, -38 (60 cfh total); ~80% N ₂ , 10% H ₂ & LPG)									
4/2/2008	1233	Start Test							
4/4/2008	1002	1.6	0.26	10.0	0.046		80.5	14.1	1013
4/7/2008	1433	5.1	0.52	7.0	0.046		55.5	19.5	1011
Optimization Test #7B (30 cfh to P4-18, & P4-28 (60 cfh total); ~80% N ₂ , 10% H ₂ & LPG)									
4/7/2008	1458	Start Test							
4/9/2008	1139	1.8	0.38	8.0	0.046		89.8	16.0	1009
Optimization Test #7C (50 cfh to P4-18, & P4-28 (100 cfh total); ~79% N ₂ , 10% H ₂ & LPG, 1% CO ₂)									
4/10/2009	1121	Start Test							
4/11/2008	1303	1.6	0.48	8.5	0.022		96.9	23.1	1012
4/16/2008	1202	0.2	0.46	14.5	0.220		57.1	20.2	1011
4/22/2008	1028	8.2	0.54	5.5	0.010		56.1	17.9	1009
4/25/2008	1021	0.8	0.64	11.5	0.010		43.4	23.5	1015
4/29/2008	1130	0.5	0.66	11.0	0.10		44.3	26.8	1007
5/5/2008	1332	0.3	0.8	10.0	0.046		34.3	38.4	1001
5/13/2008	1007	0.1	0.86	9.5	0.10		25.4	35.5	1007

Aerojet GEDIT - Injection Test Input

Phase II Piezometer Monitoring Data

Well ID P4

Depth 48

Date	Time	Well or Injection Gas Sample							Well	Ambient Air
		O ₂ (%)	CO ₂ (%)	Propane (%)	H ₂ (%)	He (ppm)	RH (%)	Pressure (in wc)	Temperature (C°)	Barometric pressure (mbar)
5/20/2008	958	0.0	0.86	9.5	0.10			50.7	24.4	1004
5/23/2008	1547	0.0	0.78	9.5	0.10			38.9	28.4	990
5/27/2008	930	0.0	1.00	9.5	0.046			68.3	18.6	1007
6/4/2008	931	0.0	1.08	9.0	0.046			47.7	24.8	1002
6/12/2008	1229	0.0	0.96	8.5	0.10			18.2	43.3	1003
6/20/2008	1058	0.0	0.96	8.5	0.046			19.2	42.6	1005
6/25/2008	1109	0.0	0.72	8.5	0.10			37.9	31.3	1005
7/2/2008	1215	0.0	1.04	8.0	0.10			24.7	38.4	1004
7/7/2008	1159	0.0	1	8.0	0.1			28.4	36.7	998
7/18/2008	1127	0.0	1.12	7.5	0.1			56.4	29	
7/24/2008	1043	0.0	1.12	8.0	0.100			45.5	27.5	1005
7/31/2008	1037	0.0	1.18	7.5	0.100			50.4	26.4	1003
8/7/2008	915	0.0	0.52	8.5	0.78			81.5	20.9	1004
8/12/2008	1019	0.0	1.10	7.5	0.100			57.3	28.4	1002
Optimization Test #8 (100 cfh of 100% Propane to P4-18, & P4-28 (50 cfh to each point)										
9/8/2008	0905 Test Start									
9/8/2008	1117	0.0	0.88	21.0	0.010					999
9/15/2008	Forgot to measure									1007
9/29/2008	1008	0.0	1.46	30	0.005			32.4	22.0	1006
10/13/2008	1146	0.1	1.20	30	0.005			39.1	30.9	1017
10/20/2008	1150	0.1	1.10	30	0.005			56.7	26.9	1013
11/5/2008	1339	0.0	0.96	30	0.005			72.9	19.9	1016

Aerojet GEDIT - Injection Test Input

Phase II Piezometer Monitoring Data

Well ID P4

Depth 48

Date	Time	Well or Injection Gas Sample							Well	Ambient Air
		O ₂ (%)	CO ₂ (%)	Propane (%)	H ₂ (%)	He (ppm)	RH (%)	Pressure (in wc)	Temperature (C°)	Barometric pressure (mbar)
11/17/2008	1134	0.0	0.76	30	0.010		63.7		26.1	1014
12/1/2008	1105	0.0	0.72	30	0.005		61.7		20.7	1014

Aerojet GEDIT - Injection Test Input

Phase II Piezometer Monitoring Data

Well ID P5

Depth 18

Date	Time	Well or Injection Gas Sample							Well	Ambient Air	
		O ₂ (%)	CO ₂ (%)	Propane (%)	H ₂ (%)	He (ppm)	RH (%)	Pressure (in wc)	Temperature (C°)	Barometric pressure (mbar)	
12/12/2007	1205	19.7	0.20	0	0.002	70,000	78.2	0.02	12.2	1020	
12/12/2007	1534							0.20			
12/12/2007	1626	19.3				3x10 ⁴					
12/12/2007	1633	19.1				3x10 ⁴					
12/12/2007	1642	18.6				3x10 ⁴					
12/13/2007	801	15.5	0.12	0	0.002	2X10 ⁴	86.3		0.6	1016	
12/13/2007	838	11.6	0.18	0	0.22	2X10 ⁴	72.0		3.9	1016	
12/13/2007	934	14.4	0	0	0.22		56.9		10.9	1016	
12/13/2007	1200	Discovered leak in O2 - all O2 data for 12/13/07 before 1200 invalid									
12/13/2007	1205	0.6	0.28	0							
12/13/2007	1315							0.15			
12/13/2007	1325	0.3	0.24	0	7.4		69.5		17.2	1013	
12/13/2007	1448	0	0.20	0	8.6		80.6		13.8	1013	
12/13/2007	1519	0	0.18	0	8.5		75.1		14.7	1013	
12/13/2007	1553	0	0.16	0.16			81.0		12.6	1013	
12/14/2007	828	0.5	0.24	0.30	1.3		68.2	0.05	4.6	1016	
12/21/2007	1159	8.1	0.30	0.08	0.46		88.6	0.03	10.1	1013	
12/26/2007	1223	13.1	0.26	0.06	0.22		79.8	0.03	12.7	1017	
12/26/2007	1515	13.2	0.28	0.06	0.22		79.2		12.1	1015	
12/26/2007	1609	13.4	0.3	0.06	0.22		81.6	0.04	10.3	1015	

Aerojet GEDIT - Injection Test Input

Phase II Piezometer Monitoring Data

Well ID P5

Depth 18

Date	Time	Well or Injection Gas Sample						Well	Ambient Air	
		O ₂ (%)	CO ₂ (%)	Propane (%)	H ₂ (%)	He (ppm)	RH (%)	Pressure (in wc)	Temperature (C°)	Barometric pressure (mbar)
12/27/2007	1011	3.4	0.32	0	7.4		74.8	0.03	6	1018
12/27/2007	1316	1.6	0.24	0	8.6		82.5		8.6	1016
12/27/2007	1437	1.4	0.24	0	8.7		87.0		8.3	1017
12/27/2007	1554	1.3	0.24	0	9.1		87.4	0.05	7.5	1016
1/2/2008	1031	0.5	0.22	0	0.22		62.0	0.04	17	1012

Tracer Test #1 (10 cfm to INJ2, ~7% H2)										
1/21/2008	1046 Test start									
1/21/2008	1131	1.9	0.08	0	0.86		80.1	0.11	10.0	1008
1/21/2008	1251	1.3	0.06	0	0.72		80.3	0.01	10.6	1006
1/21/2008	1443	1.2	0.04	0	0.81		77.0	0.08	10.7	1006
1/21/2008	1608	1.1	0.06	0	1.1		96.0	0.04	10.0	1006
1/22/2008	950	0.8	0.06	0	5.3		85.3	0.06	6.8	1011
1/22/2008	1352	0.7	0.04	0	5.9		90.8		8.4	1009
1/23/2008	1012	0.7	0.08	0	6.4		81.7	0.07	9.0	1007
1/23/2008	1110*	0.6			6.5					

Tracer Test #2 (20 cfm to INJ2, ~8% H2)										
1/18/2008	1120 Test start									
1/18/2008	1132	1.7	0.10	0	0.61		83.1		12.4	1015

Aerojet GEDIT - Injection Test Input

Phase II Piezometer Monitoring Data

Well ID P5

Depth 18

Date	Time	Well or Injection Gas Sample						Well	Ambient Air	
		O ₂ (%)	CO ₂ (%)	Propane (%)	H ₂ (%)	He (ppm)	RH (%)	Pressure (in wc)	Temperature (C°)	Barometric pressure (mbar)
1/18/2008	1214	1.6	0.10	0	0.57		77.1	0.03	13.4	1015
1/18/2008	1316	1.3	0.10	0	0.53		64.8		15.4	1014
1/18/2008	1348	1.5	0.08	0	0.69		65.3		15.4	1014
1/18/2008	1524	1.5	0.08	0	1.4		57.9	0.04	18.1	1014
1/19/2008	954	0.9	0.16	0	9.9		64.3	0.02	10.4	1019
1/19/2008	1136*	0.6	0.10	0	10.0		61.5		12.8	1018

Tracer Test #3 (30 cfm to INJ2, ~4% H2)										
1/30/2008	1036 Test start									
1/30/2008	1102	0.0	0	0	1.0		84.5	0.09	9.4	1020
1/30/2008	1216	0.0	0	0	0.95		78.3		11.3	1019
1/30/2008	1416	0.0	0	0	2.0		74.7	0.11	12.5	1018
1/31/2008	932	0.0	0	0	4.2		92.2	0.20	8.0	1019
1/31/2008	1126	0	0	0	3.8		85.5		9.6	1018
1/31/2008	1335	0	0	0	3.7		85.9	0.12	8.7	1016
1/31/2008	1435									
1/31/2008	1505	0	0	0	3.7		87.9	0.03	8.2	1014
1/31/2008	1601	0	0	0	3.7		87.3		8.3	1013

Aerojet GEDIT - Injection Test Input

Phase II Piezometer Monitoring Data

Well ID P5

Depth 18

Date	Time	Well or Injection Gas Sample						Well	Ambient Air
		O ₂ (%)	CO ₂ (%)	Propane (%)	H ₂ (%)	He (ppm)	RH (%)	Pressure (in wc)	Temperature (C°)

Tracer Test #4 (60 cfm to INJ2, ~7% H2)										
1/28/2008	1236 Test start									
1/28/2008	1251	0.6	0.08	0	0.046		90.1		10.4	1010
1/28/2008	1407	1.0	0.08	0	0.10		73.0	0.16	13.2	1010
1/28/2008	1544	0.5	0.02	0	3.4		83.9	0.16	10.1	1011
1/29/2008	750	0.0	0	0	7.3		83.5	0.09	5.0	1016
1/29/2008	Final O2*		0.0							

Tracer Test #5 (90 cfm to INJ2, ~3% H2)										
2/5/2008	1015 Test start									
2/5/2008	1025	0.2	0	0	0.10		77.3	0.20	9.0	1019
2/5/2008	1123	0.2	0	0	0.10		74.9		10.7	1019
2/5/2008	1332	0	0	0	3.3		77.1	0.20	12.1	1019
2/5/2008	1502	0	0	0	3.5		66.3		14.3	1019
2/5/2008	1546	0	0	0	3.3		55.4		17.8	1019

Tracer Test #6 (30 cfm total; 10 cfm to each INJ1, 2, and 3; ~8% H2)										
2/7/2008	1500 Test start									
2/7/2008	1526	0.0	0.02	0	0.58		47.8		21.3	1016

Aerojet GEDIT - Injection Test Input

Phase II Piezometer Monitoring Data

Well ID P5

Depth 18

Date	Time	Well or Injection Gas Sample						Well	Ambient Air	
		O ₂ (%)	CO ₂ (%)	Propane (%)	H ₂ (%)	He (ppm)	RH (%)	Pressure (in wc)	Temperature (C°)	Barometric pressure (mbar)
2/7/2008	1615	0.0	0	0	0.46		45.4		21.5	1016
2/8/2008	1003	0.0	0	0	8.6		60.2		12.5	1017

Tracer Test #7 (60 cfm total; 20 cfm to each INJ1, 2, and 3, ~5% H2)										
1/17/2008	900 Test start									
1/17/2008	951	12.7	0.06	0	0.022		89.2	0.03	7.1	1015
1/17/2008	1021	12.9	0.04	0	0.22		94.7	0.02	8.3	1015
1/17/2008	1152	11.3	0.02	0	1.4		86.9	0.02	10.0	1015
1/17/2008	1345	6.5	0.20	0	3.6		88.6		12.4	1013
1/17/2008	1509	4.7	0.20	0	4.3		86.3	0.02	14.3	1012

Tracer Test #8 (90 cfm total; 30 cfm each to INJ1, 2, and 3; ~4.5% H2)										
2/6/2008	1000 Test start									
2/6/2008	1027	0.0	0	0	0.92		72.9	0.21	11.6	1020
2/6/2008	1138	0.0	0	0	1.0		69.9		12.4	1020
2/6/2008	1239	0.0	0	0	1.9		67.6		13.8	1019
2/6/2008	1428	0.0	0	0	3.7		61.6	0.23	16.2	1017
2/6/2008	1531	0.0	0	0	3.8		59.4		17.0	1017
2/6/2008	1625	0.0	0	0	4.0		61.9		16.5	1017

Aerojet GEDIT - Injection Test Input

Phase II Piezometer Monitoring Data

Well ID P5

Depth 18

Date	Time	Well or Injection Gas Sample						Well	Ambient Air
		O ₂ (%)	CO ₂ (%)	Propane (%)	H ₂ (%)	He (ppm)	RH (%)	Pressure (in wc)	Temperature (C°)
Optimization Test #1 (90 cfm to INJ2 for 4 hours then shut down; ~88% N2, 10% H2, 1% CO2 & LPG)									
2/20/2008	1130	4.5	0.00	0	0.046		70.8	15.1	1010
2/20/2008	1206 Test start								
2/20/2008	1537	0.5	0.00	0.94	10		52.1	21.9	1007
2/20/2008	1606 Test End								
2/20/2008	1622	0.4	0.00	0.96	9.8		46.7	22.3	1008
2/21/2008	909	0.2	0.00	0.92	9.4		78.6	10.6	1005
2/22/2008	1035	0.9	0.06	0.88	6		84.4	9.7	1003
2/25/2008	1642	4.8	0.10	0.54	0.5		48.8	22.9	1017
Optimization Test #2 (30 cfm to INJ2 for 12 hours then shut down; ~88% N2, 10% H2, 1% CO2 & LPG)									
2/25/2008	1845 Test Start								
2/26/2008	653 Test End								
2/26/2008	702	0.5	0.48	0.74	6.3		93.4	3.5	1017
2/27/2008	1530	0.2	0.4	0.5	4.8		39.7	32.3	1009
2/28/2008	1050	0.7	0.38	0.46	3		70.6	15.8	1007
Optimization Test #3A (1 cfm to INJ2; ~88% N2, 10% H2, 1% CO2 & LPG)									
2/29/2008	1319 Test Start								
2/29/2008	1427	2.3	0.40	0.44	1.3		41.9	23.2	1009

Aerojet GEDIT - Injection Test Input

Phase II Piezometer Monitoring Data

Well ID P5

Depth 18

Date	Time	Well or Injection Gas Sample						Well	Ambient Air	
		O ₂ (%)	CO ₂ (%)	Propane (%)	H ₂ (%)	He (ppm)	RH (%)	Pressure (in wc)	Temperature (C°)	Barometric pressure (mbar)
2/29/2008	1516	2.2	0.42	0.44	0.92		58.3		22.9	1009
3/3/2008	1044	0	0.56	0.78	6.6		65.7		15.1	1019
3/3/2008	1130 Test End									

Optimization Test #3B (1 cfm to INJ1, INJ2 & INJ3; ~88% N2, 10% H2, 1% CO2 & LPG)										
3/3/2008	1130 Test Start									
3/4/2008	925	0.5	0.72	0.76	5.6		77.2		12	1013
3/7/2008	1054	0.6	0.5	0.8	5.7		58.4		18.2	1018
3/7/2008	1306 Test End									

Optimization Test #3C (90 cfm to INJ1, INJ2 & INJ3 for 15 minutes then shut down; ~79% N2, 10% H2 & LPG, 1% CO2)										
3/7/2008	1306 Start Pulse									
3/7/2008	1321 End Pulse									
3/7/2008	1333	0.6	0.48	0.78	4.9		48.3		22.9	1016
3/10/2008	1049	4.3	0.52	0.94	0.5		66.8		16.4	1016

Optimization Test #4 (2, 45-minutes pulses; daily 15-minutes pulses w/30cfh constant flow)										
3/10/2008	1233	4.5	0.64	0.92	0.5		54.8		20.5	1016
3/10/2008	1254	4.6	0.64	0.9	0.22					
3/10/2008	1317	4.9	0.68	0.88	0.22		53.6		21.3	1016
3/10/2008	1347	End pulse								

Aerojet GEDIT - Injection Test Input

Phase II Piezometer Monitoring Data

Well ID P5

Depth 18

Date	Time	Well or Injection Gas Sample						Well	Ambient Air	
		O ₂ (%)	CO ₂ (%)	Propane (%)	H ₂ (%)	He (ppm)	RH (%)	Pressure (in wc)	Temperature (C°)	Barometric pressure (mbar)
3/10/2008	1407	5.0	0.64	0.68	0.1		49.6		22.6	1015
3/11/2008	911	3.4	0.64	1.7	3.9		68		14.7	1017
3/12/2008	958	0.5	0.64	4.5	7.7		82.5		12.7	1014
3/13/2008	913	0.1	0.60	5.5	8.2		85.8		13.8	1011
3/14/2008	1138	0.1	0.58	6	4.9		83.8		13.7	1013
3/14/2008	1213	0.0	0.56	6	4.9		78.3		14.8	1012
3/15/2008	1122	0.4	0.58	4.5	4.3		82.8		11.2	1009
3/16/2008	1110	1.4	0.40	3.5	3.4		75.9		14.4	1009
3/17/2008	922	2.3	0.52	3	5		81.4		9	1014

Optimization Test #5 (20 cfm to INJ2 for 125 minutes while maintaing 30 cfh the rest of the time; ~80% N2, 10% H2 & LPG)										
3/17/2008	1037	Start Test								
3/17/2008	1254	2.5	0.42	4	7.7		67.5		17.8	1014
3/18/2008	940	1.2	0.52	8	7.9		80.1		12.8	1016
3/19/2008	957	0.6	0.48	9	6.4		83.7		11.9	1013
3/20/2008	942	0.4	0.48	9	8		82.6		9.3	1016
3/20/2008	~1100	End Test								

Optimization Test #6 (50 cfh to P4-18 & P4-28; ~80% N2, 10% H2 & LPG)										
3/20/2008	1330	Start Test								
3/21/2008	1002	0.0	0.36	4.0	5.8		81.8		11.8	1020

Aerojet GEDIT - Injection Test Input

Phase II Piezometer Monitoring Data

Well ID P5

Depth 18

Date	Time	Well or Injection Gas Sample						Well	Ambient Air
		O ₂ (%)	CO ₂ (%)	Propane (%)	H ₂ (%)	He (ppm)	RH (%)	Pressure (in wc)	Temperature (C°)
3/24/2008	1002	0.0	0.24	2.0	4.2		59.6	16.4	1012
3/26/2008	943	0.0	0.18	2.0	4.9		85.0	10.7	1017
3/28/2008	941	0.0	0.14	2.0	2.6		79.7	10.4	1009
3/31/2008	942	0.0	0.10	14.5	11.0		81.3	9.2	1013
4/2/2008	1040	0.0	0.10	13.5	11.0		84.8	13.5	1008
Optimization Test #7 (20 cfh to P4-18, --28, -38 (60 cfh total); ~80% N2, 10% H2 & LPG)									
4/2/2008	1233 Start Test								
4/4/2008	924	0.0	0.08	11.5	16.0		83.5	12.0	1013
4/7/2008	1350	0.1	0.02	4.5	26.0		62.4	19.2	1012
Optimization Test #7B (30 cfh to P4-18, & P4-28 (60 cfh total); ~80% N2, 10% H2 & LPG)									
4/7/2008	1458 Start Test								
4/9/2008	1034	0.2	0.00	0.8	36.0		80.3	14.2	1009
Optimization Test #7C (50 cfh to P4-18, & P4-28 (100 cfh total); ~79% N2, 10% H2 & LPG, 1% CO2)									
4/10/2009	1121 Start Test								
4/11/2008	1219	0.0	0.00	0.2	18.0		60.9	21.2	1013
4/14/2008	1001	0.6	1.52	25.5	7.3		81.5	15.6	1007
4/16/2008	1014	0.0	2.08	9.5	9.6		80.9	14.4	1011
4/22/2008	1031	0.0	0.32	10.0	14		75.9	18.1	1009

Aerojet GEDIT - Injection Test Input

Phase II Piezometer Monitoring Data

Well ID P5

Depth 18

Date	Time	Well or Injection Gas Sample						Well	Ambient Air	
		O ₂ (%)	CO ₂ (%)	Propane (%)	H ₂ (%)	He (ppm)	RH (%)	Pressure (in wc)	Temperature (C°)	Barometric pressure (mbar)
4/23/2008	931	0.0	0.32	9.0	2.5		79.0		12.9	1010
4/25/2008	942	0.0	0.20	9.5	0.10		66.5		19.3	1015
4/29/2008	1053	0.0	0.16	8.5	7.7		60.1		24.9	1007
5/5/2008	1258	0.0	0.78	9.0	11.0		41.6		33.2	1001
5/13/2008	910	0.0	0.86	9.5	2.4		47.3		29.5	1007
5/20/2008	917	0.0	0.64	7.5	19		64.1		24.5	1004
5/23/2008	1502	0.3	0.56	7.5	18		41.0		33.4	990
5/27/2008	848	0.0	1.40	9.5	9.1		78.4		15.8	1007
6/4/2008	850	0.0	0.30	9.5	6.6		69.9		20.9	1002
6/12/2008	1124	0.0	0.60	9.0	4.7		34.0		38.0	1003
6/20/2008	1000	0.0	1.02	8.5	7.1		48.3		32.1	1005
6/25/2008	1028	0.0	0.80	8.5	14.0		56.5		29.3	1005
7/2/2008	1130	0.0	1.00	9.0	14.0		44.0		33.3	1004
7/7/2008	1119	0	0.34	9	7.6		41.4		35	998
7/18/2008	1046	0	0.24	9	11		76.5		24.6	
7/24/2008	1045	0.0	0.38	8.5	13.000		68.2		27.5	1005
7/31/2008	1045	0.0	0.90	9.0	11.000		74.0		26.7	1003
8/7/2008	917	0.0	0.36	8.5	9.5		90.1		21.6	1004
8/12/2008	1022	0.0	0.08	9.0	11.0		63.0		28.8	1002

Aerojet GEDIT - Injection Test Input

Phase II Piezometer Monitoring Data

Well ID P5

Depth 18

Date	Time	Well or Injection Gas Sample						Well	Ambient Air	
		O ₂ (%)	CO ₂ (%)	Propane (%)	H ₂ (%)	He (ppm)	RH (%)	Pressure (in wc)	Temperature (C°)	Barometric pressure (mbar)
Optimization Test #8 (100 cfh of 100% Propane to P4-18, & P4-28 (50 cfh to each point))										
9/8/2008	0905 Test Start									
9/8/2008	1012	9.3	0.80	3.5	0.002					999
9/15/2008	906	4.9	0.64	30	0.002		60.1	25.0		1007
9/29/2008	926	6.0	0.60	30	0.002		60.3	25.1		1006
10/13/2008	1148	6.3	0.46	30	0.005		42.2	30.2		1017
10/20/2008	1115	5.7	0.50	30	0.010		56.2	24.7		1013
11/5/2008	1353	5.6	0.60	30	0.005		76.7	18.7		1016
11/17/2008	1106	4.8	0.60	30	0.010		38.1	31.2		1014
12/1/2008	1107	4.7	0.66	30	0.002		54.9	20.7		1014

Aerojet GEDIT - Injection Test Input

Phase II Piezometer Monitoring Data

Well ID P5

Depth 28

Date	Time	Well or Injection Gas Sample						Well	Ambient Air		
		O ₂ (%)	CO ₂ (%)	Propane (%)	H ₂ (%)	He (ppm)	RH (%)	Pressure (in wc)	Temperature (C°)	Barometric pressure (mbar)	
12/12/2007	1207	19.8	0.18	0	0.002	50,000	80.9	0.04	12.2	1020	
12/12/2007	1534							0.24			
12/12/2007	1628	0.2				<1x10 ²					
12/12/2007	1635	0.1				2x10 ³					
12/12/2007	1643	0.1				4x10 ³					
12/13/2007	805	10.0	0.00	0	0.002	9X10 ³	86.4		1.0	1016	
12/13/2007	840	3.9	0.00	0	5.3	7X10 ³	73.7		4.1	1016	
12/13/2007	935	11.0	0	0	8.1		59.7		11.4	1016	
12/13/2007	1200	Discovered leak in O2 - all O2 data for 12/13/07 before 1200 invalid									
12/13/2007	1316							0.20			
12/13/2007	1326	0	0	0	8.4		64.8		17.3	1014	
12/13/2007	1444	0	0.36	0.50	0.51		76.4		14.3	1013	
12/13/2007	1520	0	0.52	0.52	0.22		74.1		14.7	1013	
12/13/2007	1554	0	0.58	0.52			77.1		12.8	1013	
12/14/2007	829	0	0.10	0	0.46		68.9	0.02	4.3	1016	
12/21/2007	1201	14.0	0.026	0.04	0.46		88.3	0.04	10.0	1013	
12/26/2007	1227	17.0	0.26	0.02	0.22		83.7	0.02	12.2	1016	
12/26/2007	1611	6.6	0.3	0.02	2.9		82.2	0.05	10.2	1015	
12/27/2007	1014	0.2	0.1	0	9.2		78.3	0.05	6.0	1018	
12/27/2007	1318	0.1	0	0	9.2		84.9		8.5	1016	

Aerojet GEDIT - Injection Test Input

Phase II Piezometer Monitoring Data

Well ID P5

Depth 28

Date	Time	Well or Injection Gas Sample						Well	Ambient Air	
		O ₂ (%)	CO ₂ (%)	Propane (%)	H ₂ (%)	He (ppm)	RH (%)	Pressure (in wc)	Temperature (C°)	Barometric pressure (mbar)
12/27/2007	1439	0.1	0	0	9.3		88.3		8.4	1017
12/27/2007	1556	0.1	0	0	9.8		90.2	0.06	7.5	1017
1/2/2008	1034	0.1	0	0	0.22		56.2	0.02	16.9	1012

Tracer Test #1 (10 cfm to INJ2, ~7% H2)										
1/21/2008	1046 Test start									
1/21/2008	1132	1.2	0	0	1.6		83.5	0.09	9.8	1008
1/21/2008	1253	0.9	0	0	5.1		84.8	0.07	10.7	1006
1/21/2008	1444	0.9	0	0	6.0		81.6	0.08	10.8	1006
1/21/2008	1609	0.9	0	0	6.1		96.4	0.07	10.0	1006
1/22/2008	952	0.8	0	0	6.9		84.9	0.06	6.9	1011
1/22/2008	1353	0.6	0	0	7.0		88.0		8.5	1009
1/23/2008	1020	0.7	0	0	6.8		84.6	0.08	8.6	1007
1/23/2008	1111*	0.7			6.8					

Tracer Test #2 (20 cfm to INJ2, ~8% H2)										
1/18/2008	1120 Test start									
1/18/2008	1133	1.1	0.04	0	0.10		85.1		12.5	1015
1/18/2008	1215	0.7	0	0	5.7		84.1	0.04	13.4	1015
1/18/2008	1317	0.6	0	0	6.7		78.0		15.4	1014

Aerojet GEDIT - Injection Test Input

Phase II Piezometer Monitoring Data

Well ID P5

Depth 28

Date	Time	Well or Injection Gas Sample						Well	Ambient Air	
		O ₂ (%)	CO ₂ (%)	Propane (%)	H ₂ (%)	He (ppm)	RH (%)	Pressure (in wc)	Temperature (C°)	Barometric pressure (mbar)
1/18/2008	1349	0.8	0	0	6.8		80.6		15.4	1014
1/18/2008	1526	0.8	0	0	7.2		60.6	0.03	20.3	1014
1/19/2008	1004	0.6	0	0	7.0		70.4	0.02	9.4	1019
1/19/2008	1138*	0.8	0	0	6.1		67.2		12.6	1018

Tracer Test #3 (30 cfm to INJ2, ~4% H2)										
1/30/2008	1036 Test start									
1/30/2008	1103	0.0	0	0	3.5		86.0	0.11	9.4	1020
1/30/2008	1217	0.0	0	0	4.3		79.1		11.1	1019
1/30/2008	1417	0.0	0	0	4.7		80.5	0.13	12.6	1018
1/31/2008	940	0.0	0	0	4.2		90.0	0.10	8.3	1019
1/31/2008	1127	0	0	0	3.7		84.7		9.6	1018
1/31/2008	1337	0	0	0	3.7		85.0	0.14	8.7	1016
1/31/2008	1435									
1/31/2008	1507	0	0	0	3.8		87.4	0.04	8.2	1014
1/31/2008	1602	0	0	0	3.9		86.8		8.3	1013

Tracer Test #4 (60 cfm to INJ2, ~7% H2)										
1/28/2008	1236 Test start									
1/28/2008	1253	0.2	0	0	4.6		92.6		10.5	1010

Aerojet GEDIT - Injection Test Input

Phase II Piezometer Monitoring Data

Well ID P5

Depth 28

Date	Time	Well or Injection Gas Sample						Well	Ambient Air	
		O ₂ (%)	CO ₂ (%)	Propane (%)	H ₂ (%)	He (ppm)	RH (%)	Pressure (in wc)	Temperature (C°)	Barometric pressure (mbar)
1/28/2008	1406	0.0	0	0	6.0		71.6	0.20	13.2	1010
1/28/2008	1547	0.0	0	0	6.3		84.6	0.17	10.1	1011
1/29/2008	752	0.0	0	0	7.3		86.0	0.10	5.0	1016
1/29/2008	Final O2*	0.0								

Tracer Test #5 (90 cfm to INJ2, ~3% H2)										
2/5/2008	1015 Test start									
2/5/2008	1027	0	0	0	3.1		72.0	0.26	9.2	1019
2/5/2008	1125	0	0	0	3.4		75.3		10.7	1019
2/5/2008	1333	0	0	0	4.0		76.0	0.26	12.2	1019
2/5/2008	1503	0	0	0	3.7		69.0		14.4	1019
2/5/2008	1547	0	0	0	3.5		55.4		17.9	1018

Tracer Test #6 (30 cfm total; 10 cfm to each INJ1, 2, and 3; ~8% H2)										
2/7/2008	1500 Test start									
2/7/2008	1527	0.0	0	0	0.046		45.4		21.8	1016
2/7/2008	1615	0.0	0	0	1.3		45.0		21.4	1016
2/8/2008	1004	0.0	0	0	8.7		61.3		11.6	1017

Aerojet GEDIT - Injection Test Input

Phase II Piezometer Monitoring Data

Well ID P5

Depth 28

Date	Time	Well or Injection Gas Sample						Well	Ambient Air
		O ₂ (%)	CO ₂ (%)	Propane (%)	H ₂ (%)	He (ppm)	RH (%)	Pressure (in wc)	Temperature (C°)
Tracer Test #7 (60 cfm total; 20 cfm to each INJ1, 2, and 3, ~5% H2)									
1/17/2008	900 Test start								
1/17/2008	952	15.6	0	0	0.46	82.6	0.04	7.2	1015
1/17/2008	1022	13.4	0	0	1.1	94.8	0.02	8.3	1015
1/17/2008	1154	6.6	0	0	3.8	86.9	0.03	10.0	1015
1/17/2008	1347	3.5	0.16	0	4.8	89.4		12.5	1013
1/17/2008	1511	2.4	0.18	0	5.2	81.8	0.05	14.8	1012
Tracer Test #8 (90 cfm total; 30 cfm each to INJ1, 2, and 3; ~4.5% H2)									
2/6/2008	1000 Test start								
2/6/2008	1029	0.0	0	0	0.79	73.4	0.19	11.4	1020
2/6/2008	1139	0.0	0	0	3.1	69.9		12.5	1020
2/6/2008	1240	0.0	0	0	3.8	67.6		13.9	1019
2/6/2008	1426	0.0	0	0	4.6	61.4	0.21	16.0	1017
2/6/2008	1532	0.0	0	0	4.5	58.5		17.1	1017
Optimization Test #1 (90 cfm to INJ2 for 4 hours then shut down; ~88% N2, 10% H2, 1% CO2 & LPG)									
2/20/2008	1131	7.1	0.00	0	0.022	70.6		15.1	1010
2/20/2008	1206 Test start								
2/20/2008	1539	0.0	0.84	1.04	10	48.1		22.5	1007

Aerojet GEDIT - Injection Test Input

Phase II Piezometer Monitoring Data

Well ID P5

Depth 28

Date	Time	Well or Injection Gas Sample						Well	Ambient Air
		O ₂ (%)	CO ₂ (%)	Propane (%)	H ₂ (%)	He (ppm)	RH (%)	Pressure (in wc)	Temperature (C°)
2/20/2008	1606 Test End								
2/20/2008	1623	0.0	0.72	1.06	9.4		47.2	22.3	1008
2/21/2008	910	1.0	0.56	0.96	9.3		78.2	10.6	1005
2/22/2008	1036	4.9	0.48	0.54	3.8		83.6	9.7	1003
Optimization Test #2 (30 cfm to INJ2 for 12 hours then shut down; ~88% N2, 10% H2, 1% CO2 & LPG)									
2/25/2008	1845 Test Start								
2/26/2008	653 Test End								
2/26/2008	703	0.0	2.12	0.48	7.4		91.8	3	1017
2/27/2008	1531	2.0	1.36	0.44	3.7		37.1	33	1009
2/28/2008	1051	4.7	1.16	0.36	2		71	15.8	1007
Optimization Test #3A (1 cfm to INJ2; ~88% N2, 10% H2, 1% CO2 & LPG)									
2/29/2008	1319 Test Start								
2/29/2008	1430	7.2	0.86	0.28	1		48.6	23.5	1009
2/29/2008	1518	7.1	0.88	0.28	0.91		53.1	24	1009
3/3/2008	1045	8.2	0.72	0.32	3		66.5	15.2	1019
3/3/2008	1130 Test End								

Aerojet GEDIT - Injection Test Input

Phase II Piezometer Monitoring Data

Well ID P5

Depth 28

Date	Time	Well or Injection Gas Sample						Well	Ambient Air
		O ₂ (%)	CO ₂ (%)	Propane (%)	H ₂ (%)	He (ppm)	RH (%)	Pressure (in wc)	Temperature (C°)
Optimization Test #3B (1 cfm to INJ1, INJ2 & INJ3; ~88% N2, 10% H2, 1% CO2 & LPG)									
3/3/2008	1130 Test Start								
3/4/2008	926	11	0.74	0.2	1.8		76.2	12.2	1013
3/7/2008	1055	11.3	0.32	0.14	1.7		58.3	18.2	1018
3/7/2008	1306 Test End								
Optimization Test #3C (90 cfm to INJ1, INJ2 & INJ3 for 15 minutes then shut down; ~79% N2, 10% H2 & LPG, 1% CO2)									
3/7/2008	1306 Start Pulse								
3/7/2008	1321 End Pulse								
3/7/2008	1334	10.9	0.3	0.16	2		48.7	22.8	1016
3/10/2008	1050	8.7	0.4	0.42	0.22		66.5	16.5	1016
Optimization Test #4 (2, 45-minutes pulses; daily 15-minutes pulses w/30cfh constant flow)									
3/10/2008	1234	8.9	0.48	0.44	0.22		54.9	20.5	1016
3/10/2008	1253	7.7	0.50	1	0.96				
3/10/2008	1318	2.6	0.68	5	5.2		52.8	21.4	1016
3/10/2008	1330	0.8	0.68	7	8.6				
3/10/2008	1347	End pulse							
3/10/2008	1408	0.4	0.90	7	10		49.1	22.6	1015
3/11/2008	913	5.1	0.68	2.5	4.5		68.8	14.7	1017

Aerojet GEDIT - Injection Test Input

Phase II Piezometer Monitoring Data

Well ID P5

Depth 28

Date	Time	Well or Injection Gas Sample						Well	Ambient Air	
		O ₂ (%)	CO ₂ (%)	Propane (%)	H ₂ (%)	He (ppm)	RH (%)	Pressure (in wc)	Temperature (C°)	Barometric pressure (mbar)
3/12/2008	1000	7.0	0.64	2.5	3.7		81.6		12.8	1014
3/13/2008	914	7.8	0.52	2	3.2		84.6		13.8	1011
3/14/2008	1139	8.1	0.52	2	1.9		83.4		13.8	1013
3/14/2008	1214	4.0	0.56	2	6.8		78.8		14.8	1012
3/15/2008	1124	9.6	0.52	1.74	1.1		82.2		11.3	1009
3/16/2008	1111	10.7	0.34	1.38	0.78		75.1		14.3	1009
3/17/2008	923	10.2	0.40	1.76	1.5		81.4		9.1	1014

Optimization Test #5 (20 cfm to INJ2 for 125 minutes while maintaing 30 cfh the rest of the time; ~80% N2, 10% H2 & LPG)										
3/17/2008	1037	Start Test								
3/17/2008	1255	0.1	0.12	9.5	9.9		65.1		17.7	1014
3/8/2008	941	6.0	0.26	5.5	4		71.3		12.9	1016
3/19/2008	959	8.2	0.26	3.5	2.3		82		12.1	1013
3/20/2008	943	9.1	0.26	2.5	1.4		82.7		9.4	1016
3/20/2008	~1100	End Test								

Optimization Test #6 (50 cfh to P4-18 & P4-28; ~80% N2, 10% H2 & LPG)										
3/20/2008	1330	Start Test								
3/21/2008	1004	6.5	0.20	2.5	2.5		83.4		12.0	1020
3/21/2008	1028	6.3	0.18	2.5	2.4					
3/24/2008	1003	3.7	0.22	2.5	2.2		63.0		16.3	1012

Aerojet GEDIT - Injection Test Input

Phase II Piezometer Monitoring Data

Well ID P5

Depth 28

Date	Time	Well or Injection Gas Sample						Well	Ambient Air	
		O ₂ (%)	CO ₂ (%)	Propane (%)	H ₂ (%)	He (ppm)	RH (%)	Pressure (in wc)	Temperature (C°)	Barometric pressure (mbar)
3/26/2008	945	3.0	0.20	2.5	2.4		85.2		10.8	1017
3/28/2008	942	1.6	0.2	2.0	1.5		82.7		10.4	1009
3/31/2008	943	0.1	0.12	14.0	9.1		82.5		9.3	1013
4/2/2008	1041	0.0	0.14	13.5	7.4		86.1		13.6	1008
Optimization Test #7 (20 cfh to P4-18, --28, -38 (60 cfh total); ~80% N2, 10% H2 & LPG)										
4/2/2008	1233 Start Test									
4/4/2008	925	0.3	0.10	12.5	7.0		84.6		12.1	1013
4/7/2008	1352	3.4	0.08	9.5	4.8		64.9		19.2	1012
Optimization Test #7B (30 cfh to P4-18, & P4-28 (60 cfh total); ~80% N2, 10% H2 & LPG)										
4/7/2008	1458 Start Test									
4/9/2008	1036	6.0	0.02	7.0	2.3		78.5		14.4	1009
Optimization Test #7C (50 cfh to P4-18, & P4-28 (100 cfh total); ~79% N2, 10% H2 & LPG, 1% CO2)										
4/10/2009	1121 Start Test									
4/11/2008	1220	6.9	0.06	5.5	2.4		62.7		21.3	1013
4/14/2008	1003	0.9	0.26	12.5	2.8		82.3		15.6	1007
4/16/2008	1015	0.6	0.48	9.5	6.1		82.3		14.5	1011
4/22/2008	1032	3.5	0.26	4.0	2.8		79.9		18.1	1009
4/23/2008	932	0.0	0.22	8.5	0.58		80.4		12.9	1010

Aerojet GEDIT - Injection Test Input

Phase II Piezometer Monitoring Data

Well ID P5

Depth 28

Date	Time	Well or Injection Gas Sample						Well	Ambient Air	
		O ₂ (%)	CO ₂ (%)	Propane (%)	H ₂ (%)	He (ppm)	RH (%)	Pressure (in wc)	Temperature (C°)	Barometric pressure (mbar)
4/25/2008	943	0.0	0.08	9.0	0.10		71.3		18.9	1015
4/29/2008	1055	0.0	0.16	8.5	4.4		62.5		24.9	1007
5/5/2008	1259	0.7	0.22	7.5	4.6		46.2		33.4	1001
5/13/2008	915	0.0	0.90	9.5	2.0		47.2		31.6	1007
5/20/2008	918	0.6	0.24	8.0	1.1		68.8		24.0	1004
5/23/2008	1504	0.3	0.58	8.5	2.5		43.5		33.8	990
5/27/2008	849	0.4	0.78	8.5	5.2		84.5		15.9	1007
6/4/2008	851	0.0	0.20	9.0	4.3		68.6		21.9	1002
6/12/2008	1128	0.0	0.56	9.0	2.5		36.7		38.8	1003
6/20/2008	1002	0.0	0.40	8.5	4.1		51.3		33.2	1005
6/25/2008	1030	0.0	0.16	8.0	4.5		62.5		29.6	1005
7/2/2008	1131	0.0	0.16	8.0	4.4		44.8		33.5	1004
7/7/2008	1120	0	0.16	8	3		41.8		35.1	998
7/18/2008	1048	0	0.2	8	4.3		85.2		24.7	
7/24/2008	1046	0.0	0.24	8.0	4.200		73.2		27.5	1005
7/31/2008	1046	0.0	0.32	8.0	4.600		77.7		26.7	1003
8/7/2008	918	0.0	0.30	8.5	4.2		91.6		21.9	1004
8/12/2008	1022	0.0	0.26	8.5	4.1		62.7		28.9	1002

Aerojet GEDIT - Injection Test Input

Phase II Piezometer Monitoring Data

Well ID P5

Depth 28

Date	Time	Well or Injection Gas Sample						Well	Ambient Air	
		O ₂ (%)	CO ₂ (%)	Propane (%)	H ₂ (%)	He (ppm)	RH (%)	Pressure (in wc)	Temperature (C°)	Barometric pressure (mbar)
Optimization Test #8 (100 cfh of 100% Propane to P4-18, & P4-28 (50 cfh to each point))										
9/8/2008	0905 Test Start									
9/8/2008	1018	5.3	0.52	6.5	0.005					999
9/15/2008	909	5.8	0.76	30	0.002		58.5	24.9		1007
9/29/2008	938	4.6	0.56	30	0.005		61.3	24.2		1006
10/13/2008	1149	7.2	0.44	30	0.005		43.1	30.3		1017
10/20/2008	1117	5.3	0.46	30	0.005		55.1	24.9		1013
11/5/2008	1354	4.6	0.58	30	0.005		79.4	18.7		1016
11/17/2008	1106	3.6	0.62	30	0.010		42.7	30.8		1014
12/1/2008	1108	3.2	0.68	30	0.005		55.3	20.9		1014

Aerojet GEDIT - Injection Test Input

Phase II Piezometer Monitoring Data

Well ID P5

Depth 38

Date	Time	Well or Injection Gas Sample							Well	Ambient Air	
		O ₂ (%)	CO ₂ (%)	Propane (%)	H ₂ (%)	He (ppm)	RH (%)	Pressure (in wc)	Temperature (C°)	Barometric pressure (mbar)	
12/12/2007	1210	19.3	0.34	0	0.002	70,000	82.0	0.02	12.1	1020	
12/12/2007	1534							0.43			
12/12/2007	1627	0.1				2x10 ⁴					
12/12/2007	1635	0.1				2x10 ⁴					
12/12/2007	1642	0.1				2x10 ⁴					
12/13/2007	803	10.1	0.00	0	0.002	2x10 ⁴	86.8		0.7	1016	
12/13/2007	843	3.3	0.00	0	7.0	2x10 ³	72.5		4.5	1016	
12/13/2007	937	9.2	0	0	8.2		60.2		11.5	1016	
12/13/2007	1200	Discovered leak in O2 - all O2 data for 12/13/07 before 1200 invalid									
12/13/2007	1317							0.31			
12/13/2007	1327	0	0	0	8.4		62.8		17.4	1014	
12/13/2007	1442	0	0.14	0.52	0.59		77.1		14.7	1013	
12/13/2007	1522	0	0.44	0.52	0.22		75.2		14.8	1013	
12/13/2007	1556	0	0.40	0.52			74.1		12.8	1013	
12/14/2007	830	0	0.32	0	0.50		70.5	0.03	4.1	1016	
12/21/2007	1203	6.8	0.26	0.10	0.46		88.9	0.03	9.9	1012	
12/26/2007	1228	11.2	0.22	0.06	0.22		84.2	0.04	12.4	1016	
12/26/2007	1612	9.5	0.28	0.06	0.71		82.6	0.02	10.2	1015	
12/27/2007	1016	1.3	0.32	0	7.5		78.2	0.03	6	1018	
12/27/2007	1320	0.8	0.2	0	8.1		86.9		8.5	1016	

Aerojet GEDIT - Injection Test Input

Phase II Piezometer Monitoring Data

Well ID P5

Depth 38

Date	Time	Well or Injection Gas Sample						Well	Ambient Air	
		O ₂ (%)	CO ₂ (%)	Propane (%)	H ₂ (%)	He (ppm)	RH (%)	Pressure (in wc)	Temperature (C°)	Barometric pressure (mbar)
12/27/2007	1440	0.7	0.18	0	8.3		87.8		8.5	1017
12/27/2007	1558	0.6	0.18	0	8.7		90.9	0.04	7.5	1017
1/2/2007	1035	0.2	0.14	0	0.22		52.6	0.02	16.7	1012

Tracer Test #1 (10 cfm to INJ2, ~7% H2)										
1/21/2008	1046 Test start									
1/21/2008	1133	2.7	0.10	0	1.1		84.0	0.06	9.9	1008
1/21/2008	1254	2.5	0.10	0	1.1		85.9	0.07	10.7	1006
1/21/2008	1445	1.9	0.08	0	1.8		84.7	0.09	10.7	1006
1/21/2008	1610	1.7	0.08	0	2.5		89.9	0.06	9.8	1006
1/22/2008	954	1.0	0.08	0	5.7		85.7	0.10	6.8	1011
1/22/2008	1354	0.8	0.04	0	6.1		86.8		6.5	1009
1/23/2008	1021	0.8	0.08	0	6.4		85.1	0.08	8.5	1007
1/23/2008	1113*	0.7								

Tracer Test #2 (20 cfm to INJ2, ~8% H2)										
1/18/2008	1120 Test start									
1/18/2008	1135	2.9	0.24	0	0.60		83.8		12.5	1015
1/18/2008	1217	2.3	0.22	0	0.75		80.0	0.03	13.4	1015
1/18/2008	1318	1.6	0.20	0	2.0		68.6		15.6	1014

Aerojet GEDIT - Injection Test Input

Phase II Piezometer Monitoring Data

Well ID P5

Depth 38

Date	Time	Well or Injection Gas Sample						Well	Ambient Air	
		O ₂ (%)	CO ₂ (%)	Propane (%)	H ₂ (%)	He (ppm)	RH (%)	Pressure (in wc)	Temperature (C°)	Barometric pressure (mbar)
1/18/2008	1351	1.7	0.20	0	2.9		73.8		15.4	1014
1/18/2008	1528	1.3	0.18	0	4.6		50.8	0.03	21.2	1014
1/19/2008	1006	0.7	0.14	0	9.7		72.3	0.00	9.4	1019
1/19/2008	1139*	0.7	0.10	0	8.5		70.0		12.5	1018

Tracer Test #3 (30 cfm to INJ2, ~4% H2)										
1/30/2008	1036 Test start									
1/30/2008	1105	0.0	0	0	1.9		87.6	0.10	9.4	1020
1/30/2008	1218	0.0	0	0	2.6		80.7		11.0	1019
1/30/2008	1418	0.0	0	0	4.0		80.3	0.14	12.8	1018
1/31/2008	942	0.0	0	0	4.2		89.8	0.11	8.4	1019
1/31/2008	1128	0	0	0	3.8		84.1		9.6	1018
1/31/2008	1339	0	0	0	3.8		85.7	0.16	8.7	1016
1/31/2008	1435									
1/31/2008	1509	0	0	0	3.7		87.7	0.04	8.2	1014
1/31/2008	1610	0	0	0	3.9		87.6		8.3	1013

Tracer Test #4 (60 cfm to INJ2, ~7% H2)										
1/28/2008	1236 Test start									
1/28/2008	1254	7.5	0.04	0	0.50		94.1		10.5	1010

Aerojet GEDIT - Injection Test Input

Phase II Piezometer Monitoring Data

Well ID P5

Depth 38

Date	Time	Well or Injection Gas Sample						Well	Ambient Air	
		O ₂ (%)	CO ₂ (%)	Propane (%)	H ₂ (%)	He (ppm)	RH (%)	Pressure (in wc)	Temperature (C°)	Barometric pressure (mbar)
1/28/2008	1410	0.2	0.04	0	5.2		77.0	0.24	13.3	1010
1/28/2008	1549	0.0	0	0	6.1		88.1	0.18	10.5	1011
1/29/2008	754	0.0	0	0	7.3		86.6	0.10	4.9	1016
1/29/2008	Final O2*	0.0								

Tracer Test #5 (90 cfm to INJ2, ~3% H2)										
2/5/2008	1015 Test start									
2/5/2008	1028	1.1	0	0	1.1		73.2	0.28	9.3	1019
2/5/2008	1126	0.0	0	0	3.1		74.9		10.8	1019
2/5/2008	1336	0.0	0	0	4.0		73.7	0.32	12.4	1019
2/5/2008	1504	0.0	0	0	3.7		69.2		14.5	1019
2/5/2008	1548	0.0	0	0	3.5		54.7		18.0	1018

Tracer Test #6 (30 cfm total; 10 cfm to each INJ1, 2, and 3; ~8% H2)										
2/7/2008	1500 Test start									
2/7/2008	1528	0.0	0	0	1.1		45		22.0	1016
2/7/2008	1617	0.0	0	0	0.98		44.9		21.3	1016
2/8/2008	1005	0.0	0	0	5.3		62.5		11.3	1017
2/8/2008	1056	0.0	0	0	5.1		76.9		11.0	1017

Aerojet GEDIT - Injection Test Input

Phase II Piezometer Monitoring Data

Well ID P5

Depth 38

Date	Time	Well or Injection Gas Sample						Well	Ambient Air
		O ₂ (%)	CO ₂ (%)	Propane (%)	H ₂ (%)	He (ppm)	RH (%)	Pressure (in wc)	Temperature (C°)

Tracer Test #7 (60 cfm total; 20 cfm to each INJ1, 2, and 3, ~5% H2)										
1/17/2008	900 Test start									
1/17/2008	953	11.7	0.08	0	0.22		81.2	0.00	7.3	1015
1/17/2008	1024	11.7	0.06	0	0.22		93.9	0.02	8.2	1015
1/17/2008	1155	11.7	0.06	0	0.22		87.7	0.01	10.0	1015
1/17/2008	1351	10.4	0.24	0	1.4		90.8		12.5	1013
1/17/2008	1513	8.8	0.26	0	2.3		75.5	0.04	15.8	1012

Tracer Test #8 (90 cfm total; 30 cfm each to INJ1, 2, and 3; ~4.5% H2)										
2/6/2008	1000 Test start									
2/6/2008	1030	0.0	0	0	1.4		73.1	0.18	11.3	1020
2/6/2008	1141	0.0	0	0	1.1		68.9		12.7	1020
2/6/2008	1241	0.0	0	0	1.3		66.8		14.0	1019
2/6/2008	1430	0.0	0	0	2.5		59.3	0.18	16.2	1017
2/6/2008	1533	0.0	0	0	2.7		59.1		17.0	1017
2/6/2008	1626	0.0	0	0	2.9		60.6		16.9	1017

Optimization Test #1 (90 cfm to INJ2 for 4 hours then shut down; ~88% N2, 10% H2, 1% CO2 & LPG)										
2/20/2008	1133	7.8	0.00	0	0.046		71.2		15.1	1010
2/20/2008	1206 Test start									

Aerojet GEDIT - Injection Test Input

Phase II Piezometer Monitoring Data

Well ID P5

Depth 38

Date	Time	Well or Injection Gas Sample						Well	Ambient Air	
		O ₂ (%)	CO ₂ (%)	Propane (%)	H ₂ (%)	He (ppm)	RH (%)	Pressure (in wc)	Temperature (C°)	Barometric pressure (mbar)
2/20/2008	1540	0.0	0.80	1.02	11		49.8		22.7	1007
2/20/2008	1606 Test End									
2/20/2008	1624	0.0	0.68	1	10		47.4		22.5	1008
2/21/2008	912	4.8	0.46	0.7	7.4		78.3		10.6	1005
2/22/2008	1038	9.2	0.42	0.42	3.5		84.8		9.7	1003

Optimization Test #2 (30 cfm to INJ2 for 12 hours then shut down; ~88% N2, 10% H2, 1% CO2 & LPG)										
2/25/2008	1845 Test Start									
2/26/2008	653 Test End									
2/26/2008	704	0.2	2.12	0.56	7		91.2		3.1	1017
2/27/2008	1532	6.0	1.1	0.32	3.2		33.1		33.8	1009
2/28/2008	1052	7.5	0.92	0.34	2.1		69.5		15.8	1008
Optimization Test #3A (1 cfm to INJ2; ~88% N2, 10% H2, 1% CO2 & LPG)										
2/29/2008	1319 Test Start									
2/29/2008	1432	8.8	0.70	0.26	1		51		23.7	1009
2/29/2008	1519	8.8	0.7	0.26	0.87		51.9		24.8	1009
3/3/2008	1046	8.3	0.64	0.24	0.1		66.9		15.3	1019
3/3/2008	1130 Test End									

Aerojet GEDIT - Injection Test Input

Phase II Piezometer Monitoring Data

Well ID P5

Depth 38

Date	Time	Well or Injection Gas Sample						Well	Ambient Air
		O ₂ (%)	CO ₂ (%)	Propane (%)	H ₂ (%)	He (ppm)	RH (%)	Pressure (in wc)	Temperature (C°)
Optimization Test #3B (1 cfm to INJ1, INJ2 & INJ3; ~88% N2, 10% H2, 1% CO2 & LPG)									
3/3/2008	1130	Test Start							
3/4/2008	927	8.5	0.72	0.22	0.22		75.2	12.3	1013
3/7/2008	1056	9.5	0.46	0.16	0.046		58.7	18.2	1018
3/7/2008	1306	Test End							
Optimization Test #3C (90 cfm to INJ1, INJ2 & INJ3 for 15 minutes then shut down; ~79% N2, 10% H2 & LPG, 1% CO2)									
3/7/2008	1306	Start Pulse							
3/7/2008	1321	End Pulse							
3/7/2008	1336	9.4	0.44	0.18	0.046		49.3	22.6	1016
3/10/2008	1052	9.6	0.5	0.42	0.022		66.9	16.5	1016
Optimization Test #4 (2, 45-minutes pulses; daily 15-minutes pulses w/30cfh constant flow)									
3/10/2008	1319	9.5	0.60	0.42	0.022		53.5	21.4	1016
3/10/2008	1347	End pulse							
3/10/2008	1409	9.0	0.56	0.68	0.77		49.2	22.6	1015
3/11/2008	921	7.8	0.58	1.42	2		67.8	15.3	1017
3/12/2008	1001	7.6	0.54	1.44	1.5		82.5	12.9	1014
3/13/2008	916	7.7	0.48	1.34	1		83.9	13.9	1011
3/14/2008	1140	7.5	0.48	1.38	0.63		82.5	13.9	1013

Aerojet GEDIT - Injection Test Input

Phase II Piezometer Monitoring Data

Well ID P5

Depth 38

Date	Time	Well or Injection Gas Sample						Well	Ambient Air
		O ₂ (%)	CO ₂ (%)	Propane (%)	H ₂ (%)	He (ppm)	RH (%)	Pressure (in wc)	Temperature (C°)
3/14/2008	1215	7.2	0.46	1.42	0.6		78	14.7	1012
3/15/2008	1125	7.8	0.50	1.16	0.5		81.3	11.2	1009
3/16/2008	1112	7.7	0.36	1.68	0.57		75.3	14.3	1009
3/17/2008	924	8.2	0.46	1.74	0.5		81.5	9.2	1014

Optimization Test #5 (20 cfh to INJ2 for 125 minutes while maintaing 30 cfh the rest of the time; ~80% N2, 10% H2 & LPG)									
3/17/2008	1037	Start Test							
3/17/2008	1254	6.0	0.36	4.5	2.1		61.9	17.7	1014
3/8/2008	943	5.2	0.42	4.5	2.6		78	13.1	1016
3/19/2008	1000	4.7	0.40	4.5	1.4		81.1	12.1	1013
3/20/2008	945	5.0	0.42	4.5	0.5		82.2	9.5	1016
3/20/2008	~1100	End Test							

Optimization Test #6 (50 cfh to P4-18 & P4-28; ~80% N2, 10% H2 & LPG)									
3/20/2008	1330	Start Test							
3/21/2008	1010	5.1	0.38	4.0	0.10		82.1	12.4	1020
3/24/2008	1005	5.4	0.46	3.5	0.046		64.8	16.1	1012
3/26/2008	946	5.4	0.48	3.5	0.022		82.8	10.8	1017
3/28/2008	943	5.4	0.5	3.0	0.022		84.3	10.4	1009
3/31/2008	945	2.6	0.42	7.0	1.8		85.4	9.4	1013
4/2/2008	1042	0.9	0.40	10.5	1.8		86.1	13.9	1008

Aerojet GEDIT - Injection Test Input

Phase II Piezometer Monitoring Data

Well ID P5

Depth 38

Date	Time	Well or Injection Gas Sample						Well	Ambient Air
		O ₂ (%)	CO ₂ (%)	Propane (%)	H ₂ (%)	He (ppm)	RH (%)	Pressure (in wc)	Temperature (C°)
Optimization Test #7 (20 cfh to P4-18, --28, -38 (60 cfh total); ~80% N2, 10% H2 & LPG)									
4/2/2008	1233	Start Test							
4/4/2008	926	0.4	0.36	10.5	5.8		84.2	12.2	1013
4/7/2008	1353	1.2	0.28	8.5	4.7		66.5	19.2	1012
Optimization Test #7B (30 cfh to P4-18, & P4-28 (60 cfh total); ~80% N2, 10% H2 & LPG)									
4/7/2008	1458	Start Test							
4/9/2008	1040	1.5	0.24	9.0	0.1		77.2	14.3	1009
Optimization Test #7C (50 cfh to P4-18, & P4-28 (100 cfh total); ~79% N2, 10% H2 & LPG, 1% CO2)									
4/10/2009	1121	Start Test							
4/11/2008	1221	1.7	0.32	9.0	0.1		62.6	21.4	1013
4/14/2008	1005	0.6	0.30	10.0	0.7		82.9	15.7	1007
4/16/2008	1016	0.0	0.30	11.0	0.50		84.3	14.7	1011
4/22/2008	1034	1.1	0.38	6.5	0.10		79.4	18.1	1009
4/23/2008	933	1.2	0.40	7.0	0.22		80.5	12.8	1010
4/25/2008	944	0.5	0.36	8.0	0.10		74.4	18.8	1015
4/29/2008	1056	0.0	0.40	8.5	0.46		63.4	25.0	1007
5/5/2008	1301	0.2	0.40	8.0	0.1		51.8	33.4	1001
5/13/2008	916	0.0	0.46	8.5	0.046		45.4	32.6	1007

Aerojet GEDIT - Injection Test Input

Phase II Piezometer Monitoring Data

Well ID P5

Depth 38

Date	Time	Well or Injection Gas Sample						Well	Ambient Air	
		O ₂ (%)	CO ₂ (%)	Propane (%)	H ₂ (%)	He (ppm)	RH (%)	Pressure (in wc)	Temperature (C°)	Barometric pressure (mbar)
5/20/2008	920	0.0	0.48	8.5	0.10		68.7		23.5	1004
5/23/2008	1505	0.2	0.40	8.5	0.10		50.8		32.7	990
5/27/2008	850	0.0	0.58	8.5	0.10		84.0		16.1	1007
6/4/2008	853	0.0	0.44	8.0	0.22		67.9		22.8	1002
6/12/2008	1131	0.1	0.46	8.5	0.046		37.7		39.1	1003
6/20/2008	1005	0.0	0.46	8.5	0.540		47.3		34.3	1005
6/25/2008	1032	0.0	0.44	8.5	0.22		56.4		30.3	1005
7/2/2008	1132	0.0	0.42	8.0	0.50		46.6		33.5	1004
7/7/2008	1121	0	0.36	8	0.5		43.6		35.2	998
7/18/2008	1049	0	0.46	8	0.1		75.9		24.9	
7/24/2008	1047	0.0	0.48	8.0	0.220		68.9		27.5	1005
7/31/2008	1042	0.0	0.54	8.0	0.220		70.5		26.5	1003
8/7/2008	919	0.0	0.60	8.0	0.22		90.6		22.0	1004
8/12/2008	1023	6.0	0.60	8.5	0.51		60.5		29.0	1002
Optimization Test #8 (100 cfh of 100% Propane to P4-18, & P4-28 (50 cfh to each point)										
9/8/2008	0905 Test Start									
9/8/2008	1021	6.2	0.58	6.5	0.005					999
9/15/2008	910	0.9	0.96	30	0.005		59.3		24.9	1007
9/29/2008	929	0.1	0.46	30	0.005		62.8		23.6	1006
10/13/2008	1152	0.6	0.34	30	0.005		42.7		30.4	1017

Aerojet GEDIT - Injection Test Input

Phase II Piezometer Monitoring Data

Well ID P5

Depth 38

Date	Time	Well or Injection Gas Sample						Well	Ambient Air	
		O ₂ (%)	CO ₂ (%)	Propane (%)	H ₂ (%)	He (ppm)	RH (%)	Pressure (in wc)	Temperature (C°)	Barometric pressure (mbar)
10/20/2008	1118	0.4	0.36	30	0.005		54.3		25.1	1013
11/5/2008	1346	0.1	0.38	30	0.005		65.9		19.0	1016
11/17/2008	1108	0.0	0.34	30	0.010		41.4		30.4	1014
12/1/2008	1109	0.0	0.30	30	0.005		55.6		21.5	1014

Aerojet GEDIT - Injection Test Input

Phase II Piezometer Monitoring Data

Well ID P5

Depth 48

Date	Time	Well or Injection Gas Sample							Well	Ambient Air	
		O ₂ (%)	CO ₂ (%)	Propane (%)	H ₂ (%)	He (ppm)	RH (%)	Pressure (in wc)	Temperature (C°)	Barometric pressure (mbar)	
12/12/2007	1211	19.1	0.00	0	0.002	80,000	82.2	0.02	12.1	1020	
12/12/2007	1533							0.33			
12/12/2007	1628	12.0				3x10^4					
12/12/2007	1634	7.7				3x10^4					
12/12/2007	1642	5.1				2x10^4					
12/13/2007	804	13.7	0.00	0	0.002	2x10^4	86.4		0.8	1016	
12/13/2007	845	9.0	0.00	0	0.22	2x10^4	71.7		4.7	1016	
12/13/2007	938	13.4	0	0	0.46		61.2		11.6	1016	
12/13/2007	1200	Discovered leak in O2 - all O2 data for 12/13/07 before 1200 invalid									
12/13/2007	1317							0.18			
12/13/2007	1327	0	0	0	8.0		63.3		17.5	1014	
12/13/2007	1446	0	0	0	8.9		79.7		14.0	1013	
12/13/2007	1523	0	0	0	8.8		75.4		14.7	1013	
12/13/2007	1557	0	0	0.02			76.3		12.8	1013	
12/14/2007	831	0	0	0.40	2.3		71.5		4.1	1016	
12/21/2007	1204	13.8	0	0	0.57		91.3	0.02	9.8	1012	
12/26/2007	1230	14.4	0	0	0.22		84.1	0.01	13.2	1016	
12/26/2007	1614	13.4	0	0.02	0.46		82.1	0.04	10.1	1015	
12/27/2007	1018	13.5	0	0.02	0.5		80.1	0.04	5.9	1018	
12/27/2007	1322	14.8	0	0	0.46		85.8		8.6	1016	

Aerojet GEDIT - Injection Test Input

Phase II Piezometer Monitoring Data

Well ID P5

Depth 48

Date	Time	Well or Injection Gas Sample						Well	Ambient Air	
		O ₂ (%)	CO ₂ (%)	Propane (%)	H ₂ (%)	He (ppm)	RH (%)	Pressure (in wc)	Temperature (C°)	Barometric pressure (mbar)
12/27/2007	1442	13.7	0	0.02	0.46		87.1		8.7	1017
12/27/2007	1600	13.6	0	0.02	0.63		89.2	0.04	7.4	1017
1/2/2008	1037	11.5	0	0	0.22		54.2	0.03	16.6	1012

Tracer Test #1 (10 cfm to INJ2, ~7% H2)										
1/21/2008	1046 Test start									
1/21/2008	1134	5.7	0	0	2.4		84.8	0.06	9.9	1008
1/21/2008	1255	5.9	0	0	2.1		88.2	0.09	10.7	1006
1/21/2008	1446	6.3	0	0	1.8		85.7	0.09	10.9	1006
1/21/2008	1611	6.5	0	0	1.7		88.4	0.06	9.9	1006
1/22/2008	955	7.7	0	0	0.95		86.3	0.02	6.8	1011
1/22/2008	1356	7.4	0	0	1.1		87.5		8.6	1009
1/23/2008	1024	8.7	0.08	0	0.95		86.4	0.04	8.3	1007
1/23/2008	1114*	8.7								

Tracer Test #2 (20 cfm to INJ2, ~8% H2)										
1/18/2008	1120 Test start									
1/18/2008	1136	9.3	0	0	1.0		84.1		12.6	1015
1/18/2008	1218	8.7	0	0	1.2		82.6	0.04	13.4	1015
1/18/2008	1319	8.4	0	0	1.2		69.3		15.7	1014

Aerojet GEDIT - Injection Test Input

Phase II Piezometer Monitoring Data

Well ID P5

Depth 48

Date	Time	Well or Injection Gas Sample						Well	Ambient Air	
		O ₂ (%)	CO ₂ (%)	Propane (%)	H ₂ (%)	He (ppm)	RH (%)	Pressure (in wc)	Temperature (C°)	Barometric pressure (mbar)
1/18/2008	1352	8.4	0	0	1.3		81.5		15.4	1014
1/18/2008	1529	7.9	0	0	1.2		53.7	0.04	21.9	1014
1/19/2008	1009	7.0	0	0	1.9		75.2	0.01	9.4	1019
1/19/2008	1141*	6.8	0	0	2.4		77.0		12.5	1018

Tracer Test #3 (30 cfm to INJ2, ~4% H2)										
1/30/2008	1036 Test start									
1/30/2008	1107	0.1	0	0	3.4		88.4	0.08	9.7	1020
1/30/2008	1220	0.1	0	0	3.2		81.8		11.0	1019
1/30/2008	1419	0.1	0	0	3.3		82.8	0.11	13.0	1018
1/31/2008	945	0.0	0	0	4.0		91.9	0.10	8.5	1019
1/31/2008	1129	0	0	0	3.5		87.1		9.6	1018
1/31/2008	1340	0	0	0	3.5		86.0	0.22	8.7	1016
1/31/2008	1435									
1/31/2008	1511	0	0	0	3.0		88.2	0.03	8.2	1014

Tracer Test #4 (60 cfm to INJ2, ~7% H2)										
1/28/2008	1236 Test start									
1/28/2008	1256	9.7	0	0	0.022		93.4		10.5	1010
1/28/2008	1411	5.0	0	0	0.10		78.8	0.16	13.3	1010

Aerojet GEDIT - Injection Test Input

Phase II Piezometer Monitoring Data

Well ID P5

Depth 48

Date	Time	Well or Injection Gas Sample						Well	Ambient Air	
		O ₂ (%)	CO ₂ (%)	Propane (%)	H ₂ (%)	He (ppm)	RH (%)	Pressure (in wc)	Temperature (C°)	Barometric pressure (mbar)
1/28/2008	1551	4.3	0	0	1.4		87.1	0.10	11.0	1011
1/29/2008	756	0.0	0	0	7.6		86.9	0.13	4.9	1016
1/29/2008	Final O2*	0.0								

Tracer Test #5 (90 cfm to INJ2, ~3% H2)										
2/5/2008	1015 Test start									
2/5/2008	1030	3.4	0	0	0.10		74.9	0.16	9.2	1019
2/5/2008	1128	4.0	0	0	0.10		76.8		10.8	1019
2/5/2008	1337	1.3	0	0	2.3		71.7	0.22	12.4	1019
2/5/2008	1505	0.5	0	0	3.0		62.1		14.5	1019
2/5/2008	1549	0.3	0	0	3.0		51.4		18.0	1019

Tracer Test #6 (30 cfm total; 10 cfm to each INJ1, 2, and 3; ~8% H2)										
2/7/2008	1500 Test start									
2/7/2008	1529	0.2	0.04	0	1.6		41.9		22.1	1016
2/7/2008	1618	0.2	0.04	0	1.5		43.5		21.2	1016
2/8/2008	1006	0.0	0	0	1.3		64.1		11.1	1017
2/8/2008	1057	0.0	0	0	1.3		73.6		11.0	1017

Aerojet GEDIT - Injection Test Input

Phase II Piezometer Monitoring Data

Well ID P5

Depth 48

Date	Time	Well or Injection Gas Sample						Well	Ambient Air	
		O ₂ (%)	CO ₂ (%)	Propane (%)	H ₂ (%)	He (ppm)	RH (%)	Pressure (in wc)	Temperature (C°)	Barometric pressure (mbar)
Tracer Test #7 (60 cfm total; 20 cfm to each INJ1, 2, and 3, ~5% H2)										
1/17/2008	900 Test start									
1/17/2008	955	14.3	0	0	0.22		80.9	0.02	7.3	1015
1/17/2008	1026	12.5	0	0	0.022		86.3	0.02	8.2	1015
1/17/2008	1157	11.8	0	0	0.22		87.6	0.01	10.1	1015
1/17/2008	1353	11.3	0	0	0.22		88.6		12.7	1013
1/17/2008	1515	10.9	0	0	0.22		69.2	0.05	17.1	1012
Tracer Test #8 (90 cfm total; 30 cfm each to INJ1, 2, and 3; ~4.5% H2)										
2/6/2008	1000 Test start									
2/6/2008	1032	0.4	0	0	1.6		72.9	0.14	11.2	1020
2/6/2008	1143	0.4	0	0	1.5		68.2		12.7	1020
2/6/2008	1242	0.3	0	0	1.5		65.3		14.1	1019
2/6/2008	1437	0.4	0	0	1.7		57.8	0.15	16.0	1017
2/6/2008	1534	0.4	0	0	1.6		57		17.0	1017
2/6/2008	1627	0.4	0	0	1.6		55.8		17.3	1017
Optimization Test #1 (90 cfm to INJ2 for 4 hours then shut down; ~88% N2, 10% H2, 1% CO2 & LPG)										
2/20/2008	1134	9	0.28	0	0.046		70.3		15.2	1010
2/20/2008	1206 Test start									

Aerojet GEDIT - Injection Test Input

Phase II Piezometer Monitoring Data

Well ID P5

Depth 48

Date	Time	Well or Injection Gas Sample						Well	Ambient Air
		O ₂ (%)	CO ₂ (%)	Propane (%)	H ₂ (%)	He (ppm)	RH (%)	Pressure (in wc)	Temperature (C°)
2/20/2008	1541	2.6	0.00	0.54	5.9		44.9	23.1	1007
2/20/2008	1606 Test End								
2/20/2008	1629	3.3	0.04	0.46	4.8		43.2	22.8	1008
2/21/2008	913	8.5	0.48	0	0.5		80.1	10.6	1005
2/22/2008	1039	9.3	0.50	0	0.5		84.1	9.7	1003

Optimization Test #2 (30 cfm to INJ2 for 12 hours then shut down; ~88% N2, 10% H2, 1% CO2 & LPG)									
2/25/2008	1845 Test Start								
2/26/2008	653 Test End								
2/26/2008	706	7.5	0.3	0.4	1.3		90.6	3.2	1017
2/27/2008	1534	10.0	0.46	0	0.046		32.2	34.6	1009
2/28/2008	1053	10.6	0.38	0	0.046		68.1	15.8	1007
Optimization Test #3A (1 cfm to INJ2; ~88% N2, 10% H2, 1% CO2 & LPG)									
2/29/2008	1319 Test Start								
2/29/2008	1433	10.6	0.26	0.02	0.046		54.3	23.8	1009
3/3/2008	1048	10.8	0.28	0	0.022		66.9	15.4	1019
3/3/2008	1130 Test End								

Aerojet GEDIT - Injection Test Input

Phase II Piezometer Monitoring Data

Well ID P5

Depth 48

Date	Time	Well or Injection Gas Sample						Well	Ambient Air	
		O ₂ (%)	CO ₂ (%)	Propane (%)	H ₂ (%)	He (ppm)	RH (%)	Pressure (in wc)	Temperature (C°)	Barometric pressure (mbar)
Optimization Test #3B (1 cfm to INJ1, INJ2 & INJ3; ~88% N2, 10% H2, 1% CO2 & LPG)										
3/3/2008	1130	Test Start								
3/4/2008	928	11.2	0.4	0	0.022			75.3	12.5	1013
3/7/2008	1058	11.3	0.22	0.02	0.022			58.1	18.2	1018
3/7/2008	1306	Test End								
Optimization Test #3C (90 cfm to INJ1, INJ2 & INJ3 for 15 minutes then shut down; ~79% N2, 10% H2 & LPG, 1% CO2)										
3/7/2008	1306	Start Pulse								
3/7/2008	1321	End Pulse								
3/7/2008	1337	11	0.18	0.02	0.01			47.2	22.4	1016
3/10/2008	1053	11.8	0.28	0	0.022			67.4	16.5	1016
Optimization Test #4 (2, 45-minutes pulses; daily 15-minutes pulses w/30cfh constant flow)										
3/10/2008	1347	End pulse								
3/10/2008	1410	11.7	0.26	0.02	0.01			50.6	22.6	1015
3/11/2008	923	12.0	0.36	0.06	0.046			69.3	15.4	1017
3/12/2008	1003	12.4	0.40	0	0.022			82.3	12.9	1014
3/13/2008	917	12.2	0.36	0	0.022			85.6	13.9	1011
3/14/2008	1142	12.0	0.36	0	0.022			83	14	1013
3/14/2008	1217	11.8	0.30	0	0.022			79.7	14.7	1012

Aerojet GEDIT - Injection Test Input

Phase II Piezometer Monitoring Data

Well ID P5

Depth 48

Date	Time	Well or Injection Gas Sample						Well	Ambient Air
		O ₂ (%)	CO ₂ (%)	Propane (%)	H ₂ (%)	He (ppm)	RH (%)	Pressure (in wc)	Temperature (C°)
3/15/2008	1126	12.0	0.42	0	0.022		82.4	11.2	1009
3/16/2008	1113	11.6	0.26	0.04	0.022		75.7	14.2	1009
3/17/2008	926	12.8	0.32	0.04	0.01		81.7	9.3	1014

Optimization Test #5 (20 cfm to INJ2 for 125 minutes while maintaing 30 cfh the rest of the time; ~80% N2, 10% H2 & LPG)									
3/17/2008	1037	Start Test							
3/17/2008	1258	10.8	0.16	0.1	0.022		61.2	17.7	1014
3/8/2008	944	11.4	0.32	0.06	0.022		78.4	13.1	1016
3/19/2008	1001	11.3	0.30	0.06	0.022		82	12.3	1013
3/20/2008	946	10.8	0.26	0.16	0.01		82.6	9.6	1016
3/20/2008	~1100	End Test							

Optimization Test #6 (50 cfh to P4-18 & P4-28; ~80% N2, 10% H2 & LPG)									
3/20/2008	1330	Start Test							
3/21/2008	1012	6.9	0.26	0.06	0.68		81.0	12.5	1020
3/24/2008	1006	9.4	0.30	0.78	0.022		66.7	16.0	1012
3/26/2008	948	8.9	0.28	1.36	0.022		82.5	10.9	1017
3/28/2008	945	9.2	0.3	1.26	0.022		86.1	10.5	1009
3/31/2008	946	8.2	0.26	2.0	0.022		85.0	9.6	1013
4/2/2008	1043	6.7	0.22	2.5	0.046		87.1	14.2	1008

Aerojet GEDIT - Injection Test Input

Phase II Piezometer Monitoring Data

Well ID P5

Depth 48

Date	Time	Well or Injection Gas Sample						Well	Ambient Air
		O ₂ (%)	CO ₂ (%)	Propane (%)	H ₂ (%)	He (ppm)	RH (%)	Pressure (in wc)	Temperature (C°)
Optimization Test #7 (20 cfh to P4-18, --28, -38 (60 cfh total); ~80% N2, 10% H2 & LPG)									
4/2/2008	1233	Start Test							
4/4/2008	927	5.1	0.20	4.5	0.046		86.2	12.3	1013
4/7/2008	1354	6.1	0.36	4.0	0.046		67.7	19.1	1012
Optimization Test #7B (30 cfh to P4-18, & P4-28 (60 cfh total); ~80% N2, 10% H2 & LPG)									
4/7/2008	1458	Start Test							
4/9/2008	1043	6.9	0.36	3.5	0.005		77.5	14.2	1009
Optimization Test #7C (50 cfh to P4-18, & P4-28 (100 cfh total); ~79% N2, 10% H2 & LPG, 1% CO2)									
4/10/2009	1121	Start Test							
4/11/2008	1222	7.1	0.46	3.5	0.046		61.7	21.5	1013
4/14/2008	1006	6.1	0.48	4.5	0.022		84.6	15.7	1007
4/16/2008	1017	4.1	0.42	7.0	0.046		84.2	14.9	1011
4/22/2008	1035	3.0	0.44	8.5	0.010		78.7	18.7	1009
4/23/2008	934	3.0	0.42	8.5	0.046		81.4	12.7	1010
4/25/2008	945	1.9	0.28	8.5	0.046		73.9	18.8	1015
4/29/2008	1057	1.6	0.36	9.0	0.10		26.2	25.2	1007
5/5/2008	1303	1.6	0.42	8.5	0.1		33.1	39.1	1001
5/13/2008	919	1.0	0.46	8.5	0.046		38.7	33.1	1007

Aerojet GEDIT - Injection Test Input

Phase II Piezometer Monitoring Data

Well ID P5

Depth 48

Date	Time	Well or Injection Gas Sample							Well	Ambient Air
		O ₂ (%)	CO ₂ (%)	Propane (%)	H ₂ (%)	He (ppm)	RH (%)	Pressure (in wc)	Temperature (C°)	Barometric pressure (mbar)
5/20/2008	921	0.9	0.42	8.5	0.10			68.1	23.4	1004
5/23/2008	1507	0.4	0.44	8.5	0.10			42.6	32.1	990
5/27/2008	852	0.4	0.66	9.0	0.10			84.9	16.3	1007
6/4/2008	854	0.6	0.66	8.0	0.10			67.0	23.4	1002
6/12/2008	1134	0.2	0.66	8.0	0.046			32.5	39.4	1003
6/20/2008	1007	0.3	0.76	8.0	0.046			40.2	35.5	1005
6/25/2008	1033	0.3	0.80	7.5	0.10			53.5	30.8	1005
7/2/2008	1133	0.3	0.84	7.5	0.10			48.1	33.0	1004
7/7/2008	1123	0.2	0.78	7.5	0.046			44	35.3	998
7/18/2008	1050	0.1	0.96	7.5	0.1			82.4	25	
7/24/2008	1048	0.0	0.98	7.0	0.100			70.7	27.7	1005
7/31/2008	1044	0.0	1.04	7.0	0.100			77.3	26.6	1003
8/7/2008	921	0.0	1.10	7.5	0.046			89.0	22.3	1004
8/12/2008	1026	0.0	1.04	7.5	0.100			64.1	28.8	1002
Optimization Test #8 (100 cfh of 100% Propane to P4-18, & P4-28 (50 cfh to each point)										
9/8/2008	0905 Test Start									
9/8/2008	1025	6.2	0.64	6.54	0.005					999
9/15/2008	911	0.5	1.16	30	0.005			58.8	24.8	1007
9/29/2008	930	0.0	1.28	30	0.005			61.4	23.0	1006
10/13/2008	1153	0.2	1.02	30	0.005			42.7	30.3	1017

Aerojet GEDIT - Injection Test Input

Phase II Piezometer Monitoring Data

Well ID P5

Depth 48

Date	Time	Well or Injection Gas Sample						Well	Ambient Air	
		O ₂ (%)	CO ₂ (%)	Propane (%)	H ₂ (%)	He (ppm)	RH (%)	Pressure (in wc)	Temperature (C°)	Barometric pressure (mbar)
10/20/2008	1119	0.1	1.04	30	0.010		53.4		25.3	1013
11/5/2008	1349	0.0	0.52	30	0.005		63.3		18.9	1016
11/17/2008	1109	0.0	0.70	30	0.010		46.8		29.6	1014
12/1/2008	1110	0.0	0.66	30	0.005		54.1		21.8	1014

Aerojet GEDIT - Injection Test Input

Phase II Piezometer Monitoring Data

Well ID P6

Depth 18

Date	Time	Well or Injection Gas Sample						Well	Ambient Air		
		O ₂ (%)	CO ₂ (%)	Propane (%)	H ₂ (%)	He (ppm)	RH (%)	Pressure (in wc)	Temperature (C°)	Barometric pressure (mbar)	
12/12/2007	1153	20.1	0.06	0	0.002	40,000	87.3	0.04	11.5	1020	
12/12/2007	1537							0.15			
12/13/2007	903	10.6	0	0	1.5		77.2		7.2	1016	
12/13/2007	957	12.0	0	0	6.4		69.8		11.7	1016	
12/13/2007	1200	Discovered leak in O2 - all O2 data for 12/13/07 before 1200 invalid									
12/13/2007	1342	0	0.04	0	8.5		77.9		16.8	1013	
12/13/2007	1506	0	0	0.24	5.3		90.0		13.5	1013	
12/13/2007	1538	0	0.02	0.48	1.5		85.3		12.8	1013	
12/14/2007	847	0	0.16	0.10	0.77		65.5	0.04	7.3	1016	
12/21/2007	1209	10.2	0.12	0.08	0.46		88.9	0.02	9.9	1012	
12/26/2007	1235	15.2	0.14	0.04	0.022		76	0.02	14.2	1016	
12/27/2007	1023	0.4	0.2	0	9.1		75.3	0.04	6	1018	
12/27/2007	1325	0.3	0.1	0	9.2		80.9		8.9	1016	
12/27/2007	1445	0.2	0.1	0	9.5		85.6		8.6	1017	
12/27/2007	1607	0.2	0.1	0	9.6		83.4	0.04	7.4	1017	
1/2/2008	1040	0.2	0.1	0	0.22		65	0.02	16.1	1012	

Tracer Test #1 (10 cfm to INJ2, ~7% H2)										
1/21/2008	1046 Test start									
1/21/2008	1211	1.3	0	0	0.046		82.6	0.05	10.0	1007

Aerojet GEDIT - Injection Test Input

Phase II Piezometer Monitoring Data

Well ID P6

Depth 18

Date	Time	Well or Injection Gas Sample						Well	Ambient Air	
		O ₂ (%)	CO ₂ (%)	Propane (%)	H ₂ (%)	He (ppm)	RH (%)	Pressure (in wc)	Temperature (C°)	Barometric pressure (mbar)
1/21/2008	1312	1.2	0	0	0.46		80.6		9.5	1006
1/21/2008	1508	1.2	0	0	2.4		81.1		11.1	1006
1/22/2008	1000	1.0	0.02	0	6.5		85.4	0.08	6.8	1011
1/22/2008	1403	0.9	0	0	6.5		83.3		8.7	1009
1/23/2008	1025	1.1	0	0	6.8		86.6	0.07	8.2	1007
1/23/2008	1118*	0.6								

Tracer Test #2 (20 cfm to INJ2, ~8% H2)										
1/18/2008	1120 Test start									
1/18/2008	1201	1.0	0.04	0	0.046		74.7		13.2	1015
1/18/2008	1304	0.9	0.02	0	1.2		67.1		14.7	1014
1/18/2008	1353	1.1	0.02	0	3.1		70.9		15.5	1014
1/18/2008	1532	0.9	0	0	4.6		50.7	0.04	22.9	1014
1/19/2008	1010	0.9	0.06	0	11.0		67.1	0.02	9.4	1019
1/19/2008	1145*	0.7	0.02	0	9.6		68.6		12.7	1018

Tracer Test #3 (30 cfm to INJ2, ~4% H2)										
1/30/2008	1036 Test start									
1/30/2008	1110	0.0	0	0	0.10		88.2	0.09	9.8	1020
1/30/2008	1221	0.0	0	0	1.9		82.4		11.1	1019

Aerojet GEDIT - Injection Test Input

Phase II Piezometer Monitoring Data

Well ID P6

Depth 18

Date	Time	Well or Injection Gas Sample						Well	Ambient Air	
		O ₂ (%)	CO ₂ (%)	Propane (%)	H ₂ (%)	He (ppm)	RH (%)	Pressure (in wc)	Temperature (C°)	Barometric pressure (mbar)
1/30/2008	1422	0.0	0	0	3.8		77.9	0.10	13.1	1018
1/31/2008	949	0.0	0	0	4.2		86.4	0.16	8.6	1019
1/31/2008	1130	0	0	0	3.8		85.1		9.6	1018
1/31/2008	1344	0	0	0	3.8		79.8	0.13	8.8	1016
1/31/2008	1435									
1/31/2008	1514	0	0	0	3.8		86.9	0.04	8.2	1014

Tracer Test #4 (60 cfm to INJ2, ~7% H2)										
1/28/2008	1236 Test start									
1/28/2008	1302	2.2	0	0	0.022		90.1		10.4	1010
1/28/2008	1412	0.4	0	0	4.1		79.4	0.14	13.3	1011
1/28/2008	1553	0.0	0	0	5.9		87.6	0.18	11.7	1011
1/29/2008	756	0.0	0	0	7.4		87.5	0.08	4.8	1016
1/29/2008	Final O2*									

Tracer Test #5 (90 cfm to INJ2, ~3% H2)										
2/5/2008	1015 Test start									
2/5/2008	1032	0.3	0	0	0.10		72.8	0.18	9.2	1019
2/5/2008	1129	0	0	0	2.6		77.7		10.9	1019
2/5/2008	1338	0	0	0	3.9		82.5	0.20	12.5	1019

Aerojet GEDIT - Injection Test Input

Phase II Piezometer Monitoring Data

Well ID P6

Depth 18

Date	Time	Well or Injection Gas Sample						Well	Ambient Air	
		O ₂ (%)	CO ₂ (%)	Propane (%)	H ₂ (%)	He (ppm)	RH (%)	Pressure (in wc)	Temperature (C°)	Barometric pressure (mbar)
2/5/2008	1506	0	0	0	3.7		79.5		14.7	1019
2/5/2008	1550	0	0	0	3.5		63.2		18.6	1018

Tracer Test #6 (30 cfm total; 10 cfm to each INJ1, 2, and 3; ~8% H2)										
2/7/2008	1500 Test start									
2/7/2008	1531	0.0	0	0	0.046		57.6		22.2	1016
2/7/2008	1619	0.0	0	0	1.4		56.1		21.1	1016
2/8/2008	1008	0.0	0	0	8.8		64.5		10.8	1017

Tracer Test #7 (60 cfm total; 20 cfm to each INJ1, 2, and 3, ~5% H2)										
1/17/2008	900 Test start									
1/17/2008	1028	10.7	0	0	0.99		76	0.04	8.2	1015
1/17/2008	1141	5.0	0	0	3.6		77.7		9.8	1015
1/17/2008	1356	1.7	0.16	0	5.2		70.6		13.2	1013
1/17/2008	1517	1.2	0.16	0	5.7		60.9		18.3	1012

Tracer Test #8 (90 cfm total; 30 cfm each to INJ1, 2, and 3; ~4.5% H2)										
2/6/2008	1000 Test start									
2/6/2008	1033	0.0	0	0	0.52		79.1	0.20	11.2	1020
2/6/2008	1146	0.0	0	0	3.0		79.1		12.8	1020

Aerojet GEDIT - Injection Test Input

Phase II Piezometer Monitoring Data

Well ID P6

Depth 18

Date	Time	Well or Injection Gas Sample						Well	Ambient Air	
		O ₂ (%)	CO ₂ (%)	Propane (%)	H ₂ (%)	He (ppm)	RH (%)	Pressure (in wc)	Temperature (C°)	Barometric pressure (mbar)
2/6/2008	1243	0.0	0	0	3.8		76.6		14.2	1019
2/6/2008	1439	0.0	0	0	4.7		80.2	0.20	16.0	1017
2/6/2008	1535	0.0	0	0	4.6		68.8		17.4	1017

Optimization Test #1 (90 cfm to INJ2 for 4 hours then shut down; ~88% N2, 10% H2, 1% CO2 & LPG)										
2/20/2008	1135	6	0.00	0	0.046		73.8		15.1	1010
2/20/2008	1206 Test start									
2/20/2008	1543	0.0	0.62	1.02	11		53.7		23.7	1007
2/20/2008	1606 Test End									
2/20/2008	1630	0.0	0.54	1.02	11		52.8		22.8	1008
2/21/2008	915	0.0	0.38	1.04	9.9		78.4		10.8	1005
2/22/2008	1041	2.6	0.32	0.72	4.8		83.8		9.7	1003

Optimization Test #2 (30 cfm to INJ2 for 12 hours then shut down; ~88% N2, 10% H2, 1% CO2 & LPG)										
2/25/2008	1845 Test Start									
2/26/2008	653 Test End									
2/26/2008	707	0.0	2.18	0.62	7.1		90.7		3.3	1017
2/27/2008	1535	0.6	1.14	0.42	4.3		39.4		35.6	1009
2/28/2008	1100	2.3	0.92	0.4	2.3		75.8		16.3	1007

Aerojet GEDIT - Injection Test Input

Phase II Piezometer Monitoring Data

Well ID P6

Depth 18

Date	Time	Well or Injection Gas Sample						Well	Ambient Air
		O ₂ (%)	CO ₂ (%)	Propane (%)	H ₂ (%)	He (ppm)	RH (%)	Pressure (in wc)	Temperature (C°)
Optimization Test #3A (1 cfm to INJ2; ~88% N2, 10% H2, 1% CO2 & LPG)									
2/29/2008	1319								
2/29/2008	1435	4.4	0.66	0.36	0.72		55.7	24.1	1009
3/3/2008	1049	1.2	0.92	0.58	5		65.3	15.4	1019
3/3/2008	1130								
Optimization Test #3B (1 cfm to INJ1, INJ2 & INJ3; ~88% N2, 10% H2, 1% CO2 & LPG)									
3/3/2008	1130								
3/4/2008	930	2.3	1.02	0.68	3.7		69.9	12.7	1013
3/7/2008	1107	2.8	0.62	0.68	4.1		62.8	18.4	1018
3/7/2008	1306								
Optimization Test #3C (90 cfm to INJ1, INJ2 & INJ3 for 15 minutes then shut down; ~79% N2, 10% H2 & LPG, 1% CO2)									
3/7/2008	1306								
3/7/2008	1321								
3/7/2008	1338	4.4	0.6	0.52	3.4		57	22.2	1016
3/10/2008	1055	7.9	0.54	0.64	0.22		71	16.6	1016
Optimization Test #4 (2, 45-minutes pulses; daily 15-minutes pulses w/30cfh constant flow)									
3/10/2008	1324	8.5	0.64	0.86	0.59		63.5	21.7	1016

Aerojet GEDIT - Injection Test Input

Phase II Piezometer Monitoring Data

Well ID P6

Depth 18

Date	Time	Well or Injection Gas Sample						Well	Ambient Air
		O ₂ (%)	CO ₂ (%)	Propane (%)	H ₂ (%)	He (ppm)	RH (%)	Pressure (in wc)	Temperature (C°)
Optimization Test #5 (20 cfh to INJ2 for 125 minutes while maintaing 30 cfh the rest of the time; ~80% N2, 10% H2 & LPG)									
Optimization Test #6 (50 cfh to P4-18 & P4-28; ~80% N2, 10% H2 & LPG)									
3/20/2008	1330	Start Test							
3/21/2008	1014		0.0	0.26	2.0	5.0	77.2	12.5	1020
3/24/2008	1008		0.0	0.12	2.0	3.9	69.5	15.9	1012
3/26/2008	950		0.0	0.06	2.0	4.6	82.6	11.0	1017
3/28/2008	946		0.0	0.04	2.0	2.6	77.7	10.4	1009
3/31/2008	948		0.0	0.06	15.0	10.0	80.9	9.6	1013
4/2/2008	1045		0.0	0.06	14.5	11.0	78.6	14.5	1008
Optimization Test #7 (20 cfh to P4-18, --28, -38 (60 cfh total); ~80% N2, 10% H2 & LPG)									
4/2/2008	1233	Start Test							
4/4/2008	929		0.0	0.02	11.5	15.0	80.4	12.3	1013
4/7/2008	1356		1.1	0.00	5.5	15.0	68.5	18.8	1012
Optimization Test #7B (30 cfh to P4-18, & P4-28 (60 cfh total); ~80% N2, 10% H2 & LPG)									
4/7/2008	1458	Start Test							
4/9/2008	1046		2.0	0.00	2.0	22.0	80.5	14.4	1009

Aerojet GEDIT - Injection Test Input

Phase II Piezometer Monitoring Data

Well ID P6

Depth 18

Date	Time	Well or Injection Gas Sample						Well	Ambient Air	
		O ₂ (%)	CO ₂ (%)	Propane (%)	H ₂ (%)	He (ppm)	RH (%)	Pressure (in wc)	Temperature (C°)	Barometric pressure (mbar)
Optimization Test #7C (50 cfh to P4-18, & P4-28 (100 cfh total); ~79% N2, 10% H2 & LPG, 1% CO2)										
4/10/2009	1121	Start Test								
4/11/2008	1224	0.2	0.00	0.2	14.0		65.2	21.6	1013	
4/14/2008	1008	2.9	0.00	9.0	1.8		81.8	15.7	1007	
4/16/2008	1019	0.0	0.84	9.0	9.5		76.8	15.0	1011	
4/22/2008	1041	0.0	0.04	12.0	10.0		84.6	19.5	1009	
4/23/2008	936	0.1	0.00	9.0	3.4		83.1	12.7	1010	
4/25/2008	947	1.4	0.00	8.5	0.10		73.7	18.8	1015	
4/29/2008	1059	0.0	0.08	9.0	7.3		57.7	25.5	1007	
5/5/2008	1304	0.0	0.96	9.0	10.0		53.6	33.0	1001	
5/13/2008	921	0.0	0.92	9.5	2.2		42.9	32.9	1007	
5/20/2008	923	0.0	0.58	7.5	10.0		72.9	23.6	1004	
5/23/2008	1508	0.0	0.72	7.0	22		56.4	31.6	990	
5/27/2008	853	0.0	1.94	9.5	8.8		76.6	16.4	1007	
6/4/2008	856	0.0	0.18	9.5	6.3		59.3	24.1	1002	
6/12/2008	1138	0.0	0.66	9.5	3.9		39.0	39.4	1003	
6/20/2008	1009	0.0	0.72	8.5	6.600		49.5	36.5	1006	
6/25/2008	1035	0.0	1.02	9.0	13.0		56.7	31.2	1005	
7/2/2008	1135	0.0	1.36	9.5	13.0		54.0	32.6	1004	
7/7/2008	1125	0	0.16	9	7.1		48.6	35.5	998	

Aerojet GEDIT - Injection Test Input

Phase II Piezometer Monitoring Data

Well ID P6

Depth 18

Date	Time	Well or Injection Gas Sample						Well	Ambient Air
		O ₂ (%)	CO ₂ (%)	Propane (%)	H ₂ (%)	He (ppm)	RH (%)	Pressure (in wc)	Temperature (C°)
7/18/2008	1052	0	0.08	9.5	10		76.6	24.9	
7/24/2008	1050	0.0	0.46	9.0	12.000		57.2	27.9	1005
7/31/2008	1048	0.0	1.12	9.5	11.000		61.3	26.7	1003
8/7/2008	923	0.0	0.16	9.0	9.4		70.5	24.2	1004
8/12/2008	1025	0.0	0.00	9.5	10.0		53.2	28.8	1002
Optimization Test #8 (100 cfh of 100% Propane to P4-18, & P4-28 (50 cfh to each point)									
9/8/2008	0905 Test Start								
9/8/2008	1029	10.5	0.6	2.5	0.002				999
9/15/2008	913	11.0	0.66	2.5	0.005		57.8	24.7	1007
9/29/2008	932	12.7	0.96	2.5	0.005		57.8	22.1	1006
10/13/2008	1155	17.6	0.98	3.0	0.005		35.8	30.7	1017
10/20/2008	1122	16.0	1.36	2.0	0.005		50.8	25.8	1013
11/5/2008	1358	15.7	1.98	1.38	0.005		78.3	18.8	1016
11/17/2008	1111	13.4	2.36	2.0	0.005		49.1	28.7	1014
12/1/2008	1112	12.7	3.02	2.0	0.002		57.2	22.3	1014

Aerojet GEDIT - Injection Test Input

Phase II Piezometer Monitoring Data

Well ID P6

Depth 28

Date	Time	Well or Injection Gas Sample						Well	Ambient Air		
		O ₂ (%)	CO ₂ (%)	Propane (%)	H ₂ (%)	He (ppm)	RH (%)	Pressure (in wc)	Temperature (C°)	Barometric pressure (mbar)	
12/12/2007	1156	20.0	0.02	0	0.002	60,000	87.7	0.02	11.6	1020	
12/12/2007	1537							0.22			
12/13/2007	903	9.8	0	0	7.8		77.2		7.1	1016	
12/13/2007	959	11.3	0	0	8.3		68.8		12.2	1016	
12/13/2007	1200	Discovered leak in O2 - all O2 data for 12/13/07 before 1200 invalid									
12/13/2007	1343	0	0	0	8.6		81.1		16.4	1013	
12/13/2007	1507	0	0.48	0.52	0.46		87.4		13.9	1013	
12/13/2007	1539	0	0.56	0.52	0.22		85.1		12.9	1013	
12/14/2007	847	0	0.06	0	0.46		63.3	0.0	7.3	1016	
12/21/2007	1211	15.3	0.12	0.02	0.46		91.7	0.04	10.3	1012	
12/26/2007	1236	17.6	0.12	0	0.22		75.2	0.03	13.8	1016	
12/27/2007	1025	0.1	0.04	0	9.5		80.2	0.04	6.1	1018	
12/27/2007	1326	0.1	0	0	9.2		82.9		8.9	1016	
12/27/2007	1447	0.1	0	0	9.5		86.1		8.5	1017	
12/27/2007	1609	0.1	0	0	9.9		87.7	0.04	7.4	1017	
1/2/2008	1042	0.1	0	0	0.022		66.3	0.02	16.1	1012	

Tracer Test #1 (10 cfm to INJ2, ~7% H2)										
1/21/2008	1046 Test start									
1/21/2008	1212	1.3	0	0	2.7		82.1	0.05	10.1	1007

Aerojet GEDIT - Injection Test Input

Phase II Piezometer Monitoring Data

Well ID P6

Depth 28

Date	Time	Well or Injection Gas Sample						Well	Ambient Air	
		O ₂ (%)	CO ₂ (%)	Propane (%)	H ₂ (%)	He (ppm)	RH (%)	Pressure (in wc)	Temperature (C°)	Barometric pressure (mbar)
1/21/2008	1313	1.2	0	0	4.6		81.9		9.6	1006
1/21/2008	1509	1.2	0	0	5.7		82.1		11.1	1006
1/22/2008	1002	1.1	0	0	7.0		84.0	0.09	6.8	1011
1/22/2008	1405	0.8	0	0	7.0		83.7		8.8	1009
1/23/2008	1026	1.0	0	0	6.9		86.5	0.08	8.1	1008
1/23/2008	1119*	0.6								

Tracer Test #2 (20 cfm to INJ2, ~8% H2)										
1/18/2008	1120 Test start									
1/18/2008	1202	1.2	0	0	3.9		73.6		13.0	1015
1/18/2008	1305	0.8	0	0	6.2		67.0		14.8	1014
1/18/2008	1354	1.3	0	0	6.7		67.8		15.7	1014
1/18/2008	1533	0.9	0	0	7.2		48.1	0.03	23.2	1014
1/19/2008	1012	0.8	0	0	7.3		65.4	0.02	9.4	1019
1/19/2008	1146*	0.6	0	0	6.2		71.5		12.7	1018

Tracer Test #3 (30 cfm to INJ2, ~4% H2)										
1/30/2008	1036 Test start									
1/30/2008	1112	0.0	0	0	3.3		88.6	0.10	9.8	1020
1/30/2008	1222	0.0	0	0	4.2		81.1		11.2	1019

Aerojet GEDIT - Injection Test Input

Phase II Piezometer Monitoring Data

Well ID P6

Depth 28

Date	Time	Well or Injection Gas Sample						Well	Ambient Air	
		O ₂ (%)	CO ₂ (%)	Propane (%)	H ₂ (%)	He (ppm)	RH (%)	Pressure (in wc)	Temperature (C°)	Barometric pressure (mbar)
1/30/2008	1422	0.0	0	0	4.7		79.1	0.11	13.3	1018
1/31/2008	951	0.0	0	0	4.1		87.8	0.17	8.7	1019
1/31/2008	1131	0	0	0	3.8		84.6		9.5	1018
1/31/2008	1347	0	0	0	3.8		81.7	0.12	8.8	1016
1/31/2008	1435									
1/31/2008	1515	0	0	0	3.9		85.5	0.04	8.2	1014

Tracer Test #4 (60 cfm to INJ2, ~7% H2)										
1/28/2008	1236 Test start									
1/28/2008	1303	0.2	0	0	5.1		91.6		10.5	1010
1/28/2008	1414	0.0	0	0	6.0		79.9	0.20	13.2	1011
1/28/2008	1555	0.0	0	0	6.5		83.1	0.21	12.2	1011
1/29/2008	800	0.0	0	0	7.3		87.3	0.11	4.8	1016
1/29/2008	Final O2*	0.0								

Tracer Test #5 (90 cfm to INJ2, ~3% H2)										
2/5/2008	1015 Test start									
2/5/2008	1033	0	0	0	3.1		68.2	0.23	9.3	1019
2/5/2008	1131	0	0	0	3.4		72.0		11.0	1019
2/5/2008	1341	0	0	0	4.0		75.0	0.26	12.6	1019

Aerojet GEDIT - Injection Test Input

Phase II Piezometer Monitoring Data

Well ID P6

Depth 28

Date	Time	Well or Injection Gas Sample						Well	Ambient Air	
		O ₂ (%)	CO ₂ (%)	Propane (%)	H ₂ (%)	He (ppm)	RH (%)	Pressure (in wc)	Temperature (C°)	Barometric pressure (mbar)
2/5/2008	1507	0	0	0	3.7		77.4		15.2	1019
2/5/2008	1551	0	0	0	3.5		57.3		18.9	1018

Tracer Test #6 (30 cfm total; 10 cfm to each INJ1, 2, and 3; ~8% H2)										
2/7/2008	1500 Test start									
2/7/2008	1532	0.0	0	0	0.046		48.5		22.1	1016
2/7/2008	1621	0.0	0	0	2.3		50.7		20.9	1016
2/8/2008	1009	0.0	0	0	2.6		63.1		20.7	1017

Tracer Test #7 (60 cfm total; 20 cfm to each INJ1, 2, and 3, ~5% H2)										
1/17/2008	900 Test start									
1/17/2008	1030	7.8	0	0	2.1		72.8	0.02	8.3	1015
1/17/2008	1143	5.3	0	0	3.6		77.0		9.9	1015
1/17/2008	1358	3.9	0.08	0	4.7		68.5		13.6	1013
1/17/2008	1519	2.7	0.08	0	5.1		57.3		18.9	1012

Tracer Test #8 (90 cfm total; 30 cfm each to INJ1, 2, and 3; ~4.5% H2)										
2/6/2008	1000 Test start									
2/6/2008	1035	0.0	0	0	2.8		77.2	0.19	11.1	1020
2/6/2008	1147	0.0	0	0	3.8		74.6		12.8	1020

Aerojet GEDIT - Injection Test Input

Phase II Piezometer Monitoring Data

Well ID P6

Depth 28

Date	Time	Well or Injection Gas Sample						Well	Ambient Air	
		O ₂ (%)	CO ₂ (%)	Propane (%)	H ₂ (%)	He (ppm)	RH (%)	Pressure (in wc)	Temperature (C°)	Barometric pressure (mbar)
2/6/2008	1244	0.0	0	0	4.0		71.2		14.3	1019
2/6/2008	1440	0.0	0	0	4.7		70.3	0.20	16.0	1017
2/6/2008	1536	0.0	0	0	4.6		62.8		17.6	1017

Optimization Test #1 (90 cfm to INJ2 for 4 hours then shut down; ~88% N2, 10% H2, 1% CO2 & LPG)										
2/20/2008	1136	6.9	0.00	0	0.046		74.6		15.3	1010
2/20/2008	1206 Test start									
2/20/2008	1544	0.0	0.80	1.04	10		52.9		23.9	1007
2/20/2008	1606 Test End									
2/20/2008	1631	0.0	0.68	1.06	9.6		52.7		22.7	1008
2/21/2008	917	1.5	0.28	0.88	9.1		76.2		10.8	1005
2/22/2008	1042	7	0.14	0.34	3.7		83		9.7	1003

Optimization Test #2 (30 cfm to INJ2 for 12 hours then shut down; ~88% N2, 10% H2, 1% CO2 & LPG)										
2/25/2008	1845 Test Start									
2/26/2008	653 Test End									
2/26/2008	708	0.0	2	0.48	7.3		89.5		3.3	1017
2/27/2008	1537	6.3	0.6	0.28	3.2		36.3		36.4	1009
2/28/2008	1101	8.6	0.44	0.2	1.8		75.1		16.3	1007

Aerojet GEDIT - Injection Test Input

Phase II Piezometer Monitoring Data

Well ID P6

Depth 28

Date	Time	Well or Injection Gas Sample						Well	Ambient Air
		O ₂ (%)	CO ₂ (%)	Propane (%)	H ₂ (%)	He (ppm)	RH (%)	Pressure (in wc)	Temperature (C°)
Optimization Test #3A (1 cfm to INJ2; ~88% N2, 10% H2, 1% CO2 & LPG)									
2/29/2008	1319 Test Start								
2/29/2008	1436	8.6	0.30	0.22	0.98		64.6	24.4	1009
3/3/2008	1051	9	0.32	0.28	2.3		66.8	15.6	1019
3/3/2008	1130 Test End								
Optimization Test #3B (1 cfm to INJ1, INJ2 & INJ3; ~88% N2, 10% H2, 1% CO2 & LPG)									
3/3/2008	1130 Test Start								
3/4/2008	931	11.6	0.36	0.16	1.3		73.4	12.8	1013
3/7/2008	1108	11.7	0.18	0.14	1.1		63.8	18.4	1018
3/7/2008	1306 Test End								
Optimization Test #3C (90 cfm to INJ1, INJ2 & INJ3 for 15 minutes then shut down; ~79% N2, 10% H2 & LPG, 1% CO2)									
3/7/2008	1306 Start Pulse								
3/7/2008	1321 End Pulse								
3/7/2008	1339	9.4	0.2	1.02	2.1		60	22.2	1016
3/10/2008	1056	11.7	0.1	0.18	0.1		69.1	16.6	1016
Optimization Test #4 (2, 45-minutes pulses; daily 15-minutes pulses w/30cfh constant flow)									
3/10/2008	1326	1.4	0.72	6.5	7.3				

Aerojet GEDIT - Injection Test Input

Phase II Piezometer Monitoring Data

Well ID P6

Depth 28

Date	Time	Well or Injection Gas Sample						Well	Ambient Air
		O ₂ (%)	CO ₂ (%)	Propane (%)	H ₂ (%)	He (ppm)	RH (%)	Pressure (in wc)	Temperature (C°)
Optimization Test #5 (20 cfm to INJ2 for 125 minutes while maintaing 30 cfh the rest of the time; ~80% N2, 10% H2 & LPG)									
Optimization Test #6 (50 cfh to P4-18 & P4-28; ~80% N2, 10% H2 & LPG)									
3/20/2008	1330 Start Test								
3/21/2008	1015	7.5	0.10	2.5	1.4		78.7	12.5	1020
3/24/2008	1009	5.2	0.06	2.5	1.1		68.7	15.8	1012
3/26/2008	950	4.0	0.02	2.5	1.3		79.4	11.0	1017
3/28/2008	947	3.8	0.02	2.0	0.98		76.2	10.5	1009
3/31/2008	949	0.9	0.00	12.0	6.8		83.5	9.7	1013
4/2/2008	1046	0.4	0.02	13.0	6.1		77.3	14.7	1008
Optimization Test #7 (20 cfh to P4-18, --28, -38 (60 cfh total); ~80% N2, 10% H2 & LPG)									
4/2/2008	1233 Start Test								
4/4/2008	930	0.6	0.04	12.0	5.5		77.2	12.5	1013
4/7/2008	1357	4.0	0.10	9.0	3.8		68.9	18.8	1012
Optimization Test #7B (30 cfh to P4-18, & P4-28 (60 cfh total); ~80% N2, 10% H2 & LPG)									
4/7/2008	1458 Start Test								
4/9/2008	1049	6.2	0.04	7.0	1.6		79.0	14.5	1009

Aerojet GEDIT - Injection Test Input

Phase II Piezometer Monitoring Data

Well ID P6

Depth 28

Date	Time	Well or Injection Gas Sample						Well	Ambient Air	
		O ₂ (%)	CO ₂ (%)	Propane (%)	H ₂ (%)	He (ppm)	RH (%)	Pressure (in wc)	Temperature (C°)	Barometric pressure (mbar)
Optimization Test #7C (50 cfh to P4-18, & P4-28 (100 cfh total); ~79% N2, 10% H2 & LPG, 1% CO2)										
4/10/2009	1121	Start Test								
4/11/2008	1226	8.2	0.06	4.5	1.4		65.4	21.6	1013	
4/14/2008	1009	2.3	0.02	10.0	1.4		82.5	15.8	1007	
4/16/2008	1020	1.4	0.02	9.5	4.1		69.1	15.1	1011	
4/22/2008	1042	4.1	0.06	4.5	1.7		84.2	19.6	1009	
4/23/2008	937	2.2	0.00	6.5	0.60		83.2	12.6	1010	
4/25/2008	950	0.0	0.00	9.5	0.10		73.0	18.9	1015	
4/29/2008	1100	0.5	0.00	8.5	2.3		58.8	25.4	1007	
5/5/2008	1305	2.0	0.00	7.0	2.1		53.1	33.1	1001	
5/13/2008	924	0.0	0.00	10.0	1.3		41.4	33.3	1007	
5/20/2008	925	2.5	0.10	7.5	0.69		74.9	23.8	1004	
5/23/2008	1509	1.5	0.00	8.5	1.2		49.6	31.2	990	
5/27/2008	855	1.4	0.16	8.0	2.9		75.9	16.4	1007	
6/4/2008	858	0.0	0.04	9.0	2.4		58.8	24.3	1002	
6/12/2008	1139	0.4	0.02	9.0	4.1		32.7	39.5	1003	
6/20/2008	1011	0.0	0.06	8.5	2.200		39.0	37.4	1006	
6/25/2008	1036	0.1	0.16	8.0	2.0		50.3	31.0	1005	
7/2/2008	1136	0.0	0.26	8.0	2.2		51.0	32.3	1004	
7/7/2008	1126	0	0.12	8.5	2		43.7	35.3	998	

Aerojet GEDIT - Injection Test Input

Phase II Piezometer Monitoring Data

Well ID P6

Depth 28

Date	Time	Well or Injection Gas Sample						Well	Ambient Air	
		O ₂ (%)	CO ₂ (%)	Propane (%)	H ₂ (%)	He (ppm)	RH (%)	Pressure (in wc)	Temperature (C°)	Barometric pressure (mbar)
7/18/2008	1053	0	0.38	8.5	2.2		80.8		25	
7/24/2008	1051	0.0	0.46	8.5	2.100		59.1		28.0	1005
7/31/2008	1149	0.0	0.42	8.5	2.500		59.6		26.7	1003
8/7/2008	924	0.0	0.40	8.5	2.3		70.1		25.1	1004
8/12/2008	1027	0.0	0.44	8.5	2.0		60.0		28.7	1002
Optimization Test #8 (100 cfh of 100% Propane to P4-18, & P4-28 (50 cfh to each point)										
9/8/2008	0905 Test Start									
9/8/2008	1030	4.4	0.2	7	0.005					999
9/15/2008	915	4.2	0.2	30	0.005		58.2		24.9	1007
9/29/2008	933	4.6	0.10	30	0.005		59.3		22.2	1006
10/13/2008	1156	8.0	0.10	30	0.005		34.3		31.2	1017
10/20/2008	1123	5.8	0.12	30	0.005		45.9		26.1	1013
11/5/2008	1359	5.0	0.16	30	0.005		78.4		18.8	1016
11/17/2008	1112	4.2	0.18	30	0.005		49.7		28.6	1014
12/1/2008	1113	3.7	0.22	30	0.002		56.2		22.7	1014

Aerojet GEDIT - Injection Test Input

Phase II Piezometer Monitoring Data

Well ID P6

Depth 38

Date	Time	Well or Injection Gas Sample						Well	Ambient Air		
		O ₂ (%)	CO ₂ (%)	Propane (%)	H ₂ (%)	He (ppm)	RH (%)	Pressure (in wc)	Temperature (C°)	Barometric pressure (mbar)	
12/12/2007	1158	19.4	0.48	0	0.002	60,000	87.0	0.00	11.8	1020	
12/12/2007	1536							0.24			
12/13/2007	906	10.8	0.08	0	0.46		79.4		7.2	1016	
12/13/2007	1000	11.7	0	0	5.7		70.6		12.7	1016	
12/13/2007	1200	Discovered leak in O2 - all O2 data for 12/13/07 before 1200 invalid									
12/13/2007	1344	0	0.12	0	8.6		76.1		16.2	1013	
12/13/2007	1509	0	0.10	0.16	6.6		86.4		13.8	1013	
12/13/2007	1540	0	0.08	0.38	2.6		84.3		13.1	1013	
12/14/2007	849	0	0.02	0.16	0.87		65.9	0.06	7.5	1017	
12/21/2007	1214	8.1	0.52	0.08	0.59		90.7	0.02	10.8	1012	
12/26/2007	1238	13.3	0.56	0.04	0.22		76.1	0.03	13.3	1016	
12/27/2007	1027	10.5	0.58	0.04	2.5		80.1	0.04	6.1	1018	
12/27/2007	1329	9.7	0.46	0.04	3.2		84		9	1016	
12/27/2007	1448	9.3	0.46	0.04	3.7		87.7		8.4	1017	
12/27/2007	1611	8.9	0.48	0.04	4.1		88.1	0.02	7.3	1017	
1/2/2008	1045	1.1	0.42	0	0.22		62.2	0.02	16.5	1012	

Tracer Test #1 (10 cfm to INJ2, ~7% H2)										
1/21/2008	1046 Test start									
1/21/2008	1214	2.1	0.26	0	0.74		82.4	0.06	10.3	1007

Aerojet GEDIT - Injection Test Input

Phase II Piezometer Monitoring Data

Well ID P6

Depth 38

Date	Time	Well or Injection Gas Sample						Well	Ambient Air	
		O ₂ (%)	CO ₂ (%)	Propane (%)	H ₂ (%)	He (ppm)	RH (%)	Pressure (in wc)	Temperature (C°)	Barometric pressure (mbar)
1/21/2008	1314	2.1	0.30	0	0.79		82.9		9.7	1006
1/21/2008	1510	2.1	0.28	0	0.83		81.3		11.1	1006
1/22/2008	1003	1.9	0.28	0	4.0		82.1	0.07	6.7	1011
1/22/2008	1406	1.7	0.24	0	4.4		83.8		8.7	1009
1/23/2008	1027	1.7	0.28	0	5.2		85.8	0.06	8.1	1008
1/23/2008	1120*	1.1								

Tracer Test #2 (20 cfm to INJ2, ~8% H2)										
1/18/2008	1120 Test start									
1/18/2008	1205	1.9	0.34	0	0.85		71.5		12.9	1015
1/18/2008	1307	1.7	0.30	0	0.81		65.2		14.8	1014
1/18/2008	1356	2.1	0.30	0	0.90		67.1		15.2	1014
1/18/2008	1534	1.9	0.28	0	1.6		48.2	0.04	23.5	1014
1/19/2008	1014	1.4	0.34	0	9.2		62.3	0.01	9.4	1019
1/19/2008	1148*	0.8	0.32	0	9.2		71.8		12.7	1018

Tracer Test #3 (30 cfm to INJ2, ~4% H2)										
1/30/2008	1036 Test start									
1/30/2008	1114	0.0	0.04	0	1.8		90.5	0.10	9.7	1020
1/30/2008	1224	0.0	0.02	0	1.6		81.8		11.2	1019

Aerojet GEDIT - Injection Test Input

Phase II Piezometer Monitoring Data

Well ID P6

Depth 38

Date	Time	Well or Injection Gas Sample						Well	Ambient Air	
		O ₂ (%)	CO ₂ (%)	Propane (%)	H ₂ (%)	He (ppm)	RH (%)	Pressure (in wc)	Temperature (C°)	Barometric pressure (mbar)
1/30/2008	1423	0.0	0.02	0	2.6		76.2	0.10	13.5	1018
1/31/2008	952	0.0	0	0	4.3		86.0	0.11	8.7	1019
1/31/2008	1132	0	0	0	3.9		83.3		9.5	1018
1/31/2008	1348	0	0	0	3.8		79.4	0.11	8.8	1016
1/31/2008	1435									
1/31/2008	1516	0	0.02	0	3.8		83.6	0.05	8.2	1014

Tracer Test #4 (60 cfm to INJ2, ~7% H2)										
1/28/2008	1236 Test start									
1/28/2008	1304	4.1	0.28	0	0.22		90.8		10.5	1010
1/28/2008	1415	4.4	0.26	0	1.6		81.1	0.26	12.9	1011
1/28/2008	1556	1.0	0.16	0	4.8		81.5	0.18	12.3	1011
1/29/2008	801	0.0	0.06	0	7.4		85.4	0.07	7.8	1016
1/29/2008	Final O2*									

Tracer Test #5 (90 cfm to INJ2, ~3% H2)										
2/5/2008	1015 Test start									
2/5/2008	1035	3.3	0	0	0.10		68.0	0.20	9.4	1019
2/5/2008	1132	1.8	0	0	1.2		70.0		11.0	1019
2/5/2008	1342	0.1	0	0	3.7		75.5	0.22	12.6	1019

Aerojet GEDIT - Injection Test Input

Phase II Piezometer Monitoring Data

Well ID P6

Depth 38

Date	Time	Well or Injection Gas Sample						Well	Ambient Air	
		O ₂ (%)	CO ₂ (%)	Propane (%)	H ₂ (%)	He (ppm)	RH (%)	Pressure (in wc)	Temperature (C°)	Barometric pressure (mbar)
2/5/2008	1508	0	0	0	3.6		75.4		16.3	1019
2/5/2008	1552	0	0	0	3.5		59.5		19.0	1018

Tracer Test #6 (30 cfm total; 10 cfm to each INJ1, 2, and 3; ~8% H2)										
2/7/2008	1500 Test start									
2/7/2008	1533	0.0	0.04	0	0.046		51.2		22.0	1016
2/7/2008	1621	0.0	0.04	0	0.46		51.7		20.9	1016
2/8/2008	1015	0.0	0.02	0	6.5		66.8		10.1	1017
2/8/2008	1059	0.0	0	0	6.3		76.2		11.1	1017

Tracer Test #7 (60 cfm total; 20 cfm to each INJ1, 2, and 3, ~5% H2)										
1/17/2008	900 Test start									
1/17/2008	1031	14.2	0.30	0	0.22		72.4	0.02	8.4	1015
1/17/2008	1144	12.6	0.28	0	0.22		75.1		9.9	1015
1/17/2008	1359	7.7	0.46	0	3.0		68.2		13.7	1013
1/17/2008	1521	4.5	0.48	0	4.2		55.7		19.2	1012

Tracer Test #8 (90 cfm total; 30 cfm each to INJ1, 2, and 3; ~4.5% H2)										
2/6/2008	1000 Test start									
2/6/2008	1037	0.0	0	0	0.86		77.4	0.18	11.1	1020

Aerojet GEDIT - Injection Test Input

Phase II Piezometer Monitoring Data

Well ID P6

Depth 38

Date	Time	Well or Injection Gas Sample						Well	Ambient Air	
		O ₂ (%)	CO ₂ (%)	Propane (%)	H ₂ (%)	He (ppm)	RH (%)	Pressure (in wc)	Temperature (C°)	Barometric pressure (mbar)
2/6/2008	1148	0.0	0	0	0.77		74.3		12.8	1020
2/6/2008	1246	0.0	0	0	1.8		72.3		14.4	1019
2/6/2008	1442	0.0	0	0	3.8		74.4	0.16	16.2	1017
2/6/2008	1538	0.0	0	0	3.9		62.2		17.5	1017
2/6/2008	1627	0.0	0.02	0	4.0		62.6		17.9	1017

Optimization Test #1 (90 cfm to INJ2 for 4 hours then shut down; ~88% N2, 10% H2, 1% CO2 & LPG)										
2/20/2008	1137	6.5	0.12	0	0.046		73.8		15.3	1010
2/20/2008	1206 Test start									
2/20/2008	1545	0.5	0.04	0.94	11		52.3		24.4	1008
2/20/2008	1606 Test End									
2/20/2008	1632	0.4	0.02	0.96	11		51.8		22.7	1008
2/21/2008	918	3.0	0.08	0.44	6		74.3		10.9	1004
2/22/2008	1044	4.2	0.10	0.26	3.2		82.7		9.9	1003

Optimization Test #2 (30 cfm to INJ2 for 12 hours then shut down; ~88% N2, 10% H2, 1% CO2 & LPG)										
2/25/2008	1845 Test Start									
2/26/2008	653 Test End									
2/26/2008	710	1.0	0.32	0.7	6.2		88.7		3.4	1017
2/27/2008	1538	4.7	0.16	0.28	2.5		36.9		37.1	1009
2/28/2008	1102	5.5	0.12	0.24	1.6		74.9		16.4	1007

Aerojet GEDIT - Injection Test Input

Phase II Piezometer Monitoring Data

Well ID P6

Depth 38

Date	Time	Well or Injection Gas Sample						Well	Ambient Air
		O ₂ (%)	CO ₂ (%)	Propane (%)	H ₂ (%)	He (ppm)	RH (%)	Pressure (in wc)	Temperature (C°)
Optimization Test #3A (1 cfm to INJ2; ~88% N2, 10% H2, 1% CO2 & LPG)									
2/29/2008	1319 Test Start								
2/29/2008	1437	6.4	0.06	0.24	0.82		71.8	24.7	1009
3/3/2008	1052	8.1	0.14	0.14	0.046		63.8	15.6	1019
3/3/2008	1130 Test End								
Optimization Test #3B (1 cfm to INJ1, INJ2 & INJ3; ~88% N2, 10% H2, 1% CO2 & LPG)									
3/3/2008	1130 Test Start								
3/4/2008	933	8.7	0.22	0.12	0.022		71.9	12.9	1013
3/7/2008	1109	10.1	0.12	0.1	0.022		65.9	18.5	1018
3/7/2008	1306 Test End								
Optimization Test #3C (90 cfm to INJ1, INJ2 & INJ3 for 15 minutes then shut down; ~79% N2, 10% H2 & LPG, 1% CO2)									
3/7/2008	1306 Start Pulse								
3/7/2008	1321 End Pulse								
3/7/2008	1341	10	0.1	0.1	0.022		64.2	22.3	1016
3/10/2008	1057	10.8	0.22	0.08	0.022		68.9	16.6	1016
Optimization Test #4 (2, 45-minutes pulses; daily 15-minutes pulses w/30cfh constant flow)									

Aerojet GEDIT - Injection Test Input

Phase II Piezometer Monitoring Data

Well ID P6

Depth 38

Date	Time	Well or Injection Gas Sample						Well	Ambient Air
		O ₂ (%)	CO ₂ (%)	Propane (%)	H ₂ (%)	He (ppm)	RH (%)	Pressure (in wc)	Temperature (C°)
Optimization Test #5 (20 cfm to INJ2 for 125 minutes while maintaing 30 cfh the rest of the time; ~80% N2, 10% H2 & LPG)									
Optimization Test #6 (50 cfh to P4-18 & P4-28; ~80% N2, 10% H2 & LPG)									
3/20/2008	1330	Start Test							
3/21/2008	1017	9.4	0.24	1.0	0.022		81.1	12.6	1020
3/24/2008	1010	8.7	0.34	1.78	0.022		69.5	15.8	1012
3/26/2008	952	8.2	0.34	2.0	0.022		80.3	11.0	1017
3/28/2008	948	8.1	0.36	2.0	0.022		74.0	10.5	1009
3/31/2008	950	6.5	0.30	2.5	1.2		84.7	9.8	1013
4/2/2008	1047	6.2	0.30	3.5	1.3		76.5	14.9	1008
Optimization Test #7 (20 cfh to P4-18, --28, -38 (60 cfh total); ~80% N2, 10% H2 & LPG)									
4/2/2008	1233	Start Test							
4/4/2008	932	4.1	0.32	8.0	1.2		80.2	12.6	1013
4/7/2008	1358	3.1	0.34	9.0	0.72		68.9	18.7	1011
Optimization Test #7B (30 cfh to P4-18, & P4-28 (60 cfh total); ~80% N2, 10% H2 & LPG)									
4/7/2008	1458	Start Test							
4/9/2008	1051	3.1	0.28	8.5	0.1		84.7	14.6	1009

Aerojet GEDIT - Injection Test Input

Phase II Piezometer Monitoring Data

Well ID P6

Depth 38

Date	Time	Well or Injection Gas Sample						Well	Ambient Air	
		O ₂ (%)	CO ₂ (%)	Propane (%)	H ₂ (%)	He (ppm)	RH (%)	Pressure (in wc)	Temperature (C°)	Barometric pressure (mbar)
Optimization Test #7C (50 cfh to P4-18, & P4-28 (100 cfh total); ~79% N2, 10% H2 & LPG, 1% CO2)										
4/10/2009	1121	Start Test								
4/11/2008	1227	2.8	0.36	9.0	0.1		68.6	21.6	1013	
4/14/2008	1011	3.2	0.38	8.0	0.046		79.8	15.7	1007	
4/16/2008	1021	3.1	0.38	7.5	0.1		67.6	15.2	1011	
4/22/2008	1044	2.6	0.42	6.5	0.022		81.4	19.9	1009	
4/23/2008	938	2.6	0.42	6.5	0.010		85.6	12.6	1010	
4/25/2008	951	2.2	0.34	6.5	0.10		78.3	19.5	1015	
4/29/2008	1102	2.1	0.42	7.0	0.046		63.5	25.2	1007	
5/5/2008	1306	1.5	0.44	7.0	0.1		64.8	33.1	1001	
5/13/2008	925	1.3	0.52	7.0	0.046		40.6	33.7	1007	
5/20/2008	926	0.8	0.60	7.5	0.046		69.0	23.3	1004	
5/23/2008	1511	0.7	0.44	7.5	0.10		51.0	31.0	990	
5/27/2008	856	0.8	0.68	8.0	0.022		70.3	16.4	1007	
6/4/2008	859	1.1	0.64	7.5	0.046		53.8	24.2	1002	
6/12/2008	1140	0.5	0.60	8.0	0.046		28.5	39.4	1003	
6/20/2008	1012	0.0	0.58	8.0	0.10		33.2	38.0	1006	
6/25/2008	1037	0.0	0.56	8.0	0.10		46.2	31.1	1005	
7/2/2008	1137	0.0	0.56	8.0	0.10		48.1	32.0	1004	
7/7/2008	1127	0	0.5	8	0.1		43	35.3	998	

Aerojet GEDIT - Injection Test Input

Phase II Piezometer Monitoring Data

Well ID P6

Depth 38

Date	Time	Well or Injection Gas Sample						Well	Ambient Air
		O ₂ (%)	CO ₂ (%)	Propane (%)	H ₂ (%)	He (ppm)	RH (%)	Pressure (in wc)	Temperature (C°)
7/18/2008	1054	0	0.6	8	0.1		80.4	25.3	
7/24/2008	1052	0.0	0.60	8.0	0.100		59.9	28.2	1005
7/31/2008	1050	0.0	0.64	8.0	0.100		60.4	26.7	1003
8/7/2008	926	0.0	0.62	8.0	0.10		60.6	26.4	1004
8/12/2008	1028	0.0	0.64	8.0	0.10		56.6	28.6	1002
Optimization Test #8 (100 cfh of 100% Propane to P4-18, & P4-28 (50 cfh to each point)									
9/8/2008	0905 Test Start								
9/8/2008	1032	0.7	0.7	10.5	0.022				999
9/15/2008	916	1.6	1.1	30	0.022		50.9	25.0	1007
9/29/2008	934	0.4	0.60	30	0.022		55.4	22.6	1006
10/13/2008	1157	1.0	0.44	30	0.022		31.4	31.4	1017
10/20/2008	1124	0.6	0.46	30	0.022		47.4	26.1	1013
11/5/2008	1400	0.4	0.48	30	0.022		77.9	18.7	1016
11/17/2008	1113	0.3	0.46	30	0.046		52.1	28.3	1014
12/1/2008	1114	0.1	0.44	30	0.022		53.5	23.2	1014

Aerojet GEDIT - Injection Test Input

Phase II Piezometer Monitoring Data

Well ID P6

Depth 48

Date	Time	Well or Injection Gas Sample						Well	Ambient Air		
		O ₂ (%)	CO ₂ (%)	Propane (%)	H ₂ (%)	He (ppm)	RH (%)	Pressure (in wc)	Temperature (C°)	Barometric pressure (mbar)	
12/12/2007	1200	20.8	0.00	0	0.002	80,000		0.02	11.9	1020	
12/12/2007	1536							0.10			
12/13/2007	907	20.7	0	0	0.22		75.0		7.4	1016	
12/13/2007	1002	19.1	0	0	0.22		63.6		13.2	1016	
12/13/2007	1200	Discovered leak in O2 - all O2 data for 12/13/07 before 1200 invalid									
12/13/2007	1345	9.4	0.62	0	1.4		69.2		16.0	1013	
12/13/2007	1510	6.7	0.64	0	2.8		78.9		13.9	1013	
12/13/2007	1542	5.8	0.66	0	3.4		78.4		13.2	1013	
12/14/2007	850	20.7	0.04	0	0.5		61.0	0.04	7.6	1017	
12/21/2007	1216	20.9	0	0	0.22		87.7	0.02	11.3	1012	
12/26/2007	1240	20.9	0	0	0.22		72.3	0.02	13.2	1016	
12/27/2007	1030	20.9	0	0	0.22		79.2	0.03	6	1018	
12/27/2007	1331	20.9	0	0	0.22		82.5		9.1	1016	
12/27/2007	1450	20.9	0	0	0.22		88.7		8.3	1017	
12/27/2007	1614	20.9	0	0	0.22		88.8	0.03	7.3	1017	
1/2/2008	1047	20.9	0.02	0	0.22		50.7	0.03	16.5	1012	

Tracer Test #1 (10 cfm to INJ2, ~7% H2)										
1/21/2008	1046 Test start									
1/21/2008	1215	9.9	0.52	0	0.81		79.0	0.06	10.3	1007

Aerojet GEDIT - Injection Test Input

Phase II Piezometer Monitoring Data

Well ID P6

Depth 48

Date	Time	Well or Injection Gas Sample						Well	Ambient Air	
		O ₂ (%)	CO ₂ (%)	Propane (%)	H ₂ (%)	He (ppm)	RH (%)	Pressure (in wc)	Temperature (C°)	Barometric pressure (mbar)
1/21/2008	1316	9.7	0.50	0	0.81		83.4		10.6	1006
1/21/2008	1511	9.7	0.52	0	0.74		80.0		11.1	1006
1/22/2008	1005	20.9	0.04	0	0.022		84.0	0.06	6.7	1011
1/22/2008	1410	20.9	0	0	0.022		84.2		8.8	1009
1/23/2008	1029	20.9	0.04	0	0.022		85.2	0.03	8.0	1008
1/23/2008	1127*	20.9								

Tracer Test #2 (20 cfm to INJ2, ~8% H2)										
1/18/2008	1120 Test start									
1/18/2008	1206	9.9	0.54	0	0.92		74.7		12.9	1015
1/18/2008	1308	9.5	0.54	0	0.98		67.3		14.9	1014
1/18/2008	1358	9.5	0.54	0	1.0		68.6		15.8	1014
1/18/2008	1535	9.1	0.54	0	1.1		46.1	0.04	23.7	1014
1/19/2008	1015	20.7**	0.08	0	0.022		70.5	0.01	9.7	1019
1/19/2008	1149*	20.2	0.08	0	0.046		72.2		12.6	1018

Tracer Test #3 (30 cfm to INJ2, ~4% H2)										
1/30/2008	1036 Test start									
1/30/2008	1115	5.3	0.42	0	2.0		91.1	0.03	9.7	1020
1/30/2008	1225	4.3	0.48	0	2.0		82.3		11.2	1019

Aerojet GEDIT - Injection Test Input

Phase II Piezometer Monitoring Data

Well ID P6

Depth 48

Date	Time	Well or Injection Gas Sample						Well	Ambient Air	
		O ₂ (%)	CO ₂ (%)	Propane (%)	H ₂ (%)	He (ppm)	RH (%)	Pressure (in wc)	Temperature (C°)	Barometric pressure (mbar)
1/30/2008	1426	3.4	0.56	0	2.2		71.6	0.06	13.7	1018
1/31/2008	954	0.9	0.80	0	1.9		86.7	0.05	8.9	1019
1/31/2008	1133	0.8	0.82	0	1.7		85.0		9.6	1018
1/31/2008	1345	0.7	0.80	0	1.7		80.2	0.06	8.8	1016
1/31/2008	1435									
1/31/2008	1517	4.1	0.82	0	0.88		84.2	0.03	8.3	1014

Tracer Test #4 (60 cfm to INJ2, ~7% H2)										
1/28/2008	1236 Test start									
1/28/2008	1306	16.0	0.26	0	0.022		91.3		10.6	1010
1/28/2008	1417	12.6	0.50	0	0.022		81.1	0.15	12.7	1011
1/28/2008	1559	10.3	0.56	0	0.022		77.8	0.07	12.1	1011
1/29/2008	803	3.2	0.94	0.02	3.4		86.3	0.04	4.9	1016
1/29/2008	1014*	2.8	0.98		3.6					

Tracer Test #5 (90 cfm to INJ2, ~3% H2)										
2/5/2008	1015 Test start									
2/5/2008	1037	14.6	0.10	0	0.010		68.2	0.06	9.6	1019
2/5/2008	1133	9.2	0.20	0	0.022		72.7		11.0	1019
2/5/2008	1343	5.2	0.36	0	0.022		78.0	0.10	12.7	1019

Aerojet GEDIT - Injection Test Input

Phase II Piezometer Monitoring Data

Well ID P6

Depth 48

Date	Time	Well or Injection Gas Sample						Well	Ambient Air	
		O ₂ (%)	CO ₂ (%)	Propane (%)	H ₂ (%)	He (ppm)	RH (%)	Pressure (in wc)	Temperature (C°)	Barometric pressure (mbar)
2/5/2008	1509	4.3	0.46	0	0.046		62.1		18.3	1019
2/5/2008	1553	3.8	0.48	0	0.046		57.4		18.9	1018

Tracer Test #6 (30 cfm total; 10 cfm to each INJ1, 2, and 3; ~8% H2)										
2/7/2008	1500 Test start									
2/7/2008	1534	1.1	0.54	0	1.0		53.3		22.0	1016
2/7/2008	1621	1.1	0.52	0	0.90		52.6		20.7	1016
2/8/2008	1016	17.5	0.40	0	0.022		67.1		10.1	1017

Tracer Test #7 (60 cfm total; 20 cfm to each INJ1, 2, and 3, ~5% H2)										
1/17/2008	900 Test start									
1/17/2008	1034	17.1	0.08	0	0.022		69.9	0.02	8.4	1016
1/17/2008	1146	15.9	0.20	0	0.22		75.0		9.9	1015
1/17/2008	1401	15.1	0.50	0	0.22		69.0		13.6	1013
1/17/2008	1523	14.5	0.60	0	0.22		52.0		19.8	1012

Tracer Test #8 (90 cfm total; 30 cfm each to INJ1, 2, and 3; ~4.5% H2)										
2/6/2008	1000 Test start									
2/6/2008	1039	3.5	0.40	0	0.10		78.3	0.06	11.1	1020
2/6/2008	1150	2.7	0.42	0	0.10		75.7		12.9	1020

Aerojet GEDIT - Injection Test Input

Phase II Piezometer Monitoring Data

Well ID P6

Depth 48

Date	Time	Well or Injection Gas Sample						Well	Ambient Air	
		O ₂ (%)	CO ₂ (%)	Propane (%)	H ₂ (%)	He (ppm)	RH (%)	Pressure (in wc)	Temperature (C°)	Barometric pressure (mbar)
2/6/2008	1247	2.3	0.44	0	0.046		73		14.4	1019
2/6/2008	1443	1.6	0.44	0	0.22		71.1	0.08	16.3	1017
2/6/2008	1539	1.4	0.44	0	0.61		60.8		18.8	1017
2/6/2008	1630	1.2	0.56	0	0.78		59.6		18.3	1017

Optimization Test #1 (90 cfm to INJ2 for 4 hours then shut down; ~88% N2, 10% H2, 1% CO2 & LPG)										
2/20/2008	1139	20.9	0.04	0	0.022		75.8		15.3	1010
2/20/2008	1206 Test start									
2/20/2008	1547	8.7	0.36	0	0.01		49.2		24.6	1008
2/20/2008	1606 Test End									
2/20/2008	1634	9.9	0.32	0	0.022		50.4		22.7	1008
2/21/2008	919	20.9	0.00	0	0.01		73.2		10.9	1005
2/22/2008	1045	20.9	0.00	0	0.022		82		10	1003

Optimization Test #2 (30 cfm to INJ2 for 12 hours then shut down; ~88% N2, 10% H2, 1% CO2 & LPG)										
2/25/2008	1845 Test Start									
2/26/2008	653 Test End									
2/26/2008	711	11.6	0.48	0.1	0.01		88		3.4	1017
2/27/2008	1539	19.6	0.04	0	0.022		35.2		37.7	1009
2/28/2008	1103	20.6	0	0	0.022		76.4		16.4	1007

Aerojet GEDIT - Injection Test Input

Phase II Piezometer Monitoring Data

Well ID P6

Depth 48

Date	Time	Well or Injection Gas Sample						Well	Ambient Air
		O ₂ (%)	CO ₂ (%)	Propane (%)	H ₂ (%)	He (ppm)	RH (%)	Pressure (in wc)	Temperature (C°)
Optimization Test #3A (1 cfm to INJ2; ~88% N2, 10% H2, 1% CO2 & LPG)									
2/29/2008	1319 Test Start								
2/29/2008	1439	18.9	0.00	0	0.022		71.3	25.3	1009
3/3/2008	1053	20.7	0	0	0.022		64.4	15.7	1019
3/3/2008	1130 Test End								
Optimization Test #3B (1 cfm to INJ1, INJ2 & INJ3; ~88% N2, 10% H2, 1% CO2 & LPG)									
3/3/2008	1130 Test Start								
3/4/2008	934	20.9	0	0	0.01		71.1	13	1013
3/7/2008	1110	20.1	0	0	0.005		64.6	18.5	1018
3/7/2008	1306 Test End								
Optimization Test #3C (90 cfm to INJ1, INJ2 & INJ3 for 15 minutes then shut down; ~79% N2, 10% H2 & LPG, 1% CO2)									
3/7/2008	1306 Start Pulse								
3/7/2008	1321 End Pulse								
3/10/2008	1059	20.2	0	0	0.005		68	16.7	1016
Optimization Test #4 (2, 45-minutes pulses; daily 15-minutes pulses w/30cfh constant flow)									

Aerojet GEDIT - Injection Test Input

Phase II Piezometer Monitoring Data

Well ID P6

Depth 48

Date	Time	Well or Injection Gas Sample						Well	Ambient Air
		O ₂ (%)	CO ₂ (%)	Propane (%)	H ₂ (%)	He (ppm)	RH (%)	Pressure (in wc)	Temperature (C°)
Optimization Test #5 (20 cfm to INJ2 for 125 minutes while maintaing 30 cfh the rest of the time; ~80% N2, 10% H2 & LPG)									
Optimization Test #6 (50 cfh to P4-18 & P4-28; ~80% N2, 10% H2 & LPG)									
3/20/2008	1330								
3/24/2008	1011	14.2	0.40	0.06	0.022		68.1	15.8	1012
3/26/2008	953	12.2	0.50	0.16	0.010		82.2	11.0	1017
3/28/2008	949	14.7	0.46	0.1	0.01		72.1	10.5	1009
3/31/2008	951	11.9	0.54	0.46	0.022		84.6	9.9	1013
4/2/2008	1049	10.0	0.60	1.02	0.022		78.5	15.2	1008
Optimization Test #7 (20 cfh to P4-18, --28, -38 (60 cfh total); ~80% N2, 10% H2 & LPG)									
4/2/2008	1233								
4/4/2008	934	9.3	0.62	1.30	0.022		72.7	12.7	1013
4/7/2008	1359	9.2	0.74	2.0	0.022		73.5	18.6	1011
Optimization Test #7B (30 cfh to P4-18, & P4-28 (60 cfh total); ~80% N2, 10% H2 & LPG)									
4/7/2008	1458								
4/9/2008	1053	6.9	0.72	5.0	0.022		82.0	14.8	1009

Aerojet GEDIT - Injection Test Input

Phase II Piezometer Monitoring Data

Well ID P6

Depth 48

Date	Time	Well or Injection Gas Sample						Well	Ambient Air	
		O ₂ (%)	CO ₂ (%)	Propane (%)	H ₂ (%)	He (ppm)	RH (%)	Pressure (in wc)	Temperature (C°)	Barometric pressure (mbar)
Optimization Test #7C (50 cfh to P4-18, & P4-28 (100 cfh total); ~79% N2, 10% H2 & LPG, 1% CO2)										
4/10/2009	1121	Start Test								
4/11/2008	1228	5.3	0.88	6.5	0.1		70.2	21.7	1013	
4/14/2008	1013	5.7	0.92	6.5	0.046		77.0	15.8	1007	
4/16/2008	1023	5.8	0.96	5.5	0.046		71.4	15.3	1011	
4/22/2008	1045	6.6	0.92	5.0	0.046		81.9	19.9	1009	
4/23/2008	940	5.0	0.98	6.5	0.010		88.7	12.6	1010	
4/25/2008	952	3.9	0.82	7.5	0.046		69.9	20.5	1015	
4/29/2008	1103	3.7	0.94	7.5	0.046		60.9	25.1	1007	
5/5/2008	1307	3.5	0.98	7.0	0.046		57.4	33.2	1001	
5/13/2008	926	2.8	1.04	7.5	0.046		35.0	34.0	1007	
5/20/2008	927	2.7	1.24	7.0	0.046		71.3	23.1	1004	
5/23/2008	1512	2.6	1.02	7.0	0.046		47.6	30.8	990	
5/27/2008	859	1.8	1.32	7.5	0.046		71.0	16.6	1007	
6/4/2008	900	1.7	1.30	7.5	0.046		57.2	24.2	1002	
6/12/2008	1144	1.5	1.16	7.0	0.022		30.9	39.5	1003	
6/20/2008	1014	1.0	1.20	7.0	0.022		37.4	38.6	1006	
6/25/2008	1038	0.9	1.22	7.0	0.10		46.7	31.2	1005	
7/2/2008	1139	0.7	1.26	7.0	0.10		55.2	31.9	1004	
7/7/2008	1129	0.5	1.16	7	0.046		46.7	35.7	998	

Aerojet GEDIT - Injection Test Input

Phase II Piezometer Monitoring Data

Well ID P6

Depth 48

Date	Time	Well or Injection Gas Sample						Well	Ambient Air
		O ₂ (%)	CO ₂ (%)	Propane (%)	H ₂ (%)	He (ppm)	RH (%)	Pressure (in wc)	Temperature (C°)
7/18/2008	1056	0.2	1.32	7	0.046		89.8		
7/24/2008	1053	0.2	1.30	7.0	0.100		60.0		1005
7/31/2008	1052	0.1	1.36	7.0	0.046		68.4		1003
8/7/2008	927	0.0	1.38	7.0	0.10		60.1		1004
8/12/2008	1029	0.0	1.30	7.0	0.10		57.1		1002
Optimization Test #8 (100 cfh of 100% Propane to P4-18, & P4-28 (50 cfh to each point)									
9/8/2008	0905 Test Start								
9/8/2008	1034	0.0	1.12	16.5	0.022				999
9/15/2008	917	0.8	1.3	30	0.022		49.1		1007
9/29/2008	936	0.1	1.18	30	0.022		52.8		1006
10/13/2008	1158	0.2	1.04	30	0.022		32.6		1017
10/20/2008	1126	0.2	1.08	30	0.010		50.6		1013
11/5/2008	1401	0.0	1.00	30	0.022		77.9		1016
11/17/2008	1114	0.0	0.88	30	0.022		54.2		1014
12/1/2008	1114	0.0	0.82	30	0.010		52.3		1014

Aerojet GEDIT - Injection Test Input

Phase II Piezometer Monitoring Data

Well ID P7

Depth 28

Date	Time	Well or Injection Gas Sample						Well	Ambient Air		
		O ₂ (%)	CO ₂ (%)	Propane (%)	H ₂ (%)	He (ppm)	RH (%)	Pressure (in wc)	Temperature (C°)	Barometric pressure (mbar)	
12/12/2007	1109	20.5	0.00	0	0.002	<100	81.7	0.01	10.2	1021	
12/12/2007	1540							0.11			
12/13/2007	1025	13.3	0	0	7.9		65.5		12.7	1016	
12/13/2007	1200	Discovered leak in O2 - all O2 data for 12/13/07 before 1200 invalid									
12/13/2007	1348	0	0	0	8.6		72.7		15.9	1013	
12/14/2007	854	0	0	0.04	0.5		65.6	0.02	7.0	1017	
12/21/2007	1228	18.0	0.02	0	0.46		80.3	0.04	10.7	1012	
12/26/2007	1243	18.6	0	0	0.022		76.4	0.04	12	1016	
12/27/2007	1043	5.7	0.06	0	6.5		80.8	0.04	5.5	1018	
12/27/2007	1333	4.6	0	0	7		78.7		9.2	1016	
12/27/2007	1454	3.7	0	0	7.5		84.6	0.04	8.4	1017	
1/2/2008	1050	0.2	0	0	0.22		53.1	0.04	16.4	10.2	

Tracer Test #1 (10 cfm to INJ2, ~7% H2)										
1/21/2008	1046 Test start									
1/21/2008	1219	2.6	0	0	0.046		73.8	0.04	10.4	1007
1/21/2008	1318	2.6	0	0	1.3		80.2		10.4	1006
1/21/2008	1517	2.4	0	0	4.5		75.8		10.9	1006
1/22/2008	1022	2.2	0	0	6.9		83.8	0.06	6.2	1011
1/22/2008	1416	1.8	0	0	7.0		82.8		8.6	1009

Aerojet GEDIT - Injection Test Input

Phase II Piezometer Monitoring Data

Well ID P7

Depth 28

Date	Time	Well or Injection Gas Sample						Well	Ambient Air	
		O ₂ (%)	CO ₂ (%)	Propane (%)	H ₂ (%)	He (ppm)	RH (%)	Pressure (in wc)	Temperature (C°)	Barometric pressure (mbar)
1/23/2008	1031	2.1	0	0	6.9		86.4	0.06	7.9	1008
1/23/2008	1128*	0.7								

Tracer Test #2 (20 cfm to INJ2, ~8% H2)										
1/18/2008	1120 Test start									
1/18/2008	1212	2.3	0	0	0.046		69.0		13.2	1015
1/18/2008	1257	2.1	0	0	2.1		63.4		14.2	1014
1/18/2008	1359	2.5	0	0	3.9		66.2		15.8	1014
1/18/2008	1537	2.1	0	0	6.4		45.8	0.02	23.9	1014
1/18/2008	1626	2.3	0	0	6.9		63.8		16.4	1014
1/18/2008	1633*	0.8	0	0	7.1		65.4		15.9	1014
1/18/2008	1639**	2.3	0	0	7.1		72.4		15.0	1014
1/19/2008	1023	2.0	0	0	9.4		67.3	0.01	9.7	1019
1/19/2008	1153*	0.6	0	0	7.9		96.0		14.1	1017

Tracer Test #3 (30 cfm to INJ2, ~4% H2)										
1/30/2008	1036 Test start									
1/30/2008	1118	0.0	0	0	0.57		89.2	0.06	9.7	1020
1/30/2008	1227	0.0	0	0	2.4		81.5		11.1	1019
1/30/2008	1428	0.0	0	0	4.4		75.5	0.09	13.8	1018

Aerojet GEDIT - Injection Test Input

Phase II Piezometer Monitoring Data

Well ID P7

Depth 28

Date	Time	Well or Injection Gas Sample						Well	Ambient Air	
		O ₂ (%)	CO ₂ (%)	Propane (%)	H ₂ (%)	He (ppm)	RH (%)	Pressure (in wc)	Temperature (C°)	Barometric pressure (mbar)
1/31/2008	955	0.0	0	0	4.2		85.3	0.10	8.9	1019
1/31/2008	1134	0	0	0	3.8		83.2		9.5	1018
1/31/2008	1353	0	0	0	3.7		82.9	0.08	8.8	1016
1/31/2008	1435									
1/31/2008	1519	0	0	0	3.7		85.0	0.03	8.3	1014
1/31/2008	1614	0	0	0	3.8		83.7		8.2	1013

Tracer Test #4 (60 cfm to INJ2, ~7% H2)										
1/28/2008	1236 Test start									
1/28/2008	1322	2.4	0	0	2.6		91.1		10.3	1010
1/28/2008	1419	0.5	0	0	5.0		82.8	0.13	12.5	1011
1/28/2008	1601	0.1	0	0	6.1		76.8	0.11	11.6	1012
1/29/2008	805	0.0	0	0	7.3		84.0	0.05	4.9	1016
1/29/2008	Final O2*									

Tracer Test #5 (90 cfm to INJ2, ~3% H2)										
2/5/2008	1015 Test start									
2/5/2008	1039	1.2	0	0	1.0		63.2	0.11	9.8	1019
2/5/2008	1135	0.1	0	0	2.6		68.4		11.0	1019
2/5/2008	1345	0	0	0	3.8		77.4	0.12	12.6	1018

Aerojet GEDIT - Injection Test Input

Phase II Piezometer Monitoring Data

Well ID P7

Depth 28

Date	Time	Well or Injection Gas Sample						Well	Ambient Air	
		O ₂ (%)	CO ₂ (%)	Propane (%)	H ₂ (%)	He (ppm)	RH (%)	Pressure (in wc)	Temperature (C°)	Barometric pressure (mbar)
2/5/2008	1511	0	0	0	3.6		64.3		19.3	1019
2/5/2008	1554	0	0	0	3.4		60.8		19.0	1018

Tracer Test #6 (30 cfm total; 10 cfm to each INJ1, 2, and 3; ~8% H2)										
2/7/2008	1500 Test start									
2/7/2008	1536	0.0	0	0	0.046		58.8		21.8	1016
2/7/2008	1624	0.0	0	0	0.10		56.6		20.6	1016
2/8/2008	1018	0.0	0	0	8.4		69.1		10.0	1017

Tracer Test #7 (60 cfm total; 20 cfm to each INJ1, 2, and 3, ~5% H2)										
1/17/2008	900 Test start									
1/17/2008	1038	11.3	0	0	1.5		67.8	0.02	8.5	1015
1/17/2008	1404	4.0	0	0	4.9		63.8		13.7	1013
1/17/2008	1535	3.2	0	0	5.5		48.5		18.8	1012

Tracer Test #8 (90 cfm total; 30 cfm each to INJ1, 2, and 3; ~4.5% H2)										
2/6/2008	1000 Test start									
2/6/2008	1041	0.0	0	0	0.61		76.9	0.15	11.1	1020
2/6/2008	1152	0.0	0	0	3.0		73.1		13.0	1020
2/6/2008	1249	0.0	0	0	3.8		72.7		14.5	1019

Aerojet GEDIT - Injection Test Input

Phase II Piezometer Monitoring Data

Well ID P7

Depth 28

Date	Time	Well or Injection Gas Sample						Well	Ambient Air	
		O ₂ (%)	CO ₂ (%)	Propane (%)	H ₂ (%)	He (ppm)	RH (%)	Pressure (in wc)	Temperature (C°)	Barometric pressure (mbar)
2/6/2008	1445	0.0	0	0	4.4		72.6	0.06	16.3	1017
2/6/2008	1541	0.0	0	0	4.4		62.6		19.5	1017

Optimization Test #1 (90 cfm to INJ2 for 4 hours then shut down; ~88% N2, 10% H2, 1% CO2 & LPG)										
2/20/2008	1140	9.5	0.00	0	0.046		75.7		15.3	1010
2/20/2008	1206 Test start									
2/20/2008	1552	0.0	0.20	1.02	11		50.2		24.4	1007
2/20/2008	1606 Test End									
2/20/2008	1635	0.0	0.12	1.02	10		52.8		22.3	1008
2/21/2008	929	7.4	0.08	0.4	3.9		74.6		10.4	1005
2/22/2008	1046	10.2	0.00	0.18	1.5		83.2		10.1	1003

Optimization Test #2 (30 cfm to INJ2 for 12 hours then shut down; ~88% N2, 10% H2, 1% CO2 & LPG)										
2/25/2008	1845 Test Start									
2/26/2008	653 Test End									
2/26/2008	713	0.1	0.76	0.62	7.2		89.2		3.6	1017
2/27/2008	1541	9.3	0.2	0.18	1		35.9		38.2	1009
2/28/2008	1105	10.5	0.02	0.14	0.1		73.5		16.4	1007

Aerojet GEDIT - Injection Test Input

Phase II Piezometer Monitoring Data

Well ID P7

Depth 28

Date	Time	Well or Injection Gas Sample						Well	Ambient Air
		O ₂ (%)	CO ₂ (%)	Propane (%)	H ₂ (%)	He (ppm)	RH (%)	Pressure (in wc)	Temperature (C°)
Optimization Test #3A (1 cfm to INJ2; ~88% N2, 10% H2, 1% CO2 & LPG)									
2/29/2008	1319 Test Start								
2/29/2008	1440	11	0.00	0.14	0.046		69.3	26.2	1009
3/3/2008	1055	11.3	0.04	0.18	0.046		60.7	15.7	1019
3/3/2008	1130 Test End								
Optimization Test #3B (1 cfm to INJ1, INJ2 & INJ3; ~88% N2, 10% H2, 1% CO2 & LPG)									
3/3/2008	1130 Test Start								
3/4/2008	935	12.3	0.04	0.16	0.022		65.6	13.1	1013
3/7/2008	1112	11.4	0	0.18	0.022		66.3	18.5	1018
3/7/2008	1306 Test End								
Optimization Test #3C (90 cfm to INJ1, INJ2 & INJ3 for 15 minutes then shut down; ~79% N2, 10% H2 & LPG, 1% CO2)									
3/7/2008	1306 Start Pulse								
3/7/2008	1321 End Pulse								
3/7/2008	1342	11.1	0	0.18	0.01		66.4	22.3	1016
3/10/2008	1101	11.7	0.06	0.2	0.022		71.3	16.8	1016
Optimization Test #4 (2, 45-minutes pulses; daily 15-minutes pulses w/30cfh constant flow)									

Aerojet GEDIT - Injection Test Input

Phase II Piezometer Monitoring Data

Well ID P7

Depth 28

Date	Time	Well or Injection Gas Sample						Well	Ambient Air
		O ₂ (%)	CO ₂ (%)	Propane (%)	H ₂ (%)	He (ppm)	RH (%)	Pressure (in wc)	Temperature (C°)
Optimization Test #5 (20 cfm to INJ2 for 125 minutes while maintaing 30 cfh the rest of the time; ~80% N2, 10% H2 & LPG)									
Optimization Test #6 (50 cfh to P4-18 & P4-28; ~80% N2, 10% H2 & LPG)									
3/20/2008	1330	Start Test							
3/21/2008	1018	7.2	0.00	3.0	0.046		80.9	12.7	1020
3/24/2008	1013	6.7	0.00	2.5	0.046		70.4	15.8	1012
3/26/2008	954	5.9	0.00	2.0	0.022		80.1	11.0	1017
3/28/2008	951	6.6	0.04	2.0	0.022		68.9	10.5	1009
3/31/2008	952	0.3	0.00	13.5	6.7		79.6	10.0	1013
4/2/2008	1051	0.1	0.00	14.0	6.0		73.6	15.4	1008
Optimization Test #7 (20 cfh to P4-18, --28, -38 (60 cfh total); ~80% N2, 10% H2 & LPG)									
4/2/2008	1233	Start Test							
4/4/2008	936	0.2	0.00	13.0	5.7		72.7	12.8	1013
4/7/2008	1405	7.5	0.06	6.5	2.0		89.0	18.7	1011
Optimization Test #7B (30 cfh to P4-18, & P4-28 (60 cfh total); ~80% N2, 10% H2 & LPG)									
4/7/2008	1458	Start Test							
4/9/2008	1057	8.9	0.00	4.5	1.0		83.6	15.0	1009

Aerojet GEDIT - Injection Test Input

Phase II Piezometer Monitoring Data

Well ID P7

Depth 28

Date	Time	Well or Injection Gas Sample						Well	Ambient Air	
		O ₂ (%)	CO ₂ (%)	Propane (%)	H ₂ (%)	He (ppm)	RH (%)	Pressure (in wc)	Temperature (C°)	Barometric pressure (mbar)
Optimization Test #7C (50 cfh to P4-18, & P4-28 (100 cfh total); ~79% N2, 10% H2 & LPG, 1% CO2)										
4/10/2009	1121	Start Test								
4/11/2008	1230	10.9	0.02	3.0	0.1		70.7	21.8	1013	
4/16/2008	1024	2.3	0.00	8.5	2.3		60.3	15.4	1011	
4/22/2008	1047	4.3	0.06	4.0	0.10		87.9	20.1	1009	
4/25/2008	955	1.8	0.02	7.5	0.046		66.2	21.3	1015	
4/29/2008	1105	0.9	0.00	8.0	1.0		63.6	24.6	1007	
5/5/2008	1309	1.5	0.02	7.5	0.82		56.5	33.2	1001	
5/13/2008	928	0.1	0.08	9.0	0.83		32.3	34.3	1007	
5/20/2008	928	5.8	0.14	5.0	0.046		58.1	22.8	1004	
5/23/2008	1514	4.0	0.10	7.0	0.046		41.6	30.7	990	
5/27/2008	900	1.1	0.20	8.5	1.4		56.0	16.5	1007	
6/4/2008	902	0.1	0.16	9.5	1.5		45.0	24.7	1002	
6/12/2008	1147	1.1	0.24	8.5	0.22		44.6	40.0	1003	
6/20/2008	1017	0.2	0.26	8.5	0.96		32.9	39.2	1006	
6/25/2008	1040	0.4	0.26	8.5	1.1		42.1	30.9	1005	
7/2/2008	1140	0.3	0.40	8.5	1.2		51.1	31.4	1004	
7/7/2008	1130	0.1	0.36	8.5	0.8		50.3	35.8	998	
7/18/2008	1057	0	0.44	8.5	1.2		89.8	25.5		
7/24/2008	1055	0.0	0.46	8.5	1.400		56.8	28.3	1005	

Aerojet GEDIT - Injection Test Input

Phase II Piezometer Monitoring Data

Well ID P7

Depth 28

Date	Time	Well or Injection Gas Sample						Well	Ambient Air	
		O ₂ (%)	CO ₂ (%)	Propane (%)	H ₂ (%)	He (ppm)	RH (%)	Pressure (in wc)	Temperature (C°)	Barometric pressure (mbar)
7/31/2008	1053	0.0	0.46	8.5	1.500		61.0		26.7	1003
8/7/2008	929	0.0	0.44	9.0	1.4		50.2		26.4	1004
8/12/2008	1031	0.0	0.46	9.0	1.2		55.1		28.4	1002
Optimization Test #8 (100 cfh of 100% Propane to P4-18, & P4-28 (50 cfh to each point)										
9/8/2008	0905 Test Start									
9/8/2008	1038	5.6	0.78	4.5	0.005					999
9/15/2008	919	3.2	0.94	9.5	0.010		36.2		25.6	1007
9/29/2008	938	5.1	1.70	19.5	0.005		42.3		23.9	1006
10/13/2008	1200	8.8	2.18	16.0	0.010		25.3		31.8	1017
10/20/2008	1127	6.2	3.00	21.5	0.010		46.6		25.6	1013
11/5/2008	1403	5.9	4.82	20.5	0.010		75.9		18.7	1016
11/17/2008	1116	5.0	5.00	25.5	0.010		54.1		28.2	1014
12/1/2008	1116	4.3	5.00	24.5	0.005		52.7		23.9	1014

Aerojet GEDIT - Injection Test Input

Phase II Piezometer Monitoring Data

Well ID P7

Depth 38

Date	Time	Well or Injection Gas Sample						Well	Ambient Air		
		O ₂ (%)	CO ₂ (%)	Propane (%)	H ₂ (%)	He (ppm)	RH (%)	Pressure (in wc)	Temperature (C°)	Barometric pressure (mbar)	
12/12/2007	1117	20.6	0.22	0	0.002	3,000	86.8	0.02	10.2	1020	
12/12/2007	1540							0.11			
12/13/2007	1021	13.3		0	8.2		62.7		12.7	1016	
12/13/2007	1200	Discovered leak in O2 - all O2 data for 12/13/07 before 1200 invalid									
12/13/2007	1349	0	0	0	8.6		73.9		15.6	1013	
12/14/2007	855	0	0.22	0	0.50		67.4	0.01	6.9	1016	
12/21/2007	1229	18.6	0.34	0	0.46		83.8	0.04	10.5	1012	
12/26/2007	1246	19	0.34	0	0.022		83.3	0.02	11.6	1016	
12/27/2007	1044	12.4	0.44	0	3.6		82.8	0.04	5.7	1018	
12/27/2007	1335	9.9	0.32	0	4.6		81.9		9.1	1016	
12/27/2007	1456	9.2	0.32	0	4.9		86.1	0.03	8.4	1017	
1/2/2008	1058	0.3	0.04	0	0.22		57.9	0.04	15	1012	

Tracer Test #1 (10 cfm to INJ2, ~7% H2)										
1/21/2008	1046 Test start									
1/21/2008	1220	2.5	0	0	0.10		72.4	0.04	10.4	1007
1/21/2008	1321	2.5	0.02	0	1.7		78.3		10.7	1006
1/21/2008	1519	2.4	0	0	4.0		73.1		10.8	1006
1/22/2008	1023	2.2	0.04	0	6.3		79.1	0.06	6.2	1011
1/22/2008	1417	1.9	0	0	6.4		79.4		8.6	1009

Aerojet GEDIT - Injection Test Input

Phase II Piezometer Monitoring Data

Well ID P7

Depth 38

Date	Time	Well or Injection Gas Sample						Well	Ambient Air	
		O ₂ (%)	CO ₂ (%)	Propane (%)	H ₂ (%)	He (ppm)	RH (%)	Pressure (in wc)	Temperature (C°)	Barometric pressure (mbar)
1/23/2008	1033	2.2	0.04	0	6.4		85.5	0.08	7.8	1008
1/23/2008	1129*	0.8								

Tracer Test #2 (20 cfm to INJ2, ~8% H2)										
1/18/2008	1120 Test start									
1/18/2008	1213	2.2	0.04	0	0.46		65.8		13.3	1015
1/18/2008	1258	2.0	0.06	0	2.8		62.4		14.3	1014
1/18/2008	1400	2.3	0.02	0	5.0		63.2		15.7	1014
1/18/2008	1539	1.9	0.02	0	6.5		43.8	0.04	24.0	1014
1/18/2008	1628	2.2	0	0	6.8		60.8		16.3	1014
1/18/2008	1632*	0.8	0	0	6.8		62.9		16.0	1014
1/18/2008	1641**	2.3	0	0	7.0		69.2		14.7	1014
1/19/2008	1024	2.0	0.08	0	8.9		62.8	0.02	9.8	1019
1/19/2008	1154	0.6	0.06	0	7.5		97.4		14.3	1017

Tracer Test #3 (30 cfm to INJ2, ~4% H2)										
1/30/2008	1036 Test start									
1/30/2008	1119	0.0	0	0	1.0		89.6	0.08	9.8	1020
1/30/2008	1229	0.0	0	0	3.3		80.7		11.3	1019
1/30/2008	1431	0.0	0	0	4.5		70.2	0.08	14.2	1018

Aerojet GEDIT - Injection Test Input

Phase II Piezometer Monitoring Data

Well ID P7

Depth 38

Date	Time	Well or Injection Gas Sample						Well	Ambient Air	
		O ₂ (%)	CO ₂ (%)	Propane (%)	H ₂ (%)	He (ppm)	RH (%)	Pressure (in wc)	Temperature (C°)	Barometric pressure (mbar)
1/31/2008	957	0.0	0	0	4.2		84.3	0.08	8.9	1019
1/31/2008	1135	0	0	0	3.8		83.1		9.5	1018
1/31/2008	1354	0	0	0	3.7		81.8	0.10	8.7	1016
1/31/2008	1435									
1/31/2008	1520	0	0	0	3.7		83.3	0.05	8.3	1014
1/31/2008	1615	0	0	0	3.9		82.5		8.1	1013

Tracer Test #4 (60 cfm to INJ2, ~7% H2)										
1/28/2008	1236 Test start									
1/28/2008	1336	0.8	0.04	0	4.6		92.2		10.6	1010
1/28/2008	1423	0.0	0.02	0	6.1		84.1	0.14	12.2	1011
1/28/2008	1603	0.0	0	0	6.4		77.8	0.12	11.3	1012
1/29/2008	807	0.0	0	0	7.3		84.0	0.04	5.0	1017
1/29/2008	Final O2*		0.0							

Tracer Test #5 (90 cfm to INJ2, ~3% H2)										
2/5/2008	1015 Test start									
2/5/2008	1042	0.1	0	0	2.4		61.4	0.10	9.9	1019
2/5/2008	1141	0	0	0	3.4		70.3		11.0	1019
2/5/2008	1346	0	0	0	3.9		76.7	0.13	12.6	1018

Aerojet GEDIT - Injection Test Input

Phase II Piezometer Monitoring Data

Well ID P7

Depth 38

Date	Time	Well or Injection Gas Sample						Well	Ambient Air	
		O ₂ (%)	CO ₂ (%)	Propane (%)	H ₂ (%)	He (ppm)	RH (%)	Pressure (in wc)	Temperature (C°)	Barometric pressure (mbar)
2/5/2008	1512	0	0	0	3.6		63.6		19.8	1019
2/5/2008	1556	0	0	0	3.5		60.7		19.1	1018

Tracer Test #6 (30 cfm total; 10 cfm to each INJ1, 2, and 3; ~8% H2)										
2/7/2008	1500 Test start									
2/7/2008	1537	0.0	0	0	0.046		59.7		21.7	1016
2/7/2008	1625	0.0	0	0	1.0		58.4		20.5	1016
2/8/2008	1019	0.0	0	0	8.5		68.8		8.9	1017

Tracer Test #7 (60 cfm total; 20 cfm to each INJ1, 2, and 3, ~5% H2)										
1/17/2008	900 Test start									
1/17/2008	1039	9.3	0.02	0	1.9		65.2	0.03	8.6	1015
1/17/2008	1406	4.1	0.12	0	4.8		63.3		13.7	1013
1/17/2008	1537	3.5	0.12	0	5.4		47.6		19.0	1012

Tracer Test #8 (90 cfm total; 30 cfm each to INJ1, 2, and 3; ~4.5% H2)										
2/6/2008	1000 Test start									
2/6/2008	1044	0.0	0	0	2.1		78.0	0.12	11.0	1020
2/6/2008	1153	0.0	0	0	3.6		73.0		13.2	1020
2/6/2008	1250	0.0	0	0	3.9		73.5		14.5	1019

Aerojet GEDIT - Injection Test Input

Phase II Piezometer Monitoring Data

Well ID P7

Depth 38

Date	Time	Well or Injection Gas Sample						Well	Ambient Air	
		O ₂ (%)	CO ₂ (%)	Propane (%)	H ₂ (%)	He (ppm)	RH (%)	Pressure (in wc)	Temperature (C°)	Barometric pressure (mbar)
2/6/2008	1446	0.0	0	0	4.6		73.9	0.12	16.4	1017
2/6/2008	1542	0.0	0	0	4.5		61.6		19.6	1017

Optimization Test #1 (90 cfm to INJ2 for 4 hours then shut down; ~88% N2, 10% H2, 1% CO2 & LPG)										
2/20/2008	1142	10.2	0.00	0	0.046		76.2		15.3	1010
2/20/2008	1206 Test start									
2/20/2008	1553	0.0	0.56	1.02	10		52.9		24.4	1008
2/20/2008	1606 Test End									
2/20/2008	1637	0.0	0.46	1.04	10		54.2		22	1007
2/21/2008	930	9.1	0.20	0.22	2.8		74.8		10.4	1005
2/22/2008	1048	11.1	0.14	0.1	1		80.8		10.2	1003

Optimization Test #2 (30 cfm to INJ2 for 12 hours then shut down; ~88% N2, 10% H2, 1% CO2 & LPG)										
2/25/2008	1845 Test Start									
2/26/2008	653 Test End									
2/26/2008	714	0.0	1.86	0.54	7.2		89.1		3.7	1017
2/27/2008	1543	10.1	0.6	0.12	0.65		34.9		38.6	1009
2/28/2008	1106	11.3	0.48	0.1	0.046		72.6		16.5	1007

Aerojet GEDIT - Injection Test Input

Phase II Piezometer Monitoring Data

Well ID P7

Depth 38

Date	Time	Well or Injection Gas Sample						Well	Ambient Air
		O ₂ (%)	CO ₂ (%)	Propane (%)	H ₂ (%)	He (ppm)	RH (%)	Pressure (in wc)	Temperature (C°)
Optimization Test #3A (1 cfm to INJ2; ~88% N2, 10% H2, 1% CO2 & LPG)									
2/29/2008	1319 Test Start								
2/29/2008	1445	11.8	0.40	0.12	0.022		56	29.1	1009
3/3/2008	1056	12.2	0.32	0.16	0.022		58.4	15.8	1019
3/3/2008	1130 Test End								
Optimization Test #3B (1 cfm to INJ1, INJ2 & INJ3; ~88% N2, 10% H2, 1% CO2 & LPG)									
3/3/2008	1130 Test Start								
3/4/2008	936	13	0.36	0.16	0.022		64.1	13.2	1013
3/7/2008	1113	12.2	0.2	0.16	0.022		70.9	18.7	1018
3/7/2008	1306 Test End								
Optimization Test #3C (90 cfm to INJ1, INJ2 & INJ3 for 15 minutes then shut down; ~79% N2, 10% H2 & LPG, 1% CO2)									
3/7/2008	1306 Start Pulse								
3/7/2008	1321 End Pulse								
3/7/2008	1343	11.6	0.18	0.16	0.046		67.3	22.4	1016
3/10/2008	1102	12.2	0.24	0.16	0.022		67.1	16.8	1016
Optimization Test #4 (2, 45-minutes pulses; daily 15-minutes pulses w/30cfh constant flow)									

Aerojet GEDIT - Injection Test Input

Phase II Piezometer Monitoring Data

Well ID P7

Depth 38

Date	Time	Well or Injection Gas Sample						Well	Ambient Air
		O ₂ (%)	CO ₂ (%)	Propane (%)	H ₂ (%)	He (ppm)	RH (%)	Pressure (in wc)	Temperature (C°)
Optimization Test #5 (20 cfm to INJ2 for 125 minutes while maintaing 30 cfh the rest of the time; ~80% N2, 10% H2 & LPG)									
Optimization Test #6 (50 cfh to P4-18 & P4-28; ~80% N2, 10% H2 & LPG)									
3/20/2008	1330	Start Test							
3/24/2008	1014	7.8	0.22	2.5	0.046		70.4	15.8	1012
3/26/2008	955	7.2	0.20	2.5	0.022		80.6	11.0	1017
3/28/2008	952	8.1	0.20	2.0	0.022		68.5	10.5	1009
3/31/2008	954	0.2	0.08	13.5	6.2		82.6	10.1	1013
4/2/2008	1052	0.1	0.10	14.0	5.3		76.6	15.5	1008
Optimization Test #7 (20 cfh to P4-18, --28, -38 (60 cfh total); ~80% N2, 10% H2 & LPG)									
4/2/2008	1233	Start Test							
4/4/2008	937	0.1	0.08	13.5	4.9		69.3	12.8	1013
4/7/2008	1406	5.8	0.06	8.0	1.3		81.2	18.6	1011
Optimization Test #7B (30 cfh to P4-18, & P4-28 (60 cfh total); ~80% N2, 10% H2 & LPG)									
4/7/2008	1458	Start Test							
4/9/2008	1059	6.4	0.00	6.5	0.72		79.8	145.2	1009

Aerojet GEDIT - Injection Test Input

Phase II Piezometer Monitoring Data

Well ID P7

Depth 38

Date	Time	Well or Injection Gas Sample						Well	Ambient Air	
		O ₂ (%)	CO ₂ (%)	Propane (%)	H ₂ (%)	He (ppm)	RH (%)	Pressure (in wc)	Temperature (C°)	Barometric pressure (mbar)
Optimization Test #7C (50 cfh to P4-18, & P4-28 (100 cfh total); ~79% N2, 10% H2 & LPG, 1% CO2)										
4/10/2009	1121	Start Test								
4/11/2008	1231	9.4	0.06	4.0	0.1		71.3	21.9	1013	
4/16/2008	1026	2.7	0.08	8.0	1.7		61.9	15.6	1011	
4/22/2008	1048	5.0	0.16	3.5	0.10		87.9	20.3	1009	
4/25/2008	956	0.8	0.14	8.5	0.046		61.6	21.6	1015	
4/29/2008	1106	1.1	0.06	8.0	0.22		65.6	24.5	1007	
5/5/2008	1311	1.9	0.06	7.0	0.1		55.9	33.6	1001	
5/13/2008	929	0.1	0.16	9.0	0.10		34.4	34.3	1007	
5/20/2008	930	5.2	0.28	6.0	0.022		61.0	22.8	1004	
5/23/2008	1515	4.8	0.26	7.0	0.046		41.8	30.7	990	
5/27/2008	901	2.4	0.34	8.0	0.86		58.5	16.5	1007	
6/4/2008	904	0.1	0.32	9.5	0.74		45.9	25.0	1002	
6/12/2008	1151	1.6	0.34	8.0	0.046		48.5	40.9	1003	
6/20/2008	1019	0.1	0.34	8.5	0.10		35.6	39.3	1006	
6/25/2008	1041	0.2	0.44	8.5	0.10		44.3	30.9	1005	
7/2/2008	1143	0.0	0.58	8.0	0.50		63.7	31.1	1004	
7/7/2008	1132	0	0.58	8.5	0.1		54.2	35.9	998	
7/18/2008	1058	0	0.68	8.5	0.77		93.8	25.6		
7/24/2008	1056	0.0	0.68	8.5	0.920		55.8	28.4	1005	

Aerojet GEDIT - Injection Test Input

Phase II Piezometer Monitoring Data

Well ID P7

Depth 38

Date	Time	Well or Injection Gas Sample						Well	Ambient Air
		O ₂ (%)	CO ₂ (%)	Propane (%)	H ₂ (%)	He (ppm)	RH (%)	Pressure (in wc)	Temperature (C°)
7/31/2008	1054	0.0	0.66	8.5	1.000		63.9	26.8	1003
8/7/2008	930	0.0	0.68	9.0	1.0		53.8	25.8	1004
8/12/2008	1032	0.0	0.64	8.5	0.82		54.4	28.4	1002
Optimization Test #8 (100 cfh of 100% Propane to P4-18, & P4-28 (50 cfh to each point)									
9/8/2008	0905 Test Start								
9/8/2008	1036	4.9	0.98	5.5	0.005				999
9/15/2008	920	2.3	1.38	16.5	0.010		38.8	25.7	1007
9/29/2008	940	3.9	2.12	30	0.010		39.1	24.2	1006
10/13/2008	1201	7.6	2.58	30	0.010		23.7	32.2	1017
10/20/2008	1129	4.9	3.18	30	0.010		47.7	25.5	1013
11/5/2008	1405	4.0	4.56	30	0.010		79.6	18.7	1016
11/17/2008	1117	3.7	4.90	30	0.010		54.5	28.1	1014
12/1/2008	1117	3.3	5.00	30	0.005		54.9	24.3	1014

Aerojet GEDIT - Injection Test Input

Phase II Piezometer Monitoring Data

Well ID P7

Depth 48

Date	Time	Well or Injection Gas Sample							Well	Ambient Air	
		O ₂ (%)	CO ₂ (%)	Propane (%)	H ₂ (%)	He (ppm)	RH (%)	Pressure (in wc)	Temperature (C°)	Barometric pressure (mbar)	
12/12/2007	1120	18.8	0.68	0	0.002	40,000	84.0	0.04	10.4	1020	
12/12/2007	1540							0.09			
12/13/2007	1019	19.8	0	0	0.022		55.1		13.0	1016	
12/13/2007	1200	Discovered leak in O2 - all O2 data for 12/13/07 before 1200 invalid									
12/13/2007	1350	18.0	0.82	0	0.22		80.1		15.2	1013	
12/14/2007	855	18.4	0.84	0	0.22		71.3	0.0	6.8	1017	
12/21/2007	1232	18.4	1.22	0	0.22		88.5	0.02	10.1	1012	
12/26/2007	1248	17.7	1.36	0	0.22		84.2	0.02	12.3		
12/27/2007	1046	17.9	1.42	0	0.22		81.2	0.03	6.1	1018	
12/27/2008	1337	17.6	1.2	0	0.22		82.2		9.1	1016	
12/27/2008	1457	17.6	1.18	0	0.22		86.4	0.02	8.3	1017	
1/2/2008	1101	17.3	1.58	0	0.22		61.7	0.04	14.6	1012	

Tracer Test #1 (10 cfm to INJ2, ~7% H2)										
1/21/2008	1046 Test start									
1/21/2008	1222	17.5	1.44	0	0.022		71.9	0.04	10.4	1007
1/21/2008	1322	17.4	1.50	0	0.046		76.4		10.8	1006
1/21/2008	1551	17.8	1.42	0	0.010		79.9		10.0	1006
1/22/2008	1025	18.0	1.46	0	0.022		78.4	0.04	6.2	1011
1/22/2008	1419	17.7	1.36	0	0.022		79.5		8.6	1009
1/23/2008	1035	17.9	1.62	0	0.022		84.8	0.04	7.8	1008
1/23/2008	1130*	17.6								

Aerojet GEDIT - Injection Test Input

Phase II Piezometer Monitoring Data

Well ID P7

Depth 48

Date	Time	Well or Injection Gas Sample							Well	Ambient Air
		O ₂ (%)	CO ₂ (%)	Propane (%)	H ₂ (%)	He (ppm)	RH (%)	Pressure (in wc)	Temperature (C°)	Barometric pressure (mbar)
Tracer Test #2 (20 cfm to INJ2, ~8% H2)										
1/18/2008	1120 Test start									
1/18/2008	1259	17.7	1.16	0	0.010		62.1		14.5	1014
1/18/2008	1402	17.7	1.16	0	0.022		62.0		15.7	1014
1/18/2008	1540	17.5	1.12	0	0.022		42.4	0.03	24.0	1014
1/18/2008	1630	17.7	1.12	0	0.022		59.7		16.2	1014
1/18/2008	1635*	17.5	1.26	0	0.022		64.5		15.7	1014
1/18/2008	1642**	17.7	1.16	0	0.022		68.2		14.8	1014
1/19/2008	1026	17.9	1.34	0	0.022		61.3	0.01	9.8	1019
1/19/2008	1157*	17.6	1.48	0	0.022		80.6		14.3	1017
Tracer Test #3 (30 cfm to INJ2, ~4% H2)										
1/30/2008	1036 Test start									
1/30/2008	1120	16.9	1.60	0	0.010		88.2	0.03	9.9	1020
1/30/2008	1230	16.9	1.58	0	0.010		80.0		11.2	1019
1/30/2008	1432	16.8	1.56	0	0.010		70.5	0.05	14.4	1018
1/31/2008	958	16.9	1.56	0	0.010		85.8	0.04	9.0	1019

Aerojet GEDIT - Injection Test Input

Phase II Piezometer Monitoring Data

Well ID P7

Depth 48

Date	Time	Well or Injection Gas Sample							Well	Ambient Air
		O ₂ (%)	CO ₂ (%)	Propane (%)	H ₂ (%)	He (ppm)	RH (%)	Pressure (in wc)	Temperature (C°)	Barometric pressure (mbar)
1/31/2008	1136	16.9	1.60	0	0.010			83.9	9.6	1018
1/31/2008	1358	17.0	1.62	0	0.010			80.1	0.08	1016
1/31/2008	1435									
1/31/2008	1521	16.9	1.62	0	0.010			82.8	0.03	1014
1/31/2008	1617	16.6	1.62	0	0.010			82.2	8.1	1013

Tracer Test #4 (60 cfm to INJ2, ~7% H2)										
1/28/2008	1236 Test start									
1/28/2008	1328	17.1	1.70	0	0.010			93.5	10.9	1010
1/28/2008	1425	16.9	1.78	0	0.005			82.0	0.05	1011
1/28/2008	1604	16.8	1.62	0	0.010			76.3	0.05	1011
1/29/2008	808	16.9	1.70	0.02	0.010			82.9	0.03	1017
1/29/2008	Final O2*									

Tracer Test #5 (90 cfm to INJ2, ~3% H2)										
2/5/2008	1015 Test start									
2/5/2008	1043	15.5	1.12	0	0.010			62.8	0.04	1019
2/5/2008	1142	15.5	1.08	0	0.010			69.1		1019
2/5/2008	1347	15.3	1.06	0	0.022			75.0	0.08	1018
2/5/2008	1513	15.7	1.18	0	0.010			58.6		1019
2/5/2008	1556	15.6	1.14	0	0.010			58.6		1018

Aerojet GEDIT - Injection Test Input

Phase II Piezometer Monitoring Data

Well ID P7

Depth 48

Date	Time	Well or Injection Gas Sample							Well	Ambient Air
		O ₂ (%)	CO ₂ (%)	Propane (%)	H ₂ (%)	He (ppm)	RH (%)	Pressure (in wc)	Temperature (C°)	Barometric pressure (mbar)
Tracer Test #6 (30 cfm total; 10 cfm to each INJ1, 2, and 3; ~8% H2)										
2/7/2008	1500 Test start									
2/7/2008	1538	15.9	1.30	0	0.005		61.1		21.5	1016
2/7/2008	1627	15.9	1.28	0	0.010		57.8		20.4	1016
2/8/2008	1020	15.7	1.22	0	0.022		69.1		10.0	1017
Tracer Test #7 (60 cfm total; 20 cfm to each INJ1, 2, and 3, ~5% H2)										
1/17/2008	900 Test start									
1/17/2008	1042	17.8	0.96	0	0.022		65.7	0.02	8.6	1015
1/17/2008	1406	18.0	1.40	0	0.22		61.8		13.5	1013
1/17/2008	1540	17.9	1.44	0	0.022		48.9		18.8	1012
Tracer Test #8 (90 cfm total; 30 cfm each to INJ1, 2, and 3; ~4.5% H2)										
2/6/2008	1000 Test start									
2/6/2008	1046	15.5	1.06	0	0.005		79.9	0.07	10.9	1020
2/6/2008	1155	15.5	1.06	0	0.005		76.5		13.2	1020
2/6/2008	1252	15.4	1.04	0	0.010		75		14.5	1019
2/6/2008	1446	15.3	1.02	0	0.022		76.4	0.07	16.3	1017
2/6/2008	1543	15.3	1.02	0	0.022		63.5		19.7	1017
2/6/2008	1632	15.9	1.24	0	0.005		60.0		19.0	1017

Aerojet GEDIT - Injection Test Input

Phase II Piezometer Monitoring Data

Well ID P7

Depth 48

Date	Time	Well or Injection Gas Sample							Well	Ambient Air	
		O ₂ (%)	CO ₂ (%)	Propane (%)	H ₂ (%)	He (ppm)	RH (%)	Pressure (in wc)	Temperature (C°)	Barometric pressure (mbar)	
Optimization Test #1 (90 cfm to INJ2 for 4 hours then shut down; ~88% N2, 10% H2, 1% CO2 & LPG)											
2/20/2008	1143	15.1	1.52	0	0.022			75.2		15.3	1010
2/20/2008	1206 Test start										
2/20/2008	1554	14.7	1.36	0	0.022			53.2		24	1008
2/20/2008	1606 Test End										
2/20/2008	1638	14.7	1.32	0	0.022			55.4		21.9	1008
2/21/2008	932	15.5	1.62	0	0.022			74.8		10.4	1005
2/22/2008	1054	15.3	1.62	0	0.005			84.5		10.4	1003
Optimization Test #2 (30 cfm to INJ2 for 12 hours then shut down; ~88% N2, 10% H2, 1% CO2 & LPG)											
2/25/2008	1845 Test Start										
2/26/2008	653 Test End										
2/26/2008	716	14.9	1.76	0.08	0.01			89.2		3.7	1017
2/27/2008	1544	14.6	1.4	0	0.022			35		38.8	1009
2/28/2008	1108	15.2	1.32	0	0.022			71.8		16.6	1007
Optimization Test #3A (1 cfm to INJ2; ~88% N2, 10% H2, 1% CO2 & LPG)											
2/29/2008	1319 Test Start										
2/29/2008	1446	14.5	1.08	0	0.005			58.3		29.3	1009
3/3/2008	1057	14.5	1.12	0	0.022			58.7		15.8	1019
3/3/2008	1130 Test End										

Aerojet GEDIT - Injection Test Input

Phase II Piezometer Monitoring Data

Well ID P7

Depth 48

Date	Time	Well or Injection Gas Sample							Well	Ambient Air
		O ₂ (%)	CO ₂ (%)	Propane (%)	H ₂ (%)	He (ppm)	RH (%)	Pressure (in wc)	Temperature (C°)	Barometric pressure (mbar)
Optimization Test #3B (1 cfm to INJ1, INJ2 & INJ3; ~88% N2, 10% H2, 1% CO2 & LPG)										
3/3/2008	1130 Test Start									
3/4/2008	937	14.9	1.36	0	0.01		65.7		13.3	1013
3/7/2008	1114	14.5	1.02	0	0.022		70		18.8	1018
3/7/2008	1306 Test End									
Optimization Test #3C (90 cfm to INJ1, INJ2 & INJ3 for 15 minutes then shut down; ~79% N2, 10% H2 & LPG, 1% CO2)										
3/7/2008	1306 Start Pulse									
3/7/2008	1321 End Pulse									
3/7/2008	1344	14.3	1	0	0.022		66.6		22.5	1016
3/10/2008	1103	14.7	1.14	0	0.022		66.4		16.8	1016
Optimization Test #4 (2, 45-minutes pulses; daily 15-minutes pulses w/30cfh constant flow)										
Optimization Test #5 (20 cfm to INJ2 for 125 minutes while maintaing 30 cfh the rest of the time; ~80% N2, 10% H2 & LPG)										
Optimization Test #6 (50 cfm to P4-18 & P4-28; ~80% N2, 10% H2 & LPG)										
3/20/2008	1330 Start Test									
3/26/2008	956*	6.0	0.02	2.0	0.046		85.3		11.1	1017
3/28/2008	953	15.1	1.52	0.00	0.010		72.4		10.6	1009
3/31/2008	956	14.7	1.28	0.04	0.022		82.8		10.1	1013
4/2/2008	1053	15.0	1.40	0.02	0.022		75.8		15.5	1008
Optimization Test #7 (20 cfh to P4-18, --28, -38 (60 cfh total); ~80% N2, 10% H2 & LPG)										
4/2/2008	1233 Start Test									

Aerojet GEDIT - Injection Test Input

Phase II Piezometer Monitoring Data

Well ID P7

Depth 48

Date	Time	Well or Injection Gas Sample							Well	Ambient Air
		O ₂ (%)	CO ₂ (%)	Propane (%)	H ₂ (%)	He (ppm)	RH (%)	Pressure (in wc)	Temperature (C°)	Barometric pressure (mbar)
4/4/2008	938	14.5	1.30	0.08	0.022			71.6	12.9	1013
4/7/2008	1407	13.5	1.38	0.52	0.022			79.7	18.7	1011
Optimization Test #7B (30 cfh to P4-18, & P4-28 (60 cfh total); ~80% N2, 10% H2 & LPG)										
4/7/2008	1458 Start Test									
4/9/2008	1100	12.9	1.24	0.8	0.022			78.4	15.3	1009
Optimization Test #7C (50 cfh to P4-18, & P4-28 (100 cfh total); ~79% N2, 10% H2 & LPG, 1% CO2)										
4/10/2009	1121 Start Test									
4/11/2008	1232	11.3	1.32	2.0	0.1			72.8	21.9	1013
4/16/2008	1027	10.4	1.34	2.5	0.0			62.2	15.6	1011
4/22/2008	1050	10.1	1.42	3.0	0.046			88.3	20.5	1009
4/25/2008	957	8.4	1.18	3.5	0.046			58.1	21.8	1015
4/29/2008	1108	10.0	1.34	3.0	0.046			64.5	24.7	1007
5/5/2008	1312	10.3	1.36	2.5	0.022			55.4	33.9	1001
5/13/2008	931	8.2	1.34	4.0	0.022			32.2	34.4	1007
5/20/2008	932	9.0	1.48	3.5	0.046			58.3	23.0	1004
5/23/2008	1516	11.5	1.44	1.6	0.010			41.0	30.3	990
5/27/2008	903	7.7	1.62	4.0	0.022			60.0	16.6	1007
6/4/2008	905	9.0	1.50	3.0	0.022			49.7	24.9	1002
6/12/2008	1154	6.8	1.40	3.5	0.010			46.6	41.4	1003
6/20/2008	1020	6.0	1.40	4.0	0.022			34.7	39.5	1006
6/25/2008	1042	5.6	1.44	4.0	0.046			43.5	31.1	1005
7/2/2008	1144	5.4	1.48	4.0	0.022			63.2	30.9	1004
7/7/2008	1133	6.5	1.44	3	0.022			52.3	36	998
7/18/2008	1059	4	1.64	4.5	0.046			93.3	25.5	

Aerojet GEDIT - Injection Test Input

Phase II Piezometer Monitoring Data

Well ID P7

Depth 48

Date	Time	Well or Injection Gas Sample							Well	Ambient Air
		O ₂ (%)	CO ₂ (%)	Propane (%)	H ₂ (%)	He (ppm)	RH (%)	Pressure (in wc)	Temperature (C°)	Barometric pressure (mbar)
7/24/2008	1058	3.6	1.64	4.5	0.046			57.7	28.4	1005
7/31/2008	1055	3.2	1.74	4.5	0.046			66.8	26.9	1003
8/7/2008	931	2.5	1.44	5.5	0.046			54.6	25.2	1004
8/12/2008	1033	3.0	1.78	4.5	0.046			63.8	28.3	1002
Optimization Test #8 (100 cfh of 100% Propane to P4-18, & P4-28 (50 cfh to each point))										
9/8/2008	0905 Test Start									
9/8/2008	1040	2.4	1.98	6.5	0.010					999
9/15/2008	922	1.1	2.06	30	0.010			35.6	25.6	1007
9/29/2008	941	0.1	2.08	30	0.010			37.1	24.3	1006
10/13/2008	1202	0.0	1.78	30	0.010			21.9	32.2	1017
10/20/2008	1131	0.1	1.84	30	0.005			49.4	26.2	1013
11/5/2008	1406	0.0	1.80	30	0.005			80.4	18.8	1016
11/17/2008	1118	0.0	1.64	30	0.005			55.3	27.8	1014
12/1/2008	1118	0.0	1.62	30	0.005			54.9	24.4	1014

Aerojet GEDIT - Injection Test Input

Phase II Piezometer Monitoring Data

Well ID P8

Depth 18

Date	Time	Well or Injection Gas Sample						Well	Ambient Air		
		O ₂ (%)	CO ₂ (%)	Propane (%)	H ₂ (%)	He (ppm)	RH (%)	Pressure (in wc)	Temperature (C°)	Barometric pressure (mbar)	
12/12/2007	1134	20.8	0.10	0	0.002	30,000	76.5	0.04	10.4	1020	
12/12/2007	1542							0.05			
12/13/2007	1029	13.2	0	0	8.0		64.5		12.6	1016	
12/13/2007	1200	Discovered leak in O2 - all O2 data for 12/13/07 before 1200 invalid									
12/13/2007	1351	0	0	0	8.7		68.4		14.6	1013	
12/14/2007	858	0.2	0.32	0.04	0.55		72.1	0.01	6.6	1017	
12/21/2007	1236	18.4	0.28	0	0.22		82.4	0.04	10.3	1012	
12/26/2007	1250	19.3	0.2	0	0.22		74.3	0.02	12.2	1016	
12/27/2007	1050	12.4	0.42	0	2.7		76.2	0.04	6.3	1018	
12/27/2007	1339	11.2	0.32	0	3.3		78.5		8.9	1016	
12/27/2007	1501	10.7	0.34	0	3.7		84.5	0.06	8.5	1017	
1/2/2008	1104	2.5	0.16	0	0.22		61.8	0.04	13.6	1012	

Tracer Test #1 (10 cfm to INJ2, ~7% H2)										
1/21/2008	1046 Test start									
1/21/2008	1223	3.7	0.10	0	0.046		72.8	0.05	10.4	1007
1/21/2008	1323	3.6	0.10	0	0.10		76.8		10.9	1006
1/21/2008	1553	3.6	0.04	0	2.6		74.7	0.07	10.0	1006
1/22/2008	1027	3.8	0.12	0	5.0		79.2	0.05	6.2	1011
1/22/2008	1420	3.3	0.06	0	5.3		79.8		8.5	1009

Aerojet GEDIT - Injection Test Input

Phase II Piezometer Monitoring Data

Well ID P8

Depth 18

Date	Time	Well or Injection Gas Sample						Well	Ambient Air	
		O ₂ (%)	CO ₂ (%)	Propane (%)	H ₂ (%)	He (ppm)	RH (%)	Pressure (in wc)	Temperature (C°)	Barometric pressure (mbar)
1/23/2008	1036	3.7	0.10	0	5.7		84.9	0.04	7.9	1008
1/23/2008	1138*	1.3								

Tracer Test #2 (20 cfm to INJ2, ~8% H2)										
1/18/2008	1120 Test start									
1/18/2008	1249	3.0	0.08	0	0.10		67.2		13.9	1014
1/18/2008	1403	3.4	0.04	0	3.8		63.7		15.7	1014
1/18/2008	1541	2.9	0.02	0	5.4		42.9	0.03	24.3	1014
1/19/2008	1032	3.0	0.08	0	9.0		60.2	0.01	10.0	1019
1/19/2008	1200*	0.7	0.10	0	7.6		61.4		14.6	1018

Tracer Test #3 (30 cfm to INJ2, ~4% H2)										
1/30/2008	1036 Test start									
1/30/2008	1123	0.1	0	0	0.46		91.2	0.07	9.9	1020
1/30/2008	1232	0.1	0	0	2.4		82.9		11.2	1019
1/30/2008	1435	0.1	0	0	4.2		74.0	0.09	14.7	1018
1/31/2008	1000	0.1	0	0	4.1		85.9	0.08	9.1	1019
1/31/2008	1138	0.1	0	0	3.7		83.2		9.6	1018
1/31/2008	1400	0.1	0	0	3.7		80.6	0.08	8.7	1016
1/31/2008	1435									
1/31/2008	1523	0.1	0	0	3.6		82.2	0.06	8.3	1014

Aerojet GEDIT - Injection Test Input

Phase II Piezometer Monitoring Data

Well ID P8

Depth 18

Date	Time	Well or Injection Gas Sample						Well	Ambient Air
		O ₂ (%)	CO ₂ (%)	Propane (%)	H ₂ (%)	He (ppm)	RH (%)	Pressure (in wc)	Temperature (C°)

Tracer Test #4 (60 cfm to INJ2, ~7% H2)										
1/28/2008	1236	Test start								
1/28/2008	1330	3.4	0.16	0	2.5		88.0	11.4	1010	
1/28/2008	1429	0.3	0.10	0	5.6		82.4	0.04	12.3	
1/28/2008	1606	0.1	0.02	0	6.1		77.0	0.10	10.8	
1/29/2008	811	0.0	0	0.02	7.2		84.2	0.03	5.1	
1/29/2008	1012*	0.1			6.5					

Tracer Test #5 (90 cfm to INJ2, ~3% H2)										
2/5/2008	1015	Test start								
2/5/2008	1044	1.4	0	0	0.84		65.4	0.08	10.2	
2/5/2008	1144	0.1	0	0	3.1		73.8		11.1	
2/5/2008	1348	0.0	0	0	3.8		79.5	0.10	12.6	
2/5/2008	1514	0.0	0	0	3.5		51.1		20.9	
2/5/2008	1558	0.0	0	0	3.4		62.2		19.2	

Tracer Test #6 (30 cfm total; 10 cfm to each INJ1, 2, and 3; ~8% H2)										
2/7/2008	1500	Test start								
2/7/2008	1540	0.1	0	0	0.046		63		21.5	
2/7/2008	1629	0.0	0	0	0.10		59.1		20.1	
2/8/2008	1022	0.0	0	0	8.5		69.3		10.0	

Aerojet GEDIT - Injection Test Input

Phase II Piezometer Monitoring Data

Well ID P8

Depth 18

Date	Time	Well or Injection Gas Sample						Well	Ambient Air	
		O ₂ (%)	CO ₂ (%)	Propane (%)	H ₂ (%)	He (ppm)	RH (%)	Pressure (in wc)	Temperature (C°)	Barometric pressure (mbar)
Tracer Test #7 (60 cfm total; 20 cfm to each INJ1, 2, and 3, ~5% H2)										
1/17/2008	900 Test start									
1/17/2008	1045	10.8	0.06	0	1.8		64.4	0.03	8.6	1015
1/17/2008	1410	4.8	0.22	0	4.8		62.4		13.3	1013
1/17/2008	1542	3.4	0.22	0	5.6		47.3	0.01	18.6	1012
Tracer Test #8 (90 cfm total; 30 cfm each to INJ1, 2, and 3; ~4.5% H2)										
2/6/2008	1000 Test start									
2/6/2008	1048	0.1	0	0	0.22		82.6	0.11	10.9	1020
2/6/2008	1158	0.0	0	0	3.2		79.7		13.2	1020
2/6/2008	1253	0.1	0	0	3.7		78.0		14.4	1019
2/6/2008	1448	0.0	0	0	4.3		80.4	0.11	16.4	1017
2/6/2008	1544	0.0	0	0	4.3		63.6		19.7	1017
Optimization Test #1 (90 cfm to INJ2 for 4 hours then shut down; ~88% N2, 10% H2, 1% CO2 & LPG)										
2/20/2008	1144	11.4	0.02	0	0.022		74.7		15.4	1010
2/20/2008	1206 Test start									
2/20/2008	1556	0.1	0.76	1	11		55		23.8	1008
2/20/2008	1606 Test End									
2/20/2008	1640	0.1	0.72	1.02	9.9		57.3		21.6	1008
2/21/2008	934	7.6	0.46	0.44	4.2		75.8		10.4	1005
2/22/2008	1055	10.1	0.34	0.26	1.6		82.7		10.4	1003

Aerojet GEDIT - Injection Test Input

Phase II Piezometer Monitoring Data

Well ID P8

Depth 18

Date	Time	Well or Injection Gas Sample						Well	Ambient Air
		O ₂ (%)	CO ₂ (%)	Propane (%)	H ₂ (%)	He (ppm)	RH (%)	Pressure (in wc)	Temperature (C°)
Optimization Test #2 (30 cfm to INJ2 for 12 hours then shut down; ~88% N2, 10% H2, 1% CO2 & LPG)									
2/25/2008	1845 Test Start								
2/26/2008	653 Test End								
2/26/2008	718	0.1	2.36	0.56	7		89.3	3.8	1017
2/27/2008	1546	8.7	0.96	0.24	1.5		35.3	39.2	1009
2/28/2008	1110	9.7	0.78	0.22	0.61		71.3	16.7	1007
Optimization Test #3A (1 cfm to INJ2; ~88% N2, 10% H2, 1% CO2 & LPG)									
2/29/2008	1319 Test Start								
2/29/2008	1448	10.2	0.60	0.22	0.046		58.1	29.6	1009
3/3/2008	1102	11.3	0.42	0.18	0.022		75.3	16	1019
3/3/2008	1130 Test End								
Optimization Test #3B (1 cfm to INJ1, INJ2 & INJ3; ~88% N2, 10% H2, 1% CO2 & LPG)									
3/3/2008	1130 Test Start								
3/4/2008	944	10.8	0.44	0.22	0.022		78.5	13.8	1013
3/7/2008	1116	10.1	0.22	0.26	0.005		66.5	19	1018
3/7/2008	1306 Test End								
Optimization Test #3C (90 cfm to INJ1, INJ2 & INJ3 for 15 minutes then shut down; ~79% N2, 10% H2 & LPG, 1% CO2)									
3/7/2008	1306 Start Pulse								
3/7/2008	1321 End Pulse								
3/7/2008	1345	11.1	0.18	0.22	0.01		68.6	22.6	1016
3/10/2008	1104	11	0.24	0.24	0.005		66.8	16.8	1016

Aerojet GEDIT - Injection Test Input

Phase II Piezometer Monitoring Data

Well ID P8

Depth 18

Date	Time	Well or Injection Gas Sample						Well	Ambient Air
		O ₂ (%)	CO ₂ (%)	Propane (%)	H ₂ (%)	He (ppm)	RH (%)	Pressure (in wc)	Temperature (C°)
Optimization Test #4 (2, 45-minutes pulses; daily 15-minutes pulses w/30cfh constant flow)									
Optimization Test #5 (20 cfm to INJ2 for 125 minutes while maintaing 30 cfh the rest of the time; ~80% N2, 10% H2 & LPG)									
Optimization Test #6 (50 cfh to P4-18 & P4-28; ~80% N2, 10% H2 & LPG)									
3/20/2008	1330 Start Test								
3/21/2008	1020	20.9	0	0	0.01		76.6	12.7	1020
3/26/2008	958	20.9	0	0	0.01		83.3	11.1	1017
3/28/2008	955	20.9	0	0	0.005		73.5	10.6	1009
3/31/2008	958	20.9	0	0	0.005		75.8	15.6	1013
4/2/2008	1224*	6.5	0.16	6.5	3.9		85.2	18.5	1008
*Tubing to P8-18 was disconnected; all data from 3/21/08 - 4/2/08 @1054 invalid									
Optimization Test #7 (20 cfh to P4-18, --28, -38 (60 cfh total); ~80% N2, 10% H2 & LPG)									
4/2/2008	1233 Start Test								
4/4/2008	939	6.6	0.20	6.0	2.5		70.8	12.9	1013
4/7/2008	1409	7.8	0.28	6.5	2.7		79.8	18.6	1011
Optimization Test #7B (30 cfh to P4-18, & P4-28 (60 cfh total); ~80% N2, 10% H2 & LPG)									
4/7/2008	1458 Start Test								
4/9/2008	1103	11.9	0.22	3.0	1.4		79.3	15.4	1009

Aerojet GEDIT - Injection Test Input

Phase II Piezometer Monitoring Data

Well ID P8

Depth 18

Date	Time	Well or Injection Gas Sample					RH (%)	Pressure (in wc)	Well	Ambient Air
		O ₂ (%)	CO ₂ (%)	Propane (%)	H ₂ (%)	He (ppm)			Temperature (C°)	Barometric pressure (mbar)
Optimization Test #7C (50 cfh to P4-18, & P4-28 (100 cfh total); ~79% N2, 10% H2 & LPG, 1% CO2)										
4/10/2009	1121 Start Test									
4/11/2008	1234	12.9	0.32	2.0	0.7			21.9	1013	
4/16/2008	1029	10.8	0.20	3.5	0.8			15.7	1011	
4/22/2008	1051	4.8	0.32	4.5	1.4			20.1	1009	
4/25/2008	959	7.8	0.18	4.0	0.10			22.1	1015	
4/29/2008	1109	2.3	0.26	7.5	1.7			24.3	1007	
5/5/2008	1314	3.5	0.28	6.5	1.9			34.6	1001	
5/13/2008	934	2.2	0.26	8.0	0.96			34.2	1007	
5/20/2008	933	10.3	0.54	3.5	0.86			22.7	1004	
5/23/2008	1519	9.0	0.28	4.0	0.10			30.0	990	
5/27/2008	905	6.3	0.60	6.5	1.8			16.7	1007	
6/4/2008	907	1.4	0.58	9.0	2.1			25.2	1002	
6/12/2008	1156	3.6	0.42	7.5	0.93			42.0	1003	
6/20/2008	1023	1.0	0.52	8.5	1.7			40.4	1006	
6/25/2008	1048	1.1	0.6	8.0	2.5			32.6	1005	
7/2/2008	1146	1.1	0.64	8.0	2.1			30.7	1004	
7/7/2008	1136	0.5	0.58	8.5	1.4			36.1	998	
7/18/2008	1101	0.2	0.64	8.5	1.8			25.6		
7/24/2008	1059	0.4	0.54	8.5	1.900			28.4	1005	
7/31/2008	1058	0.0	0.56	9.0	1.900			27.2	1003	
8/7/2008	933	0.0	0.60	9.0	1.8			24.7	1004	
8/12/2008	1038	0.0	0.56	9.0	1.5			28.2	1002	

Aerojet GEDIT - Injection Test Input

Phase II Piezometer Monitoring Data

Well ID P8

Depth 18

Date	Time	Well or Injection Gas Sample						Well	Ambient Air
		O ₂ (%)	CO ₂ (%)	Propane (%)	H ₂ (%)	He (ppm)	RH (%)	Pressure (in wc)	Temperature (C°)
Optimization Test #8 (100 cfh of 100% Propane to P4-18, & P4-28 (50 cfh to each point)									
9/8/2008	0905 Test Start								
9/8/2008	1045	10.2	0.82	2.5	0.005				999
9/15/2008	926	9.1	1.02	3.5	0.005		36.7	26.3	1007
9/29/2008	950	12.0	1.12	2.5	0.002		62.4	22.3	1006
10/13/2008	1205	16.2	1.08	0.90	0.010		22.6	31.5	1017
10/20/2008	1133	14.8	1.36	1.76	0.005		48.1	26.6	1013
11/5/2008	1408	17.1	1.46	0.84	0.005		76.1	18.8	1016
11/17/2008	1120	15.7	1.46	1.62	0.005		62.9	27.2	1014
12/1/2008	1120	16.4	1.42	1.32	0.005		56.2	24.7	1014

Aerojet GEDIT - Injection Test Input

Phase II Piezometer Monitoring Data

Well ID P8

Depth 28

Date	Time	Well or Injection Gas Sample						Well	Ambient Air	
		O ₂ (%)	CO ₂ (%)	Propane (%)	H ₂ (%)	He (ppm)	RH (%)	Pressure (in wc)	Temperature (C°)	Barometric pressure (mbar)
12/12/2007	1140	20.7	0.04	0	0.002	50,000	77.7	0.02	10.7	1020
12/12/2007	1541							0.06		
12/13/2007	1031	14.1	0	0	7.0		61.8		12.8	1016
12/13/2007	1200	Discovered leak in O2 - all O2 data for 12/13/07 before 1200 invalid								
12/13/2007	1353	0.2	0.1	0	8.4		71.8		14.3	1013
12/14/2007	859	0.8	0.28	0.14	0.88		69.6	0.0	6.5	1017
12/21/2007	1238	19.0	0.18	0	0.22		86.2	0.03	10.4	1012
12/26/2007	1253	20	0.14	0	0.022		78.2	0.01	11.6	1016
12/27/2007	1053	13.5	0.18	0	2.5		79.9	0.02	6.3	1018
12/27/2007	1341	12.4	0.1	0	3		82.2		9	1016
12/27/2007	1504	11.8	0.1	0	3.5		85.4	0.02	8.5	1017
1/2/2008	1107	3.3	0.18	0	0.22		62.6	0.03	13.4	1012

Tracer Test #1 (10 cfm to INJ2, ~7% H2)										
1/21/2008	1046 Test start									
1/21/2008	1225	4.6	0.12	0	0.046		76.5	0.02	10.4	1007
1/21/2008	1325	4.5	0.10	0	0.046		80.9		11.1	1006
1/21/2008	1554	4.0	0.10	0	0.79		79.4	0.05	10.0	1006
1/22/2008	1028	3.4	0.08	0	4.6		80.5	0.04	6.3	1011
1/22/2008	1422	2.9	0.02	0	4.9		82.7		8.6	1009

Aerojet GEDIT - Injection Test Input

Phase II Piezometer Monitoring Data

Well ID P8

Depth 28

Date	Time	Well or Injection Gas Sample						Well	Ambient Air	
		O ₂ (%)	CO ₂ (%)	Propane (%)	H ₂ (%)	He (ppm)	RH (%)	Pressure (in wc)	Temperature (C°)	Barometric pressure (mbar)
1/23/2008	1038	3.2	0.06	0	5.4		85.8	0.02	7.6	1008
1/23/2008	1132*	1.2								

Tracer Test #2 (20 cfm to INJ2, ~8% H2)										
1/18/2008	1120 Test start									
1/18/2008	1251	3.7	0.16	0	0.10		68.2		14.8	1014
1/18/2008	1405	3.8	0.12	0	1.0		64.7		15.8	1014
1/18/2008	1543	2.9	0.12	0	3.8		45.0	0.02	24.7	1014
1/19/2008	1033	2.9	0.08	0	9.5		59.2	0.01	10.1	1019
1/19/2008	1201*	0.8	0.10	0	8.6		69.2		14.8	1018

Tracer Test #3 (30 cfm to INJ2, ~4% H2)										
1/30/2008	1036 Test start									
1/30/2008	1124	0.2	0.04	0	0.93		90.4	0.08	10.0	1020
1/30/2008	1233	0.1	0.02	0	0.87		84.2		11.1	1019
1/30/2008	1436	0.0	0.02	0	3.2		73.5	0.08	15.0	1018
1/31/2008	1001	0.0	0	0	4.1		86.0	0.07	9.2	1019
1/31/2008	1138	0	0	0	3.7		83.5		9.6	1018
1/31/2008	1401	0	0	0	3.6		80.8	0.10	8.7	1016
1/31/2008	1435									
1/31/2008	1524	0.1	0	0	3.6		82.2	0.08	8.3	1014

Aerojet GEDIT - Injection Test Input

Phase II Piezometer Monitoring Data

Well ID P8

Depth 28

Date	Time	Well or Injection Gas Sample						Well	Ambient Air
		O ₂ (%)	CO ₂ (%)	Propane (%)	H ₂ (%)	He (ppm)	RH (%)	Pressure (in wc)	Temperature (C°)

Tracer Test #4 (60 cfm to INJ2, ~7% H2)										
1/28/2008	1236	Test start								
1/28/2008	1331	11.1	0.06	0	0.046			89.6	11.6	1010
1/28/2008	1431	2.7	0.08	0	3.9			83.7	12.6	1011
1/28/2008	1607	0.5	0.04	0	5.3			78.3	10.7	1012
1/29/2008	813	0.1	0.04	0	7.1			83.6	5.1	1017
1/29/2008	1013*	0.2			6.4					

Tracer Test #5 (90 cfm to INJ2, ~3% H2)										
2/5/2008	1015	Test start								
2/5/2008	1046	5.6	0	0	0.022			63.5	10.3	1019
2/5/2008	1145	1.4	0	0	1.8			72.5	11.1	1019
2/5/2008	1349	0.5	0	0	3.2			80.1	12.6	1018
2/5/2008	1515	0.3	0	0	3.0			55.6	21.2	1019
2/5/2008	1559	0.2	0	0	3.0			64.1	19.1	1018

Tracer Test #6 (30 cfm total; 10 cfm to each INJ1, 2, and 3; ~8% H2)										
2/7/2008	1500	Test start								
2/7/2008	1541	0.0	0.06	0	0.10			63.2	21.6	1016
2/7/2008	1630	0.0	0.04	0	0.10			59.7	20.1	1016
2/8/2008	1023	0.0	0	0	8.3			68.3	10.0	1017

Aerojet GEDIT - Injection Test Input

Phase II Piezometer Monitoring Data

Well ID P8

Depth 28

Date	Time	Well or Injection Gas Sample						Well	Ambient Air
		O ₂ (%)	CO ₂ (%)	Propane (%)	H ₂ (%)	He (ppm)	RH (%)	Pressure (in wc)	Temperature (C°)

Tracer Test #7 (60 cfm total; 20 cfm to each INJ1, 2, and 3, ~5% H2)										
1/17/2008	900 Test start									
1/17/2008	1051	18.0	0	0	0.22		65.5	0.02	8.7	1015
1/17/2008	1412	6.1	0.16	0	4.4		66.2		13.3	1013
1/17/2008	1544	4.8	0.18	0	5.0		48.9	0.02	19.0	1012

Tracer Test #8 (90 cfm total; 30 cfm each to INJ1, 2, and 3; ~4.5% H2)										
2/6/2008	1000 Test start									
2/6/2008	1049	0.2	0	0	0.64		81.2	0.09	10.9	1020
2/6/2008	1159	0.0	0	0	1.3		78.4		13.2	1020
2/6/2008	1255	0.0	0	0	2.4		79.8		14.5	1019
2/6/2008	1448	0.0	0	0	3.8		80.9	0.11	16.2	1017
2/6/2008	1546	0.0	0	0	3.9		65.7		19.7	1017
2/6/2008	1635	0.0	0	0	3.9		60.2		19.4	1017

Optimization Test #1 (90 cfm to INJ2 for 4 hours then shut down; ~88% N2, 10% H2, 1% CO2 & LPG)										
2/20/2008	1145	11.3	0.00	0	0.022		74.4		15.4	1010
2/20/2008	1206 Test start									
2/20/2008	1557	0.6	0.32	0.96	10		55.4		23.7	1008
2/20/2008	1606 Test End									
2/20/2008	1641	0.5	0.30	0.96	10		58.5		21.3	1008

Aerojet GEDIT - Injection Test Input

Phase II Piezometer Monitoring Data

Well ID P8

Depth 28

Date	Time	Well or Injection Gas Sample						Well	Ambient Air
		O ₂ (%)	CO ₂ (%)	Propane (%)	H ₂ (%)	He (ppm)	RH (%)	Pressure (in wc)	Temperature (C°)
2/21/2008	935	4.2	0.28	0.72	4.9		75.3	10.8	1005
2/22/2008	1056	8.3	0.20	0.38	1.8		82.3	10.4	1003

Optimization Test #2 (30 cfm to INJ2 for 12 hours then shut down; ~88% N2, 10% H2, 1% CO2 & LPG)									
2/25/2008	1845 Test Start								
2/26/2008	653 Test End								
2/26/2008	719	0.2	1.3	0.62	6.6		87.7	3.9	1017
2/27/2008	1547	5.6	0.76	0.34	1.5		34.9	39.2	1009
2/28/2008	1111	7.9	0.62	0.3	0.69		70.3	16.7	1007
Optimization Test #3A (1 cfm to INJ2; ~88% N2, 10% H2, 1% CO2 & LPG)									
2/29/2008	1319 Test Start								
2/29/2008	1449	8.8	0.46	0.28	0.046		58.8	29.7	1009
3/3/2008	1103	11	0.24	0.18	0.022		63.5	16	1019
3/3/2008	1130 Test End								

Optimization Test #3B (1 cfm to INJ1, INJ2 & INJ3; ~88% N2, 10% H2, 1% CO2 & LPG)									
3/3/2008	1130 Test Start								
3/4/2008	945	10	0.26	0.24	0.022		67.9	13.8	1013
3/7/2008	1118	9.1	0.12	0.28	0.01		66.1	19.4	1018
3/7/2008	1306 Test End								

Aerojet GEDIT - Injection Test Input

Phase II Piezometer Monitoring Data

Well ID P8

Depth 28

Date	Time	Well or Injection Gas Sample						Well	Ambient Air
		O ₂ (%)	CO ₂ (%)	Propane (%)	H ₂ (%)	He (ppm)	RH (%)	Pressure (in wc)	Temperature (C°)
Optimization Test #3C (90 cfm to INJ1, INJ2 & INJ3 for 15 minutes then shut down; ~79% N2, 10% H2 & LPG, 1% CO2)									
3/7/2008	1306	Start Pulse							
3/7/2008	1321	End Pulse							
3/7/2008	1347	9.1	0.1	0.28	0.01		73	22.9	1016
3/10/2008	1105	9.9	0.16	0.32	0.005		65.5	16.8	1016
Optimization Test #4 (2, 45-minutes pulses; daily 15-minutes pulses w/30cfh constant flow)									
Optimization Test #5 (20 cfm to INJ2 for 125 minutes while maintaing 30 cfh the rest of the time; ~80% N2, 10% H2 & LPG)									
Optimization Test #6 (50 cfh to P4-18 & P4-28; ~80% N2, 10% H2 & LPG)									
3/20/2008	1330	Start Test							
3/26/2008	959	7.8	0.24	1.74	0.010		79.6	11.2	1017
3/28/2008	956	8.3	0.26	1.3	0.005		70.8	10.7	1009
3/31/2008	959	10.0	0.22	1.58	0.005		81.4	10.2	1013
4/2/2008	1055	8.0	0.18	3.5	1.8		74.5	15.7	1008
Optimization Test #7 (20 cfh to P4-18, --28, -38 (60 cfh total); ~80% N2, 10% H2 & LPG)									
4/2/2008	1233	Start Test							
4/4/2008	940	7.9	0.12	3.5	1.1		69.3	13.0	1013
4/7/2008	1410	7.3	0.18	6.5	2.7		80.6	18.7	1011

Aerojet GEDIT - Injection Test Input

Phase II Piezometer Monitoring Data

Well ID P8

Depth 28

Date	Time	Well or Injection Gas Sample						Well	Ambient Air	
		O ₂ (%)	CO ₂ (%)	Propane (%)	H ₂ (%)	He (ppm)	RH (%)	Pressure (in wc)	Temperature (C°)	Barometric pressure (mbar)
Optimization Test #7B (30 cfh to P4-18, & P4-28 (60 cfh total); ~80% N2, 10% H2 & LPG)										
4/7/2008	1458	Start Test								
4/9/2008	1105		12.3	0.10	2.5	1.4		80.0	15.4	1009
Optimization Test #7C (50 cfh to P4-18, & P4-28 (100 cfh total); ~79% N2, 10% H2 & LPG, 1% CO2)										
4/10/2009	1121	Start Test								
4/11/2008	1235		12.7	0.20	2.0	0.8		72.8	22	1013
4/16/2008	1030		12.9	0.22	2.0	0.1		59.1	15.8	1011
4/22/2008	1052		4.6	0.22	4.5	1.8		86.5	19.8	1009
4/25/2008	1001		7.5	0.14	4.0	0.10		49.9	22.3	1015
4/29/2008	1111		2.0	0.20	7.5	1.7		67.1	24.1	1007
5/5/2008	1315		2.3	0.16	7.0	1.9		55.1	35.0	1001
5/13/2008	935		3.9	0.18	7.0	0.10		25.3	34.2	1007
5/20/2008	936		9.0	0.34	4.0	1.2		56.5	24.0	1004
5/23/2008	1521		10.2	0.28	3.5	0.10		35.2	30.0	990
5/27/2008	907		5.5	0.44	7.0	2.0		47.5	16.9	1007
6/4/2008	909		1.3	0.38	9.0	2.0		41.4	25.6	1002
6/12/2008	1158		9.2	0.34	4.0	0.1		31.4	41.3	1003
6/20/2008	1025		0.5	0.34	8.5	1.8		32.5	40.8	1006
6/25/2008	1049		0.5	0.36	8.5	2.7		44.8	32.7	1005
7/2/2008	1147		0.7	0.48	8.5	2.6		72.4	30.4	1004
7/7/2008	1137		0.1	0.38	9.0	1.8		58.6	36.2	998

Aerojet GEDIT - Injection Test Input

Phase II Piezometer Monitoring Data

Well ID P8

Depth 28

Date	Time	Well or Injection Gas Sample						Well	Ambient Air	
		O ₂ (%)	CO ₂ (%)	Propane (%)	H ₂ (%)	He (ppm)	RH (%)	Pressure (in wc)	Temperature (C°)	Barometric pressure (mbar)
7/18/2008	1102	0.1	0.46	8.5	2.3		94.6		25.6	
7/24/2008	1101	0.4	0.40	8.5	2.300		62.0		28.5	1005
7/31/2008	1059	0.0	0.38	9.0	2.300		68.5		27.3	1003
8/7/2008	934	0.0	0.36	9.0	2.2		49.5		24.4	1004
8/12/2008	1036	0.0	0.40	9.0	1.9		64.8		28.3	1002
Optimization Test #8 (100 cfh of 100% Propane to P4-18, & P4-28 (50 cfh to each point)										
9/8/2008	0905 Test Start									
9/8/2008	1047	11.9	0.56	2.0	0.005					999
9/15/2008	927	11.0	0.64	2.5	0.005		34.7		26.5	1007
9/29/2008	951	1.2	1.76	30	0.005		44.3		22.5	1006
10/13/2008	1206	17.7	0.76	0.38	0.005		22.9		32.0	1017
10/20/2008	1134	16.1	0.84	1.06	0.005		47.2		26.8	1013
11/5/2008	1409	18.2	0.90	0.46	0.005		76.5		18.8	1016
11/17/2008	1121	17.0	0.86	0.70	0.005		66.3		27.0	1014
12/1/2008	1121	17.7	0.82	0.58	0.005		55.9		24.8	1013

Aerojet GEDIT - Injection Test Input

Phase II Piezometer Monitoring Data

Well ID P8

Depth 38

Date	Time	Well or Injection Gas Sample						Well	Ambient Air	
		O ₂ (%)	CO ₂ (%)	Propane (%)	H ₂ (%)	He (ppm)	RH (%)	Pressure (in wc)	Temperature (C°)	Barometric pressure (mbar)
12/12/2007	1143	19.2	0.56	0	0.002	100,000	76.4	0.02	10.9	1020
12/12/2007	1541							0.04		
12/13/2007	1033	20.2	0	0	0.22		62.3		12.9	1016
12/13/2007	1200	Discovered leak in O2 - all O2 data for 12/13/07 before 1200 invalid								
12/13/2007	1354	19.0	0.62	0	0.022		74.8		13.9	1013
12/14/2007	900	18.7	0.6	0	0.46		70.8	0.02	6.5	1017
12/21/2007	1240	18.9	1.04	0	0.22		86.1	0.05	10.6	1012
12/26/2006	1254	18.7	1.04	0	0.022		80.1	0	11.2	1016
12/27/2007	1055	18.9	1.2	0	0.22		81.4	0.03	6.5	1018
12/27/2007	1343	18.7	0.98	0	0.22		80.9		9	1016
12/27/2007	1507	18.8	1	0	0.22		85.9	0.04	8.5	1017
1/2/2008	1108	18.9	1.14	0	0.22		63.7	0.02	13.3	1012

Tracer Test #1 (10 cfm to INJ2, ~7% H2)										
1/21/2008	1046 Test start									
1/21/2008	1226	18.9	0.92	0	0.005		72.7	0.01	10.4	1007
1/21/2008	1326	18.8	0.90	0	0.022		77.6		11.2	1006
1/21/2008	1556	18.8	0.88	0	0.022		74.4	0.04	10.0	1006
1/22/2008	1030	18.9	1.02	0	0.022		77.6	0.03	6.3	1011
1/22/2008	1423	18.7	0.88	0	0.022		79.7		8.5	1009

Aerojet GEDIT - Injection Test Input

Phase II Piezometer Monitoring Data

Well ID P8

Depth 38

Date	Time	Well or Injection Gas Sample							Well	Ambient Air
		O ₂ (%)	CO ₂ (%)	Propane (%)	H ₂ (%)	He (ppm)	RH (%)	Pressure (in wc)	Temperature (C°)	Barometric pressure (mbar)
1/23/2008	1039	18.9	1.02	0	0.10		84.8	0.01	7.6	1008
1/23/2008	1133*	18.7								

Tracer Test #2 (20 cfm to INJ2, ~8% H2)										
1/18/2008	1120	Test start								
1/18/2008	1252	18.6	0.76	0	0.022		65.7		14.1	1014
1/18/2008	1406	18.7	0.84	0	0.010		64.8		15.9	1014
1/18/2008	1544	18.5	0.84	0	0.022		41.9	0.03	24.8	1014
1/19/2008	1035	18.8	1.02	0	0.022		59.9	0.01	10.1	1019
1/19/2008	1203*	18.5	1.16	0	0.022		62.7		15.6	1018

Tracer Test #3 (30 cfm to INJ2, ~4% H2)										
1/30/2008	1036	Test start								
1/30/2008	1126	16.5	1.18	0	0.046		90.7	0.06	9.9	1020
1/30/2008	1235	16.4	1.20	0	0.046		83.8		11.0	1019
1/30/2008	1443	16.3	1.16	0	0.10		77.0	0.04	15.0	1018
1/31/2008	1003	15.9	1.18	0	0.10		85.3	0.05	9.3	1019
1/31/2008	1140	15.9	1.22	0	0.10		83.6		9.6	1018
1/31/2008	1402	15.8	1.22	0	0.10		80.9	0.05	8.7	1016
1/31/2008	1435									
1/31/2008	1525	15.8	1.24	0	0.10		82.5	0.05	8.4	1014

Aerojet GEDIT - Injection Test Input

Phase II Piezometer Monitoring Data

Well ID P8

Depth 38

Date	Time	Well or Injection Gas Sample						Well	Ambient Air	
		O ₂ (%)	CO ₂ (%)	Propane (%)	H ₂ (%)	He (ppm)	RH (%)	Pressure (in wc)	Temperature (C°)	Barometric pressure (mbar)
Tracer Test #4 (60 cfm to INJ2, ~7% H2)										
1/28/2008	1236	Test start								
1/28/2008	1333	17.2	1.34	0	0.046			89.0	11.8	1010
1/28/2008	1433	17.1	1.38	0	0.005			82.6	12.7	1011
1/28/2008	1609	17.2	1.32	0	0.010			78.3	10.5	1012
1/29/2008	814	16.9	1.38	0	0.022			83.0	5.1	1017
1/29/2008	Final O2*		16.9							
Tracer Test #5 (90 cfm to INJ2, ~3% H2)										
2/5/2008	1015	Test start								
2/5/2008	1047	14.2	0.82	0	0.010			62.3	10.5	1019
2/5/2008	1147	14.2	0.80	0	0.010			73.9	11.1	1019
2/5/2008	1354	14.1	0.78	0	0.002			79.3	12.7	1018
2/5/2008	1517	14.4	0.88	0	0.022			55.2	21.4	1019
2/5/2008	1601	14.3	0.86	0	0.022			62.6	19.3	1018
Tracer Test #6 (30 cfm total; 10 cfm to each INJ1, 2, and 3; ~8% H2)										
2/7/2008	1500	Test start								
2/7/2008	1543	13.7	0.96	0	0.010			63.7	21.8	1016
2/7/2008	1631	13.6	0.94	0	0.022			59.6	20.0	1016
2/8/2008	1024	13.3	0.88	0	0.022			69.5	10.0	1017

Aerojet GEDIT - Injection Test Input

Phase II Piezometer Monitoring Data

Well ID P8

Depth 38

Date	Time	Well or Injection Gas Sample						Well	Ambient Air	
		O ₂ (%)	CO ₂ (%)	Propane (%)	H ₂ (%)	He (ppm)	RH (%)	Pressure (in wc)	Temperature (C°)	Barometric pressure (mbar)
Tracer Test #7 (60 cfm total; 20 cfm to each INJ1, 2, and 3, ~5% H2)										
1/17/2008	900 Test start									
1/17/2008	1054	18.6	0.56	0	0.22		65.7	0.02	8.8	1015
1/17/2008	1414	19.1	1.00	0	0.022		65.8		13.5	1013
1/17/2008	1546	18.9	0.96	0	0.22		45.4	0.03	19.3	1012
Tracer Test #8 (90 cfm total; 30 cfm each to INJ1, 2, and 3; ~4.5% H2)										
2/6/2008	1000 Test start									
2/6/2008	1051	13.9	0.84	0	0.010		83.1	0.05	11.0	1020
2/6/2008	1201	13.8	0.76	0	0.010		80.0		13.2	1020
2/6/2008	1256	13.8	0.72	0	0.010		80.2		14.4	1019
2/6/2008	1450	13.7	0.76	0	0.022		81.1	0.06	16.1	1017
2/6/2008	1547	13.6	0.74	0	0.022		66.2		19.5	1017
Optimization Test #1 (90 cfm to INJ2 for 4 hours then shut down; ~88% N2, 10% H2, 1% CO2 & LPG)										
2/20/2008	1146	13.9	1.04	0	0.022		74.9		15.5	1010
2/20/2008	1206 Test start									
2/20/2008	1558	13.6	0.92	0	0.022		56.4		23.6	1008
2/20/2008	1606 Test End									
2/20/2008	1642	13.4	0.90	0	0.022		58.8		21.2	1008
2/21/2008	936	13.9	1.02	0	0.022		75.6		10.4	1005
2/22/2008	1057	14.1	1.02	0	0.022		82.6		10.4	1003

Aerojet GEDIT - Injection Test Input

Phase II Piezometer Monitoring Data

Well ID P8

Depth 38

Date	Time	Well or Injection Gas Sample						Well	Ambient Air
		O ₂ (%)	CO ₂ (%)	Propane (%)	H ₂ (%)	He (ppm)	RH (%)	Pressure (in wc)	Temperature (C°)
Optimization Test #2 (30 cfm to INJ2 for 12 hours then shut down; ~88% N2, 10% H2, 1% CO2 & LPG)									
2/25/2008	1845 Test Start								
2/26/2008	653 Test End								
2/26/2008	720	14.7	1.08	0.08	0.01		87.5	4	1017
2/27/2008	1549	13.8	0.92	0	0.005		34.3	39.1	1009
2/28/2008	1112	14.2	0.72	0	0.022		69.3	16.9	1007
Optimization Test #3A (1 cfm to INJ2; ~88% N2, 10% H2, 1% CO2 & LPG)									
2/29/2008	1319 Test Start								
2/29/2008	1450	14.2	0.72	0	0.005		58.7	30.2	1009
3/3/2008	1104	14.5	0.82	0	0.005		62.1	16	1019
3/3/2008	1130 Test End								
Optimization Test #3B (1 cfm to INJ1, INJ2 & INJ3; ~88% N2, 10% H2, 1% CO2 & LPG)									
3/3/2008	1130 Test Start								
3/4/2008	946	14.5	0.9	0	0.01		65.7	13.8	1013
3/7/2008	1120	14.3	0.74	0	0.005		68.7	19.6	1018
3/7/2008	1306 Test End								
Optimization Test #3C (90 cfm to INJ1, INJ2 & INJ3 for 15 minutes then shut down; ~79% N2, 10% H2 & LPG, 1% CO2)									
3/7/2008	1306 Start Pulse								
3/7/2008	1321 End Pulse								
3/7/2008	1348	14.2	0.66	0	0.005		71.9	23	1016
3/10/2008	1107	14.5	0.8	0	0.005		67.8	16.9	1016

Aerojet GEDIT - Injection Test Input

Phase II Piezometer Monitoring Data

Well ID P8

Depth 38

Date	Time	Well or Injection Gas Sample						Well	Ambient Air
		O ₂ (%)	CO ₂ (%)	Propane (%)	H ₂ (%)	He (ppm)	RH (%)	Pressure (in wc)	Temperature (C°)
Optimization Test #4 (2, 45-minutes pulses; daily 15-minutes pulses w/30cfh constant flow)									
Optimization Test #5 (20 cfm to INJ2 for 125 minutes while maintaing 30 cfh the rest of the time; ~80% N2, 10% H2 & LPG)									
Optimization Test #6 (50 cfh to P4-18 & P4-28; ~80% N2, 10% H2 & LPG)									
3/20/2008	1330 Start Test								
3/26/2008	1000	13.8	0.92	0.24	0.010		77.9	11.2	1017
3/31/2008	1000	13.3	0.88	0.46	0.010		79.9	10.2	1013
4/2/2008	1057	13.2	0.90	0.52	0.046		77.8	15.8	1008
Optimization Test #7 (20 cfh to P4-18, --28, -38 (60 cfh total); ~80% N2, 10% H2 & LPG)									
4/2/2008	1233 Start Test								
4/4/2008	942	11.8	0.86	0.94	0.046		65.9	13.0	1013
4/7/2008	1411	10.3	0.88	2.0	0.22		81.1	18.8	1011
Optimization Test #7B (30 cfh to P4-18, & P4-28 (60 cfh total); ~80% N2, 10% H2 & LPG)									
4/7/2008	1458 Start Test								
4/9/2008	1107	9.5	0.82	9.4	0.022		81.2	15.4	1009
Optimization Test #7C (50 cfh to P4-18, & P4-28 (100 cfh total); ~79% N2, 10% H2 & LPG, 1% CO2)									
4/10/2009	1121 Start Test								
4/16/2008	1031	8.8	0.92	3.5	0.046		57.1	15.9	1011
4/22/2008	1054	9.2	0.94	3.5	0.046		88.2	19.9	1009
4/25/2008	1002	9.2	0.80	3.0	0.046		48.5	22.6	1015
4/29/2008	1112	9.2	0.90	3.5	0.046		65.1	23.8	1007

Aerojet GEDIT - Injection Test Input

Phase II Piezometer Monitoring Data

Well ID P8

Depth 38

Date	Time	Well or Injection Gas Sample						Well	Ambient Air	
		O ₂ (%)	CO ₂ (%)	Propane (%)	H ₂ (%)	He (ppm)	RH (%)	Pressure (in wc)	Temperature (C°)	Barometric pressure (mbar)
5/5/2008	1316	8.2	0.90	3.5	0.022		54.9		35.4	1001
5/13/2008	937	7.5	0.94	4.0	0.022		24.6		34.2	1007
5/20/2008	937	6.7	0.98	4.5	0.046		52.1		25.6	1004
5/23/2008	1522	6.4	0.60	4.0	0.046		26.4		29.9	990
5/27/2008	908	6.8	1.16	4.5	0.046		46.3		17.0	1007
6/4/2008	910	6.2	0.66	4.5	0.046		41.1		25.8	1002
6/12/2008	1202	6.0	1.02	4.5	0.010		29.3		42.0	1003
6/20/2008	1025	4.9	1.02	5.0	0.005		32.4		42.0	1005
6/25/2008	1050	4.5	1.02	5.0	0.046		45.3		32.8	1005
7/2/2008	1152	4.1	1.04	5.0	0.010		73.4		30.3	1004
7/7/2008	1138	3.8	0.94	5.0	0.022		58.5		36.1	998
7/18/2008	1103	3	1.12	5.5	0.046		93.6		25.6	
7/24/2008	1102	2.6	1.10	5.5	0.010		71.5		28.6	1005
7/31/2008	1100	2.2	1.18	5.5	0.046		63.9		27.3	1003
8/7/2008	935	1.9	1.22	6.5	0.046		47.6		24.2	1004
8/12/2008	1038	1.7	1.18	6.0	0.046		61.8		28.3	1002
Optimization Test #8 (100 cfh of 100% Propane to P4-18, & P4-28 (50 cfh to each point))										
9/8/2008	0905 Test Start									
9/8/2008	1049	1.3	1.26	6.5	0.010					999
9/15/2008	928	1.3	1.44	13.0	0.022		34.5		26.8	1007
9/29/2008	Did not measure									1006
10/13/2008	1208	0.8	1.82	30	0.010		20.6		32.5	1017
10/20/2008	1135	0.9	1.94	30	0.005		45.2		26.8	1013

Aerojet GEDIT - Injection Test Input

Phase II Piezometer Monitoring Data

Well ID P8

Depth 38

Date	Time	Well or Injection Gas Sample							Well	Ambient Air
		O ₂ (%)	CO ₂ (%)	Propane (%)	H ₂ (%)	He (ppm)	RH (%)	Pressure (in wc)	Temperature (C°)	Barometric pressure (mbar)
11/5/2008	1411	0.9	2.18	30	0.005		75.1		18.9	1016
11/17/2008	1122	0.5	2.16	30	0.010		70.9		27.0	1014
12/1/2008	1122	1.0	2.16	30	0.002		54.8		24.8	1013

Aerojet GEDIT - Injection Test Input

Phase II Piezometer Monitoring Data

Well ID P8

Depth 48

Date	Time	Well or Injection Gas Sample						Well	Ambient Air		
		O ₂ (%)	CO ₂ (%)	Propane (%)	H ₂ (%)	He (ppm)	RH (%)	Pressure (in wc)	Temperature (C°)	Barometric pressure (mbar)	
12/12/2007	1145	18.9	0.00	0	0.002	90,000	83.0	-0.05	11.0	1020	
12/12/2007	1541							0.04			
12/13/2007	1035	20.1	0	0	0.22		67.4		12.5	1016	
12/13/2007	1200	Discovered leak in O2 - all O2 data for 12/13/07 before 1200 invalid									
12/13/2007	1356	18.7	0	0	0.022		88.2		19.7	1013	
12/14/2007	901	18.6	0.04	0	0.46		75.6	0.0	6.5	1017	
12/21/2007	1245	18.4	0.20	0	0.22		87.5	0.03	11.3	1012	
12/26/2007	1257	18.3	0.18	0	0.022		87	0	11	1016	
12/27/2007	1057	18.3	0.2	0	0.22		80.8	0.04	6.5	1018	
12/27/2007	1344	18.1	0	0	0.022		81.4		9	1016	
12/27/2007	1509	18.5	0.1	0	0.022		86.2	0.02	8.5	1017	
1/2/2008	1110	18.1	0.22	0	0.22		79.9	0.02	13.4	1012	

Tracer Test #1 (10 cfm to INJ2, ~7% H2)										
1/21/2008	1046	Test start								
1/21/2008	1229	18.2	0.28	0	0.022		73.0	0.01	10.3	1007
1/21/2008	1328	18.4	0.28	0	0.022		75.0		11.3	1006
1/21/2008	1557	18.4	0.26	0	0.022		73.8	0.02	10.0	1006
1/22/2008	1031	18.2	0.40	0	0.022		77.3	0.03	6.3	1011
1/22/2008	1424	18.1	0.36	0	0.022		78.6		8.5	1009
1/23/2008	1040	17.7	0.36	0	0.10		84.3	0.02	7.5	1008
1/23/2008	1134*									

Aerojet GEDIT - Injection Test Input

Phase II Piezometer Monitoring Data

Well ID P8

Depth 48

Date	Time	Well or Injection Gas Sample						Well	Ambient Air
		O ₂ (%)	CO ₂ (%)	Propane (%)	H ₂ (%)	He (ppm)	RH (%)	Pressure (in wc)	Temperature (C°)

Tracer Test #2 (20 cfm to INJ2, ~8% H2)										
1/18/2008	1120 Test start									
1/18/2008	1254	18.2	0	0	0.022		64.6		14.0	1014
1/18/2008	1408	18.7	0.26	0	0.046		63.0		15.9	1014
1/18/2008	1546	18.6	0.30	0	0.046		41.1	0.04	25.0	1014
1/19/2008	1036	18.6	0.40	0	0.046		58.8	0.02	10.1	1019
1/19/2008	1204*	18.4	0.24	0	0.046		68.3		16.5	1017

Tracer Test #3 (30 cfm to INJ2, ~4% H2)										
1/30/2008	1036 Test start									
1/30/2008	1127	12.3	0.44	0	0.77		90.7	0.07	9.9	1020
1/30/2008	1237	12.3	0.50	0	0.94		84.1		11.0	1019
1/30/2008	1445	12.0	0.48	0	0.94		79.7	0.05	15.0	1018
1/31/2008	1142	10.4	0.50	0	0.10		83.7	0.06	9.6	1018
1/31/2008	1403	10.3	0.52	0	0.10		81.2	0.06	8.7	1016
1/31/2008	1435									
1/31/2008	1526	10.3	0.48	0	0.10		82.8	0.06	8.4	1014

Tracer Test #4 (60 cfm to INJ2, ~7% H2)										
1/28/2008	1236 Test start									
1/28/2008	1336	14.9	0.66	0	0.005		86.4		12.1	1010

Aerojet GEDIT - Injection Test Input

Phase II Piezometer Monitoring Data

Well ID P8

Depth 48

Date	Time	Well or Injection Gas Sample						Well	Ambient Air	
		O ₂ (%)	CO ₂ (%)	Propane (%)	H ₂ (%)	He (ppm)	RH (%)	Pressure (in wc)	Temperature (C°)	Barometric pressure (mbar)
1/28/2008	1434	14.8	0.54	0	0.002		82.5	0.06	12.8	1011
1/28/2008	1613	15.1	0.70	0	0.002		78.4	0.04	10.1	1012
1/29/2008	816	14.5	0.66	0	0.046		83.9	0.01	5.1	1017
1/29/2008	1016*	14.8			0.50					

Tracer Test #5 (90 cfm to INJ2, ~3% H2)										
2/5/2008	1015 Test start									
2/5/2008	1050	10.8	0.46	0	0.005		62.8	0.06	10.6	1019
2/5/2008	1148	10.8	0.42	0	0.002		71.2		11.2	1019
2/5/2008	1355	10.7	0.44	0	0.002		79.4	0.06	12.7	1018
2/5/2008	1518	10.9	0.42	0	0.002		54.8		21.8	1019
2/5/2008	1601	10.9	0.36	0	0.005		63.9		19.5	1018

Tracer Test #6 (30 cfm total; 10 cfm to each INJ1, 2, and 3; ~8% H2)										
2/7/2008	1500 Test start									
2/7/2008	1544	9.3	0.46	0	0.022		62.5		22.0	1016
2/7/2008	1632	9.4	0.44	0	0.005		59.3		20.1	1016
2/8/2008	1025	8.7	0.42	0	0.022		69.6		10.0	1017

Tracer Test #7 (60 cfm total; 20 cfm to each INJ1, 2, and 3, ~5% H2)										
1/17/2008	900 Test start									
1/17/2008	1057	18.4	0.12	0	0.22		64.3	0.02	8.7	1015

Aerojet GEDIT - Injection Test Input

Phase II Piezometer Monitoring Data

Well ID P8

Depth 48

Date	Time	Well or Injection Gas Sample						Well	Ambient Air	
		O ₂ (%)	CO ₂ (%)	Propane (%)	H ₂ (%)	He (ppm)	RH (%)	Pressure (in wc)	Temperature (C°)	Barometric pressure (mbar)
1/17/2008	1419	19.2	0.40	0	0.002		64.9		13.8	1013
1/17/2008	1551	19.2	0.42	0	0.002		45.2	0.01	19.9	1012

Tracer Test #8 (90 cfm total; 30 cfm each to INJ1, 2, and 3; ~4.5% H2)										
2/6/2008	1000 Test start									
2/6/2008	1052	10.4	0.46	0	0.005		82.0	0.06	11.0	1020
2/6/2008	1202	10.4	0.46	0	0.005		79.3		13.3	1020
2/6/2008	1257	10.4	0.44	0	0.005		77.9		14.4	1019
2/6/2008	1451	10.3	0.40	0	0.005		80.6	0.09	16.0	1017
2/6/2008	1548	10.2	0.38	0	0.005		66.6		19.3	1017

Optimization Test #1 (90 cfm to INJ2 for 4 hours then shut down; ~88% N2, 10% H2, 1% CO2 & LPG)										
2/20/2008	1148	12.8	0.64	0	0.022		75.1		15.5	1010
2/20/2008	1206 Test start									
2/20/2008	1559	12.5	0.54	0	0.01		54.9		23.5	1008
2/20/2008	1606 Test End									
2/20/2008	1643	12.5	0.52	0	0.022		58.1		21.1	1008
2/21/2008	938	12.8	0.62	0	0.022		74.9		10.5	1005
2/22/2008	1059	13	0.62	0	0.022		82.4		10.4	1003

Optimization Test #2 (30 cfm to INJ2 for 12 hours then shut down; ~88% N2, 10% H2, 1% CO2 & LPG)										
2/25/2008	1845 Test Start									

Aerojet GEDIT - Injection Test Input

Phase II Piezometer Monitoring Data

Well ID P8

Depth 48

Date	Time	Well or Injection Gas Sample						Well	Ambient Air
		O ₂ (%)	CO ₂ (%)	Propane (%)	H ₂ (%)	He (ppm)	RH (%)	Pressure (in wc)	Temperature (C°)
2/26/2008	653 Test End								
2/26/2008	722	13.6	0.86	0.1	0.022		86.7	4	1017
2/27/2008	1551	13.0	0.56	0	0.022		33.1	39.2	1009
2/28/2008	1126	13.2	0.26	0	0.01		73.8	16.8	1007
Optimization Test #3A (1 cfm to INJ2; ~88% N2, 10% H2, 1% CO2 & LPG)									
2/29/2008	1319 Test Start								
2/29/2008	1452	13.4	0.40	0.02	0.005		58.3	30.5	1009
3/3/2008	1106	13.6	0.42	0	0.005		60.8	16	1019
3/3/2008	1130 Test End								
Optimization Test #3B (1 cfm to INJ1, INJ2 & INJ3; ~88% N2, 10% H2, 1% CO2 & LPG)									
3/3/2008	1130 Test Start								
3/4/2008	947	13.9	0.44	0	0.005		63.7	13.9	1013
3/7/2008	1121	13.5	0.32	0.02	0.005		63.8	19.7	1018
3/7/2008	1306 Test End								
Optimization Test #3C (90 cfm to INJ1, INJ2 & INJ3 for 15 minutes then shut down; ~79% N2, 10% H2 & LPG, 1% CO2)									
3/7/2008	1306 Start Pulse								
3/7/2008	1321 End Pulse								
3/7/2008	1348	13.7	0.4	0	0.005		67.5	23.1	1016
3/10/2008	1108	13.7	0.46	0	0.005		66	16.9	1016

Aerojet GEDIT - Injection Test Input

Phase II Piezometer Monitoring Data

Well ID P8

Depth 48

		Well or Injection Gas Sample						Well	Ambient Air		
Date	Time	O ₂ (%)	CO ₂ (%)	Propane (%)	H ₂ (%)	He (ppm)	RH (%)	Pressure (in wc)	Temperature (C°)	Barometric pressure (mbar)	
Optimization Test #4 (2, 45-minutes pulses; daily 15-minutes pulses w/30cfh constant flow)											
Optimization Test #5 (20 cfm to INJ2 for 125 minutes while maintaing 30 cfh the rest of the time; ~80% N2, 10% H2 & LPG)											
3/26/2008	1002	Could not sample; insufficient flow									1013
Optimization Test #7 (20 cfh to P4-18, --28, -38 (60 cfh total); ~80% N2, 10% H2 & LPG)											
4/2/2008	1233	Start Test									
4/4/2008	943	Could not sample; insufficient flow									1013
4/7/2008	1412	Could not sample; insufficient flow									1011
Optimization Test #7B (30 cfh to P4-18, & P4-28 (60 cfh total); ~80% N2, 10% H2 & LPG)											
4/7/2008	1458	Start Test									
4/9/2008		Could not sample; insufficient flow									1009

Aerojet GEDIT - Injection Test Input

Phase II Piezometer Monitoring Data

Well ID P8

Depth 48

Date	Time	Well or Injection Gas Sample						Well	Ambient Air	
		O ₂ (%)	CO ₂ (%)	Propane (%)	H ₂ (%)	He (ppm)	RH (%)	Pressure (in wc)	Temperature (C°)	Barometric pressure (mbar)
Optimization Test #7C (50 cfh to P4-18, & P4-28 (100 cfh total); ~79% N2, 10% H2 & LPG, 1% CO2)										
4/10/2009	1121	Start Test								
4/16/2008	1032	Could not sample; insufficient flow								1011
4/22/2008	1058	Could not sample; insufficient flow								
4/25/2008	1003	Could not sample; insufficient flow								
4/29/2008	1113	Could not sample; insufficient flow								1007
5/5/2008	1318	Could not sample; insufficient flow								1001
5/13/2008	938	Could not sample; insufficient flow								1007
5/20/2008	938	Could not sample; insufficient flow								1004
5/23/2008	1523	Could not sample; insufficient flow								990
5/27/2008	910	Could not sample; insufficient flow								1007
6/4/2008	911	Could not sample; insufficient flow								1002
6/12/2008	1203	Could not sample; insufficient flow								1003
6/20/2008	1028	Could not sample; insufficient flow								1005
6/25/2008	1051	Could not sample; insufficient flow								1005
7/2/2008	1153	Could not sample; insufficient flow								1004
7/7/2008	1139	Could not sample; insufficient flow								998
7/18/2008	1105	Could not sample; insufficient flow								
7/24/2008	1105	Could not sample; insufficient flow								1005
7/31/2008	1102	Could not sample; insufficient flow								1003
8/7/2008	937	Could not sample; insufficient flow								1004

Aerojet GEDIT - Injection Test Input

Phase II Piezometer Monitoring Data

Well ID P8

Depth 48

Date	Time	Well or Injection Gas Sample						Well	Ambient Air
		O ₂ (%)	CO ₂ (%)	Propane (%)	H ₂ (%)	He (ppm)	RH (%)	Pressure (in wc)	Temperature (C°)
Optimization Test #8 (100 cfh of 100% Propane to P4-18, & P4-28 (50 cfh to each point)									
9/8/2008	0905	Test Start							
9/8/2008	1051	Could not sample; insufficient flow							999
9/15/2008	929	Could not sample; insufficient flow							1007
9/29/2008	929	Could not sample; insufficient flow							1006
10/13/2008	1209	Could not sample; insufficient flow							1017
10/20/2008	1136	Could not sample; insufficient flow							1013
11/5/2008	1412	Could not sample; insufficient flow							1016
11/17/2008	1123	Could not sample; insufficient flow							1014
12/1/2008	1123	Could not sample; insufficient flow							1013

Phase II Process Monitoring Data

Date	Time	Nitrogen			Hydrogen			LPG			CO ₂			Helium			CDM-INJ1			CDM-INJ2			CDM-INJ3		
		Pressure (psig)	Rotameter (cfm)	Flow (scfm)	Pressure (psig)	Rotameter (cfm)	Flow (scfm)	Pressure (psig)	Rotameter (cfh)	Flow (scfm)	Pressure (psig)	Rotameter (cfh)	Flow (scfm)	Pressure (psig)	Rotameter (cfm)	Flow (scfm)	Pressure (psig)	Rotameter (cfm)	Flow (scfm)	Pressure (psig)	Rotameter (cfm)	Flow (scfm)	Pressure (psig)	Rotameter (cfm)	Flow (scfm)
12/12/2007	1559	34	48	89	34	0	0.0	34	0	0.00	34	0	0.00	34	0	0.0	34	0	0	4	50	57.5	34	0	0
12/12/2007	1605	29	43	76	29	0	0.0	29	0	0.00	29	0	0.00	29	1.4	6.5	29	0	0	4	50	65.0	29	0	0
12/12/2007	1611	32	48	87	32	0	0.0	32	0	0.00	32	0	0.00	32	0	0.0	32	0	0	4	50	57.5	32	0	0
12/12/2007	1645	3	10	11	3	0	0.0	3	0	0.00	3	0	0.00	3	0	0.0	3	0	0	3	9.5	10.6	3	0	0
12/13/2007	845	27	44	76	27	0	0.0	27	0	0.00	27	0	0.00	27	0	0.0	27	0	0	4	50	57.5	27	0	0
12/13/2007	826	26	40	68	26	1.2	7.6	26	0	0.00	26	0	0.00	26	0	0.0	26	0	0	4	50	73.4	26	0	0
12/13/2007	1416	34.5	48	90	34.5	0	0.0	34.5	30	0.73	34.5	30	0.74	34.5	0	0.0	34.5	0	0	4	50	57.3	34.5	0	0
12/13/2007	1600	35	52	98	35	0	0.0	35	28	0.69	35	32	0.79	35	0	0.0	35	0	0	5	50	58.9	35	0	0
12/13/2007	1605		10	10	0	0	0.0	0	0	0.00	0	0	0.00	0	0	0.0		0	0			0.0		0	0
12/14/2007	930	52	10	22	52	0	0.0	52	0	0.00	52	0	0.00	52	0	0.0	52	0	0	1	8	8.4	52	0	0
12/26/2007	1347	44	5	10	44	0.25	1.9	44	0	0.00	44	0	0.00	44	0	0.0	0	0	0	0	10	14.6	0	0	0
12/26/2007	1347	Start test; Target = 9 cfm N2, 1 cfm H2																							
12/26/2007	1425	48	5	11	48	0.3	2.4	48	0	0.00	48	0	0.00	48	0	0.0	0	0	0	0	10	15.3	0	0	0
12/26/2007	1425	Increase H2 flow, Re-adjust to 0.25 on rotameter																							
12/27/2007	921	44	5	10	44	0.3	2.3	44	0	0.00	44	0	0.00	44	0	0.0	0	0	0	1.5	8	12.9	0	0	0
12/27/2007	922	44	5	10	44	0.3	2.3	44	0	0.00	44	0	0.00	44	0	0.0	0	0	0	1.5	10	16.1	0	0	0
12/27/2007	1635	Pat decides to shut off H2, decrease nitrogen to 5cfm over the weekend																							
12/27/2007	1645	57	5	11	57	0	0.0	57	0	0.00	57	0	0.00	57	0	0.0	0	0	0	2	5	5.4	3	0	0
1/2/2008	928	56	5	11	56	0	0.0	56	0	0.00	56	0	0.00	56	0	0.0	1	0	0	1	5.5	5.8	0	0	0
1/2/2008	929	Nitrogen Tank=12 inches H2O																							
1/2/2008	1148	53	5	11	53	0	0.0	53	0	0.00	53	0	0.00	53	0	0.0	0	0	0	0	4.5	4.6	0	0	0
1/2/2008	1256	0	0	0	0	0	0.0	0	0	0.00	0	0	0.00	0	0	0.0	0	0	#DIV/0!	0	0	#DIV/0!	0	0	#DIV/0!

Tracer Test #1 (10 cfm to INJ2, ~7 H2)																									
1/21/2008	729 (N2 Flush)	8	82	104	8.0	0	0.0	8	0	0.00	8	0	0.00	8	0	0.0	2	39	42.4	1.5	40	42.8	0.5	40	41.5
1/21/2008	1046 (test start)	2	8	8.7	2.0	0.2	0.81	2	0	0.00	2	0	0.00	2	0	0.0	3	0	0	1	10	13.0	0	0	0
1/21/2008	1625	2	8	8.7	2.0	0.2	0.81	2	0	0.00	2	0	0.00	2	0	0.0	2	0	0	1.5	10.5	13.9	0	0	0
1/22/2008	1432	2.5	8	8.8	2.5	0.2	0.82	2.5	0	0.00	2.5	0	0.00	2.5	0	0.0	3	0	0	2	10	13.4	0	0	0
1/23/2008	1228	2.5	8	8.8	2.5	0.2	0.82	2.5	0	0.00	2.5	0	0.00	2.5	0	0.0	2.5	0	0	1.5	10	13.2	0	0	0
1/23/2008	1229 (test end)	0	0	0.0	0	0	0.0	0	0	0.00	0	0	0.00	0	0	0.0	0	0	#DIV/0!	0	0	#DIV/0!	0	0	#DIV/0!

Tracer Test #2 (20 cfm to INJ2, ~8% H2)																									
1/18/2008	1120 (test start)	50.5	8	17	50.5	0.3	2.4	50.5	0	0.00	50.5	0	0.00	50.5	0	0.0	0	0	0	0	20	27.3	0	0	0
1/18/2008	1655	52	8	17	52	0.2	1.6	52	0	0.00	52	0	0.00	52	0	0.0	0.5	0	0	0.5	18.5	23.7	0	0	0
1/19/2008	838	52	8	17	52	0.2	1.6	52	0	0.00	52	0	0.00	52	0	0.0	2	0	0	1	17	22.1	0	0	0
1/19/2008	848	Notice pressure in 2nd H2 18-pack = 0 psi; open valve to 3rd H2 18-pack (close valve to 2nd 18-pack); adjust H2 rotameter to 7.9% H2 at INJ2 (@ 1050 am H2 = 5.8% at INJ2)																							

Phase II Process Monitoring Data

Date	Time	Nitrogen			Hydrogen			LPG			CO ₂			Helium			CDM-INJ1			CDM-INJ2			CDM-INJ3		
		Pressure (psig)	Rotameter (cfm)	Flow (scfm)	Pressure (psig)	Rotameter (cfm)	Flow (scfm)	Pressure (psig)	Rotameter (cfh)	Flow (scfm)	Pressure (psig)	Rotameter (cfh)	Flow (scfm)	Pressure (psig)	Rotameter (cfm)	Flow (scfm)	Pressure (psig)	Rotameter (cfm)	Flow (scfm)	Pressure (psig)	Rotameter (cfm)	Flow (scfm)	Pressure (psig)	Rotameter (cfm)	Flow (scfm)
1/19/2008	1215 (test end)	0	8	8	0	0	0.0	0	0	0.00	0	0	0.00	0	0	0.0	0	0	0	0	0	0	0	0	0
1/19/2008	1216 (N2 flush)	6.5	82	100	6.5	0	0.0	6.5	0	0.00	6.5	0	0.00	6.5	0	0.0	0	39	39.8	0	40	40.8	0	40	40.8
1/19/2008	1230 (end N2 flush)	0	0	0	0	0	0.0	0	0	0.00	0	0	0.00	0	0	0.0	0	0	#DIV/0!	0	0	#DIV/0!	0	0	#DIV/0!
Tracer Test #3 (30 cfm to INJ2, ~4%H2)																									
1/30/2008	854 (begin N2 flush)	8	82	104	8	0.00	0.0	8	0	0.00	8	0	0.00	8	0	0.0	3	39	43.7	1.5	40	42.8	0.5	40	41.48826
1/30/2008	Nitrogen tank = 36" Hydrogen 18-packs = 700, 200, 850 psi																								
1/30/2008	1011 (end N2 flush)	1.0	0	0	1	0.00	0.0	1	0	0.00	1	0	0.00	1	0	0.0	2	0	#DIV/0!	0.5	0	#DIV/0!	0	0	#DIV/0!
1/30/2008	1013 (no start test - NO GO)																								
1/30/2008	1020 (Can't get hydrogen to flow; Called pat and Praxair to reset pressure on N2 tank)																								
1/30/2008	1036 (test start)	16.0	17	25	16	0.30	1.7	16	0	0.00	16	0	0.00	16	0	0.0	2	0	0.0	0.5	30	36.4	0	0	0
1/30/2008	1402	16.0	17	25	16	0.30	1.7	16	0	0.00	16	0	0.00	16	0	0.0	0	0	0.0	0	30	35.8	0	0	0
1/30/2008	1528	16.0	17	25	16	0.30	1.7	16	0	0.00	16	0	0.00	16	0	0.0	0	0	0.0	0	30	35.8	0	0	0
1/30/2008	Nitrogen tank = ;Hydrogen 18-packs = 650, 100, 900 psi																								
1/31/2008	844	19.0	17	26	19	0.20	1.2	19	0	0.00	19	0	0.00	19	0	0.0	2.5	0	0.0	2	30	36.4	0	0	0
1/31/2008	Nitrogen tank = 23" ;Hydrogen 18-packs = 0, 0, 850 psi																								
1/31/2008	1332*	12.0	20	27	12	0.30	1.5	12	0	0.00	12	0	0.00	12	0	0.0	3	0	0.0	2	30	37.3	0.5	0	0
1/31/2008	1435 (test end)	2.0	0	0	2	0.00	0.0	2	0	0.00	2	0	0.00	2	0	0.0	2.5	0	#DIV/0!	1.5	0	#DIV/0!	0.5	0	#DIV/0!

Tracer Test #4 (60 cfm to INJ2)																									
1/28/2008	1029	Nitrogen tank = 35.5"			Hydrogen 18-pack = 2300 psi																				
1/28/2008	1236 (test start)	46	28	58	46	0.70	5.4	46	0	0.00	46	0	0.00	46	0	0.0	0.5	0	0.0	0.5	58*	#VALUE!	0	0	0
1/28/2008	1402	47	27	56	47	0.65	5.1	47	0	0.00	47	0	0.00	47	0	0.0	0	0	0.0	0.5	58*	#VALUE!	0	0	0
1/28/2008	1630	Nitrogen tank = 30.0"			Hydrogen 18-pack = 1700 psi																				
1/29/2008	730	54	27	60	54	0.65	5.4	54	0	0.00	54	0	0.00	54	0	0.0	2	0	0.0	2.5	58*	#VALUE!	0.5	0	0
1/29/2008	1019 (end test)	Nitrogen tank = 9.0"			Hydrogen 18-packs = 700, 200, 850 psi			Note - did not record final readings on control panel, just noted gas levels																	
1/29/2008	1020 (begin N2)	8	85	108	8	0	0.0	8	0	0.00	8	0	0.00	8	0	0.0	3.5	40	45.4	2.5	40	44.1	1.0	40	42.2
1/29/2008	1246 (end N2 flush)																								
Tracer Test #5 (90 cfm to INJ2, Target ~3% H2)																									
2/5/2008	953	Nitrogen tank = 54 psi, 36" Hydrogen =59 psi; 2200, 59 & 2200, 60, 2250																							
2/5/2008	1001	24	55	91	24	0.60	3.7	24	0	0.00	24	0	0.00	24	0	0.0	0	0	0.0	2.5	>50	#VALUE!	0	0	0
2/5/2008	1015 (test start)	4	70	Not sure if N2 flow is right; call Pat, restart; Test N2 to all 3 INJs																					
2/5/2008	1015 (test start)	22	50	81	22	0.65	3.9	22	0	0.00	22	0	0.00	22	0	0.0	0	0	0.0	2	>50	#VALUE!	0	0	0
2/5/2008	1618	22	48	77	22	0.65	3.9	22	0	0.00	22	0	0.00	22	0	0.0	0.5	0	0.0	3	>50	#VALUE!	0	0	0
		Nitrogen tank = 58 psi, 27"; Hydrogen = 55 & 2000, 55 & 1900, 55 & 2200																							

Phase II Process Monitoring Data

Date	Time	Nitrogen			Hydrogen			LPG			CO ₂			Helium			CDM-INJ1			CDM-INJ2			CDM-INJ3		
		Pressure (psig)	Rotameter (cfm)	Flow (scfm)	Pressure (psig)	Rotameter (cfm)	Flow (scfm)	Pressure (psig)	Rotameter (cfh)	Flow (scfm)	Pressure (psig)	Rotameter (cfh)	Flow (scfm)	Pressure (psig)	Rotameter (cfm)	Flow (scfm)	Pressure (psig)	Rotameter (cfm)	Flow (scfm)	Pressure (psig)	Rotameter (cfm)	Flow (scfm)	Pressure (psig)	Rotameter (cfm)	Flow (scfm)
2/5/2008	1635 (test end)	2	0	0	2	0	0.0	2	0	0.00	2	0	0.00	2	0	0.0	0.5	0	#DIV/0!	1.5	0	#DIV/0!	0	0	#DIV/0!
2/5/2008	1636 (N2 flushstart)	8	82	104	8	0	0.0	8	0	0.00	8	0	0.00	8	0	0.0	2	39	42.4	2	40	43.5	0.5	40	41.5
2/5/2008	1730 (end N2 flush)	0	0	0	0	0	0.0	0	0	0.00	0	0	0.00	0	0	0.0	0	0	#DIV/0!	0	0	#DIV/0!	0	0	#DIV/0!
Tracer Test #6 (30 cfm total, 10 cfm each to INJ1, 2, and 3; ~8% H2)																									
2/7/2008	839	Begin N2 flush; N2 trailer = 6"																							
2/7/2008	1016	End N2 flush; N2 trailer = 1", will resume flushing after Praxair refills tank																							
2/7/2008	1150	Resume N2 flush; at 1455 still have N2 at 1.5 - 1.8% at some points; decide to start test and run H2 at 7-8%																							
2/7/2008	1500 Test start	27	15	26	27	0.50	3.2	27	0	0.00	27	0	0.00	27	0	0.0	0	10	13.3	0	10	13.3	0	10.0	13.3
2/8/2008	836	30	14	25	30	0.55	3.7	30	0	0.00	30	0	0.00	30	0	0.0	2	10	14.7	1	10	14.2	0	9.0	12.4
	1103	26	15	25	26	0.55	3.5	26	0	0.00	26	0	0.00	26	0	0.0	0	10	13.6	0	10	13.6	0	10.0	13.6
	1104 End test	0	0	0	0	0.00	0.0	0	0	0.00	0	0	0.00	0	0	0.0	0	0	#DIV/0!	0	0	#DIV/0!	0	0.0	#DIV/0!
	1105	N2 trailer = 21" ; H2 18-packs = 650, 50, 2250 psi (~2250 psi = full 18-pack, 3600 cfm per 18-pack)																							

Tracer Test #7 (60 cfm total; 20 cfm to each INJ1, 2, and 3, ~5% H2)																									
1/17/2008	859	0	0	0	0	0	0.0	0	0	0.00	0	0	0.00	0	0	0.0	3	0	#DIV/0!	1	0	#DIV/0!	0	0	#DIV/0!
1/17/2008	900 (test start)	3	50	56	3	0.85	3.6	3	0	0.00	3	0	0.00	3	0	0.0	3	22	28.6	1	20	24.5	0	22	26.1
1/17/2008	1210	2.5	50	55	2.5	0.82	3.4	2.5	0	0.00	2.5	0	0.00	2.5	0	0.0	1	22	26.9	0.5	20	24.0	0	22	26.0
1/17/2008	1554	3	50	56	3	0.84	3.5	3	0	0.00	3	0	0.00	3	0	0.0	0.5	22	26.5	0.5	20	24.1	0	22	26.1
1/17/2008	1650 (end test)	3	50	56	3	0	0.0	3	0	0.00	3	0	0.00	3	0	0.0	0.5	22	22.8	0.5	20	20.7	0	22	22.4
1/17/2008	1651 (N2 flush)	8	80	101	8	0	0.0	8	0	0.00	8	0	0.00	8	0	0.0	2	36	39.1	1.5	38	40.7	0.5	38	39.4
1/17/2008	1750 (N2 flush)	60	0	0	0	0	0.0	0	0	0.00	0	0	0.00	0	0	0.0	0	0	0.0	0	0	0.0	0	0	0.0
1/18/2008	817 (N2 flush)	8	80	101	8	0	0.0	8	0	0.00	8	0	0.00	8	0	0.0	4	36	41.4	2.5	38	41.9	1.5	38	40.7
1/18/2008	1051 (begin test 2)	50	8	17	50	0	0.0	50	0	0.00	50	0	0.00	50	0	0.0	0	0	0	0	20	20.4	0	0	0.0

Tracer Test #8 (90 cfm total; 30 cfm each to INJ1, 2, and 3; ~4.5% H2)																									
2/6/2008	806	Begin N2 flush																							
2/6/2008	959	End N2 flush																							
2/6/2008	1000 Test Start	38	40	77	38	0.7	5.1	38	0	0.00	38	0	0.00	38	0	0.0	2	30	38.1	0.5	30	36.3	0	30	35.7
2/6/2008	1705	41	40	79	41	0.75	5.6	41	0	0.00	41	0	0.00	41	0	0.0	2	30	38.5	0.5	30	36.7	0	30	36.1
2/6/2008	1706 Test End	2	0	0	2	0	0.0	2	0	0.00	2	0	0.00	2	0	0.0	1.5	0	#DIV/0!	1	0	#DIV/0!	0	0	#DIV/0!

Optimization Test #1 (90 cfm to INJ2 for 4 hours, then shut down; 88% N2, 10% H2, 1% CO2, 1% LPG)																									
2/20/2008	1206 Test start	23	44	72	23	2.3	14.0	23	66	1.41	23	68	1.47	23	0	0.0	1.5	0	0.0	3.5	>50	#VALUE!	0	0	0.0
2/20/2008	1602	22	45	73	22	1.75	10.5	22	68	1.43	22	35	0.75	22	0	0.0	0	0	0.0	2.5	>50	#VALUE!	0	0	0.0
2/20/2008	1606 Test End	48	0	0	48	0	0.0	48	0	0.00	48	0	0.00	48	0	0.0	0	0	#DIV/0!	0	0	#DIV/0!	0	0	#DIV/0!

Phase II Process Monitoring Data

Date	Time	Nitrogen			Hydrogen			LPG			CO ₂			Helium			CDM-INJ1			CDM-INJ2			CDM-INJ3		
		Pressure (psig)	Rotameter (cfm)	Flow (scfm)	Pressure (psig)	Rotameter (cfm)	Flow (scfm)	Pressure (psig)	Rotameter (cfh)	Flow (scfm)	Pressure (psig)	Rotameter (cfh)	Flow (scfm)	Pressure (psig)	Rotameter (cfm)	Flow (scfm)	Pressure (psig)	Rotameter (cfm)	Flow (scfm)	Pressure (psig)	Rotameter (cfm)	Flow (scfm)	Pressure (psig)	Rotameter (cfm)	Flow (scfm)
Optimization Test #2 (30 cfm to INJ2 for 12 hours, then shut down; 88% N2, 10% H2, 1% CO2, 1% LPG)																									
2/25/2008	1845 Test start	5.5	23	28	5.5	0.6	2.7	5.5	22	0.34	5.5	22	0.35	5.5	0	0.0	2	0	0.0	2	30	40.2	0	0	0.0
2/26/2008	643	6	21	25	6	0.6	2.7	6	10	0.16	6	27	0.43	6	0	0.0	4	0	0.0	3	29	40.7	0.5	0	0.0
2/26/2008	653 Test End	54	0	0	54	0	0.0	54	0	0.00	54	0	0.00	54	0	0.0	4	0	#DIV/0!	2	0	#DIV/0!	0	0	#DIV/0!
Optimization Test #3A (1 cfm to INJ2; ~88% N2, 10% H2, 1% CO2 & LPG)																									
2/29/2008	1319 Test start	Total Flow = 60 cfm (N2 = 53, H2 = 6, CO2 & LPG = 0.6 cfm)																							
3/3/2008	1121	Total Flow = 57 cfm																							
3/3/2008	1130 Test End																								
Optimization Test #3B (1 cfm to INJ1, INJ2, & INJ3, ~0.33 cfm per well; ~88% N2, 10% H2, 1% CO2 & LPG)																									
3/3/2008	1130 Test start	Total Flow = 60 cfm to INJ1, INJ2 & INJ3 (approx. 0.33 cfm per well)																							
3/4/2008	1015	Total Flow = 56 cfm																							
3/7/2008	1030	Total Flow = 49 cfm																							
3/7/2008	1306 Test End	Total Flow = 0																							
Optimization Test #3C (90 cfm to INJ1, INJ2 & INJ3 for 15 minutes then shut down; ~79% N2, 10% H2 & LPG, 1% CO2)																									
3/7/2008	1306 StartPulse	4	60	69	4	2.4	10.3	4	240	3.61	4	67	1.02	4	0	0.0	0	29	39.2	0	30	40.5	0	30	40.5
3/7/2008	1321 EndPulse	60	0	0	60	0	0.0	60	0	0.00	60	0	0.00	60	0	0.0	2	0	#DIV/0!	2	0	#DIV/0!	0	0	#DIV/0!
Optimization Test #4 (30 cfm to INJ1, INJ2 & INJ3 (10 cfm each) for 45 minutes, then 30 cfm to INJ2 for 45 minutes; ~79% N2, 10% H2 & LPG, 1% CO2)																									
Followed by 15 minutes daily pulses at 30 cfm to INJ2 while maintaining ~30 cfm the rest of the time																									
3/10/2008	1217 StartPulse	0.5	21	22	0.5	0.85	3.3	0.5	>100	#VALUE!	0.5	22	0.30	0.5	0	0.0	0	10	#VALUE!	0	10	#VALUE!	0	10	#VALUE!
3/10/2008	1302	3	19	21	3	0.85	3.6	3	>100	#VALUE!	3	22	0.33	3	0	0.0	2	0	#VALUE!	2	30	#VALUE!	0	0	#VALUE!
3/10/2008	1347 Endpulse	Total flow = 30 cfm																							
3/11/2008	858	Total flow = 48 cfm																							
3/11/2008	950 Startpules	18	13	20	18	0.85	4.8	18	>100	#VALUE!	18	24	0.48	18	0	0.0	0	0	#VALUE!	0	30	#VALUE!	0	0	#VALUE!
3/11/2008	1005 Endpulse	Total flow = 30 cfm																							
3/12/2008	940	Total flow = 28 cfm																							
3/12/2008	1017 Startpules	22	13	21	22	0.8	4.8	22	>100	#VALUE!	22	22	0.47	22	0	0.0	0.5	0	#VALUE!	0.5	30	#VALUE!	0	0	#VALUE!
3/12/2008	1032 Endpulse	Total flow = 30 cfm																							
3/13/2008	900	Total flow = 23 cfm																							
3/13/2008	925 Startpules	6	13	16	6	0.8	3.6	6	>100	#VALUE!	6	22	0.35	6	0	0.0	1	0	#VALUE!	1	30	#VALUE!	0	0	#VALUE!
3/13/2008	940 Endpulse	Total flow = 30 cfm																							
3/14/2008	1120	Total flow = 41 cfm																							

Phase II Process Monitoring Data

Date	Time	Nitrogen			Hydrogen			LPG			CO ₂			Helium			CDM-INJ1			CDM-INJ2			CDM-INJ3		
		Pressure (psig)	Rotameter (cfm)	Flow (scfm)	Pressure (psig)	Rotameter (cfm)	Flow (scfm)	Pressure (psig)	Rotameter (cfh)	Flow (scfm)	Pressure (psig)	Rotameter (cfh)	Flow (scfm)	Pressure (psig)	Rotameter (cfm)	Flow (scfm)	Pressure (psig)	Rotameter (cfm)	Flow (scfm)	Pressure (psig)	Rotameter (cfm)	Flow (scfm)	Pressure (psig)	Rotameter (cfm)	Flow (scfm)
3/14/2008	1154 Startpules 1202	17	40	60	17	2.3	12.9	17	>100	#VALUE!	17	50	0.99	17	0	0.0	0.5	0	#VALUE!	2	>50	#VALUE!	0	0	#VALUE!
3/14/2008	Endpulse	Total flow = 30 cfm																							
3/15/2008	1105	Total flow = 52 cfm																							
3/15/2008	1156 Startpules 1204	17	40	60	17	2.35	13.1	17	>100	#VALUE!	17	66	1.31	17	0	0.0	0	0	#VALUE!	1.5	>50	#VALUE!	0	0	#VALUE!
3/15/2008	Endpulse	Total flow = 30 cfm																							
3/16/2008	1055	Total flow = 22 cfm																							
3/16/2008	1120 Startpules 1128	4	15	17	4	2.3	9.9	4	>100	#VALUE!	4	66	1.00	4	0	0.0	0	0	#VALUE!	0	30	#VALUE!	0	0	#VALUE!
3/16/2008	Endpulse	Total flow = 30 cfm																							
3/17/2008	907	Total flow = 14 cfm																							

Optimization Test #5 (20 cfm to INJ2 for 125 minutes while maintaing 30 cfh the rest of the time; ~80% N2, 10% H2 & LPG)																									
3/17/2008	1037 StartPulse 1242	5	11	13	5	0.6	2.6	5	>100	#VALUE!	5	0	0.00	5	0	0.0	0	0	#VALUE!	0	20	#VALUE!	0	0	#VALUE!
3/17/2008	Endpulse	Total flow = 30 cfm																							
3/18/2008	930	Total flow = 8 cfm																							
3/18/2008	931	Total flow = 36 cfm																							
3/19/2008	943	Total flow = 22 cfm																							
3/20/2008	927	Total flow = 19 cfm																							

Optimization Test #6 (50 cfh to P4-18 & P4-28; ~80% N2, 10% H2 & LPG)																									
3/20/2008	1330 Start Test	Total flow = 50 cfh																							
3/21/2008	945	Total flow = 50 cfh																							
3/24/2008	935	Total flow = 49 cfh																							
3/26/2008	910	Total flow = 50 cfh																							
3/26/2008	1055	Total flow = 57 cfh																							
3/28/2008	920	Total flow = 57 cfh																							
3/31/2008	1030	Total flow = 57 cfh																							
4/2/2008	920	Total flow = 57 cfh																							
4/2/2008	1233 (Test 7)	P4-18, -28, -38 = 20 cfh each (60cfh total)			Control Panel = 33 cfh, 34 psi																				

Optimization Test #7A (60 cfh to P4-18, -28, -38 (20 cfh each), 10% H2 & LPG)																									
4/2/2008	1233 (StartTest)	P4-18, -28, -38 = 20 cfh each (60cfh total)			Control Panel = 33 cfh, 34 psi																				
4/4/2008	913	P4-18 = 24 cfh, P4-28 = 23 cfh, P4-38 = 21 cfh			Control Panel = 39 cfh, 34 psi																				
4/4/2008	1005	O2 = 0.0% H2 = 6.9% LPG = 13.5%																							
4/4/2008	1006	Reset: P4-18, -28, -38 = 20 cfh each			H2 = 8.0% LPG = 10.5%																				
4/7/2008	1343	P4-18 = 20 cfh, P4-28 = 19 cfh, P4-38 = 20 cfh			Control Panel = 33 cfh, 34 psi																				
4/7/2008	1456	Control Panel = 57 cfh, 32 psi P4-18, -28, -38, -48 = 25, 25, 24, 24 cfh (98 cfh total)																							

Phase II Process Monitoring Data

Date	Time	Nitrogen			Hydrogen			LPG			CO ₂			Helium			CDM-INJ1			CDM-INJ2			CDM-INJ3		
		Pressure (psig)	Rotameter (cfm)	Flow (scfm)	Pressure (psig)	Rotameter (cfm)	Flow (scfm)	Pressure (psig)	Rotameter (cfh)	Flow (scfm)	Pressure (psig)	Rotameter (cfh)	Flow (scfm)	Pressure (psig)	Rotameter (cfm)	Flow (scfm)	Pressure (psig)	Rotameter (cfm)	Flow (scfm)	Pressure (psig)	Rotameter (cfm)	Flow (scfm)	Pressure (psig)	Rotameter (cfm)	Flow (scfm)
4/7/2008	1458 start test 7B	Set P4-18 & P4-28 = 30 cfh each (60 cfh total)																							

Optimization Test #7B (60 cfh to P4-18, & P4-28, (30 cfh each), 10% H2 & LPG)																								
4/7/2008	1458 start test 7B	Set P4-18 & P4-28 = 30 cfh each (60 cfh total)																						
4/9/2008	1016	Control Panel = 37 cfh, 34 psi			P4-18 = 33 cfh; P4-28 = 33 cfh																			
4/9/2008	1154	H2 = 1.8%; LPG = 1.74%; O2 = 0.0%																						
4/9/2008	1242	H2 = 8.4%; LPG = 9.5%; O2 = 0.0%; P4-18 = 30 cfh; P4-28 = 30 cfh																						
4/10/2008	1058	Control Panel = 35 cfh, 28 psi			P4-18 = 29 cfh; P4-28 = 29 cfh																			
4/10/2008	1121	Open up P4-18 & P4-28 all the way to >40 cfh each																						

Optimization Test #7C (100 cfh to P4-18, & P4-28, (50 cfh each), 10% H2 & LPG, 1% CO2)																								
4/10/2008	1311 start test	Control Panel = 55 cfh, 33 psi P4-18 = >40 cfh; P4-28 = >40 cfh																						
4/11/2008	1205	Control Panel = 54 cfh, 32 psi P4-18 = >40 cfh; P4-28 = >40 cfh																						
4/11/2008	1205	32.0	54	98.2																				
4/11/2008	1422	Propane tank filled, tank volume = 80%, 38 psi																						
4/11/2008	1515	P4-18 = >40 cfh; P4-28 = >40 cfh, H2 = 8.5%, LPG = 11.0%																						
4/11/2008	1516	Control Panel = 50 cfh, 26 psi																						
4/14/2008	940	Control Panel = 34 cfh, 11 psi			P4-18 = 20 cfh; P4-28 = 20 cfh			H2 = 15%, LPG = 26%			Propane tank = 63%, 38 psi													
4/14/2008	1154	Control Panel = 58 cfh, 35 psi			P4-18 = >40 cfh; P4-28 = >40 cfh			H2 = 9.7%, LPG = 10.5%, CO2 = 1.10%																
4/16/2008	1005	Control Panel = 57 cfh, 35 psi			P4-18 = >40 cfh; P4-28 = >40 cfh																			
4/16/2008	1050	H2 = 8.0%, LPG = 10.0%, CO2 = 0.36% Readjust rates to: H2 = 9.0%, LPG = 10.5%, CO2 = 0.86%																						
4/16/2008	1115	Connect "T" fittings at P4			P4-18 = 25 + 25 = 50 cfh; P4-28 = 25 + 24 = 49 cfh																			
4/16/2008	1125	Propane tank = 54%, 38 psi H2 18-packs = 0, 0, 900 psi (~2300 psi = full 18-pack)																						
4/17/2008	1000	Control Panel = 57 cfh, 35 psi			P4-18 = 50 cfh; P4-28 = 49 cfh																			
4/17/2008	1001	Begin Nitrogen flush in preparation for drilling																						
4/17/2008		3	60	67	3	0	0.0	3	0	0.00	3	0	0.00	3	0	0.0	26	26.5	27	27.5	27	27.5		
4/17/2008	1420	Stop Flushing																						
4/18/2008	1522	Propane Tank = 50% full, 38 psi, H2 = 800 psi, N2 = 37 psi																						
4/18/2008		CO2 leaking at 16 pack, will call Praxair																						
4/18/2008		Control Panel = 58 cfh, 34 psi			P4-18 = 48 cfh; P4-28 = 48 cfh																			
4/18/2008	1533	Injected %s --> CO2 = 0%, LPG = 10%, H2 = 8%, O2 = 0%																						
4/22/2008	930	Control Panel = 58 cfh, 34 psi; propane = 31% volume, 38 psi																						
4/22/2008	930	P4-18 = 48 cfh; P4-28 = 48 cfh; H2 = 0 psi (empty); N2 = 10"																						
4/22/2008	1056	Injected %s --> O2 = 0%, CO2 = 0%, LPG = 12.5%, H2 = 0.91%																						
4/22/2008	1104	Note - out of H2; call praxair for refill; adjust LPG to 10.5%																						
4/22/2008	1105	Open up "empty" H2 18-packs, injecting 1.0% H2																						

Phase II Process Monitoring Data

Date	Time	Nitrogen			Hydrogen			LPG			CO ₂			Helium			CDM-INJ1			CDM-INJ2			CDM-INJ3		
		Pressure (psig)	Rotameter (cfm)	Flow (scfm)	Pressure (psig)	Rotameter (cfm)	Flow (scfm)	Pressure (psig)	Rotameter (cfh)	Flow (scfm)	Pressure (psig)	Rotameter (cfh)	Flow (scfm)	Pressure (psig)	Rotameter (cfm)	Flow (scfm)	Pressure (psig)	Rotameter (cfm)	Flow (scfm)	Pressure (psig)	Rotameter (cfm)	Flow (scfm)	Pressure (psig)	Rotameter (cfm)	Flow (scfm)
4/23/2008	914	Injected %s --> O2 = 0%, CO2 = 0%, LPG = 9.5%, H2 =1.3%																							
4/23/2008	916	P4-18 = 49 cfh; P4-28 = 48 cfh; Contorl Panel = 58 cfh, 35 psi																							
4/23/2008		Propane = 26% volume, 38 psi; N2 = 36"																							
4/25/2008	900	Control Panel = 57 cfh; propane ~ 10.5%; 930 Adjust flow rates																							
4/25/2008	938	Control Panel = 58 cfh, 34 psi; H2 = 9.0%, LPG = 10.5%, CO2 = 0.76%, O2 = 0%																							
4/25/2008	938	P4-18 = 48 cfh, P4-28 = 47 cfh, N2 = 31", propane = 70% volume																							
4/25/2008		H2, N2, LPG = 37 psi, CO2 = 49 psi, H2 = full, 3-18 packs																							
4/25/2008	1030	Readjust to H2 = 10%, LPG = 10%, CO2 = 1.06%, O2 = 0%																							
4/29/2008	1047	P4-18 = 48 cfh, P4-28 = 47 cfh, N2 = 24", 37 psi; propane = 52% volume, 37 psi									H2 18-packs = 2300/38 psi; 1800/38 psi; 2300/39 psi														
4/29/2008	1048	Control Panel = 58 cfh, 34 psi; H2 = 8.6%, LPG = 10.0%, CO2 = 0.10%, O2 = 0%									CO2 = 740/46 psi														
4/29/2008	1145	Readjust to H2 = 10%, LPG = 10%, CO2 = 1.10%, O2 = 0%																							
5/5/2008	1336	P4-18 = 47 cfh, P4-28 = 47 cfh			Injected %s --> O2 = 0%, CO2 = 0.92%, LPG = 10.0%, H2 =6.8%																				
5/5/2008	1340	Control Panel = 57 cfh, 33 psi			propane = 80% volume, 38 psi						H2 18-packs = 2400/38 psi; 800/38 psi; 2400/38 psi						CO2 = 840/58 psi								
5/5/2008	1344	N2 = 12", 36 psi																							
5/5/2008	1350	Readjust to H2 = 9.5%, LPG = 9.5%, CO2 = 0.84%, O2 = 0%									P4-18 = 48 cfh, P4-28 = 47 cfh														
5/13/2008	837	Control Panel = 57 cfh, 34 psi			propane = 50% volume, 38 psi																				
5/13/2008	841	H2 18 packs = 2300/36psi; 0/35 psi; 2050/36 psi; CO2 = 80/68 psi																							
5/13/2008	843	N2 = 22", 36 psi																							
5/13/2008	856	P4-18 & 28 = 47 cfh;			Injected %s --> O2 = 0%, CO2 = 1.72%, LPG = 11.0%, H2 =1.2%																				
5/13/2008	1010	Change CO2 tank source: CO2 = 900/62 psi																							
5/13/2008	1040	Readjust to H2 = 10%, LPG = 9.5%, CO2 = 1.00%, O2 = 0%									P4-18 & 28 = 47 cfh														
5/20/2008	853	Control Panel = 57 cfh, 35 psi			propane = 60% volume, 38 psi																				
5/20/2008	855	H2 18 packs = 2300/36psi; 0/35 psi; 0/36 psi; CO2 = 660/58 psi																							
5/20/2008	858	N2 = 35", 37 psi																							
5/20/2008	909	P4-18 & 28 = 47 cfh;			Injected %s --> O2 = 0%, CO2 = 1.00%, LPG = 9.5%, H2 =4.2%																				
5/20/2008	1052	Readjust to H2 = 10%, LPG = 9.5%, CO2 = 0.94%, O2 = 0%									P4-18 & 28 = 47 cfh														
5/23/2008	842	Control Panel = 56 cfh, 35 psi			propane = 50% volume, 38 psi																				
5/23/2008	844	H2 18 packs = 2200/39psi; 0/38 psi; 0/38 psi; CO2 = 660/58 psi																							
5/23/2008	846	N2 = 30", 37 psi																							
5/23/2008	918	P4-18 & 28 = 47 cfh;			Injected %s --> O2 = 0%, CO2 = 1.02%, LPG = 10%, H2 =4.2%																				
5/23/2008	948	hooked up H2 6 pack to line: 1950/36 psi																							
5/23/2008	1032	readjust injection %'s: H2 = 9.8%, LPG = 9.5%, CO2 = 1.06%, O2 = 0.0%																							
5/23/2008	1336	readjust injection %'s: H2 = 10%, LPG = 9.5%, CO2 = 1.06%, O2 = 0.0%																							
5/23/2008	1450	Check injection %'s: H2 = 10%, LPG = 9.5%, CO2 = 1.02%, O2 = 0.0%																							
5/23/2008	1550	Check injection %'s: H2 = 9.4%, LPG = 9.0%, CO2 = 1.14%, O2 = 0.0%									P4-18 & 28 = 47 cfh														
5/27/2008	826	Control Panel = 57 cfh, 35 psi			propane = 30% volume, 37 psi																				
5/27/2008	828	H2 18 packs = 1500/40psi; H2 6 pack: 1800/40 psi; CO2 = 380/64 psi																							
5/27/2008	830	N2 = 22", 38 psi																							
5/27/2008	844	P4-18 & 28 = 47 cfh;			Injected %s --> O2 = 0%, CO2 = 2.48%, LPG = 11%, H2 =9.5%																				
5/27/2008	935	readjust injection %'s: H2 = 9.8%, LPG = 10%, CO2 = 0.98%, O2 = 0.0%																							
5/28/2008	900	Hook up 2 H2 18 packs: 2300/40 psi; 2300/40psi																							
5/28/2008	905	Check injection %'s: H2 = 9.9%, LPG = 10.5%, CO2 = 1.20%, O2 = 0.0%																							
6/4/2008	833	Control Panel = 57 cfh, 35 psi			propane = 50% volume, 38 psi																				

Phase II Process Monitoring Data

Date	Time	Nitrogen			Hydrogen			LPG			CO ₂			Helium			CDM-INJ1			CDM-INJ2			CDM-INJ3			
		Pressure (psig)	Rotameter (cfm)	Flow (scfm)	Pressure (psig)	Rotameter (cfm)	Flow (scfm)	Pressure (psig)	Rotameter (cfh)	Flow (scfm)	Pressure (psig)	Rotameter (cfh)	Flow (scfm)	Pressure (psig)	Rotameter (cfm)	Flow (scfm)	Pressure (psig)	Rotameter (cfm)	Flow (scfm)	Pressure (psig)	Rotameter (cfm)	Flow (scfm)	Pressure (psig)	Rotameter (cfm)	Flow (scfm)	
6/4/2008	835	H2 18 packs = 600/40psi; 2300/40 psi; CO2 = 20/46 psi																								
6/4/2008	837	N2 = 37", 37 psi																								
6/4/2008	846	P4-18 & 28 = 47 cfh;			Injected %s --> O2 = 0%, CO2 = 0%, LPG = 11%, H2 = 7.6%																					
6/4/2008	939	Change CO2 tank source: CO2 = 760/66 psi																								
6/4/2008	955	readjust injection %'s: H2 = 10%, LPG = 10.0%, CO2 = 1.02%, O2 = 0.0%																								
6/10/2008	841	Control Panel = 57 cfh, 34 psi			P4-18 & 28 = 48, 47 cfh;																					
6/10/2008	842	Stop test to drill confirmation borings 3 & 4																								
6/10/2008	1652	Restart test;			P4-18 & 28 = 48, 47 cfh;																					
6/10/2008	1652	Injected %s --> O2 = 0%, CO2 = 0.94%, LPG = 10%, H2 = 9.7%																								
6/12/2008	1231	P4-18 & 28 = 48, 46 cfh;			Injected %s --> O2 = 0%, CO2 = 0.80%, LPG = 10.5%, H2 = 0.0%																					
6/12/2008	1232	Control Panel = 56 cfh, 33 psi			propane = 20% volume, 37 psi			N2 = 21", 36 psi																		
6/12/2008	1232	H2 18 packs = 0/34psi; 2200/35 psi; 2450/35 psi; CO2 = 920/56 psi																								
6/12/2008	1305	Readjust Hydrogen 18-packs to 40 psi;																								
6/12/2008	1305	Injected %s --> O2 = 0%, CO2 = 1.06%, LPG = 9.5%, H2 = 9.4%						P4-18 & 28 = 47 chf																		
6/20/2008	1103	P4-18 & 28 = 47, 47 cfh;			Injected %s --> O2 = 0%, CO2 = 0.00%, LPG = 10.0%, H2 = 5.5%																					
6/20/2008	1103	Control Panel = 57 cfh, 32 psi			propane = 50% volume, 37.5 psi			N2 = 30", 35 psi																		
6/20/2008	1103	H2 18 packs = 0/30psi; 1100/38 psi; 2500/38 psi; CO2 = 0/46 psi																								
6/20/2008	1120	Open new CO2 cylinder. Adjust CO2 to 58 psi and H2 to 40 psi																								
6/20/2008	1220	Injected %s --> O2 = 0.0%, CO2 = 0.94%, LPG = 9.0%, H2 = 10.0%						P4-18 & 28 = 47 chf																		
6/25/2008	1010	Control Panel = 57 cfh, 34 psi			propane = 80% volume, 38 psi			N2 = 28"																		
6/25/2008	1010	H2 18 packs = 0/28psi; 1050/40 psi; 1400/40 psi; CO2 = 710/53 psi																								
6/25/2008	1110	P4-18 & 28 = 48, 47 cfh;			Injected %s --> O2 = 0%, CO2 = 1.08%, LPG = 10.0%, H2 = 10%																					
7/2/2008	1054	Control Panel = 56 cfh, 34 psi			propane = 50% volume, 38 psi			N2 = 35"																		
7/2/2008	1054	H2 18 packs = 0/24psi; 1050/41 psi; 0/40 psi; CO2 = 520/56 psi																								
7/2/2008	1054	P4-18 & 28 = 47, 47 cfh;																								
7/2/2008	1221	Injected %s --> O2 = 0%, CO2 = 1.62%, LPG = 10.5%, H2 = 10%																								
7/2/2008	1235	Turned CO2 down to 53 psi																								
7/2/2008	1235	Injected %s --> O2 = 0%, CO2 = 1.08%, LPG = 10.5%, H2 = 10%																								
7/2/2008	1235	P4-18 & 28 = 47, 47 cfh;																								
7/7/2008	1033	P4-18= 47 cfh			P4-28= 47 cfh																					
7/7/2008	1044	Three New H2 18-packs delivered and 6 new CO2 tanks delivered																								
7/7/2008	1044	Injected %s --> O2 = 0.0%, Propane = 10%, CO2 = 1.10%, H2 = 12%																								
7/7/2008	1044	Control Panel = 57 cfh, 33 psi																								
7/7/2008	1044	propane = 30% volume, 37 psi																								
7/7/2008	1044	H2 18 packs = off; off; 2400/41 psi																								
7/7/2008	1044	CO2 = >1000/52 psi																								
7/7/2008	1044	N2 = 26" / 36 psi																								
7/7/2008	1114	Turned all new H2 tanks and adjusted tank pressures																								
7/7/2008	1114	propane = 30% volume, 37 psi																								
7/7/2008	1114	H2 18 packs = 2400/41 psi; 2400/41 psi; 2400/41 psi																								
7/7/2008	1114	CO2 = >1000/53 psi																								
7/7/2008	1114	N2 = 26" / 36 psi																								
7/7/2008	1114	Injected %s --> O2 = 0.0%, Propane = 10%, CO2 = 1.00%, H2 = 11%																								

Phase II Process Monitoring Data

Date	Time	Nitrogen			Hydrogen			LPG			CO ₂			Helium			CDM-INJ1			CDM-INJ2			CDM-INJ3		
		Pressure (psig)	Rotameter (cfm)	Flow (scfm)	Pressure (psig)	Rotameter (cfm)	Flow (scfm)	Pressure (psig)	Rotameter (cfh)	Flow (scfm)	Pressure (psig)	Rotameter (cfh)	Flow (scfm)	Pressure (psig)	Rotameter (cfm)	Flow (scfm)	Pressure (psig)	Rotameter (cfm)	Flow (scfm)	Pressure (psig)	Rotameter (cfm)	Flow (scfm)	Pressure (psig)	Rotameter (cfm)	Flow (scfm)
7/11/2008	1051	Confirmation borings drilled yesterday																							
7/11/2008	1051	P4-18= 47 cfh			P4-28= 49 cfh																				
7/11/2008	1051	Injected %s --> O2 = 0.0%, Propane = 10%, CO2 = 1.42%, H2 = 13%																							
7/11/2008	1053	Control Panel = 58 cfh, 34 psi																							
7/11/2008	1053	propane = 16% volume, 37 psi																							
7/11/2008	1053	H2 18 packs = 2300/41 psi; 1650/41 psi; 2300/41 psi																							
7/11/2008	1053	CO2 = 840/54 psi																							
7/11/2008	1053	N2 = 18" / 36 psi																							
7/11/2008	1109	Adjusted tank pressures																							
7/11/2008	1109	propane = 16% volume, 37 psi																							
7/11/2008	1109	H2 18 packs = 2300/40 psi; 1650/40 psi; 2300/40 psi																							
7/11/2008	1109	CO2 = 840/52 psi																							
7/11/2008	1109	N2 = 18" / 36 psi																							
7/11/2008	1109	Injected %s --> O2 = 0.0%, Propane = 10%, CO2 = 1.16%, H2 = 11%																							
7/11/2008	1109	P4-18= 47 cfh			P4-28= 49 cfh																				
7/18/2008	946	Control Panel = 56 cfh, 34 psi																							
7/18/2008	946	propane = 48% volume, 38 psi																							
7/18/2008	946	H2 18 packs = 1100/39 psi; 1600/40 psi; 2400/40 psi																							
7/18/2008	946	CO2 = 40/45 psi																							
7/18/2008	946	N2 = 30" / 36 psi																							
7/18/2008	946	P4-18= 46 cfh			P4-28= 49 cfh																				
7/18/2008	946	Injected %s --> O2 = 0.0%, Propane = 11%, CO2 = 0.00%, H2 = 10%																							
7/18/2008	1129	Hooked up new CO2 tank and adjusted tank pressures																							
7/18/2008	1129	propane = 48% volume, 38 psi																							
7/18/2008	1129	H2 18 packs = 1100/39 psi; 1600/40 psi; 2400/40 psi																							
7/18/2008	1129	CO2 = 900/53 psi																							
7/18/2008	1129	N2 = 30" / 36 psi																							
7/18/2008	1129	P4-18= 46 cfh			P4-28= 49 cfh																				
7/18/2008	1129	Injected %s --> O2 = 0.0%, Propane = 10.5%, CO2 = 0.98%, H2 = 11%																							
7/24/2008	1000	Control Panel = 56 cfh, 34 psi																							
7/24/2008	1000	propane = 70% volume, 38 psi																							
7/24/2008	1000	H2 18 packs = 40/40 psi; 1650/41 psi; 2400/42 psi																							
7/24/2008	1000	CO2 = 820/50 psi																							
7/24/2008	1000	N2 = 18" / 36 psi																							
7/24/2008	1000	P4-18= 46 cfh			P4-28= 49 cfh																				
7/24/2008	1000	Injected %s --> O2 = 0.0%, Propane = 10%, CO2 = 0.66%, H2 = 13%																							
7/24/2008	1020	Adjusted tank pressures																							
7/24/2008	1020	propane = 70% volume, 38 psi																							
7/24/2008	1020	H2 18 packs = 40/40 psi; 1650/40 psi; 2400/40 psi																							
7/24/2008	1020	CO2 = 820/53 psi																							
7/24/2008	1020	N2 = 18" / 36 psi																							
7/24/2008	1020	P4-18= 46 cfh			P4-28= 49 cfh																				
7/24/2008	1106	Injected %s --> O2 = 0.0%, Propane = 10%, CO2 = 1.06%, H2 = 10%																							
7/31/2008	1004	Control Panel = 56 cfh, 34 psi																							
7/31/2008	1004	propane = 40% volume, 38 psi																							
7/31/2008	1004	H2 18 packs = 0/40 psi; 700/40 psi; 2100/40 psi																							
7/31/2008	1004	CO2 = 800/53 psi																							
7/31/2008	1004	N2 = 32" / 36 psi																							
7/31/2008	1004	P4-18= 46 cfh			P4-28= 49 cfh																				
7/31/2008	1018	Injected %s --> O2 = 0.0%, Propane = 10.5%, CO2 = 1.26%, H2 = 11%																							
7/31/2008	1103	Injected %s --> O2 = 0.0%, Propane = 10.5%, CO2 = 1.14%, H2 = 10%																							
8/7/2008	840	Control Panel = 56 cfh, 36 psi																							
8/7/2008	840	propane = 75% volume, 38 psi																							
8/7/2008	840	H2 18 packs = 0/40 psi; 0/40 psi; 1600/40 psi																							
8/7/2008	840	CO2 = 40/44 psi																							
8/7/2008	840	N2 = 19" / 37 psi																							
8/7/2008	840	P4-18= 46 cfh			P4-28= 48 cfh																				
8/7/2008	840	Injected %s --> O2 = 0.0%, Propane = 10.5%, CO2 = 0.00%, H2 = 11%																							

Phase II Process Monitoring Data

Date	Time	Nitrogen			Hydrogen			LPG			CO ₂			Helium			CDM-INJ1			CDM-INJ2			CDM-INJ3		
		Pressure (psig)	Rotameter (cfm)	Flow (scfm)	Pressure (psig)	Rotameter (cfm)	Flow (scfm)	Pressure (psig)	Rotameter (cfh)	Flow (scfm)	Pressure (psig)	Rotameter (cfh)	Flow (scfm)	Pressure (psig)	Rotameter (cfm)	Flow (scfm)	Pressure (psig)	Rotameter (cfm)	Flow (scfm)	Pressure (psig)	Rotameter (cfm)	Flow (scfm)	Pressure (psig)	Rotameter (cfm)	Flow (scfm)
8/7/2008	946	Replace CO2 source - 860/46psi																							
8/7/2008	1005	Injected %s --> O2 = 0.0%, Propane = 10%, CO2 = 1.02%, H2 = 10%																							
8/12/2008	928	Control Panel = 56 cfh, 34 psi																							
8/12/2008	928	propane = 50% volume, 38 psi																							
8/12/2008	928	H2 18 packs = 0/39 psi; 0/40 psi; 700/40 psi																							
8/12/2008	928	CO2 = 880/46 psi																							
8/12/2008	928	N2 = 10" / 36 psi																							
8/12/2008	928	P4-18= 45 cfh P4-28= 49 cfh																							
8/12/2008	928	Injected %s --> O2 = 0.0%, Propane = 10.5%, CO2 = 0.00%, H2 = 10%																							
8/12/2008	1049	Adjusted tank pressures																							
8/12/2008	1049	Injected %s --> O2 = 0.0%, Propane = 11%, CO2 = 0.92%, H2 = 5%																							

Optimization Test #8 (100 cfh total of 100% Propane - 50 cfh to P4-18, & P4-28 (50 cfh each))										
Date	Time	System	LPG	Panel Sampling Port	Propane Tank		P4-18		P4-28	
		Pressure (psig)	Rotameter (cfh)	Rotameter (cfm)	Pressure (psig)	Volume (%)	Rotameter 1 (cfh)	Rotameter 2 (cfh)	Rotameter 1 (cfh)	Rotameter 2 (cfh)
9/8/2008	905	34.5	63	60	38	35	25	25	25	25
9/15/2008	901	33.5	67	60	38	60	25	25	25	25
9/15/2008	948	Injected %s --> LPG = 30 % (O2 = 0.0%, CO2 = 0.00%)								
9/29/2008	915	33	75	60	38	60	25	25	25	24
9/29/2008	1010	Injected %s --> LPG = 30 % (O2 = 0.0%, CO2 = 0.00%)								
9/30/2008	949	33	75	60	38	47	25	25	25	24
9/30/2008	957	33	74	58			36	36	12	12
9/30/2008	1005	33	74	58			37	36	12	11
10/13/2008	1134	33	77	58	38	85	36	36	12	12
10/13/2008	1222	Injected %s --> LPG = 30 % (O2 = 0.0%, CO2 = 0.00%)								
10/20/2008	1105	33	76	58	38	60	35	36	12	12
10/20/2008	1152	Injected %s --> LPG = 30 % (O2 = 0.0%, CO2 = 0.00%)								
11/5/2008	1300	34	76	59	38	85	35	36	13	12
11/5/2008	1415	Injected %s --> LPG = 30 % (O2 = 0.0%, CO2 = 0.00%)								
11/17/2008	1052	32	76	58	37.5	60	35	37	12	11
11/17/2008	1143	Injected %s --> LPG = 30 % (O2 = 0.0%, CO2 = 0.00%)								
12/1/2008	1035	33	76	59	38	85	34	36	14	12
12/1/2008	1125	Injected %s --> LPG = 30 % (O2 = 0.0%, CO2 = 0.00%)								

Phase II Tracer Test Injection Data

Well ID ____ INJ1 _____

Date	Time	Well or Injection Gas Sample						Well	Ambient Air	
		O ₂ (%)	CO ₂ (%)	Propane (%)	H ₂ (%)	He (ppm)	RH (%)	Pressure (in wc)	Temperature (C°)	metric pressure (mbar)
12/12/2007	1527							0.18		
12/21/2007	1258	16.2	0.60	0.02	0.22		84.9	0.0	11.4	1012
12/27/2007	1304	9.6	0.58	0	2.4		78.9		9	1016

Tracer Test #1 (10 cfm to INJ2, ~7% H2)										
1/21/2008	1046	Test start								
1/21/2008	1128	1.8	0	0	0.022		58.8	0.03	9.9	1008
1/23/2008	1210*	1.4								

Tracer Test #2 (20 cfm to INJ2, ~8% H2)										
1/18/2008	1120	Test start								
1/18/2008	1229	1.5	0	0	0.046		57.6		13.4	1015
1/18/2008	1557	0.9	0	0	2.8		53.4	0.04	18.3	1014
1/19/2008	1110*	1.3	0.08	0	7.0		76.9		18.6	1018

Tracer Test #3 (30 cfm to INJ2, ~4% H2)										
1/30/2008	1036	Test start								
1/30/2008	1143	0.0	0	0	0.10		91.0	0.10	9.8	1020
1/30/2008	1300	0.0	0	0	1.2		94.0		12.0	1019
1/30/2008	1458	0.0	0	0	2.9		81.7	0.10	15.4	1018
1/31/2008	1015	0.0	0	0	3.9		79.8	0.10	9.4	1019
1/31/2008	1150	0	0	0	3.5		76.8		9.6	1018
1/31/2008	1414	0.0	0	0	3.4		74.9	0.16	8.7	1016
1/31/2008	1435									
1/31/2008	1543	0	0	0	3.4		77.5	0.07	8.4	1014

Tracer Test #4 (60 cfm to INJ2, ~7% H2)										
1/28/2008	1236	Test start								
1/28/2008	1536	0.6	0.04	0	4.2		76.4	0.17	10.2	1011
1/29/2008	835	0	0.04	0	6.6		76.3	-0.04	5.2	1017
1/29/2008	Final O2*	0								

Phase II Tracer Test Injection Data

Well ID INJ1

Date	Time	Well or Injection Gas Sample						Well	Ambient Air	
		O ₂ (%)	CO ₂ (%)	Propane (%)	H ₂ (%)	He (ppm)	RH (%)	Pressure (in wc)	Temperature (C°)	metric pressure (mbar)
Tracer Test #5 (90 cfm to INJ2, ~3% H2)										
2/5/2008	1015	Test start								
2/5/2008	1055	0.2	0	0	0.71		90.4	0.22	10.9	1019
2/5/2008	1158	0.3	0	0	2.1		89.8		11.3	1019
2/5/2008	1405	0.1	0	0	3.3		82.6	0.22	12.8	1018
2/5/2008	1526	0.1	0	0	3.2		55.5		21.2	1019
2/5/2008	1610	0.1	0	0	3.2		69.0		11.7	1018

Tracer Test #6 (30 cfm total; 10 cfm to each INJ1, 2, and 3; ~8% H2)										
2/7/2008	1500	Test start								
2/7/2008	1507	0.0	0	0	7.8		33.1		21.4	1016
2/7/2008	1509	0.0	0	0	7.2		32.3		28.2	1016
2/8/2008	925	0.0	0	0	8.8		59.6	0.16	8.3	1017
2/8/2008	1043	0.0	0	0	8.2		77.8		10.2	1017

H2ave = 8.000

Tracer Test #7 (60 cfm total; 20 cfm each to INJ1, 2, and 3; ~5% H2)										
1/17/2008	900	Test start								
1/17/2008	1257	0.1	0	0	5.1		8.4	0.10	11.9	1013

H2ave = 5.100

Tracer Test #8 (90 cfm total; 30 cfm each to INJ1, 2, and 3; ~4.5% H2)										
2/6/2008	1000	Test start								
2/6/2008	1006	0.0	0	0	4.6		90.4	0.54	10.2	1020
2/6/2008	1111	0.0	0	0	4.5		39.0		11.8	1020
2/6/2008	1213	0.0	0	0	4.3		52.6		13.4	1019
2/6/2008	1403	0.0	0	0	5.1		41.1	0.58	15.4	1017
2/6/2008	1515	0.0	0	0	4.7		43.2		17.6	1017

H2ave = 4.640

Phase II Tracer Test Injection Data

Well ID INJ2

Depth _____

Source file: Test 8 - 6 Feb 2008.xls

Date	Time	Well or Injection Gas Sample							Well	Ambient Air
		O ₂ (%)	CO ₂ (%)	Propane (%)	H ₂ (%)	He (ppm)	RH (%)	Pressure (in wc)	Temperature (C°)	Barometric pressure (mbar)
12/12/2007	1522							9.9		
12/13/2007	840	0	0	0	8.1	10 ^{^5}	11.3	4.3	5.1	1016
12/13/2007	1328	0	0	0	8.5		10.9		17.1	1014
12/13/2007	1424	0	0.70	0.54	0.22		6.2		15.2	1013
12/13/2007	1554	0	0.70	0.52	0.022		13.9		13.0	1013
12/14/2007	834	0	0	0	0.22			0.11	5.4	1016
12/21/2007	1122	10.3	0.90	0.08	0.22		60.8	0.01	13.2	1013
12/26/2007	1355	0.2	0	0	0.57		12.3	0.1	11.9	1015
12/26/2007	1425	0.1	0	0	8.4					
12/27/2007	925	0.1	0	0	9.1		6.6	0.06	5.3	1017
12/27/2007	1244	0.1	0	0	9		6.9		9.3	1017
12/27/2007	1525	0.2	0	0	9.6		7.2	0.08	7.9	1017
1/2/2008	933	0.1	0	0	0.22		4.5	0.04	9.5	1012

Tracer Test #1 (10 cfm to INJ2, ~7% H2)										
1/21/2008	1046	Test start								
1/21/2008	1049		0.9	0	0	6.4		46.5	7.8	1007
1/21/2008	1121		0.9	0	0	6.4		43.8	9.1	1007
1/21/2008	1241		0.8	0	0	6.2		34.5	0.21	9.9
1/21/2008	1439		0.8	0	0	6.3		15.6	0.22	10.1
1/21/2008	1624		0.9	0	0	6.3				
1/22/2008	908		0.8	0	0	7.1		23.3	0.20	7.5
1/22/2008	1200*		0.1	0	0	6.8				
1/23/2008	946		0.7	0	0	6.6		59.2	0.20	9.0
1/23/2008	1104*		0.3			6.8				
					H2ave =	6.544				

Tracer Test #2 (20 cfm to INJ2, ~8% H2)										
1/18/2008	1120	Test start								
1/18/2008	1123		0.5	0	0	8.8		54.5	0.06	12.3
1/18/2008	1143		0.5	0	0	7.4				
1/18/2008	1300		0.5	0	0	6.9				
1/18/2008	1552*		0.1	0	0	7.8		4.2	0.12	22.3
1/19/2008	848		0.5	0	0	7.9		15.3		7.4
1/19/2008	1015*		0.1	0	0	5.8		8.9	0.14	13.6
					H2ave =	7.433				

Tracer Test #3 (30 cfm to INJ2, ~4% H2)										
1/30/2008	1036	Test start								
1/30/2008	1043		0.0	0	0	4.6		26.1	0.50	9.2
1/30/2008	1153		0.0	0	0	4.4		24.7		10.1
1/30/2008	1406		0.0	0	0	4.7		37.0	0.50	12.3
1/31/2008	920		0.0	0	0	4.1		39.8	0.50	7.9
1/31/2008	1121		0	0	0	3.6		42.8		9.4
1/31/2008	1318		0	0	0	3.4		43.3	0.53	8.5
1/31/2008	1342		0	0	0	3.9		28.2		8.7
1/31/2008	1435									
1/31/2008	1453		0.0	0	0	3.6		43.9	0.08	7.9
1/31/2008	1555		0.0	0	0	3.7		48.0		8.0
					H2ave =	4.100				

Phase II Tracer Test Injection Data

Well ID INJ2

Depth _____

Source file: Test 8 - 6 Feb 2008.xls

Date	Time	Well or Injection Gas Sample						Well	Ambient Air
		O ₂ (%)	CO ₂ (%)	Propane (%)	H ₂ (%)	He (ppm)	RH (%)	Pressure (in wc)	Temperature (C°)
Tracer Test #4 (60 cfm to INJ2, ~7% H2)									
1/28/2008	1236								
1/28/2008	1239	0	0	0	6.4		76.4	1.95	10.4
1/28/2008	1337	0	0	0	5.7				
1/28/2008	1340*	0	0	0	6.2				
1/28/2008	1535	0	0	0	6.0		70.8	1.90	10.3
1/29/2008	741	0	0	0	7.1		43.5	1.70	5.9
1/29/2008	1010*	0			6.6				
					H2ave =	6.333			
Tracer Test #5 (90 cfm to INJ2, ~3% H2)									
2/5/2008	1015								
2/5/2008	1016	0	0	0	3.5		11.0	2.4	8.3
2/5/2008	1051	0	0	0	3.3				1019
2/5/2008	1117	0	0	0	3.5		13.2		10.5
2/5/2008	1324	0	0	0	4.0		23.2	2.40	12.0
2/5/2008	1435	0	0	0	3.7				14.8
2/5/2008	1541	0	0	0	3.5		23.9		16.8
					H2ave =	3.583			
Tracer Test #6 (30 cfm total; 10 cfm to each INJ1, 2, and 3; ~8% H2)									
2/7/2008	1500								
2/7/2008	1504	0.0	0	0	7.8		13.8		21.1
2/7/2008	1609	0.0	0	0	7.2		25.7		22.9
2/8/2008	1001	0.0	0	0	8.8		37.2		13.0
2/8/2008	1051	0.0	0	0	8.6		45.3		10.6
					H2ave =	8.100			
Tracer Test #7 (60 cfm total; 20 cfm to each INJ1, 2, and 3, ~5% H2)									
1/17/2008	900								
1/17/2008	917	0.4	0	0	4.7		69.5	0.06	2.5
1/17/2008	1119	0.4	0	0	4.9		55		10.0
1/17/2008	1302*	0.1							
					H2ave =	4.800			
Tracer Test #8 (90 cfm total; 30 cfm each to INJ1, 2, and 3; ~4.5% H2)									
2/6/2008	1000								
2/6/2008	1001	0.0	0	0	4.6		22.4	0.64	9.8
2/6/2008	1125	0.0	0	0	4.4		32.1		12.1
2/6/2008	1231	0.0	0	0	4.3		27.5		13.4
2/6/2008	1415	0.0	0	0	5.0		29.8	0.65	15.8
2/6/2008	1524	0.0	0	0	4.7		36.0		16.1
					H2ave =	4.600			

Phase II Tracer Test Injection Data

Well ID INJ3

Depth _____

Source file: Test 8 - 6 Feb 2008.xls

Date	Time	Well or Injection Gas Sample							Well	Ambient Air
		O ₂ (%)	CO ₂ (%)	Propane (%)	H ₂ (%)	He (ppm)	RH (%)	Pressure (in wc)	Temperature (C°)	Barometric pressure (mbar)
12/12/2007	1528							0.12		
12/13/2007	1319							0.10		
12/21/2007	1155	16.6	0.42	0	0.22		86.6	0.02	10.1	1013
12/27/2007	1307	9.9	0.42	0	2.9		78.8		8.8	1016
1/2/2008	1027	4.0	0.52	0	0.22		71.8	0.02	17.7	1012
Tracer Test #1 (10 cfm to INJ2, ~7% H2)										
1/21/2008	1046	Test start								
1/21/2008	1136	2.0	0	0	0.022		61.4		9.8	1008
1/23/2008	1135*	0.6	0.02	0	4.5					
Tracer Test #2 (20 cfm to INJ2, ~8% H2)										
1/18/2008	1120	Test start								
1/18/2008	1248	1.4	0	0	0.022		83.1		13.7	1014
1/18/2008	1555*	0.5	0	0	1.2		44.6	0.03	19.5	1014
1/19/2008	1151*	0.4	0.02	0	7.0		92.4		13.4	1018
Tracer Test #3 (30 cfm to INJ2, ~4% H2)										
1/30/2008	1036	Test start								
1/30/2008	1057	0.0	0	0	0.046		86.1	0.12	9.6	1020
1/30/2008	1238	0.0	0	0	0.046		80.3		11.0	1019
1/30/2008	1446	0.0	0	0	1.5		72.0	0.16	15.0	1018
1/31/2008	1004	0.0	0	0	3.6		82.1	0.18	9.4	1019
1/31/2008	1143	0.1	0	0	3.2		81.4		9.6	1018
1/31/2008	1405	0	0	0	3.4		80.4	0.09	8.7	1016
1/31/2008	1435									
1/31/2008	1527	0.1	0	0	3.3		83.0	0.04	8.4	1014
Tracer Test #4 (60 cfm to INJ2, ~7% H2)										
1/28/2008	1236	Test start								
1/28/2008	1615	1.2	0.02	0	3.5		76.9		9.9	1012
1/29/2008	819	0.1	0.04	0	7.0		81.7	0.14	5.1	1017
1/29/2008	Final O2*	0.1								

Phase II Tracer Test Injection Data

Well ID INJ3

Depth _____

Source file: Test 8 - 6 Feb 2008.xls

Date	Time	Well or Injection Gas Sample							Well	Ambient Air
		O ₂ (%)	CO ₂ (%)	Propane (%)	H ₂ (%)	He (ppm)	RH (%)	Pressure (in wc)	Temperature (C°)	Barometric pressure (mbar)
Tracer Test #5 (90 cfm to INJ2, ~3% H2)										
2/5/2008	1015	Test start								
2/5/2008	1150	0.3	0	0	1.1		75.1	0.11	11.3	1019
2/5/2008	1357	0.2	0	0	2.7		79.7	0.14	12.8	1018
2/5/2008	1519	0.1	0	0	2.9		45.8		22.0	1019
2/5/2008	1603	0.1	0	0	2.9		55.5		19.6	1018
Tracer Test #6 (30 cfm total; 10 cfm to each INJ1, 2, and 3; ~8% H2)										
2/7/2008	1500	Test start								
2/7/2008	1505	0.0	0	0	7.7		44.9		21.3	1016
2/7/2008	1558	0.0	0	0	7.2		25.2		28.0	1016
2/8/2008	1033	0.0	0	0	8.5		34.8		10.0	1017
H2ave = 7.800										
Tracer Test #7 (60 cfm total; 20 cfm to each INJ1, 2, and 3, ~5% H2)										
1/17/2008	900	Test start								
1/17/2008	1255	0.2	0	0	5.1		52.0	0.27	11.9	1014
H2ave = 5.100										
Tracer Test #8 (90 cfm total; 30 cfm each to INJ1, 2, and 3; ~4.5% H2)										
2/6/2008	1000	Test start								
2/6/2008	1005	0.0	0	0	4.6		65.8	1.05	10.0	1020
2/6/2008	1204	0.0	0	0	4.3		55.8		13.4	1020
2/6/2008	1259	0.0	0	0	4.1		71.8		14.5	1019
2/6/2008	1452	0.0	0	0	4.8		62.5	1.05	16.0	1017
2/6/2008	1550	0.0	0	0	4.6		44.7		19.1	1017
H2ave = 4.480										

**Table
Soil Analytical Data**

Sample	PID (ppm)	USCS Soil Type	Perchlorate		Nitrate		Moisture %
			µg/kg (dry)	flag	mg-N/kg (dry)	flag	
P4-10-102907	0.1	CL	14667		4.4		25
P4-15-102907	0.0	CL	25000		6.4		36
P4-15-D	NA	NA	17647		5.7		32
P4-20-102907	0.0	CL	21875		8.0		36
P4-30-102907	0.0	SP	28125		8.6		36
P4-40-102907	0.1	CL	19403		6.9		33
P4-40-D	NA	NA	18667		7.1		25
P4-50-102907	0.0	SW	1116		2.0		14
P3-10-102307	0.1	CL/SP	75342		5.6		27
P3-20-102307	0.0	CL/SW	75362		7.8		31
P3-30-102307	0.5	GC/CL	68657		7.0		33
P3-40-102307	0.0	CL	33333		4.5		22
P3-50-102307	1.2	GW	2907		3.1		14
CDM-INJ2-10-102607	0.0	CL/ML	4324		5.0		26
CDM-INJ2-20-102607	0.0	CL	8806		6.4		33
CDM-INJ2-25-102607	0.0	CL	5921		5.0		24
CDM-INJ2-25-D	NA	NA	4459		3.9		26
CDM-INJ2-30-102607	0.0	SM	4524		3.6		16
CDM-INJ2-40-102607	0.0	GC	2556		3.0		10
CDM-INJ2-50-102607	0.0	SP-SM	282		3.6		15
P5-10-102407	0.0	CL	7206		5.3		32
P5-20-102407	0.0	CL	3944		5.6		29
P5-30-102407	0.2	CL/SW	3433		6.4		33
P5-40-102407	0.0	CL/SC	4571		7.0		30
P5-50-102407	0.0	SP	1798		3.5		11
CDM-INJ1-US-073106-15	NA	ML	41000		5.2		19.9
CDM-INJ1-US-073106-20	NA	CL/GC	73000		10.0		34.6
CDM-INJ1-US-073106-35	NA	SM	17000		2.3		13.7
CDM-INJ1-US-073106-50	NA	SM	7700		2.2		13.2
CDM-INJ1-US-073106-70	NA	SM	5700		1.6		7.8
CDM-INJ3-10-101807	0.0	GC	333333		37.7		31
CDM-INJ3-20-101807	0.0	GC	36111		3.8		28
CDM-INJ3-30-101807	0.0	SM	22222		4.3		19
CDM-INJ3-40-101807	0.0	ML/SP	9302		2.9		14
CDM-INJ3-50-101807	0.0	SW	3444		2.8		10
P6-10-102207	0.6	CL/GC	1068		3.9		26
P6-20-102207	0.2	CL/GW	13415		4.4		18
P6-30-102207	2.5	SP/CL	1957		2.6		8
P6-40-102207	0.0	GM/SW	5435		2.7		8
P6-50-102207	0.0	SW	11023		3.1		12
P2-05-102507	0.3	CL	597222		5.8		28
P2-05-D	NA	NA	463768		15.9		31
P2-10-102507	0.0	CL	231884		27.5		31
P2-20-102507	0.2	GW	242857		15.7		30

Sample	PID (ppm)	USCS Soil Type	Perchlorate		Nitrate		Moisture %
			µg/kg (dry)	flag	mg-N/kg (dry)	flag	
P2-20-D	NA	NA	388889		16.7		28
P2-30-102507	0.5	GW	47561		8.5		18
P2-40-102507	0.0	SP/CL	12088		4.2		9
P2-50-102507	0.0	CL	51724		5.3		13
P7-10-101607	162.0	ML	14030		4.5		33
P7-20-101607	63.0	GM	13187		3.7		9
P7-30-101607	86.0	CL/SP	21429		3.0		16
P7-40-101607	28	SP	6047		3.6		14
CDM-P1-US-072706-15	NA	ML	11	U	3.2		10.1
CDM-P1-US-072706-25	NA	GC	1300		4.0		12.6
CDM-P1-US-072706-35	NA	SP/GC	5000		1.8		6.9
CDM-P1-US-072706-45	NA	GC/SM	8500		2.2		10.8
CDM-P1-US-072706-70	NA	SM	12000		1.3		16.7
P8-10-101107	55.9	CL/GW	75000		8.5		40
P8-30-101107	110.0	GC/GP	4048		3.1		16
P8-40-101207	217.0	GP-GC/SP-SC	89		3.0		17
P8-50-101207	184.0	GW	18	J	2.6		16
CDM-CB-1-041808-10	2.2	CL	4598		0.6		30.4
CDM-CB-1-041808-20	1.4	GC	4454		0.8		30.4
CDM-CB-1-041808-30	2.2	GW/CL	7018		0.6		31.6
CDM-CB-1-041808-30D	NA	NA	2479		0.2		15.3
CDM-CB-1-041808-40	2.6	GW	1487		0.4		12.6
CDM-CB-1-041808-50	3.0	GW	869		0.2		14.8
CDM-CB-2-041808-10	24.9	ML/CL	8905		0.4		31.5
CDM-CB-2-041808-20	1.7	SW	657		0.3		7.14
CDM-CB-2-041808-30	6.2	GW	2576		0.2	U	37.9
CDM-CB-2-041808-30D	NA	GW-GM	5196		0.1		13.4
CDM-CB-2-041808-40	4.6	GW	12277		0.5		10.4
CDM-CB-2-041808-50	12.5	GW	2700		0.2		11.1
CDM-CB3-10-061008	NA	CL	21277		0.6		29.5
CDM-CB3-20-061008	NA	GP	7859		0.4		9.66
CDM-CB3-30-061008	NA	GM	3869		0.1	U	9.53
CDM-CB3-30D-061008	NA	NA	5875		0.7		14.9
CDM-CB3-40-061008	NA	GP	1582		0.6		11.5
CDM-CB3-50-061008	NA	GP	1076		0.1		7.97
CDM-CB4-10-061008	NA	CL	191458		14.4		32.1
CDM-CB4-20-061008	NA	GC/CL	12065		2.6		8.83
CDM-CB4-30-061008	NA	GC/ML	12135		0.8		9.35
CDM-CB4-30D-061008	NA	NA	14192		1.0		8.4
CDM-CB4-40-061008	NA	GP-GM	22379		0.9		15.1
CDM-CB4-50-061008	NA	GM	5297		0.1	U	9.38
CDM-CB5-10-071008	NA	MLCL	310		0.2		29.3
CDM-CB5-20-071008	NA	SM	2200		0.5		34.6
CDM-CB5-25-071008	NA	SM	3200		0.5		36.9
CDM-CB5-30D-071008	NA	NA	370		0.1		9.6
CDM-CB5-40-071008	NA	SM	1400		0.4		15.6
CDM-CB5-50-071008	NA	SM	1600		0.1		10.4
CDM-CB6-10-071008	0	CL/ML	51000		0.2		28
CDM-CB6-20-071008	0	CL/SM	4000		0.2		31
CDM-CB6-25-071008	0	SM	1700		0.2		15.8
CDM-CB6-30-071008	0	SM	1200		0.1		19.1
CDM-CB6-40-071008	0	GM/SM	2500		0.1		11.8
CDM-CB6-50-071008	0	SM	4400		0.1		10.1
CDM-CB7-10-090208	NA	CL	16000		0.2		29.5
CDM-CB7-20-090208	NA	CL	3800		1.1		32.9
CDM-CB7-30-090208	NA	CL	8000		0.9		31.5

Sample	PID (ppm)	USCS Soil Type	Perchlorate		Nitrate		Moisture %
			µg/kg (dry)	flag	mg-N/kg (dry)	flag	
CDM-CB7-30D-090208	NA	NA	8800		0.9		33
CDM-CB7-40-090208	NA	GM	210		0.1		11.3
CDM-CB7-50-090208	NA	GM	1400		0.1		17.7
CDM-CB8-10-090208	NA	CL	560000		13.0		36
CDM-CB8-20-090208	NA	GC	37000		5.3		11
CDM-CB8-30-090208	NA	GW	16000		0.2		4.4
CDM-CB8-30D-090208	NA	NA	27000		0.2		6.8
CDM-CB8-40-090208	NA	GM	56000		0.1		19.9
CDM-CB8-50-090208	NA	GM	1800		0.2		23
CDM-CB9-10-120208	NA	GW	120		0.4		19.5
CDM-CB9-20-120208	NA	CL	960		0.2		22.1
CDM-CB9-30-120208	NA	CL	150		0.3		11.3
CDM-CB9-30D-120208	NA	NA	140		0.2		9.4
CDM-CB9-40-120208	NA	GM	350		0.3		12.1
CDM-CB9-50-120208	NA	SW	1500		0.5		9.3
CDM-CB10-10-120208	NA	GW	26000		0.1		10.5
CDM-CB10-20-120208	NA	CL	11000		0.1		16.3
CDM-CB10-30-120208	NA	GW	270		0.2		10.3
CDM-CB10-30D-120208	NA	NA	130		0.2		9.5
CDM-CB10-40-120208	NA	GW/GM	8800		0.2		10.1
CDM-CB10-50-120208	NA	GW	210		0.3		13.5
CDM-CB11-10-120308	NA	GW/GM	47000		0.4		9.4
CDM-CB11-20-120308	NA	GM	14000		1.5		16.7
CDM-CB11-30-120308	NA	GC	23000		0.1		16.9
CDM-CB11-30D-120308	NA	NA	18000		0.1		14.9
CDM-CB11-40-120308	NA	ML	26000		0.5		13.3
CDM-CB11-50-120308	NA	GW	11000		0.9		8.4
CDM-CB12-10-120308	NA	CL	7500		0.5		31.1
CDM-CB12-20-120308	NA	GM	7600		3.4		27.9
CDM-CB12-30-120308	NA	GW	1400		0.1	U	9.3
CDM-CB12-30D-120308	NA	NA	780		0.1	U	9.8
CDM-CB12-40-120308	NA	GW/GM	25000		0.1		7.2
CDM-CB12-50-120308	NA	GW	9400		0.4		8.3
CDM-CB13-10-120308	NA	CL	110000		2.7		30.2
CDM-CB13-20-120308	NA	GM	140000		1.0		29.3
CDM-CB13-30-120308	NA	GM	15000		0.1	U	11.4
CDM-CB13-30D-120308	NA	NA	15000		0.1		10.7
CDM-CB13-40-120308	NA	GM	6900		0.1		8.2
CDM-CB13-50-120308	NA	GW	4300		0.3		7.2
CDM-CB14-10-120308	NA	CL	14	U	0.1		27.8
CDM-CB14-20-120308	NA	CL	24		0.2		31
CDM-CB14-30-120308	NA	GM	1400		0.1	U	6.8
CDM-CB14-30D-120308	NA	NA	2900		0.1		7.8
CDM-CB14-40-120308	NA	GM	1600		0.4		15.4
CDM-CB14-50-120308	NA	GM	2700		0.3		9.1
CDM-CB15-10-120308	NA	CL	15	U	0.2		31.6
CDM-CB15-20-120308	NA	CL	35		0.1		31.8
CDM-CB15-30-120308	NA	GW	1200		0.1		9.1
CDM-CB15-30D-120308	NA	NA	3200		0.1		9.7
CDM-CB15-40-120308	NA	GC	390		0.1		14.7
CDM-CB15-50-120308	NA	GW	2300		0.1		9.1
CDM-CB16-10-120308	NA	CL	15	U	0.2		32.4
CDM-CB16-20-120308	NA	CL	15	U	0.1		35.5
CDM-CB16-30-120308	NA	GW	13	U	0.1		25.6
CDM-CB16-30D-120308	NA	NA	13	U	0.1		23.4
CDM-CB16-40-120308	NA	GM	440		0.1		13.5
CDM-CB16-50-120308	NA	GM	3100		0.24		9.1

Sample	PID (ppm)	USCS Soil Type	Perchlorate		Nitrate		Moisture %
			µg/kg (dry)	flag	mg-N/kg (dry)	flag	
CDM-CB17-10-120308	NA	CL	660		0.15		32.00
CDM-CB17-20-120308	NA	CL	4900		2.9		30.80
CDM-CB17-30-120308	NA	GM	8800		0.1	U	11.60
CDM-CB17-30D-120308	NA	NA	6800		0.1		9.50
CDM-CB17-40-120308	NA	CL	3800		1.1		25.10
CDM-CB17-50-120308	NA	GW	700		0.3		6.10
CDM-CB18-10-120308	NA	CL	48000		0.1		18.20
CDM-CB18-20-120308	NA	CL	3000		0.1		31.40
CDM-CB18-30-120308	NA	GC	7400		0.1		19.40
CDM-CB18-30D-120308	NA	NA	9900		0.2		16.70
CDM-CB18-40-120308	NA	GM	1900		0.1		11.60
CDM-CB18-50-120308	NA	GM	2900		0.1		7.10
CDM-CB19-10-120308	NA	CL	160000		8.0		32.30
CDM-CB19-20-120308	NA	GW	59000		4.2		19.30
CDM-CB19-30-120308	NA	GW-GM	13000		0.1		7.50
CDM-CB19-30D-120308	NA	NA	8400		0.1		7.70
CDM-CB19-40-120308	NA	GW-GM	25000		0.4		10.30
CDM-CB19-50-120308	NA	GW-GM	4900		0.8		8.30

Notes

PID - Photoionization detector

USCS - Unified Soil Classification System

µg/kg - Micrograms per kilogram

mg-N/kg - Milligrams nitrogen per kilogram

ppm - parts per million

U - Not detected

NA - Not analyzed

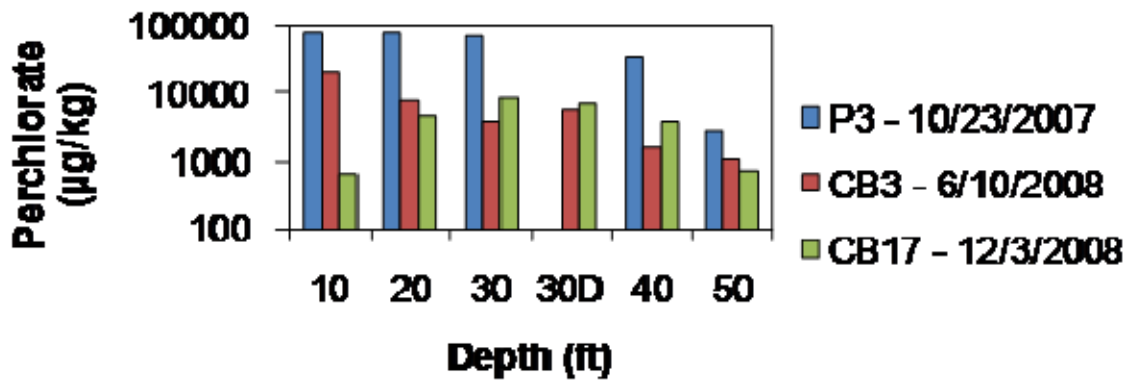
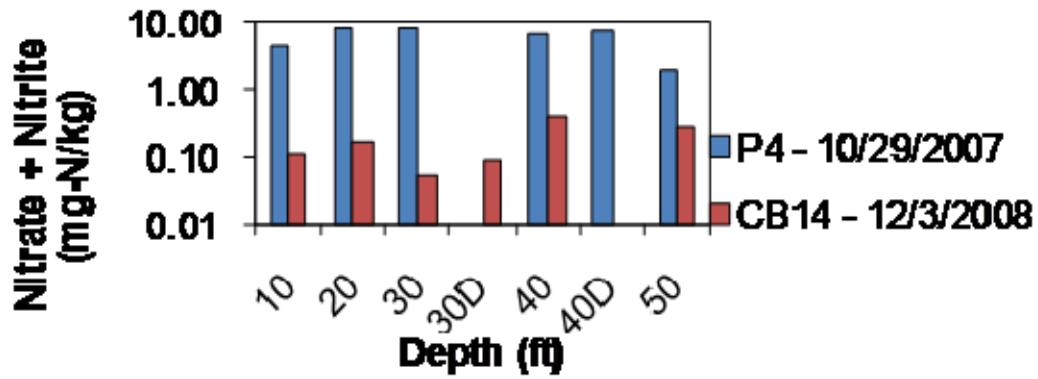
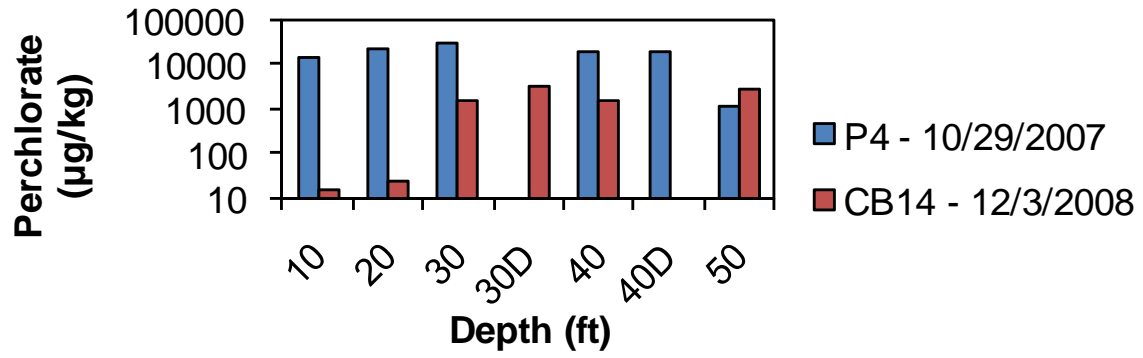

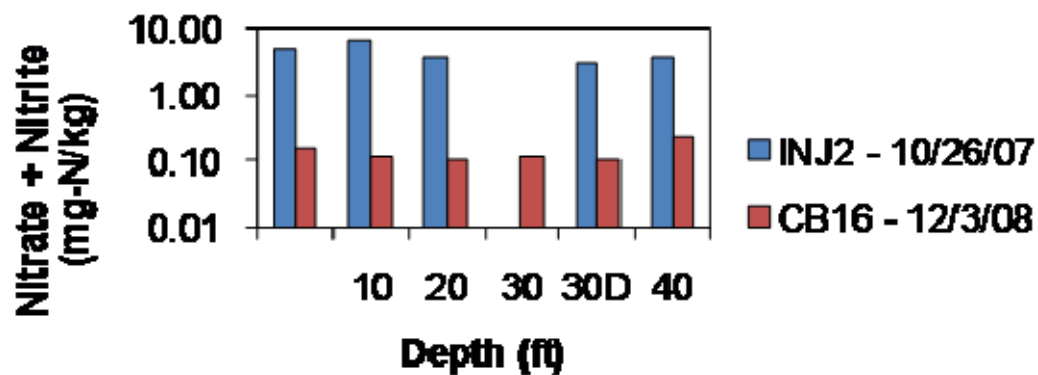
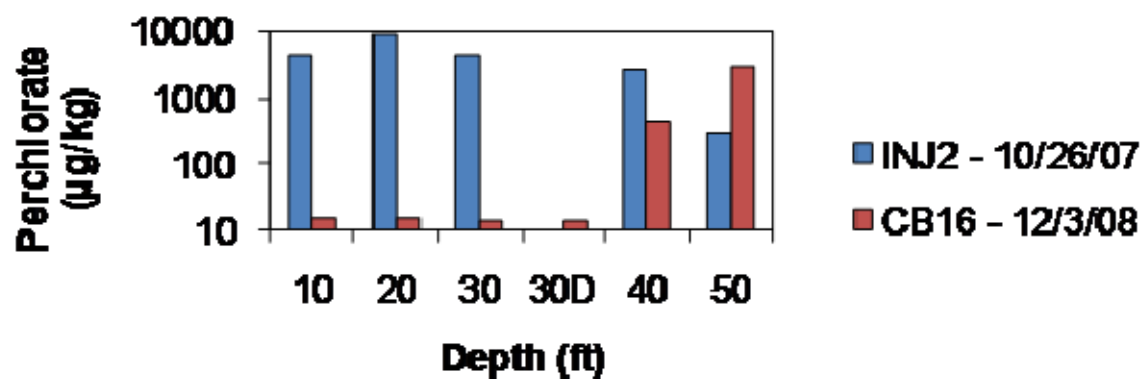
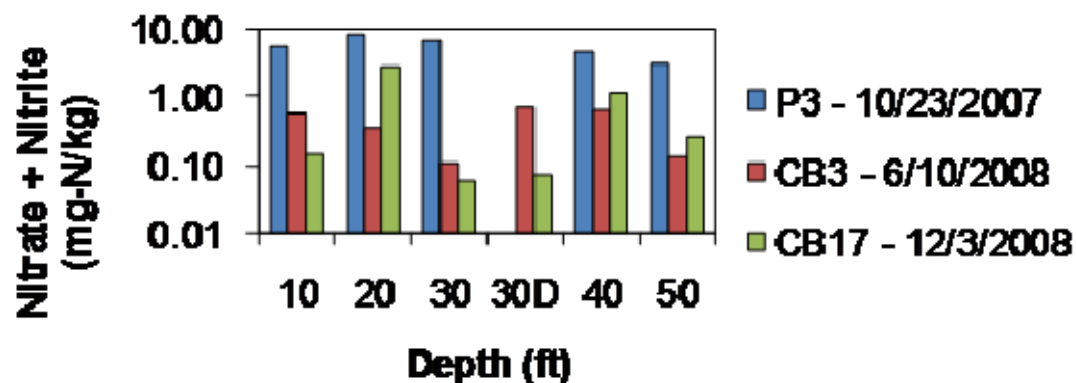

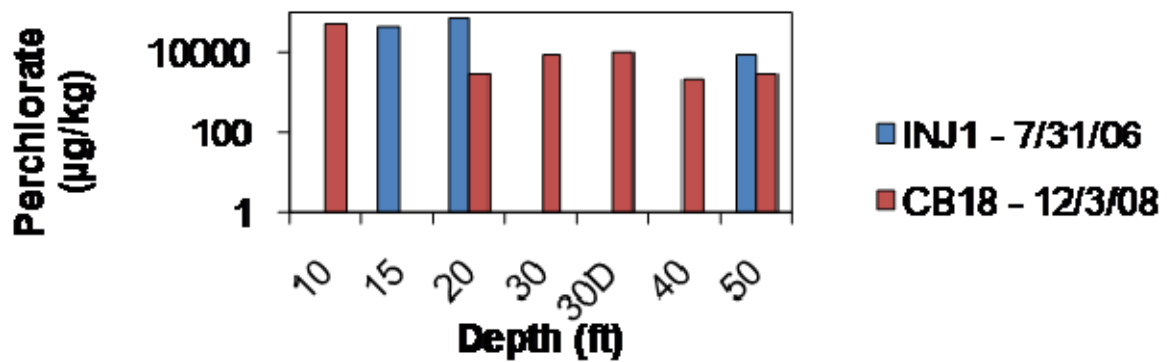
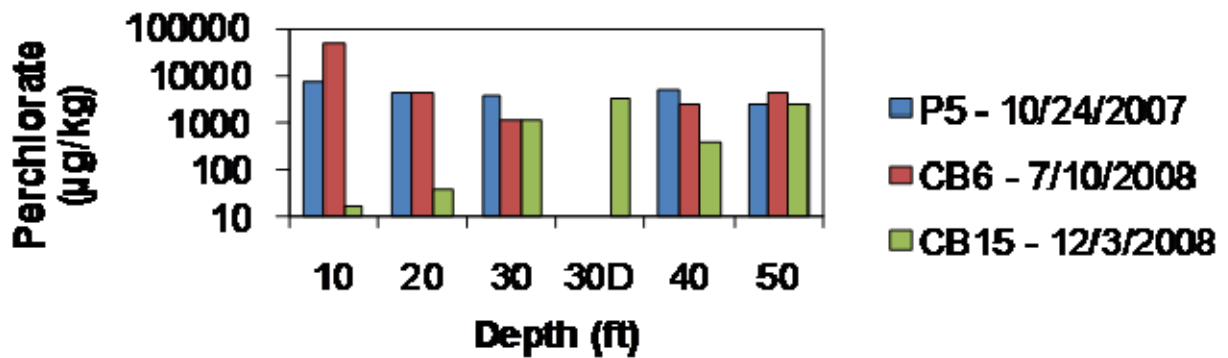
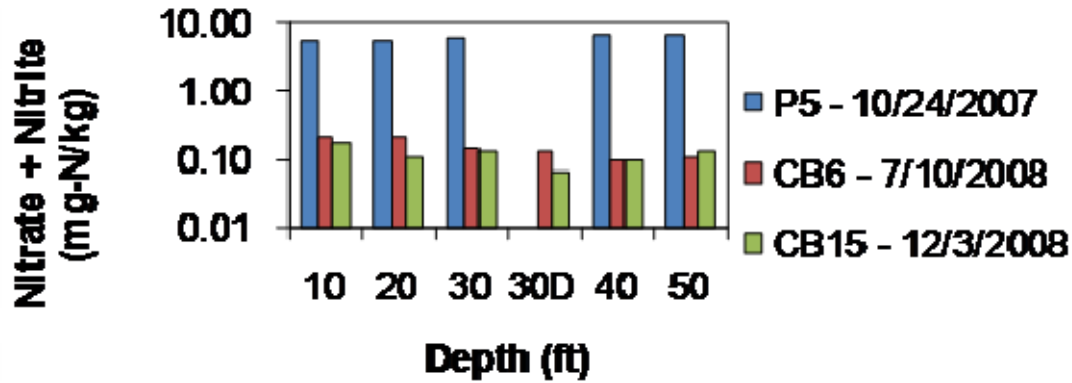

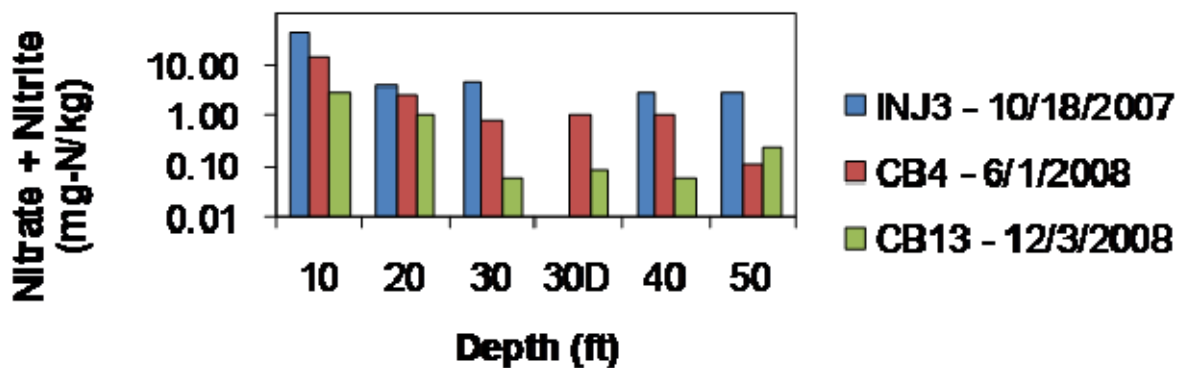
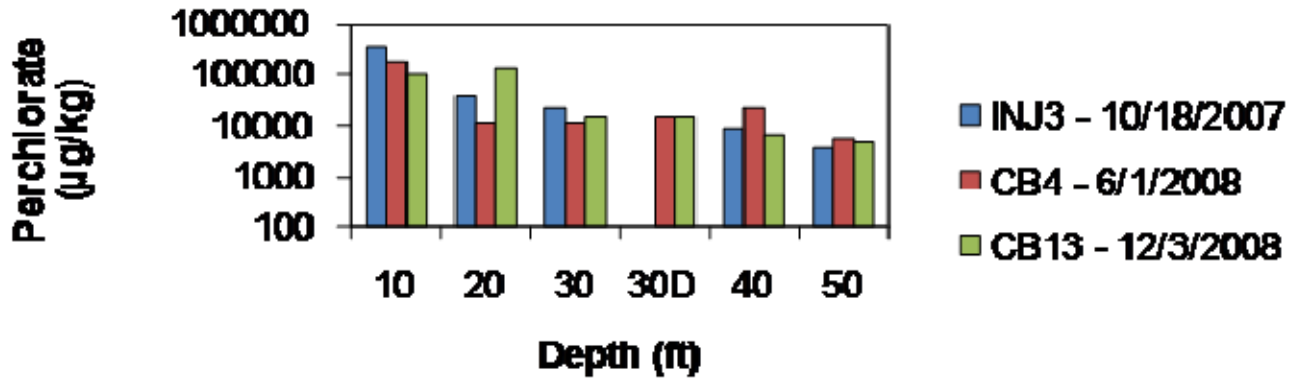
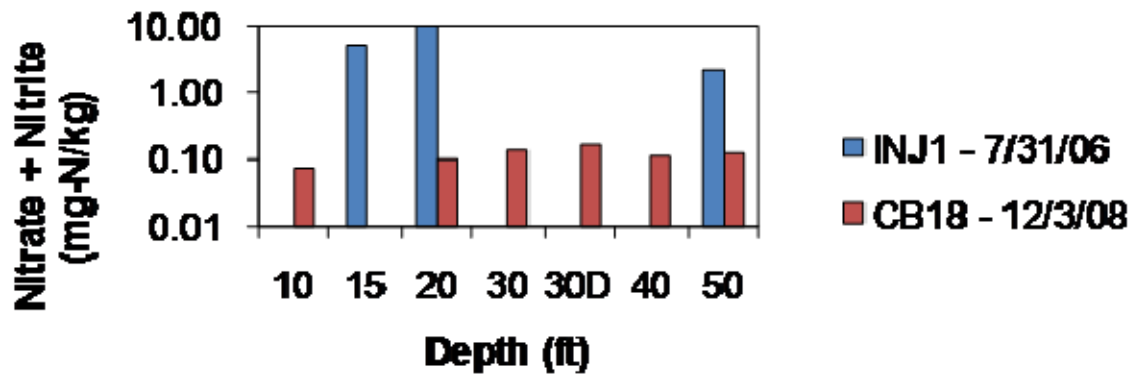

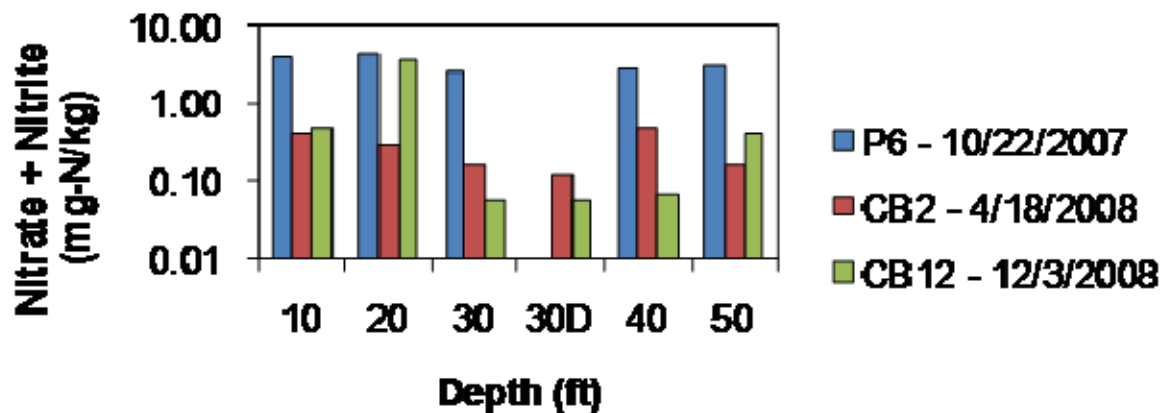
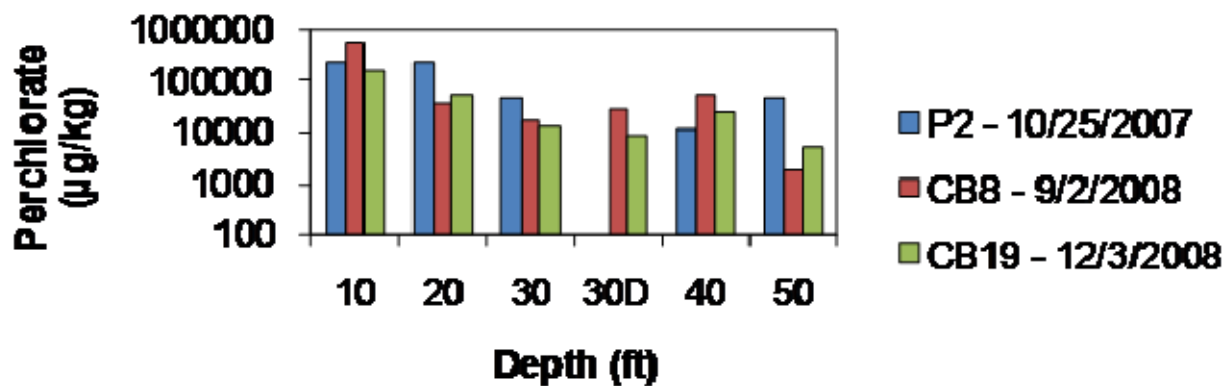
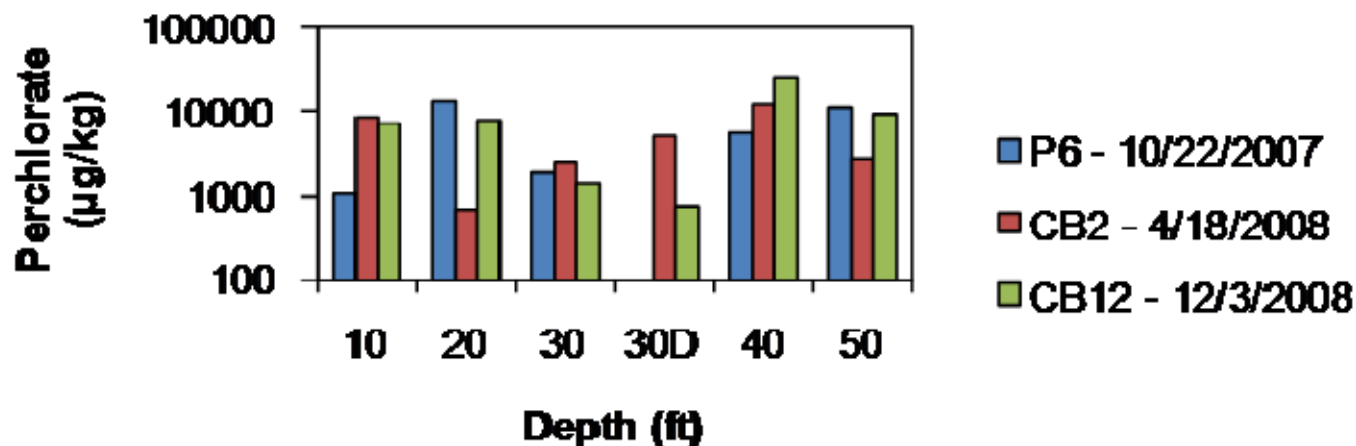

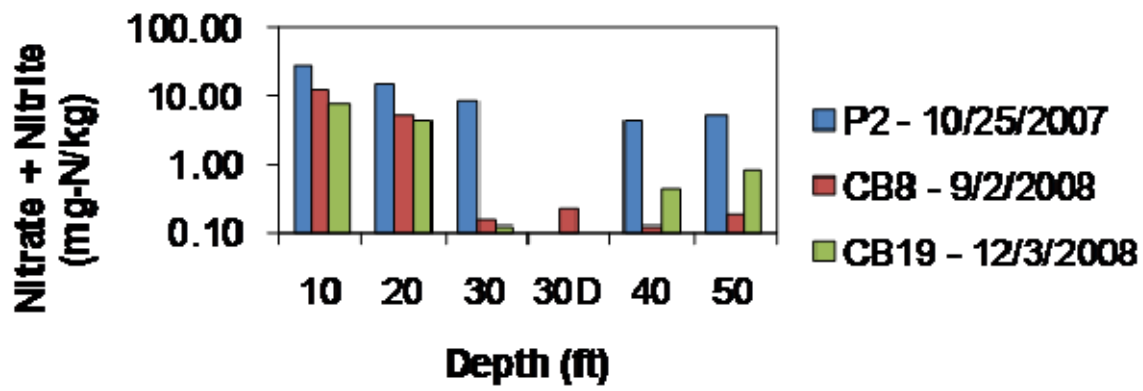

Appendix D: Treatability Test Report

Appendix A

Treatability Test Report

In Situ Bioremediation of Perchlorate in Vadose Zone Using Gaseous Electron Donors.

**ESTCP Project ER-0511
Propellant Burn Area
Inactive Rancho Cordova Test Site
Rancho Cordova, California**



September 2007

Table of Contents

List of Figures	iii
List of Tables	v
Acronyms	vi
1.0 Introduction.....	1
2.0 Soil Borings, Lithology, Sample Collection, Sample Analysis Results, and Well Installation	2
2.1 Pre-Field Activities.....	2
2.2 Drilling	2
2.3 Well Construction.....	4
2.4 Decontamination.....	4
2.5 Lithology	7
3.0 Microcosm Tests.....	15
3.1 Abstract.....	15
3.2 Materials and Methods	15
3.2.1 Soil Characterization.....	15
3.2.2 Experimental Design and Setup	15
3.2.3 Chemical Analyses.....	18
3.3 Microcosm Test Results	19
3.4 Discussion.....	22
4.0 Column Test Results.....	28
4.1 Abstract.....	28
4.2 Materials and Methods	28
4.2.1 Experimental Design and Setup	28
4.3 Results	31
4.3.1 Hydrogen Column.....	31
4.3.2 Four-Gas-Mixture Column	33
4.4 Discussion.....	37
5.0 Air Injection Test.....	41
5.1 Introduction and Method	41
5.2 Results	41
6.0 Overall Data Assessment.....	44
6.1 Deviations from the Work Plan.....	44
6.2 Evaluation of Data Quality and Data Quality Objectives	44
7.0 Conclusions.....	46
8.0 References.....	47

List of Figures

Figure 2-1	Proposed Locations of Soil Borings/ Pilot Test Wells Propellant Burn Area	3
Figure 2-2	As-Built Well Detail CDM-INJI GEDIT-AEROJET	5
Figure 2-3	As-Built Well Detail CDM-PI GEDIT - AEROJET.....	6
Figure 2-4	CDM-INJ1 Grain Size Distribution	10
Figure 2-5	CDM-P1 Grain Size Distribution.....	10
Figure 2-6	Generalized Lithologic Cross Section GEDIT Air-Injection Pilot Test.....	11
Figure 2-7	CDM-INJ1 Contaminant and Moisture Distribution	14
Figure 2-8	CDM-P1 Contaminant and Moisture Distribution.....	14
Figure 3-1	Perchlorate Degradation in Microcosm Tests with Different Electron Donors at 16% Soil Moisture.....	20
Figure 3-2	Relative Change in Perchlorate Concentration Over Time Used to Estimate First Order Rate Constants.....	21
Figure 3-3	Perchlorate and Hydrogen Concentration Changes Over Time in Negative Control Microcosms Containing no External Electron Donor at 16% Soil Moisture	26
Figure 4-1	Schematic and Photograph of the GEDIT Column System in the Laboratory	29
Figure 4-2	Hydrogen Breakthrough Curves for Column #1 and #2 with 10% Soil Moisture	31
Figure 4-3	Perchlorate, Chloride, Hydrogen, Nitrate, and Soil Moisture along Column Length in Column #1 after 4 Weeks of Incubation.....	32
Figure 4-4	Perchlorate, Chloride, Hydrogen, Nitrate, and Soil Moisture along Column Length in Column #2 after 10 Weeks of Incubation.....	33
Figure 4-5	Hydrogen Breakthrough Curves for Column #3 and #4 with 10% Soil Moisture	34
Figure 4-6	LPG, H ₂ , and CO ₂ Profiles along the Length of Column #3 at the Start of Incubation	35
Figure 4-7	LPG, H ₂ , and CO ₂ Profile along the Length of Column #4 at the Start of Incubation	35
Figure 4-8	Perchlorate, Chloride, Hydrogen, Nitrate, and Soil Moisture along Column Length in Column #3 after 4 Weeks of Incubation.....	36
Figure 4-9	Perchlorate, Hydrogen, Nitrate, and Soil Moisture along the Column Length in Column #4 after 8 Weeks of Incubation.....	37
Figure 4-10	Perchlorate, Chlorate, and Nitrate Concentrations in Hydrogen Columns with 10% Soil Moisture after 4 and 10 Weeks of Incubation.....	39

Figure 4-11	Hydrogen, Perchlorate, and Soil Moisture Concentrations in Hydrogen Microcosms with 10% or 16% Soil Moisture after 21 days of Incubation.....	40
Figure 5-1	Effect of Air Injection Flow on Pressure at 120 ft amsl	41
Figure 5-2	Relationship between Distance from Injection Well CDM-INJ1 and Piezometer Pressure at 120 ft amsl	42
Figure 5-3	Effect of Air Flow on Pressure at Piezometer SVS-2.....	43
Figure 5-4	Effect of Air Flow on Pressure at Piezometer CDM-P1.....	43
Figure 5-5	Effect of Air Flow on Pressure at Piezometer SVS-1A.....	43

List of Tables

Table 2-1	Soil Grain Size Analysis Results	7
Table 2-2	Soil Analytical Chemistry Results	13
Table 3-1	Matrix of Experimental Conditions Tested in the Microcosm Experiments	17
Table 3-2	Properties of Tested Electron Donors in Microcosm Tests	17
Table 3-3	Original and Final Conditions of the Aerojet Site Soil after 125-187 Days of Treatment Using Different Electron Donors at 16% Soil Moisture	19
Table 3-4	First Order Perchlorate Degradation Rate Constants, Lag Periods, and Final Perchlorate Concentrations for the Electron Donors Tested in the Microcosm Tests at 16% Soil Moisture	22
Table 3-5	First Order Perchlorate Reduction Rates Observed in the Literature and Their Experimental Conditions	24
Table 3-6	Setup and Results of the 1-day Hydrogen Production Test with the Aerojet Soil at 16% Soil Moisture	27

Acronyms

ASTM	American Society for Testing and Materials
atm-m ³ /mol	atmosphere, meter cubed, per mole
bgs	Below ground surface
C	Concentration
°C	Degrees Celsius
CDM	Camp Dresser & McKee
cfm	Cubic feet per minute
ClO ₄ ⁻	Perchlorate
CMT	Continuous multi-chamber tubing
CO ₂	Carbon dioxide
d	Days
EPA	U. S. Environmental Protection Agency
ESTCP	Environmental Security Technology Certification Program
FID	Flame ionization detector
Ft amsl	Feet above mean sea level
g	Gram
GC	Gas chromatograph
GEDIT	Gaseous electron donor injection technology
h	Hours
H ₂	Hydrogen
Hg	Mercury
IRCTS	Boeing Interactive Rancho Cordova Test Site
k	Average permeability
LAAP	Longhorn Army Ammunition Plant
LPG	Liquified petroleum gas
m ³	Cubic meters
m ³ /day	Cubic meters per day
m/day	Meters per day
mg/kg	Milligrams per kilogram
mL	Milliliters
mm	Millimeters
mM	Millimoles per liter
mmol	Millimoles
mol/L	Moles per liter
msl	Mean sea level
N ₂	Nitrogen
N/kg	Nitrogen per kilogram
NAWQA	National Water Quality Assessment
NO ₂ ⁻	Nitrite
NO ₃ ⁻	Nitrate

O ₂	Oxygen
PBA	Propellant burn area
PID	Photo-ionization detector
ppb	Parts per billion
ppm	Parts per million
P _{sat}	Saturation vapor pressure
psi	Pounds per square inch
PSU	The Pennsylvania State University
PVC	Polyvinyl chloride
Q	Flow rate
TCD	Thermal conductivity detector
TOC	Total organic carbon
TVS	Total volatile solids in the sediments/soils
USA	Underground Service Alert
USCS	Unified Soil Classification System
USEPA	U. S. Environmental Protection Agency
μM	Micrometers
V	Volume
VOC	Volatile organic compound
WDC	Water Development Corporation

1.0 Introduction

The Department of Defense Environmental Security Technology Certification Program (ESTCP) is funding CDM to conduct a demonstration of gaseous electron donor injection technology (GEDIT) for *in situ* bioremediation of perchlorate in soil. CDM and ESTCP have selected the Aerojet Inactive Rancho Cordova Test Site Propellant Burn Area (IRCTS-PBA) as a suitable site for this demonstration. A treatability study was conducted using soil collected from the site to determine engineering design parameters for the demonstration. The treatability study was conducted in accordance the February 14, 2006 Workplan and the September 1, 2006 memorandum Response to Treatability Study Workplan Comments (ER-0511). This treatability study involved the following tasks:

- Completion of two soil borings
- Collection and analysis of soil samples
- Installation of one injection well and one piezometer
- Completion of a perchlorate biodegradation study comprised of microcosm and column tests by The Pennsylvania State University
- Completion of an air injection test

This report presents the methods, results, and conclusions from this treatability study.

2.0 Soil Borings, Lithology, Sample Collection, Sample Analysis Results, and Well Installation

This section presents the methods and procedures that were utilized to drill and install one air injection well (CDM-INJ1) and one multi-level air monitoring well (CDM-P1). The location of the wells is presented on **Figure 2-1**.

2.1 Pre-Field Activities

Drilling and well construction permits were obtained from the County of Sacramento Environmental Management Department prior to drilling. The approved drilling permits are included in **Appendix A-1**. Underground Service Alert (USA) and Aerojet utilities were notified 72 hours prior to drilling to determine the locations of any subsurface utilities.

2.2 Drilling

From July 27, to August 2, 2006, two boreholes were advanced by the Water Development Corporation (WDC) of Woodland, California. Both boreholes were drilled utilizing the sonic drilling method. The injection well (CDM-INJ1) was advanced to a total depth of 70.5 feet below ground surface (bgs) using a 6-inch diameter core barrel and a 10-inch diameter wash-over casing. The monitoring well (CDM-P1) was advanced to a total depth of 72 feet bgs using a 4-inch diameter core barrel and a 6-inch diameter wash-over casing.

The boreholes were continuously cored to total depth by advancing the core barrel in 10-foot increments. As the core barrel was advanced, a continuous core sample was simultaneously collected inside the core barrel. After each 10-foot increment, the temporary wash-over casing was advanced to depth and the core barrel was tripped from the borehole. The core sample was removed from the core barrel and placed in a plastic core bag. This process was repeated until the borehole was advanced to total depth.

The continuous core was logged using the Unified Soil Classification System in accordance to ASTM Standard D2488: Standard Practice for Description and Identification of Soils (Visual-Manual Procedure). The core was logged by a CDM field geologist under the supervision of a State of California, Professional Geologist. The log included a description of the materials encountered during drilling and noting zones impacted of visual contamination. Additionally, the core was screened for volatile organic compounds using a photo-ionization detector (PID) by placing a portion of the core in a zip-lock sealed bag. After approximately five to 10 minutes, the zip-lock bag was punctured with a small hole and the tip of the PID was inserted into the bag to assess the head space in the bag for volatile organic compounds. The measurements were recorded on the boring log. The boring logs are presented in **Appendix A-2**.

Soil samples were collected from the continuous core and placed in sample containers. As required, some of the samples were placed on ice. Samples were submitted to the CDM laboratory in Bellevue, Washington; Laucks Testing Labs (Laucks) in Seattle, Washington; and The Pennsylvania State University (PSU) in University Park, Pennsylvania under chain-of-custody protocol.

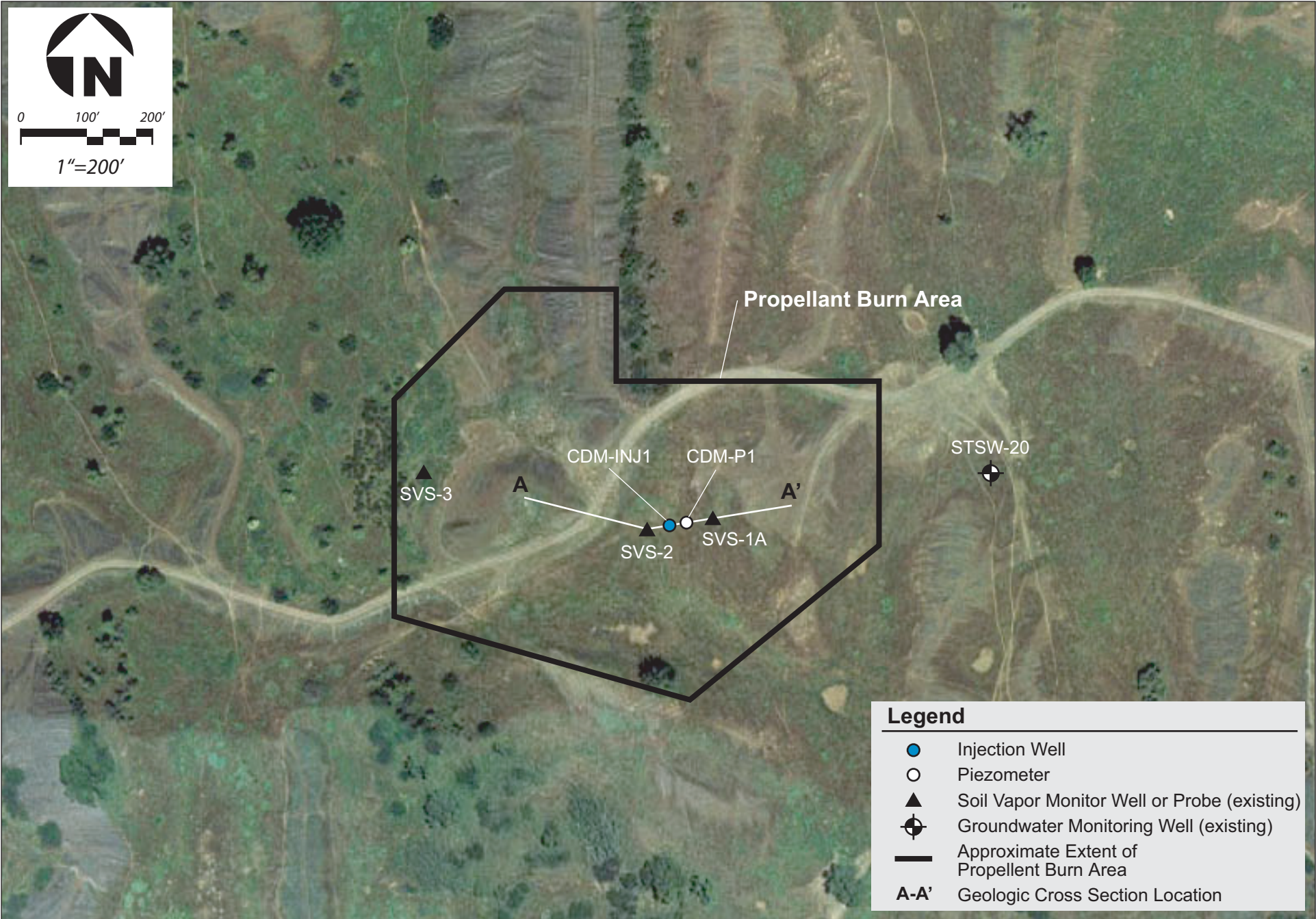

W:\REPORTS\Aerjet\IRCTS Test Site Report_Feb06\Inactive Rancho Cordova Test Site(Fig2-1).ai 02/10/06 JJT

Figure 2-1
Proposed Locations of
Soil Borings/Pilot Test Wells
Propellant Burn Area

Soil samples were collected and submitted to the laboratory for analysis from the core of each boring at 5-foot intervals from the 5-foot to 70-foot depth. The samples submitted to the CDM laboratory were analyzed for perchlorate using a perchlorate ion-selective probe following extraction with an equal weight of water in accordance with the Workplan, and moisture by ASTM Method D2216. The samples submitted to Laucks were analyzed for perchlorate by EPA Method 314.1, nitrate and nitrite as nitrogen by EPA Method 353.2, total organic carbon (TOC) by EPA Method 415.1 modified for soil, moisture by ASTM Method D2216, pH by Standard Method number 9045-C, and grain size by ASTM D422. The samples submitted to the Pennsylvania State University (PSU) were used for a perchlorate bioremediation study as described in Section 3.

2.3 Well Construction

Upon reaching total depth of the borehole, an air injection well was installed in CDM-INJ1 and a multi-level air monitoring well was installed in CDM-P1. CDM-INJ1 was installed as an air injection location. CDM-P1 was installed as a monitoring point to assess the extent of influence of the injection air. The as-built construction details of the wells are shown on **Figure 2-2 and 2-3**.

The injection well CDM-INJ1 was constructed with a 6-inch diameter schedule 40 PVC well casing with flush-threaded joints (**Figure 2-2**). The well screen consisted of a 6-inch diameter schedule 40 PVC machine slotted pipe with a total of 60 feet of 0.020-inch slotted screen. The screen was installed between 10 and 70 feet bgs. The filter pack consisted of Number 3 sand sealed with a bentonite pellet seal. The annular space above the bentonite pellet seal was sealed with a cement bentonite grout. The well was completed in an above grade monument.



The monitoring well CDM-P1 was constructed with four nested wells completed at different depths. Each well was constructed with a 0.25-inch diameter polyurethane tubing (**Figure 2-3**). Each well was completed with a 0.25-inch diameter, 6-inch long stainless steel vapor probe. The vapor probes were installed at depths of 18, 33, 48, and 68 feet bgs. The filter pack placed in the annular space around each probe consisted of Number 3 Monterey sand. The annular space above and below the filter pack was sealed with a benonite chip seal. The annular space above the uppermost bentonite seal was sealed with a cement bentonite grout. The multi-port well was completed in an above grade monument.

The wells were not developed because water was not used during drilling and groundwater was not encountered during drilling.

2.4 Decontamination

All field equipment including the drill rig and downhole tools were cleaned and decontaminated prior to being introduced into the drilling and sampling environment. The equipment and downhole tools were decontaminated by steam cleaning or washing in a solution of non-phosphate detergent followed by a double rinse of clean water.

LEGEND

-  CEMENT BENTONITE GROUT SEAL
-  BENTONITE CHIP SEAL
-  NO. 3 MONTEREY SAND

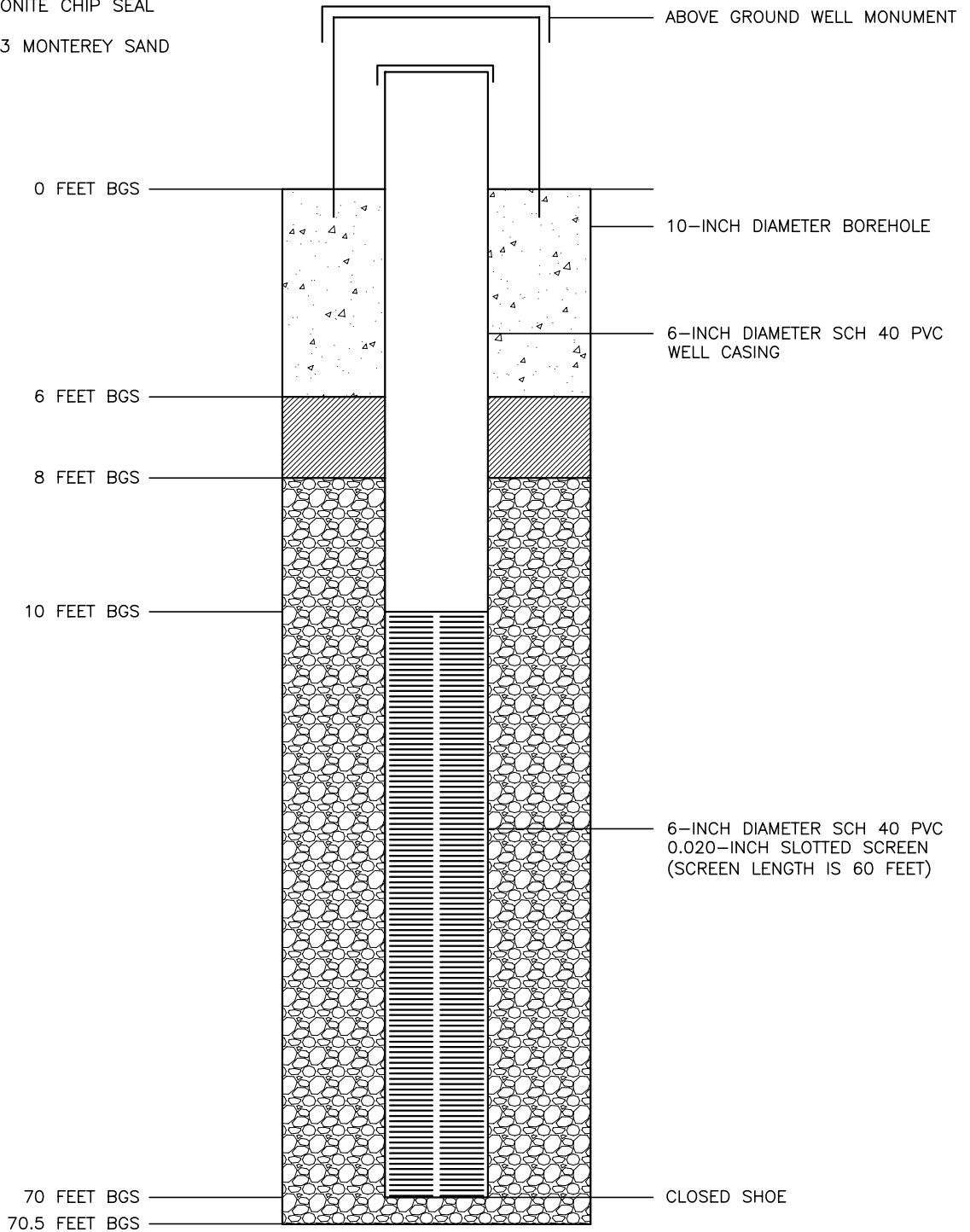

NOT TO SCALE

FIGURE 2-X
AS-BUILT WELL DETAIL
CDM-INJI
GEDIT-AEROJET

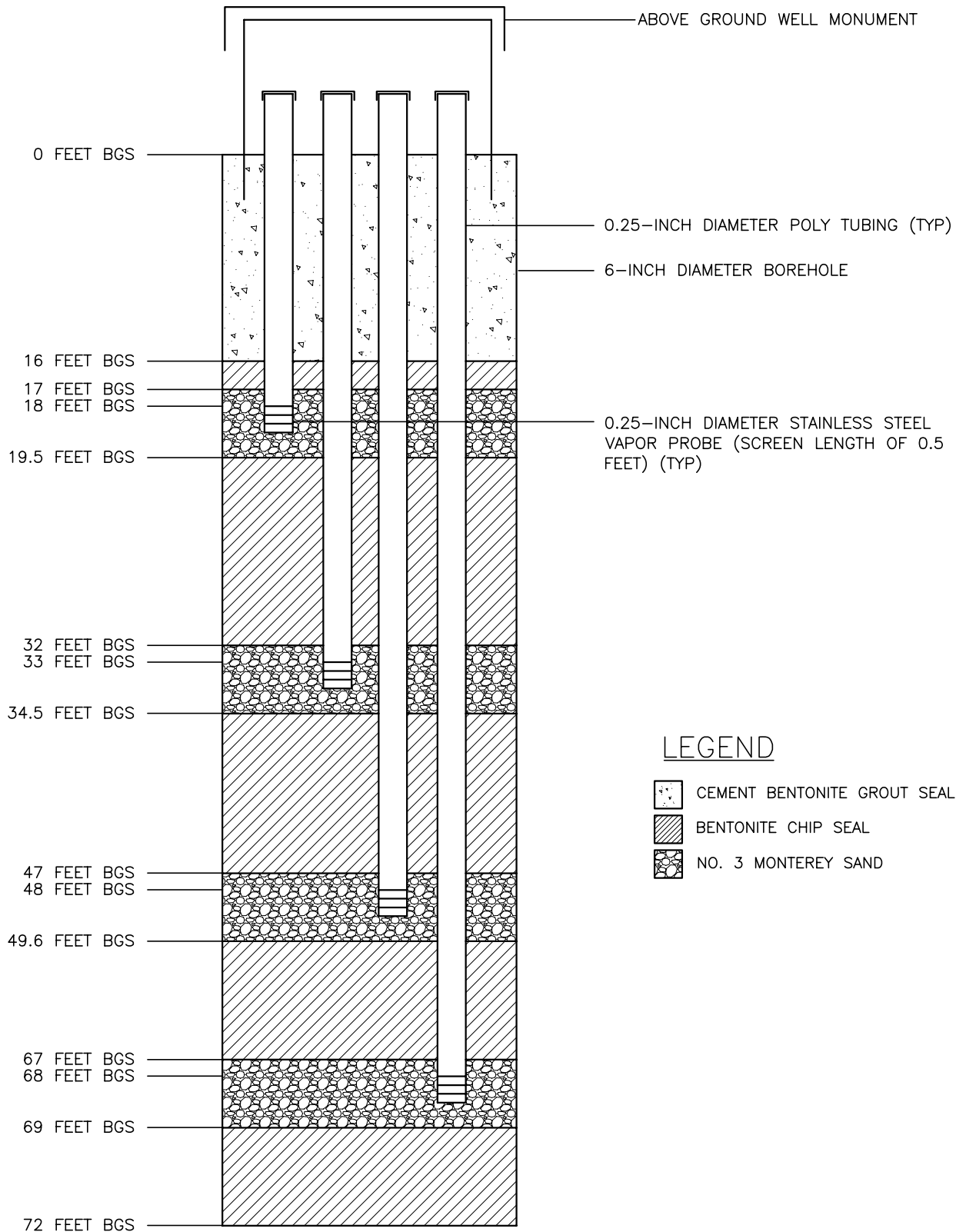

NOT TO SCALE

FIGURE 2-X
 AS-BUILT WELL DETAIL
 CDM-PI
 GEDIT-AEROJET

2.5 Lithology

The lithology encountered during drilling ranged from silt and clay to silty sand and clayey gravel to cobbles. No soil discoloration or odors were observed in the drill cuttings from either boring. All of the PID readings were non-detect. No groundwater was encountered in any formations during drilling. A detailed description of the soils encountered in each borehole is presented on the boring logs (**Appendix A-2**). **Table 2-1** and **Figures 2-4** and **2-5** show the grain size distribution for soils encountered during boring completion and **Figure 2-6** shows a lithologic cross-section based on these data and existing data (Aerojet, 2000). These data indicate that soil is generally coarse-grained and supportive of gas injection with the exception of shallow soil (i.e., 15 ft bgs) in boring CDM-INJ1.

Table 2-1 Soil Grain Size Analysis Results

Well	Date	Depth	Sample Type	Sieve Slot Size (mm)	Weight Retained (grams)	Cumulative Retained (%)
CDM-INJ1	7/31/2006	15	Sample	< 0.075	77	77
CDM-INJ1	7/31/2006	15	Sample	0.075	18	95
CDM-INJ1	7/31/2006	15	Sample	0.106	4.4	99.4
CDM-INJ1	7/31/2006	15	Sample	0.25	0.4	99.8
CDM-INJ1	7/31/2006	15	Sample	0.425	0.1	99.9
CDM-INJ1	7/31/2006	15	Sample	0.85	0.2	100.1
CDM-INJ1	7/31/2006	15	Sample	2	0	100.1
CDM-INJ1	7/31/2006	15	Sample	4.75	0	100.1
CDM-INJ1	7/31/2006	15	Sample	9.5	0	100.1
CDM-INJ1	7/31/2006	15	Sample	19	0	100.1
CDM-INJ1	7/31/2006	15	Sample	25	0	100.1
CDM-INJ1	7/31/2006	15	Sample	37.5	0	100.1
CDM-INJ1	7/31/2006	15	Sample	50	0	100.1
CDM-INJ1	7/31/2006	20	Sample	< 0.075	30	30
CDM-INJ1	7/31/2006	20	Sample	0.075	9	39
CDM-INJ1	7/31/2006	20	Sample	0.106	31	70
CDM-INJ1	7/31/2006	20	Sample	0.25	14	84
CDM-INJ1	7/31/2006	20	Sample	0.425	16	100
CDM-INJ1	7/31/2006	20	Sample	0.85	0	100
CDM-INJ1	7/31/2006	20	Sample	2	0	100
CDM-INJ1	7/31/2006	20	Sample	4.75	0	100
CDM-INJ1	7/31/2006	20	Sample	9.5	0	100
CDM-INJ1	7/31/2006	20	Sample	19	0	100
CDM-INJ1	7/31/2006	20	Sample	25	0	100
CDM-INJ1	7/31/2006	20	Sample	37.5	0	100
CDM-INJ1	7/31/2006	20	Sample	50	0	100
CDM-INJ1	7/31/2006	35	Sample	< 0.075	5.2	5.2
CDM-INJ1	7/31/2006	35	Sample	0.075	2.1	7.3
CDM-INJ1	7/31/2006	35	Sample	0.106	11	18.3
CDM-INJ1	7/31/2006	35	Sample	0.25	4.9	23.2
CDM-INJ1	7/31/2006	35	Sample	0.425	6.5	29.7
CDM-INJ1	7/31/2006	35	Sample	0.85	7.5	37.2
CDM-INJ1	7/31/2006	35	Sample	2	13	50.2
CDM-INJ1	7/31/2006	35	Sample	4.75	15	65.2
CDM-INJ1	7/31/2006	35	Sample	9.5	30	95.2
CDM-INJ1	7/31/2006	35	Sample	19	6	101.2
CDM-INJ1	7/31/2006	35	Sample	25	0	101.2

Table 2-1 Soil Grain Size Analysis Results (cont.)

Well	Date	Depth	Sample Type	Sieve Slot Size (mm)	Weight Retained (grams)	Cumulative Retained (%)
CDM-INJ1	7/31/2006	35	Sample	37.5	0	101.2
CDM-INJ1	7/31/2006	35	Sample	50	0	101.2
CDM-INJ1	7/31/2006	50	Sample	< 0.075	14	14
CDM-INJ1	7/31/2006	50	Sample	0.075	8.1	22.1
CDM-INJ1	7/31/2006	50	Sample	0.106	22	44.1
CDM-INJ1	7/31/2006	50	Sample	0.25	13	57.1
CDM-INJ1	7/31/2006	50	Sample	0.425	18	75.1
CDM-INJ1	7/31/2006	50	Sample	0.85	9.7	84.8
CDM-INJ1	7/31/2006	50	Sample	2	7.8	92.6
CDM-INJ1	7/31/2006	50	Sample	4.75	7.9	100.5
CDM-INJ1	7/31/2006	50	Sample	9.5	0	100.5
CDM-INJ1	7/31/2006	50	Sample	19	0	100.5
CDM-INJ1	7/31/2006	50	Sample	25	0	100.5
CDM-INJ1	7/31/2006	50	Sample	37.5	0	100.5
CDM-INJ1	7/31/2006	50	Sample	50	0	100.5
CDM-INJ1	7/31/2006	70	Sample	< 0.075	5.6	5.6
CDM-INJ1	7/31/2006	70	Sample	0.075	3.4	9
CDM-INJ1	7/31/2006	70	Sample	0.106	9.1	18.1
CDM-INJ1	7/31/2006	70	Sample	0.25	5.5	23.6
CDM-INJ1	7/31/2006	70	Sample	0.425	9.7	33.3
CDM-INJ1	7/31/2006	70	Sample	0.85	7.4	40.7
CDM-INJ1	7/31/2006	70	Sample	2	11	51.7
CDM-INJ1	7/31/2006	70	Sample	4.75	13	64.7
CDM-INJ1	7/31/2006	70	Sample	9.5	15	79.7
CDM-INJ1	7/31/2006	70	Sample	19	20	99.7
CDM-INJ1	7/31/2006	70	Sample	25	0	99.7
CDM-INJ1	7/31/2006	70	Sample	37.5	0	99.7
CDM-INJ1	7/31/2006	70	Sample	50	0	99.7
CDM-INJ1	7/31/2006	70	Duplicate	< 0.075	7	7
CDM-INJ1	7/31/2006	70	Duplicate	0.075	6	13
CDM-INJ1	7/31/2006	70	Duplicate	0.106	9.5	22.5
CDM-INJ1	7/31/2006	70	Duplicate	0.25	5.7	28.2
CDM-INJ1	7/31/2006	70	Duplicate	0.425	13	41.2
CDM-INJ1	7/31/2006	70	Duplicate	0.85	14	55.2
CDM-INJ1	7/31/2006	70	Duplicate	2	15	70.2
CDM-INJ1	7/31/2006	70	Duplicate	4.75	6	76.2
CDM-INJ1	7/31/2006	70	Duplicate	9.5	30	106.2
CDM-INJ1	7/31/2006	70	Duplicate	19	0	106.2
CDM-INJ1	7/31/2006	70	Duplicate	25	0	106.2
CDM-INJ1	7/31/2006	70	Duplicate	37.5	0	106.2
CDM-INJ1	7/31/2006	70	Duplicate	50	0	106.2
CDM-P1	7/27/2006	15	Sample	< 0.075	8	8
CDM-P1	7/27/2006	15	Sample	0.075	3.8	11.8
CDM-P1	7/27/2006	15	Sample	0.106	14	25.8
CDM-P1	7/27/2006	15	Sample	0.25	6.7	32.5
CDM-P1	7/27/2006	15	Sample	0.425	10	42.5
CDM-P1	7/27/2006	15	Sample	0.85	14	56.5
CDM-P1	7/27/2006	15	Sample	2	25	81.5
CDM-P1	7/27/2006	15	Sample	4.75	19	100.5

Table 2-1 Soil Grain Size Analysis Results (cont.)

Well	Date	Depth	Sample Type	Sieve Slot Size (mm)	Weight Retained (grams)	Cumulative Retained (%)
CDM-P1	7/27/2006	15	Sample	9.5	0	100.5
CDM-P1	7/27/2006	15	Sample	19	0	100.5
CDM-P1	7/27/2006	15	Sample	25	0	100.5
CDM-P1	7/27/2006	15	Sample	37.5	0	100.5
CDM-P1	7/27/2006	15	Sample	50	0	100.5
CDM-P1	7/27/2006	25	Sample	< 0.075	3.3	3.3
CDM-P1	7/27/2006	25	Sample	0.075	1.4	4.7
CDM-P1	7/27/2006	25	Sample	0.106	4.7	9.4
CDM-P1	7/27/2006	25	Sample	0.25	2.4	11.8
CDM-P1	7/27/2006	25	Sample	0.425	3.8	15.6
CDM-P1	7/27/2006	25	Sample	0.85	11	26.6
CDM-P1	7/27/2006	25	Sample	2	22	48.6
CDM-P1	7/27/2006	25	Sample	4.75	15	63.6
CDM-P1	7/27/2006	25	Sample	9.5	31	94.6
CDM-P1	7/27/2006	25	Sample	19	5.5	100.1
CDM-P1	7/27/2006	25	Sample	25	0	100.1
CDM-P1	7/27/2006	25	Sample	37.5	0	100.1
CDM-P1	7/27/2006	25	Sample	50	0	100.1
CDM-P1	7/27/2006	25	Sample	< 0.075	10	10
CDM-P1	7/27/2006	35	Sample	0.075	5.3	15.3
CDM-P1	7/27/2006	35	Sample	0.106	16	31.3
CDM-P1	7/27/2006	35	Sample	0.25	5.6	36.9
CDM-P1	7/27/2006	35	Sample	0.425	8	44.9
CDM-P1	7/27/2006	35	Sample	0.85	15	59.9
CDM-P1	7/27/2006	35	Sample	2	18	77.9
CDM-P1	7/27/2006	35	Sample	4.75	15	92.9
CDM-P1	7/27/2006	35	Sample	9.5	8.1	101
CDM-P1	7/27/2006	35	Sample	19	0	101
CDM-P1	7/27/2006	35	Sample	25	0	101
CDM-P1	7/27/2006	35	Sample	37.5	0	101
CDM-P1	7/27/2006	35	Sample	50	0	101
CDM-P1	7/27/2006	45	Sample	< 0.075	7	7
CDM-P1	7/27/2006	45	Sample	0.075	4.1	11.1
CDM-P1	7/27/2006	45	Sample	0.106	14	25.1
CDM-P1	7/27/2006	45	Sample	0.25	15	40.1
CDM-P1	7/27/2006	45	Sample	0.425	38	78.1
CDM-P1	7/27/2006	45	Sample	0.85	21	99.1
CDM-P1	7/27/2006	45	Sample	2	1.8	100.9
CDM-P1	7/27/2006	45	Sample	4.75	0	100.9
CDM-P1	7/27/2006	45	Sample	9.5	0	100.9
CDM-P1	7/27/2006	45	Sample	19	0	100.9
CDM-P1	7/27/2006	45	Sample	25	0	100.9
CDM-P1	7/27/2006	45	Sample	37.5	0	100.9
CDM-P1	7/27/2006	45	Sample	50	0	100.9
CDM-P1	7/27/2006	70	Sample	< 0.075	9.4	9.4
CDM-P1	7/27/2006	70	Sample	0.075	4.6	14
CDM-P1	7/27/2006	70	Sample	0.106	13	27
CDM-P1	7/27/2006	70	Sample	0.25	9.6	36.6
CDM-P1	7/27/2006	70	Sample	0.425	17	53.6

Table 2-1 Soil Grain Size Analysis Results (cont.)

Well	Date	Depth	Sample Type	Sieve Slot Size (mm)	Weight Retained (grams)	Cumulative Retained (%)
CDM-P1	7/27/2006	70	Sample	0.85	8.2	61.8
CDM-P1	7/27/2006	70	Sample	2	2.8	64.6
CDM-P1	7/27/2006	70	Sample	4.75	2.1	66.7
CDM-P1	7/27/2006	70	Sample	9.5	20	86.7
CDM-P1	7/27/2006	70	Sample	19	14	100.7
CDM-P1	7/27/2006	70	Sample	25	0	100.7
CDM-P1	7/27/2006	70	Sample	37.5	0	100.7
CDM-P1	7/27/2006	70	Sample	50	0	100.7

Notes:

bgs = below ground surface
mm = millimeters

Figure 2-4 CDM-INJ1 Grain Size Distribution

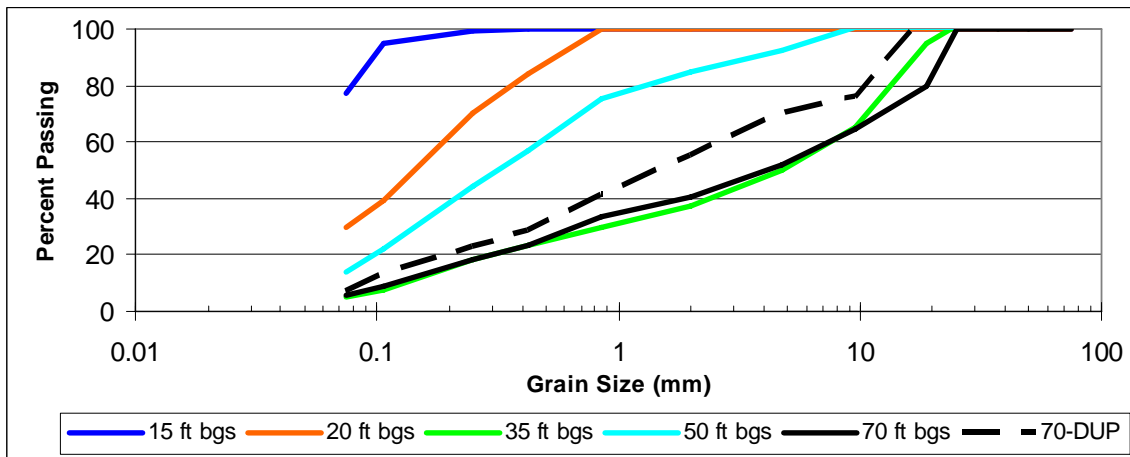
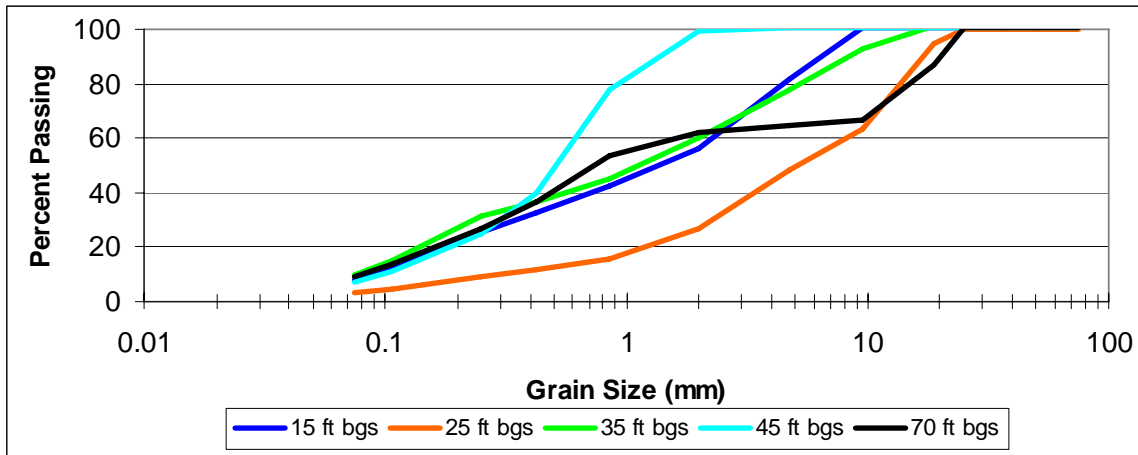
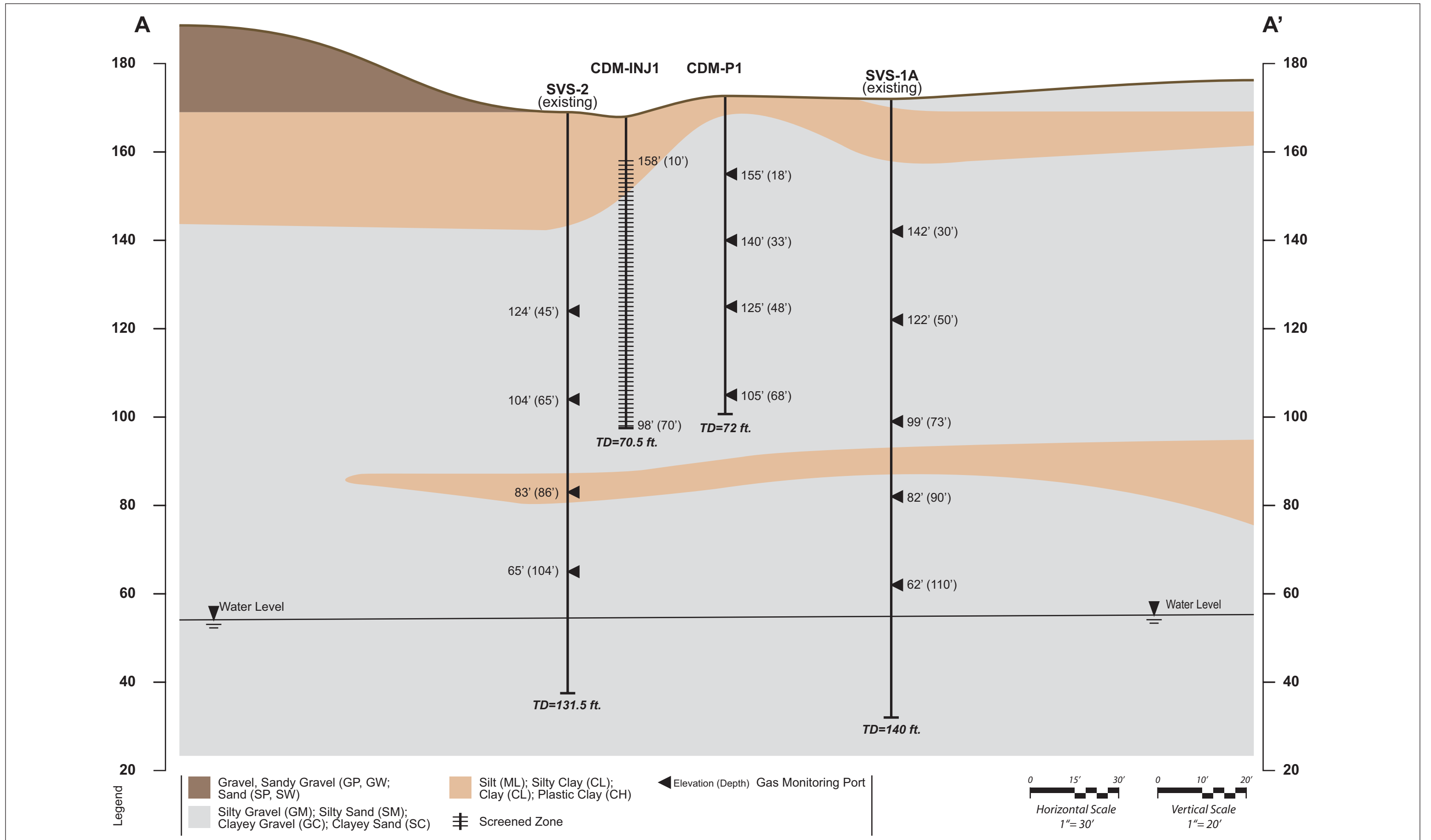

Figure 2-5 CDM-P1 Grain Size Distribution





C:\Users\Tlust\Aerjet\Generalized Lithologic Cross Section(FigX-X).ai 10/11/06 AVS

Source: Remedial Investigation Report for the Vapor Zone at the Propellant Burn Area, Inactive Rancho Cordova Test Site
 HSI GEOTRANS, Inc., May 2000



Figure 2-6

Generalized Lithologic Cross Section
 GEDIT Air-Injection Pilot Test

2.6 Analytical Chemistry

The results for soil samples that were collected are presented in **Table 2-2**. Data for perchlorate, nitrate/nitrite, and moisture are graphically presented in **Figures 2-7** and **2-8**.

For soil from boring CDM-INJ1, the data indicate that nitrate/nitrite concentrations were less than 5 mg-N/kg and perchlorate ranged from 3.7 to 59 mg/kg based on field screening analyses. Field screening results generally correlated to laboratory confirmatory analyses. Perchlorate was present in greater concentrations at shallower depths and was associated with the finer grained soils based on comparison to **Figure 2-4**. Greater concentrations of perchlorate were also associated with greater moisture contents. The maximum moisture content in soil from CDM-INJ1 was 34 percent and the minimum moisture content was 6.5 percent.

For soil from boring CDM-P1, nitrate/nitrite concentrations were similar but perchlorate was nondetectable at shallow depths and ranged from 0.45 to 9.8 mg/kg at greater depths. Field screening results for perchlorate correlated generally well with laboratory results except at concentrations near the limit of detection for the ion-selective probe (about 0.2 mg/kg). Moisture ranged from 6.9 to 18 percent. For soil from both borings, soil moisture ranged from 6.9 to 16 percent in the more permeable soils (i.e., not silt or clay).

Total organic carbon (TOC) was generally nondetectable or near the limit of detection (0.2 to 0.3 mg/kg) and pH ranged from 6.9 to 8.1.

Table 2-2 Soil Analytical Chemistry Results

Well	Date	Depth (bgs)	Sample Type	CDM Analysis				Laucks Analysis							
				Perchlorate (mg/kg)	Moisture (%)	USCS	Moisture Non-Clay Silt	Perchlorate (mg/kg)	Difference (%)	Moisture (%)	Difference (%)	pH	Nitrate & Nitrite as Nitrogen (mg/kg)	TOC (%)	Total Solids (%)
CDM-P1	7/27/2006	5	sample	0.15	18.1	ML	--	--	--	--	--	--	--	--	--
CDM-P1	7/27/2006	5	duplicate	0.12	--	ML	--	--	--	--	--	--	--	--	--
CDM-P1	7/27/2006	10	sample	0.17	7.5	GM	7.5	--	--	--	--	--	--	--	--
CDM-P1	7/27/2006	15	sample	0.12	8.4	GM	8.4	< 0.011	991.0	10.1	-16.0	8.1	3.2	< .21	89.9
CDM-P1	7/27/2006	15	duplicate	--	8.3	GM	--	--	--	--	--	--	--	--	--
CDM-P1	7/27/2006	20	sample	0.079	9.4	GM	9.4	--	--	--	--	--	--	--	--
CDM-P1	7/27/2006	25	sample	0.45	9.0	GC	9.0	1.3	-65.0	12.6	-29.0	7.7	4	< .23	87.4
CDM-P1	7/27/2006	30	sample	0.45	7.5	GC	7.5	--	--	--	--	--	--	--	--
CDM-P1	7/27/2006	35	sample	0.69	6.9	GC/SP	6.9	5	-86.0	6.9	0.0	7.8	1.8	<.21	93.1
CDM-P1	7/27/2006	40	sample	3.6	13.9	GC	13.9	--	--	--	--	--	--	--	--
CDM-P1	7/27/2006	45	sample	7.3	9.5	GC/SM	9.5	8.5	-14.0	10.8	-12.0	7.5	2.2	0.24	89.2
CDM-P1	7/27/2006	50	sample	9.0	11.8	SM	11.8	--	--	--	--	--	--	--	--
CDM-P1	7/27/2006	55	sample	6.2	12.0	SM	12.0	--	--	--	--	--	--	--	--
CDM-P1	7/27/2006	55	duplicate	--	10.7	SM	--	--	--	--	--	--	--	--	--
CDM-P1	7/27/2006	60	sample	5.0	7.1	SM	7.1	--	--	--	--	--	--	--	--
CDM-P1	7/27/2006	65	sample	3.2	15.9	SC/SM	15.9	--	--	--	--	--	--	--	--
CDM-P1	7/27/2006	65	duplicate	3.1	--	SC/SM	--	--	--	--	--	--	--	--	--
CDM-P1	7/27/2006	70	sample	9.8	13.3	SM	13.3	12	-18.0	16.7	-20.0	7.4	1.3	<.22	83.3
CDM-INJ1	7/31/2006	5	sample	59	25.7	ML	--	--	--	--	--	--	--	--	--
CDM-INJ1	7/31/2006	10	sample	49	32.9	ML/CL	--	--	--	--	--	--	--	--	--
CDM-INJ1	7/31/2006	15	sample	30	18.5	ML	--	41	-27.0	19.9	-7.0	7	5.2	0.34	80.1
CDM-INJ1	7/31/2006	20	sample	58	34.3	CL/GC	--	73	-21.0	34.6	-1.0	6.9	10	<.3	65.4
CDM-INJ1	7/31/2006	25	sample	18	13.2	GC/SM	13.2	--	--	--	--	--	--	--	--
CDM-INJ1	7/31/2006	30	sample	10	10.2	SM	10.2	--	--	--	--	--	--	--	--
CDM-INJ1	7/31/2006	35	sample	5.6	11.2	SM	11.2	17	-67.0	13.7	-18.0	7.6	2.3	<.23	86.3
CDM-INJ1	7/31/2006	40	sample	6.7	11.9	SM	11.9	--	--	--	--	--	--	--	--
CDM-INJ1	7/31/2006	45	sample	4.9	7.9	SM	7.9	--	--	--	--	--	--	--	--
CDM-INJ1	7/31/2006	45	duplicate	4.2	--	SM	--	--	--	--	--	--	--	--	--
CDM-INJ1	7/31/2006	50	sample	5.6	8.8	SM	8.8	7.7	-27.0	13.2	-33.0	7.8	2.2	<.22	86.8
CDM-INJ1	7/31/2006	55	sample	4.6	7.6	SM	7.6	--	--	--	--	--	--	--	--
CDM-INJ1	7/31/2006	60	sample	4.1	7.4	SM	7.4	--	--	--	--	--	--	--	--
CDM-INJ1	7/31/2006	65	sample	3.7	6.5	SM	6.5	--	--	--	--	--	--	--	--
CDM-INJ1	7/31/2006	70	sample	4.1	6.5	SM	6.5	5.7	-28.0	7.8	-17.0	7.7	1.6	<.21	92.2
CDM-INJ1	7/31/2006	70	duplicate	--	7.5	SM	--	--	--	8	-0.1	7.7	--	--	0.9

Notes:

bgs = below ground surface

mg/kg = milligrams per kilogram

<20 = Not detected at indicated detection limit

TOC = Total organic

-- = Not analyzed

ML = silt

GM = silty

GL = clayey

SP = poorly graded sand

SL = clayey sand

SM = silty sand

CL = clay

Figure 2-7 CDM-INJ1 Contaminant and Moisture Distribution

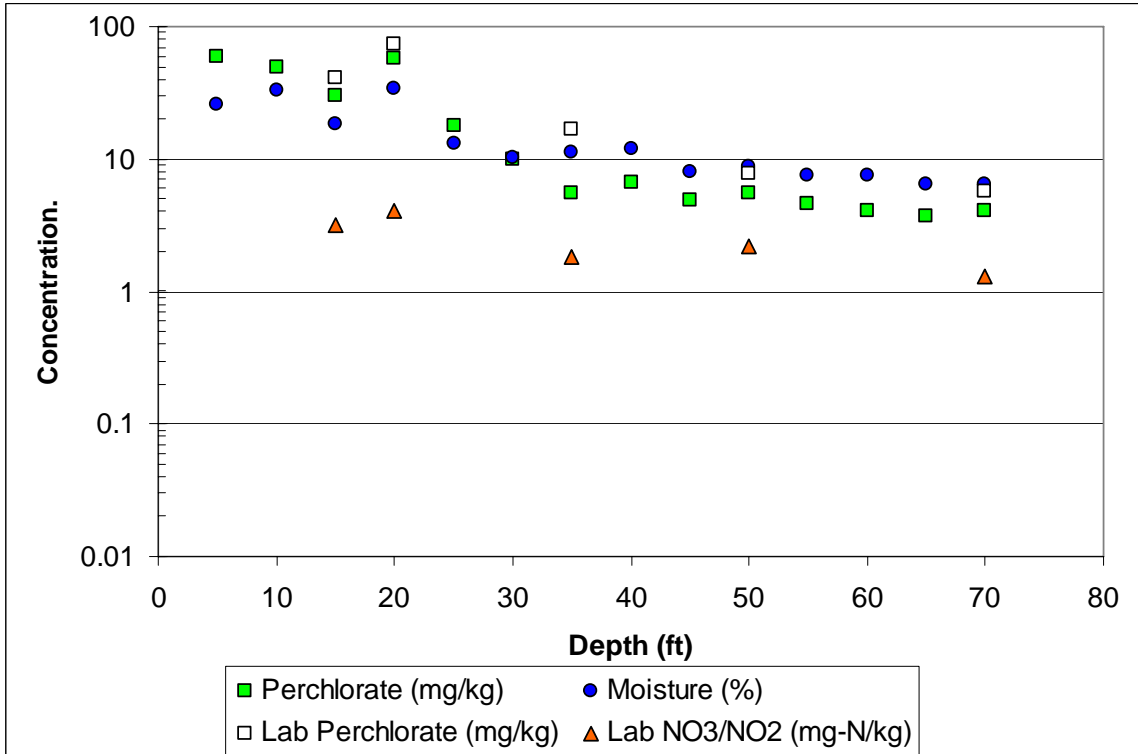
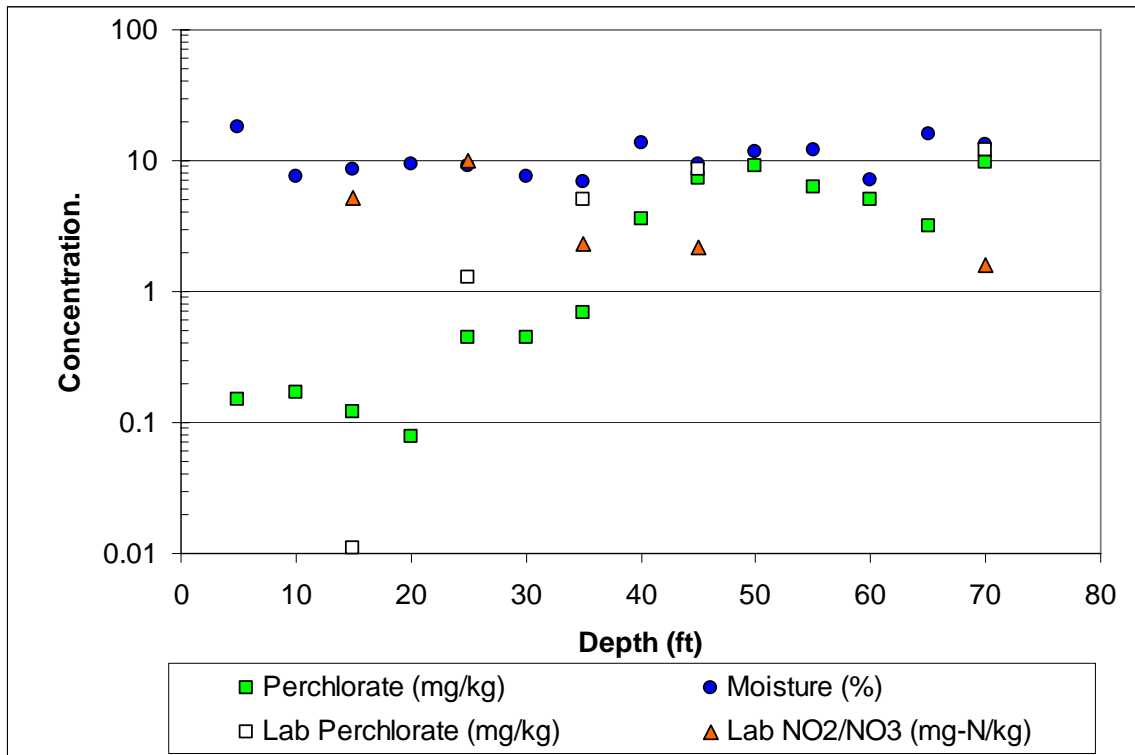

Figure 2-8 CDM-P1 Contaminant and Moisture Distribution



3.0 Microcosm Tests

3.1 Abstract

Sacrificial batch microcosm tests were used to rapidly assess the ability of gaseous electron donors and various moisture contents to achieve optimal perchlorate remediation in vadose zone soil taken from the Aerojet Propellant Burn Area site in California. The electron donor candidates tested were hydrogen, 1-hexene, ethyl acetate, and liquefied petroleum gas (LPG) also known as propane. Each electron donor was tested at two different concentrations under two different soil moisture contents that were representative of minimum and maximum site moisture contents at the site. No perchlorate reduction occurred in low moisture (7%) bottles after an incubation time of 125-187 days, and all bottles except ethyl acetate achieved complete or partial perchlorate reduction in high moisture (16%) bottles. Results from these microcosm tests indicate that hydrogen is the most promising of the tested electron donors for the treatment of perchlorate in vadose zone soil, achieving complete perchlorate degradation within 35-42 days, with a perchlorate reduction rate of 0.1327-0.1894 d⁻¹. LPG promoted complete perchlorate reduction at the high LPG dose and 1-hexene promoted partial perchlorate reduction at both doses; however, when compared to hydrogen, these donors had more significant lag periods of 21 - 49 days and lower perchlorate reduction rates of 0.0083-0.0326 d⁻¹ and 0.0079-0.0161 d⁻¹, respectively.

3.2 Materials and Methods

3.2.1 Soil Characterization

The soil used in this test was collected using sonic drilling methods from the site and shipped to The Pennsylvania State University in six 5-gallon buckets in August 4, 2006. The day after arrival, the soil was processed as follows. After removing large stones by hand and passing the soil through a ½ inch sieve, all of the soil was well mixed together in a large container and then transferred to four buckets, sealed, and stored at room temperature. The following day, duplicate grab samples were taken from each bucket and tested for perchlorate, nitrate, pH, and soil moisture. The resulting standard deviation of perchlorate concentration was approximately 41% of the average concentration, so the soil was remixed and redistributed to four buckets again and retested for perchlorate, nitrate, pH, and soil moisture, as well as for total nitrogen and total carbon. The remaining soil was stored at room temperature in the sealed buckets for 10 days until the experiments were performed.

3.2.2 Experimental Design and Setup

The microcosm tests were performed in a standard statistical factorial design (**Table 3-1**). Soil moisture content, electron donor type, and electron donor concentration were the variables evaluated in the test. According to the lowest and highest moisture level naturally present at the field site, the moisture contents tested were 7 and 16%. The electron donors tested were hydrogen, ethyl acetate, 1-hexene, and commercial liquid petroleum gas (LPG), the main component of which is propane. These electron donors were selected because of their high vapor pressures and high Henry's constants (**Table 3-2**), making them well-suited to transport in the vadose zone. Low and high electron donor concentrations were designed to be three and ten

times the quantity required to stoichiometrically reduce all of the oxygen, nitrate, and perchlorate present in the soil. The concentrations listed in Table 3-1 reflect these stoichiometric calculations based on the actual nitrate and perchlorate concentrations, and conservatively assume that the entire headspace is air. A negative control containing no electron donor and a positive control containing ethanol, which was previously shown by CDM to give positive perchlorate degradation results, were also tested.

For each test condition shown in **Table 3-1**, nine replicate bottles were established to enable periodic sacrificial analysis of the soil, and half of the active tests (tests 1, 2, 6, 7, 11, 12, 13, and 16) were randomly selected to be run in duplicate. To setup the 234 microcosms, soil from the field site was transferred in 10-gram (g) aliquots to 150-mL glass serum bottles. After the bottles were sealed with thick butyl rubber stoppers and aluminum crimp tops, the gas in the bottles was purged with 10-psi ultra-high purity nitrogen gas for at least 15 minutes to remove oxygen and maintain anoxic conditions. Ten percent (10%) of the bottles were randomly chosen for headspace oxygen analysis. Greater than 1% oxygen was detected in one of the bottles in the Test 5 set, so all nine bottles in Test 5 were re-purged with nitrogen, retested for oxygen, and passed. After degassing all of the bottles, one of the candidate electron donors and de-ionized water were injected into the bottles to achieve the desired test conditions. During the injection, liquid electron donors (ethyl acetate and 1-hexene) were dropped onto the wall of the bottles and allowed to completely vaporize into the gaseous phase rather than injecting the electron donor liquid directly onto the soil. Prior to injecting the gaseous electron donors (hydrogen and LPG), an equivalent volume of nitrogen gas was withdrawn from the bottles to avoid increasing pressure. Carbon dioxide at 748 and 2508 mg/kg was added as a carbon source to microcosms containing hydrogen. The amount of carbon dioxide needed in the hydrogen microcosms was conservatively assumed to be half of the electron donor concentration (in mol/L), in order to ensure that lack of carbon would not be a limiting factor for bioremediation. See **Appendix A-3** for additional details about the microcosm setup.

The total setup time for all 234 bottles was 48 days (extended due to an instrumentation problem) during which time the bottles were stored at room temperature on the open bench. After adding the electron donor and shaking to facilitate homogeneous headspace-soil contact, the first bottle of each test condition was sacrificed immediately as the time zero measurement. The remaining bottles were incubated in the dark at room temperature for a total of two to three months and were shaken about 3 times per week to help gaseous electron donor distribution and increase headspace-soil contact.

Table 3-1 Matrix of Experimental Conditions Tested in the Microcosm Experiments

Test Number	Electron Donor	Electron donor concentration (mg/kg soil)	Soil moisture
1	H ₂ (+CO ₂)	34 (+374)	7%
2	Ethyl acetate	150	7%
3	1-Hexene	80	7%
4	LPG	75	7%
5	H ₂ (+CO ₂)	114 (+1254)	7%
6	Ethyl acetate	501	7%
7	1-Hexene	165	7%
8	LPG	250	7%
9	H ₂ (+CO ₂)	34 (+374)	16%
10	Ethyl acetate	150	16%
11	1-Hexene	80	16%
12	LPG	75	16%
13	H ₂ (+CO ₂)	114 (+1254)	16%
14	Ethyl acetate	501	16%
15	1-Hexene	165	16%
16	LPG	250	16%
17	Negative Control	0	16%
18	Positive Control	436 (Ethanol)	16%

Table 3-2 Properties of Tested Electron Donors in Microcosm Tests

Electron donor Candidates	Molecular formula	Formula weight (g/mol)	H (atm·m ³ /mol)	P _{sat} (mm Hg)
Hydrogen	H ₂	2	1.28E+00	760
Ethyl Acetate	CH ₃ CH ₂ COOCH ₃	88.11	1.34E-04	60
1-Hexene	CH ₃ (CH ₂) ₃ CHCH ₂	84.16	4.17E-01	100
LPG (Liquefied Petroleum Gas, 90% propane)	CH ₃ CH ₂ CH ₃	44.1	6.00E-01	5700
Ethanol	C ₂ H ₅ OH	46.07	5.00E-06	40

During the incubation, one of the replicates of each test condition was analyzed every one to four weeks, the frequency depending on the observed rate of perchlorate degradation. During the analysis process, the headspace electron donor concentration, O₂, and CO₂ were tested first, and then the bottles were sacrificed (i.e., opened) to test the soil for perchlorate, nitrate, nitrite,

chlorate, chlorite, and chloride concentration, moisture content, and pH. Between every two sampling points, the concentration of electron donor in the headspace was tested weekly.

3.2.3 Chemical Analyses

An Agilent model 6890N gas chromatograph (GC) equipped with a DB-624 column and a flame ionization detector (FID) was used to test the electron donors (ethyl acetate, 1-hexene, propane, and ethanol). Headspace samples (1000 μ L) were transferred from the microcosm bottles in a gas-tight locking syringe to the injector which was held at a temperature of 150°C. Helium was used as the carrier gas at a flow rate of 0.2 mL/min. The oven temperature was held at 45°C for 4 minutes, and then ramped to 60°C at a rate of 10°C /min, ramped to 100°C at a rate of 20°C /min and then held at 100°C for 1 minute, giving a total run time of 8.5 minutes. The detector was held at 240°C where hydrogen, air, and nitrogen (as make up gas) supplied the flame at flow rates of 32, 400, and 30.7 mL/min, respectively.

Hydrogen and oxygen concentrations were quantified using a SRI 8610 B gas chromatograph (GC) equipped with a thermal conductivity detector (TCD) and a Molesieve 5A molecular sieve column (Alltech). Argon was used as the carrier gas at a pressure of 20 psi and the oven was held isothermally at 73°C. Carbon dioxide concentration in headspace of samples was measured using a SRI GC (Model 310) equipped with a TCD and a Porapak Q column. Helium was used as the carrier gas at a pressure of 20 psi and the oven was held isothermally at 83°C.

Perchlorate, chlorate, chlorite, chloride, nitrate, and nitrite were extracted from 5-g soil by vortexing for 1 minute in a 50-mL centrifuge vial containing 20-mL deionized water. A preliminary experiment conducted in triplicate demonstrated that 106.58 \pm 6.1% of perchlorate was recovered from the soil after only 0.5 minutes of vortexing. After vortexing, the extracts were centrifuged at 5000 rpm for 15 minutes and the supernatant filtered through a 0.2- μ m-pore-diameter filter to remove soil particles. The anion concentrations were measured using a DX-500 ion chromatograph (Dionex), equipped with an AS-11 column, and an ED40 Electrochemical Detector. A sodium hydroxide solution eluent with a flow rate of 1 mL/min was used to separate the species over a 30 minute run time. The eluent was composed of 98.7% DI water and 1.3% 200 mM sodium hydroxide at the beginning of each run and held for 10 minutes, then ramped to 96.4% DI water and 3.6% 200 mM sodium hydroxide and held until the time was 17.4 min, ramped to 65.5% DI water and 34.5% 200 mM sodium hydroxide and held from 18.8 min to 23 min, then ramped back to 98.7% DI water and 1.3% 200 mM sodium hydroxide and held until the run ended. The detection limit of nitrate was determined according to the procedure in USEPA Definition and Method for MDL (USEPA, 1986) and was found to be 150 ppm.

Soil moisture content was determined gravimetrically according to D 2216-98 Standard Test Method for Laboratory Determination of Water (Moisture) Content of Soil and Rock by Mass (ASTM, 1999), and the pH of the extracts after centrifuging was measured with a Fisher Accumet AB 15 pH meter equipped with an Orion Thermo Electron combination pH electrode. Total carbon and total nitrogen were determined using a Combustion-Fisons NA 1500 Elemental Analyzer by the Agricultural Analytical Services Laboratory at The Pennsylvania State University.

3.3 Microcosm Test Results

Before the microcosms were initiated, the homogenized soil from the Aerojet site was chemically characterized. The results of the soil characterization are provided in the column marked “original” in Table 3-3. The percentage of total nitrogen of the soil sample was 0.016% ± 0.006% and total carbon was 0.037% ± 0.021% (triplicate averages).

During the microcosm tests, the soil moisture content remained relatively constant in both the low and high soil moisture sets. The soil pH remained near 7. No intermediate perchlorate reduction products (chlorate and chlorite) were detected during the treatment. The nitrate concentration was reduced below the detection limit (150 ppb) at the time zero sampling point in all microcosms at both moisture levels. Nitrite (NO₂⁻), the intermediate product of nitrate reduction, was also below detection (**Appendix A-3**). This high rate of denitrification indicates that anoxic conditions were achieved in the microcosms and that electron donor was available throughout the soil. The average final conditions of all the analytes in the soil after 125-187 days of treatment with the different electron donors under high soil moisture content are summarized in **Table 3-3**. Complete data sets and profiles for each test condition are provided in **Appendix A-3**.

Table 3-3 Original and Final Conditions of the Aerojet Site Soil after 125-187 Days of Treatment Using Different Electron Donors at 16% Soil Moisture. (Table Shows Duplicate Averages Except where Noted.)

		Original	Ethyl Acetate		1-hexene		LPG		Hydrogen	
	mg/kg	-	150	501	80	265	75	250	34	114
Soil moisture	%	8±0.6*	15	15.4	14.72	15.6	12.9	13.85	15.21	15.31
Soil pH	-	6.85±0.3*	6.82	6.58	6.97	6.97	7.84	7.56	7.15	6.38
perchlorate	mg/kg	8.2±1.3*	8.53	9.52	5	1.96	2.71	ND	ND	ND
chloride	mg/kg	-	2.93	3.36	6.21	4.26	6.85	6.03	7.27	8.12
nitrate	mg/kg	2.1±0.3*	ND	ND	ND	ND	ND	ND	ND	ND
electron donor	mg/kg	-	ND	ND	68.07	121	142.5	491.35	56.98	83.33

* = average of soil from 4 buckets after the second time of mixing with two duplicate measurements each.
 ND = non-detect

Perchlorate reduction was not observed in any of the 7% soil moisture sets (**Appendix A-3**), regardless of which electron donor was present. Under high soil moisture (16%), the bioremediation of perchlorate was supported by all the electron donors tested except ethyl acetate (**Figure 3-1**). Complete perchlorate removal was achieved in 35 and 42 days with hydrogen at high and low concentration, respectively. After 184 days of incubation, perchlorate concentration was reduced to less than detectable concentrations in high LPG concentration bottles, but had a residual of 2.71 ppm in low LPG concentration bottles. The concentration of perchlorate was reduced to 1.96 ppm and 5 ppm in high and low 1-hexene concentration bottles, respectively. The 1-hexene bottles were only incubated for 125 days in total due to the higher

frequency of sacrificing at the beginning of the test. Complete perchlorate reduction occurred within 77 days in the positive control and 183 days in the negative control, both of which were only run at 16% soil moisture. The interesting implications of perchlorate reduction in the absence of an external electron donor are explored further in the Discussion section that follows.

Figure 3-1 Perchlorate Degradation in Microcosm Tests with Different Electron Donors at 16% Soil Moisture.

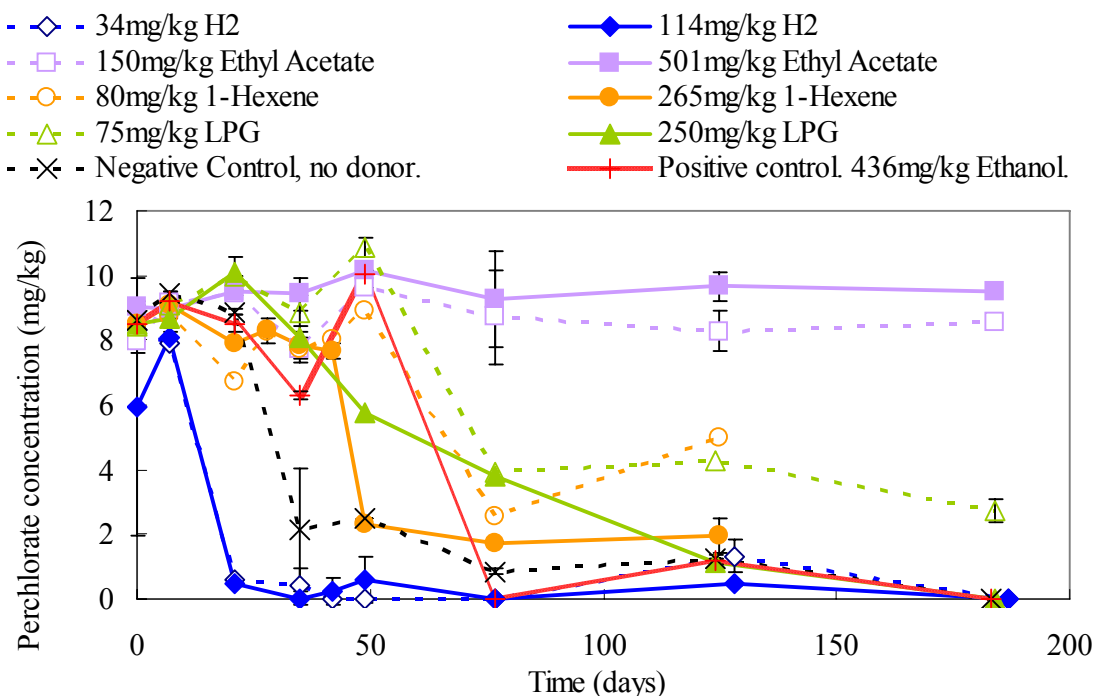

Although the rates of perchlorate degradation are difficult to accurately quantify in this experiment due to the observed shouldering (lag) effect and relatively low sampling frequency, it does appear that perchlorate reduction followed a first order decay (**Figure 3-2**). First order perchlorate reduction has been observed by others (Logan et al., 2001), so this result is not unexpected. Average first order rate constants for perchlorate reduction were estimated for each electron donor based on the slopes of the curves of each profile past the shoulder in **Figure 3-2** (i.e., the slopes of negative $\ln([\text{ClO}_4^-]/[\text{ClO}_4^-]_0)$ vs. time), with the exception of hydrogen and the positive control, which were determined based on the initial straight portion of the curve past the shoulder. Maximum rates of perchlorate degradation were also estimated for each electron donor by choosing the maximum slopes in **Figure 3-2**. The resulting estimated first-order rates of perchlorate degradation, $k_{\text{ClO}_4^-}$ (average) and $k_{\text{ClO}_4^-}$ (maximum), for each electron donor are provided in **Table 3-4**. The highest rates of perchlorate reduction, $k_{\text{ClO}_4^-}$ (maximum), were found for ethanol and hydrogen (high concentration), followed by hydrogen (low concentration); 1-hexene (high

concentration), negative control, LPG (high concentration), 1-hexene (low concentration), LPG (low concentration), and finally ethyl acetate.

Figure 3-2 Relative Change in Perchlorate Concentration Over Time Used to Estimate First Order Rate Constants.

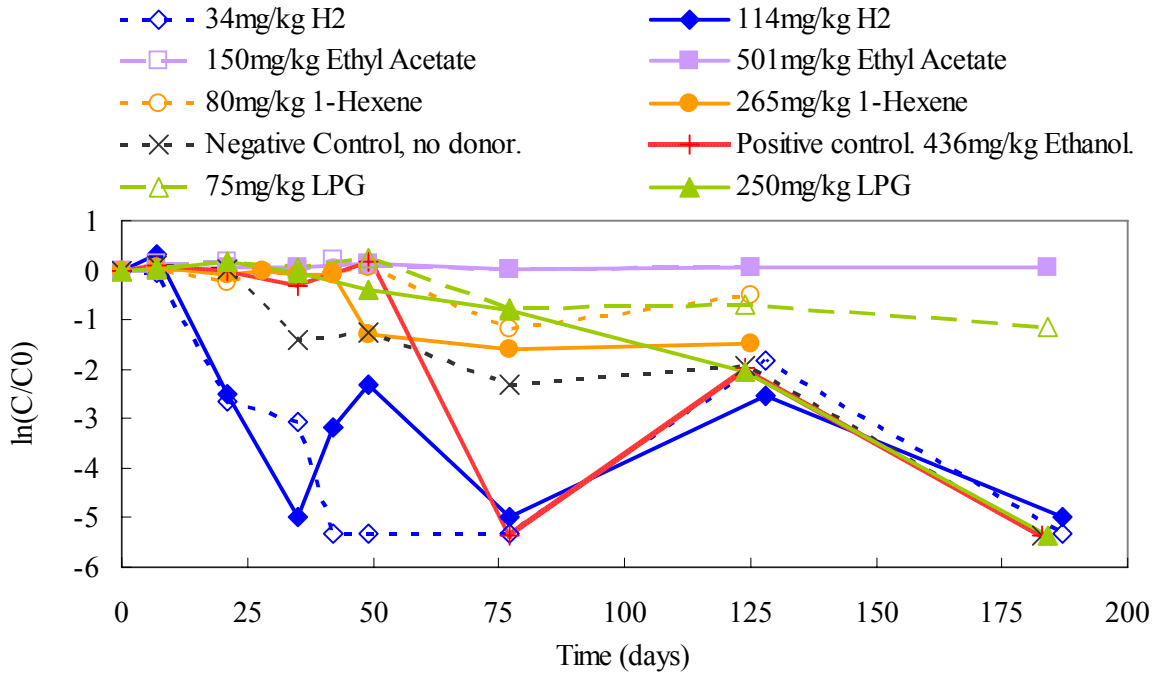

Table 3-4 First Order Perchlorate Degradation Rate Constants, Lag Periods, and Final Perchlorate Concentrations for the Electron Donors Tested in the Microcosm Tests at 16% Soil Moisture.

		$k_{\text{ClO}_4^-}$ (average) [#] (day ⁻¹)	$k_{\text{ClO}_4^-}$ (maximum) [*] (day ⁻¹)	Lag period (days)	$C_{\text{ClO}_4^-}$ final (mg/kg)
H₂	Low	0.13	0.19	7	0.04 [*]
	High	0.19	0.20	7	0.04 [*]
LPG	Low	0.0083	0.037	49	2.71
	High	0.033	0.055	21	0.04 [*]
1-hexene	Low	0.0079	0.045	28	2.54
	High	0.016	0.17	28	1.96
Ethyl acetate	Low	0	0	>125	8.53
	High	0	0	>184	9.52
Negative Control		0.0027	0.10	21	2.12
Positive Control		0.20	0.20	49	0.04 [*]

Rates were estimated based on the slopes of the whole curves past lag periods except for H₂ and Positive control. The rates of H₂ were determined from the data of 7-42 days for low concentration and 7-35 days for high concentration. The rate for the positive control was determined by the data of 49-77 days.

* The maximum perchlorate reduction rate observed for each donor during incubation.

The calculation was based on the data from:

H₂ (low): 7-21 days; H₂ (high): 7-21 days;
 LPG (low): 49-77 days; LPG (high): 124-184 days;
 1-hexene (low): 49-77 days; 1-hexene (high): 42-49 days;
 Negative control: 21-35 days; Positive Control: 49-77 days.

* Perchlorate was non-detectable. The number 0.04 is ten times the method detection limit.

3.4 Discussion

From the results of the microcosm test, it is obvious that high soil moisture is critical to perchlorate bioremediation. Another study which tested the GEDIT technology also concluded that soil moisture is the key factor (Evans and Trute, 2006). A similar conclusion was obtained in a pilot study of *in situ* perchlorate bioremediation at The Longhorn Army Ammunition Plant (LAAP) (Nzengung et al., 2003), which found that the best treatment results were achieved in the wettest (saturated) soils. For GEDIT, however, it may be impractical to increase *in situ* soil moisture. In this microcosm test, 7% was too low to support perchlorate bioremediation and 16% was successful at reducing perchlorate in most bottles, but 16% may not be the minimum required moisture. The purpose of this study was to determine the potential for perchlorate biodegradation at the observed limits of ambient soil moisture. This study clearly demonstrated

that perchlorate biodegradation may be limited in soil containing 7% moisture. In the field demonstration, it will be important to assess further the relationship between soil moisture content and perchlorate reduction and also to determine the optimum moisture for both perchlorate bioremediation and electron donor transport.

Of the electron donors tested, hydrogen appears to be the most promising for several reasons. The high Henry's constant of hydrogen gives it excellent mobility in the gaseous phase (**Table 3-2**), and its small molecular size enables it to easily diffuse into zones of low permeability. In addition, the simple hydrogen molecule is readily utilized by microorganisms. Hydrogen has been widely used as an electron donor for isolating perchlorate-reducing bacteria and has also been used in the treatment of (per)chlorate contaminated water (Miller & Logan, 2000; Nerenberg et al., 2002; Kroon & van Ginkel, 2004).

In this experiment there was a 7 day lag period in both high and low hydrogen bottles before perchlorate degradation began. This lag period is similar to the 14 day lag period observed in another study of perchlorate bioremediation in vadose zone soil with hydrogen as the electron donor (Nozawa-Inoue et al., 2005). Shorter lag periods for perchlorate degradation with hydrogen/carbon dioxide than other electron donors may also imply that there are more autotrophic than heterotrophic perchlorate-reducing microbial populations in the soil. The observed perchlorate reduction rate $k_{\text{ClO}_4^-}$ was almost the same in the low and high hydrogen concentration bottles. There is not sufficient data, however, to imply a relationship between hydrogen concentration and perchlorate reduction rate due to lack of sampling points between day 7 and day 21. To examine how higher hydrogen concentrations affect perchlorate reduction rate, a higher sacrificing frequency between 7 and 21 days of incubation is needed. Assuming a first order reaction (Logan et al., 2001), the maximum observed perchlorate reduction rate, $k_{\text{ClO}_4^-}$ (maximum), obtained from this research is on the same order of magnitude as those obtained by others with slurry sediments/soils (**Table 3-5**). This indicates that saturated soil conditions are not necessary to produce high perchlorate reduction rates.

Table 3-5 First Order Perchlorate Reduction Rates Observed in the Literature and Their Experimental Conditions.

Soil	Electron Donor (mg/kg)	Soil moisture	Rate $k_{ClO_4^-}$ (d ⁻¹)	Source
HW84 Sidestream	TVS (115.9)	Slurry	0.37±0.07	Tan, 2003
HW84 Mainstream	TVS (84.5)	Slurry	0.14±0.02	
Longhorn	TVS (43.3)	Slurry	0.16±0.08	
HW317	TVS (160.5)	Slurry	1.42±0.67	
HW317/MN	TVS (70.6)	Slurry	0.11±0.03	
Aerojet	H ₂ (34 -114)	16%	0.19-0.20	This research
	LPG (75 – 250)	16%	0.037-0.056	
	1-hexene (80-165)	16%	0.045-0.17	
	None (H ₂ ?)	16%	0.10	
	Ethanol	16%	0.20	

TVS = Total volatile solids in the sediments/soils (a rough approximation of the amount of organic matter content in the sediments. Tested with the standard method (APHA et al., 1998)).

The overall observed favorability of electron donors in this experiment, taking into account both the rates and extent of perchlorate reduction, was ethanol > H₂ > LPG > 1-hexene > ethyl acetate. The reason why ethyl acetate failed to serve as electron donor for perchlorate remediation in this microcosm test is not clear. Ethyl acetate was tested in another study of GEDIT (Evans and Trute, 2006), in which approximately 10% perchlorate removal was observed in the middle and end of a column containing 10% soil moisture while no perchlorate reduction occurred at the first 1/3 of column after 34 days of incubation. Ethanol was also tested in that research and showed promising perchlorate reduction but poor transport in column tests. Propane has been tested to a limited extent; however, it was shown to support perchlorate reduction only in one case. (Envirogen, 2002; Hoponick, 2006). To the best of our knowledge this is the first research reporting the use 1-hexene as an electron donor for perchlorate bioremediation.

Nitrate was not detected after the t = 0 sampling point, and nitrite was below detection throughout the experiment. The ability of gaseous electron donors to support denitrification has significant implications for the potential remediation of this common subsurface contaminant. The National Water Quality Assessment (NAWQA), a program of the US Geological Survey, has documented that nitrate is the pollutant that most frequently exceeds its standard limits (Squillace et al., 2002). According to the EPA, more than 59 millions pounds of nitrite/nitrate were released to water, and more than 53 millions of pounds to land, between 1991 and 1993. High nitrate levels are usually found in shallow aquifers underneath agricultural areas with well drained soils and permeable vadose zones (Spalding and Exner, 1993; Squillace et al., 2002). This research indicates that GEDIT could be used to treat nitrate in these high-risk, permeable vadose zones, thereby reducing potential nitrate contamination of groundwater supplies.

The intermediate products of perchlorate reduction (chlorate and chlorite) were not detected during these microcosm tests, similar to the results of other research which documented that perchlorate reduction to chlorate is the rate limiting step. Chlorate accumulation has been reported, however, in both mixed and pure cultures of hydrogen-oxidizing, perchlorate-reducing bacteria (Nerenberg et al., 2002, Nerenberg et al., 2006).

Complete perchlorate reduction occurred in the negative control which contained no external electron donor, and the degradation rate was higher than that observed for 1-hexene (low concentration), LPG, and ethyl acetate. Although there was sufficient carbon in the soil (total C = 0.037% = 308 μmol in 10 g soil) to theoretically account for this perchlorate degradation (10 mg/kg = 1 μmol in 10 g soil) if it was bioavailable, all treatments would have had similar benefit. The only other explanation for why the negative control exhibited such a high rate of perchlorate reduction is that another electron donor was generated and subsequently utilized in the negative control bottles. During the experimental setup, the bottles were filled with soil, purged with nitrogen, and allowed to sit on the open lab bench for at least one day. Immediately after flushing with nitrogen, no hydrogen was detected in the headspace, but after sitting in the light of the laboratory, a small amount of hydrogen was detected in all of the bottles, before any electron donor was injected. This hydrogen peak remained in all of the bottles throughout the entire incubation, except for the negative control. In the negative control bottles, the change of perchlorate concentration and hydrogen concentration seems related (**Figure 3-3**). During the first 14 days, hydrogen was accumulating during the lag period prior to perchlorate biodegradation. Then, perchlorate and hydrogen concentration dropped simultaneously. The measured hydrogen concentration change (1.4 mg/kg) from day 14 to day 49 is approximately twice the stoichiometric electron donor requirement for perchlorate reduction (with a 6.4 ppm perchlorate concentration change). The $k_{\text{ClO}_4^-}$ in the negative control, however, was only 1/5 of that for the low concentration hydrogen bottles (**Table 3-4**). There was also a longer lag period. This may indicate the perchlorate degradation in the negative control was limited by the concentration of hydrogen.

Figure 3-3 Perchlorate and hydrogen concentration changes over time in negative control microcosms containing no external electron donor at 16% soil moisture.

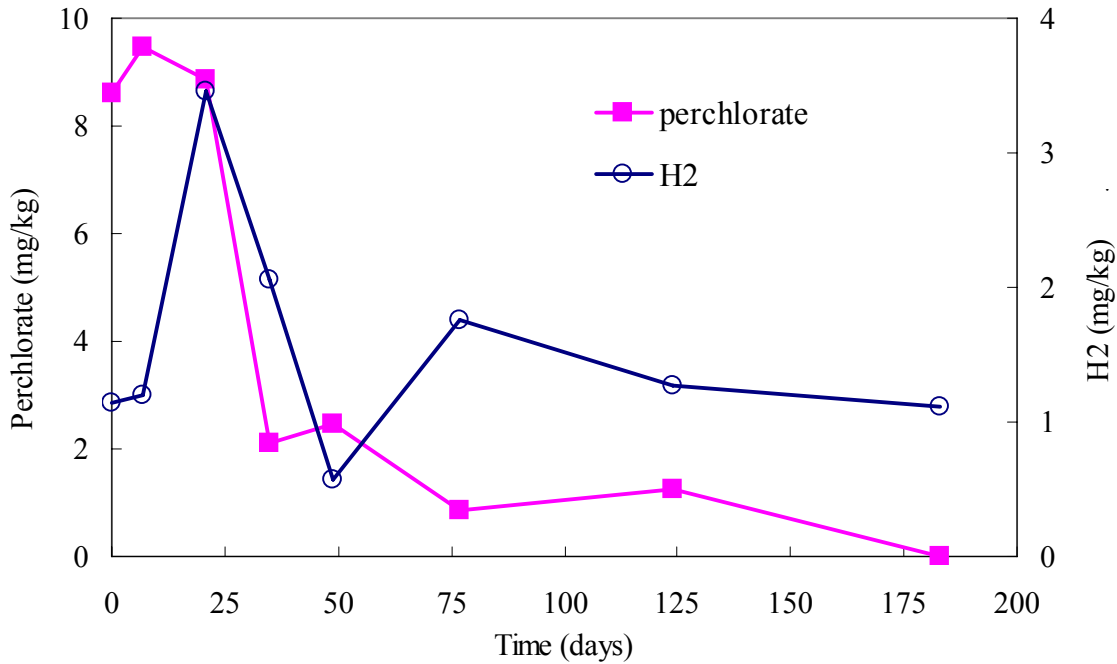

To prove that the hydrogen detected in non-hydrogen-injected bottles was produced biologically, a small experiment was performed. For this experiment, microcosm bottles were set up in duplicate in the same way as described in the Materials and Methods section with a nitrogen gas (N_2) headspace and Aerojet soil at 16% moisture. The following four conditions were tested: 1) Empty Controls containing only N_2 ; 2) Autoclaved Controls containing autoclaved soil; 3) Active-Light containing soil incubated in the light on the bench; and 4) Active-Dark containing soil incubated in dark (**Table 3-6**). All bottles were incubated on the bench for one day except the Active-Dark which were incubated in a dark drawer. No hydrogen accumulation was detected in either the empty or autoclaved controls (kept on the open bench), which eliminated the possibility that the hydrogen was introduced with the nitrogen gas or was the result of an abiotic reaction in the soil. For the Active ones, the two bottles left in the light on the open lab bench (as what happened in the microcosm test) generated hydrogen which was detected the next day, whereas the two bottles incubated in the dark immediately after setup showed no hydrogen production (**Table 3-6**.)

Table 3-6 Setup and Results of the 1-day Hydrogen Production Test with the Aerojet Soil at 16% Soil Moisture.

	Soil	Purged w/ N ₂	Autoclaved	Incubate	Initial H ₂ (uM)	Final H ₂ (uM)	Hydrogen Produced
Empty Control	No	Yes	No	Light	0	0	No
Autoclaved Control	Yes	Yes	Yes	Light	0	0	No
Active-Light	Yes	Yes	No	Light	0	3.06±0.34	Yes
Active-Dark	Yes	Yes	No	Dark	0	0	No

Based on the results of this experiment, it seems that hydrogen producing microorganisms are present in the Aerojet site soil and that they are photoautotrophic. These ubiquitous, spore-forming organisms (Cheong and Hansen, 2006) were likely washed down into the subsurface soil in spore-form during rainfall events and after the soil moisture was adjusted, anoxic conditions achieved, and light applied in the laboratory, they germinated because the conditions in microcosm bottles were favorable. H₂-photoproducing microorganisms, such as purple bacteria (BioCycle, 2004), can convert organic residuals in the soil to hydrogen and carbon dioxide in the presence of light as shown in the equation below (this equation is written for the simplest carbon source, carbon monoxide, but it can similarly be balanced for other organic compounds):

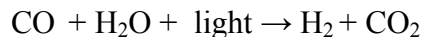

Even though hydrogen production should be accompanied by carbon dioxide production as shown in the equation above, no carbon dioxide was detected in the negative control bottles. It is possible that the concentration of carbon dioxide was too low to be detected by the GC, and it is also possible that part of the carbon dioxide produced was used as a carbon source for perchlorate biodegradation, or remained dissolved as bicarbonate. In those bottles with external electron donors of ethyl acetate, 1-hexene (low concentration), and LPG, even though small amount of hydrogen was also detected, the perchlorate degradation rate was lower than that in the negative control. This may indicate that these chemicals are toxic to hydrogenogens and/or perchlorate reducing microorganisms and inhibited their activity, but no evidence has been found in the literature to support this conjecture. To better explain the results, a study of the microbial community in the Aerojet soil using molecular microbial ecology techniques, and a study of the possible toxicity of the tested electron donors to these bacteria, may be needed. However, since photoautotrophic hydrogenogens require light to produce hydrogen, it is unlikely that they would provide any benefit to the *in situ* remediation being proposed, regardless of which external electron donor is applied.

4.0 Column Test Results

4.1 Abstract

A series of column studies were conducted to quantify the transport rate of the best performing electron donor from the microcosm study through vadose zone soil from the site containing 10% soil moisture. After quantifying the transport rate, the columns were incubated for one to two months to evaluate the resulting extent of perchlorate degradation. In the first column study, 20% hydrogen (H₂) (balance nitrogen, N₂) was tested as the sole electron donor, without any added carbon source. Hydrogen breakthrough times were 3.4 and 5.6 hours. Complete nitrate reduction was achieved in both columns but no perchlorate degradation was detected in column #1 after 4 weeks of incubation or in column #2 after 10 weeks of incubation. To eliminate the possibility of carbon limited perchlorate reduction and to leverage the positive microcosm results with propane, a mixture of 2% propane, 10% CO₂, 20% H₂, and 68% N₂ was tested in the second column study. The breakthrough times of hydrogen were 7.2 hours and 8.0 hours. Complete nitrate reduction was achieved in both columns #3 and 4 but no perchlorate degradation was detected in column #3 after 4 weeks of incubation or in column #4 after 8 weeks of incubation. A small batch test conducted after the column experiment indicated that that storage of the soil prior to conducting the column study and low soil moisture content both resulted in the lack of perchlorate degradation.

4.2 Materials and Methods

4.2.1 Experimental Design and Setup

The column studies were conducted in columns made of clear polyvinylchloride (PVC) pipes measuring 2 inches in diameter and 5 feet in length. The ends were capped with 2-inch-diameter PVC caps and stainless steel Swagelok fittings. Sampling ports consisting of drilled holes plugged with thick butyl rubber stoppers were placed every 2 inches along the length of the columns (29 in total) to enable the discrete measurement of gaseous electron donor transport (Figure 4-1).

Figure 4-1 Schematic and Photograph of the GEDIT Column System in the Laboratory.

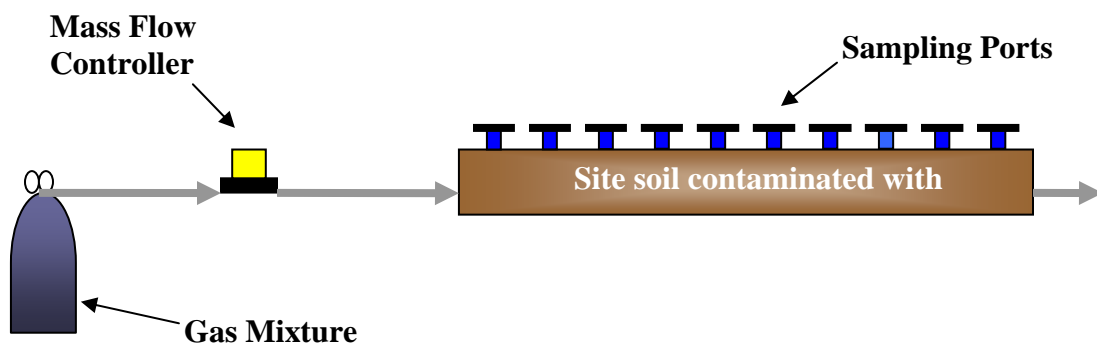

Prior to packing the columns, the soil moisture was adjusted to 10% by adding distilled water and mixing well. An attempt was made to run the columns at the average soil moisture of the microcosm tests (12%), but at this level the monitoring of electron donor concentrations along the column length was impeded due to the high-moisture soil clogging the gas-tight syringe needle as soon as it was inserted into the column. Therefore, 10% soil moisture content was chosen as a compromise that enabled easier monitoring of soil gas in the columns. The columns were packed by adding 1-2" lifts of soil and tapping the sides of the column between lifts to promote even soil distribution. Each column was packed with a total of 4.94 kg soil to achieve a soil density of 1.6 g/ml. After packing, the column caps and the stoppers placed in the sampling ports were sealed with Epoxy glue. Duplicate columns were made for each test. Prior to injecting the electron donor, the tubing connections and column sampling ports were leak-tested while the column was being purged with nitrogen gas at a flow rate of 4.9 ml/min.

4.2.1.1 Hydrogen Column Setup

Two duplicate columns (Column #1 and #2) were set up on January 21 and 22, 2007, to test hydrogen as the sole external electron donor. Before introducing hydrogen to each column, the columns were purged with nitrogen gas at a flow rate of 4.9 ml/min (0.01 cm/s average linear velocity) for approximately 10 hours (2.4 pore volumes) until less than 1% oxygen was detectable in the column effluent to ensure anoxic conditions. A gas mixture consisting of 20% hydrogen and 80% nitrogen was then purged through the columns at a flow rate of 4.9 ml/min via mass flow rate controllers (AALBORG, Model# GFC17). The effluents of the columns were tested for hydrogen concentration every half hour to capture breakthrough curves. After hydrogen was observed to travel from the beginning to the end of the columns and reached the same hydrogen concentration throughout, the gas injection was stopped and the column ends capped. Headspace samples were taken with a 250- μ L gas-tight locking syringe (Hamilton) from seven ports spaced evenly along the column length to construct a hydrogen profile. The columns were then incubated in dark at room temperature for 4-10 weeks. During incubation, headspace samples were taken along the column length to check hydrogen and oxygen concentration every 1-2 weeks. Columns were repurged with the 20% hydrogen / 80% nitrogen gas mixture every 2-3 weeks when >1% oxygen concentration was detected in the column, or when the hydrogen concentration was observed to significantly decrease.

After 4 weeks of incubation, Column #1 was sacrificed and the soil samples behind every other sampling port analyzed for perchlorate, chlorate, chlorite, chloride, nitrate, nitrite, pH and soil moisture. The other duplicate column (Column #2) was sacrificed after 10 weeks of incubation and the soil similarly analyzed.

4.2.1.2 Four-Gas Mixture Column Setup

Another column study was similarly performed in which 10% carbon dioxide (CO₂) was added as a carbon source, 20% hydrogen and 2% propane (the main component of LPG) were added as electron donors, and the balance was nitrogen. The resulting four-gas-mixture, consisting of 2% propane, 10% carbon dioxide, 20% hydrogen, and 68% nitrogen was added into columns #3 and #4 on March 28 and 30, 2007. Columns #3 and #4 were monitored, sacrificed, and analyzed as described above after 4 and 8 weeks of incubation, respectively.

4.3 Results

4.3.1 Hydrogen Column

In Column #1, hydrogen breakthrough time was calculated as 3.4 hours (0.81 pore volumes) (Shackelford, 1994), while it took approximately 5.58 hours (1.32 pore volumes) for hydrogen to breakthrough in Column #2 (**Figure 4-2**, see **Appendix A-4** for breakthrough time calculations). After 21 days of incubation, the hydrogen concentration in both Columns #1 and #2 were found to have decreased to 1% of the incubated concentration, and oxygen was detected in Column #2. A leak at the column outlet cap was detected in Column #2 and repaired. Both columns were re-purged with 20% hydrogen / 80% nitrogen gas mixture and then incubated. Before sacrificing, Column #2 was re-purged for two more times at 42-days and 63-days of incubation to replenish the hydrogen concentration (no oxygen was detected in column #2 during this period).

Figure 4-2 Hydrogen Breakthrough Curves for Column #1 and #2 with 10% Soil Moisture.

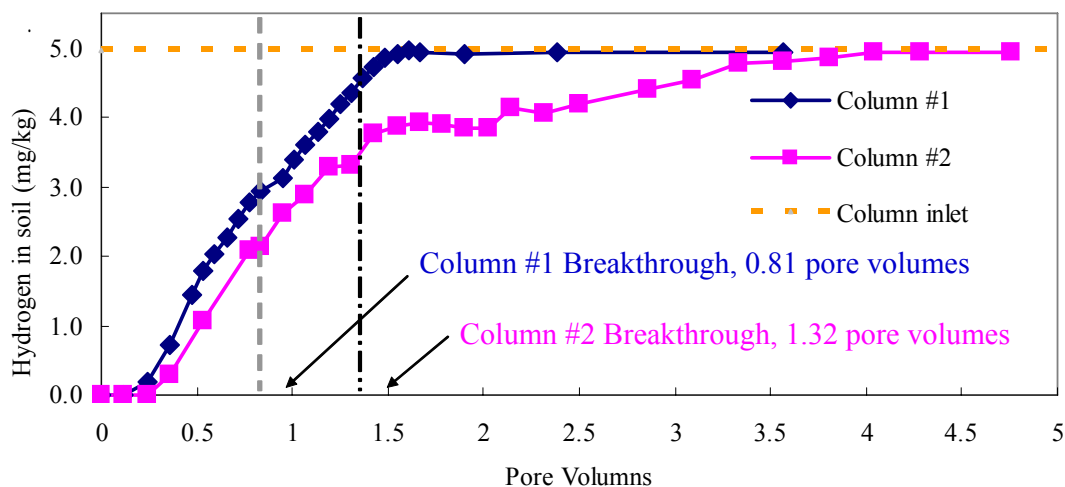

After 4 weeks of incubation, no appreciable perchlorate degradation was detected in Column #1 (**Figure 4-3**), and no chlorate or chlorite were observed. The concentration of hydrogen was decreased from the initial conditions, but approximately uniform with length at 3 mg/kg, indicating that no hydrogen “floating” occurred. Soil moisture was retained its original value at approximately 10% along the column length, and pH was approximately 6.5. No nitrate (NO_3^-) or nitrite was detected in any of the soil samples from Column #1, compared to the original background concentration in the soil of $2.1 \pm 0.3 \text{ ppm NO}_3^-$.

Figure 4-3 Perchlorate, Chloride, Hydrogen, Nitrate, and Soil Moisture Along Column Length in Column #1 after 4 Weeks of Incubation. Intermediate degradation products (chlorate, chlorite, and nitrite) were not detected.

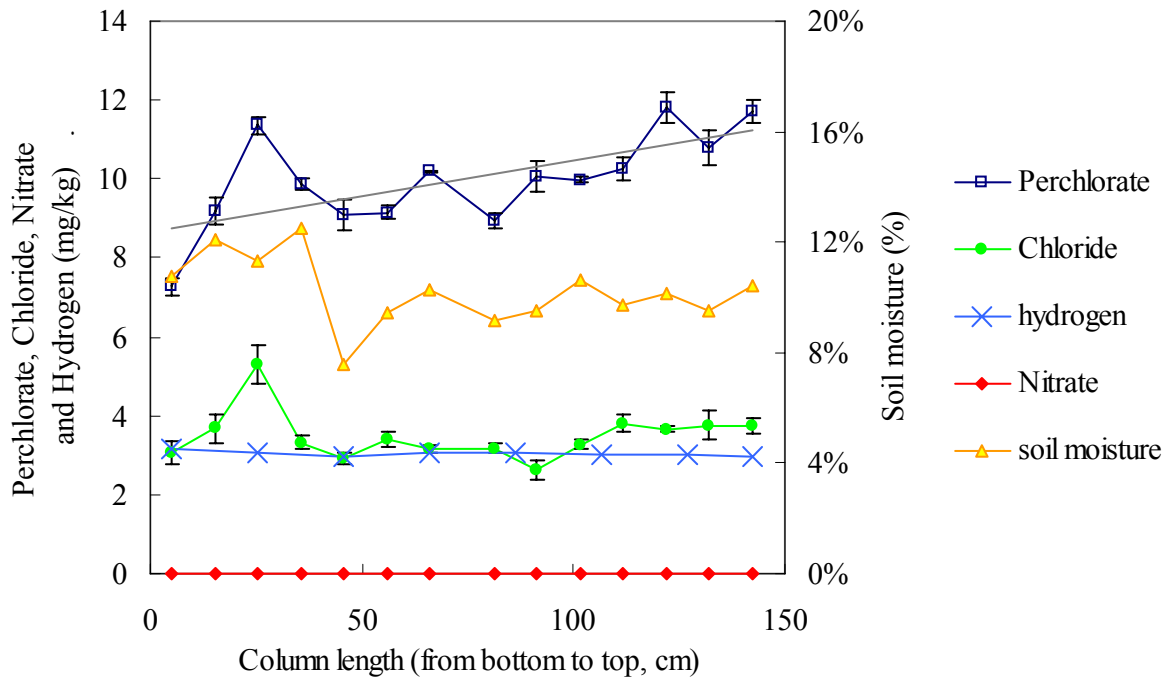

After another 6 weeks, Column #2 was sacrificed after being purged two more times with the 20% H₂ / 80% N₂ gas mix, but still no perchlorate reduction or perchlorate intermediates were observed (**Figure 4-4**). Along column length, hydrogen concentrations were fairly uniform, at 2.5 mg/kg. Soil moisture was approximately 10% along the column length and pH was approximately 6.6. Nitrate and nitrite were not detected in any soil samples from Column #2.

Figure 4-4 Perchlorate, Chloride, Hydrogen, Nitrate, and Soil Moisture Along Column Length in Column #2 after 10 Weeks of Incubation. Intermediate Degradation Products (Chlorate, Chlorite, and Nitrite) Were Not Detected.

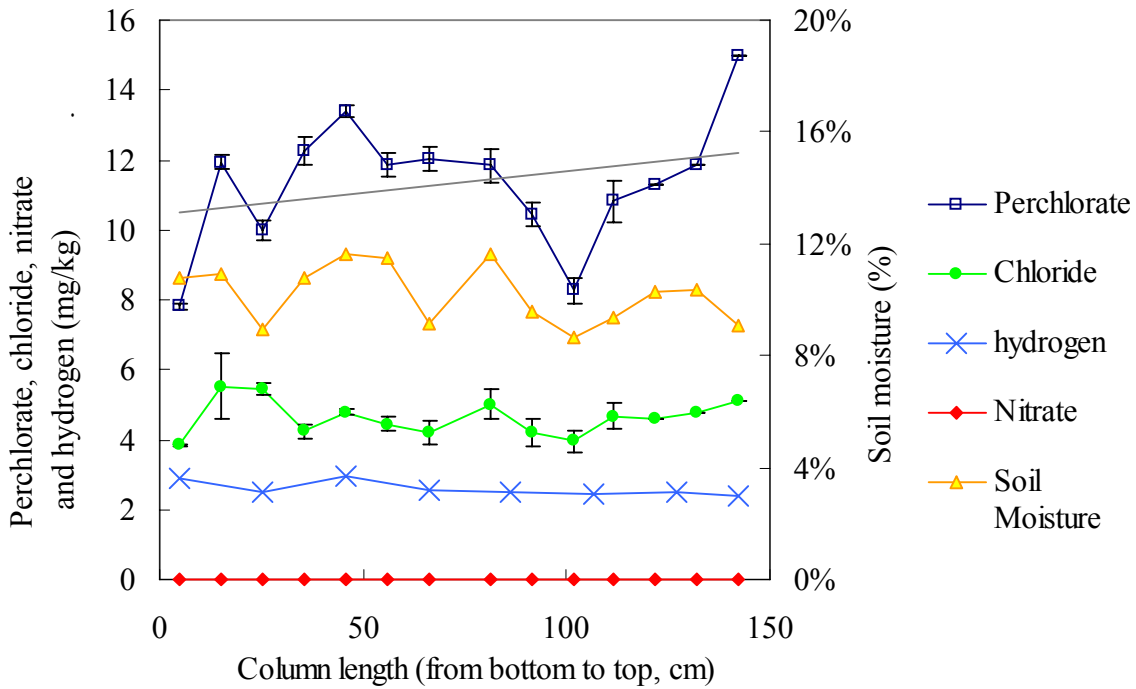

4.3.2 Four-Gas-Mixture Column

The hydrogen breakthrough occurred at almost the same time (7.2 hours (1.7 pore volumes) and 8.04 hours (1.9 pore volumes)) in columns #3 and #4, respectively, even though there was a longer lag period in column #4 (**Figure 4-5**).

Figure 4-5 Hydrogen Breakthrough Curves for Column #3 and #4 with 10% Soil Moisture.

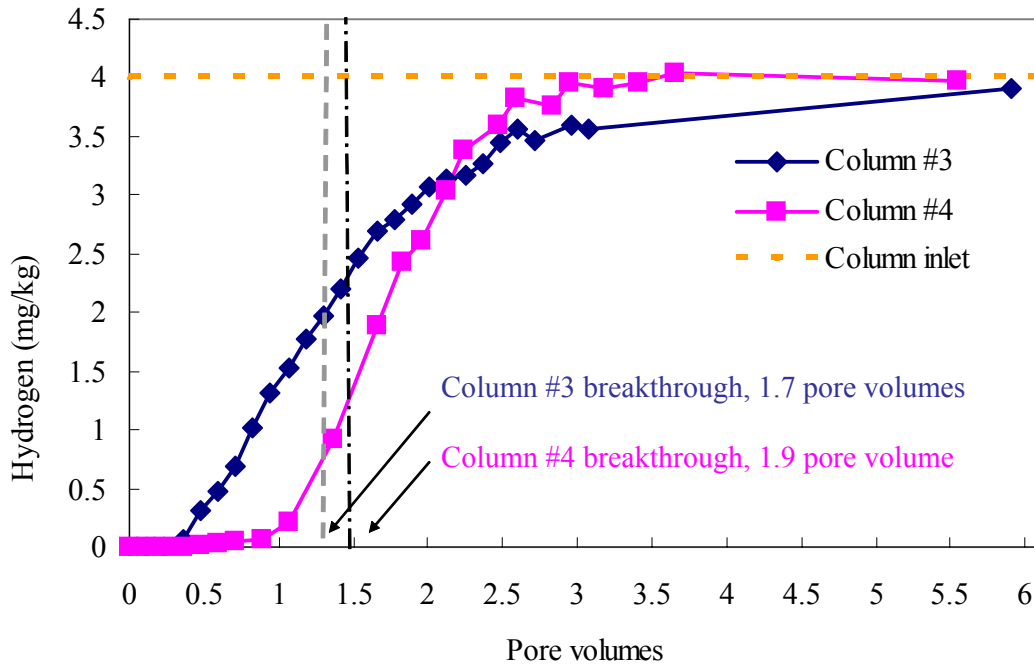

The component gas concentrations were also monitored along the column length. Immediately after the columns were capped, the percentage of propane, carbon dioxide and hydrogen in the column was approximately the same as designed: 2% propane, 10% carbon dioxide, and 20% hydrogen (**Figure 4-6** and **Figure 4-7**).

Figure 4-6 LPG, H₂, and CO₂ Profiles Along the Length of Column #3 at the Start of Incubation.

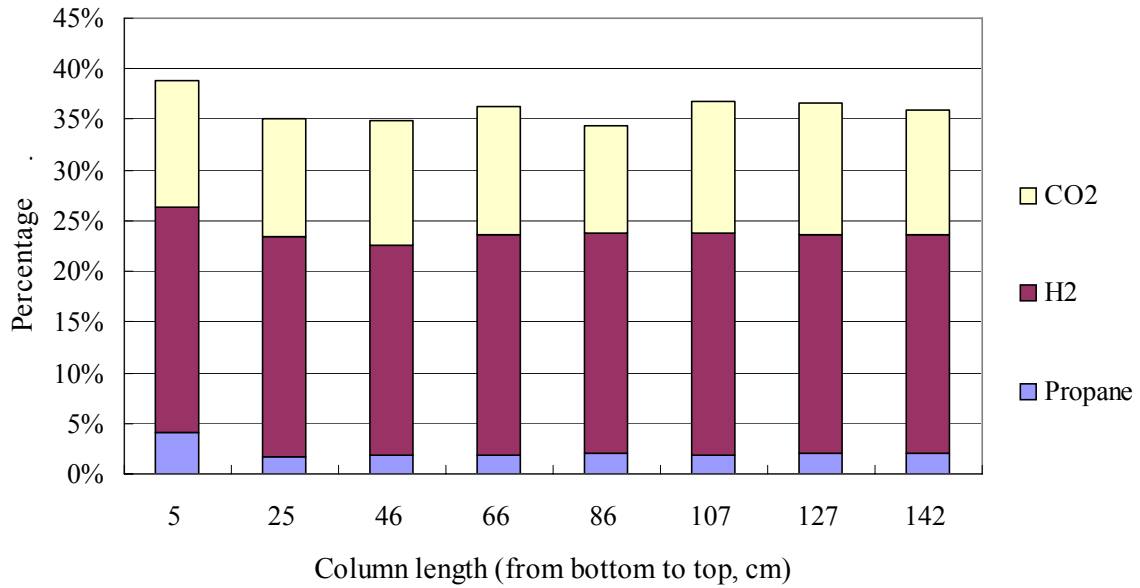
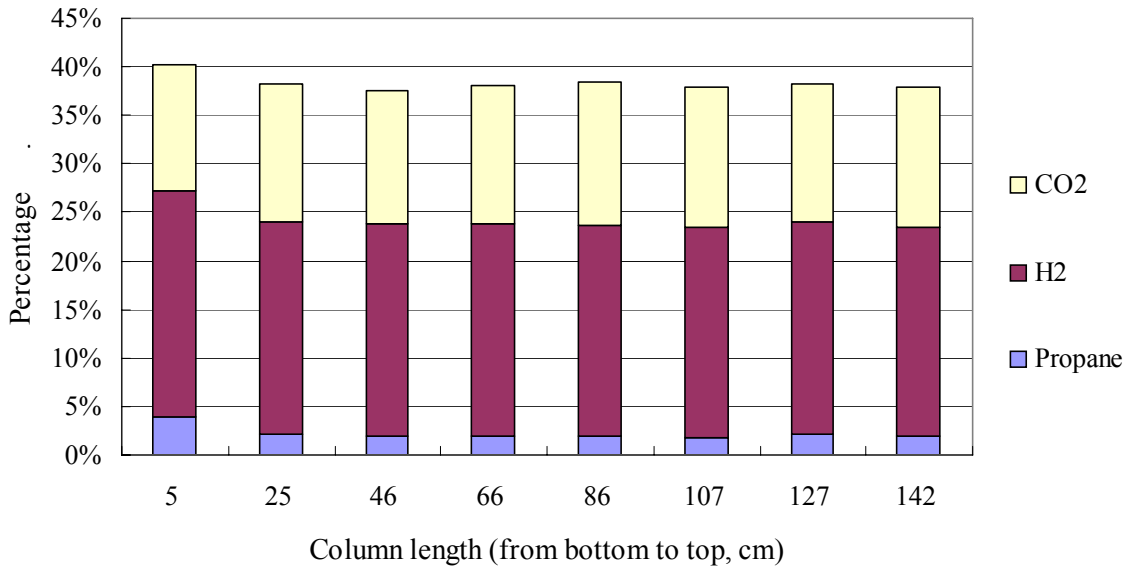
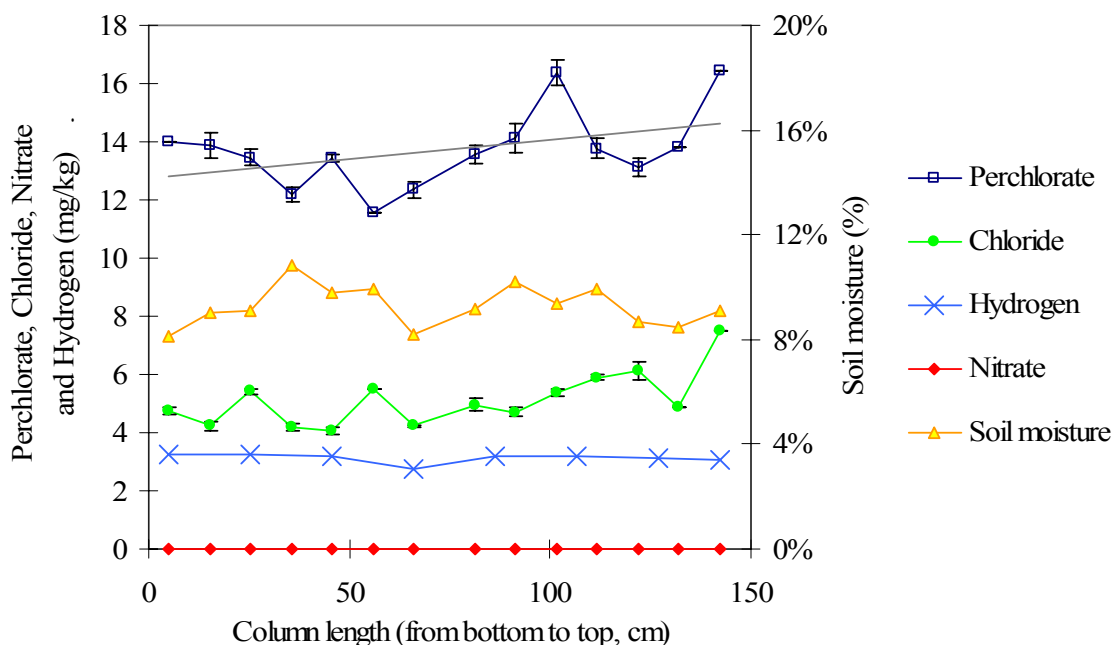

Figure 4-7 LPG, H₂, and CO₂ Profile Along the Length of Column #4 at the Start of Incubation.



Column #3 was purged with the 4 gas mixture (2% propane / 10% CO₂ / 20% H₂ / 68% N₂) once at 23 days of incubation to replenish diminishing hydrogen levels. After 4 weeks of incubation, no appreciable perchlorate degradation was detected in Column #3 (**Figure 4-8**), and no chlorate or chlorite were observed. The concentration of hydrogen was decreased from the initial conditions, but approximately uniform with length at 3.1 mg/kg. Soil moisture was maintained near its original value at an average 9.3% along the column length, and pH was approximately 7.0. No nitrate (NO₃⁻) or nitrite was detected in any of the soil samples from Column #3.

Figure 4-8 Perchlorate, Chloride, Hydrogen, Nitrate, and Soil Moisture along Column Length in Column #3 after 4 Weeks of Incubation. Intermediate Degradation Products (Chlorate, Chlorite, and Nitrite) Were Not Detected.



Column #4 was purged twice with the four gas mixture (2% propane / 10% CO₂ / 20% H₂ / 68% N₂) at 22 and 47 days of incubation, but no perchlorate reduction or perchlorate intermediates were observed after 8 weeks of incubation (**Figure 4-9**). Along column length, hydrogen concentrations were fairly uniform, at an average of 2.8 mg/kg. Soil moisture was an average of 9.8% along the column length and the pH was approximately 7.6. Nitrate and nitrite were not detected in any soil samples from Column #4. To check for the possibility of biofouling, a traceable manometer pressure vacuum gauge (Fisher Scientific) was used to monitor the pressure change across the length of Column #4. A change of only 0.008 psi was observed from the top to the bottom of the column, indicating that biofouling was likely not occurring in this column.

Figure 4-9 Perchlorate, Hydrogen, Nitrate, and Soil Moisture along the Column Length in Column #4 after 8 Weeks of Incubation. Intermediate Degradation Products (Chlorate, Chlorite, and Nitrite) Were Not Detected.

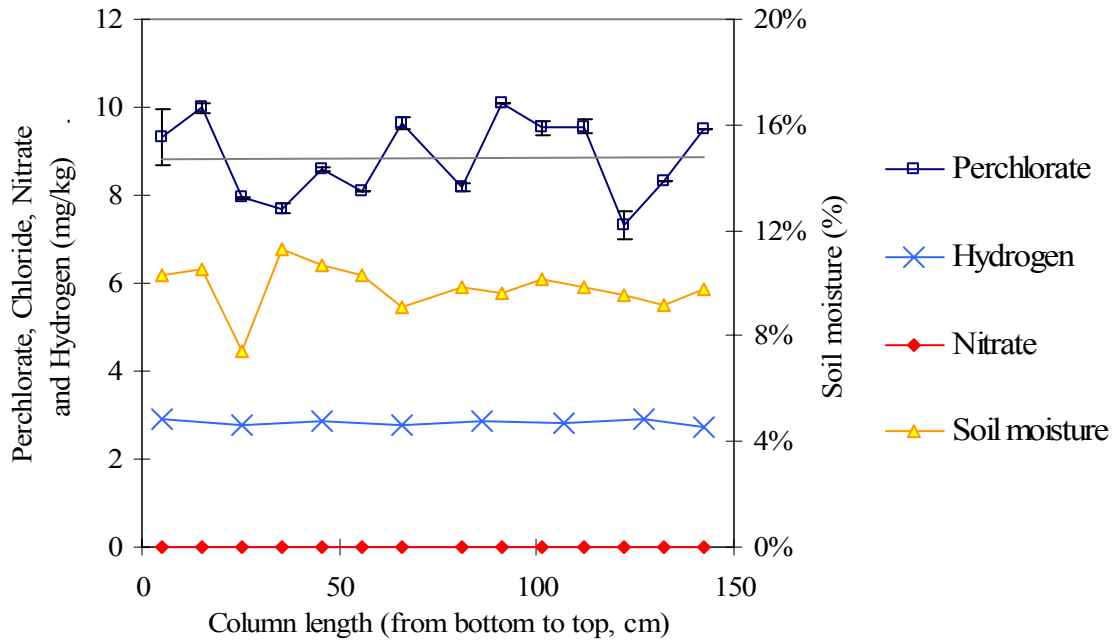

4.4 Discussion

Even though the columns were packed in the same way and had the same density as the site soil, the H₂ breakthrough curves were variable between columns. This variability may have been caused by different soil particle sizes and relative locations in each column causing preferential pathways and therefore different retention times. Longer sitting (i.e., settling) time may have changed the micro-distribution of soil in the columns as well. Columns that were packed and then immediately purged (Columns #2 and #4), seemed to have longer retention times than those that were allowed to settle before being purged (Columns #1 and #3). Compared with the theoretical breakthrough time calculated as 4.23 hours (**Appendix A-4**), all columns took a longer time to breakthrough except Column #1. This may be because Column #1 was the “oldest” column had been packed the earliest and purged with gas several times before conducting the column test. Column #2 was later found to have a leak, so this could be the reason for delayed breakthrough in this column. The columns with the 4-gas-mixture propane/CO₂/H₂/N₂ (columns #3 and #4) had significantly longer H₂ breakthrough times than the columns containing the 2-gas-mixture, H₂/N₂. It seems that the components of the gas mixture altered transport through the column. Propane is a significantly larger molecule than hydrogen with a greater affinity for soil sorption, so it is possible that hydrogen molecules became entrapped in soil micropores that were blocked by propane molecules at the pore throats. The phenomenon of size exclusion and pore blockage has been documented in the literature for other

compounds (Poulsen et al., 2006; Kwon and Pignatello, 2005), however, we were unable to find documentation of this occurrence for propane and hydrogen.

Complete denitrification was achieved in all columns, but no perchlorate reduction was observed. Even though many researchers have reported preferential nitrate reduction prior to the onset of perchlorate degradation (Nozawa-Inoue et al., 2005), there was no change in perchlorate concentration between columns #1 and #2 even after incubating for more than 10 weeks (**Figure 4-10**). There are several reasons which may be responsible for the lack of perchlorate degradation in the columns including oxygen infiltration, low soil moisture, lack of carbon source, insufficient electron donor, and/or extended soil storage time. The column was made with clear PVC, which is a slightly oxygen permeable material (Doyon et al., 2006). Therefore, it is possible that the electron donor concentration was decreasing because it was being consumed by oxygen infiltrating into the column, and perchlorate degradation was inhibited by the presence of oxygen. Lack of moisture may have also impeded perchlorate reduction in the columns. Microcosm test results showed that 7% moisture content is too low to support perchlorate biodegradation. Ten percent in this column test is higher than 7%, but it is not clear that if it is high enough to support perchlorate reduction. In future tests, a method for sampling the soil gas in the columns even in the presence of high soil moisture should be developed. Lack of available carbon could also have impeded perchlorate degradation in Column tests #1 and #2 since no carbon dioxide was injected with the hydrogen gas. The natural organic carbon in the soil (0.037% = 150 mmol total carbon) was theoretically enough to support complete degradation of perchlorate in the columns (10 mg/kg perchlorate = 0.5 mmol perchlorate requiring 1.0 mmol carbon if H₂ is the electron donor source, based on stoichiometry); however, at least 0.7% of the natural carbon in the soil must be bioavailable and present as organic carbon for this to occur. The amount of electron donor that could be added to the column at a given time was less than that used for the microcosm studies (i.e., mg electron donor per kilogram soil). While additional electron donor was added to the columns as it was consumed or otherwise lost, the total concentration of electron donor added to soil in the column studies was less than that in the microcosm studies. This may have also affected the results. Another reason for lack of perchlorate reduction could be the extended storage time of the soil before the column experiments were performed. The soil was collected in August 2006, and was sitting in the lab for over 5 months before the column study was initiated, which may have compromised the bacterial community and may have resulted in the lack of perchlorate reduction observed.

Figure 4-10 Perchlorate, Chlorate, and Nitrate Concentrations in Hydrogen Columns with 10% Soil Moisture after 4 and 10 Weeks of Incubation. Intermediate Degradation Products (Chlorate, Chlorite, and Nitrite) Were Not Detected.

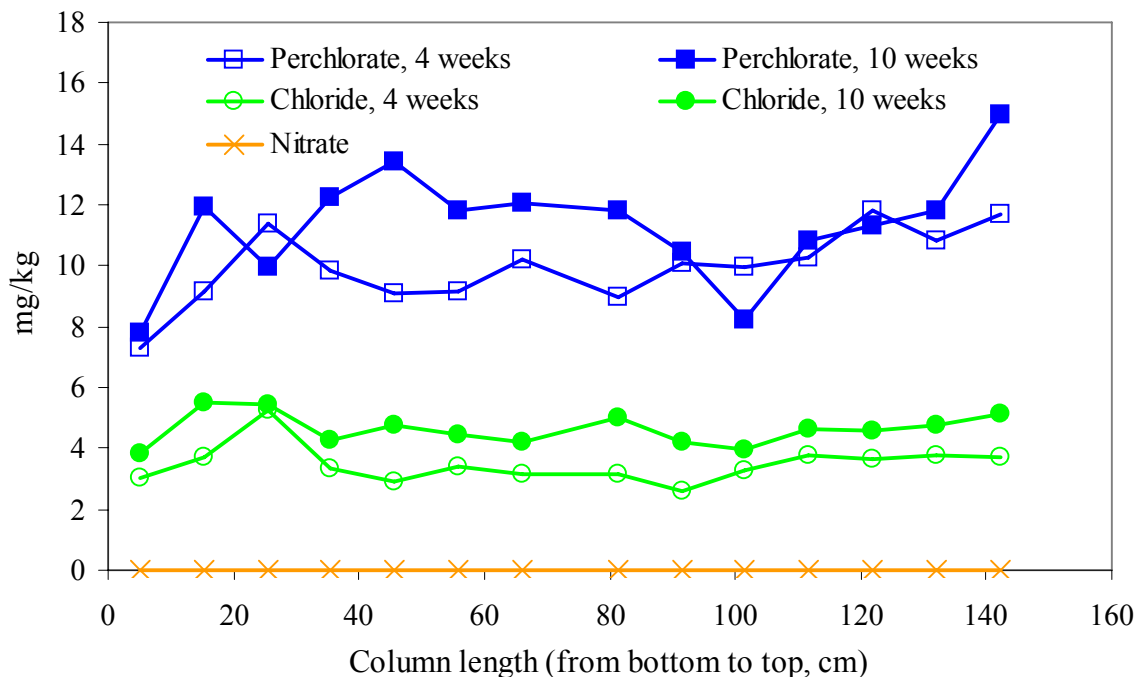

To quickly test if extended storage time and/or soil moisture was responsible for the lack of perchlorate degradation in the column experiments, a small batch test was performed in duplicate with the stored soil at two soil moisture contents: 10% and 16%. Similar to the setup of the microcosm experiments described in the treatability study report, soil from the field site was transferred in 10-gram (g) aliquots to four 150-mL glass serum bottles. After degassing the bottles, 0.44 mL or 1.19 mL de-ionized water was injected into the bottles to achieve 10 or 16% soil moisture, respectively. After withdrawing an equivalent amount of headspace, 13570 μ L pure hydrogen gas was injected into each bottle to achieve the same hydrogen concentration as the "high concentration" Microcosm tests. Carbon dioxide was not added to the microcosms to better mimic conditions of columns #1 and #2. The bottles were incubated in the dark at room temperature for a total of 3 weeks. No significant perchlorate reduction was observed in bottles with 10% soil moisture after 21 days of incubation; however, in bottles with 16% soil moisture, partial perchlorate reduction (1.32 ± 0.09 mg/kg or 14.6% perchlorate reduced) was observed during this same time period (**Figure 4-11**). These results indicate that the perchlorate reducing bacteria were still active in the stored soil, and that the higher moisture content promoted perchlorate reduction. A significantly higher rate of perchlorate reduction was observed in the original Microcosms with hydrogen and carbon dioxide at 16% soil moisture, in which 94% of the soil perchlorate was reduced in 21 days (see Section 3.0). This small batch test, therefore, does not rule out the possibility that extended storage and/or lack of carbon source negatively

affected perchlorate reduction in the column experiments. It does demonstrate, however, that soil moisture contents greater than 10% are needed to promote significant perchlorate reduction in this aged soil. Had the column experiments been performed with 16% soil moisture, it is reasonable to assume that perchlorate reduction would have been observed.

Figure 4-11 Hydrogen, Perchlorate, and Soil Moisture Concentrations in Hydrogen Microcosms with 10% or 16% Soil Moisture after 21 Days of Incubation. Intermediate Degradation Products (Chlorate, Chlorite, and Nitrite) Were Not Detected.

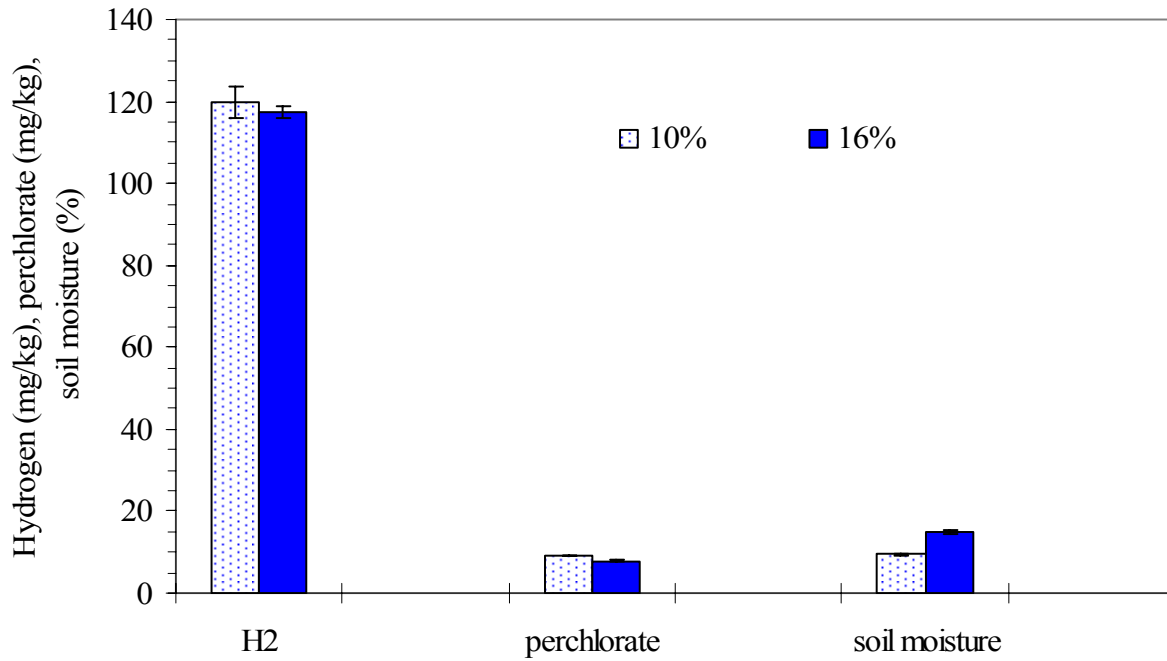

5.0 Air Injection Test

5.1 Introduction and Method

An air injection test was conducted at the IRCTS-PBA site using the newly installed injection well (CDM-INJ1) and piezometer (CDM-P1) in combination with the two existing wells at the site (SVS1A and SVS2). The objectives of the air injection test were to:

- Estimate the corresponding backpressures for various gas flow rates; and
- Estimate the pneumatic zone of influence of gas injection;

An air compressor was used to inject air into injection well CDM-INJ1 at different flow rates. Pressures were measured at the injection well head and at the different monitoring points in CDM-P1, SVS-1A, and SVS-2. The flow rates were tested in a series of steps from lowest to highest. Wellhead pressure was recorded using a pressure gauge. Actual flow rates to the injection well were controlled/measured using an air velocity meter, pressure regulator, and globe valve. Pressures were allowed to stabilize prior to increasing flow to the next level.

5.2 Results

Figure 5-1 shows the effect of air injection flow rate on pressures at the injection well (CDM-INJ1) and the piezometers at an approximate elevation of 120 feet above mean sea level (ft amsl) which corresponded to about 50 ft bgs (see **Figure 2-6**). The data show minimal pressure at the injection well (5 inches water column or less) and a positive effective of air injection on the piezometers located up to 84 feet from the injection well.

Figure 5-1 Effect of Air Injection Flow on Pressure at 120 ft amsl.

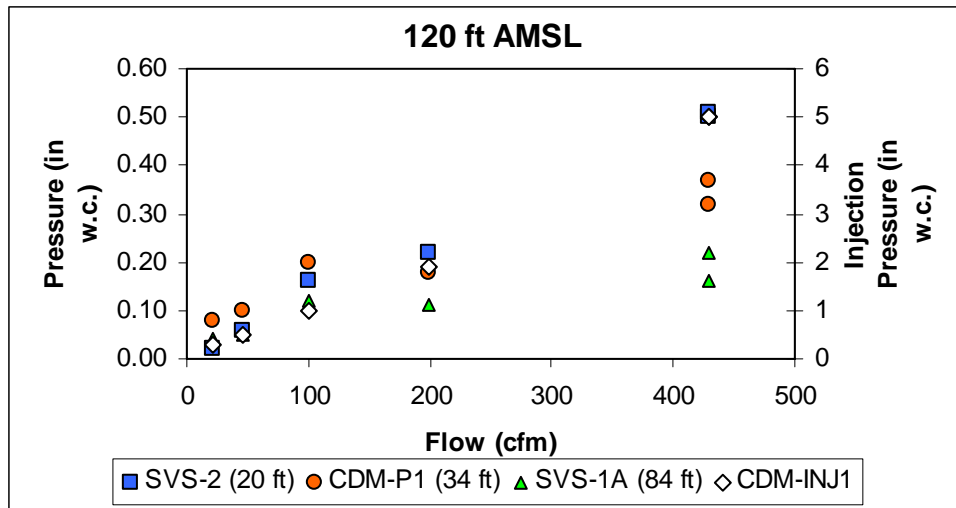

Figure 5-2 shows the relationship between pressure measured at each piezometer and distance for various flow rates. Log-linear relationships between these parameters were observed at the greater flow rates (r^2 greater than 0.96) in accordance with the one-dimensional, steady-state

equation for compressible, radial flow modified for gas injection (U. S. Army Corps of Engineers, 1999; U. S. Army Corps of Engineers, 2002):

$$P_2 - P_1 = \frac{Q_v \mu}{4\pi b k_a} \ln\left(\frac{r_1}{r_2}\right),$$

where P is the absolute pressure, Q_v is the flow rate, μ is the viscosity, b is the well screen length, k_a is the permeability, and r is the distance (radius) from the injection well. The subscripts 1 and 2 refer to individual monitoring points located different distances away from the injection well. The average permeability (k) based on these data was calculated to be $5.6E-4 \pm 0.9E-4$ cm² permeability at 120 ft amsl. This permeability is high and typically associated with unconsolidated gravels. Because of this high permeability, the radius of pneumatic influence at the maximum flow rate of 420 cfm was determined to be at least 84 ft. Pneumatic effects were observed at a distance of 34 ft at the lowest flow rate tested – 21 cfm.

Pneumatic effects were observed at elevations down to about 120 ft amsl or about 50 ft bgs. Based on this result, the remaining injection wells and piezometers will be installed only to a depth of 50 ft bgs rather than 70 ft bgs.

Figure 5-2 Relationship between Distance from Injection Well CDM-INJ1 and Piezometer Pressure at 120 ft amsl.

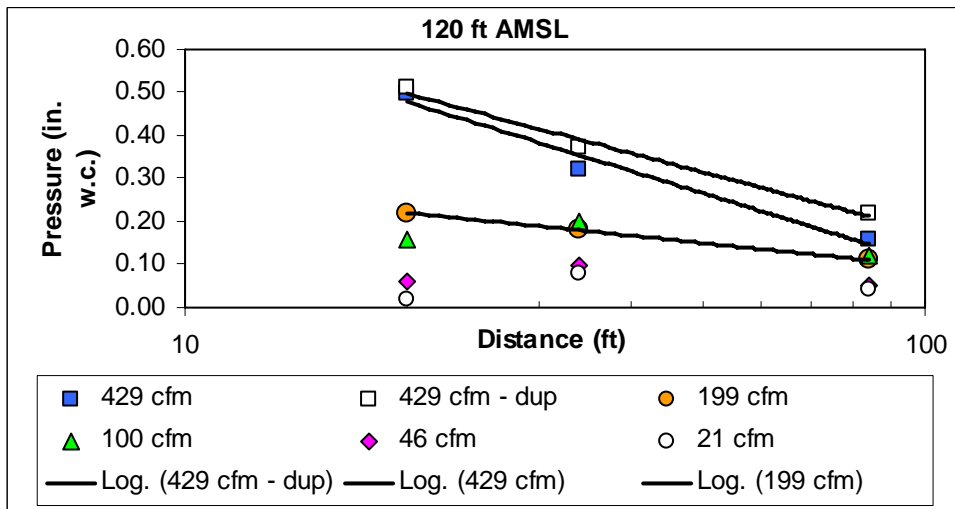

Figure 5-3 Effect of Air Flow on Pressure at Piezometer SVS-2.

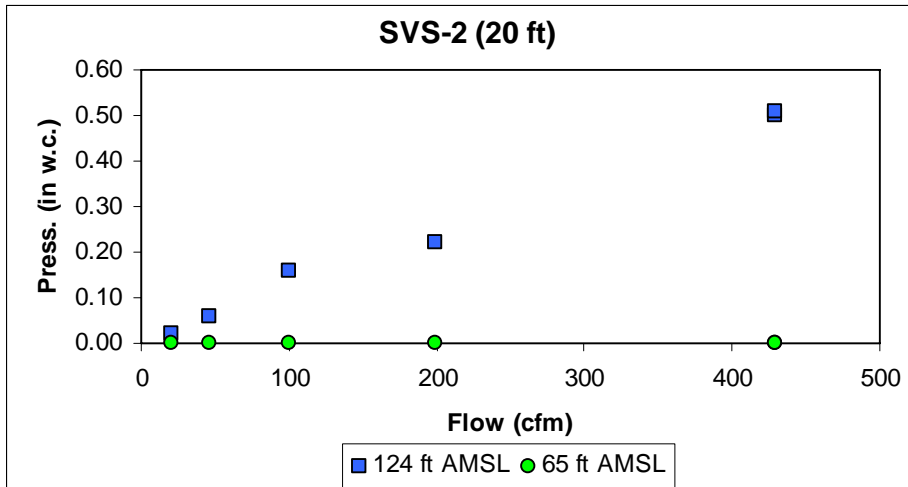

Figure 5-4 Effect of Air Flow on Pressure at Piezometer CDM-P1.

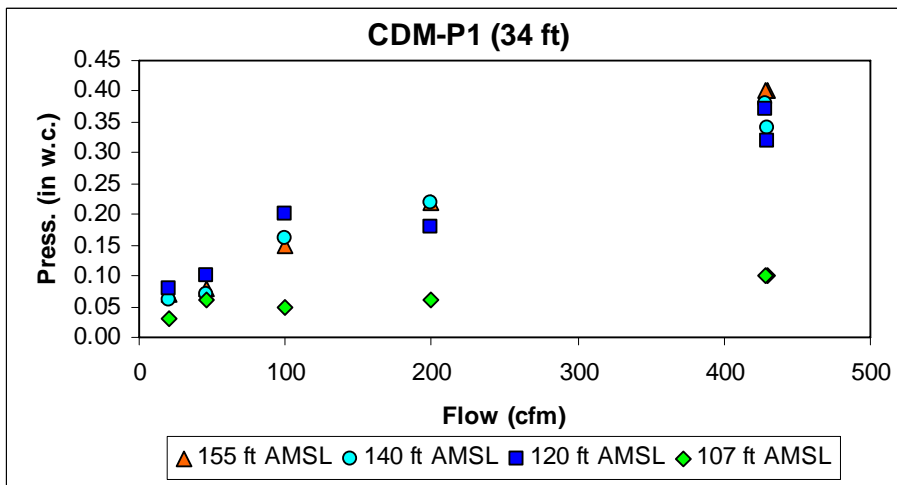
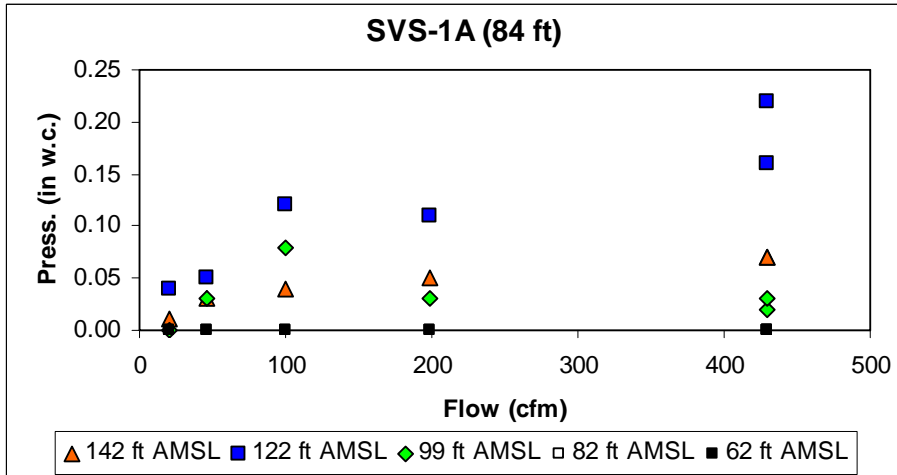

Figure 5-5 Effect of Air Flow on Pressure at Piezometer SVS-1A.



6.0 Overall Data Assessment

This section presents a deviations from the work plan (CDM, 2006) and evaluations of data quality and the data quality objectives.

6.1 Deviations from the Work Plan

The following deviations from the work plan were made:

- Piezometer was constructed using 3/8-inch tubing with porous steel vapor probes rather than continuous multi-chamber tubing (CMT) as a cost-savings measure.
- The air injection test was conducted with a maximum flow of 429 cfm rather than 1,000 cfm because of equipment availability.
- Transport rates of ethyl acetate and hexene were not determined because these were not the best two electron donors. Rather, the transport rates of hydrogen and LPG were determined.
- The effective concentration of electron donor delivered to soil in the column studies was less than that used in the microcosm studies because of an observed lack of donor consumption.

6.2 Evaluation of Data Quality and Data Quality Objectives

The intended use of the data is determination of the design requirements for the technology demonstration and not regulatory compliance. The quality of the data with respect to precision, accuracy, representativeness, completeness, comparability, and sensitivity were suitable for their intended use.

The following decision rules and responses were established in the work plan:

- Decision Rule 1: Use the relationship between perchlorate concentrations and soil lithology to focus the GEDIT design in the Phase II Technology Demonstration Plan.
 - Perchlorate was observed in both fine-grained and coarse-grained soils. The soil moisture was generally greater in the fine-grained materials. Therefore, the technology demonstration will address both fine-grained and coarse-grained soils.
- Decision Rule 2: Use the pneumatic zone of influence data to design the injection well and piezometer spacing in the Phase II Technology Demonstration Plan.
 - The pneumatic zone of influence data were used to design injection wells with a 20-foot spacing and with piezometers spaced in from 5 to 25 feet away from the injection wells.
- Decision Rule 3: Use the flow-backpressure data in combination with the pneumatic zone of influence data to specify the gas injection equipment for the Phase II Demonstration.

- Minimal backpressure was observed during injection therefore minimal gas injection pressure is required. Pneumatic influences were observed at flow rates as low as 21 cfm (i.e., the lowest flow rate tested). Therefore, the gas injection equipment will be capable of operating at flow rates of 10 to 30 cfm per well.
- Decision Rule 4: Select the best electron donors based on extent and rate of perchlorate biodegradation in site soil for further evaluation in the treatability study. Also use the microcosm data to select the rate of electron donor injection for the column test to ensure that stoichiometric requirements for biological reduction are satisfied.
 - Hydrogen and LPG were observed to be the best electron donors with respect to effectiveness. Two column studies were conducted – One contained hydrogen and the other contained hydrogen and LPG as electron donors. The effective concentration of electron donor that was delivered to soil in the column was less than in the microcosm studies because of an observed lack of donor consumption.
- Decision Rule 5: Select the two best electron donors for column biodegradation tests based on the results of Decision Rule 4 and the electron donor transport rates estimated using the columns.
 - Hydrogen and LPG were selected as the electron donors for further use.
- Select one or both of the electron donors identified in decision rule 5 to be used in the Phase II demonstration. The selected electron donors should have demonstrated ability to promote perchlorate biodegradation in the microcosm and column systems. Also consider potential for regulatory acceptance, engineering considerations, and cost when deciding which electron donors to use in Phase II.
 - Both hydrogen and LPG were observed to be the best electron donors with respect to effectiveness, handling, and cost. A mixture of these electron donors was therefore selected for the Phase II technology demonstration. Perchlorate destruction was only observed microcosm tests, but this may have due to age of the soil used for the column tests or other factors that are not representative of field conditions.

7.0 Conclusions

The following conclusions are based on the results of this treatability test:

- Soil borings completed at the site indicate that sufficient perchlorate (i.e., greater than 1 mg/kg) is present in soil for the purposes of this demonstration. Soil moisture ranges from 7 to 16% in non-clayey/silty soil where gas transport is expected to be most effective. Nitrate is present at detectable but relatively low concentrations. Soil is generally comprised of sands and gravels with some clay and silt at shallow and deeper zones.
- The microcosm study demonstrated that hydrogen/carbon dioxide and propane (LPG) were capable of promoting nitrate and perchlorate biodegradation. Biodegradation was observed at 16% moisture but not at 6% moisture. These data indicate that, as expected, moisture will be an important parameter affecting the rate and extent of perchlorate biodegradation. Hexene was partially capable of promoting perchlorate biodegradation and ethyl acetate was not capable of promoting perchlorate biodegradation. Based on these results, a mixture of hydrogen, carbon dioxide, and LPG is recommended for the field demonstration.
- The column studies demonstrated that, as expected, hydrogen and LPG were effectively transported through soil. Over time, no evidence of hydrogen “floating” was observed. Perchlorate biodegradation was not observed. However, supplemental microcosm studies indicated that either the soil moisture was too low or the soil used for the column tests was too old to support biodegradation.
- The air injection test demonstrated a high permeability that was consistent with the soil lithology. The pneumatic radius of influence was at least 30 feet and possibly as great as 80 feet. Relatively low flow rates were capable of promoting pneumatic influences at reasonable distances away from the injection well.

8.0 References

Aerojet Environmental Operations and HSI GeoTrans, Inc. 2000. Remedial Investigation Report for the Vadose Zone at the Propellant Burn Area. Inactive Rancho Cordova Test Site. Rancho Cordova, California. May.

American Public Health Association, American Water Works Association, and Water Environment Federation: 1998. Total, Fixed, and Volatile Solids in Solid and Semisolid Samples (Method 2540 G). *Standard Methods for the Examination of Water and Wastewater*, 20th ed., American Public Health Association (APHA), Washington D. C., pp. 2-59.

American Society for Testing and Materials (ASTM), 1999. Standard Test Method for Laboratory Determination of Water (Moisture) Content of Soil and Rock by Mass. Designation: D 2216-98. *The Annual Book of ASTM Standards*.

BioCycle, 2004. Hydrogen by Microorganisms. Reader Q & A. *BioCycle* 45(1):13.

Cheong, D-Y and Hansen, C. L., 2006. Bacterial Stress Enrichment Enhances Anaerobic Hydrogen Production in Cattle Manure Sludge. *Appl Microbiol Biotechnol* 72:635-643.

Doyon, G., Gagnon, J., Toupin, C., and Castaigne, F., 2006. Gas Transmission Properties of Polyvinyl Chloride (PVC) Films Studied Under Subambient and Ambient Conditions for Modified Atmosphere Packaging Applications. *Packaging Technology and Science* 4(3):157-165.

Envirogen Inc. 2002. In Situ Bioremediation of Perchlorate. SERDP Project CU-1163 Final Report. May 21.

http://www.epa.gov/safewater/contaminants/dw_contamfs/nitrates.html

Evans, P. J., and Trute, M. M., 2006. In Situ Bioremediation of Nitrate and Perchlorate in Vadose Zone Soil for Groundwater Protection Using Gaseous Electron Donor Injection Technology. *Water Environment Research* 78(13):2436-2446.

Hoponick, J. R., 2006. Status Report on Innovative *In Situ* Remediation Technologies Available to Treat Perchlorate-Contaminated Groundwater. National Network for Environmental Management Studies Fellow.

Kroon, A. G. M. and van Ginkel, C. G. 2004. Biological Reduction of Chlorate in a Gas-Lift Reactor Using Hydrogen as an Energy Source. *J. Environ. Qual.* 33:2026-2029.

Kwon, S. and Pignatello, J. J. 2005. Effect of Natural Organic Substances on the Surface and Adsorptive Properties of Environmental Black Carbon (Char): Pseudo Pore Blockage by Model

Lipid Components and its Implications for N-2-probed Surface Properties of Natural Sorbents. *Environ. Sci. Technol.* 39(30): 7932-7939.

Logan, B. E., Zhang, H., Mulvaney, P., Milner, M. G., Head, I. M., and Unz, R. F. 2001. Kinetics of Perchlorate- and Chlorate-Respiring Bacteria. *Applied and Environmental Microbiology* 37(6): 2499-2506.

Miller, J. P., and Logan, B. E., 2000. Sustained Perchlorate Degradation in an Autotrophic, Gas-Phase, Packed-Bed Bioreactor. *Environ. Sci. Technol.* 34:3018-3022.

Nerenberg, R., Rittmann, B. E., and Najm, I., 2002. Perchlorate Reduction in a Hydrogen-Based Membrane-Biofilm Reactor. *Journal AWWA*. November 2002, 103-114.

Nerenberg, R., Kawagoshi, Y., Rittmann, B.E. 2006. Kinetics of a Hydrogen-Oxidizing, Perchlorate-Reducing Bacterium. *Water Research* 40(2006):3290-3296.

Nozawa-Inoue, M., Scow, K. M., and Rolston, D. E., 2005. Reduction of Perchlorate and Nitrate by Microbial Communities in Vadose Soil. *Applied and Environmental Microbiology*, 71(7):3928-3934.

Nzengung, V. A., Das, K. C., and Kastner, J. R. 2003. Pilot Scale In-Situ Bioremediation Of Perchlorate-Contaminated Soils At The Longhorn Army Ammunition Plant. *Final Report on Perchlorate Remediation at LHAAP*. Department of Geology. And Department of Biological and Agricultural Engineering. The University of Georgia, Athens, GA 30602-4435.

Poulsen, T. G., Moldrup, P., de Jonge, L. W., and Komatsu, T. Colloid and Bromide Transport in Undisturbed Soil Columns: Application of Two-Region Model. *Vadose Zone J.*, 5(2): 649-656.

Shackelford, D. D., 1994. Critical Concepts for Column Testing. *Journal of Geotechnical Engineering* 120(10):1804-1828.

Spalding, R., Exner, M. 1993. Occurrence of Nitrate in Groundwater – A Review. *Journal of Environmental Quality*, 22: 392–402.

Squillace, P., Scott, J., Moran, M., Nolan, B., Kolpin, D. 2002. VOC's, Pesticides, Nitrate, and their Mixtures in Groundwater Used for Drinking Water in the United States. *Environmental Science and Technology*, 36: 1923–1930.

Tan, K., Anderson, T. A., and Andrew Jackson, W., 2003. Degradation Kinetics of Perchlorate in Sediments and Soils. *Water, Air, and Soil Pollution* 151:245-259.

U. S. Army Corps of Engineers. 1999. Engineering and Design. Multi-Phase Extraction. EM 1110-1-4010. June 1.

U. S. Army Corps of Engineers. 2002. Engineering and Design. Soil Vapor Extraction and Bioventing. EM 1110-1-4001. June 3.

U.S. Environmental Protection Agency, 1986. Guidelines Establishing Test Procedures for the Analysis of Pollutants (App. B, Part 136, Definition and Procedures for the Determination of the Method Detection Limit): U. S. Code of Federal Regulations, Title 40, CFR 51 FR 23703.

Appendix A-1
Well Report

WELL APPLICATION
AND PERMIT FORM

FOR OFFICE USE ONLY

DISAPPROVED APPROVED

APPROVED WITH CONDITIONS (See attachment)

By: SBW Date: 7/10/06 Date Received: 7/17/06 Total Fee: 7557.00 Permit Number: 29879

Grout Inspection By: _____ Date: _____ Date Issued: _____ SR Number: _____

Actual Well Depth: _____ Actual Grout Depth: _____ GPS #: _____ Receipt Number: 157183

Depth to first Water: _____ Well Destruction Inspection By: _____ Date: _____ Site Number: _____

Comments: _____

11505 Douglas Road

Inspecting Division: ENVIRONMENTAL HEALTH HAZARDOUS MATERIALS

SITE ADDRESS: INACTIVE RANCHO LORDOVA TEST SITE City: RANCHO LORDOVA Zip: 95742

Nearest Major Cross Street: WHITE ROCK ROAD Parcel Number: 072-0370-070-0000

Property Owner: AREOJET GENERAL CORPORATION Phone Number: 916-355-5161

Well Contractor: WDC License Number: 283326 OK Type: C-57

Contractor Address: PO BOX 141 / 9580 COUNTY RD 938 Expiration Date: 6-30-08

City: ZAMORA Zip: 95678 Phone: 800-813-3013 Well/Boring Identification Number: CDM-INJI

WORK TO BE PERFORMED: (License Required)

Construct Well (C-57) Repair/Modify Well or Pump (C-57, C-61, Class A) Test Hole Soil Boring With Destruction (C-57)

Install New Pump (C-57) Destroy Well (C-57) Inactivation Permit, (Owner Only)

Comments: _____ Other (state): _____

DISTANCE TO NEAREST: Leach Field: >500 FT Leach Pit: >500 FT Septic Tank: >500 FT Sewer Line: >500 FT

Stream, Ditch, Drainage Canal: >500 FT 100 Year Flood Plain: > 1 MILE

INTENDED USE: Domestic/Private Public Water System Irrigation Cathodic Protection Monitoring Extraction/Recovery Heat Exchanger Other (state) _____

DRILLING METHOD: Auger Cable Tool Driven Rotary Other (state) SOILC

CONSTRUCTION SPECIFICATIONS:

BOREHOLE: Diameter: 10-in Depth: 70 FT Gravel Pack: Yes No

CASING: Diameter: 6-in Depth: 70 FT

If Steel, Gauge: _____ Or Thickness: _____

If Plastic, Type: SLN 40 PVC (MUST MEET ASTM F-480)

If Conductor, Diameter: _____ Depth: _____

GROUT: Diameter: 10-in Depth: 8 FT Sealing Material: CEMENT BENTONITE GROUT

TRANSITION SEAL: Material: Bentonite chips Interval: est. 8-9 ft.

Comments: VADUSE ZONE INJECTION WELL FOR INSITU BIOREMEDIATION PILOT TEST

PUMP INSTALLATION/REPAIR: Contractor: _____ License Number: _____

Type of Pump: _____ Horse Power: _____ License Type: _____ Expiration Date: _____

WELL/TEST HOLE/ SOIL BORING DESTRUCTION: Diameter: _____ Total depth: _____ Depth to Water: _____

I will comply with all Codes, Rules and Regulations of the State and County pertaining to or regulating well construction/destruction, call for a grout/destruction inspection at least 24 hours prior to placement of sealing material, notify the Department within 5 days of the completion of my work so a final inspection can be made, and obtain final approval before placing the well in service.

Signature: SBW Property Owner Well Contractor

Print Name: DM TUDS Agent for Property Owner* Agent for Well Contractor* SBW

Company: CDM Phone: 916-567-9500 Field Phone # if Available: 916-708-3749

Mailing Address: 2245 GATEWAY OAKS STE 240 City, State, Zip: SACRAMENTO, CA 95833

A SITE PLAN **MUST** BE SUBMITTED WITH EACH APPLICATION
PERMIT EXPIRES ONE (1) YEAR FROM DATE ISSUED (UNLESS EXTENDED)

875-8524

WELL APPLICATION
AND PERMIT FORM

FOR OFFICE USE ONLY

DISAPPROVED APPROVED

APPROVED WITH CONDITIONS (See attachment)

By: SBW Date: 7/10/06 Date Received: 7/10/06 Permit Number: 29880

GROUT INSPECTION BY: _____ Date: _____ Date Issued: _____ SR Number: _____

Actual Well Depth: _____ Actual Grout Depth: _____ Total Fee: 6213.00 Receipt Number: 157183

Depth to first Water: _____ Well Destruction Inspection By: _____ Site Number: _____

Comments: _____

11505 Douglas Road

Inspecting Division: ENVIRONMENTAL HEALTH HAZARDOUS MATERIALS

SITE ADDRESS: INACTIVE PAVILION CONCRETE TEST SITE City: PANAMA CONCRETE Zip: 95742

Nearest Major Cross Street: WHITE ROCK ROAD Parcel Number: 072-0370-070-0000

Property Owner: AEROSOL GENERAL CORPORATION Phone Number: 916-355-5161

Well Contractor: WPC License Number: 283326 Type: L-57

Contractor Address: P.O. BOX 141 | 95800 CUNNINGHAM RD 93 B Expiration Date: 6-30-08

City: ZAMONA Zip: 95698 Phone: 916-813-3013 Well/Boring Identification Number: CDM-PI

WORK TO BE PERFORMED: (License Required)

Construct Well (C-57) Repair/Modify Well or Pump (C-57, C-61, Class A) Test Hole Soil Boring With Destruction (C-57)

Install New Pump (C-57) Destroy Well (C-57) Inactivation Permit, (Owner Only)

Comments: SEE ATTACHED Other (state): _____

DISTANCE TO NEAREST: Leach Field: > 500 FT Leach Pit: > 500 FT Septic Tank: > 500 FT Sewer Line: > 500 FT

Stream, Ditch, Drainage Canal: > 500 FT 100 Year Flood Plain: > 1 MILE

INTENDED USE: Domestic/Private Public Water System Irrigation Cathodic Protection Monitoring Extraction/Recovery Heat Exchanger Other (state) _____

DRILLING METHOD: Auger Cable Tool Driven Rotary Other (state) SOIL

CONSTRUCTION SPECIFICATIONS:

BOREHOLE: Diameter: 6" IN Depth: 70 FT Gravel Pack: Yes No

CASING: Diameter: 1.5" IN Depth: 70 FT

If Steel, Gauge: _____ Or Thickness: _____

If Plastic, Type: GMT MULTI-POINT (MUST MEET ASTM F-480)

If Conductor, Diameter: _____ Depth: _____

GROUT: Diameter: 6" IN Depth: 120 FT Sealing Material: CONCRETE BENTONITE GROUT

TRANSITION SEAL: Material: BENTONITE CHIPS Interval: 20-25 FT

Comments: PIEZOMETER

PUMP INSTALLATION/REPAIR: Contractor: _____ License Number: _____

Type of Pump: _____ Horse Power: _____ License Type: _____ Expiration Date: _____

WELL/TEST HOLE/ SOIL BORING DESTRUCTION: Diameter: _____ Total depth: _____ Depth to Water: _____

I will comply with all Codes, Rules and Regulations of the State and County pertaining to or regulating well construction/destruction, call for a grout/destruction inspection at least 24 hours prior to placement of sealing material, notify the Department within 5 days of the completion of my work so a final inspection can be made, and obtain final approval before placing the well in service.

Signature: TPM TUD Property Owner Well Contractor

Print Name: TPM TUD Agent for Property Owner* Agent for Well Contractor* SBW

Company: CDM Phone: 916-567-9500 Field Phone # if Available: 916-708-3749

Mailing Address: 2275 WAREWAY OAKS STE 240 City, State, Zip: SACRAMENTO CA 95833

Appendix A-2
Boring Logs



18581 Teller Avenue, Suite 200
Irvine, CA 92612
(949) 752-5452
(949) 752-1307 (FAX)

BORING/WELL CONSTRUCTION LOG

PROJECT NUMBER 4000-46738 BORING/WELL NUMBER CDM-INJ1
 PROJECT NAME Aerojet DATE DRILLED 07/31/06
 LOCATION Rancho Cordova, CA CASING TYPE/DIAMETER Sch 40 PVC/6-inch
 DRILLING METHOD Sonic SCREEN TYPE/SLOT 6-inch Sch 40 PVC/20 Slot
 SAMPLING METHOD Continuous Core GRAVEL PACK TYPE No. 3 Monterey Beach Sand
 GROUND SURFACE ELEVATION (FT MSL) NA GROUT TYPE/QUANTITY Bentonite Grout
 TOP OF CASING ELEVATION (FT MSL) NA STATIC WATER LEVEL (FT BELOW TOC) NA
 LOGGED BY T.Titus GROUND WATER ELEVATION (FT MSL) _____
 REMARKS _____

PID (ppm)	BLOW COUNTS	RECOVERY (inches)	SAMPLE ID.	EXTENT	DEPTH (ft. bgs)	U.S.C.S.	GRAPHIC LOG	LITHOLOGIC DESCRIPTION	CONTACT DEPTH	WELL DIAGRAM
0.0					5	ML		SILT: brown (10YR 4/3); 100% silt, firm, low plasticity; dry, no odor.		
0.0					10	CL		CLAY: dark yellowish brown (10YR 3/4); 100% clay, soft, high plasticity; moist, no odor.	10.0	
0.0					15	ML		SILT: brown (10YR 4/3); 100% silt, firm, low plasticity; moist, no odor.	13.0	
0.0					20	CL		CLAY: dark yellowish brown (10YR 3/4); 100% clay, soft, high plasticity; moist, no odor.	18.0	
0.0					25	GC		CLAYEY GRAVEL: brown (7.5YR 4/3); 60% gravel, well graded, fine and coarse grained, maximum diameter of 3 inches, angular to rounded; 30% clay, soft, medium plasticity; 10% cobbles, maximum diameter of 5 inches, subrounded to rounded; moist, no odor.	20.0	
0.0					30			SILTY SAND WITH GRAVEL: brown (7.5YR 4/3); 40% sand, well graded, fine to coarse grained, angular to rounded; 30% silt, very soft, non-plastic; 30% gravel, well graded, fine and coarse grained, maximum diameter of 3 inches, angular to rounded; trace cobbles, maximum diameter of 6 inches, rounded; moist, no odor.	25.0	
0.0					35			Cobbles from 35 to 38 feet below ground surface.		
0.0					40					

NEWGINT_AEROJET_042806.GPJ_NEWGINT.GDT_8/3/06

Continued Next Page



18581 Teller Avenue, Suite 200
 Irvine, CA 92612
 (949) 752-5452
 (949) 752-1307 (FAX)

BORING/WELL CONSTRUCTION LOG

PROJECT NUMBER 4000-46738 BORING/WELL NUMBER CDM-INJ1
 PROJECT NAME Aerojet DATE DRILLED 07/31/06

Continued from Previous Page

PID (ppm)	BLOW COUNTS	RECOVERY (inches)	SAMPLE ID.	EXTENT	DEPTH (ft. bgs)	U.S.C.S.	GRAPHIC LOG	LITHOLOGIC DESCRIPTION	CONTACT DEPTH	WELL DIAGRAM
0.0								SILTY SAND WITH GRAVEL: brown (7.5YR 4/2); 60% sand, well graded, fine to coarse grained, angular to subrounded; 20% silt, soft, non-plastic; 20% gravel, well graded, fine and coarse grained, maximum diameter of 3 inches, subangular to rounded; trace cobbles, maximum diameter of 5 inches, rounded; moist, no odor.		<p>Screen (10-70 ft bgs)</p> <p>Sand (8-70.5 ft bgs)</p>
0.0					45	SM				
0.0					50					
0.0					55					
0.0					60			SILTY SAND WITH GRAVEL: brown (7.5YR 4/2); 60% sand, well graded, fine to coarse grained, angular to subrounded; 20% silt, soft, non-plastic; 20% gravel, well graded, fine and coarse grained, maximum diameter of 3 inches, subangular to angular; moist, no odor.		
0.0					65					
0.0					70				70.5	
								Total depth of borehole was 70.5 feet below ground surface.		
					75					
					80					
					85					

NEWGINT_AEROJET_042806.GPJ_NEWGINT.GDT 8/3/06



18581 Teller Avenue, Suite 200
Irvine, CA 92612
(949) 752-5452
(949) 752-1307 (FAX)

BORING/WELL CONSTRUCTION LOG

PROJECT NUMBER 4000-46738
PROJECT NAME Aerojet
LOCATION Rancho Cordova, CA
DRILLING METHOD Sonic
SAMPLING METHOD Continuous Core
GROUND SURFACE ELEVATION (FT MSL) NA
TOP OF CASING ELEVATION (FT MSL) NA
LOGGED BY T.Titus
REMARKS _____

BORING/WELL NUMBER CDM-P1
DATE DRILLED 07/27/06
CASING TYPE/DIAMETER Poly Tubing/0.25-inch ID
SCREEN TYPE/SLOT 0.25-inch Stainless Steel Vapor Probe
GRAVEL PACK TYPE No. 3 Monterey Beach Sand
GROUT TYPE/QUANTITY Bentonite Grout
STATIC WATER LEVEL (FT BELOW TOC) NA
GROUND WATER ELEVATION (FT MSL) _____

PID (ppm)	BLOW COUNTS	RECOVERY (inches)	SAMPLE ID.	EXTENT	DEPTH (ft. bgs)	U.S.C.S.	GRAPHIC LOG	LITHOLOGIC DESCRIPTION	CONTACT DEPTH	WELL DIAGRAM
0.0					5	ML		SILT: yellowish brown (10YR 5/4); 100% silt, soft, non-plastic; dry; no odor.	6.0	
0.0					10	GM		GRAVELLY SILT: yellowish brown (10YR 5/4); 60% silt, soft, non-plastic; 40% gravel, well graded, fine and coarse grained, maximum diameter of 3 inches, subround to rounded; dry, no odor.	13.0	
0.0					15	GM		GRAVELLY SILT WITH SAND: brown (7.5YR 4/3); 50% silt, soft, non-plastic; 35% gravel, well graded, fine and coarse grained, maximum diameter of 3 inches, subangular to rounded; 15% sand, poorly graded, medium to coarse grained, subrounded; moist, no odor.	23.0	
0.0					25	GC		CLAYEY GRAVEL WITH SAND: dark yellowish brown (10YR 4/4); 45% gravel, well graded, fine and coarse grained, maximum diameter of 3 inches, subangular to rounded; 35% clay, soft, low plasticity; 20% sand, poorly graded, coarse grained, subrounded to rounded; moist, no odor.	34.0	
0.0					35	SP		SAND: pale brown (10YR 6/3); 100% sand, poorly graded, fine grained; dry, no odor.	35.0	
					40			CLAYEY GRAVEL WITH SAND: dark yellowish brown (10YR 4/4); 45% gravel, well graded, fine and coarse grained, maximum diameter of 3 inches, subangular to rounded; 35% clay, soft, low plasticity; 20% sand, poorly graded, coarse grained, subrounded to rounded; moist, no odor.		

Continued Next Page



18581 Teller Avenue, Suite 200
Irvine, CA 92612
(949) 752-5452
(949) 752-1307 (FAX)

BORING/WELL CONSTRUCTION LOG

PROJECT NUMBER 4000-46738

BORING/WELL NUMBER CDM-P1

PROJECT NAME Aerojet

DATE DRILLED 07/27/06

Continued from Previous Page

PID (ppm)	BLOW COUNTS	RECOVERY (inches)	SAMPLE ID.	EXTENT	DEPTH (ft. bgs)	U.S.C.S.	GRAPHIC LOG	LITHOLOGIC DESCRIPTION	CONTACT DEPTH	WELL DIAGRAM
0.0					45.0	GC			45.0	<ul style="list-style-type: none"> Poly Tubing (0-18, 0-33, 0-48, and 0-68 ft bgs)
0.0					47.5	SM		SILTY SAND: dark yellowish brown (10YR 4/4); 70% sand, poorly graded, fine to medium, subrounded to subangular; 30% silt, firm, non-plastic; moist, no odor.	47.5	<ul style="list-style-type: none"> Sand (47-49.6 ft bgs) Vapor Probe (48-48.5 ft bgs)
0.0					52.0	SM		SILTY SAND WITH GRAVEL: dark yellowish brown (10YR 4/4); 40% sand, well graded, fine to coarse grained, subangular to subrounded; 30% silt, firm, non-plastic; 30% gravel, well graded, fine and coarse grained, maximum diameter of 3 inches, angular to rounded; moist, no odor.	52.0	
0.0					62.0	SC		CLAYEY SAND WITH GRAVEL: dark yellowish brown (10YR 4/4); 40% sand, well graded, fine to coarse grained, subangular to subrounded; 30% clay, firm, low plasticity; 30% gravel, well graded, fine and coarse grained, maximum diameter of 3 inches, angular to rounded; moist, no odor.	62.0	<ul style="list-style-type: none"> Bentonite (49.6-67 ft bgs)
0.0					65.0	SM		SILTY SAND WITH GRAVEL: dark yellowish brown (10YR 4/4); 40% sand, well graded, fine to coarse grained, subangular to subrounded; 30% silt, firm, non-plastic; 30% gravel, well graded, fine and coarse grained, maximum diameter of 3 inches, angular to rounded; moist, no odor.	65.0	<ul style="list-style-type: none"> Sand (67-69 ft bgs) Vapor Probe (68-68.5 ft bgs)
0.0					72.0			Total depth of borehole was 72 feet below ground surface.	72.0	<ul style="list-style-type: none"> Bentonite (69-72 ft bgs)
					75					
					80					
					85					

NEWGINT_AEROJET_042806.GPJ_NEWGINT.GDT 8/3/06

Appendix A-3
Microcosm Test Data

A.1 Microcosm Setup Details

Test #	Design			soil			moisture			Electron Donor			
	Electron Donor	Electron donor conc. (mg/kg)	Soil moisture	mass per bottle (g)	No. of bottles	Total mass soil per batch (g)	Final (%)	Initial (%)	Water Added per batch (mL)	Name	Final Conc (mg/kg)	Pure e.d. injected into each bottle (µL)	CO2 injected into each bottle (uL)
1*	H2	34	7%	10	18	180	7%	7.0%	0.00	H2	34	4046.8	2023.4
2*	Ethyl acetate	150	7%	10	18	180	7%	7.0%	0.00	Ethyl acetate	150	1.7	
3	1-Hexene	80	7%	10	9	90	7%	7.0%	0.00	1-Hexene	80	1.2	
4	LPG	75	7%	10	9	90	7%	7.0%	0.00	LPG	75	408.9	
5	H2	114	7%	10	9	90	7%	7.0%	0.00	H2	114	13568.7	6784.3
6*	Ethyl acetate	501	7%	10	18	180	7%	7.0%	0.00	Ethyl acetate	501	5.6	
7*	1-Hexene	265	7%	10	18	180	7%	7.0%	0.00	1-Hexene	265	3.9	
8	LPG	250	7%	10	9	90	7%	7.0%	0.00	LPG	250	1363.0	
9	H2	34	16%	10	9	90	16%	7.0%	9.64	H2	34	4046.8	2023.4
10	Ethyl acetate	150	16%	10	9	90	16%	7.0%	9.64	Ethyl acetate	150	1.7	
11*	1-Hexene	80	16%	10	18	180	16%	7.0%	19.29	LPG	80	1.2	
12*	LPG	75	16%	10	18	180	16%	7.0%	19.29	Propane	75	408.9	
13*	H2	114	16%	10	18	180	16%	7.0%	19.29	H2	114	13568.7	6784.3
14	Ethyl acetate	501	16%	10	9	90	16%	7.0%	9.64	Ethyl acetate	501	5.6	
15	1-Hexene	265	16%	10	9	90	16%	7.0%	9.64	1-Hexene	265	3.9	
16*	LPG	250	16%	10	18	180	16%	7.0%	19.29	LPG	250	1363.0	
17	Negative control	0	16%	10	9	90	16%	7.0%	9.64	None	0	0.0	
18	Positive control	436	16%	10	9	90	16%	7.0%	9.64	Ethanol	436	5.5	

* = Tests that were randomly chosen to be run in duplicate.

A.2 Microcosm Tests Data

A.2.1 Test 1: 7% moisture, 34 mg/kg H₂

		Time (days)												
		0	7	14	21	28	35	42	49	56	63	91	144	203
Perchlorate	average (ppm)	11.42	10.1	-	9.7	-	10.1	-	11.21	-	10.05	9.46	12.021	12.84
	std. dev.	2.94	0.39	-	0.35	-	0.13	-	1.22	-	0.1	2.5	0.5215	1.265
Chloride	average (ppm)	2.7	1.92	-	2.54	-	3.54	-	5.81	-	5.49	2.7	5.53	5.29
	std. dev.	0.08	0.03	-	0.58	-	0.76	-	0.27	-	2.7	1.04	0.28	0.8
Nitrate	average (ppb)	J	J	-	J	-	J	-	J	-	J	J	J	0
	std. dev.	-	-	-	-	-	-	-	-	-	-	-	-	0
Hydrogen	average (mg/kg)	32.91	31.28	-	33.86	-	62.63	67.7	73.6	62.44	99.28	78.931	76.9	80.106
	std. dev.	0.31	4.62	-	0.16	-	0.67	2.75	2.5	1.18	2.04	4.93	0	1.48
CO ₂	average (ppmv)	31.49	21.638	-	24.315	-	67.3	-	20.92	-	25.85	61.29	63.26	58.62
	std. dev.	0	0	-	0	-	0	-	0	-	0	0	0	0
moisture	average (%)	6.56	7.79	-	6.98	-	6.49	-	6.39	-	7.12	6.87	8.71	6.64
	std. dev.	0.15	0.119	-	1.37	-	1.1	-	0.25	-	0.31	0.56	0	0.57
pH	average	7.24	6.45	-	6.69	-	7.2	-	7.19	-	7.2	7.19	7.14	7.02
	std. dev.	0.05	0.05	-	0.01	-	0.08	-	0.04	-	0.15	0.08	0	0.08

J = below the detection limit (the substance in question was detected, but at levels below that which can be accurately characterized by the test method).

Test1: 7% moisture, 34mg/kg H2

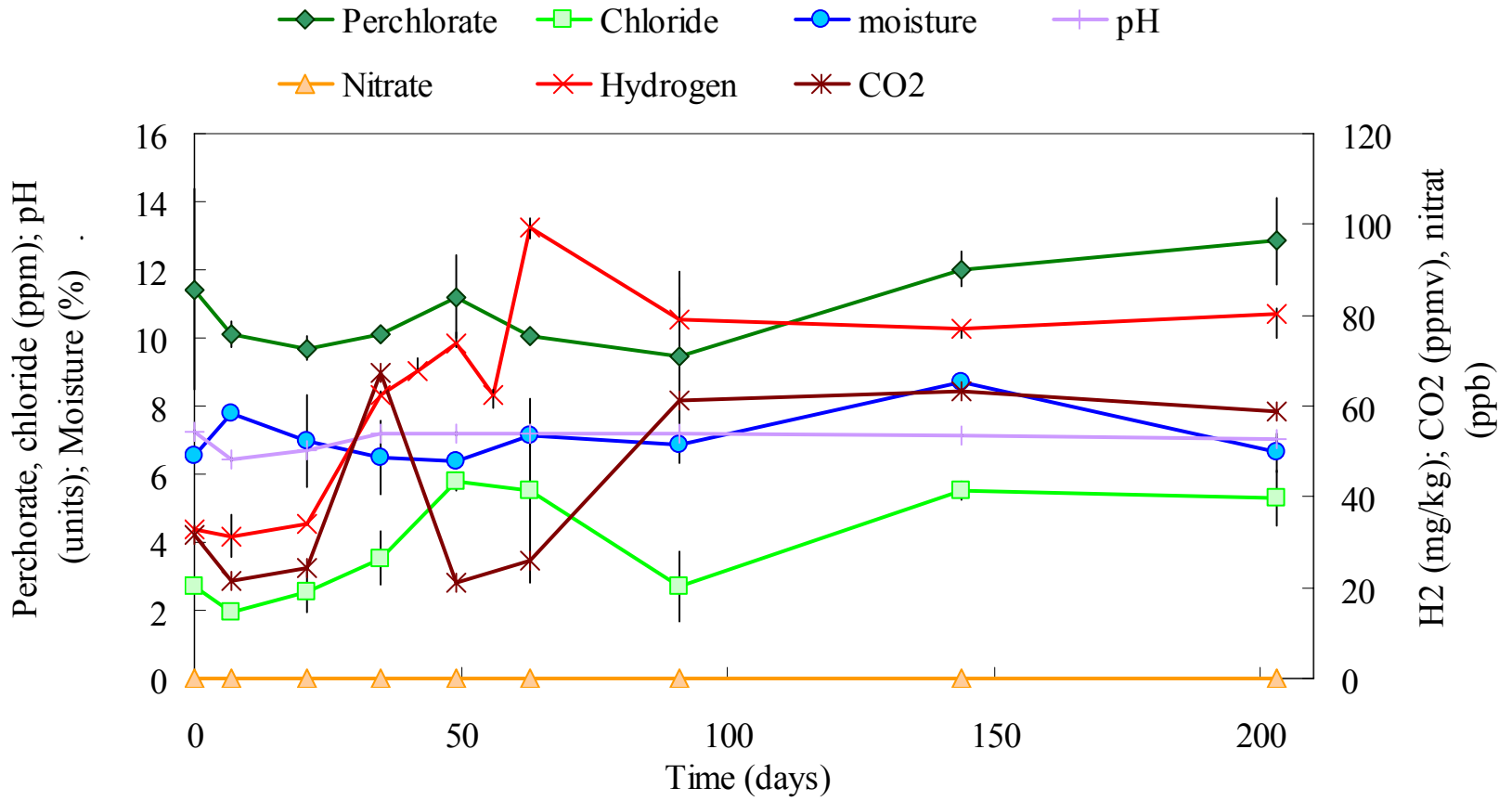

A.2.2 Test 2: 7% moisture, 150 mg/kg ethyl acetate

		Time (days)													
		0	7	14	21	28	35	42	49	56	63	70	91	143	202
Perchlorate	average (ppm)	11.06	11.14	-	10.68	-	10.72	-	10.29	-	10.45	-	10	12.404	11.68
	std. dev.	0.26	1.05	-	0.14	-	0.55	-	1.94	-	0.19	-	1.68	0.2755	1.14
Chloride	average (ppm)	1.75	2.33	-	2.83	-	1.62	-	5.06	-	2.79	-	3.18	4.99	5.8
	std. dev.	1.17	0.86	-	0.17	-	0.29	-	0.61	-	0.14	-	0.81	0.77	0.32
Nitrate	average (ppb)	J	J	-	J	-	J	-	J	-	J	-	J	J	0
	std. dev.	-	-	-	-	-	-	-	-	-	-	-	-	-	0
Ethyl Acetate	average (mg/kg)	53.35	28.35	-	8.31	0.11	4.43	0.02	10.22	0	0	1.36	0	0	0
	std. dev.	2.14	5.34	-	6.9	0.14	5.84	0	14.45	0	0	0.09	0	0	0
CO ₂	average (ppmv)	0	0	-	0	-	0	-	0	-	0	-	0	0	0
	std. dev.	0	0	-	0	-	0	-	0	-	0	-	0	0	0
moisture	average (%)	6.55	7.3	-	6.81	-	6.41	-	7.86	6.13	6.83	-	6.49	7.7	7.37
	std. dev.	0.54	1.06	-	0.32	-	0.88	-	0.92	0.08	0.37	-	0.5	0.24	0.3
pH	average	6.71	6.63	-	6.79	-	6.64	-	6.7	-	6.38	-	7.17	7.02	6.81
	std. dev.	0.01	0.08	-	0.11	-	0.16	-	0.04	-	0.03	-	0.06	0.13	0.04

J = below the detection limit (the substance in question was detected, but at levels below that which can be accurately characterized by the test method).

Test 2: 7% moisture, 150mg/kg Ethyl Acetate

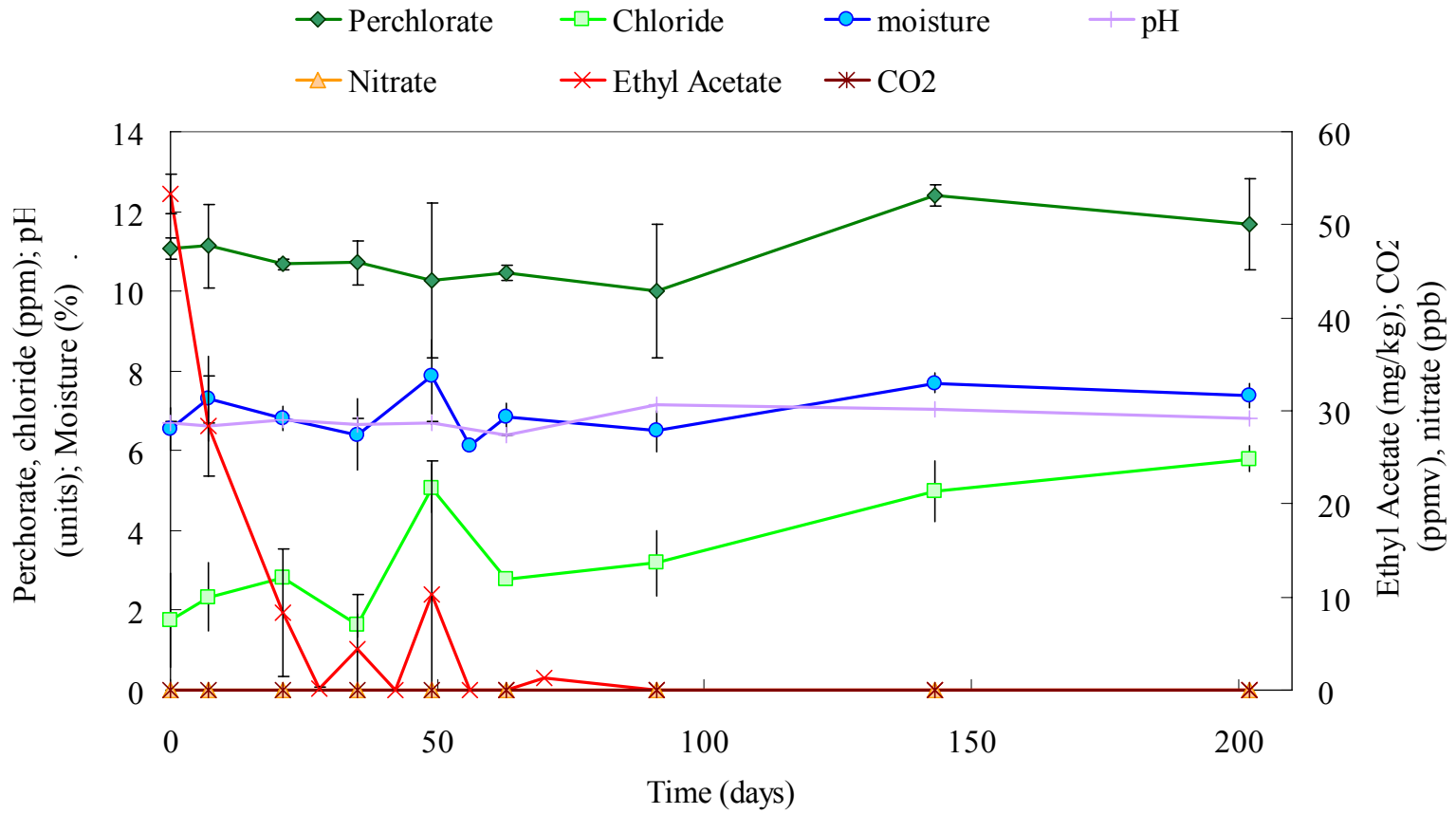

A.2.3 Test 3: 7% Moisture, 80 mg/kg 1-hexene

		Time (days)										
		0	7	14	21	28	35	42	49	77	125	185
Perchlorate	average (ppm)	10.64	11.21	-	10.16	-	10.9	-	11.86	10.86	11.86	10.44
	std. dev.	0.01	0.01	-	0.14	-	0.29	-	0	1.05	0.55	1.25
Chloride	average (ppm)	1.37	3.02	-	3.99	-	4.67	-	4.87	3.22	7.64	3.59
	std. dev.	1.93	0.02	-	0.07	-	0.29	-	0	0.54	0.8	0.62
Nitrate	average (ppm)	J	J	-	J	-	J	-	J	J	J	0
	std. dev.	0	-	-	-	-	-	-	-	-	-	0
1-Hexene	average (mg/kg)	9.96	78.432	100.738	110.49	63.67	131.351	145.61	29.04	29.03	114.541	111.087
CO ₂	average (ppmv)	0	0	-	0	-	0	-	0	0	0	0
moisture	average (%)	5.95	5.96	-	7.56	-	6.72	-	6.39	6.99	6.01	5.55
pH	average	6.89	6.54	-	6.84	-	7.04	-	7.44	7.25	6.98	7.29

J = below the detection limit (the substance in question was detected, but at levels below that which can be accurately characterized by the test method)

Test 3: 7% moisture, 80mg/kg 1-Hexene

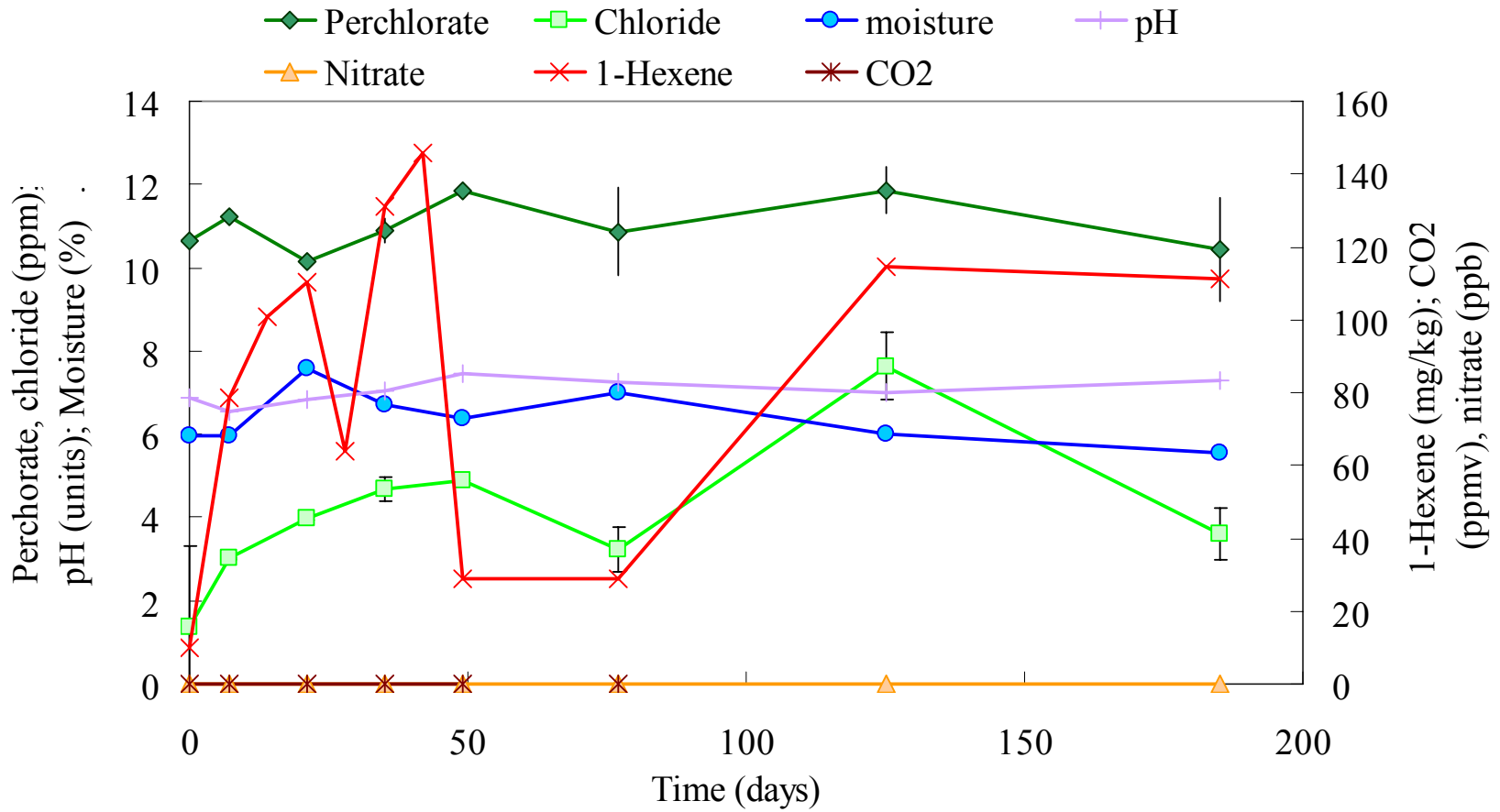

A.2.4 Test 4: 7% Moisture, 75 mg/kg LPG

		Time (days)										
		0	7	14	21	28	35	42	49	77	124	184
Perchlorate	average (ppm)	9.73	10.81	-	11.01	-	8.03	-	11.81	10.36	12.4	11.29
	std. dev.	0.52	0.01	-	0.71	-	5.23	-	0	1.3	0.03	0
Chloride	average (ppm)	3.78	4.22	-	5.23	-	2.88	-	5.18	4.13	4.76	4.58
	std. dev.	0.04	0.02	-	0.32	-	2.3	-	0	0.81	0.29	0
Nitrate	average (ppb)	J	J	-	J	-	J	-	J	J	J	0
	std. dev.	-	-	-	-	-	-	-	-	-	-	0
LPG	average (mg/kg)	58.152	221.69	235.62	176.01	253.02	263.4	84.653	312.976	356.734	283.645	221.692
CO ₂	average (ppmv)	0	0	-	0	-	0	-	0	0	0	0
moisture	average (%)	5.41	5.56	-	4.88	-	6.1	-	5.72	5.67	6.94	6.32
pH	average	7.03	7.17	-	7.18	-	6.91	-	6.99	7.2	7.01	7.32

J = below the detection limit (the substance in question was detected, but at levels below that which can be accurately characterized by the test method)

Test 4: 7% moisture, 75mg/kg LPG

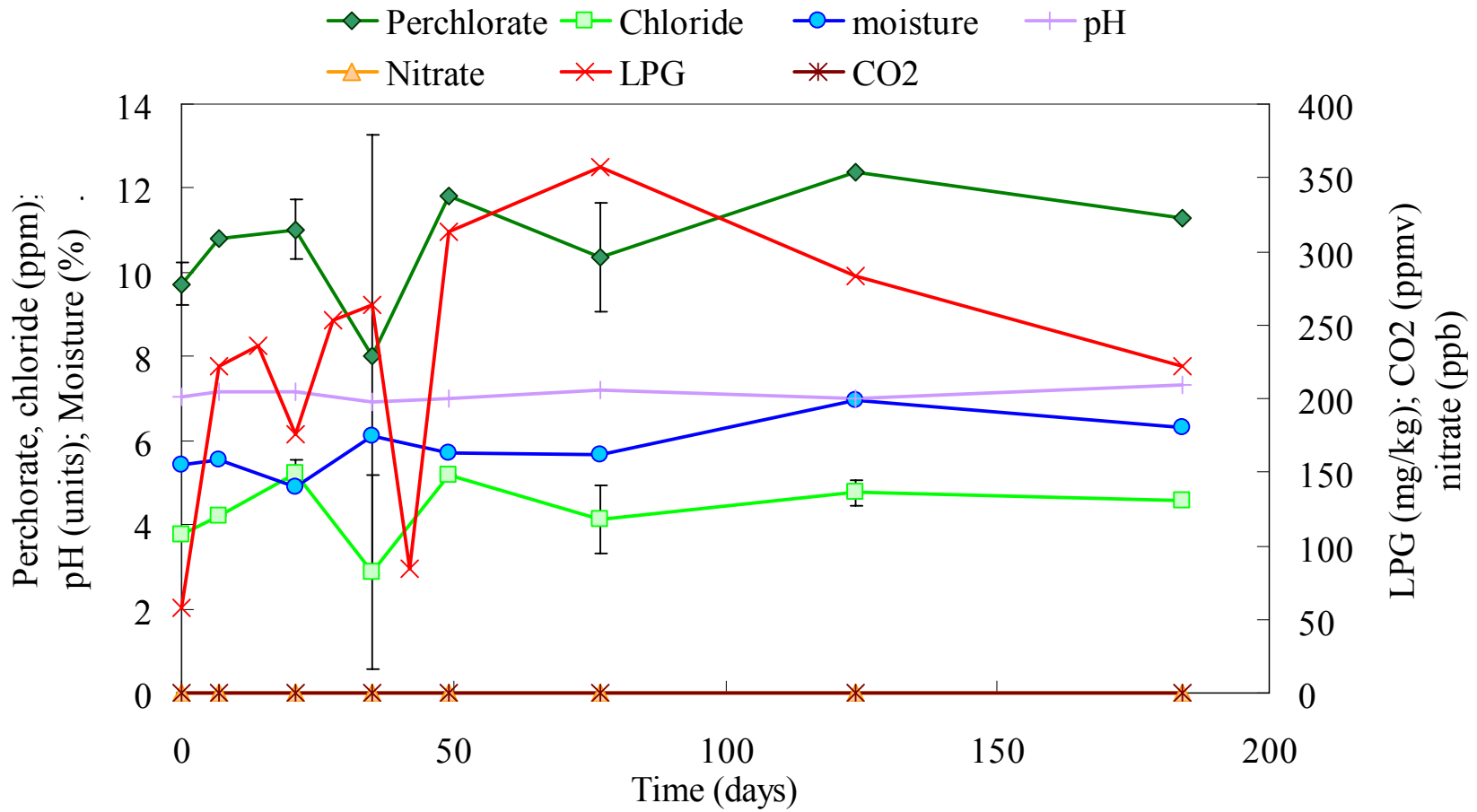

A.2.5 Test 5: 7% Moisture, 114 mg/kg H₂

		Time (days)										
		0	7	14	21	28	35	42	49	77	128	187
Perchlorate	average (ppm)	10.76	11.7	-	9.48	-	11.3	-	10.91	9.82	12.4176	12.98
	std. dev.	0.04	0.04	-	0.1	-	0.54	-	0.03	2.75	0.5	1.13
Chloride	average (ppm)	2.79	3.17	-	2.53	-	5.28	-	3.93	3.68	4	5.56
	std. dev.	0.05	0.03	-	0.6	-	0.58	-	0.09	1.57	0.16	0.1
Nitrate	average (ppb)	J	J	-	J	-	J	-	J	J	J	0
	std. dev.	-	-	-	-	-	-	-	-	-	-	-
Hydrogen	average (mg/kg)	91.43	109.8	-	152	122.56	104.38	93.36	75.198	142.173	116.498	123.574
CO ₂	average (ppmv)	75.79	82.6	-	196.24	-	66.83	-	36.73	59.31	61.33	96.8
moisture	average (%)	8.39	5.49	-	4.45	-	6.05	-	5.25	4.54	5	5.57
pH	average	7.11	7.23	-	7.05	-	6.92	-	6.54	7.31	6.85	7.3

J = below the detection limit (the substance in question was detected, but at levels below that which can be accurately characterized by the test method)

Test 5: 7% moisture, 114mg/kg H2

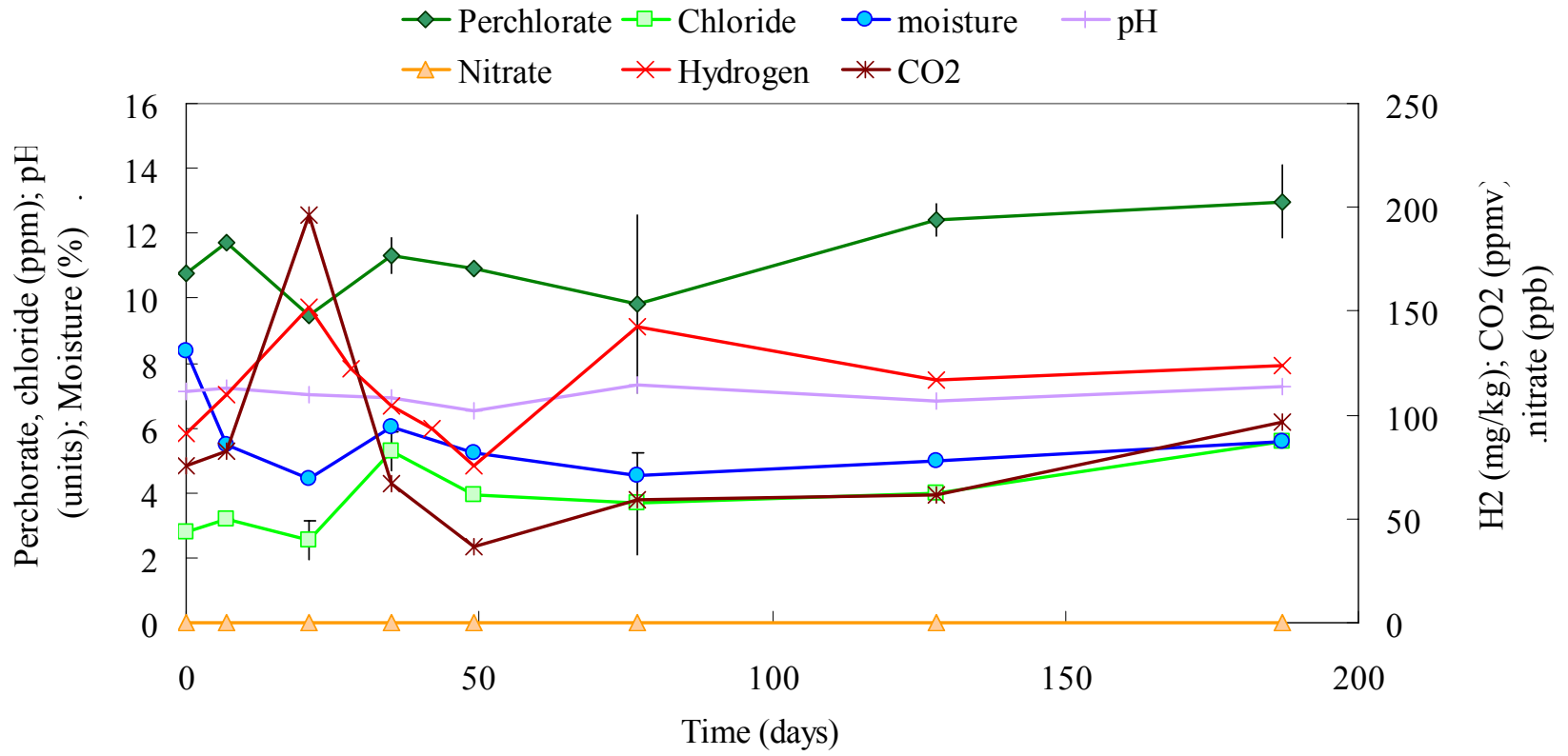

A.2.6 Test 6: 7% Moisture, 501 mg/kg ethyl acetate

		Time (days)										
		0	7	14	21	28	35	42	49	77	125	184
Perchlorate	average (ppm)	9.8	10.35	-	9.04	-	10.87	-	11.48	10.18	12.11	11.1
	std. dev.	0.28	0.75	-	2.07	-	2.38	-	0.02	1.35	0.68	0.58
Chloride	average (ppm)	2.68	3.16	-	4.18	-	3.92	-	4.95	3.21	4.7	4.62
	std. dev.	0.37	0.66	-	0.72	-	0.85	-	0.47	1.1	0.19	0.12
Nitrate	average (ppb)	J	J	-	J	-	J	-	J	J	J	J
	std. dev.	-	-	-	-	-	-	-	-	-	-	0
Ethyl Acetate	average (mg/kg)	373.7	289.14	3.83	101.12	2.48	73.22	63.87	21.3	11.7	0	0
	std. dev.	110.1	75.95	0.26	7.65	1.29	50.65	40.6	9.34	11.9	0	0
CO ₂	average (ppmv)	0	0	-	0	-	0	-	0	0	0	0
	std. dev.	0	0	-	0	-	0	-	0	0	0	0
moisture	average (%)	5.86	6.45	-	4.96	-	6.13	-	6.48	6.65	6.71	6.39
	std. dev.	0.23	0.61	-	0.06	-	0.08	-	0.17	0.04	0.62	0.24
pH	average	6.84	6.39	-	6.4	-	6.08	-	6.24	6.32	7.07	6.18
	std. dev.	0.01	0.06	-	0.07	-	0.1	-	0.014	0.05	0.06	0.23

J = below the detection limit (the substance in question was detected, but at levels below that which can be accurately characterized by the test method)

Test 6: 7% moisture, 501mg/kg Ethyl Acetate

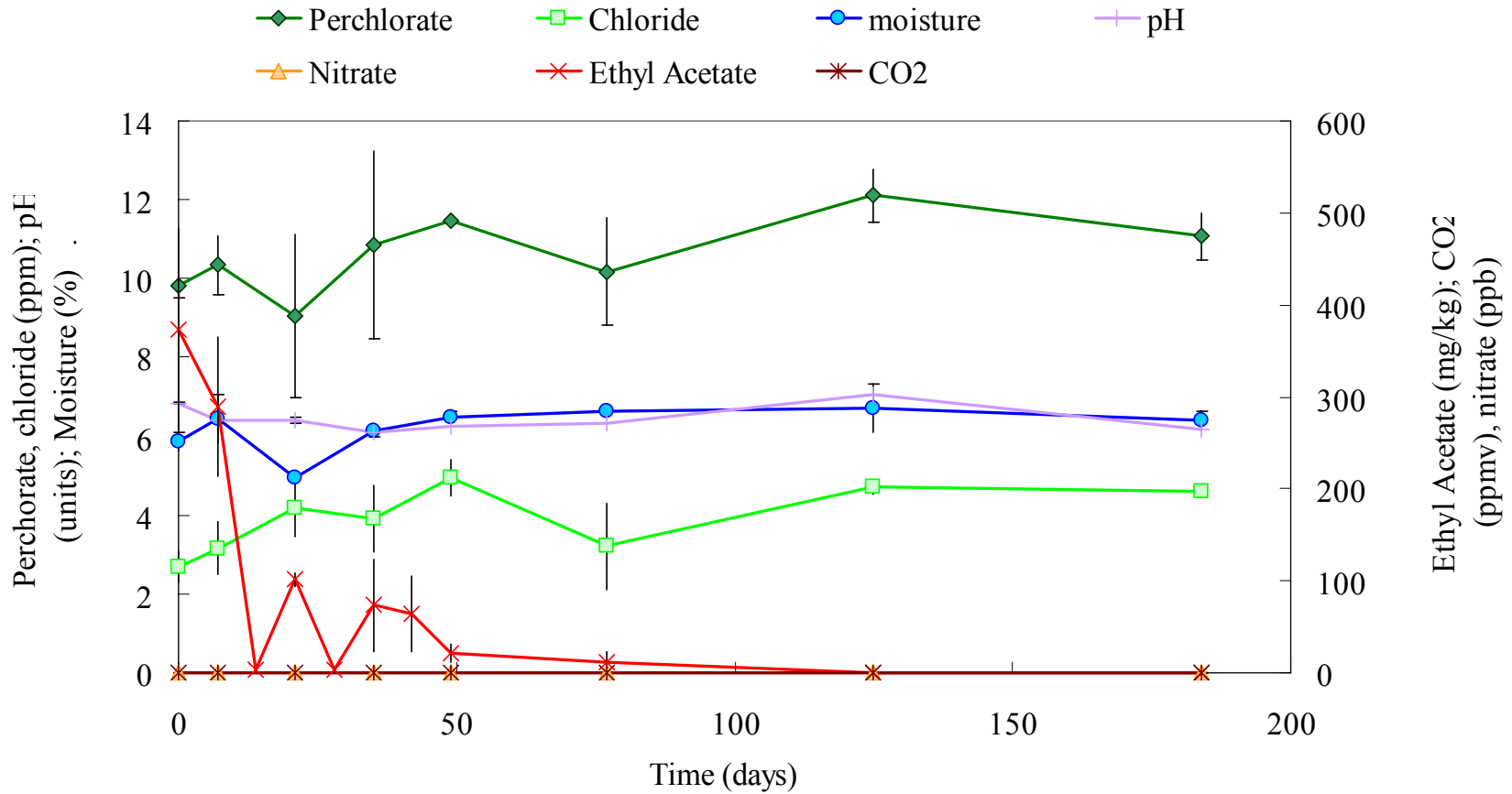

A.2.7 Test 7: 7% Moisture, 265 mg/kg 1-hexene

		Time (days)										
		0	7	14	21	28	35	42	49	77	125	185
Perchlorate	average (ppm)	9.55	10.57	-	9.96	-	11.07	-	11.14	10.68	13.09	10.62
	std. dev.	0.39	0.28	-	0.15	-	0.34	-	0.17	0.65	0.42	0.68
Chloride	average (ppm)	2.28	3.12	-	5.16	-	4.92	-	4.76	3.93	6.17	5.52
	std. dev.	0.07	0.49	-	0.045	-	0.31	-	0.82	0.68	1.2	0.67
Nitrate	average (ppb)	J	J	-	J	-	J	-	J	J	J	0
	std. dev.	-	-	-	-	-	-	-	-	-	-	0
1-Hexene	average (mg/kg)	43.8	209.426	311.334	253.403	102.724	74.896	213.139	85.59	221.272	131.273	129.52
	std. dev.	4.5	-	-	-	--	-	-	-	-	-	-
CO ₂	average (ppmv)	0	0	-	0	-	0	-	0	0	0	0
	std. dev.	0	0	-	0	-	0	-	0	0	0	0
moisture	average (%)	6.51	6.37	-	6.81	-	6.31	-	6.47	6.9	7.21	6.52
	std. dev.	0.21	0.32	-	0.17	-	0.8	-	0.1	0.73	0.02	0.44
pH	average	7.08	6.65	-	7.15	-	7.125	-	7.325	7.185	6.965	7.31
	std. dev.	0.13	0	-	0.01	-	0.035	-	0.06	0.02	0.01	0.01

J = below the detection limit (the substance in question was detected, but at levels below that which can be accurately characterized by the test method)

Test 7: 7% moisture, 265mg/kg 1-Hexene

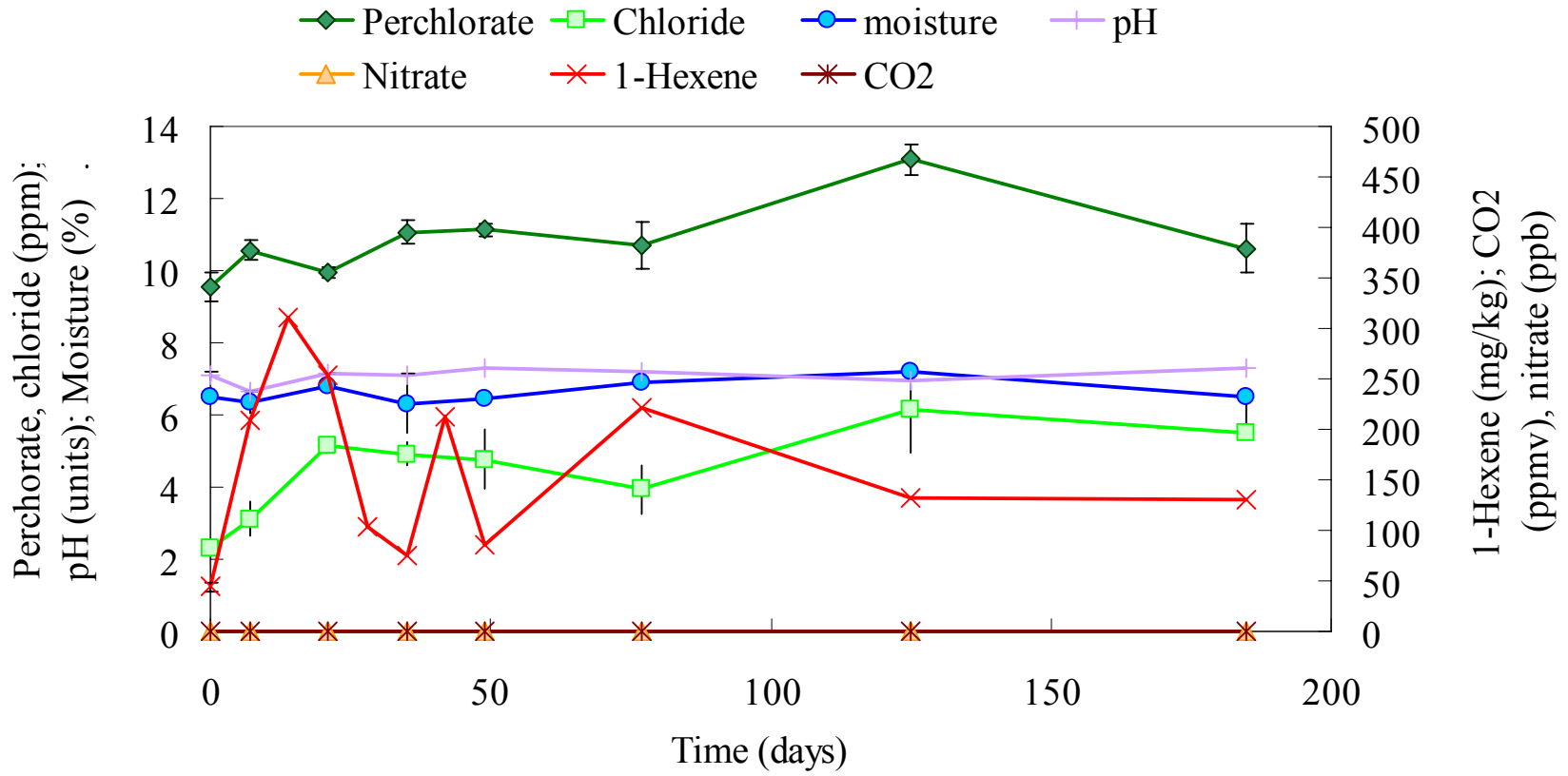

A.2.8 Test 8: 7% Moisture, 250 mg/kg LPG

		Time (days)										
		0	7	14	21	28	35	42	49	77	124	184
Perchlorate	average (ppm)	9.38	10.85	-	10.73	-	10.83	-	11.38	10.66	11.98	10.34
	std. dev.	0.17	0.11	-	0.19	-	0.22	-	0	1.28	0.04	2.25
Chloride	average (ppm)	1.27	2.71	-	5.16	-	4.89	-	4.03	2.98	5.03	4.76
	std. dev.	0.02	0.06	-	0.05	-	0.2	-	0	0.5	0.32	1.26
Nitrate	average (ppb)	J	J	-	J	-	J	-	J	J	J	0
	std. dev.	-	-	-	-	-	-	-	-	-	-	0
LPG	average (mg/kg)	198.05	628.76	705.87	798.79	638.8	506.9	248.261	600.656	826.349	914.157	680.5
CO ₂	average (ppmv)	0	0	-	0	-	0	-	0	0	0	0
moisture	average (%)	7.48	6.51	-	6.46	-	6.44	-	6.56	6.05	7.03	7.01
pH	average	6.77	7.27	-	7.18	-	6.89	-	6.91	7.22	6.98	7.25

J = below the detection limit (the substance in question was detected, but at levels below that which can be accurately characterized by the test method)

Test 8: 7% moisture, 250mg/kg LPG

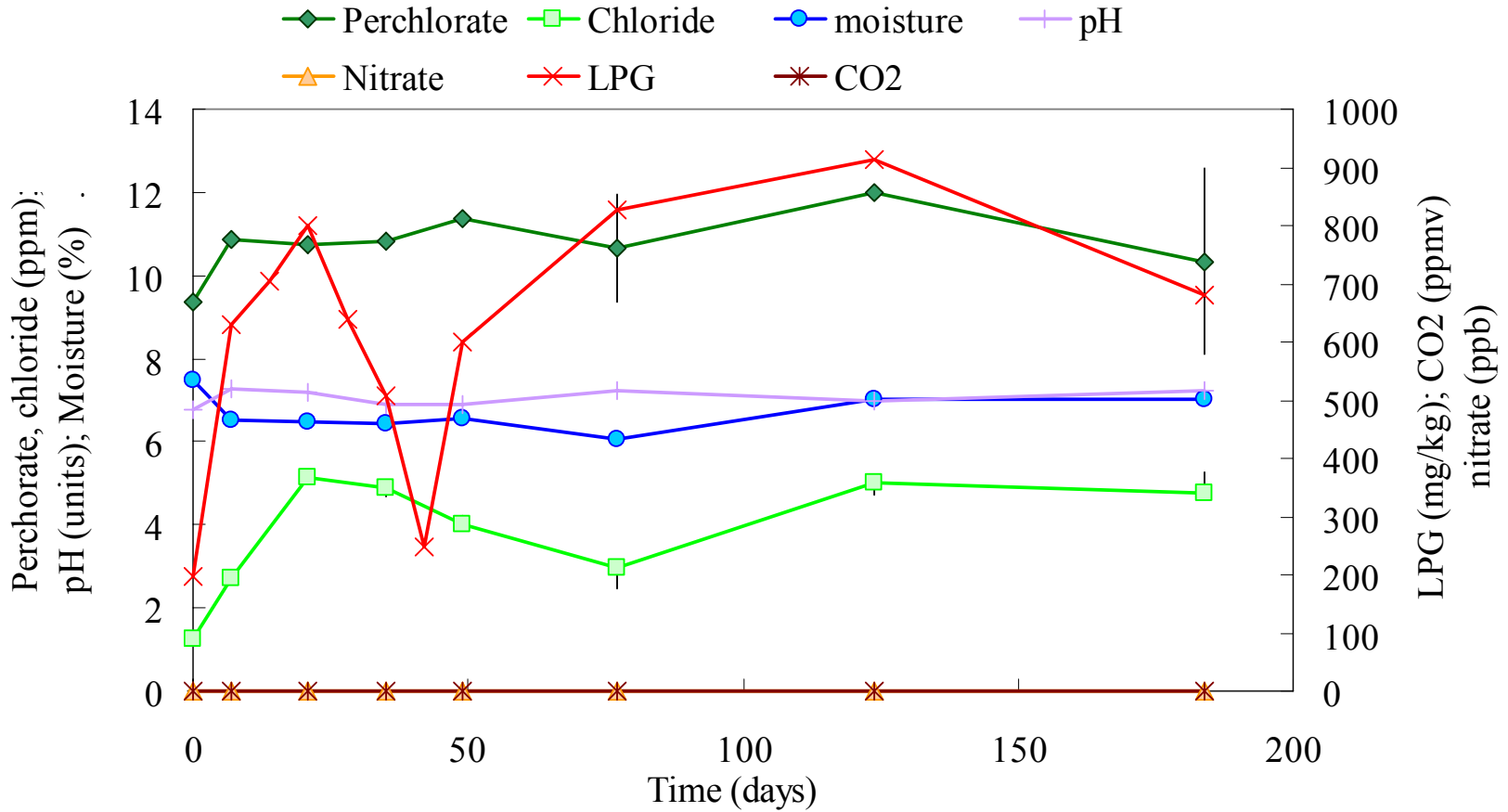

A.2.9 Test 9: 16% Moisture, 34 mg/kg H₂

		Time (days)										
		0	7	14	21	28	35	42	49	77	128	187
Perchlorate	average (ppm)	8.34	7.91	-	0.58	-	0.39	0	0	0	1.33	0
	std. dev.	0.04	0.05	-	0.02	-	0.54	0	0	0	0.49	0
Chloride	average (ppm)	1.8	3.57	-	6.77	-	13.26	4.75	5.35	4.65	6.3	7.27
	std. dev.	0.08	0.61	-	0.1	-	2.07	0.26	0.2	1.77	0.8	0.31
Nitrate	average (ppb)	J	J	-	J	-	J	J	J	J	J	0
	std. dev.	-	-	-	-	-	-	-	-	-	-	0
Hydrogen	average (mg/kg)	29.67	36.88	35.35	70.1	122.56	37.795	76.115	62.626	75.689	75.463	56.981
CO ₂	average (ppmv)	25.14	22.03	-	20.92	-	19.61	36.75	0	5.22	60.5	0
moisture	average (%)	14.84	14.66	-	15.71	-	15.32	15.65	15.06	15.56	15.17	15.21
pH	average	7.28	7.14	-	6.5	-	7.01	6.32	6.71	7.36	7.01	7.15

J = below the detection limit (the substance in question was detected, but at levels below that which can be accurately characterized by the test method)

Test 9: 16% moisture, 34mg/kg H2

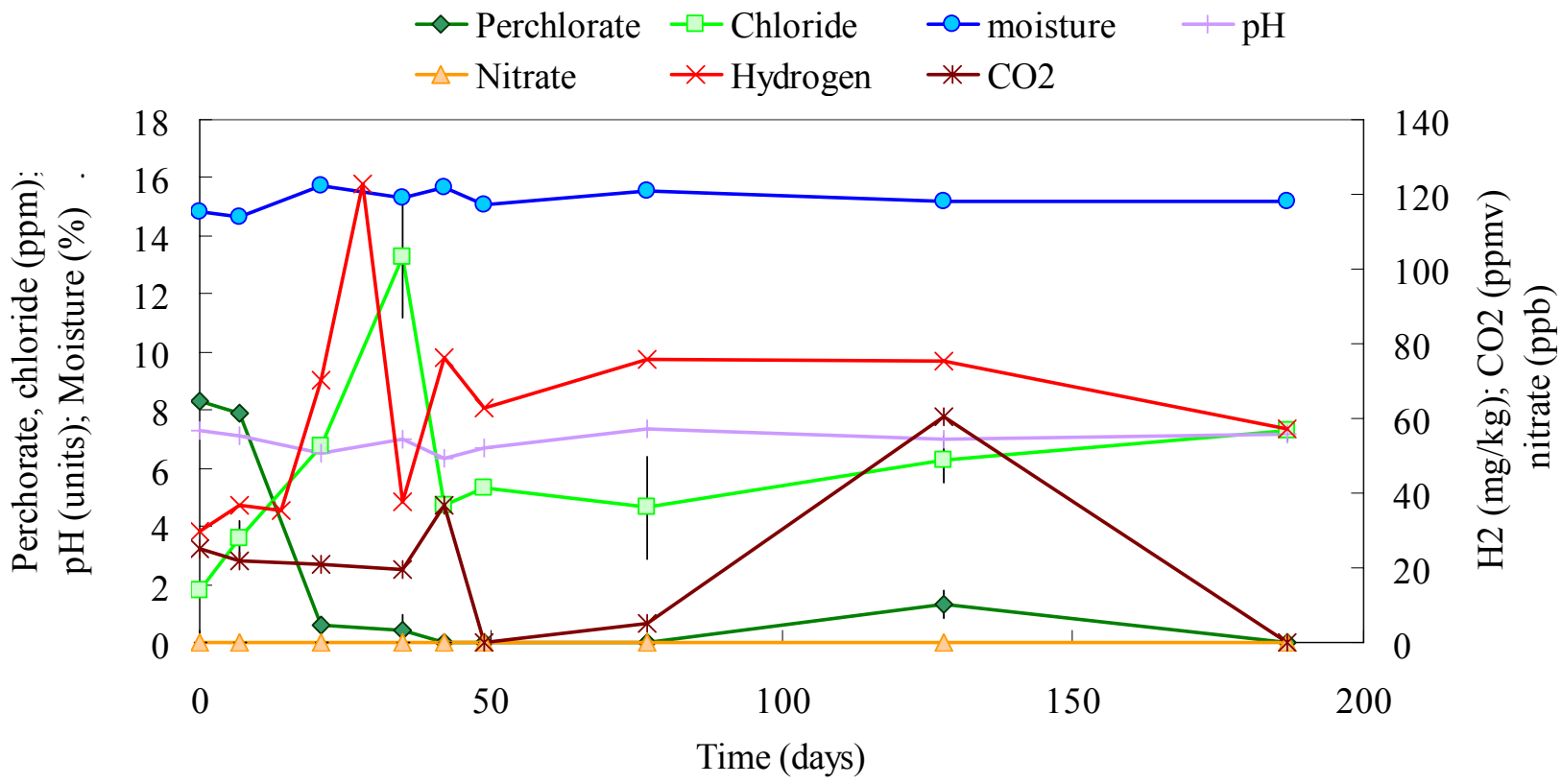

A.2.10 Test 10: 16% Moisture, 150 mg/kg ethyl acetate

		Time (days)										
		0	7	14	21	28	35	42	49	77	125	184
Perchlorate	average (ppm)	7.96	9.12	-	9.47	-	7.75	-	9.64	8.71	8.28	8.53
	std. dev.	0.36	0.002	-	0.1	-	0.34	-	0	1.44	0.63	0
Chloride	average (ppm)	1.41	2.46	-	5.53	-	4.67	-	3.64	3.46	3.85	2.93
	std. dev.	0.08	0.01	-	0.04	-	0.31	-	0	1.33	0.27	0
Nitrate	average (ppb)	J	J	-	J	-	J	-	J	J	J	0
	std. dev.	-	-	-	-	-	-	-	-	-	-	0
Ethyl Acetate	average (mg/kg)	85	34.5	0.07	3.672	0.73	0.142	0	0	0	0	0
CO ₂	average (ppmv)	0	0	-	0	-	0	-	0	0	0	0
moisture	average (%)	14.05	15.46	-	15.54	-	14.94	-	14.76	14.7	15.59	15
pH	average	6.9	6.9	-	7	-	6.64	-	6.81	6.99	7.05	6.82

J = below the detection limit (the substance in question was detected, but at levels below that which can be accurately characterized by the test method)

Test 10: 16% moisture, 150mg/kg Ethyl Acetate

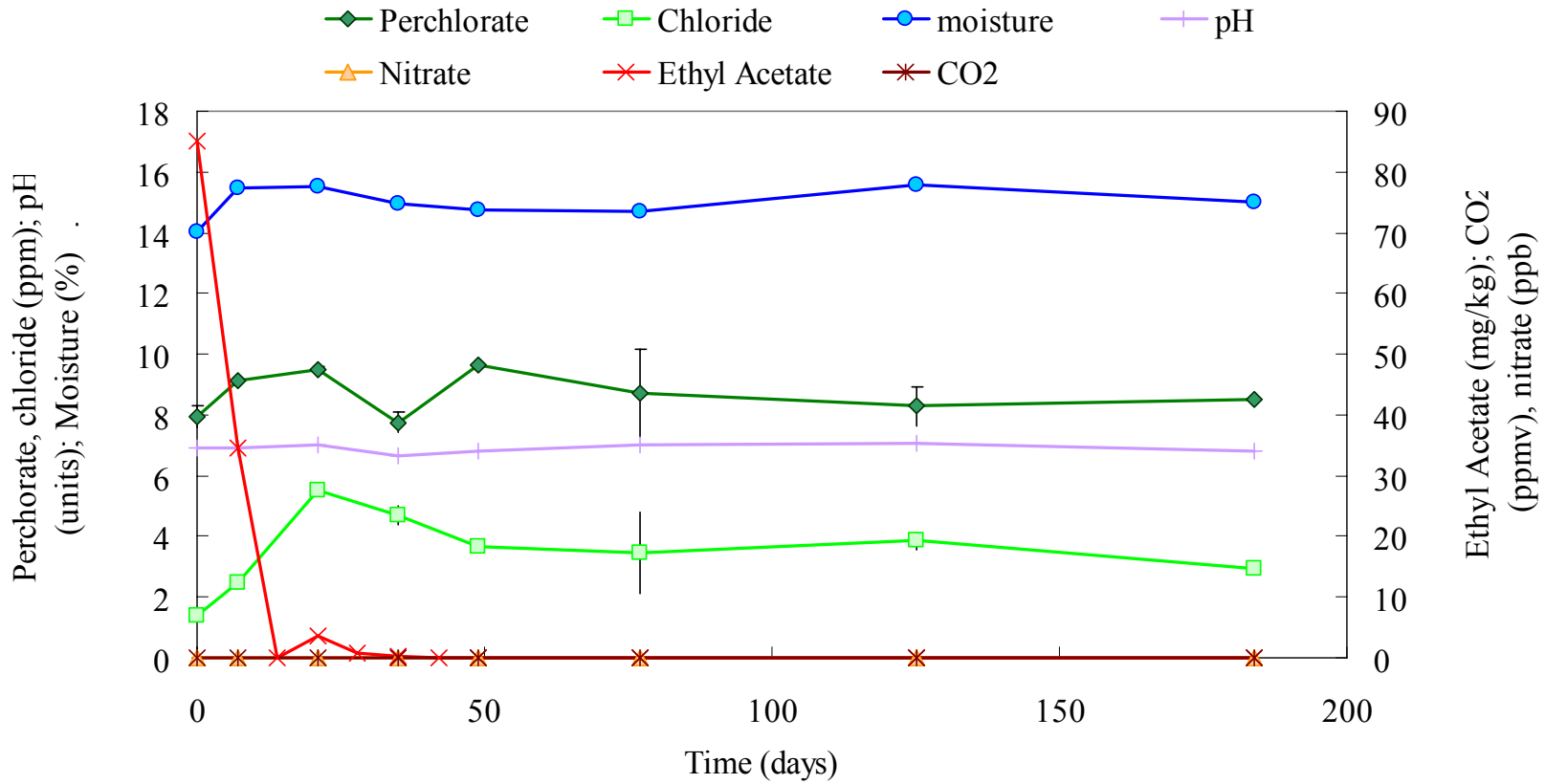

A.2.11 Test 11: 16% Moisture, 80 mg/kg 1-hexene

		Time (days)									
		0	7	14	21	28	35	42	49	77	125
Perchlorate	average (ppm)	8.44	8.76	-	6.7	8.23	7.72	8.02	8.91	2.54	5
	std. dev.	0.28	0.23	-	0.79	0.77	0.9	0.62	0.65	2.94	3.68
Chloride	average (ppm)	0.66	2.59	-	2.38	7.87	4.55	3.65	3.74	4.14	6.21
	std. dev.	0.74	0.43	-	0.38	4.83	0.42	0.78	0.53	0.68	1.11
Nitrate	average (ppb)	J	J	-	J	J	J	J	J	J	J
	std. dev.	-	-	-	-	-	-	-	-	-	-
1-Hexene	average (mg/kg)	27.4	74.89	70.99	90.9	59.96	73.87	83.11	51.536	24.262	68.065
	std. dev.	6.42	1.36	3.3	5.89	25.8	4.88	15.61	28.79	6.2	8
CO ₂	average (ppmv)	0	0	-	0	0	0	0	0	0	0
	std. dev.	0	0	-	0	0	0	0	0	0	0
moisture	average (%)	14.32	14.48	-	14.9	15.05	15.02	15.05	14.96	14.65	14.72
	std. dev.	1.38	0.34	-	0.38	0.95	0.36	0.6	0.3	0.69	0.18
pH	average	7.08	6.91	-	7.26	7.28	7.34	7.16	7.415	7.27	6.97
	std. dev.	0.01	0.08	-	0.09	0.04	0.11	0.04	0.12	0.04	0

J = below the detection limit (the substance in question was detected, but at levels below that which can be accurately characterized by the test method)

Test 11: 16% moisture, 80mg/kg 1-Hexene

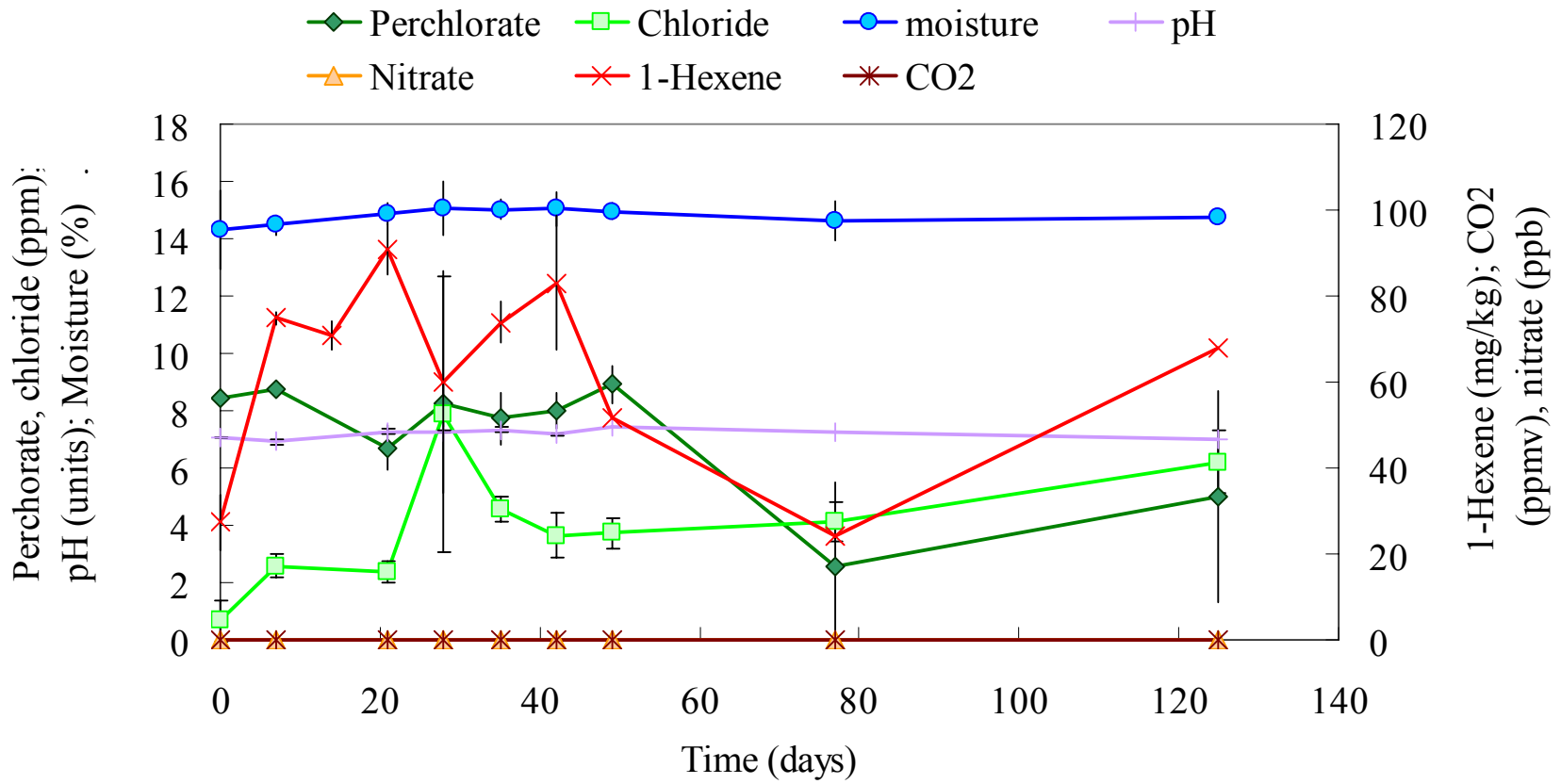

A.2.12 Test 12: 16% Moisture, 75 mg/kg LPG

		Time (days)										
		0	7	14	21	28	35	42	49	77	124	184
Perchlorate	average (ppm)	8.45	9.1	-	10	-	8.84	-	10.87	3.9	4.25	2.71
	std. dev.	0.42	0.4	-	0.99	-	0.57	-	0.32	4.53	2.92	0.35
Chloride	average (ppm)	1.56	2.52	-	3.94	-	3.97	-	3.81	4.64	6.14	6.85
	std. dev.	0.79	0.25	-	0.52	-	0.34	-	0.13	1.28	1.18	1.69
Nitrate	average (ppb)	J	J	-	J	-	J	-	J	J	J	J
	std. dev.	-	-	-	-	-	-	-	-	-	-	-
LPG	average (mg/kg)	63.53	201.05	272.06	170.12	261.36	235.2	347.99	292.187	377.18	374.665	301.312
	std. dev.	7.26	75.67	14.98	26.66	27.9	5.53	24.7	5.2	34.92	5.97	0
CO ₂	average (ppmv)	0	0	-	0	-	-	-	0	0	0	0
	std. dev.	0	0	-	0	-	-	-	0	0	0	0
moisture	average (%)	13.83	15.07	-	13.31	-	14.36	-	14.28	13.62	14.46	12.87
	std. dev.	0.44	0.92	-	0.15	-	0.24	-	1.89	0.81	1.2	0
pH	average	6.96	7	-	7.13	-	6.62	-	7.11	7.2	6.96	7.84
	std. dev.	0.07	0.06	-	0.03	-	0.33	-	0.11	0.02	0	0

J = below the detection limit (the substance in question was detected, but at levels below that which can be accurately characterized by the test method)

Test 12: 16% moisture, 75mg/kg LPG

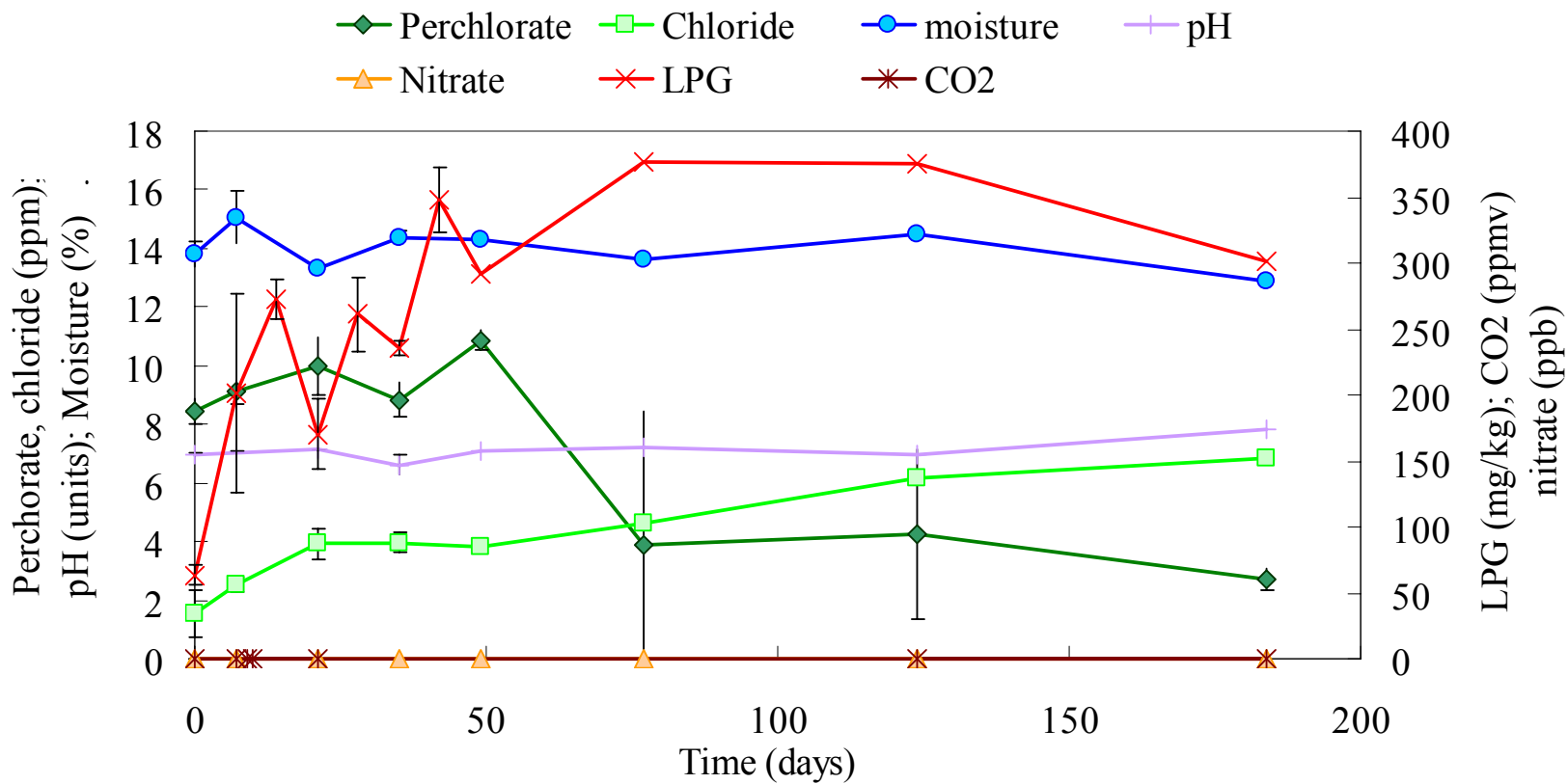

A.2.13 Test 13: 16% Moisture, 114 mg/kg H₂

		Time (days)										
		0	7	14	21	28	35	42	49	77	128	187
Perchlorate	average (ppm)	5.93	8.05	-	0.49	-	0	0.25	0.59	0	0.466	0
	std. dev.	3.99	0.23	-	0.05	-	0	0.43	0.69	0	0.024	0
Chloride	average (ppm)	2.16	3.42	-	4.76	-	8.26	6.22	4.87	5.52	6.73	8.12
	std. dev.	0.61	0.45	-	0.12	-	2.88	0.36	3.44	1.65	0.59	1.96
Nitrate	average (ppb)	J	J	-	J	-	J	J	J	J	J	J
	std. dev.	-	-	-	-	-	-	-	-	-	-	-
Hydrogen	average (mg/kg)	111.77	112.7	118.12	159.82	128.91	97.22	126.455	126.96	112.945	72.85	83.326
	std. dev.	32.6	1.6	3.07	1.14	2.37	1.7	26.02	21.87	32.67	9.02	5.153
CO ₂	average (ppmv)	77.67	73.88	-	210.15	-	57.35	82.48	19.98	63.52	62.38	68.14
	std. dev.	2.27	0.61	-	0.78	-	2.36	18.45	20.38	67.18	3.01	0.43
moisture	average (%)	14.11	14.28	-	14.76	-	14.86	14.71	15.42	14.45	15.42	15.31
	std. dev.	0.02	0.13	-	0.3	-	0.55	0.02	0.44	0.86	1.06	1.23
pH	average	7.33	7.31	-	6.79	-	6.95	6.6	6.68	7.04	7.045	6.38
	std. dev.	0.07	0.05	-	0.04	-	0.04	0.08	0.06	0.56	0.08	0.1

J = below the detection limit (the substance in question was detected, but at levels below that which can be accurately characterized by the test method)

Test 13: 16% moisture, 114mg/kg H2

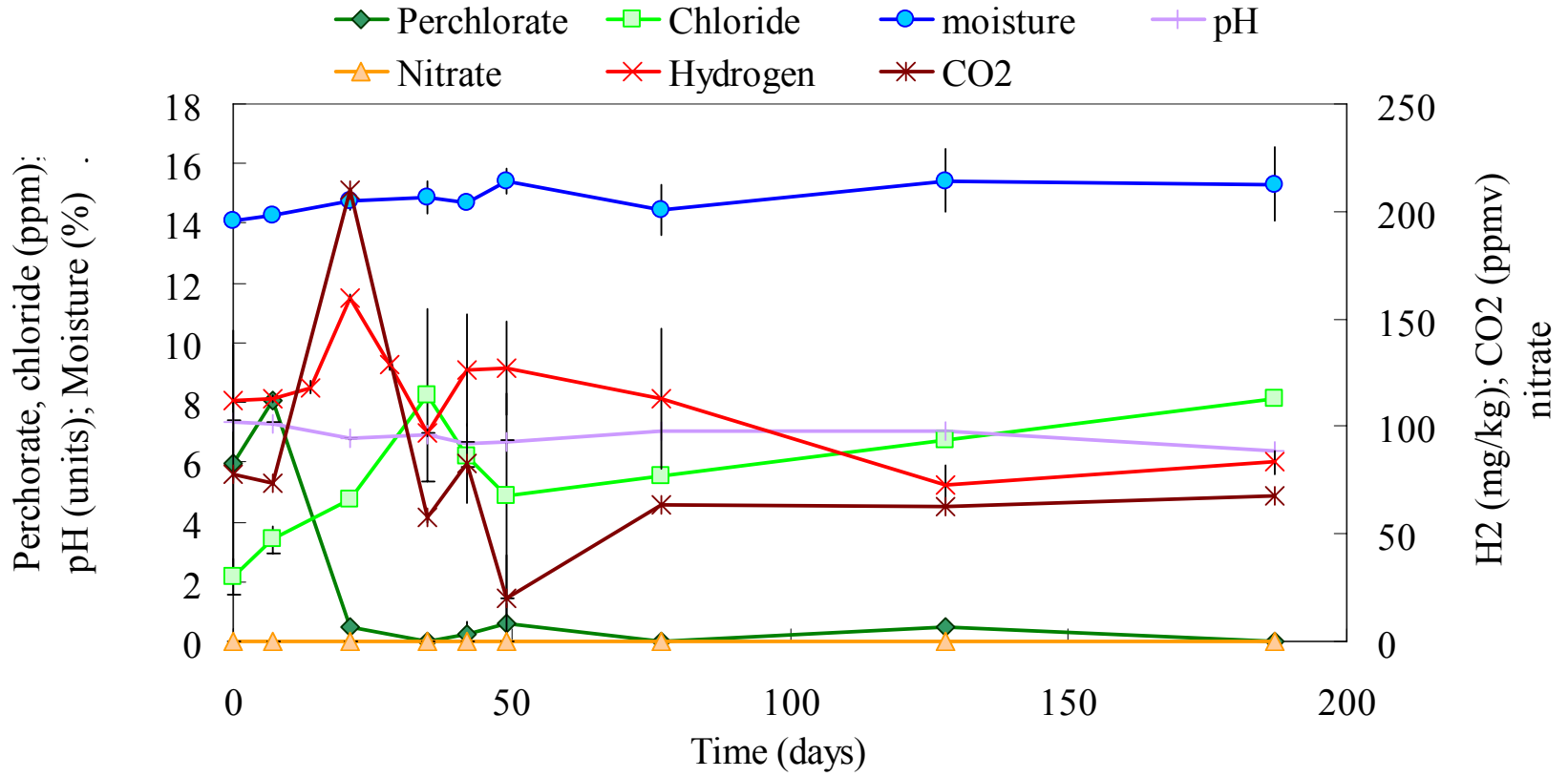

A.2.14 Test 14: 16% Moisture, 501 mg/kg ethyl acetate

		Time (days)										
		0	7	14	21	28	35	42	49	77	125	184
Perchlorate	average (ppm)	9.04	8.97	-	9.52	-	9.42	-	10.15	9.29	9.67	9.52
	std. dev.	0.16	0.04	-	0.13	-	0.51	-	0	1.49	0.44	0
Chloride	average (ppm)	2.14	2.16	-	5.11	-	3.59	-	3.48	2.62	3.42	3.36
	std. dev.	0.09	0.05	-	0.19	-	0.18	-	0	0.98	0.42	0
Nitrate	average (ppb)	J	J	-	J	-	J	-	J	J	J	0
	std. dev.	-	-	-	-	-	83	-	-	-	-	0
Ethyl Acetate	average (mg/kg)	296.38	282.763	3.75	113.974	1.92	25.84	31.99	4.913	1.015	0	0
CO ₂	average (ppmv)	0	0	-	0	-	0	-	0	0	0	0
moisture	average (%)	12.99	15.74	-	14.75	-	14.74	-	15.64	15.59	15.97	15.4
pH	average	6.75	6.56	-	6.55	-	6.25	-	6.3	6.45	6.99	6.58

J = below the detection limit (the substance in question was detected, but at levels below that which can be accurately characterized by the test method)

Test 14: 16% moisture, 501mg/kg Ethyl Acetate

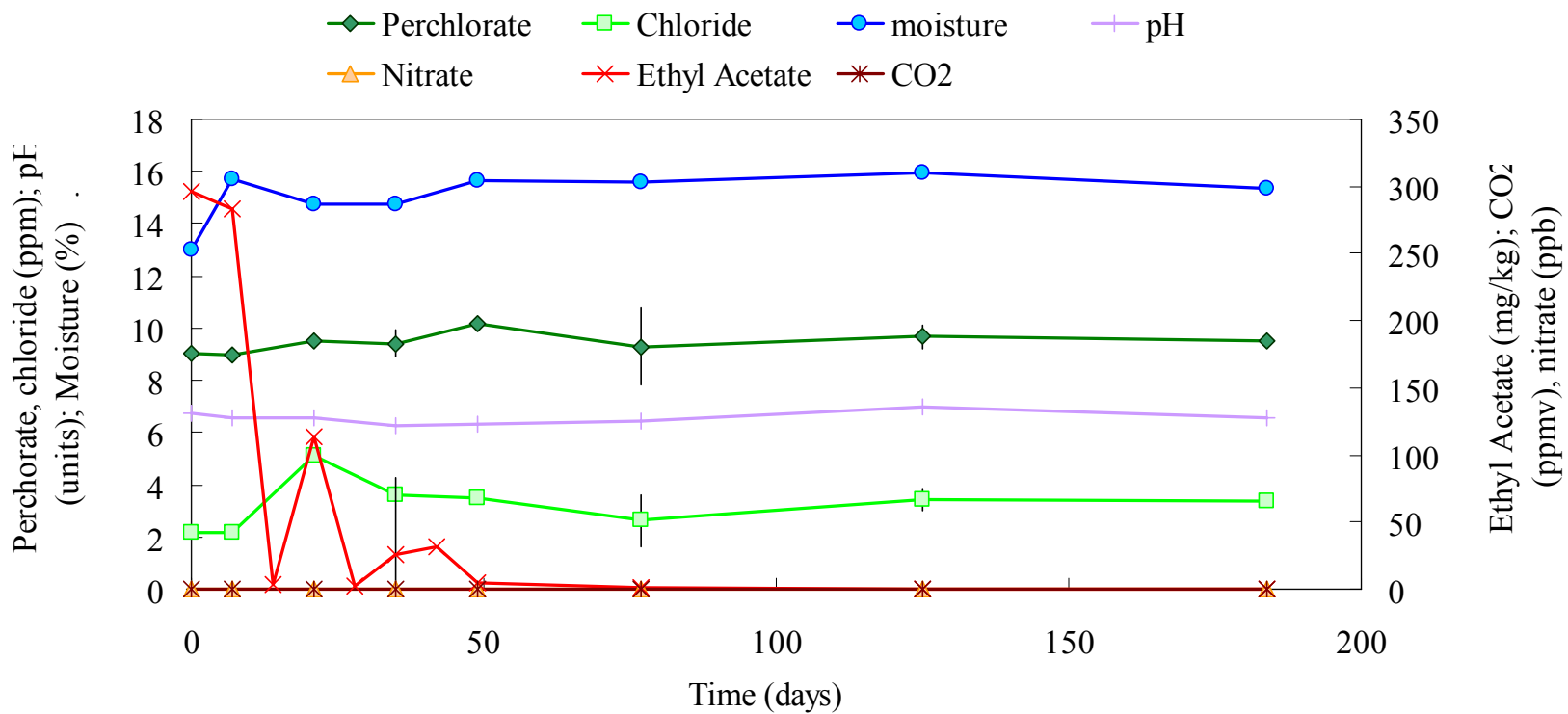

A.2.15 Test 15: 16% Moisture, 265 mg/kg 1-hexene

		Time (days)									
		0	7	14	21	28	35	42	49	77	125
Perchlorate	average (ppm)	8.51	9.11	-	7.91	8.3	7.85	7.67	2.32	1.75	1.96
	std. dev.	0.01	0.05	-	0.01	0.4	0.56	0.22	0	0.016	0.54
Chloride	average (ppm)	2.05	2.68	-	1.97	4.05	4.36	2.69	6.75	4.48	4.26
	std. dev.	0.04	0.03	-	0.06	0.01	0.46	0.14	0	0.4	0.34
Nitrate	average (ppb)	J	J	-	J	J	J	J	J	J	J
	std. dev.	-	-	-	-	-	-	-	-	-	-
1-Hexene	average (mg/kg)	48.215	211.11	103.13	191.27	67.84	108.556	212.885	40.65	356.845	120.96
CO ₂	average (ppmv)	0	0	-	0	0	0	0	0	0	0
moisture	average (%)	16.51	-	-	12.76	14.23	13.78	13.83	13.83	15.58	15.57
pH	average	7.22	6.88	-	7.18	7.08	7.22	7.3	7.33	7.24	6.97

J = below the detection limit (the substance in question was detected, but at levels below that which can be accurately characterized by the test method)

Test 15: 16% moisture, 265mg/kg 1-Hexene

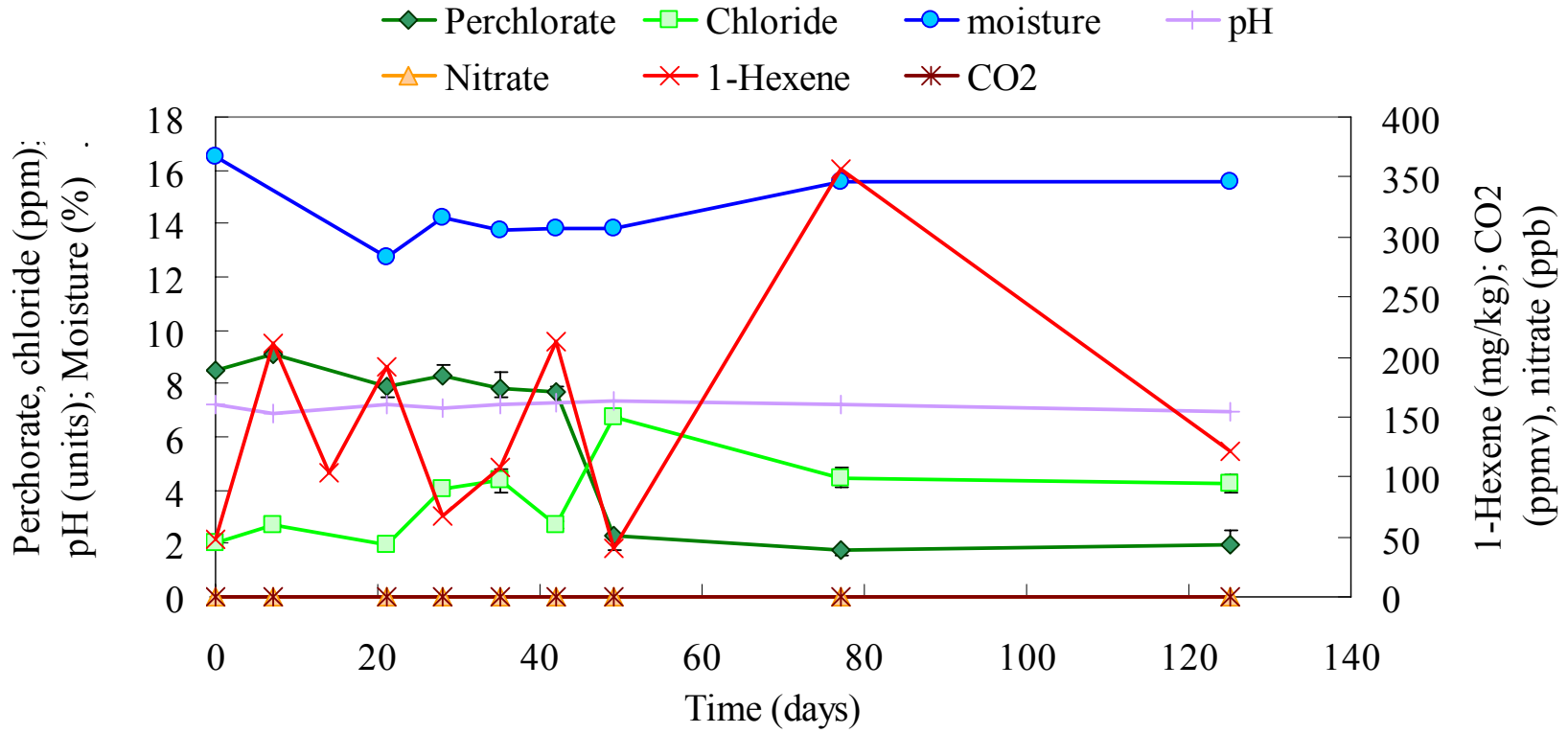

A.2.16 Test 16: 16% moisture, 250 mg/kg LPG

		Time (days)										
		0	7	14	21	28	35	42	49	77	124	184
Perchlorate	average (ppm)	8.51	8.67	-	10.08	-	8.06	-	5.77	3.83	1.1	0
	std. dev.	0.57	0.31	-	0.52	-	4.32	-	2	2.33	0.13	0
Chloride	average (ppm)	1.04	2.19	-	4.36	-	4.66	-	5.09	4.3	5.26	6.03
	std. dev.	0.18	0.28	-	0.12	-	0.69	-	0.51	0.72	0.81	0.83
Nitrate	average (ppb)	J	J	-	J	-	J	-	J	J	J	0
	std. dev.	-	-	-	-	-	-	-	-	-	-	0
LPG	average (mg/kg)	214.2	590.55	693.16	498.5	733.52	509.3	901.34	615.87	1022.21	830.391	589.22
	std. dev.	0.25	46.56	52.29	0.07	176.48	69.4	180.8	21.3	82.93	158.8828	2.76
CO ₂	average (ppmv)	0	0	-	0	-	0	-	0	0	0	27.5
	std. dev.	0	0	-	0	-	0	-	0	0	0	38.89
moisture	average (%)	15.84	15.31	-	14.2	-	13.64	-	14.47	14.38	14.78	13.85
	std. dev.	1.29	1.54	-	0.85	-	0.68	-	0.37	0.07	0.15	0.05
pH	average	7.04	7.23	-	7.28	-	6.96	-	7.3	7.245	6.975	7.56
	std. dev.	0.99	0.02	-	0.04	-	0.1	-	0.13	0.007	0.01	0.08

J = below the detection limit (the substance in question was detected, but at levels below that which can be accurately characterized by the test method)

Test 16: 16% moisture, 250mg/kg LPG

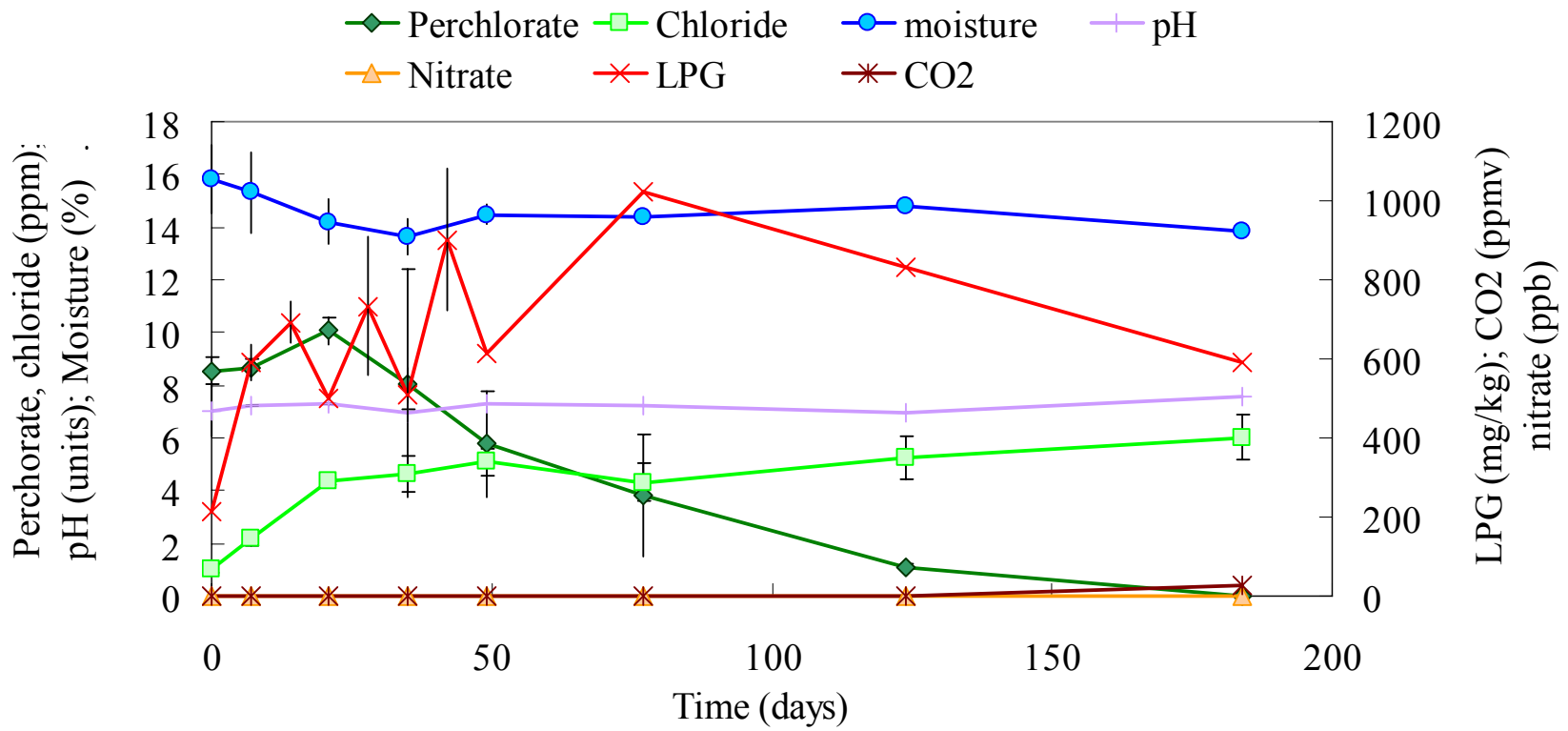

A.2.17 Test 17: Negative control. 16% Moisture, no external electron donor.

		Time (days)										
		0	7	14	21	28	35	42	49	77	124	183
Perchlorate	average (ppm)	8.59	9.47	-	8.87	-	2.12	-	2.47	0.85	1.26	0
	std. dev.	0.35	0.03	-	0.08	-	1.91	-	0	0.086	0.13	0
Chloride	average (ppm)	1.16	4.12	-	4.34	-	6.28	-	1.3	5.09	7.7	5.5
	std. dev.	0.09	0.004	-	0.04	-	0.02	-	0	0.44	0.88	0.23
Nitrate	average (ppb)	J	J	-	J	-	J	-	J	J	J	0
	std. dev.	-	-	-	-	-	-	-	-	-	-	0
Electron Donor	average (mg/kg)	0	0	0	0	0	0	0	0	0	0	0
CO ₂	average (ppmv)	0	0	-	0	-	0	-	0	0	0	0
moisture	average (%)	15.41	15.67	-	14.36	-	14.87	-	15.7	14.36	16.25	14.95
pH	average	7.07	7.09	-	7.3	-	7.05	-	6.97	7.23	7.13	7.58

J = below the detection limit (the substance in question was detected, but at levels below that which can be accurately characterized by the test method)

Test 17: Negative control. 16% moisture, no electron donor.

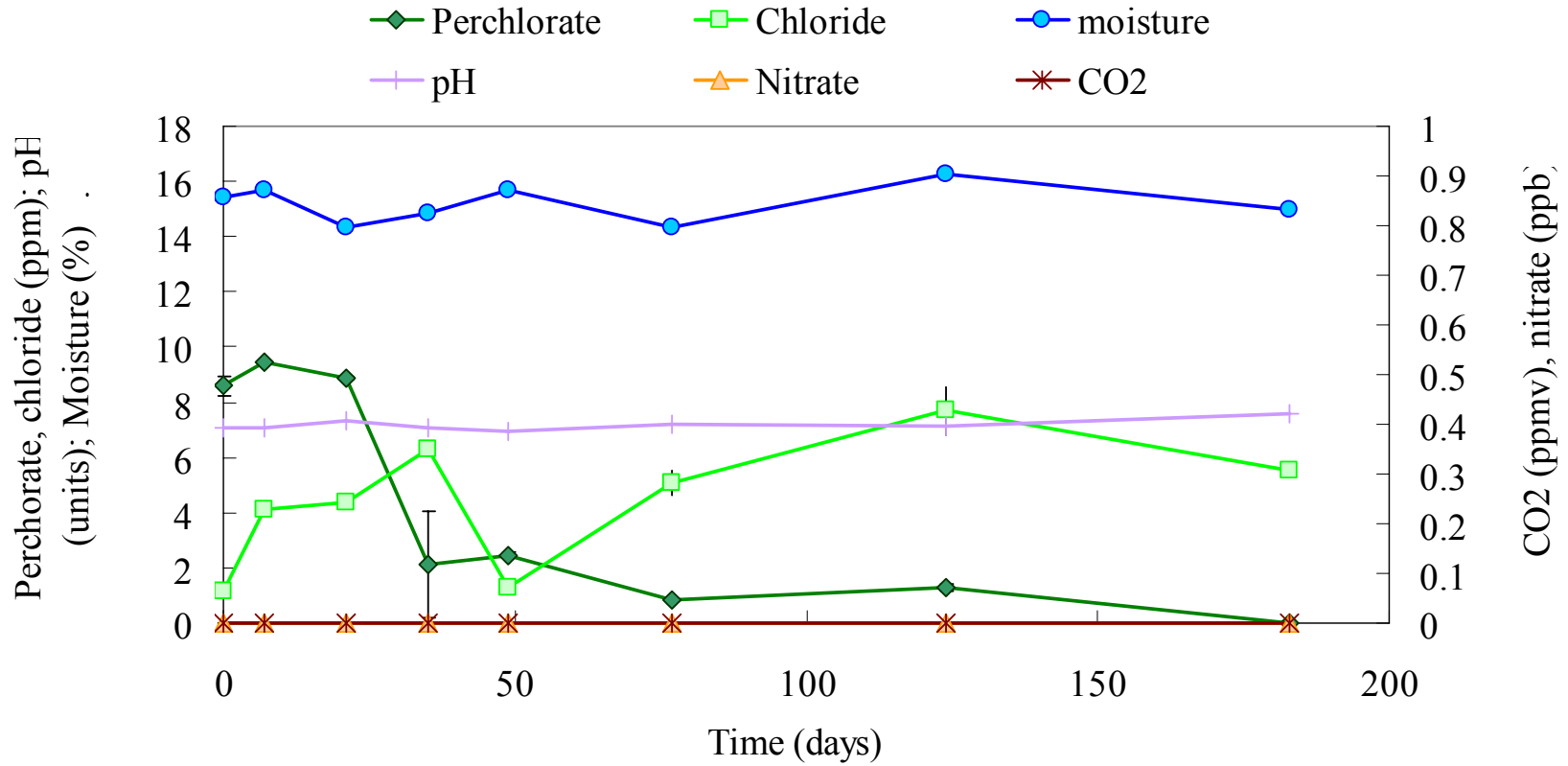

A.2.18 Positive control. 16% Moisture, 436 mg/kg ethanol.

		Time (days)										
		0	7	14	21	28	35	42	49	77	124	183
Perchlorate	average (ppm)	8.49	9.2	-	8.5	-	6.29	-	10.04	0	1.17	0
	std. dev.	0.08	0.04	-	0.27	-	0.11	-	0	0	0.08	0
Chloride	average (ppm)	1.07	4.06	-	2.96	-	4.2	-	3.8	4.99	4.77	6.64
	std. dev.	0.03	0.03	-	3.53	-	0	-	0	0.31	0.97	0.68
Nitrate	average (ppb)	J	J	-	J	-	J	-	J	J	J	0
	std. dev.	-	-	-	-	-	-	-	-	-	-	0
Ethanol	average (mg/kg)	14.23	5.034	3.32	3.184	3.04	3.412	3.964	3.183	5.93	1.742	2.257
CO ₂	average (ppmv)	0	0	-	0	-	0	-	0	0	0	0
moisture	average (%)	14.63	15.34	-	14.65	-	14.69	-	15.14	15.67	14.27	15.8
pH	average	7.11	7.15	-	7.14	-	6.86	-	6.89	7.15	7.05	7.22

J = below the detection limit (the substance in question was detected, but at levels below that which can be accurately characterized by the test method)

Test 18: Positive control. 16% moisture, 436mg/kg Ethanol.

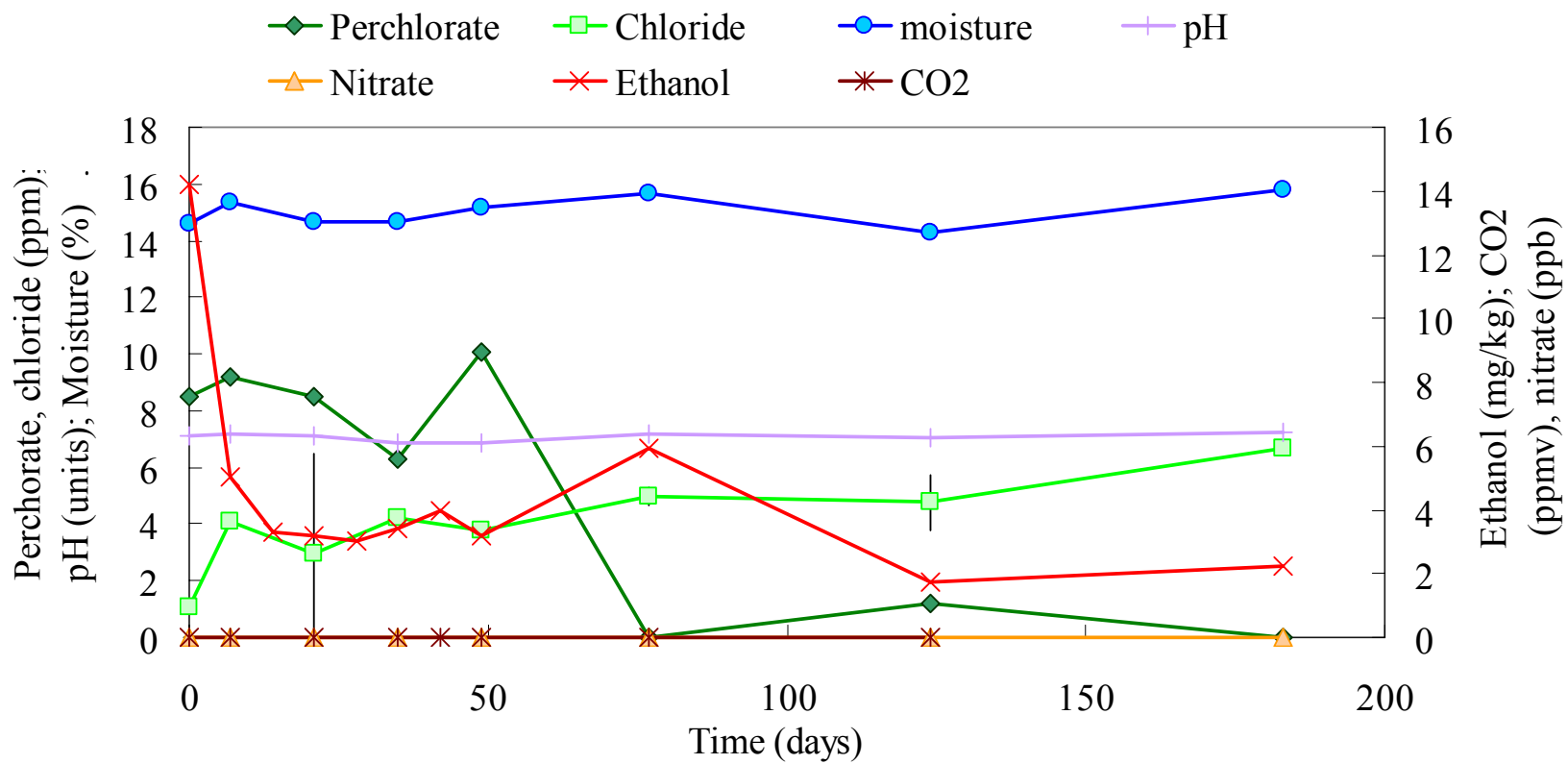

Appendix A-4
Column Test Data

B.1 H₂ Column Study Theoretical Breakthrough Calculations

Electron Donor: Hydrogen

Soil moisture: 10%

Bulk gas velocity: 0.01 cm/s

1. Measure the moisture content of the stored soil in duplicate. Add DDI water if necessary to raise the soil moisture to 10%.
2. Weigh out the mass of soil to be packed into the two duplicate columns to make the soil density in each column similar to the site conditions (1.6 g/mL, GEDIT_calc_Nov2005 spreadsheet).

Column Dimensions: $D = 2 \text{ in} = 2 \text{ in} \times 2.54 \text{ cm/in} = 5.08 \text{ cm}$

$H = 5 \text{ ft} = 5 \times 30.48 \text{ cm/ft} = 152.4 \text{ cm}$

$\text{Area} = \pi D^2/4 = \pi(5.08 \text{ cm})^2/4 = 20.27 \text{ cm}^2$

$V = \text{Area} \times H = 152.4 \text{ cm} \times 20.27 \text{ cm}^2 = 3089.15 \text{ cm}^3 = 3089.15 \text{ mL}$

So the mass of soil that needs to be packed into each column is:

Soil mass = 3089.15 mL \times 1.6 g/mL = 4942.64 g = **4.94 kg**

3. Pack the soil into two columns made of clear polyvinylchloride (PVC) pipe. Pack the columns by adding 1 – 2” lifts of soil and tapping the side of the column between lifts to promote even soil distribution within the column.
4. Purge both of the columns with nitrogen gas until less than 1% oxygen is detectable in the column effluent.
5. Inject 20% hydrogen and 80% nitrogen mixed gas at a bulk gas average linear velocity, $v_{\text{ave}} = 0.01 \text{ cm/s}$, assuming a soil porosity, $n = 40\%$.

Flow rate, $Q = (v_{\text{ave}} \times n) \times A$

$= (0.01 \text{ cm/s} \times 0.4) \times 20.27 \text{ cm}^2 = 0.081 \text{ cm}^3/\text{s} \times 60 \text{ s/min} = 4.86 \text{ cm}^3/\text{min} = 4.86$

mL/min

The mass flow controllers will be set to **4.9 mL/min**.

6. The effluent of the column will be tested for H₂ concentration **every 30 minutes** for the first 2 hours, and then after an increase in H₂ has been observed, samples will be taken approximately every 10 minutes to capture a breakthrough curve that contains a minimum of five points for each column.

Time to breakthrough, $t = H/v$

$= (152.4 \text{ cm}) / (0.01 \text{ cm/s}) \times (1 \text{ hour} / 3600 \text{ sec}) = \mathbf{4.23 \text{ hours}}$

7. After hydrogen has been observed to travel from the beginning to the end of the duplicate columns, gas injection will be stopped, and the column ends capped. Headspace samples for hydrogen will then be taken (at $t = 0$) with a 250 μL gas-tight syringe from seven sampling ports spaced evenly along the column length (i.e., out of the 28 total ports on the column, every third port will be sampled). The columns will then be incubated at room temperature in the dark for 2 – 4 weeks.

8. After 2 – 4 weeks, 200 uL headspace samples will again be withdrawn from every third sampling port of both columns to measure hydrogen and oxygen concentrations and test for “hydrogen floating”. If hydrogen levels have dropped below 2 mg/kg, the columns will be repurged with the 20% H₂ / 80% N₂ gas mixture as before, and then capped. The hydrogen concentrations along the length of the column will be remeasured prior to continued incubation.
9. After approximately 2 months of total incubation, the headspace will again be sampled for hydrogen and oxygen as before, and then one of the duplicate columns will be sacrificed and the soil behind **every other sampling port** (i.e., 14 out of the total 28 ports on the column) will be analyzed for perchlorate, chlorate, chlorite, chloride, nitrate, nitrite, pH, and soil moisture. If, at this time, perchlorate levels are below detection, then the second column will also be sacrificed and analyzed; if not, it will be allowed to incubate approximately one more month before being sacrificed and analyzed as described above.

Appendix

Electron donor sufficiency calculation:

Void fraction of soil = 40% (GEDIT_Evans_calc_Nov2005 spreadsheet)

Volume of H₂ in the column = 40% × V_{column} × 10% = 40% × 3089.15 mL × 10% = 123.57 mL

Mass of H₂ in the column = $1.013 \times 10^5 \text{ Pa} \times 123.57 \text{ mL} \times \frac{1 \text{ m}^3}{1000 \text{ mL}} = \mathbf{5.10 \text{ mol}}$
 $\frac{8.314472 [\text{m}^3 \cdot \text{Pa} \cdot \text{K}^{-1} \cdot \text{mol}^{-1}] \times 295 \text{ K}}$

Perchlorate concentration in the soil is about 10ppm.

Perchlorate mass in the column = 4.94 kg soil × 10 mg/kg = 49.4 mg / 99.45g/mol = 0.5 mmol

Degrade 1mol perchlorate needs 4 mol hydrogen,

So **H₂ mass needed to degrade all of the perchlorate in column** = 0.5 mmol × 4 = **2 mmol.**

Safety factor = 5.10 × 10³ mmol / 2 mmol = 2550

The hydrogen is sufficient!

B.2 Experimental Breakthrough Time Calculation

Using column #1 as an example, the breakthrough time was calculated as below:
 Inlet hydrogen concentration $C_0 = 4.96$ mg/kg.

Time (hour)	Peak Area	H ₂ in Soil (C) (mg/kg)	c/c ₀	Integration (C ₂ /C ₀ -C ₁ /C ₀)*t ₂
0	0.000	0.000	0	0
0.5	0	0.000	0	0
1	18.088	0.186	0.037402	0.037402
1.5	71.017	0.728	0.146847	0.164167
2	141.871	1.455	0.293356	0.293019
2.25	173.72	1.782	0.359212	0.148177
2.5	199.008	2.041	0.411502	0.130724
2.75	221.248	2.269	0.457489	0.126465
3	248.329	2.547	0.513486	0.167992
3.25	269.721	2.766	0.55772	0.143759
3.5	285.291	2.926	0.589915	0.112683
4	305.7185	3.135	0.632155	0.168957
4.25	329.778	3.382	0.681904	0.211435
4.5	350.768	3.598	0.725306	0.195311
4.75	369.112	3.786	0.763238	0.180173
5	388.053	3.980	0.802403	0.195828
5.25	409.748	4.202	0.847263	0.235516
5.5	425.169	4.361	0.87915	0.175379
5.75	444.397	4.558	0.918909	0.228614
6	461.248	4.731	0.953753	0.209064
6.25	474.469	4.866	0.981091	0.170862
6.5	480.1355	4.924	0.992808	0.076161
6.75	483.188	4.956	0.99912	0.042605
7	481.6182	4.940	0.995874	0
8	479.245	4.915	0.990967	0
10	480.799	4.931	0.99418	0
15	481.866	4.942	0.996387	0
				SUM= 3.414292 (Breakthrough time)

Plot the breakthrough curve with time as the x-axis and C/C_0 as the y-axis. The area surrounded by the breakthrough curve, the y-axis, and the $C/C_0=1$ line (as illustrated by the darkened area in the plot below), equals the breakthrough time.

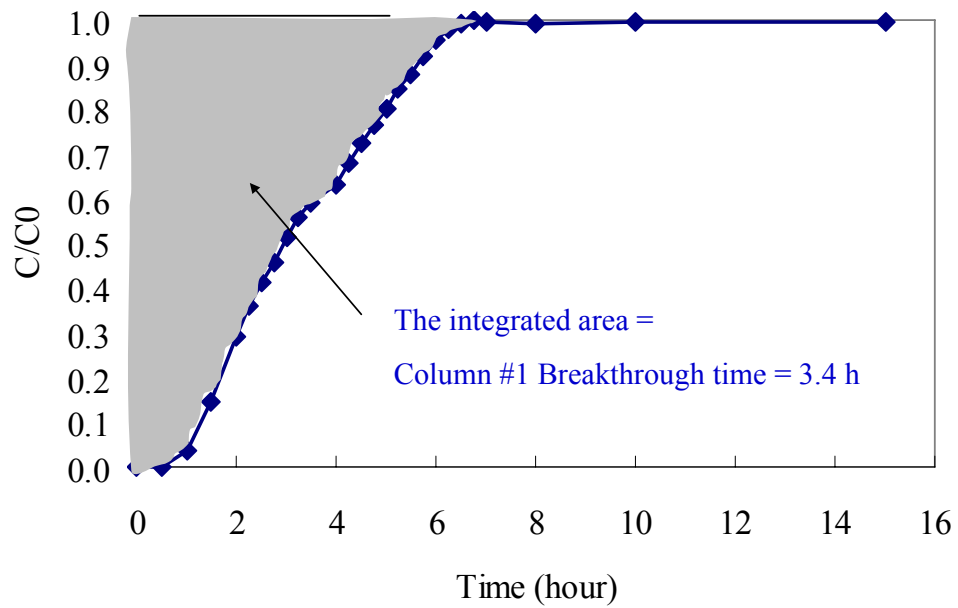

Meter Calibration Log
ESTCP Project ER-0511

Date	Carbon Dioxide (%)				Oxygen - low (%)				Oxygen - high (%)				Propane - low* (% or %LEL)				Propane - high* (% or %LEL)				Hydrogen (%)			
	Standard	Reading	Deviation	Recalibrated	Standard	Reading	Deviation	Recalibrated	Standard	Reading	Deviation	Recalibrated	Standard	Reading	Deviation	Recalibrated	Standard	Reading	Deviation	Recalibrated	Standard	Reading	Deviation	Recalibrated
4/7/2008	2.5	2.5	0.0%	N	0.0	0.0	#DIV/0!	N	12.00	12.00	0.0%	N	0.90	0.86	-4.4%	N	NA	NA	NA	NA	2.00	1.80	-10.0%	N
4/14/2008	2.5	2.44	-2.4%	N	0.0	0.0	#DIV/0!	N	12.00	12.00	0.0%	N	0.90	0.86	-4.4%	N	NA	NA	NA	NA	2.00	1.80	-10.0%	N
4/29/2008	2.5	2.38	-4.8%	N	0.0	0.0	#DIV/0!	N	12.00	12.10	0.8%	N	0.90	0.86	-4.4%	N	NA	NA	NA	NA	2.00	1.80	-10.0%	N
5/13/2008	2.5	2.58	3.2%	N	0.0	0.0	#DIV/0!	N	12.00	12.10	0.8%	N	49.00	50.00	2.0%	N	NA	NA	NA	NA	2.00	1.80	-10.0%	N
5/20/2008	2.5	2.6	4.0%	N	0.0	0.0	#DIV/0!	N	12.00	12.30	2.5%	N	49.00	50.00	2.0%	N	NA	NA	NA	NA	2.00	1.80	-10.0%	N
5/23/2008	2.5	2.4	-4.0%	N	0.0	0.0	#DIV/0!	N	12.00	12.20	1.7%	N	49.00	48.00	-2.0%	N	NA	NA	NA	NA	2.00	1.80	-10.0%	N
5/27/2008	2.5	2.7	8.0%	N	0.0	0.0	#DIV/0!	N	12.00	12.20	1.7%	N	49.00	51.00	4.1%	N	NA	NA	NA	NA	2.00	1.90	-5.0%	N
6/4/2008	2.5	2.5	0.0%	N	0.0	0.0	#DIV/0!	N	12.00	12.30	2.5%	N	49.00	48.00	-2.0%	N	NA	NA	NA	NA	2.00	1.80	-10.0%	N
6/12/2008	2.5	2.28	-8.8%	Y	0.0	0.0	#DIV/0!	N	12.00	12.30	2.5%	N	0.90	0.86	-4.4%	N	NA	NA	NA	NA	2.00	1.80	-10.0%	N
6/20/2008	2.5	2.48	-0.8%	N	0.0	0.0	#DIV/0!	N	12.00	12.00	0.0%	N	0.90	0.86	-4.4%	N	NA	NA	NA	NA	2.00	1.70	-15.0%	N
6/25/2008	2.5	2.42	-3.2%	N	0.0	0.0	#DIV/0!	N	12.00	12.00	0.0%	N	0.90	0.86	-4.4%	N	NA	NA	NA	NA	2.00	1.80	-10.0%	N
7/2/2008	2.5	2.4	-4.0%	N	0.0	0.0	#DIV/0!	N	12.00	11.80	-1.7%	N	0.90	0.86	-4.4%	N	NA	NA	NA	NA	2.00	1.70	-15.0%	N
7/7/2008	2.5	2.18	-12.8%	N	0.0	0.0	#DIV/0!	N	12.00	11.80	-1.7%	N	0.90	0.84	-6.7%	N	NA	NA	NA	NA	2.00	1.60	-20.0%	N
7/11/2008	2.5	2.46	-1.6%	N	0.0	0.0	#DIV/0!	N	12.00	11.90	-0.8%	N	0.90	0.86	-4.4%	N	NA	NA	NA	NA	2.00	1.70	-15.0%	N
7/18/2008	2.5	2.42	-3.2%	N	0.0	0.0	#DIV/0!	N	12.00	11.90	-0.8%	N	0.90	0.86	-4.4%	N	NA	NA	NA	NA	2.00	1.70	-15.0%	N
7/24/2008	2.5	2.4	-4.0%	N	0.0	0.0	#DIV/0!	N	12.00	11.90	-0.8%	N	0.90	0.86	-4.4%	N	NA	NA	NA	NA	2.00	1.80	-10.0%	N
7/31/2008	2.5	2.5	0.0%	N	0.0	0.0	#DIV/0!	N	12.00	11.90	-0.8%	N	0.90	0.86	-4.4%	N	NA	NA	NA	NA	2.00	1.80	-10.0%	N
8/7/2008	2.5	2.48	-0.8%	N	0.0	0.2	#DIV/0!	N	12.00	11.80	-1.7%	N	0.90	0.86	-4.4%	N	NA	NA	NA	NA	2.00	1.80	-10.0%	N
8/12/2008	2.5	2.48	-0.8%	N	0.0	0.0	#DIV/0!	N	12.00	11.80	-1.7%	N	0.90	0.86	-4.4%	N	NA	NA	NA	NA	2.00	1.80	-10.0%	N
8/18/2008	2.5	NA	#VALUE!	N	0.0	NA	#VALUE!	N	12.00	12.30	2.5%	N	0.90	0.82	-8.9%	N	NA	NA	NA	NA	2.00	1.80	-10.0%	N
9/8/2008	2.5	NA	#VALUE!	N	0.0	NA	#VALUE!	N	12.00	12.00	0.0%	N	0.90	0.86	-4.4%	N	NA	NA	NA	NA	2.00	1.60	-20.0%	N
9/15/2008	2.5	2.48	-0.8%	N	0.0	0.0	#DIV/0!	N	12.00	12.00	0.0%	N	0.90	0.94	4.4%	N	10.00	8.50	-15.0%	Y	2.00	1.70	-15.0%	N
9/29/2008	2.5	2.38	-4.8%	N	0.0	0.1	#DIV/0!	N	12.00	12.00	0.0%	N	0.90	0.94	4.4%	N	10.00	9.50	-5.0%	N	2.00	1.70	-15.0%	N
10/13/2008	2.5	2.36	-5.6%	N	0.0	0.0	#DIV/0!	N	12.00	12.00	0.0%	N	0.90	0.96	6.7%	N	10.00	10.00	0.0%	N	2.00	1.80	-10.0%	N
10/20/2008	2.5	2.4	-4.0%	N	0.0	0.0	#DIV/0!	N	12.00	12.00	0.0%	N	49.00	52.00	6.1%	N	10.00	10.00	0.0%	N	2.00	1.70	-15.0%	N
11/5/2008	2.5	2.48	-0.8%	N	0.0	0.1	#DIV/0!	Y	12.00	11.90	-0.8%	N	0.90	0.96	6.7%	N	10.00	10.00	0.0%	N	2.00	1.80	-10.0%	N
11/17/2008	2.5	2.36	-5.6%	N	0.0	0.0	#DIV/0!	N	12.00	11.80	-1.7%	N	0.90	0.94	4.4%	N	10.00	10.00	0.0%	N	2.00	1.70	-15.0%	N
12/1/2008	2.5	2.4	-4.0%	N	0.0	0.0	#DIV/0!	N	12.00	12.00	0.0%	N	0.90	0.96	6.7%	N	10.00	9.50	-5.0%	N	2.00	1.80	-10.0%	N

*iso-butane used as standard. Low level was reported either as percent (0.9%) or percent of LEL (49%)

LEL - Lower explosive limit

Soil Precision Results

Sample	Perchlorate		Nitrate		Moisture	
	µg/kg (dry)	RPD	mg-N/kg (dry)	RPD	%	RPD
Baseline						
P4-15-102907	25000	34%	6.4	11%	36	12%
P4-15-D	17647		5.7		32	
P4-40-102907	19403	4%	6.9	3%	33	28%
P4-40-D	18667		7.1		25	
CDM-INJ2-25-102607	5921	28%	5.0	24%	24	8%
CDM-INJ2-25-D	4459		3.9		26	
P2-05-102507	597222	25%	5.8	93%	28	10%
P2-05-D	463768		15.9		31	
P2-20-102507	242857	46%	15.7	6%	30	7%
P2-20-D	388889		16.7		28	
CDM-CB-1-041808-30	7018	96%	0.6	91%	31.6	70%
CDM-CB-1-041808-30D	2479		0.2		15.3	
CDM-CB-2-041808-30	2576	67%	0.2	24%	37.9	96%
CDM-CB-2-041808-30D	5196		0.1		13.4	
CDM-CB3-30-061008	3869	41%	0.1	146%	9.53	44%
CDM-CB3-30D-061008	5875		0.7		14.9	
CDM-CB4-30-061008	12135	16%	0.8	16%	9.35	11%
CDM-CB4-30D-061008	14192		1.0		8.4	
CDM-CB7-30-090208	8000	10%	0.9	6%	31.5	5%
CDM-CB7-30D-090208	8800		0.9		33	
CDM-CB8-30-090208	16000	51%	0.2	42%	4.4	43%
CDM-CB8-30D-090208	27000		0.2		6.8	
CDM-CB9-30-120208	150	7%	0.3	44%	11.3	18%
CDM-CB9-30D-120208	140		0.2		9.4	
CDM-CB10-30-120208	270	70%	0.2	40%	10.3	8%
CDM-CB10-30D-120208	130		0.2		9.5	
CDM-CB11-30-120308	23000	24%	0.1	26%	16.9	13%
CDM-CB11-30D-120308	18000		0.1		14.9	
CDM-CB12-30-120308	1400	57%	0.1	0%	9.3	5%
CDM-CB12-30D-120308	780		0.1		9.8	
CDM-CB13-30-120308	15000	0%	0.1	32%	11.4	6%
CDM-CB13-30D-120308	15000		0.1		10.7	
CDM-CB14-30-120308	1400	70%	0.1	50%	6.8	14%
CDM-CB14-30D-120308	2900		0.1		7.8	
CDM-CB15-30-120308	1200	91%	0.1	65%	9.1	6%
CDM-CB15-30D-120308	3200		0.1		9.7	
CDM-CB16-30-120308	13	0%	0.1	18%	25.6	9%
CDM-CB16-30D-120308	13		0.1		23.4	
CDM-CB17-30-120308	8800	26%	0.1	27%	11.60	20%
CDM-CB17-30D-120308	6800		0.1		9.50	
CDM-CB18-30-120308	7400	29%	0.1	21%	19.40	15%
CDM-CB18-30D-120308	9900		0.2		16.70	
CDM-CB19-30-120308	13000	43%	0.1	18%	7.50	3%
CDM-CB19-30D-120308	8400		0.1		7.70	

Notes

µg/kg - Micrograms per kilogram

mg-N/kg - Milligrams nitrogen per kilogram

RPD - Relative percent difference

Appendix E: Quality Assurance and Quality Control

This appendix includes specific QAQC-related information as specified in ESTCP guidance for the Final Report.

E.1 Calibration of Analytical Equipment

E.1.1 Field Instrumentation

Calibration checks of the H2scan and RKI field instruments were conducted in the field at the beginning of each day. Standards used for calibration included 0.0 percent oxygen, 12 percent oxygen, 2.5 percent carbon dioxide, 2.0 percent hydrogen, 0.9 percent iso-butane, and 10 percent iso-butane. iso-Butane was used as a standard for calibration of the propane sensor based on manufacturer recommendations and availability of the standard. The RKI instrument was very stable and generally did not require re-calibration. Readings were generally within five percent of the standard concentration. If these deviations were exceeded the instrument was recalibrated. Field instrument calibration procedures were performed in accordance with the manufacturer's recommendations. The H2scan instrument was also stable and readings were generally within 10 to 15 percent of the standard concentration. The H2scan was not capable of being field calibrated. A meter calibration log is included at the end of this Appendix

E.1.2 Laboratory Equipment Calibration

Pace Analytical Services Inc.⁴ conducted laboratory analyses. Initial and continuing calibration procedures for laboratory instruments were conducted in accordance with the laboratory's QA manual.

E.2 Quality Assurance Sampling and Analysis

Field duplicates were collected by the sampling team for analysis by the off-site laboratories. Field duplicates were collected to provide site-specific, field-originated information regarding the homogeneity of the sample matrix and the consistency of the sampling effort and to provide an assessment of precision including sampling and handling error. Field duplicates were collected at a frequency of approximately 10 percent of the total field samples (i.e. 1 field duplicate for every 10 field samples) and were collected concurrently with the field samples so as to equally represent the medium at a given time and location. A precision goal of 35 percent was established for soil samples.

Twenty-two complete data pairs (i.e., duplicate samples) were evaluated for precision and data are included at the end of this Appendix. Ten perchlorate data pairs (45 percent) exceeded the 35 percent goal and the greatest relative percent deviation (RPD) was 96 percent. Eight nitrate data pairs (36 percent) exceeded the 35 percent goal and the greatest RPD was 146 percent. Four moisture data pairs (18 percent) exceeded the 35 percent goal and the greatest RPD was 96 percent. While a significant percentage of data exceeded the RPD goals, these data are representative of a highly heterogeneous site and highlight the challenges in demonstrating soil

⁴Laboratory analyses were initially conducted by Laucks Testing Laboratories which was later acquired by Pace.

remediation technologies. These data are considered useable based on comparison of the observed RPD values to the performance goals of 90 percent contaminant removal. The worst case perchlorate of 96 percent RPD corresponded to concentrations of 7,018 and 2,479 $\mu\text{g}/\text{kg}$. If the greater value is assumed to be an “initial” concentration, a percent removal of 65 percent is calculated. This value is less than the 90 percent performance goal and thus observed removals of perchlorate were associated with actual degradation rather than heterogeneity. Similarly, the worst case perchlorate of 146 percent RPD corresponded to concentrations of 0.1 and 0.7 $\text{mg-N}/\text{kg}$. If the greater value is assumed to be an “initial” concentration, a percent removal of 86 percent is calculated. This value is less than the 90 percent performance goal and thus observed removals of nitrate were associated with actual degradation rather than heterogeneity.

E.3 Decontamination Procedures

Decontamination procedures used at the site were limited to drilling rig sampling equipment. The drilling rig and soil sampling components were decontaminated prior to arriving at the site. After each boring was completed, decontamination of all downhole drilling equipment and associated tools was performed. Equipment and tools were decontaminated by washing in a solution of Alconox or equivalent non-phosphate detergent, followed by a double rinsing with clean water. Excess soil on the drill rig and support vehicles was removed by steam cleaning, when appropriate. Pertinent field activities associated with drilling, well installation, and well development were documented in a field notebook in accordance with CDM Standard Operating Procedures described in the Quality Assurance Project Plan (Appendix C) of the Technology Demonstration Plan.

E.4 Sample Documentation

The sampling documentation program included field logbooks, data entry forms, photographs, chain-of-custody forms, and laboratory data. Field logbooks were used to document drilling events, site visits, material deliveries, and other pertinent project-related activities. Field logbooks and data entry forms included soil boring log forms, injection test monitoring forms, and instrument calibration forms. Laboratory data were received both electronically and in hard-copy formats. Data were transcribed to Excel spreadsheets for data analysis. Raw data are included in Appendix C. Digital photographs were taken periodically during the project to document site layout, equipment setup and configuration, and other technical aspects.

Appendix F: GEDIT General Engineering Guidance

1.0 Introduction

This document provides general engineering guidance for implementation of gaseous electron donor injection technology (GEDIT). It is organized as follows:

- Section 1 is this Introduction.
- Section 2 provides a description of the technology and its intended applications.
- Section 3 provides engineering design guidance include pre-design data and testing requirements.
- Section 4 provides information on operations of the process.
- Section 5 describes monitoring, sampling, and analysis requirements.
- Section 6 describes health and safety considerations.

This guidance does not purport to address all engineering, health and safety, or regulatory requirements for implementation of GEDIT. Professional engineering judgment and standard of care is required prior to implementation of GEDIT at any site. GEDIT is covered by U.S. Patent Number 7,282,149 and a patent pending.

2.0 Technology Description

GEDIT involves injection of gaseous electron donors into the soil with the purpose of promoting anaerobic bioremediation of perchlorate to water and chloride ion. This technology can be viewed as bioventing in reverse as illustrated in Figure 1. Bioventing, a proven bioremediation technology, involves the injection of a gaseous electron acceptor (e.g., oxygen) into the vadose zone resulting in the biodegradation of an electron donor (e.g., hydrocarbons). In the present application, the electron acceptor and donor are reversed with the gaseous electron donor being injected in order to biodegrade the electron acceptor.

Bioventing is an effective technology because it relies on the excellent mass transfer characteristics of gases and their ability to distribute oxygen through the vadose zone. Similarly, the injection of gaseous electron donors for perchlorate biodegradation in vadose zone soil benefits from these same gas mass transfer and distribution characteristics. The superior mass transfer and distribution of gases as compared to liquids is the major advantage of this technology over current attempts to introduce liquids into the vadose zone. Diffusion of gases in the vadose zone improves the ability to deliver the electron donor throughout the soil volume and helps to overcome problems associated with liquid flow through preferential pathways. Additionally, gaseous electron donor technology does not require the capture and treatment of infiltrated liquids that could otherwise adversely impact groundwater.

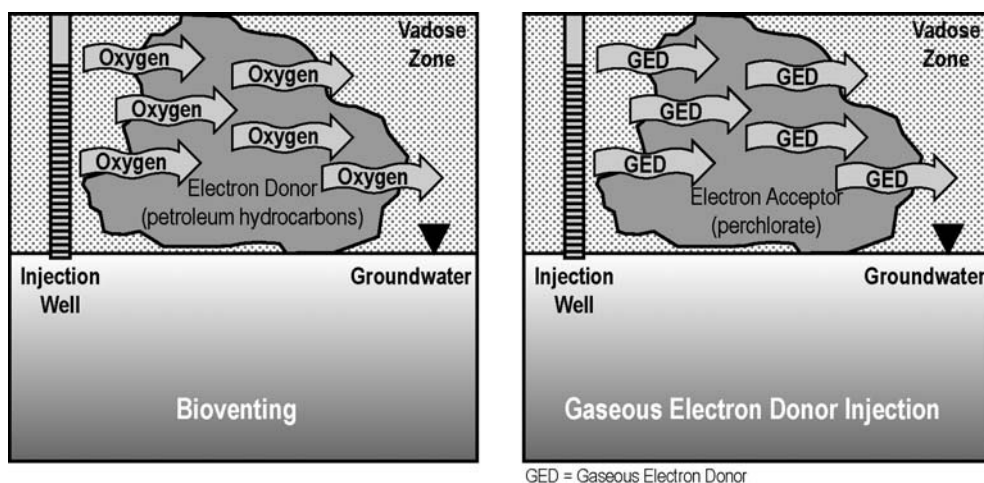

Figure 1 – Comparison of Bioventing and Gaseous Electron Donor Injection Technology

GEDIT involves injection of gaseous electron donors into the soil using injection wells in combination with optional soil vapor extraction wells. These gaseous electron donors can include hydrogen, propane, or volatile organic compounds such as methanol, ethanol, butanol, acetic acid, ethyl acetate, butyl acetate, hexene, etc. The injected concentration of the electron donor is less than its saturation vapor pressure so that the injected electron donor truly exists as a gas and not as a mist. As the gaseous electron donor material is injected into the vadose zone it partitions between soil moisture and the vadose zone pore space. After it has partitioned into the soil moisture, anaerobic, perchlorate-reducing bacteria can use the electron donor to reductively

degrade perchlorate. Any soil nitrate or oxygen that is present in the pore space will first be reduced using the injected gaseous electron donor. The remaining electron donor will be available for use by perchlorate-reducing bacteria. The rate at which the gaseous electron donor is transported through the vadose zone is primarily a function of soil moisture, electron donor Henry's constant, void volume, bulk soil density, bulk gas velocity, soil permeability, and biodegradation rate (Evans and Trute, 2006). GEDIT is similar to anaerobic bioventing (U.S. EPA, 2006b). Anaerobic bioventing has been described to involve injection of hydrogen and carbon dioxide into soil to promote anaerobic biodegradation of organic contaminants including chlorinated hydrocarbons and dichlorodiphenyltrichloroethane (DDT). GEDIT can include use of hydrogen/carbon dioxide and can additionally use liquid electron donors that can be vaporized into a gaseous carrier stream. In addition, GEDIT was developed specifically for treatment of perchlorate.

GEDIT can be implemented in various configurations two of which are illustrated in Figures 2 and 3. In the gas injection configuration, nitrogen from a generator or a liquid nitrogen supply is amended with gaseous electron donor and then injected into the perchlorate-impacted vadose zone. The presence of nitrogen serves to flush oxygen from the soil gas, enhancing conditions for the degradation of perchlorate. In the SVE configuration, soil vapor is extracted, amended with gaseous electron donor, and then injected back into the perchlorate-impacted vadose zone. As the reductive degradation of perchlorate progresses, the oxygen content of the extracted soil is reduced, thereby facilitating further perchlorate degradation. Well spacing for both of the configurations will depend on the pneumatic radius of influence and the specific gaseous electron donor selected for use.

Potential applications of GEDIT include treatment of a wide variety of oxidized contaminants in soil. A partial list of oxidized contaminants that are potentially treatable using GEDIT include:

- Perchlorate
- Chlorate
- Nitrate
- Nitrite
- Selenate
- Arsenate
- Chromate and dichromate (i.e., hexavalent chromium)
- Uranyl
- Peractin
- N-Nitrosodimethylamine (NDMA)
- Trichloroethene (TCE)
- Trichloroethane (TCA)
- Highly energetic compounds including nitro-aromatics such as TNT, RDX, and HMX.

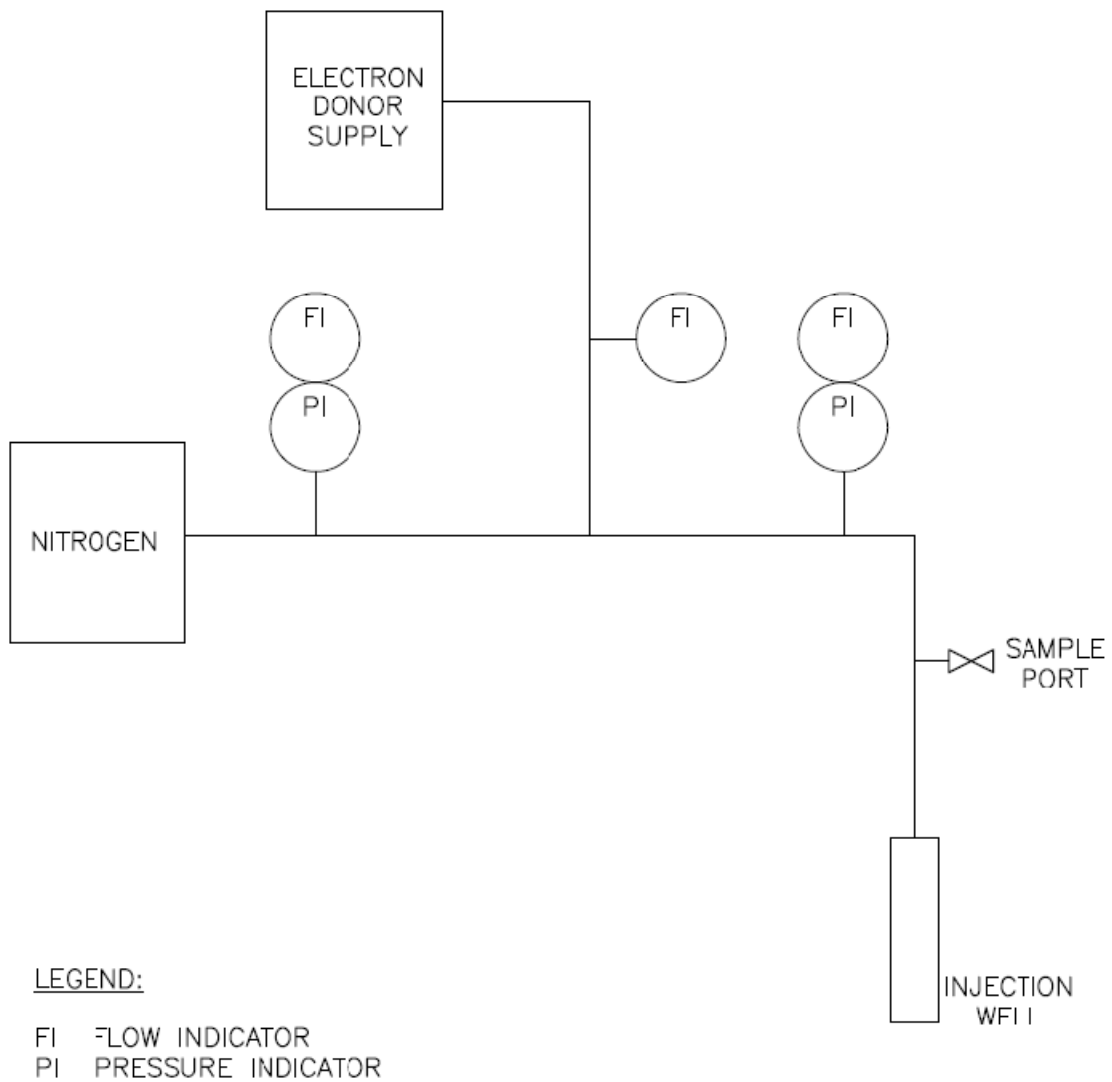
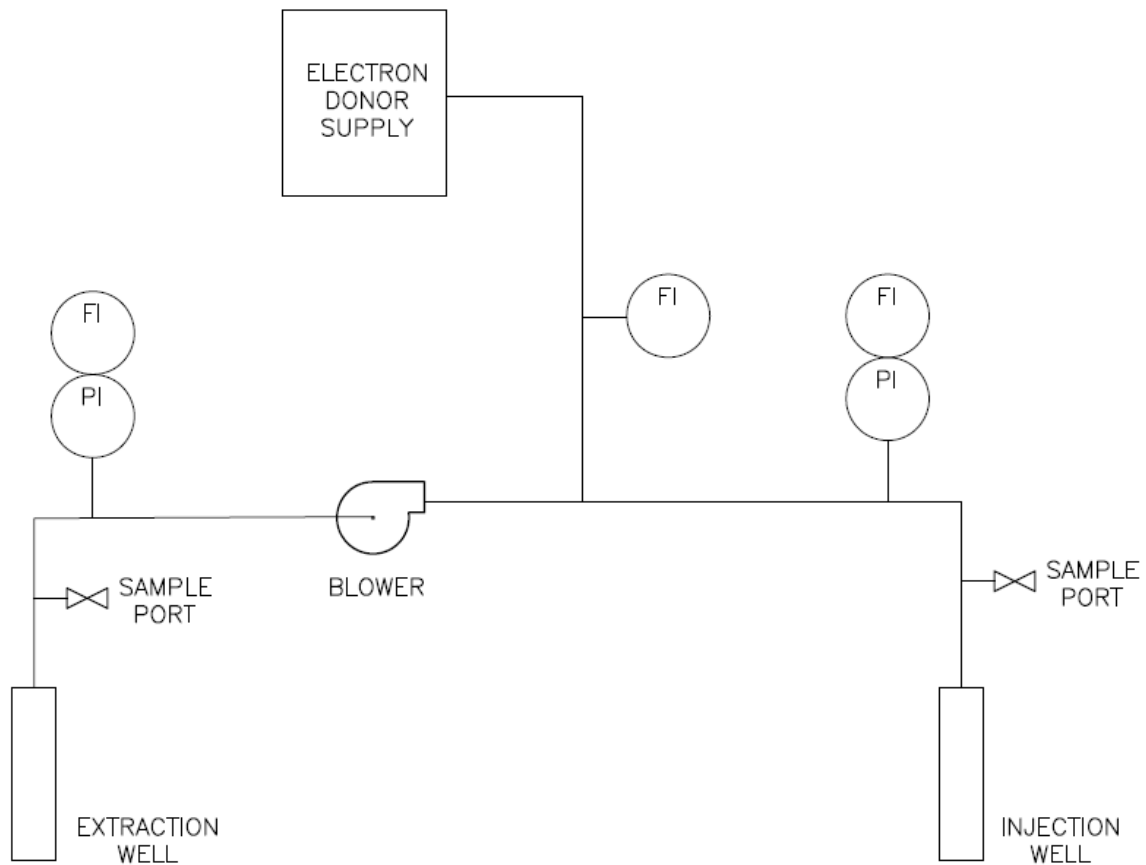

Figure 2 – Example Gas Injection GEDIT Process and Instrumentation Diagram



LEGEND:

- FI FLOW INDICATOR
- PI PRESSURE INDICATOR

Figure 3 – Example SVE GEDIT Process and Instrumentation Diagram

3.0 Engineering Design

This section includes engineering design considerations for injection wells, monitoring piezometers, process equipment, and instrumentation and controls. It also includes a description of pre-design data and testing requirements.

3.1 General Design Considerations and Approach

The GEDIT process should be designed with the objective of minimizing oxygen concentrations and distributing sufficiently high concentrations of the gaseous electron donor(s) throughout the vadose zone. The absolute concentrations of oxygen and electron donors that are required are dependent on the particular contaminant of concern.

In general, contaminants that have a greater free energy for reduction (e.g., nitrate and chromate) will require lower oxygen concentrations than contaminants with a lower free energy for reduction (e.g., perchlorate, selenate, and uranyl). With respect to perchlorate, oxygen concentrations less than 1 percent appeared to be sufficient to promote biological reduction based on demonstration results. With respect to nitrate, greater concentrations – 10 percent or greater – were sufficiently low to support biological reduction.

The particular electron donor type and concentration are also dependent on the particular contaminant of concern. Hydrogen was determined to be required for perchlorate reduction whereas liquefied petroleum gas (LPG) was sufficient for nitrate reduction. The minimum concentration of hydrogen necessary to support perchlorate reduction was 0.5 percent. Carbon dioxide may also be required to support growth of autotrophic bacteria during contaminant degradation with the electron donor hydrogen. The requirement for carbon dioxide is site-specific and depends in part on the natural alkalinity (i.e., bicarbonate and carbonate) present in site soil. The minimum concentration of LPG necessary to support nitrate reduction was not determined but may be as low as 1 percent.

Achieving these concentrations of oxygen and electron donor(s) requires injection of the electron donor(s) and possibly other gases such as nitrogen and/or carbon dioxide. Reduction of oxygen concentrations in the vadose zone can occur via two processes: displacement and aerobic biodegradation. Displacement can be accomplished using any gas though certain gases are more effective than others. For example, because of varying densities, hydrogen floats, LPG sinks, and nitrogen does neither. Thus injection of nitrogen is effective at oxygen displacement horizontally from the point of injection, hydrogen is effective at oxygen displacement vertically upward from the point of injection, and LPG is effective at oxygen displacement vertically downward from the point of injection. Gaseous electron donors such as hydrogen and LPG can also remove oxygen when they are biodegraded by aerobic bacteria. These bacteria use hydrogen and LPG as electron donors and consume oxygen during the biodegradation process.

Other general considerations include soil lithology, permeability, and moisture content. The lithology and permeability will affect bulk transport of gas and diffusive transport of the electron donor. Permeability will also affect the rate of back diffusion or advection (e.g., barometric pumping) of oxygen into the treatment zone. Hydrogen is a small molecule with high diffusivity. Thus it has greater potential to diffuse into low permeability soils. Based on demonstration

results, GEDIT was determined to be effective in both low and high permeability soil types. Therefore, GEDIT is applicable to all soil lithologies; however, the design and operating conditions will likely vary and be site-specific. Moisture content often correlates with soil lithology. Moisture can affect permeability and also affects biological activity. Very low moisture contents can be inhibitory to biological activity. Based on demonstration results, acceptable perchlorate biodegradation was observed with soil moisture as low as 7 percent. This concentration may not be translatable to other sites and the minimum moisture content may be dependent on the soil lithology. Thus the minimum moisture content must be determined experimentally in a treatability test. This test will also serve to determine if other inhibitory compounds are present in the soil.

Recommended approaches to GEDIT design based on these general guidelines are described in the following sections.

3.2 Pre-Design Testing and Data Requirements

Laboratory treatability testing and field pilot testing are recommended as part of the GEDIT design process. Laboratory treatability testing is used to select electron donors, electron donor concentrations, and determine soil moisture limits. Field pilot testing is used to determine site permeability and gas flow rate requirements.

3.2.1 Laboratory Testing

Soil microcosms are recommended to determine electron donor requirements and soil moisture limitations. In addition, microcosms can give an indication of the potential rate and extent of contaminant degradation. Detailed procedures for conducting the microcosms are included in the ESTCP Final Report. The general approach for conducting testing is presented here.

Prior to conducting the laboratory testing it is helpful to have an indication of the range of lithologies and moisture contents in vadose zone soil at the site and the range of contaminant concentrations. In addition, since contaminant concentration can be correlated with lithology and/or moisture content (e.g., perchlorate being associated with finer grained soil that also have higher moisture content), an understanding of such a correlation is helpful. The variation in soil lithology, moisture content, and contaminant concentration will determine the number of soil types and moisture contents that should be evaluated during the treatability test. Testing a minimum of two moisture contents is recommended. These ideally would be representative of low and high moisture contents in soil at the site where contaminant concentrations are well in excess of cleanup levels.

Soil for the microcosms is preferably collected by drilling or excavation immediately prior to setup of the treatability test. Soil is then homogenized and moisture content is adjusted if necessary. Increasing moisture is conducted by adding distilled water to the soil followed by homogenization. Soil drying in air can be conducted if the soil is too moist, however, collection of soil that is representative of low moisture content conditions is preferable. Following adjustment of moisture and homogenization the soil is placed in serum bottles (e.g., 50 grams in a 250-mL serum bottle) or other air-tight container with septa. Thick butyl rubber septa are inserted into the serum bottles and a gas manifold is used to replace the air in the serum bottle

headspace with the desired gas mixture. The number of gas mixtures to be tested will be dependent on contaminant of concern and the desired scale of the study. For perchlorate the minimum recommended gas compositions are 1) 100 percent nitrogen (control), 2) 1 percent hydrogen in nitrogen, 3) 1 percent hydrogen plus 1 percent carbon dioxide in nitrogen, 4) 10 percent hydrogen in nitrogen, and 5) 10 percent hydrogen plus 1 percent carbon dioxide in nitrogen). Multiple bottles are setup for each condition to allow sacrificial sampling and replication. At a minimum 10 bottles should be setup for each condition.

Sampling and analysis of the headspace is conducted for oxygen (i.e., to verify its absence) and electron donor(s). Sampling and analysis of soil contaminants requires sacrificial sampling of the microcosms and analysis using standard analytical methods such as distilled water extraction and ion chromatography for perchlorate.

Results are evaluated with respect to rate and extent of contaminant degradation relative to the control. If multiple experimental conductions are capable of promoting contaminant degradation, then economic and engineering analyses are recommended to identify which electron donor should be used in the field.

3.2.2 Field Pilot Testing

Field pilot testing is recommended to determine optimal operating conditions for gas injection and quantify radius of influence. In addition, pilot testing can be conducted to evaluate different injection well designs. The demonstration included a pilot test to evaluate soil pneumatic permeability and an optimization test to evaluate different well designs and injection configurations. Detailed procedures for conducting these tests are included in the ESTCP Final Report. The general approach for conducting testing is presented here and is based on lessons learned from the demonstration.

The optimized injection well design for the ESTCP demonstration is shown in Figure 4.⁵ This design is based on use of 6-inch porous vapor probes embedded in sand packs and located every 10 feet of boring depth. This design is recommended as a starting point but may not be optimal for all sites. The injection well design is also recommended for the soil gas monitoring piezometers. This approach allows use of piezometers as injection wells if desired. Injection wells and piezometers should be installed in different lithologic zones to allow assessment of soil types on gas injection. A minimum of one injection well and two piezometers is recommended for the pilot test. The depth and number of vapor probes will be dependent on site lithology and heterogeneity but a minimum of four probes per well/piezometer is recommended.

The recommended basic pilot test approach involves injection of nitrogen. Nitrogen can be supplied using a nitrogen generator, in liquefied form, or in multiple cylinders. Nitrogen is injected at one or more depths in the injection well at pre-determined flow rates and oxygen is monitored in the piezometers at all depths. A recommended starting flow rate is 50 ft³/min at each injection well depth. Oxygen is monitored in the piezometers to determine which operating conditions result in the maximal reduction of oxygen concentration. Analytical equipment for monitoring oxygen is discussed in Section 5.2. Various conditions are tested to identify the

⁵ Note that for the ESTCP demonstration the injection well (i.e., P4) was called a piezometer.

optimal operating condition that maximizes the radius of influence for oxygen displacement and minimizes gas flow. Pressures are also measured at the injection well and at the piezometer.

The next recommended level of pilot testing involves use of selected gaseous electron donors in addition to nitrogen. This level of pilot testing can be important because of the tendency of certain electron donors to float (e.g., hydrogen) or sink (e.g., LPG). A manifold will be necessary to adjust flow rates of each gas and mix the gases prior to injection. Monitoring of individual gases at the piezometers may require additional analytical equipment. Analytical equipment for monitoring electron donors is discussed in Section 5.2.

Analysis of pilot test results will involve determination of the optimal operating conditions (e.g., flow rate, injection pressure, gas composition, injection depths, etc.) required to maximize the radius of influence and minimize gas flow rate. The radius of influence is the maximum distance from point of the injection where oxygen and electron donor concentrations are acceptable based on laboratory test results or other pertinent data.

3.3 Wells and Piezometers

Design of gas injection wells and monitoring piezometers will be based on pilot test results, standard practices for well design, and applicable regulations. Figure 4 illustrates the injection well/piezometer design used for the ESTCP demonstration. This design is recommended as a starting point but site specific lithology and advances in understanding of gas injection for GEDIT will likely lead to modifications of this design.

The number and location of injection wells will be dependent on the area and depth requiring treatment, pilot test results, and economic evaluations. Pilot test results will establish the radius of influence for injection using a single well unless a multiple-well pilot test is conducted. A single well pilot test does not account for potential efficiencies of using multiple wells. Nevertheless, conservative well spacing based on the experimentally determined radius of influence is recommended. Potential for gas migration along subsurface utilities or into basements and buildings should also be considered when selecting injection well and piezometer placement.

The number and location of piezometers will be based on pilot test results, site heterogeneity, regulatory requirements, and cost. Piezometers in general should be located equidistant from injection wells. At a minimum, the number of piezometers should be selected to allow monitoring of site heterogeneity effects on gas transport.

The ESTCP demonstration design included 1/2-inch and 3/8-inch diameter (OD) poly tubing with 1/2-inch diameter by 6-inch long stainless steel vapor sampling probes. This design was used for gas injection and monitoring. The tubing diameter for injection wells may need to be increased if flows significantly greater than 50 scfh are used.

3.4 Process Equipment

GEDIT process equipment includes the gas supply, the gas mixing manifold, and the gas distribution system. Each of these process equipment categories are discussed below. The

process and instrumentation diagram (P&ID) for the ESTCP demonstration is presented in Figure 5. This P&ID illustrates the three process equipment categories that are described in detail in the following sections.

3.4.1 Gas Supply

Gas supply equipment will be dependent on the particular gas mixture composition and flow rate. Depending on the total flow rate required, some supply configurations will be more appropriate and cost-effective than others. For example, relatively low flow rates of gases will be better suited through use of gas cylinders or liquefied gases. Relatively greater flow rates will be better suited through the use of gas generators. The best gas supply configuration will be determined by conducting an engineering analysis of alternatives.

Nitrogen can be supplied as a compressed gas, a liquefied gas, or via various air separation systems. Compressed nitrogen is typically provided in cylinders that contain about 228 (K cylinder) or 304 (T cylinder) cubic feet of gas each. These cylinders can be manifolded together but in general will not be capable of supplying sufficient nitrogen for most GEDIT applications. Liquefied nitrogen was used during the ESTCP demonstration and was contained in a portable trailer with a capacity of 150,000 standard cubic feet. Larger liquefied nitrogen storage systems are available (e.g., 1.2 million standard cubic feet) but these are not portable. Nitrogen generators can be used to produce high purity nitrogen from air. Two primary types of generators are available: pressure swing adsorption (PSA) and membrane. PSA generators use two alternating trains of molecular sieves to separate nitrogen from oxygen. One train is separating the gases while the other is being regenerated. Membrane separators continuously generate nitrogen via diffusive separation in specialty membranes. Both of these nitrogen generators are capable of generating high flow rates of high purity nitrogen but require electricity to operate. They also require air compressors to operate. The nitrogen purity is also dependent on the design and operation of each system. Greater nitrogen purity will require more costly equipment and will increase operating costs.

Hydrogen can be supplied as a compressed gas, a liquefied gas, or via various generation systems. Compressed hydrogen is typically provided in cylinders that contain about 195 (K cylinder) or 261 (T cylinder) cubic feet of gas each. These cylinders can be manifolded together and 18-packs of K cylinders were used in the ESTCP demonstration. Larger volumes of hydrogen can be supplied using compressed hydrogen tube trailers or liquefied hydrogen tanks. Hydrogen can also be generated electrolytically or via reformation. Electrolytic hydrogen generators convert distilled water to hydrogen and oxygen using electricity. The hydrogen and oxygen are separated. Hydrogen reformers use a fuel such as methane or propane to produce hydrogen under high temperature and pressure. These systems require the fuel and electricity.

Liquefied petroleum gas (LPG) can be used as a gaseous electron donor and/or as a carrier gas. LPG is commonly available and typical odorized organosulfur compounds such as ethyl mercaptan. LPG cylinders are available in a variety of volumes.

Other electron donors are conceivable and may include organic compounds that are liquid at room temperature such as ethyl acetate or 1-hexene and can be supplied in drums. These liquids would be vaporized in a nitrogen carrier gas prior to injection. Carbon dioxide may be required

as a carbon source when using hydrogen as an electron donor. Carbon dioxide is available in cylinders and is liquid at room temperature when compressed. A K cylinder of carbon dioxide contains 560 standard cubic feet of gas.

A major consideration in evaluation of gas supply options is availability of utilities. Compressed and liquefied gases do not require electricity or water. This is an advantage for implementation at remote sites that do not have ready access to utilities. Electricity can be generated but may require significant fuel (e.g., diesel) storage. Distilled water can be generated from groundwater following pretreatment (e.g., ion exchange, reverse osmosis) but may necessitate brine disposal.

The gas supply configuration that was used for the ESTCP demonstration is shown in Figure 6. This configuration included liquefied nitrogen (150,000 standard cubic feet capacity), three 18-packs of hydrogen K cylinders, one 18-pack of carbon dioxide K cylinders, and a 120-gallon tank of LPG. This configuration was used to supply 100 standard cubic feet per minute of a gas mixture comprised of 89 percent nitrogen, 10 percent hydrogen, 10 percent LPG, and 1 percent carbon dioxide. A cylinder of helium is also shown in Figure 6 but this was used only for initial tracer tests and is not considered part of the standard gas supply configuration.

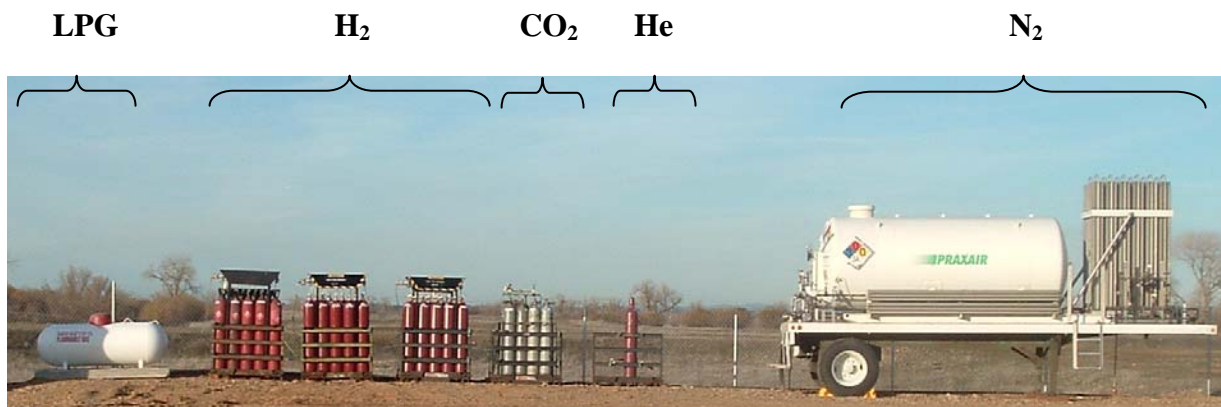

Figure 6 – Gas Supply for the Demonstration

3.4.2 Gas Mixing Manifold

A gas mixing manifold is required to allow control of individual gas flow rates and generate a gas mixture of the desired composition at the desired total flow rate. The manifold design will be dependent on the specific gas mixture and flow rates but will in most cases include the following elements:

- Connections from the gas supplies to the manifold
- On-off valves to control flow of the gas supplies
- Flow meters to monitor flow rate of individual gases and gas mixtures
- Pressure gauges to monitor pressures of individual gases and gas mixtures
- A static mixer or other device to ensure the gases are well mixed prior to distribution to the injection wells
- A sample valve to allow collection of samples for on-site or off-site gas analysis
- Connections from the manifold to the gas distribution system



Figure 7 – Gas Supply Control Panel

Figure 7 includes photographs of the front and back of the manifold used for the ESTCP demonstration. This design is based on the P&ID presented in Figure 5. Alternative designs including use of non-metallic tubing suitable for compressed gases (i.e., not PVC) may be appropriate. The design of the ESTCP demonstration manifold piping was based on the Compressed Gas Association (CGA) Standard for Hydrogen Piping Systems at Consumer Locations (G-5.4-2005) which states that 300 series stainless or carbon steel shall be used for piping. A professional engineer should be consulted with regard to local code requirements and whether this particular standard applies to a specific application and in particular to gas mixtures containing low percentages of hydrogen.

Other considerations for gas mixing manifold design include:

- Installation location – Locate the manifold outside rather than inside a building or container so potential gas leaks have a greater potential for dispersion.
- Automation – Consider whether manual or automatic monitoring and control is desired. One factor that will affect the need for automation is whether the gaseous electron donor will be injected continuously or pulsed. Automatic monitoring and control of flow will increase capital costs but has the potential to reduce operating costs. Also, use of electronic sensors and controls while using a potentially flammable electron donor gas mixture will need to comply with electrical classification requirements under the National Electrical Code.
- Rotameter correction – Ensure that readings from variable area flow meters – also known as rotameters – are appropriately compensated for pressure and gas composition. Most rotameters are calibrated for air at ambient pressure.
- System pressure – Calculate the saturation pressure for gas mixtures containing condensable gases (e.g., LPG) and ensure that the operating manifold system pressure is less than the saturation pressure to prevent condensation.
- Multiple gas mixtures – Determine during pilot testing whether different gas compositions will be injected at different depths. For example, it may be desirable to inject hydrogen at deeper locations and LPG at shallower locations. With this approach hydrogen can float up through the zone of influence and LPG can sink. Multiple gas mixtures will require multiple gas mixing manifolds.

3.4.3 Gas Distribution System

The gas distribution system is used to transfer the gas mixture from the gas mixing manifold to the injection well(s) in a GEDIT design based on gas injection only. A GEDIT design that is based on soil vapor extraction, electron donor amendment, and re-injection will have additional requirements. The ESTCP demonstration was based on the gas injection approach and this section addresses this approach. The design of this system will depend on gas flow rates, the distance from the gas mixing manifold to the injection wells, and site-specific constraints such as vehicle traffic and security.

The ESTCP demonstration used 3/8-inch diameter tubing for the distribution system with pneumatic quick-connect fittings for connection to wellhead tubing. The tubing was laid on the ground which may not be applicable for all sites. Alternatively, tubing can be run through metallic or plastic pipe or conduit for greater security. If necessary the tubing can be buried. Regardless, pressure drop is a primary consideration and must be calculated to determine the appropriate tubing size. The pressure drop must be sufficiently low to prevent too high a gas pressure at the gas distribution system (see Section 3.4.2) and sufficiently high to ensure delivery to each well point (see Section 3.2.2). Gas distribution tubing or piping materials must be suitable for use with compressed gases. For example, PVC pipe should never be used with compressed gas systems.

4.0 Operations

Operational requirements of the GEDIT system will be specific to the particular design. However, several operational considerations can be generalized for most systems and are described below. These considerations are focused on optimization of operating conditions to minimize gas use and ensure that subsurface conditions are suitable.

Operating variables for a GEDIT system associated with process optimization include the following:

- Injection wells where gas is injected
- Depths in each well where gas is injected
- Gas flow rate for each injection location
- Gas composition for each injection location
- Gas injection strategy – continuous or pulsed
- Total time that gas is injected at each point

Other operating considerations include the following:

- Ensuring that gas supplies are sufficient and refilled or maintained accordingly
- Maintaining the system to ensure that leaks are identified and repaired
- Adjusting flow rates and gas compositions as necessary to ensure that the actual values are in line with the target values

Process optimization will necessitate monitoring of operating conditions and sampling and analysis of soil vapor and soil (see Section 5.0 for details on monitoring, sampling, and analysis). The objective of process optimization is to minimize gas use while ensuring that the soil vapor composition meets pre-determined specifications. The gas composition specifications will be determined during bench-scale and field-scale testing (see Section 3.2). In general, operating conditions will be adjusted to ensure that, at each monitoring location, oxygen concentrations will be less than a specified maximum value and electron donor concentration(s) will be greater than a specified minimum value. Additionally, operating conditions will be optimized to minimize gas use while meeting these specified gas concentrations at all piezometer locations. Analytical data from individual piezometer gas samples will be used to identify specific injection wells and depths where gas flow rates and/or compositions should be adjusted to meet gas composition specifications. The number and locations of installed piezometers will directly affect the extent to which process optimization can be accomplished.

Sampling and analysis of soil gas is conducted to determine whether the soil gas composition is supportive of contaminant biodegradation. It is not a direct measurement of contaminant biodegradation. For nonvolatile contaminants (e.g., perchlorate) collection of soil samples is the only means to assess contaminant biodegradation.⁶ Sampling of soil requires drilling and must be conducted judiciously. Heterogeneity can also complicate data analysis. Nevertheless, analysis of

⁶ *In situ* microcosms can be considered but representativeness of the results would need to be established.

soil samples and comparison to cleanup goals will ultimately determine whether GEDIT operation is complete or continued gas injection is necessary.

5.0 Monitoring, Sampling, and Analysis

5.1 Process Monitoring

Process monitoring variables will include at a minimum flow rates, pressures, and gas composition being delivered to the injection wells. Additional process monitoring variables, depending on the GEDIT design, will include gas supply pressures or tank levels, fuel levels in the case of on-site power generation, and likely other parameters.

Monitoring of flow rates will depend on the actual flow meter being used. In the case of rotameters, corrections for gas composition and pressure may be necessary. Rotameters are typically calibrated for air at atmospheric pressure. Rotameter readings are affected by gas pressure and density. The rotameter readings must be corrected when measuring the flow rate of gases other than air and at pressures other than atmospheric. The following equation⁷ can be used to make these corrections:

$$Q_i = CF_i \widehat{Q}_i \sqrt{\frac{P_i}{P}}$$

where,

Q_i is the actual flow rate of gas i (i.e., H₂, N₂, CO₂, or LPG) in units of scfm or scfh;

CF_i is the correction factor for gas i and is based on the relative densities of gas i and the rotameter calibration gas (i.e., air). The values of CF_i are specific to the gas composition and the rotameter and are presented in Table 1;

\widehat{Q}_i is the rotameter reading for gas i in units of scfm or scfh;

P_i is the absolute pressure of gas i at the rotameter; and

P is the atmospheric pressure (1 atmosphere or 14.696 psia).

Table 1 – Correction Factors for Key Instruments Rotameters

i	CF_i
N ₂	1.02
Propane (LPG)	0.80
H ₂	3.81
CO ₂	0.81

Monitoring of pressure can be conducted using standard pressure gauges. Monitoring of gas composition in the gas mixing manifold is described in Section 5.2.

⁷ Provided by Key Instruments.

Process monitoring can be conducted manually as described above or automatically using flow and pressure transmitters. These will increase capital costs but have the potential to decrease lifecycle costs through more cost-effective monitoring and control. These transmitters may need to be intrinsically safe or enclosed in explosion proof housings depending on the electrical classification of the area.

5.2 Gas Sampling and Analysis

Gas samples from the gas mixing manifold and the piezometer can be manually collected and analyzed using field instruments. Alternatively, samples can be submitted to a laboratory for analysis. Specialized instruments can also be used to continuously monitor gas composition.

The ESTCP demonstration involved manual sampling and use of field instruments. Figure 8 is a photograph of the field sampling and analysis equipment used for the demonstration. This equipment was suitable for sample collection and analysis of oxygen, propane, hydrogen, temperature, and relative humidity. Oxygen, propane, and carbon dioxide were monitored using an RKI Eagle gas monitor. This instrument included a gas sampling pump that drew soil gas from the piezometers and had the following sensors:

- Oxygen was measured using an electrochemical cell.
- Propane was quantified using an infrared sensor which allowed specific quantification without interference from hydrogen.
- Carbon dioxide was measured using an infrared sensor.

Hydrogen was monitored using a H2SCAN HY-ALERTA 500. This instrument is specific for hydrogen. Relative humidity and temperature were monitored using Vaisala HMT360 meter.

The RKI Eagle was determined to be a robust and cost-effective field instrument capable of measuring multiple gasses during GEDIT operation. Alternative portable instruments are also available. When selecting an instrument for use it is important to determine the effect of varying oxygen concentrations on the quantification of electron donor concentrations. For example, use of a flammability sensor that measures percentage of the lower explosion limit (LEL) might be considered for use. However, most of these sensors employ catalytic bead technology which requires the presence of oxygen to function. Since depletion of oxygen is necessary for GEDIT, this type of an instrument is not suitable for electron donor analysis. Use of an infrared sensor for measurement of hydrocarbons is suitable and is unaffected by oxygen. Use of a hydrogen-specific sensor such as the H2SCAN HY-ALERTA 500 is suitable for hydrogen measurement and was determined to be minimally affected by oxygen.



Figure 8 – Gas Sampling and Analysis Train

5.3 Soil Sampling and Analysis

Soil sampling and analysis is required for overall determination of GEDIT effectiveness unless the contaminant of concern is volatile. Methods for conducting soil sampling and analysis are well established and are not discussed further. On the other hand, soil heterogeneity is an important consideration when selecting soil sampling locations. If calculation of percent contaminant removal is of interest then it is important to collect before and after samples as close to each other as possible. The reason for this approach is to minimize effects of heterogeneity on data interpretation. If determination of whether soil concentrations are below a cleanup level then grid sampling or other standard sampling techniques are appropriate.

When collecting samples for analysis, discrete samples are recommended. Analysis of these samples for the contaminant(s) of concern and moisture is recommended to allow determination of the effects of moisture on contaminant removal. In addition, the soil type should be characterized using the Unified Soil Classification System (USCS) or a grain size analysis should be conducted.

6.0 Health and Safety

Health and safety considerations must be addressed during design, construction, and operation phases. Issues that must be considered include but are not limited to:

- Flammability hazards including requirements for electrical classification
- Energy hazards including pressure
- Cold exposure hazards when handling liquefied gases
- Vapor intrusion issues when injecting gases into the subsurface
- Oxygen deficient atmosphere hazards
- Drilling hazards
- Construction hazards
- Secondary containment requirements
- Contaminant exposure hazards

These and other issues as appropriate must be addressed early on during the design process. Design of the process by a licensed professional engineer is required. Depending on local regulatory requirements, a hazardous materials plan may be required. During operation, regular monitoring of the working environment for oxygen and LEL will be necessary and should be specified in the site health and safety plan. Regular checking of the GEDIT process equipment and piping for leaks using suitable instruments is also necessary.

Factors that affect this optimization will include:

- Number of injection wells – The optimal number of injection wells will be a balance of well installation costs and gas consumption. More wells spaced closely together will allow use of lower gas flow rates. While this plan specifies the number and placement of wells based on pneumatic air injection tests, the data obtained during this demonstration will be used to develop optimization strategies for well placement in future applications of the technology.
- Gas flow rate – Increasing gas flow rates will maximize radius of influence but will result in greater costs because of greater gas consumption rates.
- Oxygen infiltration rate – The rate of oxygen infiltration will be influenced by variations in barometric pressure, soil permeability, and diffusion.
- Electron donor consumption rate – The rate of electron donor consumption will be influenced by the rate of oxygen infiltration, soil moisture, and biological activity.
- Gas injection pulsing duration and frequency – Gas injection pulsing will minimize costs by allowing use of greater gas flow rates while minimizing gas consumption. However, the rate of electron donor consumption and the rate of oxygen infiltration will limit the duration between pulses.
- Soil drying – Prolonged gas injection may result in soil drying which may inhibit microbial activity.
- Injection gas composition – Greater concentrations of electron donor in nitrogen will promote increased perchlorate biodegradation but will result in greater costs. The composition used in this demonstration is based on the treatability studies.

- Electron donor injection volume – The injected electron donor volume must be sufficient to result in perchlorate biodegradation but should not be in great excess to minimize costs.