

FINAL REPORT

Perchlorate Destruction and Potable Water Production
Using Membrane Biofilm Reduction
and Membrane Filtration

ESTCP Project ER-200541

November 2013

Patrick Evans
Jennifer Smith
Tony Singh
Hoon Hyung
Clyde Arucan
Daniel Berokoff
CDM Smith

David Friese
Ryan Overstreet
Renato Vigo
APTwater

Bruce Rittman
Aura Ontiveros-Valencia
He-Ping Zhao
Youneng Tang
Bi-O Kim
Steven Van Ginkel
Rosa Krajmalnik-Brown
Arizona State University

This document has been cleared for public release



REPORT DOCUMENTATION PAGE

Form Approved
OMB No. 0704-0188

Public reporting burden for this collection of information is estimated to average 1 hour per response, including the time for reviewing instructions, searching existing data sources, gathering and maintaining the data needed, and completing and reviewing this collection of information. Send comments regarding this burden estimate or any other aspect of this collection of information, including suggestions for reducing this burden to Department of Defense, Washington Headquarters Services, Directorate for Information Operations and Reports (0704-0188), 1215 Jefferson Davis Highway, Suite 1204, Arlington, VA 22202-4302. Respondents should be aware that notwithstanding any other provision of law, no person shall be subject to any penalty for failing to comply with a collection of information if it does not display a currently valid OMB control number. **PLEASE DO NOT RETURN YOUR FORM TO THE ABOVE ADDRESS.**

1. REPORT DATE (DD-MM-YYYY) 18-11-2013		2. REPORT TYPE Final		3. DATES COVERED (From - To) Oct. 2005 - Nov.2013	
4. TITLE AND SUBTITLE Final Report: Nitrate and Perchlorate Destruction and Potable Water Production Using Membrane Biofilm Reduction				5a. CONTRACT NUMBER W912HQ-10C-0075	
				5b. GRANT NUMBER N/A	
				5c. PROGRAM ELEMENT NUMBER N/A	
6. AUTHOR(S) Evans, Patrick J.; Smith, Jennifer L.; Singh, Tony S.; Hoon, Huyng; Arucan, Clyde; Berokoff, Daniel; Friese, David; Overstreet, Ryan; Vigo, Renato; Rittmann, Bruce; Ontiveros-Valencia, Aura; Zhao, He-Ping; Tang, Youneng; Kim, Bi-O; Van Ginkel, Steven; and Krajmalnik-Brown, Rosa				5d. PROJECT NUMBER ER-200541	
				5e. TASK NUMBER N/A	
				5f. WORK UNIT NUMBER N/A	
7. PERFORMING ORGANIZATION NAME(S) AND ADDRESS(ES) CDM Smith Federal Programs Corporation Eva Opitz 1050 N Reed Station Rd STE D Carbondale, IL 62902-7305				8. PERFORMING ORGANIZATION REPORT NUMBER	
9. SPONSORING / MONITORING AGENCY NAME(S) AND ADDRESS(ES) Environmental Security Technology Certification Program Andrea Leeson 901 N Stuart St., Suite 303 Arlington, VA 22203				10. SPONSOR/MONITOR'S ACRONYM(S) ESTCP	
				11. SPONSOR/MONITOR'S REPORT NUMBER(S) N/A	
12. DISTRIBUTION / AVAILABILITY STATEMENT Distribution Statement A: Approved for Public Release, Distribution is Unlimited					
13. SUPPLEMENTARY NOTES None					
14. ABSTRACT This study demonstrated use of a membrane biofilm reactor (MBfR) for drinking water treatment from perchlorate- and nitrate- contaminated groundwater. The MBfR used anoxic autotrophic biodegradation for the complete destruction of perchlorate and nitrate. The objectives were to demonstrate the feasibility of MBfR to destroy perchlorate and nitrate in groundwater and produce potable water at the pilot scale, evaluate process control parameters to optimize performance, and estimate full-scale technology costs. These objectives were successfully demonstrated. The study included four phases: Start-Up, Optimization, Steady State, and a Challenge phase to assess system robustness and resiliency. Using indigenous organisms, the MBfR was colonized with perchlorate- and nitrate-reducing bacteria within approximately one month. Perchlorate was reduced by approximately 94 percent to 9.2±2.3 µg/L in the effluent of the lag reactor during Steady State. Total nitrogen (the sum of nitrate and nitrite) was reduced by approximately 99 percent to an average of 0.12±0.07 mg-N/L in the effluent of the lag reactor during Steady State.					
15. SUBJECT TERMS biodegradation, membrane, filtration, biofilm, potable, perchlorate, nitrate, drinking water treatment					
16. SECURITY CLASSIFICATION OF			17. LIMITATION OF ABSTRACT	18. NUMBER OF PAGES	19a. NAME OF RESPONSIBLE PERSON
a. REPORT	b. ABSTRACT	c. THIS PAGE			Dr. Patrick Evans
U	U	U	UU	384	19b. TELEPHONE NUMBER (include area code) 425-519-8300

TABLE OF CONTENTS

EXECUTIVE SUMMARY	x
Background and Technology Description	x
Performance Objectives and Results	xi
Costs	xiii
Implementation Issues	xiv
1.0 INTRODUCTION	1
1.1 Background	1
1.2 Objectives of the Demonstration	2
1.3 Regulatory Drivers	2
1.4 Stakeholder/End-User Issues	4
2.0 TECHNOLOGY	5
2.1 Technology Description	5
2.2 Technology Development	10
2.3 Advantages and Limitations of the Technology	13
3.0 PERFORMANCE OBJECTIVES	16
3.1 Summary	16
3.2 Treatment Effectiveness	17
3.3 Disinfection Effectiveness	18
3.4 Ability To Meet Drinking Water Treatment Primary And Secondary Mcls	19
3.5 Reliability	20
3.6 Safety	20
3.7 Permit Compliance	21
3.8 Regulatory Acceptance	21
4.0 SITE DESCRIPTION	22
4.1 Site Location and History	22
4.2 Site Geology/Hydrogeology	23
4.3 Contaminant Distribution	23
5.0 TEST DESIGN	25
5.1 Conceptual Experimental Design	25
5.2 Baseline Characterization	26
5.3 Treatability or Laboratory Study Results	26
5.4 Design and Layout of Technology Components	28
5.4.1 Process Equipment	33
5.4.2 Online Monitoring and Control	38
5.5 Field Testing	41
5.5.1 Installation and Start-Up	41
5.5.2 Optimization	44
5.5.3 Steady State	46
5.5.4 Challenge	47
5.5.5 Backwash Water Characterization	47
5.5.6 Demobilization	48
5.6 Sampling Methods	48

	5.6.1 Analytical/Testing Methods.....	48
	5.6.2 Sample Collection.....	49
5.7	Sampling Results	53
	5.7.1 Start-Up.....	53
	5.7.2 Optimization	57
	5.7.3 Steady State.....	65
	5.7.4 Challenge	73
6.0	PERFORMANCE ASSESSMENT	77
6.1	Treatment Effectiveness.....	77
	6.1.1 Perchlorate	77
	6.1.2 Nitrate and Nitrite	78
6.2	Disinfection Effectiveness	78
6.3	Ability to Meet Drinking Water Treatment Primary and Secondary MCLs	78
	6.3.1 Odor	78
	6.3.2 Turbidity	79
	6.3.3 DOC	79
	6.3.4 pH.....	79
6.4	Reliability.....	80
6.5	Safety	80
6.6	Permit Compliance.....	80
6.7	Regulatory Acceptance	81
7.0	COST ASSESSMENT.....	82
7.1	Cost Model.....	82
	7.1.1 Capital Cost Estimation	82
	7.1.2 Operational Costs.....	83
	7.1.3 MBfR System Design Basis.....	84
	7.1.4 Ion Exchange System Design Basis.....	88
7.2	Cost Drivers	89
7.3	Cost Analysis	89
	7.3.1 MBfR System.....	89
	7.3.2 IX System.....	92
	7.3.3 Comparison of the Technologies	93
8.0	IMPLEMENTATION ISSUES	96
8.1	Regulations and Permits	96
8.2	End-User Concerns	96
8.3	Procurement	97
9.0	REFERENCES	98

APPENDICES

- Appendix A: Points of Contact
- Appendix B: Field Logs
- Appendix C: Field Notes and Monitoring Data
- Appendix D: Field Methods

Appendix E: Quality Assurance and Quality Control
Appendix F: Laboratory Analytical Data
Appendix G: Online Monitoring Data
Appendix H: MBfR Demonstration at East Valley Water District
Appendix I: CDPH Letter of Conditional Acceptance

LIST OF TABLES

Table 2.1 Chronological Development of the MBfR Technology 11
Table 2.2 Technological Comparison for Perchlorate Removal..... 15
Table 3.1 Performance Objectives 16
Table 4.1 Historical Water Quality at Well 22 24
Table 5.1 Summary Statistics for Influent Water Quality at Well 22 throughout the
Demonstration from April 2011 to January 2012 26
Table 5.2 Gas Supply Equipment 34
Table 5.3 Sample Port Locations 38
Table 5.4 System Interlock Alarm Responses 39
Table 5.5 Phase I System Start-Up 42
Table 5.6 Phase II System Optimization Tests 44
Table 5.7 System Upset Conditions..... 46
Table 5.8 Phase IV System Challenge Tests 47
Table 5.9 Sample Collection Frequency 49
Table 5.10 Analytical Methods 51
Table 5.11 Comparison of Two-Stage and Single-Stage Operation..... 61
Table 5.12 Batch Test First-Order Rate Constants 64
Table 5.13 Steady State Operating Parameters 65
Table 5.14 Steady State Finished Water Disinfection Byproducts..... 71
Table 7.1 Cost Estimate Model..... 83
Table 7.2 Operations Cost Calculation Basis 83
Table 7.3 MBfR System Design Parameters 85
Table 7.4 MBfR System Configurations 88
Table 7.5 IX System Design Parameters 88
Table 7.6 MBfR Capital Costs..... 90
Table 7.7 MBfR Operation Cost..... 91
Table 7.8 MBfR Annual Project Cost..... 91
Table 7.9 IX Capital Cost 92
Table 7.10 IX Operational Cost 93
Table 7.11 IX Annual Project Cost..... 93

LIST OF FIGURES

Figure 2.1 Schematic of Hydrogen-Fed MBfR (a) Membrane Cross Section, (b) Woven Fibers and Biofilm, and (c) Membrane Module Design	5
Figure 2.2 Process Flow Diagram.....	8
Figure 4.1 Site Vicinity Map	22
Figure 4.2 Approximate Extent of Perchlorate Contamination	23
Figure 5.1 Experimental Design	25
Figure 5.2 MBfR Treatment System.....	29
Figure 5.3 MBfR Treatment System Arrangement.....	29
Figure 5.4 MBfR Treatment System Process Flow	30
Figure 5.5 MBfR Pilot Treatment Plant Piping and Instrumentation Diagram	31
Figure 5.6 MBfR Vessel System Piping and Instrumentation Diagram	32
Figure 5.7 MBfR Vessel Side-Reactors Prior to Installation (a) and After Installation (b)	36
Figure 5.8 OIT System Monitoring Screen for the Lag MBfR.....	38
Figure 5.9 Demonstration Schedule.....	41
Figure 5.10 Start-Up Perchlorate and Phosphate Dose (a) and Influent Flow Rate (b).....	54
Figure 5.11 Start-Up Total Nitrogen and Phosphate Dose (a) and Influent Flow Rate (b)	55
Figure 5.12 MBfR Lag Tracer Study	57
Figure 5.13 Autopsy of MBfR Reactor Modules.....	58
Figure 5.14 Optimization Perchlorate and Influent Flow (a) and Recycle Flow (b)	59
Figure 5.15 Optimization Total Nitrogen and Influent Flow (a) and Recycle Flow (b).....	60
Figure 5.16 Effect of Influent Flow Rate on Perchlorate Removal	62
Figure 5.17 Preliminary Batch Test for MBfR1 (a) and MBfR2 (b)	62
Figure 5.18 MBfR1 Batch Test with Varying Recycle Ratios	63
Figure 5.19 MBfR2 Batch Test with Varying Recycle Ratios	64
Figure 5.20 Effect of Sparge Frequency on Nitrate Performance	65
Figure 5.21 Steady State MBfR Perchlorate and Flow Rate (a) and Total Nitrate+Nitrite (b) ...	67
Figure 5.22 Steady State Stoichiometric Hydrogen Demand, Hydrogen for Membrane Fiber Flushing, and Excess Hydrogen.....	68
Figure 5.23 Steady State MBfR Lag Reactor Effluent Water Quality Bioindicators	69
Figure 5.24 Steady State Finished Water Quality Bioindicators (a), Sulfide, and Odor (b)	70
Figure 5.25 Steady State Treatment System DOC.....	71
Figure 5.26 Steady State Finished Water Turbidity.....	72
Figure 5.27 Steady State Media Filter Pressure Drop.....	73
Figure 5.28 Perchlorate and Total Nitrogen Concentrations at the Finished Water after a 4-Hour Shut-off of Hydrogen.....	75
Figure 5.29 Perchlorate and Total Nitrogen Concentrations at the Finished Water after a 24-Hour Shut-off of Hydrogen.....	75
Figure 5.30 Perchlorate and Total Nitrogen Concentrations at the Finished Water after a 4-Hour Shut-off of Power.....	76
Figure 5.31 Perchlorate and Total Nitrogen Concentrations at the Finished Water after a 24-Hour Shut-off of Power	76
Figure 7.1 3-D Rendering of Exemplary MBfR System	86
Figure 7.2 Process Flow Diagram of MBfR System	87
Figure 7.3 Comparison of MBfR 30-Year Amortized Capital and Operating Costs with IX and FXB operating at 1,000 gpm.....	95

ACRONYMS

A	specific surface area
ABS	acrylonitrile butadiene styrene
ANSI	American National Standards Institute
APHA	American Public Health Association
ASTM	American Society for Testing and Materials
ASU	Arizona State University
AWWA	American Water Works Association
As(V)	arsenate
BrO ₃ ⁻	bromate
C	concentration
C ₀	initial concentration, influent
CCL	Contaminant Candidate List
CCl ₃	chloroform
CCR	California Code of Regulations
CDPH	California Department of Public Health
CF	cubic feet
CFM	cubic feet per minute
CFU/mL	colony forming units per milliliter
cis-1,2 DCE	cis-1,2 dichloroethene
ClO ₄ ⁻	perchlorate
CO ₂	carbon dioxide
COC	chain of custody
Cr(VI)	chromate
CT	Concentration of disinfectant “C” multiplied by the contact time “T”
CTA	cellulose triacetate
DB	denitrifying bacteria
DBCP	dibromochloropropane
DBP	disinfection byproduct
DBP-FP	Disinfection byproduct formation potential
DO	dissolved oxygen
DOC	dissolved organic carbon
DoD	Department of Defense
DWEL	Drinking Water Equivalent Level
<i>E. coli</i>	<i>Escherichia coli</i>
EPS	Extracellular polymeric substances
ESTCP	Environmental Security Technology Certification Program
EVWD	East Valley Water District
FBRR	Filter Backwash Recycling Rule
ft bgs	feet below ground surface
FXB	fixed-bed bioreactor
GAC	granular activated carbon
g	grams
g H ₂ /m ² -day	grams of hydrogen per meter squared per day
gpm	gallons per minute

gpm/ft ²	gallons per minute per square foot
HAA	haloacetic acid
HMI	human machine interface
HPC	heterotrophic plate counts
IX	Ion Exchange
J	contaminant flux
LEL	lower explosive limit
LSI	Langelier Saturation Index
m ²	square meters
m ³	cubic meters
m ³ /d	cubic meters per day
MBfR	membrane biofilm reactor
MCL	Maximum Contaminant Level
MG	million gallons
mg/kg/d	milligrams per kilogram per day
mg/m ² /d	milligrams per square meter per day
mg-N/L	milligrams per liter as nitrogen
mg/L	milligrams per liter
mL	milliliters
MPN	most probable number
mS/cm	millisiemens per centimeter
mV	millivolts
NaCl	sodium chloride
NO ₃ ⁻	nitrate
NO ₂ ⁻	nitrite
NDEA	N-nitrosodiethylamine
NDMA	N-nitrosodimethylamine
NDBA	N-nitrosodi-n-propylamine
NDPA	N-nitroso-di-n-propylamine
ng/L	nanograms per liter
NPDWR	National Primary Drinking Water Regulation
NSDWR	National Secondary Drinking Water Regulations
NTU	nephelometric turbidity units
OH ⁻	hydroxide ion
OIT	operator interface terminal
ORP	oxidation-reduction potential
P&ID	pipng and instrumentation diagram
PLC	Programmable Logic Controller
PRB	perchlorate-reducing bacteria
psi	pounds per square inch
psig	pounds per square inch gauge
Q	volumetric flow rate
QA/QC	Quality Assurance/Quality Control
QAPP	Quality Assurance Project Plan
qPCR	quantitative polymerase chain reaction
RASP	Rialto Ammunition Storage Point

RWQCB	Regional Water Quality Control Board
SCFH	standard cubic feet per hour
SCFM	standard cubic feet per minute
SCADA	supervisory control and data acquisition
SDWA	Safe Drinking Water Act
Se(VI)	selenate
SRB	sulfate reducing bacteria
SU	standard units
SWTR	Surface Water Treatment Rule
TCA	trichloroethane
TCE	trichloroethene
TCR	Total Coliform Rule
TDS	total dissolved solids
THM	trihalomethane
THM-FP	trihalomethane formation potential
TON	threshold odor number
TSS	total suspended solids
TT	treatment technique
UCMR	Unregulated Contaminant Monitoring Rule
U.S.	United States
USEPA	United States Environmental Protection Agency
V	volume
VC	vinyl chloride
VFD	variable frequency drive
VOC	volatile organic compound
WCLC	West Coast Loading Corporation
WEF	Water Environment Federation
WVWD	West Valley Water District
µg/L	micrograms per liter
µm	micrometers
µS/cm	microsiemens per centimeter

Acknowledgements

This project was funded by the Environmental Security Technology Certification Program (ESTCP). We are very appreciative of the support and encouragement from Dr. Andrea Leeson. The project wishes to thank and recognize the support provided by Tom Crowley of West Valley Water District (WVWD) and Ron Buchwald of East Valley Water District, (EVWD) who granted access to the Demonstration sites. The project team wishes to thank Sean McCarthy, Eugene Leung with the California Department of Public Health (DPH) and Heather Collins formerly with DPH for their interest and support in the project. Contact information for individuals involved in this project is provided in Appendix A.

EXECUTIVE SUMMARY

BACKGROUND AND TECHNOLOGY DESCRIPTION

Perchlorate (ClO_4^-) is a human health concern because it can prevent assimilation of iodide in the thyroid by competitively inhibiting its uptake. Iodide regulates normal functions of the thyroid and is critical in the growth and development of fetuses, infants, and children (USEPA 2005). As of February 2011, the United States Environmental Protection Agency (USEPA) determined that perchlorate can be regulated under the Safe Drinking Water Act (SDWA), and in October 2007, California Department of Public Health (CDPH) established a maximum contaminant level (MCL) of 6 micrograms per liter ($\mu\text{g/L}$). Nitrate is a co-contaminant in water with perchlorate because ammonium nitrate is a main component in rocket fuel and explosives (Wang et al. 2002). In addition, nitrate is often found in groundwater because of agricultural impacts. Nitrate (NO_3^-) is regulated by the SDWA and has an MCL of 10 milligrams per liter as nitrogen (mg-N/L).

While ion-exchange (IX) resins are currently used for perchlorate treatment, they are costly and do not destroy contaminant mass. By contrast, membranes are increasingly used in the drinking water industry for full-scale potable water treatment. The membrane biofilm reactor (MBfR) process demonstrated in this project used the latest advances in membrane technologies and included anoxic biological reduction using a staged hydrogen-fed membrane biofilm reactor, aerobic biological stabilization, media filtration, and disinfection. This technology builds upon a number of previously successful MBfR studies treating perchlorate and nitrate in groundwater. The MBfR uses anoxic biodegradation for the complete destruction of perchlorate, and it may be used for nitrate removal. The reactor is comprised of numerous permeable hollow-fiber gas-transfer membranes that are pressurized with hydrogen gas. Hollow fiber membranes are widely used in a range of industries for bubble-less gas transfer. The MBfR is an adaptation of this proven approach for perchlorate and nitrate treatment. Bubble-less gas transfer allows delivery of hydrogen gas directly to the bacteria. This results in nearly 100 percent hydrogen usage, which makes the process economical (no donor waste) and safe. A biofilm containing a community of perchlorate-reducing, nitrate-reducing, and other bacteria grow on the exterior surface of the hollow fibers. Hydrogen serves as the electron donor that also minimizes biomass generation. This process results in reduction of perchlorate and nitrate and can also be used for a range of other oxidized contaminants including trichloroethene (TCE), chromate, selenate, and bromate (Nerenberg and Rittmann 2004; Rittmann et al. 2004; Adham et al. 2005; Chung et al. 2006b; Chung et al. 2006c; Chung et al. 2006d).

The purpose of this Demonstration was to evaluate the feasibility of MBfR to destroy perchlorate and nitrate in groundwater and produce potable water at the pilot scale, evaluate process control parameters to optimize performance, and estimate full-scale technology costs. This pilot-scale treatment system was installed at West Valley Water District (WVWD) in Rialto, California. The treatment train consisted of two 575-gallon MBfR vessels, in a two-stage lead/ lag configuration, containing seven polypropylene-fiber membrane modules in each tank. The 14 modules had a total membrane surface area of 2,000 square meters (m^2). Groundwater was pumped into the lead MBfR vessel. The effluent from the lead vessel then flowed into the lag MBfR vessel. Recirculation pumps with an adjustable flow rate of 70 to 280 gpm were used for recirculating water through the membrane modules in each MBfR vessel. The MBfR lag vessel effluent was

subsequently processed by aeration, media filtration, and disinfection. Indigenous microorganisms attached to the membrane exterior surfaces and created a biofilm. Electron donor (hydrogen gas) and nutrients (phosphoric acid) were supplemented to the reactors. The attached microorganisms preferentially reduced dissolved oxygen (DO), nitrate, perchlorate, and sulfate. Additional processing prior to groundwater re-injection included filtration through granular activated carbon (GAC) and ion exchange resin to meet California Regional Water Quality Control Board permit requirements for discharge to groundwater. The study included four phases: Start-Up, Optimization, Steady State, and a Challenge Phase. The Challenge phase included intentional process upsets to assess resiliency and reliability of the technology. A parallel and important laboratory investigation of the MBfR performance was also conducted at Arizona State University. This research is briefly summarized in this report and fully documented in a separate report (Rittmann et al. 2013).

PERFORMANCE OBJECTIVES AND RESULTS

Perchlorate

Perchlorate was reduced from an average of 154 ± 5 $\mu\text{g/L}$ to an average of 9.2 ± 2.3 $\mu\text{g/L}$ in the effluent of the lag reactor during Steady State (94.4 percent reduction). While the treatment objective of 6 $\mu\text{g/L}$ was not met, perchlorate was consistently removed with little variation (coefficient of variation was 0.75%).

During Optimization, influent flow rate and recycle flow rate were observed to affect perchlorate treatment efficacy, as discussed in detail in Section 5.7.2. The effect of influent flow rate and associated electron acceptor loading was evaluated for flows rates of 10, 15, and 20 gpm. Perchlorate was on average 8.5 $\mu\text{g/L}$ while operating at 10 gpm, 17.9 $\mu\text{g/L}$ at 15 gpm, and 27 $\mu\text{g/L}$ at 20 gpm. Recycle flow rates were tested further during batch tests, where four recycle flow rates were tested in each MBfR vessel. In general, the best performance was observed when recycle flow rates were increased indicating mass transfer limitations. However, operation at the highest recycle rates did not promote complete perchlorate removal. Other factors including an overabundance of sulfate-reducing bacteria relative to perchlorate reducing bacteria limited complete perchlorate reduction (Rittmann et al. 2013). Finally, the impact of sparge frequency and gas type was evaluated. Sparging was conducted to remove buildup of biomass and inert compounds in the membranes. Use of compressed air rather than nitrogen for sparging resulted in no measurable change in performance. Compressed air is less expensive than nitrogen and may be used to decrease operational costs. Sparging frequencies of 24 hours or less did not change perchlorate or nitrate removal appreciably; 12 hours was selected for Steady State operations.

Batch tests demonstrated that complete perchlorate removal was possible but was observed to occur when sulfate reduction and sulfide generation began. Modeling and bench-scale studies by ASU demonstrated that complete perchlorate removal was observed without sulfide production if removal flux of nitrate and oxygen – expressed as stoichiometric hydrogen demand – was about 0.18 grams of hydrogen per meter squared per day ($\text{g H}_2/\text{m}^2\text{-day}$) (Rittmann et al. 2013). Operation under these conditions in the laboratory prevented overgrowth of sulfate reducing bacteria. However, single-stage operation of the pilot-scale system at a removal flux of nitrate

and oxygen of $0.12 \text{ g-H}_2/\text{m}^2\text{-d}$ did not prevent overgrowth of sulfate reducing bacteria and promote complete perchlorate reduction. Therefore, other differences between the laboratory and pilot-scale systems such as trans-membrane liquid velocity and associated mass-transfer resistance may have prevented complete perchlorate reduction.

Nitrate

The MBfR was highly effective at removing nitrate. Total nitrogen (the sum of nitrate and nitrite) was reduced from an influent average of 9.0 mg-N/L to an average of $0.12 \pm 0.07 \text{ mg-N/L}$ in the effluent of the lag reactor during Steady State (98.3 percent reduction). Nitrate reduction was consistently removed with little variation (coefficient of variation was 0.94%) with the highest effluent total nitrate as 0.24 mg-N/L . Similar to perchlorate, factors controlling performance were influent flow rate and recycle flow rate. Reductions of nitrate to less than 0.5 mg-N/L were demonstrated at a flow as high as 18 gpm . Highest reductions were observed when recycle flow rates were highest. Another key finding was that 79 percent of nitrate was reduced across the lead reactor with an average lead effluent concentration of $1.8 \pm 0.16 \text{ mg-N/L}$ during Steady State. As such, a full-scale system may include single-stage operations, thus decreasing capital and operational costs and system footprint.

Drinking Water Treatment Goals

Other drinking water treatment goals that were evaluated during the Demonstration included disinfection, odor, turbidity, dissolved organic carbon (DOC), and pH. Disinfection was accomplished using sodium hypochlorite with a free chlorine residual of 0.2 mg/L to meet disinfection requirements based on CT. CT stands for the concentration of disinfectant “C” multiplied by the contact time “T” in minutes. Fecal coliforms, total coliforms, *Escherichia coli* (*E. coli*) and heterotrophic plate counts (HPCs) were used as indicator parameters for disinfection performance. During Steady State *E. coli*, fecal coliforms, and total coliforms were below the detection limit ($2/100 \text{ mL}$) in all post-disinfection samples. HPCs were on average 43 most probable number per milliliter (MPN/mL), and no samples were greater than the MCL of 500 MPN/mL . Disinfection byproducts were below regulatory limits. Haloacetic acids (HAA5) were below detection ($< 6 \text{ } \mu\text{g/L}$) and total trihalomethanes (TTHMs) averaged $4.8 \text{ } \mu\text{g/L}$ compared to the MCL of $80 \text{ } \mu\text{g/L}$. Nitrosamines were not detected.

Odorous compounds, primarily hydrogen sulfide, can be inadvertently generated if conditions become more strongly reducing than targeted. The performance objective for odor was less than the US EPA National Primary Drinking Water Regulation’s secondary standard for threshold odor number (TON) of three. The average TON during Steady State was 2.2.

Turbidity is also of concern since this technology involves growing a biofilm that can detach from membrane surfaces. Media filtration in combination with a coagulant filter aid was employed down-stream of the MBfR process. An average turbidity of 0.27 nephelometric turbidity units (NTU) was observed at the filter effluent during Steady State. The media filter was backwashed approximately every 12 hours, which resulted in wasting approximately 3 percent of the system influent water. Media filter backwash water was analyzed for TSS to

estimate solids generated for disposal. Based on these samples, approximately 10,000 grams (22 pounds) of solids were generated per MG of water treated from media filter backwashing.

Residual biodegradable organic compounds in treated water can decrease water biostability and promote regrowth of organisms in distribution systems. DOC was selected as a surrogate indicator for biological stability. The increase in DOC from the system influent to the finished water was on average 0.4 milligrams per liter (mg/L) during Steady State. While the goal for this project was less than a 0.2 mg/L increase, the metric is not driven by regulation, and requirements for biological stability are specific to each drinking water distribution system. This increase of 0.4 mg/L DOC is not necessarily biodegradable and may be stable in some distribution systems.

Control of pH was important for this system, since denitrification and other reduction processes can result in increased alkalinity. During the MBfR Demonstration, the pH of the finished water remained within the secondary MCL of between 6.5 and 8.5 standard units (SU). The average finished water pH was 7.8 ± 0.2 SU during the one-month Steady State period.

COSTS

The cost assessment was conducted for an MBfR treating nitrate and not perchlorate because the 6- $\mu\text{g/L}$ performance objective for perchlorate removal was not achieved. The cost model used water quality conditions at the site, located at Well 22 in Rialto, California. The model assumed full-scale operations were at 1,000 gpm with six different operating scenarios. Three nitrate treatment goals were selected for a 1,000 gpm full-scale MBfR system: 1) 28 mg-N/L of influent and 4.0 mg N/L effluent, 2) 10 mg N/L of influent and 6.8 mg N/L effluent, and 3) 18 mg N/L of influent and 6.8 mg N/L of effluent. Scenario 1 has similar design conditions to previously published work (Brown et al. 2008; Webster and Togna 2009) and was included in this study for comparison. The three treatment goals were applied to two MBfR system designs: a design using the same process used in the Demonstration (Scenario 1, 2 and 3) and a design modified and improved based on information gathered during the Demonstration (Scenario 4, 5 and 6). The modified design includes several enhancements to increase system efficiency and decrease wastewater generation. Unit total costs including operations, maintenance, and amortized capital for the various scenarios were expressed in terms of MG of water treated as follows:

Scenario	Purpose	Cost (\$/MG treated)
1	Comparable to previous research studies	706
2	Represents conditions similar to this Demonstration	863
3	An example system with higher nitrate concentrations	2,037
4	Comparable to scenario 1, but with a revised treatment process integrating key lessons from the Demonstration	582
5	Comparable to scenario 2, but with a revised treatment process integrating key lessons from the Demonstration	640
6	Comparable to scenario 3, but with a revised treatment process integrating key lessons from the Demonstration	1,290

Note: MG – million gallons

Comparison between the MBfR system and IX showed that the MBfR was more economical, particularly when wastewater disposal for IX regeneration is included. IX resin regeneration disposal costs are largely site-specific. Wastewater from the MBfR system, which includes media backwash water and MBfR sparging water, can be discharged through the municipal sanitary sewer after removing some suspended solids. However, wastewater generated during IX regeneration cannot be directly discharged to a municipal sewer mainly because of the high salt concentrations. The unit operations, maintenance, and amortized capital costs for IX were estimated to be \$2,781/MG water treated for Scenario 1, \$2,787/MG for Scenario 2 and \$3,462/MG for Scenario 3. MBfR costs were also compared with the ESTCP project “Direct Fixed-Bed (FXB) Biological Perchlorate Destruction Demonstration” (Brown et al. 2008). The unit cost of the FXB system was \$730/MG, which is similar to the MBfR unit cost of \$706/MG for Scenario 1. However, MBfR costs are lower when compared with the modified design - the cost for Scenario 4 was approximately 30% lower at \$528/MG. The MBfR was shown to be competitive with other biological treatment technologies for nitrate removal.

IMPLEMENTATION ISSUES

The results of this Demonstration study showed that: 1) the MBfR bioreactor treatment system provided consistent and robust nitrate removal; 2) the reactor provided reductions in perchlorate over 90 percent, but did not meet the treatment objective of less than 6 µg/L; 3) aeration, media filtration, and disinfection provide effective post-treatment; 4) system operation is straightforward, requiring no specialized training; 5) the indigenous bacterial communities formed a biofilm within approximately one month; and 6) total water production costs are lower than conventional IX treatment. While there are currently no Federal regulations for perchlorate in place, the USEPA has established an Interim Drinking Water Health Advisory of 15 µg/L. The CDPH has developed rules that are more stringent and established a State MCL of 6 µg/L as of October 2007. The MCL for nitrate is 10 mg-N/L. All applicable Federal and State regulations and requirements for drinking water treatment must be met for a full-scale MBfR system. In addition to meeting primary and secondary drinking water treatment regulations, regulatory acceptance, permitting, and safety are important implementation issues. A major end-user concern with this system is use of hydrogen, a flammable gas. The data presented herein demonstrated that this issue was easily managed and did not necessitate extraordinary efforts. The following observations and actions were part of this Demonstration:

- Hydrogen was supplied using an on-site generation system with back-up cylinders. The cylinders were on a gas-supply pad that stabilized and manifolded the gases together.
- Flammable gas/no-smoking placards were used at the site.
- Lower explosive limit (LEL) sensors stopped the system when hydrogen was detected.
- Liquid nitrogen was supplied in a commercially available dewar. From a cold surface hazard perspective, liquid nitrogen is handled as liquid oxygen is at commercial facilities.
- Liquid carbon dioxide was supplied in cylinders similar to hydrogen back-up cylinders. These were secured in the same containment area as hydrogen and nitrogen.

Conditional acceptance of the MBfR has been obtained from CDPH. The first full-scale MBfR system for treatment of nitrate in drinking water is in the process of being permitted at Cucamonga Valley Water District. The combination of data from this Demonstration project in

conjunction with regulatory acceptance of a full-scale system will support additional work and willingness to design and operate this technology full-scale.

1.0 INTRODUCTION

1.1 BACKGROUND

Perchlorate is a strong oxidizer that is primarily used in solid rocket fuels, fireworks, explosives, and road flares. While perchlorate can generate from natural processes, the majority of occurrence in the United States (U.S.) is from anthropogenic sources. Perchlorate is a human health concern because it can prevent assimilation of iodide in the thyroid by competitively inhibiting its uptake. Iodide regulates normal functions of the thyroid and is critical in the growth and development of fetuses, infants, and children (USEPA 2005). As of February 2011, the U.S. Environmental Protection Agency (USEPA) determined that perchlorate can be regulated under the Safe Drinking Water Act (SDWA). EPA then began the process of determining and proposing a National Primary Drinking Water Regulation (NPDWR) for perchlorate to establish a national primary maximum contaminant level (MCL) in drinking water (Lehman and Subramani 2011).

Perchlorate is present in many potable water supplies throughout the U.S. (Wang et al. 2002), with the highest density of contamination in Southern California, west central Texas, and New Jersey, New York, and Massachusetts (Lehman and Subramani 2011). From 2001 to 2005, USEPA required sampling for perchlorate in potable water supplies that serve more than 10,000 customers under the Unregulated Contaminant Monitoring Rule 1 (UCMR1). Of the 3,865 drinking water systems that were sampled, perchlorate was detected in 647 samples from 25 states, which represented 160 systems (Brandhuber et al. 2009). The frequency of perchlorate detection in these systems was approximately 4.1 percent (GAO 2010). Many but not all of the anthropogenic sources of perchlorate were attributable to Department of Defense (DoD) and DoD-contractor operations.

Nitrate (NO_3^-) is commonly found as a co-contaminant in water with perchlorate because ammonium nitrate is a main component in rocket fuel and explosives (Wang et al. 2002). Nitrate is regulated by the SDWA and has an MCL of 10 mg-N/L. Costs for mitigating perchlorate and nitrate contamination can be significant; thus, demonstration and validation of cost-effective treatment technologies is critical to the DoD.

Anoxic biodegradation can be used to treat perchlorate and nitrate, and it can result in complete elimination of the contaminants. The anoxic autotrophic membrane biofilm reactor (MBfR) may be used for biologically mediated perchlorate and nitrate reductions. Autotrophic bacteria do not use organic carbon as a source for growth; instead, they grow using bicarbonate as a carbon source. Since most groundwater is oligotrophic (i.e., low organic carbon), autotrophic hydrogen-oxidizing bacteria would be indigenous and favored under conditions promoted in the MBfR. The reactor is comprised of numerous permeable hollow fiber gas-transfer membranes that are pressurized with hydrogen gas. The membranes are woven together into a permeable sheet. Water is pumped through the reactor and contacts the outside of the fiber membranes. Hydrogen is pumped through the interior of the fibers, and a biofilm containing a community of indigenous perchlorate- and nitrate-reducing bacteria grow on the exterior surface of the hollow fibers. These bacteria are ubiquitous in the environment (Urbansky 1998). Hydrogen serves as the electron donor for biological denitrification of nitrate to elemental nitrogen and for reduction of

perchlorate to chloride ions. Use of hydrogen for autotrophic biodegradation is ideal because hydrogen has a low biomass yield, relatively low cost (13 to 15 times less than common organic amendments), is relatively insoluble in water, and does not persist in treated water, thereby preventing further microbial growth caused by excess donor (Rittmann and Snoeyink 1984; Nerenberg et al. 2002).

The purpose of this Demonstration was to validate the feasibility of the MBfR for anoxic biodegradation of perchlorate and nitrate. A pilot-scale drinking water treatment plant using the MBfR technology was installed at the WVWD Well 22 facility in Rialto, California. The treatment train included perchlorate and nitrate removal using two MBfRs in series. Additional downstream processing included stabilization of the MBfR effluent to remove DOC via aerobic biological filtration. An aeration tank was used to increase DO concentration and oxidation-reduction potential (ORP) prior to filtration. The media filtration and a coagulant filter aid were used to remove suspended solids and turbidity. Water was subsequently disinfected using chlorination. Post process treatment was required by the California Regional Water Quality Control Board prior to discharge back to groundwater and included granular activated carbon (GAC) filtration and ion exchange (IX). GAC was used for removal of chlorinated solvents present as a co-contaminant in the source water. IX was used for removing residual perchlorate prior to injection back to groundwater.

1.2 OBJECTIVES OF THE DEMONSTRATION

The purpose of this Demonstration was to evaluate the feasibility of the MBfR to destroy perchlorate and nitrate in groundwater and produce potable water at the pilot scale, evaluate process control parameters to optimize performance, and estimate full-scale technology costs. Additional objectives were to obtain regulatory acceptance of the technology, conduct a safe Demonstration, and have no permit violations.

Specific advantages of the technology include perchlorate and nitrate destruction, minimization of DOC in the effluent, and minimization of TSS and bacteria in the produced water. The project was organized into four phases: Start-Up, Optimization, Steady State, and a Challenge phase. Groundwater was pumped from a well to an equalization tank, and then to the MBfR at flow rates as high as 22 gpm. The Start-Up phase was designed to promote growth of perchlorate- and nitrate-reducing bacteria on the hollow fiber membranes. During Optimization, operational conditions were varied to evaluate system performance with respect to contaminant removal and operating and maintenance requirements. A period of Steady State operation assessed process stability, which is critical for potable water production. The Challenge phase included intentional process upsets to assess resiliency and reliability of the technology, such as influent flow shutdown and discontinuation of electron donor delivery.

1.3 REGULATORY DRIVERS

Widespread contamination of groundwater with perchlorate was not discovered in the U.S. until 1997. During that year, the CDPH adopted a provisional action level of 18 µg/L based on limited toxicological data, but there was no analytical method that was sensitive to this concentration. Later that year, a new analytical method was developed that was more sensitive with a detection

limit of 4 µg/L (Hatzinger 2005; USEPA 1998). EPA added perchlorate to the Contaminant Candidate List (CCL) in 1998. This list encompasses contaminants that are being considered for regulation under the Safe Drinking Water Act (SDWA). From 2001 to 2005, the USEPA required drinking water utilities to monitor for perchlorate and report results under Unregulated Contaminant Monitoring Rule 1 (UCMR1). In February 2005, EPA set the official reference dose for perchlorate as 0.0007 milligrams per kilogram per day (mg/kg/d), a drinking water equivalent level (DWEL) of 24.5 µg/L based on the monitoring results and results from additional toxicological investigations from the National Research Council of the National Academy of Sciences (Lehman and Subramani 2011). USEPA has since established an Interim Drinking Water Health Advisory of 15 µg/L. In the absence of formal federal regulatory guidance, several states began regulating perchlorate in drinking water. In 2006 Massachusetts established an MCL of 2 µg/L, in October 2007 California established an MCL of 6 µg/L, and in 2009 New Jersey established an MCL of 5 µg/L (Lehman and Subramani 2011). Perchlorate is also governed under the California's guidance document for the use of extremely impaired sources when the concentration exceeds 10 times the MCL (60 µg/L), the source water "is extremely threatened with contamination due to proximity to known contaminating activities", "contains a mixture of contaminants of health concern", or "is designed to intercept known contaminants of health concern" (CDPH 1997). In February 2011, EPA released the determination that perchlorate met the SDWA criteria for regulation, and EPA is currently in the process of establishing an MCL (Lehman and Subramani 2011). Nitrate is regulated by the SDWA and has an established MCL of 10 (mg-N/L).

In addition to meeting regulatory requirements for perchlorate and nitrate, groundwater that is used as a drinking water source needs to comply with all applicable regulations under EPA's SDWA. This includes relevant regulations such as the Total Coliform Rule (TCR), the Interim, Long Term 1, and Long Term 2 Enhanced Surface Water Treatment Rules (SWTR), the UCMR 1, Filter Backwash Recycling Rule (FBRR), the Stage 1 and Stage 2 Disinfection Byproduct (DBP) Rules, the Groundwater Rule, and the Lead and Copper Rule. Several states have their own regulations that are more stringent than the SDWA. The CDPH is responsible for certifying drinking water treatment technologies pursuant to California Health and Safety Code Section 116830. The CDPH is also responsible for permitting drinking water supplies. The California Code of Regulations (CCR), Title 22 (Social Security), Division 4 (Environmental Health) specifies requirements for potable water that are analogous to the SDWA. Accordingly, specific treatment requirements for potable water production in addition to perchlorate and nitrate removal include but are not limited to:

- Compliance with primary drinking water standards for nitrite.
- Filtration to remove suspended solids and bacteria.
- Disinfection to ensure that the potable water supply does not contain pathogenic bacteria (e.g., *E. coli*, fecal coliforms, and total coliforms) or elevated levels of heterotrophic bacteria.

DBP formation is measured by monitoring for trihalomethanes (THMs) and haloacetic acids (HAAs) at the effluent of the finished water. Currently, the USEPA and the State of California have established MCLs of 0.08 mg/L and 0.06 mg/L for THMs and HAAs, respectively. Additional analysis for DBP formation potential (DBP-FP) and nitrosamines were monitored

during steady state and the Challenge phase per request by the CDPH. California considers N-nitrosodimethylamine (NDMA) and other nitrosamines as emerging contaminants and consequently has not issued an MCL. However, the State of California issued a Notification Level of 10 nanograms per liter (ng/L) for three nitrosamines: N-nitrosodiethylamine (NDEA), NDMA, and N-nitrosodi-n-propylamine (NDBA). Response levels are concentrations where CDPH recommends removing the source from service, as water quality levels correspond to a 10^{-4} risk level for cancer. Response Levels of 100, 300, and 500 ng/L are set by CDPH for NDEA, NDMA, and NDBA, respectively. The USEPA has not specified an MCL for nitrosamines.

1.4 STAKEHOLDER/END-USER ISSUES

Potential stakeholders and end-users for the technology include DoD Remedial Project Managers, DoD contractors, private and public water utilities, and regulatory agencies including the CDPH. The general public is an important end-user since they will consume potable water produced by a permitted full-scale system. These stakeholders and end-users may use or evaluate the technology for potable water production from groundwater contaminated with perchlorate and nitrate. This technology may also be used for non-potable water treatment, as in remediation of contaminated groundwater. The technology may also be applicable to reduction of other oxidized contaminants including trichloroethene, chromium VI, selenate, and others (Chung et al. 2006b; Chung and Rittmann 2007; Chung et al. 2007; Rittmann et al. 2004).

This Demonstration answered several questions about MBfR for perchlorate and nitrate reduction, including:

- Is the process robust to potential process upsets?
- What are the treatment costs?
- How does the technology perform under various operating conditions?
- What are the key design parameters for technology optimization?
- What is the likelihood for regulatory acceptance of the technology?

2.0 TECHNOLOGY

2.1 TECHNOLOGY DESCRIPTION

The MBfR process is based on the latest advances in membrane technology and includes anoxic biological reduction using a staged hydrogen-fed membrane biofilm reactor followed by aerobic biological stabilization, media filtration, and disinfection (Figure 2.1). This technology builds upon a number of previously successful MBfR studies treating high concentrations of perchlorate and nitrate in groundwater. The MBfR design uses permeable hollow-fiber membranes pressurized with hydrogen gas (H_2). Hydrogen is fed to the lumen of hollow-fiber gas-transfer membranes, and bacteria grow naturally as a biofilm on the exterior of the membranes exposed to contaminated water. Membrane sheets of woven hollow-fiber filaments are wrapped around an interior perforated core, and water flows out radially (Figure 2.1c). Hollow fiber membranes are widely used in a range of industries for bubble-less gas transfer. Bubble-less gas transfer allows delivery of hydrogen gas directly to the bacteria. This results in nearly 100 percent hydrogen usage, which makes the process economical (no donor waste) and safe.

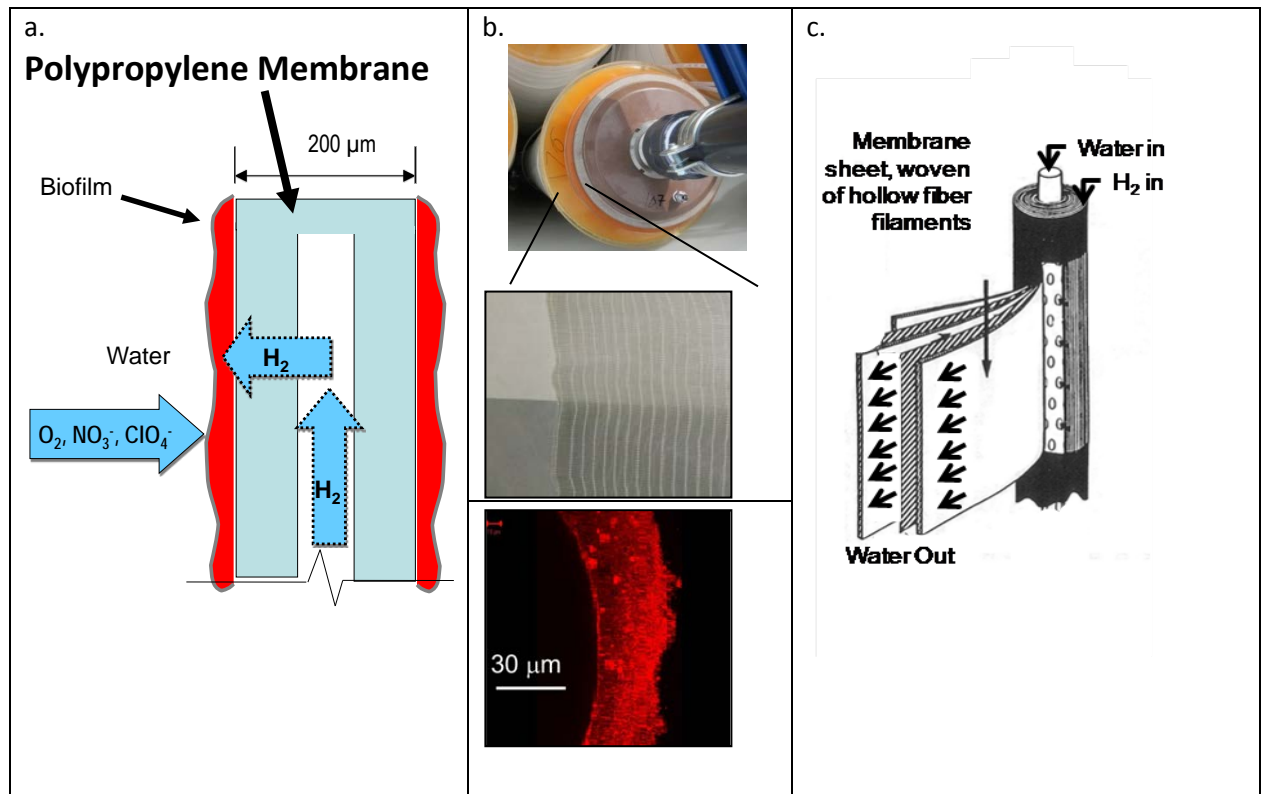
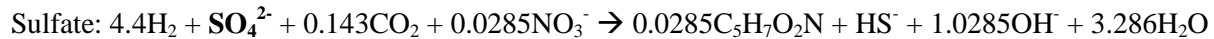
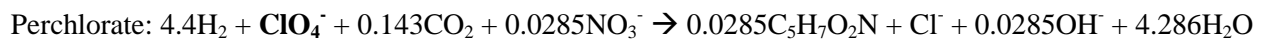
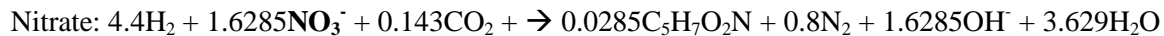
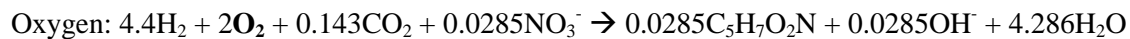

Figure 2.1 Schematic of Hydrogen-Fed MBfR (a) Membrane Cross Section, (b) Woven Fibers and Biofilm, and (c) Membrane Module Design

The treatment process for the Demonstration consisted of two 575-gallon MBfR vessels, in a two-stage lead/lag configuration containing seven polypropylene-fiber membrane modules in each tank. The 14 modules had a total membrane surface area of $2,000 \text{ m}^2$. Influent water was fed into the lead MBfR vessel. The lead vessel effluent then flowed into the lag MBfR vessel. Recirculation pumps with an adjustable flow rate of 70 to 280 gpm were used for recirculating

water through the membrane modules in each MBfR vessel. The MBfR lag vessel effluent was subsequently processed by aeration, media filtration, and disinfection. Indigenous microorganisms from the feed water attached on to the membrane surface and created a biofilm. Adequate quantities of electron donor (hydrogen gas) and nutrients (phosphoric acid) were added to the reactors. The attached microorganisms preferentially consumed DO, nitrate, and perchlorate. As such, the biofilm contained aerobic, nitrate-reducing, and perchlorate-reducing bacteria. Sulfate can also be reduced to sulfide provided sufficient hydrogen gas is delivered.

The biological process was staged to minimize reactor volume and control growth. The goal was to achieve an increased volumetric loading by taking advantage of the well-known plug-flow effect from using reactors in series. Reactors in series allow treatment of higher substrate concentrations in the first stage, with a low concentration in the lag reactor to act as a polishing process and meet low-level effluent standards. The first stage was used to remove DO, nitrate, and some perchlorate. The second stage was used to remove the remainder of the perchlorate. The two vessels alternated positions between lead and lag periodically to sustain similar biological growth between the two vessels. Carbon dioxide (CO₂) was used for pH control to prevent precipitation of hardness. The denitrification process produces alkalinity, which increases the pH. Carbon dioxide was added to lower the pH back to near neutral, with a set point of 7.2 standard units (SU). Carbon dioxide was also used as a carbon source for microbial assimilation. The stoichiometric relationships between hydrogen, carbon dioxide, and electron donor with cell mass production (C₅H₇O₂N), alkalinity produced (hydroxide ion, OH⁻), and other byproducts for different electron acceptors were developed assuming 0.091 as the fraction of electrons going to assimilate biomass per electron from hydrogen (Rittmann and McCarty 2001), as follows:



The low biomass yield of 0.0285 mole of C₅H₇O₂N per mole NO₃⁻ translates into a slow growth rate for autotrophs (Lee and Rittmann 2002) and thus fewer operational controls needed for biomass control and lower solids handling.

Post Treatment: For drinking water treatment applications, post-MBfR processes need to achieve the following water quality goals:

- **Water stability:** since biological nitrate and perchlorate reduction requires anoxic conditions, water must be re-aerated during the post-treatment process. Oxygenation also removes taste and odor-causing compounds (e.g. sulfide).
- **Turbidity:** to meet SWTR requirements.
- **Wastewater solids management:** solids generated from sparging the MBfR and media filter backwashing must be disposed of using an appropriate method.
- **Disinfection:** as with any drinking water treatment process, a disinfection step must be included to minimize the potential for bacteria regrowth and meet CT requirements.
- **Disinfection Byproduct Formation:** DBPs must be below their respective MCLs.

The treatment processes implemented downstream of the MBfR included aeration, media filtration, and disinfection. Additional processing prior to groundwater re-injection included filtration through GAC and IX resin to meet California Regional Water Quality Control Board permit requirements. The process flow diagram is provided in Figure 2.2.

The first step after MBfR treatment was aeration to replenish DO. After aeration, water passed through a media filter where solids and DOC were removed. A coagulant, or filter aid, was added prior to the media filter. This chemical addition allowed for more efficient suspended solids removal by the filter. The effluent from the media filter was pumped to the finished water where sodium hypochlorite was added for disinfection. This water was discharged to the sump tank. Water from the sump tank was fed through two bag filters operated in parallel for solids removal prior to two GAC vessels operated in series. The GAC vessels removed volatile organic compounds that were present as co-contaminants. For complete removal of perchlorate before re-injection to groundwater, the GAC effluent was conveyed through two IX vessels in series. A back flush/effluent tank system capable of storing media filter backwash water was also part of the system. Key design criteria for the MBfR included:

- Membrane surface area
- Membrane packing density
- Number of reactor stages
- Hydraulic residence time in each stage
- Influent flow rate and electron acceptor loading
- MBfR water recirculation flow rate
- Hydrogen gas pressure
- Hydrogen consumption rate
- Sparge frequency
- Sparge gas composition

Key design criteria for the media filter system included:

- Coagulant/filter aid type and dose
- Filter surface loading rate
- Filter media type(s) and depth(s)
- Backwash frequency

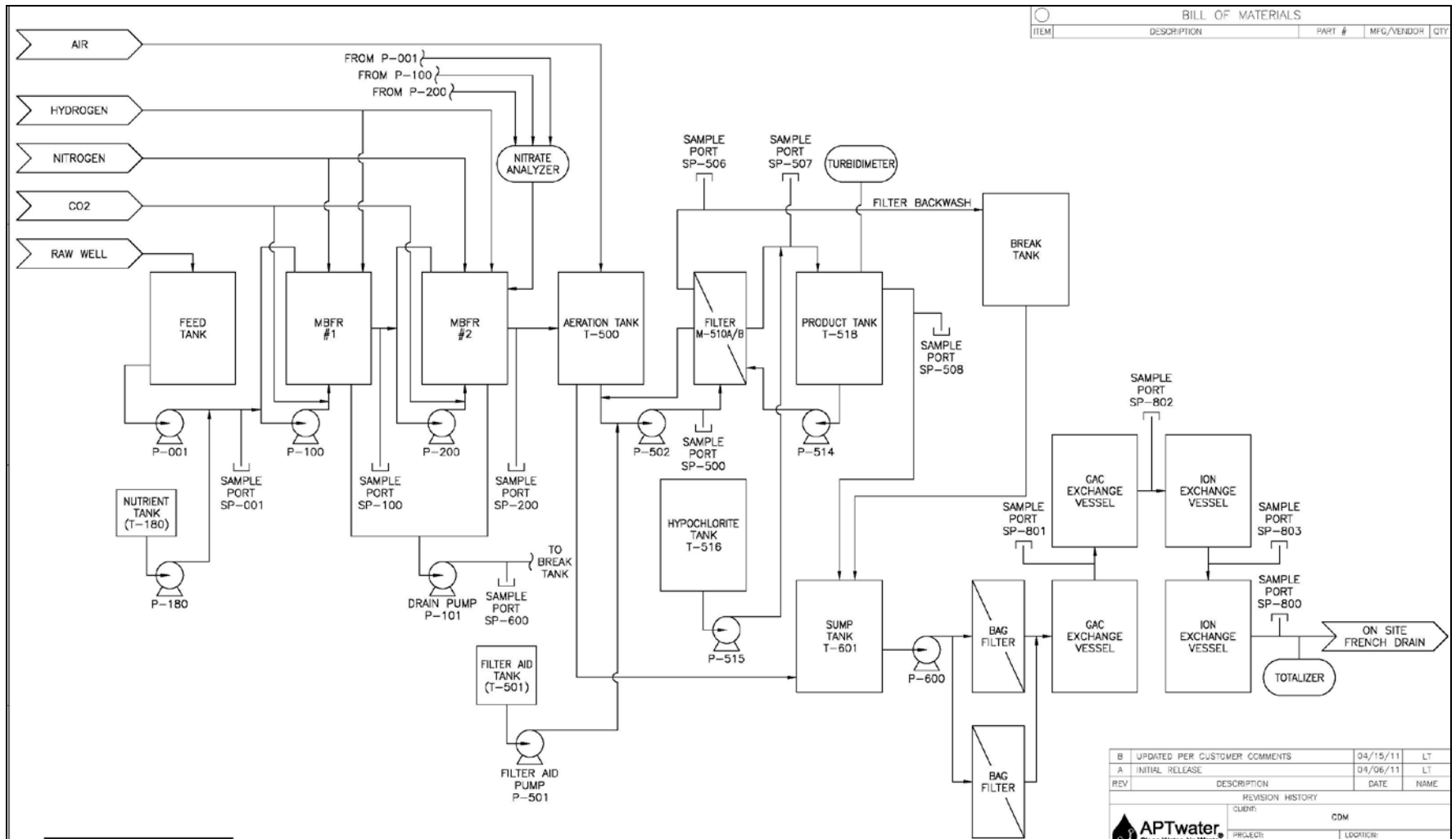

Figure 2.2 Process Flow Diagram

Factors Affecting Performance of the MBfR: A simple steady-state mass balance on the contaminant (perchlorate or nitrate) around the MBfR can be expressed as:

$$0 = QC_o - QC - JAV \quad (2.1)$$

where Q = volumetric flow rate, cubic meters per day (m³/d)
 C_o = influent contaminant concentration, grams per cubic meter (g/m³)
 C = effluent contaminant concentration, g/m³
 J = contaminant flux, grams per square meter per day (g/m²-d)
 A = biofilm specific surface area, square meters per cubic meter (m²/m³)
 V = MBfR volume, cubic meters (m³)

Rearranging (2.1) to solve for C provides a useful format for understanding in equation 2.2:

$$C = C_o - JAV/Q \quad (2.2)$$

The product JAV/Q gives the removal of the contaminant in terms of concentration. It shows the inherent trade-offs among J, A, and V for a given Q and C_o. For instance, large values of J, A, or both make it possible to have a small value of V, which leads to savings in construction and land costs. Likewise, a high value of the specific surface area (A) makes it possible to trade off high flux, and vice versa. In general, it is desirable to have a large flux (J). Factors that can lead to a large flux and that were considered in this project are:

- *Contaminant loading.* As a first approximation, the reduction kinetics for perchlorate degradation is first order, which means greater perchlorate concentrations increase J proportionally. Increasing influent flow rates increases contaminant loading.
- *Fast mass-transport of the contaminant from the bulk liquid to the surface of the biofilm.* This is controlled by turbulence, which depends on the liquid velocity past the biofilm. The liquid velocity is controlled by the amount of process water that is recycled. The liquid velocity was used to maintain an optimum biofilm thickness.
- *Hydrogen availability.* An increased hydrogen pressure, which controls the availability of the donor substrate to the biofilm, increases hydrogen and contaminant flux (Lee and Rittmann 2002). Hydrogen pressure controls the flux with a nearly linear relationship (Ziv-El and Rittmann 2009).
- *A high accumulation of the desired bacteria in the biofilm.* In this case, the key bacteria are those that reduce perchlorate and nitrate. While oxygen is a preferred electron acceptor followed by nitrate and nitrite, perchlorate reduction will occur once these competing electron acceptors are low enough. Previous research showed that perchlorate reducers are facultative anaerobes and can reduce nitrate and oxygen as well as perchlorate to gain energy and grow. This is called secondary utilization of perchlorate. In addition, other bacteria that can reduce oxygen and/or nitrate may also be present in the biofilm. Co-reduction of perchlorate, nitrate and oxygen at high rates is favored by having a high concentration of active biomass. This concentration depends on the influent groundwater chemistry as well as the MBfR staging. A high concentration of desired bacteria in the biofilm is preferable for high biofilm thickness because of mass transfer limitations and greater maintenance requirements.

- *Staging.* A high influent concentration of perchlorate drives faster kinetics, but is contrary to achieving a low effluent concentration. However, this conundrum is solved by having multiple stages in series. A high concentration occurs in the first stage so that J is high, but the next stage has a low C and J to meet lower effluent water quality objectives. J averaged over the entire system is increased considerably by staging (Levenspiel 1962), and this translates into smaller capital costs and space requirements.

Although high J is desirable for good performance and cost effectiveness, it is not the only factor that can be optimized to achieve the goals. The other powerful tool is achieving a high specific surface area, A . A high specific surface area can be attained by proper combination of two strategies:

- *Fine fibers with a high ratio of surface area to mass or volume.* The specific surface area of one fiber is inversely proportional to its diameter. Thus, making the diameter smaller automatically increases A . For instance, decreasing the fiber diameter from 300 micrometers (μm) to 100 μm increases each fiber's specific surface area threefold. This strategy is limited by the ability to manufacture a durable fiber in smaller diameters.
- *High packing density.* Increasing the number of fibers per unit volume of the MBfR makes the specific surface area proportionally higher. For instance, increasing the density from 3 percent of the reactor volume to 9 percent increases A threefold. The packing density should not be increased so much that it prevents good water-flow distribution in the fibers or that it allows the fibers to clump together.

Periodic pulsing with gas and backwashing are a means to prevent fiber clumping and maintain good flow distribution, despite using small fibers at a high packing density. Gas pulsing in the MBfR stages is conducted by sparging with nitrogen gas or alternatively with air.

2.2 TECHNOLOGY DEVELOPMENT

The MBfR technology for perchlorate and nitrate removal was invented, developed, and extensively tested by Dr. Bruce Rittmann and co-workers (Lee and Rittmann 2002; Nerenberg and Rittmann 2004; Nerenberg et al. 2003; Nerenberg et al. 2002; Rittmann and Lee 2002). Bench-scale MBfRs reduced perchlorate from 105 $\mu\text{g/L}$ to less than 4 $\mu\text{g/L}$ with a perchlorate flux of 23 milligrams per square meter per day ($\text{mg/m}^2/\text{d}$); this demonstrated the potential for the MBfR to be a cost-effective full-scale design. Additional research that validated perchlorate removal by hydrogen-fed autotrophs in bioreactors has been conducted by Dr. Bruce Logan (Logan and LaPoint 2002; Miller and Logan 2000; Logan et al. 2004). MBfR flux measured in Dr. Rittmann's laboratory demonstrated first-order reaction kinetics and the importance of hydrogen pressure. MBfR design data for a staged process based on Dr. Rittmann's data demonstrated the value of reactor staging (Rittmann et al. 2004). Increased hydrogen pressure countered the effect of increased nitrate loading to the MBfR (Lee and Rittmann 2002). These data supported MBfR responsiveness to changing water quality and operational conditions.

Pilot-scale testing of the MBfR technology and an engineering analysis were conducted at La Puente Water Treatment Plant in California (Adham et al. 2004). While the pilot system successfully reduced perchlorate from approximately 60 $\mu\text{g/L}$ to less than 4 $\mu\text{g/L}$ and generated a

wealth of operating experience, the typical flow rate of 0.3 gpm was too low to obtain accurate cost and performance data. Furthermore, the membrane module design used at La Puente was poorly suited for the MBfR and resulted in slow mass transfer and short-circuiting.

The microbial, functional, and structural interactions between perchlorate and nitrate reduction in the MBfR biofilm was recently investigated for an MBfR system that had complete reduction of perchlorate and nitrate when hydrogen was not limiting. The MBfR's biofilm was found to be composed of autotrophic genera *Sulfuricurvum*, *Hydrogenophaga*, and *Dechloromonas* dominating the biofilm (Zhao et al. 2011). The hydrogen-based MBfR also has been shown to be highly effective for reducing a wide range of oxidized contaminants beyond nitrate and perchlorate (Nerenberg and Rittmann 2004; Rittmann et al. 2004; Adham et al. 2005; Chung et al. 2006b; Chung et al. 2006c; Chung et al. 2006d). These include TCE, chromate, selenate, and bromate. Thus, the hydrogen-based MBfR removed multiple oxidized contaminants simultaneously. A list of oxidized contaminants that have been demonstrated with the MBfR to date is shown in Table 2.1.

Table 2.1 Chronological Development of the MBfR Technology

Year	Application	Scale	Efficiency/Loading / Removal Rate	Reference
2002	NO ₃ ⁻	Bench	92% - C ₀ 5 mg-N/L	(Lee and Rittmann 2002)
2002	ClO ₄ ⁻	Bench	30 to 99% - C ₀ 0.2 to 25 mg/L	(Nerenberg et al. 2002)
2003	ClO ₄ ⁻	Pilot	ClO ₄ ⁻ : 96% - C ₀ 55 µg/L NO ₃ ⁻ : >97% - C ₀ 5.5 mg-N/L	(Nerenberg et al. 2003)
2004	ClO ₄ ⁻ , NO ₃ ⁻	Lab, bench	ClO ₄ ⁻ : 95% - C ₀ 50 µg/L NO ₃ ⁻ : 76% - C ₀ 10 mg/L	(Rittmann et al. 2004)
2006	Arsenate [As(V)]	Lab	68% - C ₀ 0.142 mg/L	(Chung et al. 2006a; Chung et al. 2007)
2006	Chromate [Cr(VI)]	Lab	84% - C ₀ 1000 µg/L	(Chung et al. 2006d)
2006	Selenate [Se(VI)]	Lab	94% - C ₀ 260 µg/L	(Chung et al. 2006c; Chung et al. 2006b)
2007	Bromate (BrO ₃ ⁻)	Lab	>99% - C ₀ 1.5 mg/L	(Chung and Rittmann 2007)
2007	Bromate	Lab	>99% - C ₀ 1.5 mg/L	(Downing and Nerenberg 2007)
2007	NO ₃ ⁻ , ClO ₄ ⁻ , Se(VI), Cr(VI), As(V), Dibromochloropropane (DBCP)	Bench	NO ₃ ⁻ : >99% - C ₀ 10 mg-N/L; DBCP: below detection (BD) - C ₀ 1.4 µg/L; ClO ₄ ⁻ and ClO ₃ ⁻ : BD - C ₀ 82 µg/L	(Chung et al. 2007)
2008	NO ₃ ⁻ , ClO ₄ ⁻	Bench	NO ₃ ⁻ : 5.4 g-N/m ² -d ClO ₄ ⁻ : 5.0g ClO ₄ /m ² -d	(Van Ginkel et al. 2008)

Year	Application	Scale	Efficiency/Loading / Removal Rate	Reference
2008	1,1,1-Trichloroethane (TCA), TCE, Chloroform (CCl ₃)	Lab	87% (TCE), 95% (TCA), 99% (CCl ₄) - C ₀ 1000 µg/L of each	(Chung and Rittmann 2008)
2008	TCE	Lab	93% - C ₀ 1 mg/L	(Chung et al. 2008a)
2008	NDMA	Lab	96% - C ₀ 0.2 µg/L	(Chung et al. 2008b)
2009	NO ₃ ⁻	Lab	>99% - C ₀ 200 with 230 g-N/m ² -d loading	(Hasar 2009)
2009	NO ₃ ⁻ , ClO ₄ ⁻	Lab	NO ₃ ⁻ : >99.5% with 0.21 mg-NO ₃ ⁻ /cm ² -d loading; ClO ₄ ⁻ : 3.4 µg/cm ² -d loading	(Ziv-El and Rittmann 2009)
2011	<i>p</i> -Chloronitrobenzene	Lab	99.3% - C ₀ 2 mg/L	(Xia et al. 2011)
2011	2-Chlorophenol	Lab	94.7% - C ₀ 1-5 mg/L	(Xia et al. 2011)

East Valley Water District (EVWD) Perchlorate Reduction Demonstration

The first stage of this project involved a pilot-scale Demonstration of the MBfR at East Valley Water District (EVWD). An MBfR with post media filtration was demonstrated for perchlorate reduction using groundwater at EVWD Well 28A in San Bernardino, California. The six-month Demonstration included 1) a Start-Up phase designed to promote growth of perchlorate-reducing bacteria (PRB) on the membranes, and 2) an Optimization phase of variable operating conditions to test system performances, and to assess compliance with regulatory requirements.

The process included MBfR modules with cellulose triacetate (CTA) membranes, aerobic biodegradation, media filtration, and chlorination. Post-processing steps were integrated for the removal of DOC, TSS, bacteria, and disinfection. A series of quantitative and qualitative performance objectives were established for the Demonstration. The quantitative performance objective for perchlorate was an effluent concentration of 6 µg/L. The qualitative performance objectives of safety and permit compliance were specific for Demonstration activities *per se* rather than the technology, but were critical for the successful Demonstration. Taste and odor were considered a critical aspect of general public acceptance.

During Start-Up, perchlorate removal was achieved in about 6 weeks, with influent concentrations of approximately 50 µg/L reduced to less than 6 µg/L. However, perchlorate removal was not sustained because of excessive biofilm growth and short-circuiting as described below.

During the Optimization phase, the impacts of various operational parameters on perchlorate reduction and effluent water quality were investigated. These included influent flow rate, perchlorate concentration, and recirculation rate. The MBfR was tested over progressive increases in flow rates from 1 to 6 gpm to assess system performance under variable loadings. Influent concentrations of perchlorate (approximately 55 µg/L) and nitrate (approximately 7 mg-N/L) were constantly fed to the reactor during Optimization. Effluent perchlorate and nitrate

concentrations below the set success criteria were observed at a flow rate of 1 gpm. When the system flow rate increased from 1 gpm to 3 gpm, perchlorate performance was maintained. However, there was a slight increase in effluent nitrate and nitrite concentrations; thus the performance requirements for nitrate and nitrite were not met. The reactor performance abruptly deteriorated during the next 3 weeks when the system was operated at 6 gpm. Under these conditions, effluent perchlorate concentrations increased to approximately 45 µg/L and total nitrogen increased to approximately 3.8 mg-N/L. The influent flow rate was decreased from 6 gpm back to an intermediate flow of 3 gpm for 1 month. Although perchlorate and nitrate removal were slightly improved at 3 gpm to approximately 25 µg/L and 1.5 mg/L, respectively, the success criterion for perchlorate was not met. The flow rate was then decreased to 1 gpm, which resulted in effluent nitrate below detection and effluent perchlorate of approximately 18 µg/L after 2 weeks. Recirculation flow in the MBfR was increased from 90 to 180 gpm to further promote perchlorate reduction and to support system recovery. Although perchlorate reduction improved significantly (approximately 65 percent) and effluent nitrate was reduced to below detection, the perchlorate performance objective was not met. The feed perchlorate concentration was then reduced from 50 µg/L to 15 µg/L (i.e., the typical EVWD well 28A concentration) to determine if the MBfR was capable of achieving the 6-µg/L perchlorate goal when the feed concentration was lowered. This resulted in effluent concentrations lower than 6 µg/L, which met the success criterion for perchlorate.

The analysis of the results and visual examination of biofilm growth at the membrane surface revealed possible explanations of poor system performance. There was an uneven distribution of bacteria at the membrane surfaces in the three bioreactors, the high accumulation of biomass in the first stage and the limited biofilm density in the third stage indicated a poor biofilm control, and possible poor flow distribution, thus the loss of effective membrane surface area for mass transfer to occur. The membranes had regions sparsely populated with biofilm and other regions densely populated with biomass. Several areas had dark brown/black biomass, which indicated over-reducing conditions. A variety of operating configurations were unsuccessful in overcoming the maldistribution of biofilm and flow. The design of the membrane modules was concluded to be the primary factor causing maldistribution – the design included bundles of individual fibers that could not be sparged or backwashed effectively. An alternative membrane design was warranted to validate the feasibility of this technology. The MBfR modules from EVWD were redesigned to improve biofilm control and improve performance. The Demonstration at WVWD is the focus of this report, which was based on an MBfR with the revised design. Additional details are provided in Appendix H.

2.3 ADVANTAGES AND LIMITATIONS OF THE TECHNOLOGY

The membrane-based system for bio-reduction of perchlorate and nitrate has the following advantages:

- Perchlorate and nitrate are biologically reduced to chloride, water, and nitrogen gas. Thus, the target contaminants are eliminated, not transferred to another phase, as is the case for IX resin, tailored activated carbon, and reverse osmosis.
- Hydrogen-based bio-reduction in the MBfR uses an inorganic electron donor (i.e., hydrogen) and an inorganic carbon source (i.e., bicarbonate or carbon dioxide) for autotrophic bacteria.

This eliminates the need to supply an organic electron donor to support heterotrophic bacteria, as is the case for other biological treatment approaches such as fluidized bed reactors, packed or fixed bed reactors, and continuous stirred tank reactors. Advantages of autotrophy over heterotrophy include reduced biomass generation, decreased electron donor costs, lower residual organics requiring downstream treatment, lower potential for disinfection by-product formation because of lower residual organics, less potential for pathogen growth, and self-regulating control of the hydrogen-supply rate. Thus, the MBfR makes the biological reduction process simple, reliable, and less costly.

- Biological reduction of perchlorate with the MBfR is likely to be approved by regulators. For example, the CDPH, in reviewing pilot-scale work conducted at La Puente, stated in their June 16, 2003 letter, “The membrane biofilm reactor does appear to be a promising technology for perchlorate reduction” (Adham et al. 2004). The letter includes specific comments that are addressed as part of this Demonstration project.
- The hydrogen-based MBfR technology may also degrade other oxidized contaminants that often occur along with nitrate and perchlorate. These include selenate, chromate, bromate, and TCE. Thus, this technology may be used to solve many problems, which is not the case for other technologies such as IX.
- The media filter removes DOC that is present in the incoming water and that may be generated in the hydrogen-based MBfR. While the hydrogen-based MBfR adds some DOC, downstream processing with aerobic biologically active filtration can remove biodegradable DOC, making the water more biologically stable.

Limitations of the technology include:

- Multiple MBfR stages have not previously been demonstrated on a field scale to document consistent perchlorate removal or to establish a cost basis. This Demonstration project was specifically designed to address this limitation.
- The integration of the hydrogen-based MBfR with aeration and media filtration has not previously been tested for its ability to generate potable water. This Demonstration project was specifically designed to provide data necessary to critically evaluate performance.
- The ability to maintain stable control of the biofilm and prevent fouling in the MBfR has not been demonstrated at the pilot scale. This Demonstration project was specifically designed to address this limitation.
- The technology uses hydrogen, which is flammable. Engineering design of the MBfR system must comply with codes for design and operation of systems using hydrogen.
- The anoxic biological treatment process may increase chlorine demand. Higher chlorine doses may be required and result in higher formation of DBPs, chlorine demand, THM-FP, and DBPs including THMs and HAAs were measured in the Demonstration to assess this potential concern. On the other hand, use of hydrogen as the electron donor generates less biomass and thus less chlorine demand than biological treatment processes using heterotrophic bioprocesses.
- Biological perchlorate treatment may require greater operator attention, as it may be less robust with respect to process upsets compared to IX systems. The overall economics of perchlorate treatment will drive any decision regarding the implementation of biological treatment.

- The MBfR-based approach will require regulatory approvals for production of potable water. This Demonstration project was specifically designed to gather the information needed to support regulatory approval.

The primary technology used today for production of potable water from perchlorate-impacted water is IX. Other technologies that are at various stages in development include tailored activated carbon and various biological treatment technologies. A brief description of strengths and weaknesses of different technologies is summarized in Table 2.2. The fluidized bed bioreactor and the packed bed bioreactor have already received conditional acceptance from the CDPH for treating perchlorate-impacted water.

Table 2.2 Technological Comparison for Perchlorate Removal

Technology	Strengths	Weakness
Ion Exchange	<ul style="list-style-type: none"> • Full scale installations are in operation • Simple design and operation • High recoveries • Low cost and very effective 	<ul style="list-style-type: none"> • Can accumulate uranium and become a Technologically Enhanced Naturally Occurring Radioactive Material • Not a green technology (exhausted ion exchange resins are collected and sent for incineration or regenerated with brine as a waste stream)
Tailored Activated Carbon	<ul style="list-style-type: none"> • High capacity • Easy operation • Tested at pilot and full scale 	<ul style="list-style-type: none"> • Requires chemical or thermal activation • Not a sustainable technology (exhausted activated carbon is collected and sent for incineration) • Other components can leach creating secondary pollution • High cost of production and maintenance
Biological Treatment Technologies	<ul style="list-style-type: none"> • Proven effective for perchlorate reduction • Full-scale systems are under construction and nearing acceptance • Fluidized bed bioreactor and the packed bed bioreactor have received conditional acceptance from CDPH • Simple design and operation 	<ul style="list-style-type: none"> • Sensitive to water and environmental conditions • Require startup time • Fouling and clogging of various systems, if not maintained properly

3.0 PERFORMANCE OBJECTIVES

3.1 SUMMARY

Performance objectives were established for this Demonstration to provide a basis for evaluating MBfR performance and cost for the reduction in perchlorate, nitrate, and nitrite concentrations in groundwater. The performance objectives apply to the complete MBfR and post treatment process train, as summarized in Table 3.1.

Table 3.1 Performance Objectives

Performance Objective	Data Requirements	Success Criteria	Performance Objective Met?
Quantitative Performance Objectives			
Determine treatment effectiveness	Pre- and post-treatment concentrations of perchlorate, nitrate, and nitrite (NO ₂ ⁻)	Post-treatment concentrations: ClO ₄ ⁻ ≤ 6.0 µg/L NO ₃ ⁻ ≤ 0.5 mg-N/L NO ₂ ⁻ ≤ 0.5 mg-N/L	No - lag reactor effluent perchlorate was 9.2 µg/L (average) during Steady State. Yes - nitrate and nitrite were below 0.5 mg-N/L for all samples at the lag effluent during Steady State.
Determine disinfection effectiveness	Post disinfection concentrations of fecal coliforms, total coliforms, HPCs	Post-disinfection concentrations: fecal coliforms below detection total coliforms below detection HPCs ≤ 500 MPN/mL	Yes - fecal and total coliforms and <i>E. coli</i> were below the detection limit of 2 MPN/100 mL in all post-disinfection samples during Steady State. HPCs were on average 43 MPN/mL during Steady State and no sample was greater than 500 MPN/mL.

Performance Objective	Data Requirements	Success Criteria	Performance Objective Met?
Determine ability to meet drinking water treatment primary and secondary MCLs	Post disinfection odor, turbidity, organic carbon, and pH	TON \leq 3	Yes - TON was 2.2 on average, but 3 of 12 samples were above a TON of 3. These 3 samples were associated with process shutdowns because of high winds.
		Turbidity \leq 0.2 NTU	No – The average turbidity was 0.27 NTU and turbidity exceeded 0.2 NTU 33 percent of the time based on online measurements. Further optimization can address this issue.
		DOC increase \leq 0.2 mg/L	No - DOC increased an average of 0.4 mg/L from the system influent to post-disinfection during Steady State. However, this metric for distribution system stability is not driven by regulation and may be acceptable.
		6.5 \leq pH \leq 8.5 SU	Yes - pH was between 6.5 and 8.5 SU in all samples analyzed.
Reliability	Operating Records	\geq 95 percent uptime during steady state operational period	Yes - system up time during steady state was 98 percent.
Qualitative Performance Objectives			
Safety	Operating records	No reportable health and safety incidents	Yes – there were no reportable health and safety incidents.
Permit Compliance	Monthly permit reports	No violations	Yes – there were no permit violations.
Regulatory Acceptance	Review by CDPH	Obtain letter of conditional acceptance from the CDPH	Yes – Conditional acceptance for treatment of nitrate was received on July 26, 2013.

3.2 TREATMENT EFFECTIVENESS

The key performance objective in this Demonstration was to reduce perchlorate to below California regulatory levels and to reduce nitrate to less than 0.5 mg-N/L. Pre- and post-treatment samples were collected from the system influent, lead and lag MBfR effluents, and finished water effluent at regular intervals during the steady-state performance period. MBfR effluent concentrations of perchlorate, nitrate, and nitrite were measured and compared with the success criteria outlined in Table 3.1.

Perchlorate - US EPA determined that perchlorate can be regulated under the SDWA. EPA then began the process of determining and proposing a National Primary Drinking Water Regulation (NPDWR) for perchlorate to establish a national primary MCL in drinking water. In the absence of formal federal regulatory guidance, several states began regulating perchlorate in drinking water and in October 2007 California established an MCL of 6 µg/L (Lehman and Subramani 2011). Thus, the effluent perchlorate performance objective was 6 µg/L. Perchlorate was reduced from an average of 154±5 µg/L to an average of 9.2±2.3 µg/L in the effluent of the lag reactor during Steady State (94.4 percent reduction). Perchlorate was consistently removed with little variation (coefficient of variation was 0.75%). While the performance metric for perchlorate was not met, perchlorate was consistently reduced by more than 90 percent during Steady State, highlighting the reliability of this technology. Research conducted by ASU indicated that sulfate reducing bacteria likely provided too much competition with perchlorate-reducing bacteria for hydrogen and space in the biofilm, which led to an inability to achieve < 6 µg/L perchlorate. ASU experiments demonstrated complete perchlorate reduction in the absence of sulfate reduction when dissolved oxygen was intentionally fed to a lag reactor at a low electron acceptor flux (i.e., 0.18 g H₂/m²-day expressed as hydrogen equivalents). These results suggest that process modifications may promote complete perchlorate reduction in the MBfR (Rittmann et al. 2013).

Nitrate and Nitrite – Nitrate is a commonly observed contaminant in water. According to the NPDWR, the MCL for nitrate has been set at 10 mg-N/L, and for nitrite at 1 mg-N/L. Nitrate destruction was quantified using the sum of the nitrate and nitrite concentrations.

The performance objective for nitrate and nitrite was less than 0.5 mg-N/L. Total nitrogen was between 0.069 and 0.24 mg-N/L during steady state. Total nitrogen (the sum of nitrate and nitrite) was reduced from an influent average of 9.0 mg-N/L to an average of 0.12±0.07 mg-N/L in the effluent of the lag reactor during Steady State (98.3 percent reduction). Nitrate reduction was consistently removed with little variation (coefficient of variation was 0.94%), with the highest effluent total nitrate at 0.24 mg-N/L. The MBfR provided consistent removals despite some system upset conditions. Thus, the results met the metrics set for the nitrate and nitrite performance criteria.

3.3 DISINFECTION EFFECTIVENESS

Hypochlorite was used after MBfR biological reduction and media filtration as a disinfectant. HPCs were used as a surrogate indicator parameter for total bacteria. Total and fecal coliforms were used as an indicator of contamination by human or animal fecal wastes. The performance objective for disinfection was post-disinfection concentrations of total and fecal coliforms below detection and HPCs less than or equal to 500 colony forming units per milliliter (CFU/mL). The MCL for fecal and total coliforms is below the detection limit of 2 MPN/100 mL. Under NPDWR, HPC is regulated as a treatment technique (TT), a required process intended to reduce the level of a contaminant in drinking water. Under USEPA's SWTR, systems using surface water or groundwater under the direct influence of surface water must achieve a HPCs no greater than 500 MPN/mL (67 FR 1811).

During Steady State, hypochlorite concentrations were dosed to maintain a target free chlorine residual of 0.2 mg/L to meet CT requirements. Free chlorine residual at the disinfection basin was monitored to check that, at a minimum, the levels met CT requirements. Fecal and total coliforms were below the detection limit (2/100 mL) in all post-disinfection samples during the Steady State performance period. HPCs were on average 43 MPN/mL, and no sample was greater than 500 MPN/mL during Steady State. Thus, the performance objective for disinfection effectiveness was met.

3.4 ABILITY TO MEET DRINKING WATER TREATMENT PRIMARY AND SECONDARY MCLs

Treated water was required to comply with primary and secondary MCLs for drinking water. The parameters of interest include post-disinfection odor, turbidity, and pH. DOC is also of interest because it can contribute to water instability in the distribution system and is a potential source of disinfection byproducts.

Odor - Biological reduction processes in the MBfR can potentially lead to the formation of odors. Under the conditions favorable to nitrate and perchlorate reduction, sulfate reduction may also occur, resulting in formation of sulfide. USEPA National Secondary Drinking Water Regulations (NSDWR) require a secondary standard of TON equal to or less than 3 to be considered as aesthetically acceptable finished water and this was set as the performance objective. Quantitative measurements of odors were performed in the finished water. An average TON of 2.2 was observed during Steady State; however, there were three exceedances of 12 samples collected. These exceedances were associated with process shutdowns that occurred because of high winds. The process shutdowns resulted in a non-flowing system which resulted in over-reducing conditions and resultant sulfate reduction. The metric for this performance objective was met based on the average TON.

Turbidity - Fine particles resulting from biological treatment can cause an increased turbidity in the effluent, which can make water aesthetically unacceptable. While turbidity *per se* is not a major health concern, it can be associated with presence of pathogens and can affect disinfection efficiency. Media filtration in combination with a coagulant filter aid was employed to meet turbidity requirements. Turbidity was monitored throughout the treatment system, but for this performance objective, the success criteria were compared to the media filter effluent turbidity. The performance objective for turbidity in the finished water was less than or equal to 0.2 NTU. An average turbidity of 0.27 NTU was observed from online measurements during normal steady state operation. The average turbidity value was higher than the performance criteria and thus this performance objective was not met. Further optimization of the media filtration process would result in meeting the objective.

Dissolved Organic Carbon – Residual biodegradable organic compounds in treated water can decrease water biostability and promote regrowth of organisms in distribution systems. DOC was selected as a surrogate indicator for biological stability. The performance objective for DOC required the increase in the system to be less than or equal to 0.2 mg/L. DOC samples were collected throughout the treatment system. For this performance objective, the increase in DOC was measured from the system influent to the finished water. An average DOC increase of

0.4 mg/L from the system influent to post-disinfection was observed during Steady State. The net increase in DOC exceeded the performance objective indicating that treated water was less biologically stable. Hence the performance objective for biological stability was not met during Steady State. On the other hand, biological stability is specific to a particular distribution system and the observed increase in DOC may be acceptable. Disinfection byproducts and byproduct potentials were below MCLs. Haloacetic acids (HAA5) were below detection ($< 6 \mu\text{g/L}$) and total trihalomethanes (TTHMs) averaged $4.8 \mu\text{g/L}$ compared to the MCL of $80 \mu\text{g/L}$. Nitrosamines were measured and not detected.

pH - pH control and monitoring was essential as most of the chemical and biological reactions in aquatic environment occur within an optimal range. In particular, pH control was important for this system since denitrification and other reduction processes can result in increased alkalinity and increased pH. Desirable pH typically lies in the range of 6.5 to 8.5 SU, which is a secondary MCL under the NSDWR. A variation in treated water pH from this range may pose health, infrastructure (e.g. corrosion), and public acceptability issues. Under NSDWR, USEPA recommends these secondary standards to water systems but does not require systems to comply. During the MBfR Demonstration, the pH of the finished water remained within the performance standards of 6.5 to 8.5 SU. An average value of 7.8 ± 0.2 SU was observed during the Steady State period. The metric for this performance objective was met.

3.5 RELIABILITY

Reliability of the treatment processes plays an important role in planning and designing of any water treatment facility. The goal during this Demonstration was to guarantee high quality treated water, particularly from a public health standpoint. Robust system performance indicates the ability of a specific process to meet all the water quality standards, regardless of anticipated fluctuations in raw water quality or operating conditions.

For this performance objective, the reliability of the MBfR system was measured as the up time during the one-month long Steady State phase. The performance objective was set to have at least ≥ 95 percent uptime during the steady state operational period. Overall system up time of 98 percent was observed, which confirmed the reliability of the MBfR technology. The performance objective on system reliability was met.

3.6 SAFETY

Safety concerns linked to water and wastewater treatment operations often originate from the use of hazardous chemicals and gases; thus, metrics of safety performance were included among the qualitative performance objectives to be met during the MBfR Demonstration. In particular, the use of pressurized gases such as hydrogen (flammable), nitrogen, and CO_2 , increase the level of risk and hazard, requiring additional safety measures to be implemented. Flammability associated with the use of hydrogen gas was of main concern and required specific engineering design measures including explosivity sensors and automatic shutdown provisions for safe gas use. Other measures including placarding in the area to prevent sources of ignition and appropriate health and safety training were also required.

Metrics for meeting the safety performance objective included no reportable health and safety incidents during the Demonstration site. Health and safety incident reports and regular monitoring of gases at the Demonstration site were used to evaluate this performance objective. There were no health and safety incidents reported during the Demonstration. Flammable gas concentrations were not detectable during various times at the field site. During the few instances when a hydrogen leak was detected, the system was automatically shut down. The metric for this performance objective was met.

3.7 PERMIT COMPLIANCE

Contaminated groundwater was used for the MBfR technology Demonstration. The water was treated through the MBfR process followed by post disinfection, and a final polishing step using GAC and IX filters before being injected back into the aquifer. The California Regional Water Quality Control Board (RWQCB) requires a permit for any such re-injection of treated water. California RWQCB issued permit number R8-2002-0033-038 for the re-injection of treated water into groundwater during this Demonstration. Monitoring of influent and effluent parameters was conducted during this study and monthly permit compliance reports were submitted per the permit requirements. No violations of the permit occurred during this MBfR Demonstration. Thus, the metric for this performance objective was met.

3.8 REGULATORY ACCEPTANCE

This performance objective was to obtain a letter of conditional acceptance from the CDPH. A letter indicating conditional acceptance for the MBfR for treatment of nitrate was received from the CDPH on July 26, 2013 (Appendix I). This is the process by which the State of California evaluates unconventional alternative treatment technologies for compliance with drinking water treatment regulations under Title 17 and 22 of the California Code of Regulations. APTwater has constructed a full-scale system for potable water treatment of nitrate using the MBfR technology at Cucamonga Valley Water District in California. This system is in the process of being permitted by CDPH for full-scale operation.

4.0 SITE DESCRIPTION

4.1 SITE LOCATION AND HISTORY

The first stage of this project involved a pilot-scale Demonstration of the MBfR at EVWD in San Bernadino, California, using water from EVWD Well 28A. Results from this pilot-scale Demonstration were discussed in Section 2.2. This second stage of this project was conducted at WVWD's Well 22 in Rialto, California (Figure 4.1). The EVWD Well28A location is also shown on Figure 4.1 for reference. WVWD Well 22 was a former agricultural well that was not being used as a water source prior to the Demonstration. The site is bounded by Vineyard Avenue to the north, Linden Avenue to the east, and West Norwood Street to the south. The areas surrounding the well are mixed residential, agricultural, and industrial. The City of Rialto Municipal Airport is located less than one mile south of the well. Contamination of perchlorate and volatile organic compounds (VOCs) is believed to have originated from weapons/explosives manufacturing and storage at the Rialto Ammunition Storage Point (RASP) northwest of the well site. The RASP was operated by the U.S. Army from 1942 to 1945. The site was owned and occupied by West Coast Loading Corporation (WCLC) until 1957. WCLC performed the loading, assembly and testing of munitions with perchlorate for the US Army and Navy. B.F. Goodrich owned and operated the site for propellant manufacturing and testing until 1963. The site was sold by B.F. Goodrich in the 1960s and was subsequently used by various defense contractors, fireworks, and pyrotechnics companies. The nearby Mid-Valley Sanitary Landfill is another known source of VOCs (GeoSyntec 2005).

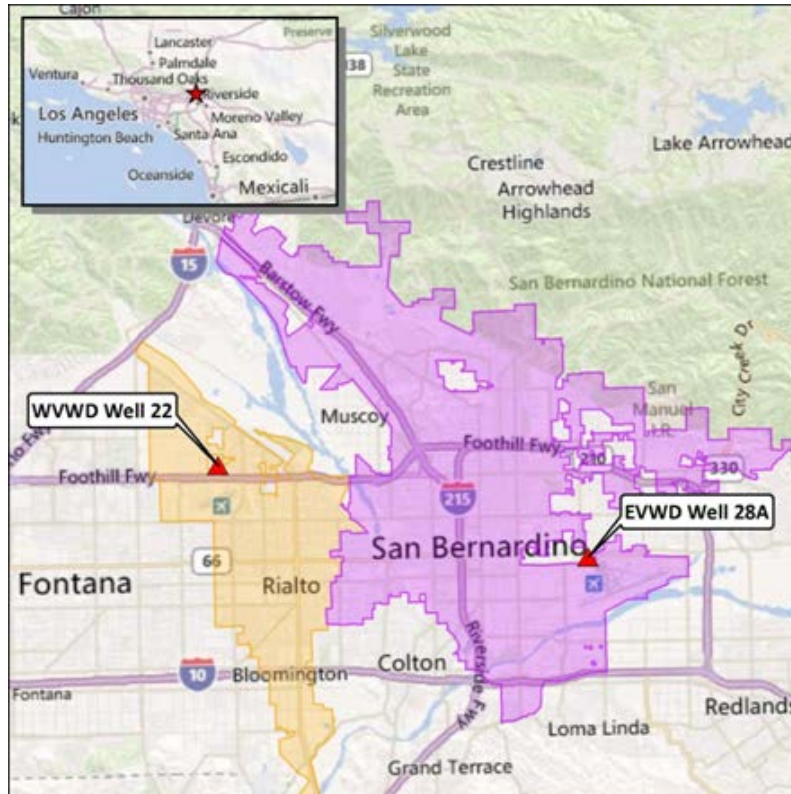

Figure 4.1 Site Vicinity Map

4.2 SITE GEOLOGY/HYDROGEOLOGY

WVWD Well 22 is located within the Rialto-Colton groundwater basin. Numerous subterranean barriers and faults direct groundwater flow within the basin. The basin is largely comprised of unconsolidated alluvial sediments. The aquifer system beneath the site consists of coarse to medium sand and gravel to 200 feet below ground surface (ft bgs) underlain by sand to 500 ft bgs. The upper water-bearing unit begins at the surface and extends to 130 ft bgs. The middle water-bearing unit lies directly underneath the upper unit and extends to greater than 1,000 ft bgs. The water bearing units within the basin are unconfined and are hydraulically connected to each other. Consolidated deposits and a basement complex composed of metamorphic and igneous rocks underlie the water-bearing units. Recharge to the Rialto-Colton groundwater system comes from a number of sources. Manual recharge with imported water, underflow across faults, inflow from rivers and drainages, and infiltration (rainfall and irrigation water) provide the majority of recharge to the system (Wooldenden and Kadhim 2005).

4.3 CONTAMINANT DISTRIBUTION

The primary contaminants of concern in groundwater in the Rialto-Colton basin are perchlorate, nitrate, and trichloroethene (Figure 4.2). The plume extends from the RASP source area in the northwest toward the southeast and is more than 3 miles long and half a mile wide. Historically, perchlorate and TCE concentrations have been measured in the source area as high as 10,000 and 420 $\mu\text{g/L}$, respectively (GeoSyntec 2007). In 2011, perchlorate and TCE concentrations in the plume were observed as high as 1,100 and 42 $\mu\text{g/L}$, respectively (USEPA 2011). Historical water quality data at Well 22 that was available prior to the Demonstration are shown in Table 4.1.



Figure 4.2 Approximate Extent of Perchlorate Contamination

Table 4.1 Historical Water Quality at Well 22

Analyte	Units	Dates	Minimum	Average	Maximum
Alkalinity	mg/L as CaCO ₃	8/21/2003	NA	150	NA
Chloride	mg/L	8/21/2003	NA	7.3	NA
Hardness	mg/L as CaCO ₃	8/21/2003	NA	170	NA
Nitrate	mg-N/L	3/21 and 9/10/2008	9.9	10	10
Perchlorate	µg/L	3/21/2008 to 1/27/2009	79	90	100
pH	SU	8/21/2003	NA	7.3 – 7.7	NA
Sulfate	mg/L	8/21/2003	NA	21	NA
TCE	µg/L	3/21/2008 to 1/27/2009	23	25	30
Total dissolved solids	mg/L	8/21/2003	NA	230	NA

Note:

NA – Not applicable

5.0 TEST DESIGN

This section provides a detailed description of the MBfR system design, operation, and testing conducted for the Demonstration.

5.1 CONCEPTUAL EXPERIMENTAL DESIGN

This nine-month Demonstration was initiated in April 2011 using perchlorate- and nitrate-contaminated groundwater from WVWD Well 22 in Rialto, California. The treatment system included two anoxic MBfRs operated in series to reduce oxygen to water, nitrate to nitrogen gas, and perchlorate to the chloride ion. The first MBfR vessel had seven membrane modules that were primarily used for reduction of oxygen and nitrate. The second MBfR vessel contained seven membrane modules and primarily reduced the remaining nitrate and perchlorate. Phosphorous was supplemented as a nutrient and carbon dioxide was amended for pH neutralization and control of hardness precipitation and as a carbon source for microbial cell synthesis. Post-MBfR treatment processes included aeration to re-oxygenate the water, media filtration supplemented with a coagulant/filter aid to remove suspended solids, and disinfection using sodium hypochlorite. Additional post-treatment to meet RWQCB permit requirements involved GAC for VOCs and IX for perchlorate. The experimental design had four phases (Figure 5.1).

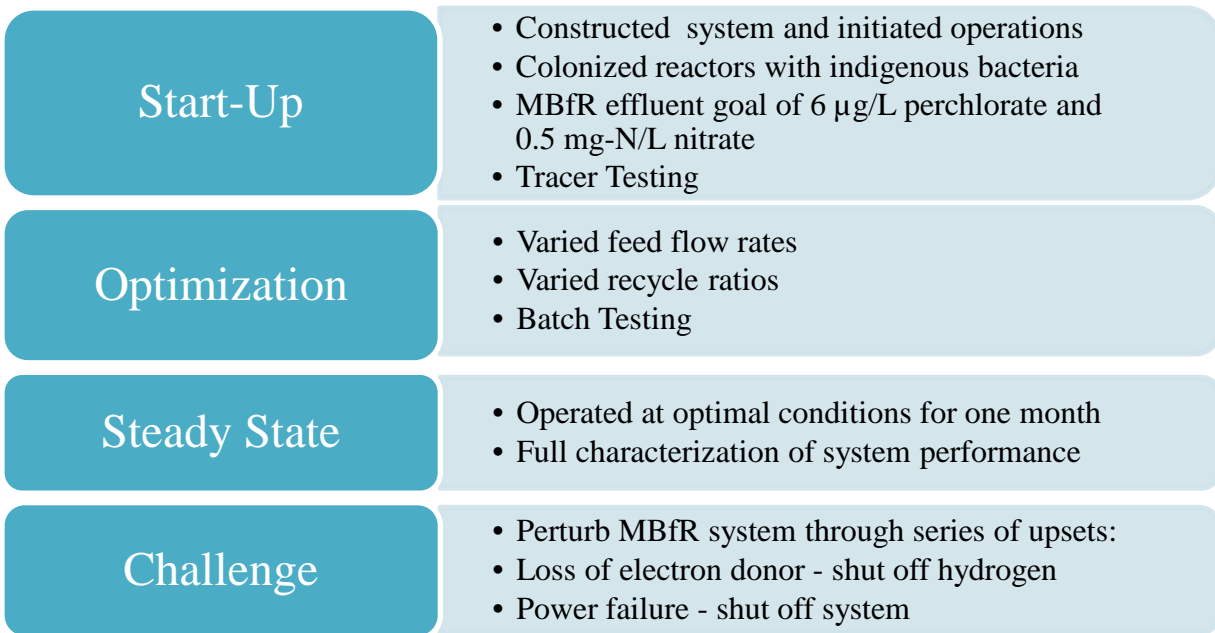

Figure 5.1 Experimental Design

Start-Up was initiated after construction of the system was complete and the system was placed on-line. During Start-Up, indigenous bacteria colonized the membranes to form an active biofilm. The goals for completion of Start-Up included nitrate concentrations below 0.5 mg-N/L and perchlorate below 6 µg/L. The second phase was Optimization during which operational conditions were varied to assess system performance. The goal was to determine which operating conditions produced peak performance in terms of perchlorate and nitrate removal. The third

phase was a period of Steady State to assess process stability and sensitivity to changes in influent water quality conditions. System stability is a critical condition for potable water production. The final stage of the Demonstration was the Challenge phase. This included intentional process upsets to assess resiliency and reliability of the technology. Four system upset tests were conducted: a 4-hour and 24-hour shut-off of hydrogen, as well as a 4-hour and 24-hour full system shut down. Testing of the system was conducted during the rebound period after each upset condition.

5.2 BASELINE CHARACTERIZATION

Baseline characterization consisted of obtaining historical monitoring data for groundwater chemistry from WVWD. Historical monitoring data were obtained from 2003 to 2009. The average concentration of perchlorate was 90 µg/L and nitrate was 44.5 mg-N/L. See Section 4.3 for a description of the contaminant distribution. Groundwater quality was slightly different during the Demonstration than historical monitoring results (Table 5.1) because the original groundwater flow from Well 22 was lower than what was planned during the Demonstration, at approximately 1 gpm. In April 2011, the pump at WVWD Well 22 was replaced with a Grundfos 25S50-26 submersible pump, and the intake was moved from 474 ft bgs to 483 ft bgs to increase water production to 30 gpm.

Table 5.1 Summary Statistics for Influent Water Quality at Well 22 throughout the Demonstration from April 2011 to January 2012

Analyte	Units	Average	Standard Deviation	Count
Alkalinity	mg/L as CaCO ₃	150	11.3	28
Hardness	mg/L as CaCO ₃	200	7.5	27
Nitrate	mg-N/L	8.82	0.38	32
Perchlorate	µg/L	170	17	70
pH	SU	7.5	0.11	71
Sulfate	mg/L	21	0.85	27
TCE	mg/L	54	7.0	28
TDS	mg/L	260	15	28

5.3 TREATABILITY OR LABORATORY STUDY RESULTS

Numerous bench- and pilot-scale studies have been conducted demonstrating the feasibility of hydrogen MBfR for treatment of perchlorate and nitrate (see Section 2.2 for a detailed description of technology development). Additional laboratory work was conducted in conjunction with the field effort by ASU and is reported separately (Rittmann et al. 2013). The ASU Team carried out multiple experiments to decipher why the two-stage MBfR system did not achieve the 6µg/L effluent perchlorate goal. The team carried out extensive analyses of hydrogen, oxygen, nitrate, perchlorate, and sulfate fluxes during the pilot study and correlated them to a range of analyses conducted on the MBfR side-reactors from the pilot. These side-reactors contained hollow-fiber membranes and were fed water from a side-stream of the pilot-scale system. These were sampled and sent to ASU for analysis. ASU also carried out bench-scale MBfR experiments and developed mechanistic mathematical models to identify and quantify the

kinetic and ecological mechanisms underpinning the performance of the pilot and bench-scale MBfRs.

A large amount of biomass accumulated between the spacers in the pilot side reactor laboratory modules. Biofilm thickness in the MBfR side-reactor lab modules was typically approximately 200 μm . The biofilm was only approximately 10 percent inorganic, which indicated that hardness precipitation was effectively mitigated by pH-control. While the biofilm contained between 40 and 50 percent extracellular polymeric substances (EPS), the cells were predominantly living, particularly near the membrane substratum. The biofilm communities were similar between lead and lag MBfR, where the community of perchlorate-reducing bacteria (PRB) made up the smallest fraction of the active bacteria [determined by quantitative polymerase chain reaction (qPCR)]. From bench-scale MBfRs at ASU, *Dechloromonas* was an important denitrifying bacteria (DB) and PRB when perchlorate reduction was successful. However, *Dechloromonas* were not always the main PRB. However, sulfate-reducing bacteria (SRB) always were present, and SRB became more numerous when the electron acceptor surface loading was significantly decreased in an attempt to drive perchlorate to non-detectable levels. As SRB became more numerous, their greater demand for hydrogen a competition for space in the biofilm led to an inability to achieve the perchlorate treatment objective of 6 $\mu\text{g/L}$.

The ASU studies concluded that the fluxes of oxygen, nitrate, and sulfate need to be managed in order attain the 6- $\mu\text{g/L}$ perchlorate treatment objective and simultaneously prevent sulfide generation. Electron acceptor fluxes were normalized by hydrogen consumption flux ($\text{g H}_2/\text{m}^2\text{-day}$) for comparison. A moderate flux of nitrate and oxygen helped promote PRB growth and perchlorate-reduction while preventing sulfate reduction. Modeling indicated that a flux of combined nitrate and oxygen of 0.036 to 0.21 $\text{g H}_2/\text{m}^2\text{-day}$ promoted perchlorate reduction, while a flux of greater than 0.36 $\text{g H}_2/\text{m}^2\text{-day}$ caused serious inhibition of perchlorate reduction. Modeling demonstrated that a flux of 0.2 to 0.4 $\text{g H}_2/\text{m}^2\text{-day}$ prevented sulfate-reduction, with a recommended target flux of $\sim 0.3 \text{ g H}_2/\text{m}^2\text{-day}$. Bench-scale testing with a synthetic medium demonstrated that complete perchlorate reduction was possible at a combined nitrate and oxygen flux of up to 0.25 $\text{g H}_2/\text{m}^2\text{-day}$. In a bench-scale two-stage MBfR fed Rialto groundwater, a nitrate and oxygen flux of 0.18 $\text{g H}_2/\text{m}^2\text{-day}$ stopped sulfate reduction, despite the fact that SRB were present. Bench-scale results suggested that sulfate reduction did not necessarily slow perchlorate reduction, although the pilot results gave the best perchlorate reduction when sulfate flux was lowest (combined nitrate and oxygen flux of greater than 0.17 $\text{g H}_2/\text{m}^2\text{-day}$). When using groundwater collected from the site, a nitrate and oxygen flux of less than or equal to 0.18 $\text{g H}_2/\text{m}^2\text{-day}$ allowed full perchlorate reduction, while partial degradation ($\sim 30\%$) occurred at greater than $\geq 0.21 \text{ g H}_2/\text{m}^2\text{-day}$.

Similar trends were observed in the pilot MBfRs. When hydrogen was limiting, a NO_3^- flux of 0.3 $\text{g H}_2/\text{m}^2\text{-day}$ suppressed SO_4^{2-} reduction in the pilot lag MBfR. When hydrogen delivery was not limiting, a NO_3^- flux of 0.17 $\text{g H}_2/\text{m}^2\text{-day}$ slowed SO_4^{2-} reduction. Modeling runs using conditions in the pilot-scale reactors suggested that external mass-transport resistance was greater in the pilot-scale than bench-scale MBfRs. Modeling also showed that the pilot-scale reactors may have selected for different and less-efficient PRB. A significant difference between the ASU laboratory studies and the pilot-scale studies was that DO was introduced into the ASU lag reactor. This occurred because water from the lead reactor was collected and then fed to the

lag reactor. The water became oxygenated by this process. This difference led to inhibition of sulfate reduction and attainment of complete perchlorate reduction in the ASU lag reactor. DO did not enter the pilot-scale lag reactor, thus sulfate reduction was not inhibited and complete perchlorate reduction was observed only when sulfate reduction occurred.

In summary, the modeling and bench-scale tests conducted by ASU showed no intrinsic roadblock for achieving a very low perchlorate concentration in the absence of sulfide generation. Attainment of this goal would require managing nitrate and oxygen loading to promote PRB growth and suppress sulfate reduction. A two-stage treatment train may not be the best configuration for this goal. If a two-stage system is used, particular attention has to be paid to nitrate and oxygen loading to the lag MBfR. While the results did not have an exact target value, they suggested that the lag MBfR should have a total hydrogen demand flux for nitrate and oxygen of around $0.18 \text{ g H}_2/\text{m}^2\text{-day}$ to achieve desired perchlorate reduction without significant sulfate reduction.

5.4 DESIGN AND LAYOUT OF TECHNOLOGY COMPONENTS

This section describes the design attributes of equipment used for this Demonstration. The major MBfR treatment processes included:

- MBfR vessels operated in a lead/lag configuration – two 575-gallon polyethylene tanks with seven membrane modules per vessel
- Aeration tank – 350-gallon polyethylene tank with Danner Manufacturing AP-100 air compressor pump and a ClearWater™ 7-inch round, 1.5-inch thick aeration stone
- Media filters operated independently – two 21-inch diameter, 62-inch tall media filtration units filled with Next-Sand™ media
- Product (finished water) tank - 1000-gallon polyethylene tank
- GAC filtration vessels operated in a lead/lag configuration – two 36-cubic foot (CF) steel vessels, 36 inches diameter and 77-inches tall filled with Calgon F300 8 x 30 mesh GAC
- IX resin vessels operated in a lead/lag configuration – two 36-CF steel vessels, 42 inches diameter and 48-inches tall filled with CalRes 2109 IX resin

The treatment system facing east is shown in Figure 5.2. The system was placed within a secondary containment structure with Conex shipping container on the north and south sides of the skid for protection from seasonal high winds (i.e., the Santa Ana winds). A cover was also placed above the skid to protect equipment from direct sun exposure and rain. The California Building Code requirements for wind loading were followed for calculating structure requirements. The MBfR and post- treatment system are shown in Figure 5.3. The GAC and IX resin vessels were added to meet permitting requirements for discharge to groundwater. They were placed within the southern Conex container. A process flow diagram showing actual units used in the Demonstration are shown in Figure 5.3, and the piping and instrumentation diagram (P&ID) is shown in Figure 5.4. Figure 5.5 shows the P&ID for the individual membrane modules (7) in each vessel.

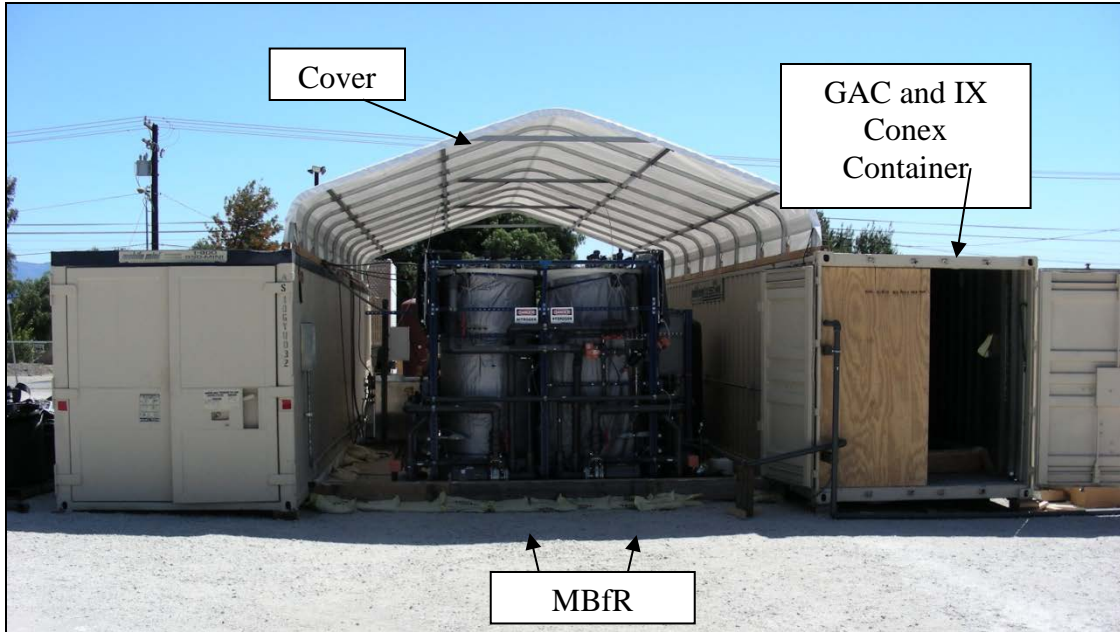

Figure 5.2 MBfR Treatment System

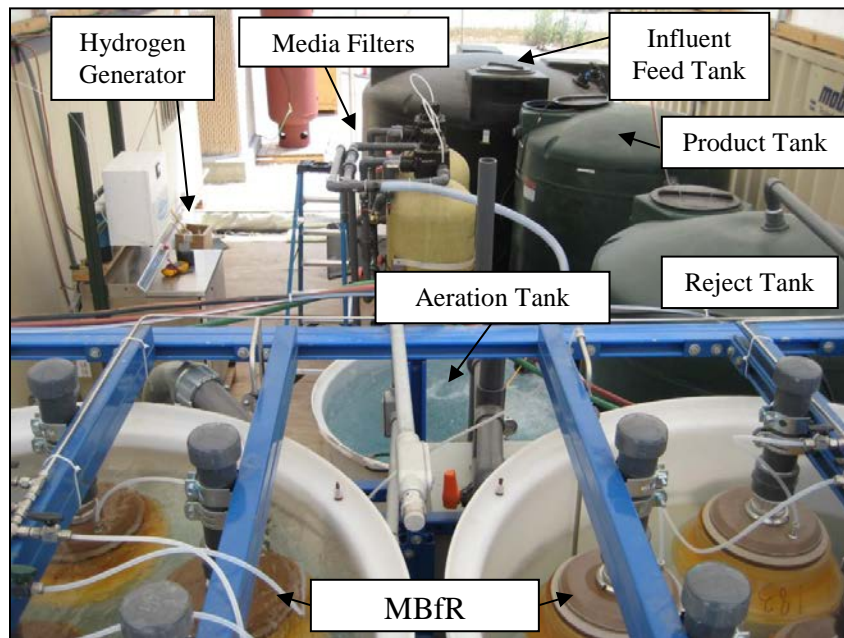

Figure 5.3 MBfR Treatment System Arrangement



Figure 5.4 MBfR Treatment System Process Flow

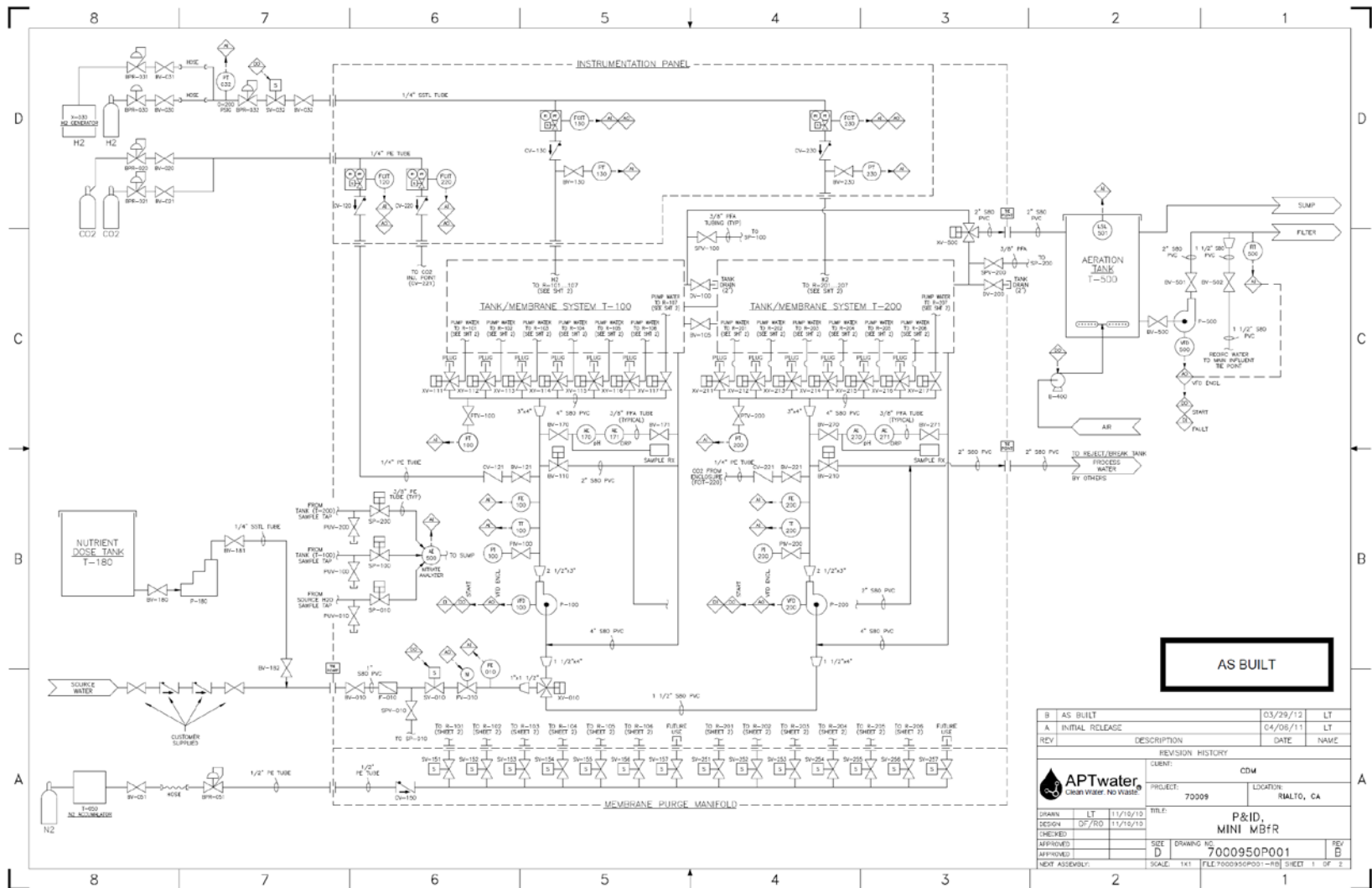

Figure 5.5 MBfR Pilot Treatment Plant Piping and Instrumentation Diagram

B	AS BUILT	03/29/12	LT
A	INITIAL RELEASE	04/06/11	LT
REV	DESCRIPTION	DATE	NAME
REVISION HISTORY			
CLIENT: CDW		PROJECT: 70009	
LOCATION: RIALTO, CA		TITLE: P&ID, MINI MBfR	
DRAWN: LT	11/19/10	SCALE: 1/4"	FILE: 7000950P001-101
DESIGN: GF/RD	11/19/10	DRAWING NO: 7000950P001	SHEET 1 OF 2
CHECKED:		SCALE: 1/4"	FILE: 7000950P001-101
APPROVED:		SCALE: 1/4"	FILE: 7000950P001-101
APPROVED:		SCALE: 1/4"	FILE: 7000950P001-101
APPROVED:		SCALE: 1/4"	FILE: 7000950P001-101

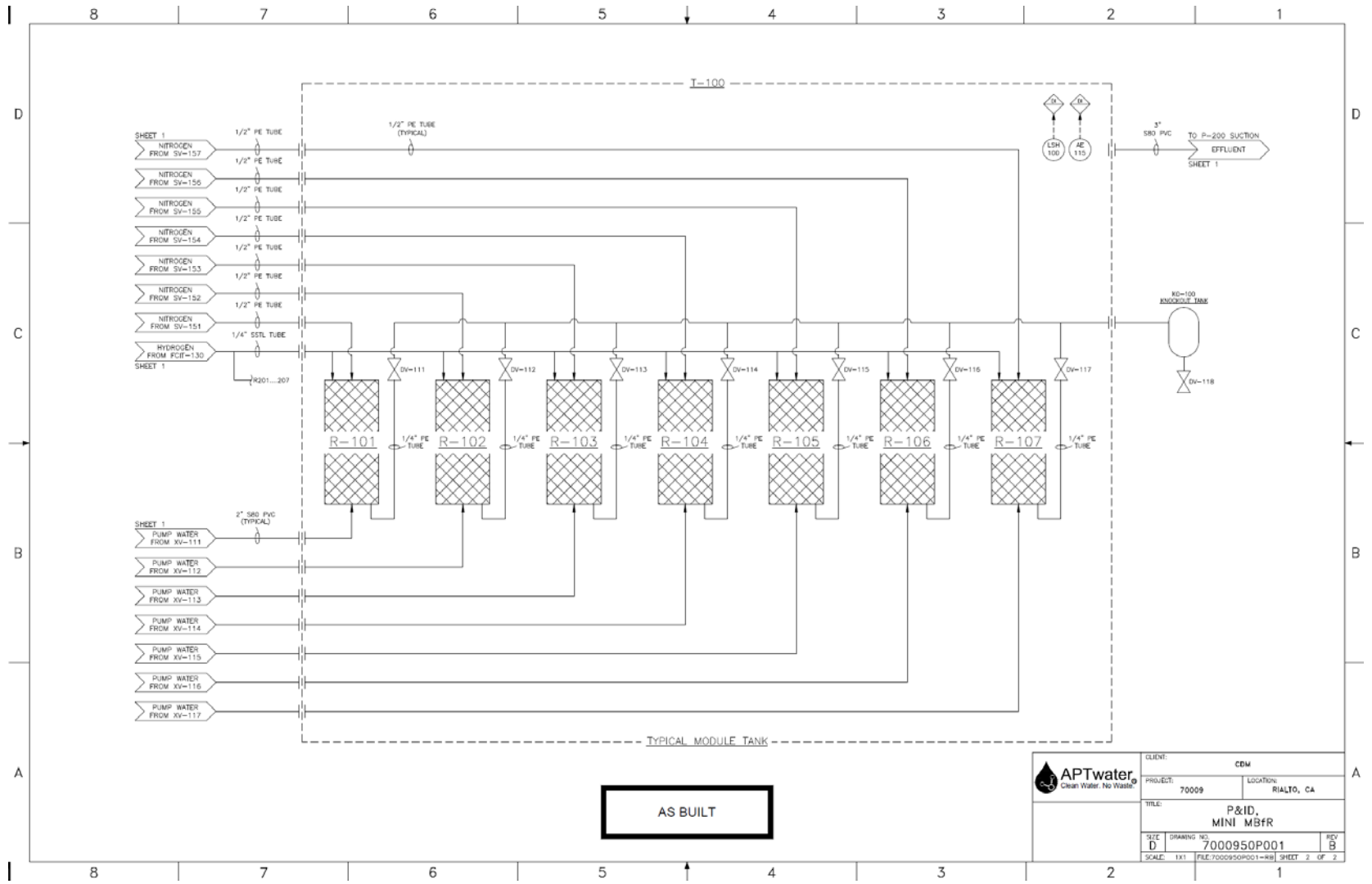

Figure 5.6 MBFR Vessel System Piping and Instrumentation Diagram

5.4.1 Process Equipment

Influent Well

Well 22 had a Grundfos 25S50-26 variable frequency drive submersible pump capable of 30 gpm at 460 feet of head. The pump intake was set at 483 ft bgs and the well was screened from 430 to 492 ft bgs. Operation of the well was controlled by low- and high-level switch floats in the influent feed tank that were tied to the well control panel. The influent well pump was also tied to secondary containment switches so that the pump would not operate if a secondary containment level switch was engaged. Influent well water was routed to a 2,500-gallon polyethylene feed tank through a 1.5-inch influent line. A Goulds 1ST 1.5-horsepower pump (P-001) was used to pump water from the raw water feed tank to the MBfR system through a 2-inch discharge line. The tank diameter was 95 inches and the height was 89 inches. The tank was black to prevent algal growth.

Gas Supply Pad

The MBfR system required supplementation of hydrogen as the electron donor, carbon dioxide for pH control, and nitrogen as an anoxic inert gas. The theoretical hydrogen feed requirement was based on the oxygen, nitrate, and perchlorate demand. The oxygen demand is associated with aerobic respiration. Oxygen is a more energetically favorable electron acceptor so reduction of oxygen occurs preferentially followed by nitrate, nitrite, and perchlorate (Nerenberg et al. 2008; Lee and Rittmann 2002). The stoichiometric ratios for hydrogen to oxygen, nitrate, and perchlorate are shown in Section 2.1. The membrane hydrogen pressure was adjusted based on stoichiometric dosing requirements. The actual hydrogen throughput was pressure regulated “on demand” by bacterial utilization of hydrogen on the exterior surface of the membrane. The rate of flow across the membrane was dependent on the interior pressure on the lumen and the concentration gradient between the lumen and the exterior surface. Pure hydrogen was present in the lumen and as bacteria on the membrane exterior consumed hydrogen, a gradient was established which increased the flow rate of hydrogen across the membrane. The faster bacteria consumed hydrogen, the faster hydrogen would permeate through the membrane. Additionally, as the pressure on the interior of the lumen increased the driving force for hydrogen across the membrane correspondingly increased.

Carbon dioxide was supplemented for pH control to the membrane lumen and to the vessel bulk water. The reduction reactions produce alkalinity, which increases the pH. Carbon dioxide was dosed to control pH at 7.2 SU using online probes. The pH was selected to maintain a pH that was conducive to biological growth and to maintain a negative Langelier Saturation Index (LSI) to prevent formation of carbonate in the biofilm. The LSI is determined based on specific water quality parameters and is used as an indicator of the formation of calcium carbonate and magnesium carbonate scale. The pH was monitored using online probes in each MBfR vessel and controlled by the operator interface terminal (OIT) and programmable logic controller (PLC). Nitrogen gas was supplied for control of biomass growth on the membranes through sparge events. Nitrogen gas was used rather than compressed air to maintain anoxic conditions within the reactor.

Hydrogen was supplied by a Proton Energy Systems HOGEN® S series, model 40 generator. The generator used a proton exchange membrane that produced hydrogen at a rate up to 40

standard cubic feet per hour (SCFH) at 70 degrees Fahrenheit and one atmosphere of pressure. The unit's hydrogen purity specification was 99.9995%. ASTM Type II deionized water was supplied for the generator by an Aqua Solutions® model H-40-C. One 6-pack of K hydrogen cylinders was used for back-up. Liquefied carbon dioxide was supplied in a 50-pound VGL dewar. One 50-pound G carbon dioxide cylinder was used for back up. Liquefied nitrogen was supplied in a 560-pound VGL dewar. Specifications for each gas supply vessel are described in detail in Table 5.2.

Table 5.2 Gas Supply Equipment

Description	Specification
Liquid nitrogen	VGL Dewar, 560 pounds with 24,350 CF gas capacity
Liquid carbon dioxide	VGL Dewar, 50 pounds with 3,347 CF gas capacity
Hydrogen generator	Proton Energy Systems HOGEN® S40 generator
Compressed carbon dioxide	One backup G cylinder, 50 pounds with 412 CF of gas capacity
Compressed hydrogen	One backup 6-pack of K cylinders, 120 pounds with 1,314 CF of gas capacity

MBfR Vessel Skid

The MBfR technology was APTwater's NSF 61 certified AroNite™ biochemical reduction system for autotrophic reduction of nitrate and perchlorate. There were two MBfR vessels (T-100 and T-200) operated in a lead/lag configuration. Each vessel was a 575-gallon open-top, flat bottom, 42-inch diameter and 96-inch tall polyethylene tank. Each vessel contained seven membrane modules, for a total of 14 modules. Each module consisted of thousands of parallel hollow-fiber polypropylene membranes that were woven together using solid polyester fibers to form sheets. The sheets were wrapped around a perforated acrylonitrile butadiene styrene (ABS) core to form hundreds of sheet layers. Water flowed from the center of the perforated ABS core radially outward and perpendicular to the hollow-fiber membrane sheets. The sheets were connected to the top and bottom of each reactor to epoxy heads. The top of each reactor was flush with the end of the epoxy head, and the fibers were connected to a ¼-inch stainless steel fitting that was pressurized with hydrogen. This allowed hydrogen gas to enter the lumen of each hollow fiber from the top of the module. The rate of hydrogen gas transfer was controlled by the rate of hydrogen depletion outside of the membrane. Pure hydrogen was present in the lumen, and hydrogen diffusion through the membrane was controlled by the concentration gradient on the membrane exterior. As bacteria in the biofilm consume hydrogen on the outside surface of the membrane, a hydrogen concentration gradient is established, which increases the flow rate of hydrogen across the membrane. The faster that bacteria consume hydrogen, the faster the hydrogen will permeate from the lumen to the exterior surface. Nitrate- and perchlorate-contaminated water flowed across the outside of the hollow fiber membranes and indigenous organisms colonized the exterior fiber surface. The bubble-less gas transfer across the membrane to the bacteria allowed for maximum electron donor utilization. The total surface area for the 14 modules was 2,000 m².

While the system was operated in a lead/lag configuration, a three-way valve was installed to allow the PLC to switch between the two vessels as the lead or lag position. The purpose of switching vessel positions was to maintain similar active growth of biomass in both vessels. If the configuration was left constant, the lead vessel would receive the bulk of nutrients. The lag

reactor may also develop a population of sulfate-reducing bacteria if hydrogen is over-fed and/or other electron acceptors such as oxygen, nitrate, and perchlorate are under-fed. Another possible benefit to switching lead/lag positions was that if sulfate-reducing bacteria developed while in the lag position, higher concentrations of DO present in the influent water would inhibit their growth once switched to the lead position. The frequency of position change was every 96 hours. As described in the research report by ASU (Rittmann et al. 2013), the sulfate-reducing bacteria still persisted even though this strategy was used.

An Ebara 3U 65-160/10 recirculation pump was installed in each MBfR vessel (P-100 and P-200), and each had an adjustable flow rate of 70 to 280 gpm. The recirculation pump was installed to provide mixing and increase mass transfer efficiency of contaminants to the biofilm inside the modules. The module fibers were periodically sparged with nitrogen to control biofilm formation. Water was drained from the reactors using a Goulds 1ST drain pump (P-101). The frequency of sparging was controlled by the PLC and was based on maintaining constant discharge pressure on each vessel. The sparge was conducted by draining the vessel to 22 percent of its capacity and then sparging with nitrogen gas at 10 standard cubic feet per minute (SCFM) for 1 minute. The vessel was emptied, refilled to 22 percent capacity, and sparged a second time at 1 SCFM. This water was then purged, the vessel refilled to full capacity, which completed the sparge process. For approximately one month during Optimization testing, compressed air was used in place of nitrogen for sparging. Phosphorous supplementation was added to the treatment line upstream of the lead MBfR vessel. NF certified phosphoric acid was dosed from a 5-gallon tank (T-180) using a Pulsafeeder Pulsatron E Plus Series diaphragm metering pump (P-180). The rate of phosphorous supplementation was targeted to attain a residual concentration of approximately 0.5 mg/L in the lead MBfR reactor influent.

Five side-reactors were installed with each MBfR vessel (Figure 5.7a). These side-reactors were comprised of the same material as the main reactor and used for biofilm sampling. A slipstream of water from the main reactor was circulated through the side reactors. A side-reactor was harvested from the lead and the lag vessels at the end of each phase (Start-Up, Optimization, Steady State, and Challenge) and then sent to ASU for analysis (Rittmann et al. 2013). The side reactors contained the membrane fabric within a 4-inch by 3-inch space within the interior of a 6-inch-by-6-inch square polycarbonate unit. The polycarbonate unit was housed in a 6-inch by 10-inch polycarbonate container. The surface area of the membrane was approximately 35.6 square inches (230 square centimeters).

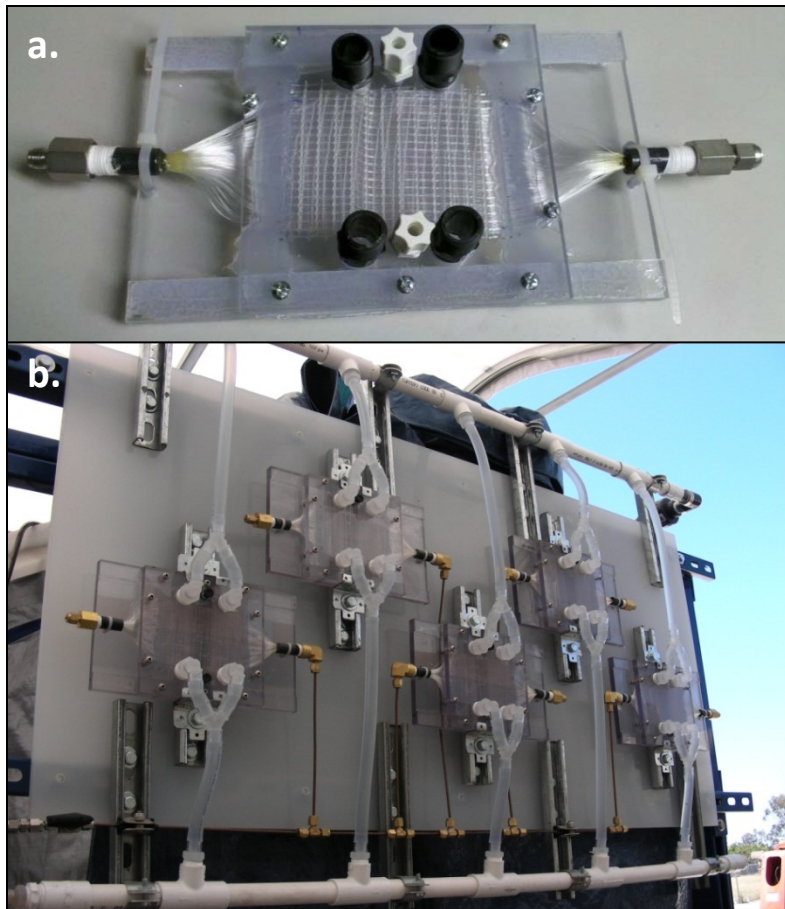

Figure 5.7 MBfR Vessel Side-Reactors Prior to Installation (a) and After Installation (b)

Aeration tank

The aeration tank was a 350-gallon polyethylene tank (T-500). Air was sparged through the bottom of the tank using a small Danner AP-100 air compressor and a 7-inch round, 1.5-inch thick aeration stone in the bottom of the tank (ClearWater™ Air Stone CWAS-FF41C) rated at 1.5 cubic feet per minute (CFM). Water was pumped from the aeration tank to the media filter using a Goulds 1ST 1.5 horsepower pump (P-502). A small percentage of the aeration tank effluent flow (approximately 1 gpm) was routed to the sump tank via an overflow weir rather than fed to the media filter by setting the media filter flow slightly less than the MBfR feed flow. The purpose of splitting the flow was to maintain constant hydraulic head in the aeration tank.

Media filter

Two parallel 21-inch diameter and 62-inch tall fiberglass tanks were used for the media filters (M-510A/B). However, only one filter was operated at a given time. Each tank contained 7.5 cubic feet or 36-inches of Next-Sand filtration media (14 x 40 mesh clinoptilolite aluminosilicate) with 2 cubic feet of ¼ x ⅛ inch support stone. The filter was backwashed using a Goulds 2ST 3 horsepower pump (P-514). Water from the product tank was used for backwashing at a rate of 48 gpm [approximately 22 gallons per minute per square foot (gpm/ft²)] for 10 to 13 minutes. Backwashes were triggered when the pressure differential across the filter was in excess of 10 pounds per square inch (psi). Two Kinetico Hydrus multi-tank automatic backwash valves with backwash control with a Kinetico Hydrus Smart Start Controller were

used with the PLC for timed backwash control. Backwash water was collected in a 950-gallon break tank. On day 125, the last day of Start-Up, a filter aid began being used at the influent of the media filter to increase filter removal efficiency and decrease effluent turbidity. The filter aid was an NSF 60 Sterling Water Technologies aluminum chlorohydrate (SWT-8806A). This was changed to aluminum chlorohydrate SWT-2000 on day 173. The filter aid was stored in one 5-gallon tank (T-501) and was added to the system using a Masterflex L/S pump (P-501).

Finished Water Tank

NSF 60 sodium hypochlorite was added to the media filter effluent water for disinfection using an Iwaki America Inc. E-Class metering pump (P-515) prior to entering the product tank. The chlorine dose was calculated based on CT requirements and chlorine demand tests (see Section 5.6). The sodium hypochlorite tank was a 25-gallon NSF60 hypochlorite tank (T-516). Finished water, or product water, was stored in a 1,000-gallon (T-518) polyethylene tank that was 64 inches in diameter and 81 inches tall.

Break Tank and Sump

The break (reject) tank was used as a temporary storage container for media filter backwash water. This was a 950-gallon polyethylene tank. Water from the reject tank and product tank were pumped to the sump prior to GAC treatment. The sump tank was a 400-gallon polyethylene tank (T-601) with a Goulds 1ST sump pump (P-600).

Granular Activated Carbon (GAC) Filtration

Two Carbon Supply Inc. L-1000 steel vessels were installed in a lead/lag configuration. The vessels were 36 inches in diameter and 77 inches high. The vessels contained 1,000 pounds of F300 8 x 30 mesh GAC for removal of VOCs in compliance with RWQCB permit requirements. Two parallel in-line bag filters were installed upstream of the GAC vessels for turbidity and solids removal. The solids retained by the filters were primarily associated with detached biofilm.

Ion Exchange (IX) Resin

Two Calgon TW-36 vessels were installed in a lead/lag configuration. The vessels were each filled with 36 cubic feet or approximately 2,300 pounds of CalRes 2109 IX resin. The vessels were 42 inches in diameter and 67 inches high. The vessels were installed with IX resin to remove residual perchlorate in compliance with RWQCB permit requirements.

Groundwater Discharge

The effluent of the IX resin treatment was discharged to an existing French drain under California RWQCB permit number R8-2002-0033-038.

Monitoring through each stage of the process was conducted at the sampling locations identified in Table 5.3. Specific details on the sampling protocol for each Phase are outlined in Section 5.6.

Table 5.3 Sample Port Locations

Sample Port	Description
SP-001	MBfR influent
Strainer	Post phosphate injection, prior to MBfR1
SP-100	MBfR1 effluent
SP-200	MBfR2 effluent
SP-500	Aeration tank effluent
SP-506	Filter backwash
SP-507	Media filter effluent
Post-NaOCl	Post sodium hypochlorite injection, prior to product tank
SP-508	Product tank (finished water) effluent
SP-600	MBfR solids drain
SP-801	GAC 1 effluent
SP-802	GAC 2 effluent
SP-803	IX 1 effluent
SP-800	Permitted outfall

5.4.2 Online Monitoring and Control

Operator Interface Terminal (OIT) System/Programmable Logic Controller (PLC)

The PLC uses software to control a wide variety of operating parameters and is controlled by a touch screen OIT [commonly called a human machine interface (HMI)]. The OIT was used to control system operations, track parameters, and check and control system processes (Figure 5.8). An Allen-Bradley PLC was used to control the treatment system. System interlock alarm responses are shown in Table 5.4.

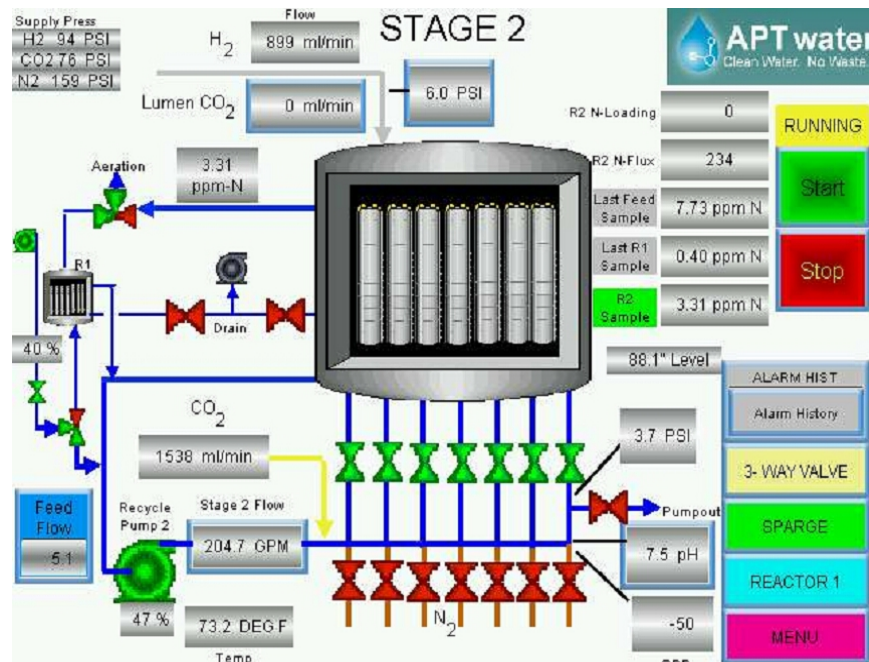

Figure 5.8 OIT System Monitoring Screen for the Lag MBfR

Table 5.4 System Interlock Alarm Responses

Alarm Description	Computer Action	Operator Response
E-Stop	Shuts down all valves, pumps, and gas flows.	If the E-Stop button is pushed accidentally, pull out the E-Stop button to reset it and acknowledge the alarm.
Remote Shutdown	Shuts down all valves, pumps, and gas flows. If the well pump is not running, the MBfR receives a shutdown signal.	Resolve the remote shutdown signal, acknowledge the alarm, and restart the system.
High Hydrogen Pressure	Closes all hydrogen valves.	Investigate reason for high pressure, such as a failed regulator or hydrogen control valve.
High Temperature	Shuts down the valves, pump, and gas flows to the stage with the high temperature to prevent overheating the pumps or the biomass.	Determine the cause of the high temperature. Consider reducing the recycle flow rate set point for that unit in order to minimize heat input [so the Variable frequency drive (VFD) will run slower].
High Differential Pressure	Alarm only.	Consider adjusting sparge settings to reduce the pressure buildup. Consult APTwater when making adjustments.
Low Water Flow	Shuts down all valves, pumps and gas flows for that stage. This alarm protects the pump from dead heading, which can lead to premature failure.	Determine the cause of the low water flow.
LEL (hydrogen leak) Detection	LEL detector will shut down all hydrogen valves.	Stop any hot work (electrical, drilling, cars, welding, etc.) and look for hydrogen leaks and repair.
VFD Failure	Each stage will shut down on low flow.	Ensure that the circuit breaker is ON. Refer to the VFD manual for troubleshooting the VFD.
Water Flow Deviation from setpoint	Warning only.	Determine why water flow is not at setpoint (plugged feed filter, high differential pressure in modules, feed regulator pressure set too high/low, flow setpoint incorrect, etc.).

Alarm Description	Computer Action	Operator Response
pH High	Warning only. High pH can lead to Hardness pH in the feed water precipitating out, which will cause plugging if allowed to continue.	Check the CO ₂ cylinders. High pH indicates that the CO ₂ gas flow may not be working. Verify that all valves are open between the cylinder and the MBfR. Open the appropriate pH Control screen and verify that the controller is in Auto and that there is CO ₂ flow and the setpoint for pH is 7.2 SU. Open the Mass Flow Controller cabinet and see if the readout on the screen shows a CO ₂ flow.
pH Low	Warning only. Low pH can cause the bacteria to perform less than optimal. Very low pH water is also more corrosive.	Follow the same steps as for High pH. Consider lowering the CO ₂ regulator pressure and the maximum CO ₂ flow to help avoid adding too much CO ₂ .
Sparge Timeout	System exits sparge cycle.	Resolve the cause of a long sparge.

Nitrate Analyzer

Nitrate analyzers were supplied by Endress and Hauser (Reinach, Switzerland). In the beginning of the project, the Stamosens CNM750/CNS70 nitrate analysis system was used, with a nitrate-N detection range of 0.2 to 60 mg/L. This analyzer was replaced on day 88 with a Liquiline CM44x controller and a Viomax CAS51D sensor. This sensor had a nitrate-N detection range of 0.01 to 10 mg/L. An automated Asahi Electromni electrically actuated ball valve was placed upstream of the nitrate analyzer and switched hourly between a supply of MBfR lead effluent and lag effluent to the analyzer which allowed monitoring by the OIT system. Water from the influent to the MBfR system was analyzed by the nitrate analyzer one hour each day.

pH and ORP Probes

The pH and ORP analyzers were supplied by George Fischer Signet (El Monte, CA). The Signet DryLoc 2750 pH/ORP probe had a range of 0 to 14 pH SU and 0±2000 millivolts (mV) for ORP and was monitored by the OIT system. The analyzers were used to continuously monitor effluent pH and ORP of the MBfR lead and lag tanks. The pH analyzer was tied into the PLC to control the addition of carbon dioxide gas to maintain a consistent pH.

Turbidimeters

Turbidity analyzers were supplied by Endress and Hauser and monitored by the OIT system. The Liquisys M CUM223/253 analyzer was used to continuously monitor the effluent from the product tank. On day 166, a Turbimax CUE22 in-line analyzer was installed downstream of the media filter. The two turbidimeters were monitored for the duration of the study.

LEL/Hydrogen Detectors

Since hydrogen gas was used for an electron donor, Scott Sentinel II LEL sensors were supplied to monitor for leaks. The LEL sensor span was 0 to 100 percent. Hydrogen has a low LEL of 4

- A new concrete pad and security fence were installed to provide structural support for the gases.
- Two Conex shipping containers were installed and leveled plumb to each other. A heavy-duty canopy was installed by connecting the span of the two shipping containers.
- Secondary containment was installed for spill prevention. An additional secondary containment was installed in one of the shipping containers for spill prevention from additional treatment system components.

After the system was constructed, gas and water leaks were tested in pipelines and vessels prior to Start-Up. The first day of Start-Up was April 20, 2011. The maximum flow rate that the system was permitted to produce was 30 gpm. Table 5.5 lists initial start-up conditions and targets planned for the study. The pH in the MBfR vessels was kept relatively constant between approximately 7.0 and 7.5 SU to maximize biological activity, minimize precipitation in the biofilm, and minimize carbon dioxide consumption. NSF grade phosphoric acid was added as a nutrient supplement at a target concentration of 0.5 mg-P/L. The dose was determined based on nutrient demand for cellular growth and previous research (Brown et al. 2008).

Table 5.5 Phase I System Start-Up

Parameter	Units	Initial Value	Target	Range
Feed flow rate	gpm	1	maximum sustainable	1 to 30
Recycle flow rate in each tank	gpm	140	140	70 to 280
Hydrogen pressure	psi	5	30	5 to 30
Carbon dioxide flow rate	SCFH	7.0 to 7.5	7.0 to 7.5	3 to 20
MBfR tank lead/lag reversal time	days	3	3	-
MBfR module nitrogen sparge and tank drain frequency	hours	Off	24	12 to 96
MBfR module nitrogen sparge duration	minutes	3	1	-
Nitrogen sparge flow rate per module	SCFM	10	10	-
Media filter backwash rate	gpm	40 to 48	48	40 to 48
Media filter backwash duration	minutes	20	10-15	0 to 20
Effluent perchlorate	µg/L	Average influent of 166	< 4	< 4 to 100
Effluent nitrate	mg-N/L	Average influent of 8.6	< 0.5	0 to 2.5

Online process monitoring for the Demonstration included a combination of manually recorded monitoring parameters and online data from the supervisory control and data acquisition (SCADA) system. Monitoring data included:

- Hydrogen flow rates and cumulative volume (SCADA)
- Hydrogen pressures (SCADA)
- Tank carbon dioxide flow rates and cumulative volume (SCADA)
- Module carbon dioxide flow rates and cumulative volume (SCADA)

- Nitrogen pressure (SCADA)
- Nitrogen flow rates and cumulative volume (gauges)
- Gas supply tank pressures/levels (gauges)
- Aeration tank air flow rate and pressure (gauge)
- Cumulative volume to 2,500-gal feed tank (gauge)
- Instantaneous flow rate to 2,500-gal feed tank (gauge)
- Feed flow rate to MBfR skid (SCADA)
- Recycle flow rates (SCADA)
- Recycle pump discharge/core tube pressures (SCADA)
- Filter flow rate (SCADA)
- Backwash frequency and duration (SCADA)
- Nitrogen/air scour frequency and duration (SCADA)
- pH (SCADA)
- ORP (SCADA)
- Temperatures (SCADA)
- Nitrate (SCADA)
- Turbidity (SCADA)
- Hypochlorite flow rate and cumulative volume (graduated cylinder/stopwatch, level indicator)
- Coagulant/flocculant flow rate and cumulative volume (graduated cylinder /stopwatch, level indicator)
- Media filter inlet pressure (SCADA)
- Media filter outlet pressure (SCADA)
- Media filter backwash events (SCADA)
- Media filter backwash flow rate and volume per event (SCADA)
- Bag filter pressures (gauges)
- GAC and IX vessel pressures (gauges)
- Cumulative volume discharged to French drain (gauge)

Chlorination Disinfection Study

Disinfection of treated water was attained using NSF 60 grade sodium hypochlorite. Chlorine demand tests were conducted on days 52 and 53 using the Chemetrics test kit K-2504 (DPD colorimetric method) and following Standard Method 2350 for chlorine demand (APHA 1998). Residual free chlorine was measured after 1, 5, 60, 140, and 160 minutes as representative of the approximate hydraulic residence time between the injection point and the effluent of the product tank. Chlorine demand was evaluated to guide chlorine-dosing needs. During operations, residual chlorine was also measured at the finished water to confirm that the appropriate residual was attained.

The USEPA Ground Water Rule requires at least 99.99 percent (4-log) inactivation (disinfection) or removal (filtration) of viruses be provided by Public Water Systems using ground water that is not under the direct influence of surface water as its source. No filter credit is allowed for biological treatment systems, thus the entire 4-log inactivation/removal must be accomplished by disinfection. The USEPA “Guidance Manual for Compliance with the Filtration and Disinfection Requirements for Public Water Systems Using Surface Water Sources” (USEPA 1991) was used

as a guideline for achieving the 4-log inactivation. The CT requirement was calculated as the concentration of disinfectant “C” multiplied by the contact time “T” in minutes. The chlorine dose was altered to meet CT requirements at the finished water tank.

Tracer Test

A tracer test was conducted on day 109 to evaluate the hydraulic residence time in the MBfR reactors. There was potential for “short-circuiting” of flow that bypassed portions of the reactors. A high-concentration sodium chloride (NaCl) solution was used as a conservative tracer in the lag reactor. A 300-g/L stock solution was made with a conductivity of 459 millisiemens per centimeter (mS/cm). Conductivity measurements were collected using a Hach Sension handheld conductivity meter. Background conductivity readings were collected from the lag reactor effluent prior to adding the solution and were approximately 400 microsiemens per centimeter ($\mu\text{S/cm}$). A single pulse of salt solution was added to the siphon inlet of lag MBfR while the system was operating at 18 gpm. The lag effluent conductivity was measured every 15 minutes until conductivity declined to near baseline levels.

The key indicator of start-up success was attaining perchlorate concentrations in the effluent of the lag reactor of less than the EPA Method 314.0 analytical reporting limit of 4 $\mu\text{g/L}$. Other parameters used to assess start-up progress included concentrations of DO, nitrate, nitrite, and sulfide in the lag reactor; hydrogen consumption; ORP, and biomass accumulation on MBfR fibers.

5.5.2 Optimization

The primary goal of the Optimization phase was to identify peak operating conditions for the MBfR. This phase was designed to obtain data under a variety of operating conditions and assess the effects of operating conditions on perchlorate and nitrate removal. Previous research indicated that hydrogen pressure, which controls electron donor availability, and electron acceptor surface loading rate were key operating parameters for the MBfR (Zhao et al. 2011; Ziv-El and Rittmann 2009). Other parameters include the recycle flow rate, which affects mass transfer, MBfR gas sparge frequency, and the gas used for sparging. Table 5.6 presents conditions for the Optimization tests. The general approach was based on variation of the MBfR recycle rate and feed water flow rate. Membrane hydrogen pressure was adjusted to alter the electron donor delivery capacity to match stoichiometric requirements. Influent flow rate was varied to assess performance at various hydraulic residence times and contaminant loading rates. Recycle rate was varied to evaluate liquid-phase mass transfer resistance and associated effects on contaminant removal flux. The effect of lead/lag reversal on perchlorate and nitrate treatment was also assessed.

Table 5.6 Phase II System Optimization Tests

Start Day	End Day	Flow Rate (gpm)	Recycle Rate		Hydrogen Pressure		N Loading ($\text{mg-N/m}^2\text{d}$)	ClO_4^- Loading ($\text{mg/m}^2\text{d}$)	Sparge Rate (hrs)
			MBfR1 (gpm)	MBfR2 (gpm)	MBfR1 (psi)	MBfR2 (psi)			
127	132	15	280	280	17	19	739	12.7	24
132	140	10	280	280	12	15	493	8.5	24

Start Day	End Day	Flow Rate (gpm)	Recycle Rate		Hydrogen Pressure		N Loading (mg-N/m ² d)	ClO ₄ ⁻ Loading (mg/m ² d)	Sparge Rate (hrs)
			MBfR1 (gpm)	MBfR2 (gpm)	MBfR1 (psi)	MBfR2 (psi)			
140	141	20	280	280	20	24	986	17	24
141	146	5	280	280	20	10	246	4.2	24
146	148	15	210	180	10	15	739	12.7	6
148	151	15	210	210	10	15	739	12.7	6
151	154	10	210	180	10	13	575	9.9	6
154	155	10	180	180	15	12	575	9.9	6
155	157	10	180	180	15	12	575	9.9	12
158	162	10	180	180	15	12	575	9.9	24
162	169	5	180	180	15	12	287	5	24
169	178	10	180	180	15	12	575	9.9	24
179	182	10	180	180	15	12	575	9.9	12
182	197	10	150	180	15	15	575	9.9	12
197	202	10	150	180	15	17	575	9.9	4
202	205	10	150	180	15	15	575	9.9	4
206	209	10	150	180	15	15	575	9.9	48
209	217	8	150	120	15	15	647	11.1	12
217	217	6	150	120	16	16	517	8.9	12
217	228	6	150	120	16.5	16.5	517	8.9	12

Batch Testing

Batch tests were conducted to evaluate mass transfer limitations, determine whether reduction of perchlorate concentrations to less detection limits was possible, and determine how sulfide production correlated with perchlorate reduction. Two batch tests were conducted to systematically evaluate the effect of recycle flow rate on performance (see detailed methods in Appendix D). The first was on day 141. The influent flow was increased from 10 to 20 gpm on the day prior to the test until the nitrate analyzer readings were above 5.5 mg-N/L in the lead reactor effluent. On the day of the test, the influent and effluent lines were closed on the lead vessel. The recycle pump was operated at a rate of 280 gpm and the hydrogen pressure was 28 psig. The nitrate analyzer was monitored online at the lead vessel and at the discharge of the recycle pump. Samples were collected when the online nitrate analyzer reading was 2.5, 0.5, and 0 mg-N/L. Samples were also collected after 5, 10, and 20 minutes of attaining 0 mg-N/L in the reactor. The same protocol was followed for the lag vessel except the hydrogen pressure was 20 psig. The samples were sent an analytical laboratory for perchlorate, sulfate, and sulfide analyses.

The second batch test was conducted on days 200 and 202. These tests were conducted to assess the effect of varying recycle flow rates on nitrate and perchlorate removal. On the day prior to the test (day 119), influent flow was 10 gpm and the recirculation flow rate was 180 gpm on MBfR2 and 150 gpm on MBfR1. The two vessels had different recycle ratios because MBfR1

had 4 modules and MBfR2 had 6 modules. The lead vessel (MBfR2) had a hydrogen pressure of 17.5 psi, and the lag vessel (MBfR1) was 15 psig.

Single-Stage Operation

The system was designed to operate in series, in a lead/lag configuration. On day 143, the flow was decreased from 10 to 5 gpm and the lag reactor was bypassed to simulate single-stage operation. The nitrate analyzer was monitored online and water samples were collected on day 144 at the influent and effluent of the lead reactor for perchlorate, nitrate, and nitrite to assess performance. Total sulfide and sulfate were collected from the aeration tank to assess the impact of sulfate-reducing bacteria. The vessels were placed back on a lead/lag configuration at the end of day 144.

System Upsets

System upsets including module failures, leaks, level alarms, and loss of hydrogen supply occurred during Optimization (Table 5.7). Each vessel initially had seven membrane modules. Several modules had mechanical failures due to delamination of the epoxy head from the reactor core, which was likely associated with manufacturing issues that have since been remedied. On day 146, failure of the O-ring seal at the bottom of the reactors resulted in hydrogen bypass. The design was changed to a screw-mount rather than O-ring connection to mitigate further bypass. The reactors were exposed to air during these maintenance activities for approximately 19 hours.

Table 5.7 System Upset Conditions

Start Day	End Day	Upset Condition					Reactors Online	
		System Down	O-ring Bypass	Reactor Failure	Hydrogen Leak	No Hydrogen Supply	MBfR 1	MBfR 2
146	146	X	X				7	7
150	153	X		X	X		6	6
169	169	X		X			5	6
182	183	X		X			4	6
205	207	X		X			4	4
217	217	X					4	4
220	220					X	4	4
228	229	X					4	4

Sparging

Compressed air was used in place of nitrogen for sparging on days 168 to 191 to test effects on performance. Since the reactors are targeting anoxic bio-reduction, nitrogen gas was normally used for sparging. The duration of the compressed air sparging was 1 minute at 10 SCFM and the tested frequencies were once every 48, 24, 22, 12, 6, and 4 hours.

5.5.3 Steady State

Steady State operation was conducted from days 230 to 258 to assess performance, stability, and responsiveness to normal fluctuations in water quality. The system was operated at conditions determined during Optimization that produced the best performance with respect to perchlorate

and nitrate removal. Disinfection was assessed by maintaining appropriate disinfectant contact time and residual to meet CT requirements. Finished water quality and aesthetics were assessed including turbidity, DBPs, DBP-FP, nitrosamines, DOC, and TON.

5.5.4 Challenge

The primary goal of the Challenge phase was to perturb MBfR operation sufficiently to temporarily disrupt perchlorate and nitrate removal and then monitor response to baseline operations. Hydrogen shutoff simulated loss of electron donor. System shutdown tests simulated power failure and shutdown of all operations (Table 5.8). System monitoring and sampling was conducted when the system was placed back online until conditions rebounded to baseline conditions. Maintenance activities conducted during Optimization provided information on system resiliency and reliability (see Section 5.5.2), and were therefore not evaluated further.

Table 5.8 Phase IV System Challenge Tests

Test	Test Description	Challenge Duration
1	Hydrogen shutoff	4 hours
2	Hydrogen shutoff	24 hours
3	System Shutdown	4 hours
4	System Shutdown	24 hours

5.5.5 Backwash Water Characterization

Membrane fibers were gas sparged to control accumulation of inert compounds and biofilm growth on the exterior surface of the membrane fibers. The frequency of sparging was controlled by the PLC and was selected to maintain a relatively constant reactor discharge pressure, which was affected by biomass and solids accumulation on the membranes. The frequency of sparge events was varied throughout the project over the range of once every 48, 24, 12, 6, and 4 hours. The sparge process included draining the lag vessel by approximately 78 percent, sparging with nitrogen gas for one minute at 10 SCFM, and draining the vessel to approximately 3.2 percent full. The vessel drainage period was 2 to 4 minutes. Sparge samples were collected as a 3-point composite from 0.5, 1.5, and 2.5 minutes after draining. The vessel was then partially filled to 22 percent of capacity, water was recirculated at 30 gpm for one minute, and the vessel was drained a second time. The total time that the fibers were exposed to air was about 10 minutes and did not result in drying of the biofilm. The biofilm was exposed to air during this time. However the nitrate- and perchlorate-reducing bacteria are facultative and are not killed by exposure to oxygen. A separate composited sample of this drain water was also collected. This process was conducted individually for the lead and lag vessels. Samples were analyzed in an analytical laboratory for TSS. Turbidity measurements were analyzed initially using a Hach 2100P turbidimeter until it was replaced by a more sensitive Hach 2100N on day 188.

The media filter was backwashed when the pressure differential across the filter was in excess of 10 psi. Manual backwashes were initiated for sampling when the differential pressure across the filter was close to the backwash set point. Water from the product tank was used for backwashing at a rate of 45 to 50 gpm (21 to 23 gpm/ft²) for 10 to 13 minutes. The entire backwash process used approximately 400 to 500 gallons of water. Five 200-mL samples were

collected at 1, 3, 5, 7, and 9 minutes and composited. Samples were analyzed in an analytical laboratory for TSS using Standard Method 2540D (APHA 1998). Turbidity measurements were conducted in the field using a Hach 2100 P turbidimeter until it was replaced by a Hach 2100N on day 188.

5.5.6 Demobilization

Demobilization activities included:

- Gas injection, phosphorus supplementation, and disinfection injection systems were disassembled.
- The system was drained, flushed with well water, and drained again.
- The influent tank, MBfR vessels, aeration tank, media filter, product tank, GAC and IX vessels, and piping were disassembled.
- Secondary containment infrastructure was removed.
- Electrical power was disconnected and terminated by an electrician.
- GAC and IX resin were characterized and disposed.
- The influent well electrical panel, cabinets, power and control wiring were left in place and the piping to the system was removed.
- The outfall discharge French drain was capped.
- Remaining chemicals and field test kits were removed from the site.
- The gas canisters, carbon dioxide, and nitrogen tanks were removed from the site.
- The Conex trailers, associated equipment, and canopy were removed off-site.
- Lab waste was disposed as hazardous waste off-site.
- The GAC and IX vessels were removed from the site.

5.6 SAMPLING METHODS

This section describes the sampling locations, collection procedures, and analysis methods performed during the MBfR Demonstration project. The primary sampling locations included the influent groundwater (MBfR influent), MBfR lead and lag effluents, and the post-aeration, treatment process (i.e., media filter, bag filter, GAC, and IX) effluents. QA/QC results are summarized in Appendix E.

5.6.1 Analytical/Testing Methods

Table 5.9 lists the parameters tested, sampling locations, and frequency of collection during the Demonstration. Most of the samples were grab samples, except for the MBfR sparge and filter backwash samples, where composites were collected (Appendix D). Test America (Irvine, CA) performed the off-site laboratory analysis and was certified by the California Environmental Laboratory Accreditation Program. Sulfide, nitrate, nitrite, DO, and chlorine residual were measured in the field using test kits. Temperature, ORP, turbidity, and pH were measured using hand-held probes. On-line monitoring data were also collected continuously through the OIT for nitrate, pH, ORP, and temperature. The sampling frequency varied between once a week to three times a week depending on the parameter and phase of the Demonstration.

5.6.2 Sample Collection

Sample bottle size, type, and preservative are shown in Table 5.10. Sample bottles were completely filled, capped with no headspace, and stored in an on-site refrigerator or coolers at less than 4°C after collection. Coolers were kept out of direct sunlight as much as possible. A chain-of-custody (COC) form, sealed in a plastic bag to protect it from water, was placed inside the cooler. Samples were submitted to the laboratory within one day of sampling. The QAPP provides a more in-depth discussion of sample documentation procedures. For on-site water quality analysis, probes and field test-kits were used. Field monitoring equipment were calibrated at the beginning of each field day and recorded on the field log (Appendix B). For the off-site laboratory analysis, the selected methods represented standard USEPA procedures or modifications of these procedures for the analytes of concern.

Table 5.9 Sample Collection Frequency

Analyte	Samples/Week			Location
	Start-Up	Optimization	Steady State	
<i>Laboratory Analyses</i>				
Perchlorate	3	3	3	Influent
	6	6	6	MBfR
		3	3	Finished Water
Perchlorate (Confirmatory)		1		Influent
	2	4	1	MBfR
		1		Finished Water
Nitrate and Nitrite	1	1	1	Influent
	2	2	2	MBfR
			1	Finished Water
TCE, cis-1,2- DCE, and VC	1	1	1	Influent
	2	2	2	MBfR
	1	1	1	Post MBfR
TSS	1*	1*	1*	MBfR Sparge
	2	2	2	Post MBfR
	1*	1*	1*	Media Filter Backwash
TON			3	Finished Water
Fecal/Total Coliforms, <i>E.</i> <i>coli</i> , HPCs	1	1	1	MBfR
	2	2	2	Post MBfR
	1	1	1	Finished Water
DOC	1	1	1	Influent
	1	1	1	MBfR
	2	2	2	Post MBfR
	1	1	1	Finished Water
HAAs			1	Influent
	1	1	3	Finished Water
THM-FP			3	Finished Water

Analyte	Samples/Week			Location
	Start-Up	Optimization	Steady State	
THMs	1	1	2	Finished Water
Nitrosamines			1	Finished Water
Sulfate	1	1	1	Influent
Total Sulfide	1	1	1	MBfR
		1	1	Post MBfR
		1	1	Finished Water
Alkalinity	1	1	1	Influent
	2	2	2	MBfR
TDS	1	1	1	Influent
	2	2	2	MBfR
Phosphate	1			Influent
Ammonia	1	1	1	Influent
	1	1	1	MBfR
Hardness	1	1	1	Influent
	2	2	2	MBfR
<i>Field Analyses</i>				
Nitrate and Nitrite	3	3	3	Influent
	6	6	6	MBfR
	3	3	3	Finished Water
Sulfide	3	3	3	Influent
	6	6	6	MBfR
	3	3	3	Post MBfR
	3	3	3	Finished Water
Turbidity	3	3	3	Influent
	1*	1*	1*	MBfR Sparge
	6	6	6	Post MBfR
	1*	1*	1*	Media Filter Backwash
	3	3	3	Finished Water
pH, Temperature, ORP, DO	3	3	3	Influent
	6	6	6	MBfR Sparge
	6	6	6	Post MBfR
	3	3	3	Finished Water
Chlorine	3	3	3	Finished Water

* Samples were collected approximately once per week.

Notes: Additional samples were collected for specific monitoring and permit compliance purposes. MBfR includes MBfR lead and lag effluent. Post MBfR includes the aeration tank and media filter.

Table 5.10 Analytical Methods

Analyte	Bottle	Preservative	Holding Time	Method	Type	PQL
Perchlorate	500 mL poly	4°C	28 d	EPA 314.0	Lab	4 µg/L
Perchlorate (Confirmatory)	125 mL sterile poly	4°C	28 d	EPA 332.0	Lab	0.2 µg/L
Chlorite/chlorate	125 mL brown poly	4°C, EDA	14 d	EPA 300.1	Lab	10 µg/L
Nitrate	500 mL poly	4°C	48 h	EPA 300.0	Lab	0.1 mg-N/L
Nitrite	500 mL poly	4°C	48 h	EPA 300.0	Lab	0.1 mg-N/L
Turbidity	1 L poly	4°C	24 h	EPA 180.1	Lab	1 NTU
TSS	500 mL poly	4°C	7 d	SM 2540D	Lab	10 mg/L
TON	500 mL glass	4°C	24 h	SM 140.1	Lab	NA
Fecal Coliforms	100 mL sterile poly	4°C, Na ₂ S ₂ O ₃	6 h	SM 9221E	Lab	1/100 mL
Total Coliforms				SM 9221B	Lab	1/100 mL
HPC	100 mL sterile poly	4°C	24 h	SM 9215	Lab	1/mL
DOC	250 mL glass	4°C	28 d	SM 5310C	Lab	0.2 µg/L
TCE, cis-1,2 dichloroethene (cis-1,2 DCE), vinyl chloride (VC)	3x40 mL VOAs	HCl, 4°C	14 d	EPA 8260B	Lab	1 µg/L
VOCs	3x40 mL VOAs	HCl, 4°C	14 d	EPA 8260B	Lab	Varies
THMs	2x40 mL VOAs	4°C, Na ₂ S ₂ O ₃	14 d	EPA 524.2	Lab	1 µg/L
Sulfate	500 mL poly	4°C	28 d	EPA 300.0	Lab	0.5 mg/L
Total Sulfide	500 mL poly	ZnAc ₂ & NaOH	7 d	SM 4500-S-C,D	Lab	0.1 mg/L
Alkalinity	500 mL poly	4°C	14 d	SM 2320B	Lab	10 mg/L
Total dissolved solids (TDS)	500 mL poly	4°C	7 d	SM 2540C	Lab	10 mg/L
HAAs	3x60 mL VOAs	4°C, NH ₄ Cl, agitate for 1 min	14 d	EPA 552.2	Lab	1 µg/L
Ethylene Dibromide	3x40 mL VOAs	4°C, Na ₂ S ₂ O ₃	14 d	EPA 504	Lab	0.02 µg/L
Chloride	500 mL poly	4°C	28 d	EPA 300.0	Lab	0.5 mg/L
Phosphate	500 mL poly	4°C	48 h	EPA 300.0	Lab	0.1 mg/L
Ammonia	500 mL poly	4°C, H ₂ SO ₄	28 d	SM 4500NH3-D	Lab	0.5 mg-N/L
Hardness	500 mL poly	4°C, HNO ₃	180 d	SM 2340B	Lab	10 mg/L

Analyte	Bottle	Preservative	Holding Time	Method	Type	PQL
DBP-FP	500 mL glass	4°C	14 d	SM 5710B/EPA 524.2	Lab	0.5 µg/L
Nitrosamines	500 mL poly	4°C	7 d	EPA 3520C/1625	Lab	75 ng/L
Sulfide	NA	NA	NA	Chemetrics test kit K-9510	Field	0.05 mg/L
Nitrate	NA	NA	NA	Chemetrics test kit K-6905	Field	0.1 mg-N/L
Nitrite	NA	NA	NA	Chemetrics test kit K-7002	Field	0.025 mg-N/L
DO	NA	NA	NA	Chemetrics test kit K-7512 (high) K-7501 (low)	Field	1 mg/L - high, 0.025 mg/L - low
Chlorine	NA	NA	NA	Chemetrics test kit K-2504	Field	0.1 mg/L
Phosphate	NA	NA	NA	Chemetrics test kit K-8510	Field	0.05 mg/L
pH, temperature, ORP	NA	NA	NA	Oakton pH 6+ pH probe	Field	0.01 SU, 0.1°C, 1 mV
Turbidity	NA	NA	NA	EPA Method 180.1, Hach 2100 N and 2100P Turbidimeter	Field	0.01 NTU

Note: Standard Methods followed (APHA 1998).

EDA – ethylenediamine

Na₂S₂O₃ – sodium thiosulfate

HCl – hydrochloric acid

NH₄Cl – ammonium chloride

H₂SO₄ - sulfuric acid

ZnAc₂ – zinc acetate

HNO₃- nitric acid

Challenge phase testing involved intentionally creating an upset condition and monitoring system performance after the upset. Upset conditions included shutting off either hydrogen or the entire system for a period of either 4 or 24 hours. Grab samples of the finished water were collected for perchlorate, nitrate, and nitrite before the upset, then hourly for 10 hours.

5.7 SAMPLING RESULTS

This section summarizes the results of the Demonstration. See Appendix F for the laboratory analytical data results and Appendix G for raw online monitoring data.

5.7.1 Start-Up

The purpose of Start-Up was to develop a biofilm on the membranes and demonstrate removal of perchlorate and nitrate. Start-Up lasted from day 0 to day 112. Success during Start-Up was assessed by visual inspection of the 14 membrane modules for biomass development, when perchlorate was below 4 $\mu\text{g/L}$, and when nitrate was below 0.5 mg-N/L . The system was initially operated at 5 gpm , and the MBfR effluent perchlorate concentrations were 4.5 $\mu\text{g/L}$ and nitrate was 0.25 mg-N/L by day 8 (Figure 5.10b and Figure 5.11b). The flow rate was steadily increased and effluent perchlorate and nitrate concentrations increased. The phosphate amendment system provided inconsistent delivery of nutrient until day 53, as the process was being optimized. Shortly thereafter, perchlorate and nitrate concentrations began to decrease while the influent flow rate was held constant at 12 gpm . Perchlorate was reduced from 140 to 11 $\mu\text{g/L}$ (Figure 5.10a), and nitrate decreased from 49 mg-N/L to 0.25 mg-N/L (Figure 5.11a) within a week after the phosphate amendment system was fixed. The flow rate was steadily increased again and the system initially responded with higher effluent perchlorate concentrations but stabilized at approximately 10 $\mu\text{g/L}$ within a few weeks, even when flow rates were increased to 22 gpm .

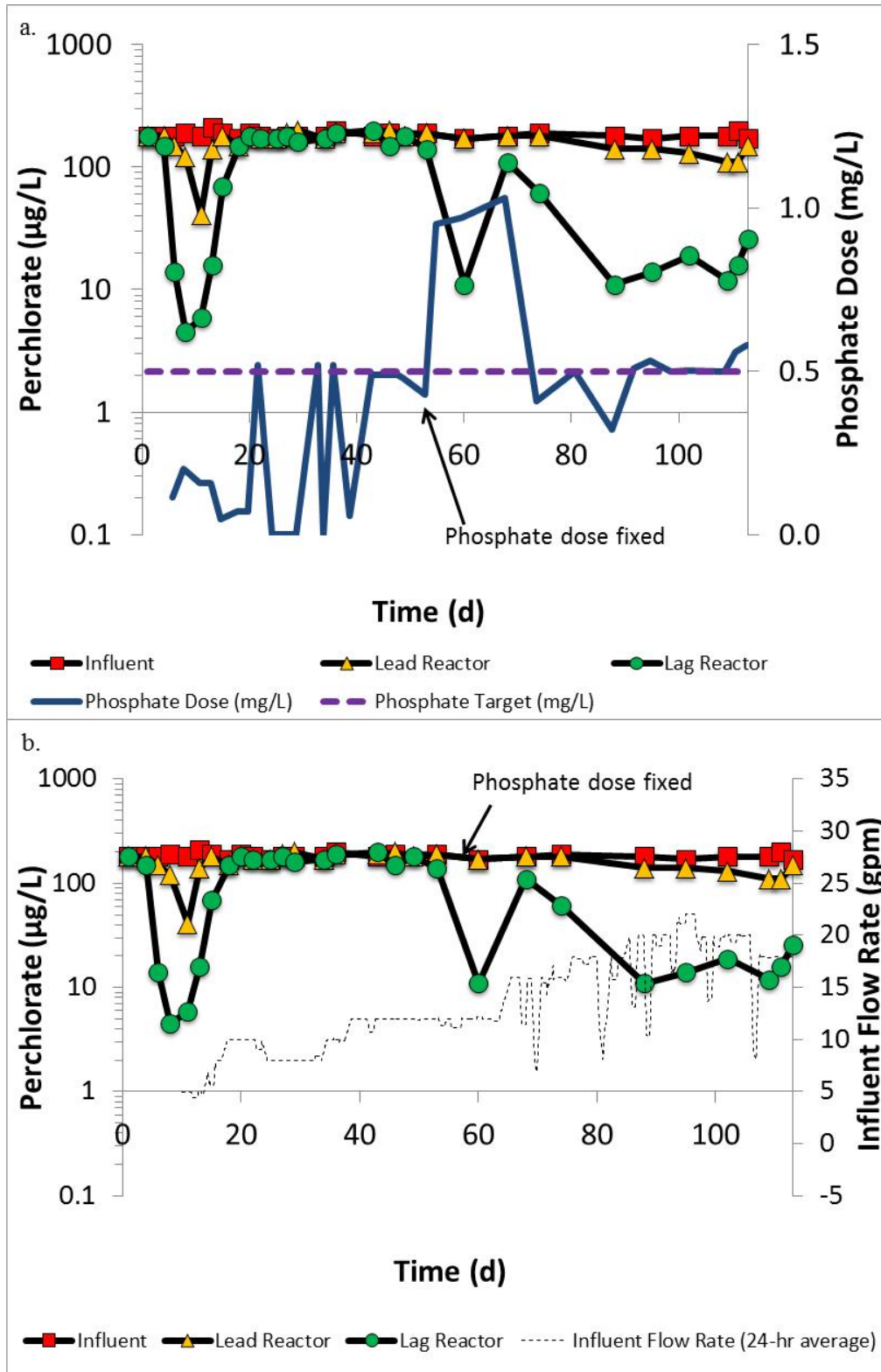

Figure 5.10 Start-Up Perchlorate and Phosphate Dose (a) and Influent Flow Rate (b)

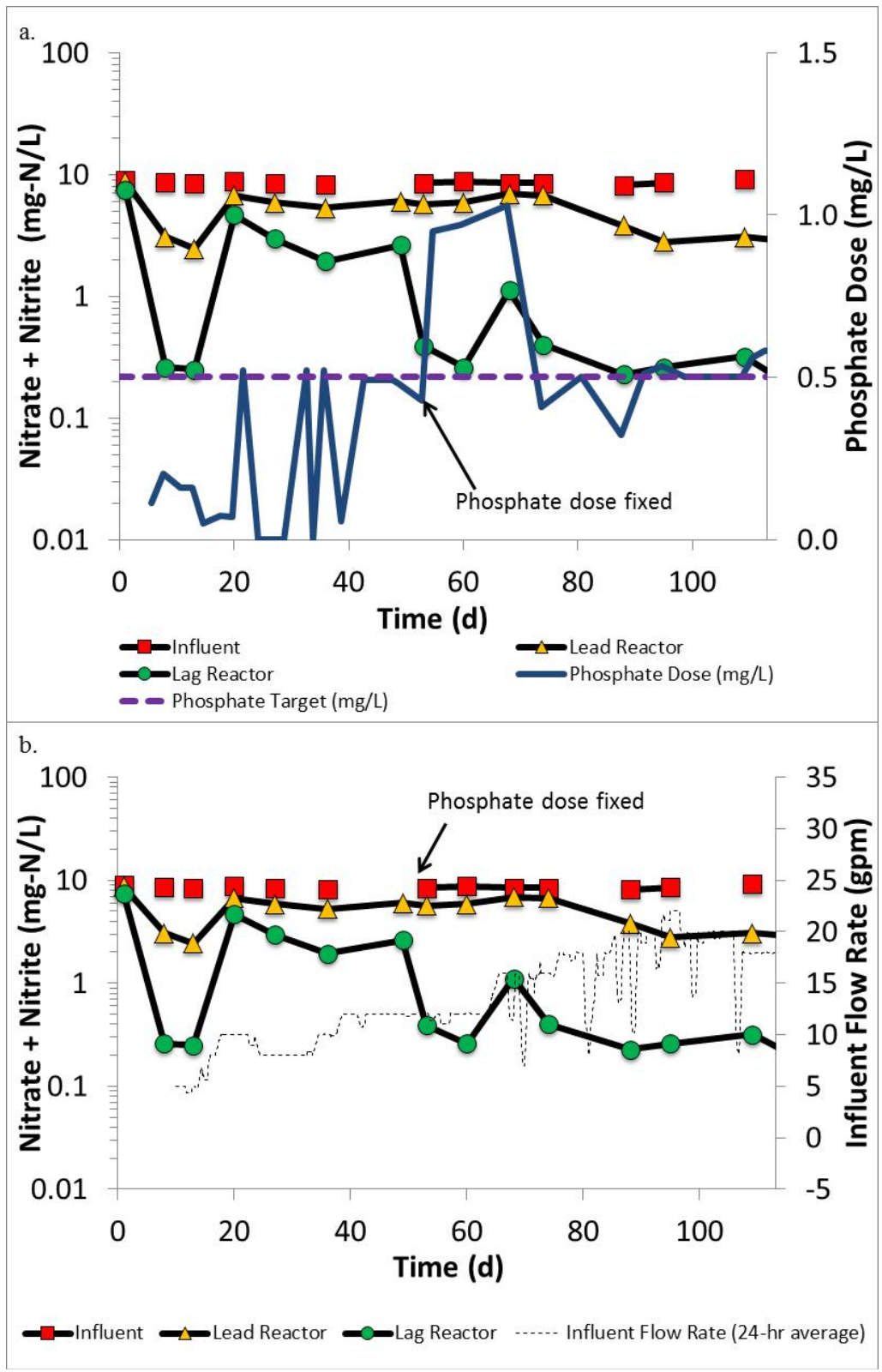

Figure 5.11 Start-Up Total Nitrogen and Phosphate Dose (a) and Influent Flow Rate (b)

Disinfectant Dose Assessment

Chlorine dose was determined based on CT requirements for a 4-log reduction for virus removal. The “C” value represents the concentration of the disinfectant (free chlorine in this case). The “T” value of the CT calculation represents the hydraulic residence time of the finished water tank multiplied by a baffling factor. A maximum flow of 5 gpm and a baffling factor of 0.1 (unbaffled) were used to develop a worst case “T” value of 20 minutes in the 1,000-gallon finished water tank. CT requirements were determined using the worst case scenario of a pH of 8 SU and a water temperature of 15°C (USEPA 2003). Under these worst-case conditions, a minimum of 0.2 mg/L chlorine residual was required in finished water for a 4-log inactivation (CT requirement of 4 mg-min/L). As the influent flow rate varied, the “T” value was adjusted accordingly resulting in different required “C” values. The chlorine dose was adjusted as needed to maintain the minimum required CT throughout the Demonstration. For example, at the maximum flow of 22 gpm, the chlorine residual needed to meet CT requirements was 0.9 mg/L.

On day 49 samples from the finished water tank were collected to determine the chlorine demand after contact times of 1, 5, 60, 140, and 160 minutes. The demand after one minute was 0.8 mg/L, while all contact times of 5 minutes or greater were 5.7 mg/L. The hydraulic residence time in the finished water tank varied depending on the flow rate from 45 minutes to 3 hours. Variations in water quality including temperature and concentrations of DOC, sulfate, sulfide, and turbidity can affect the actual chlorine demand at any particular point in time. As such, the chlorine residual was monitored at the finished water effluent three times per week.

Tracer Test

A tracer test was used on the lag MBfR to determine the residence time and flow dispersion. The test was conducted on day 109 using a concentrated salt solution. The influent flow rate was 18 gpm and the approximate volume of water in the lag reactor was 270 gallons. The MBfR lab effluent conductivity readings increased immediately after addition of the salt pulse and was back to baseline conditions approximately 90 minutes later (Figure 5.12). The recycle flow rate was 209 gpm, which was much greater than the feed flow rate of 18 gpm and effectively made the MBfR a continuous stirred tank reactor (CSTR). The actual average hydraulic residence time was 19 minutes, compared to a theoretical hydraulic residence time of 15 minutes if only advection is considered. The conductivity curve had a long tail at the end indicative of high dispersion, consistent with CSTR behavior. The Péclet number measures the ratio of the mass fluxes caused by advection and diffusion and provides an indication of the relative importance of each. The Péclet was calculated as 1.48 indicating that dispersion strongly impacted mass transport. Plug flow (no dispersion) would have a very high Péclet number, whereas systems with a Péclet number of 5 or less are considered to have a large amount of dispersion (Levenspiel 1962). System bypass was identified in several modules at the O-ring connection between the module and the water distribution header. Bypass may have further contributed to dispersion observed in the MBfR. The O-ring was replaced with a screw connection on day 146, which eliminated the bypass problem.

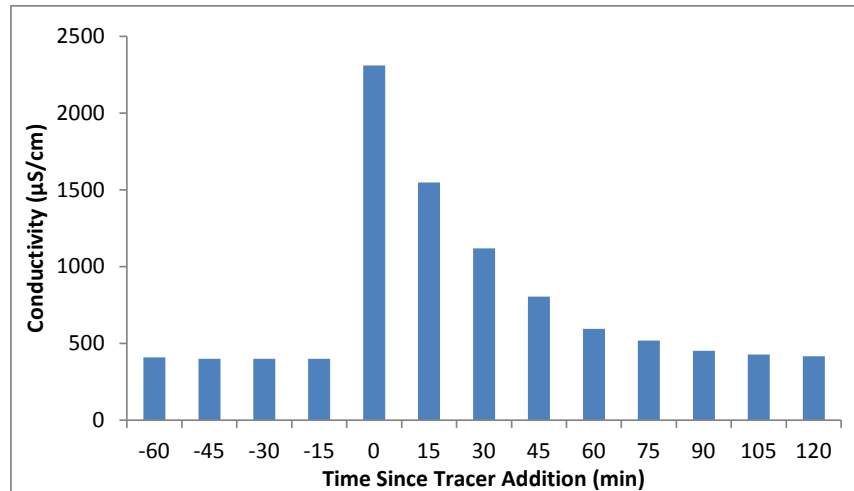

Figure 5.12 MBfR Lag Tracer Study

5.7.2 Optimization

System optimization lasted from day 113 to 230. The purpose of this phase was to identify optimal operating conditions to enhance performance of the MBfR. A range of conditions were systematically evaluated including altering influent flow rates and thus electron acceptor loading, MBfR vessel recycle flow rates to alter mass transfer rates, hydrogen pressure to alter electron donor delivery capacity, sparge frequencies, and sparge gases (i.e., use of nitrogen gas compared to compressed air). This provided a comprehensive dataset to evaluate relationships between controlling parameters and performance. Several system upsets occurred between days 113 and 127, and a few modules failed due to delamination of the epoxy head from the reactor core (Table 5.7). These failures were attributable to the manufacturing process that has since been rectified. The recycle flow rate in each reactor was subsequently reduced proportionally to the reduction in the number of membrane modules to maintain a constant water velocity in each module. The first two module failures occurred on day 150; these modules were removed and the membranes were inspected. Figure 5.13 shows the surface of the membrane sheets, which line the reactor interior. Samples of the membrane were sent to ASU for analysis and are referred in their report as shipment number 3 (Rittmann et al. 2013). Biomass was evenly distributed and was not overly reduced (overly reduced biomass appears dark brown or black in color). These observations contrast to the previous Demonstration conducted at EVWD where dark patches of overly reduced biomass were observed. This difference indicates the module design changes between the EVWD and WWWD Demonstrations were successful with respect to improving control of biofilm growth.

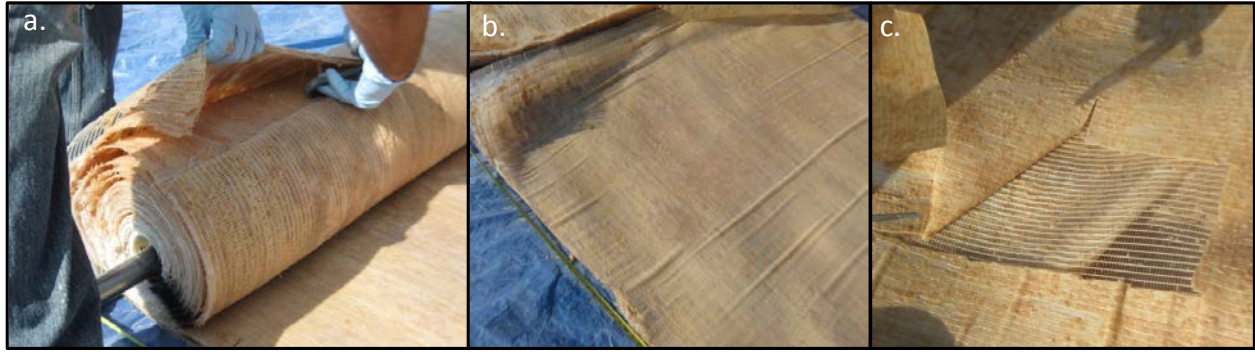
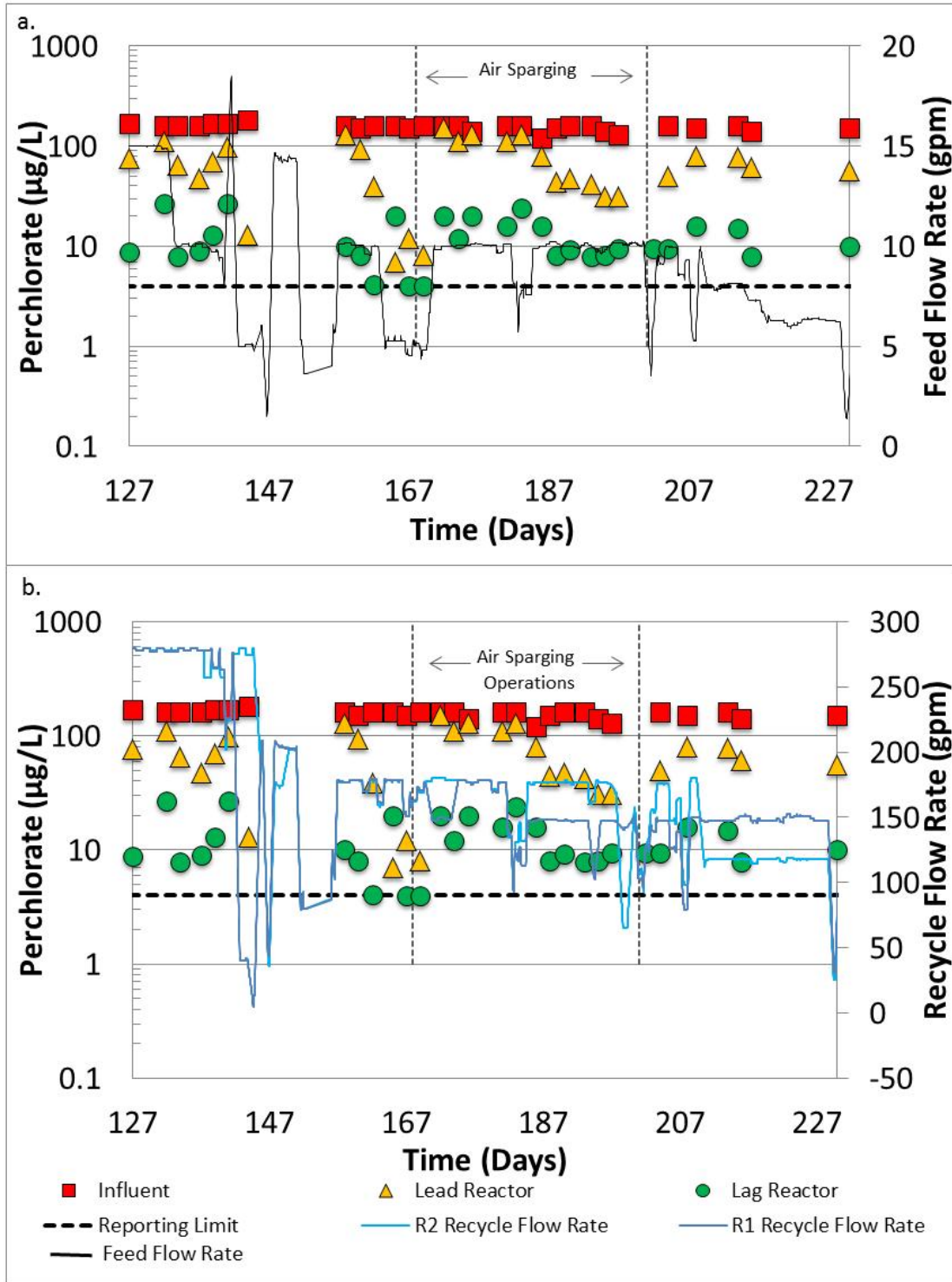

Figure 5.13 Autopsy of MBfR Reactor Modules

Figures 5.14 and 5.15 show an overview of perchlorate and total nitrogen concentrations in the system influent, effluent of the lead reactor, and effluent of the lag reactor under a range of influent flow rates, recycle flow rates, and hydrogen pressures. Influent flow rates were varied between 5 and 20 gpm, recycle flow rates varied between 100 and 280 gpm, and the hydrogen pressure ranged from 11 to 28 psi. Optimization included a series of short-duration tests to systematically evaluate impacts of a single operational change. However, several upset conditions occurred during this time frame (see Table 5.7), and in an effort to find optimal conditions, several parameters were altered simultaneously. The short-duration tests are discussed in detail below to demonstrate the impact of two-stage (e.g. lead/lag) compared to single-stage operations and varying influent flow rate, recycle flow rate, hydrogen pressure, sparge frequency, and use of nitrogen gas compared to compressed air for sparging.

On days 143 and 144 the system was operated with only one vessel to determine whether single-stage treatment would suffice. Prior to this time, the two-stage system was operated at 10 gpm. On day 143 MBfR2, which had previously been in the lead position, was operated at 5 gpm and MBfR1 was taken off-line. The recycle flow rate in MBfR2 was 280 gpm and the hydrogen pressure was 13 psi. Influent perchlorate was 180 $\mu\text{g/L}$ and total nitrogen was 9.7 mg-N/L; the MBfR effluent perchlorate was 13 $\mu\text{g/L}$ and total nitrogen was 0.59 mg-N/L. While these values do not meet the performance objective for nitrate or perchlorate, a large percentage (93 percent for perchlorate and 94 percent for nitrate) was removed. Table 5.11 shows two-stage data under similar operating conditions for comparison on day 139. The influent perchlorate was 170 $\mu\text{g/L}$ and lag effluent was 13 $\mu\text{g/L}$. Online nitrate readings were 8 mg-N/L at the influent and 0.54 mg-N/L in the lag reactor. While the perchlorate and nitrate loading during single-stage operations on day 143 were slightly higher than two-stage on day 139, the system was operating under similar conditions. The performance in removal of perchlorate and nitrate (measured in terms of removal normalized to membrane area) was similar regardless of whether the system operated as single- or dual -stage indicating little benefit of two-stage operation.



Note: Flow rates are 24-hour moving averages. R1 and R2 switched between lead and lag positions during optimization.

Figure 5.14 Optimization Perchlorate and Influent Flow (a) and Recycle Flow (b)

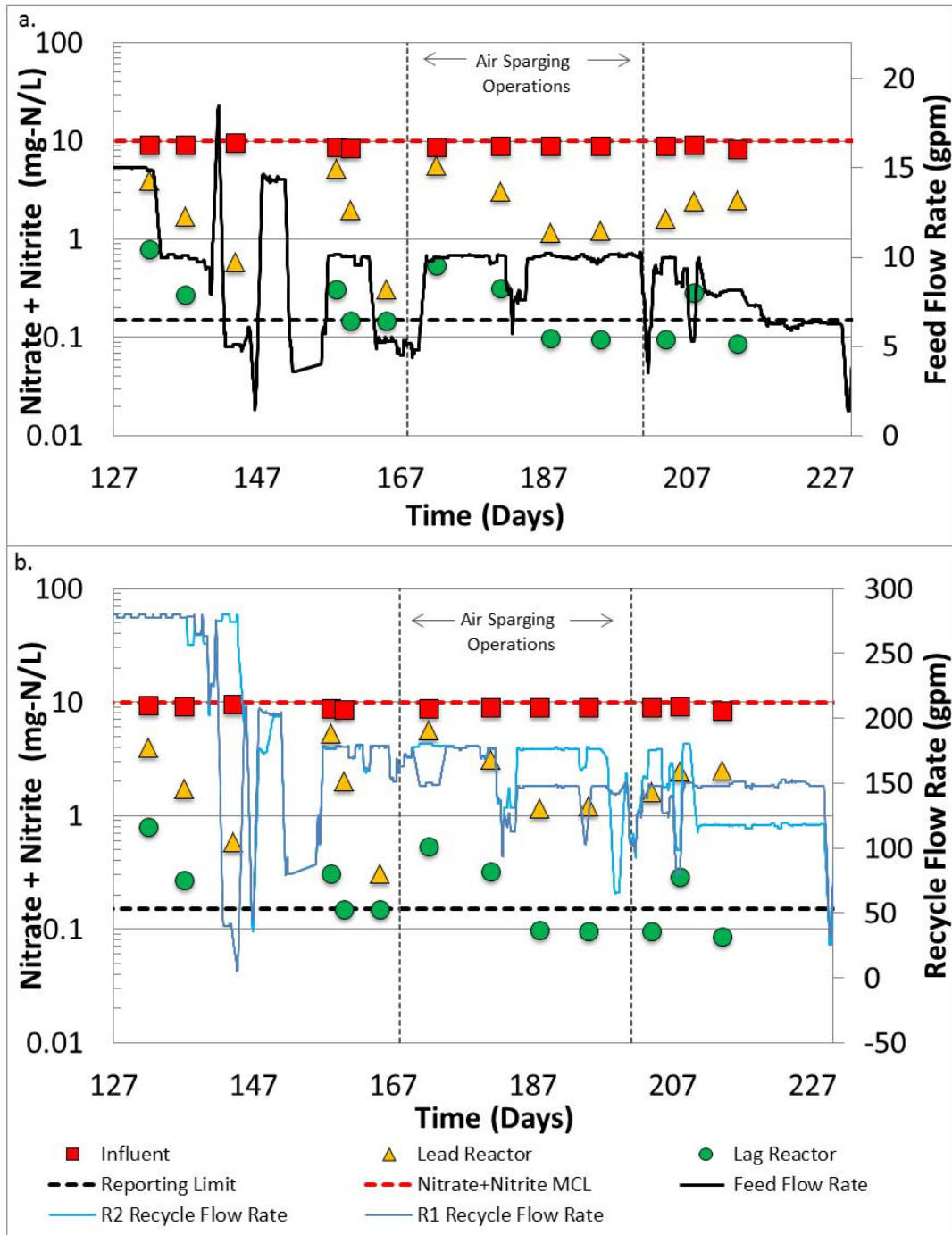

Note: Flow rates are 24-hour moving averages. R1 and R2 switched between lead and lag positions during optimization.

Figure 5.15 Optimization Total Nitrogen and Influent Flow (a) and Recycle Flow (b)

Single-stage and dual-stage operation did not promote complete perchlorate reduction. The nitrate-plus-oxygen flux reported in terms of stoichiometric hydrogen demand during single-stage operation was $0.12 \text{ g-H}_2/\text{m}^2\text{-d}$. Laboratory and modeling studies conducted by ASU (see Section 5.3) indicated that complete perchlorate reduction without sulfate reduction should be

expected at a nitrate-plus-oxygen flux of $0.18 \text{ g-H}_2/\text{m}^2\text{-d}$ which is similar to the value reported above. Therefore, other differences between the laboratory and pilot-scale systems may have affected complete perchlorate reduction. These differences are discussed below and include external mass transfer resistance and excess hydrogen delivery.

Table 5.11 Comparison of Two-Stage and Single-Stage Operation

Parameter	Two-Stage (Day 139)	Single Stage (Days 143,144)
Influent flow rate (gpm)	10	5
Recycle Flow Rate (gpm)	280	280
Hydrogen Pressure (psi)	MBfR1 – 13 (lead) MBfR2 - 15	13
Membrane Surface area (m^2)	2,000	1,000
Perchlorate Loading ($\text{mg}/\text{m}^2\text{-d}$)	4.63	4.91
Nitrate Loading ($\text{mg-N}/\text{m}^2\text{-d}$)	218	264
Perchlorate Removal Flux ($\text{mg}/\text{m}^2\text{-d}$)	4.28	4.55
Nitrate+Nitrite Removal Flux ($\text{mg-N}/\text{m}^2\text{-d}$)	203	248

The effect of influent flow rate was evaluated for flows of 10, 15, and 20 gpm on days 127 to 141. Effluent perchlorate was, on average, $8.5 \mu\text{g/L}$ while operating at 10 gpm, $17.9 \mu\text{g/L}$ at 15 gpm, and $27 \mu\text{g/L}$ at 20 gpm. Recycle flow rates were at a maximum of 280 gpm in both vessels, and the hydrogen pressure was altered to keep the ratio of electron donor delivery to acceptor loading consistent. A batch test was conducted on day 141 (discussed below) and demonstrated that perchlorate reduction to less than the performance objective of $6 \mu\text{g/L}$ was possible although sulfate was reduced to sulfide. The combined results of the varying influent flow rate tests and the batch tests indicated that attainment of perchlorate performance objectives was possible if the system was given a long enough residence time. Flow rate was systematically tested again on days 208 to 230 with flows of 10, 8, and 6 gpm (Figure 5.16). Influent perchlorate was approximately $160 \mu\text{g/L}$ while the average lag effluent at 10 gpm was $11.7 \mu\text{g/L}$, 8 gpm was $11.4 \mu\text{g/L}$, and 6 gpm was $9 \mu\text{g/L}$. At these flow rates, total nitrogen (nitrate+nitrite) was consistently below 0.5 mg-N/L . Total nitrogen was attained below 0.5 mg-N/L when flows were as high as 15 gpm. However, optimization tests were focused on meeting both perchlorate and nitrate treatment objectives. The flow rate to be used for Steady State was determined to be 6 gpm based on these results.

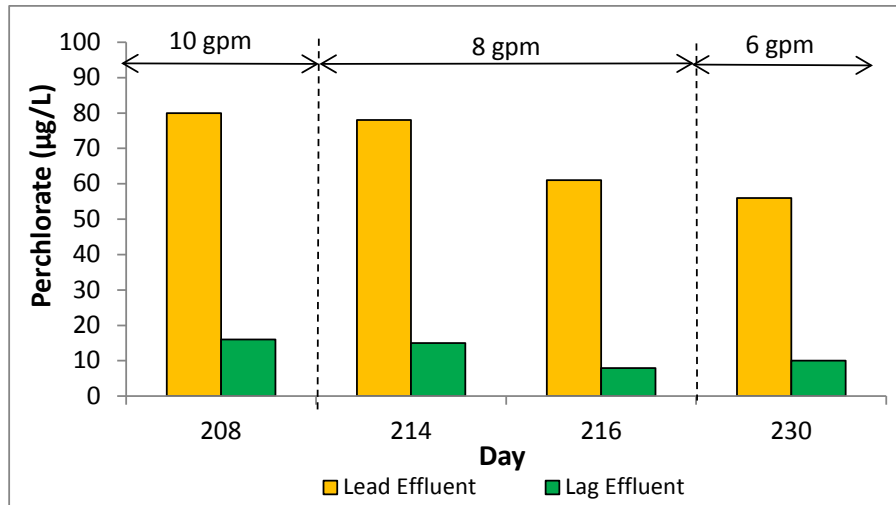

Figure 5.16 Effect of Influent Flow Rate on Perchlorate Removal

While operating conditions were varied during Optimization, perchlorate was not able to attain less than 6 µg/L in the lag effluent. Initial batch tests were conducted on day 141 to determine whether perchlorate concentrations could meet the performance objective of 6 µg/L or whether some inhibitory conditions (microbial or other) were present that were hindering performance (Figure 5.17, method details in Appendix D). Perchlorate was removed to less than 0.5 µg/L and total nitrogen (the sum of nitrate and nitrite) was removed to below detection in MBfR1 and MBfR2. Removal of perchlorate to concentrations below the performance objective began at the same time the sulfate reduction began, and nitrate was completely removed. These results agree with previous research which demonstrated a clear hydrogen utilization preference: oxygen, followed by nitrate, nitrite, and then perchlorate (Ziv-El and Rittmann 2009). The results also demonstrate that complete removal of perchlorate in the two-stage MBfR was possible.

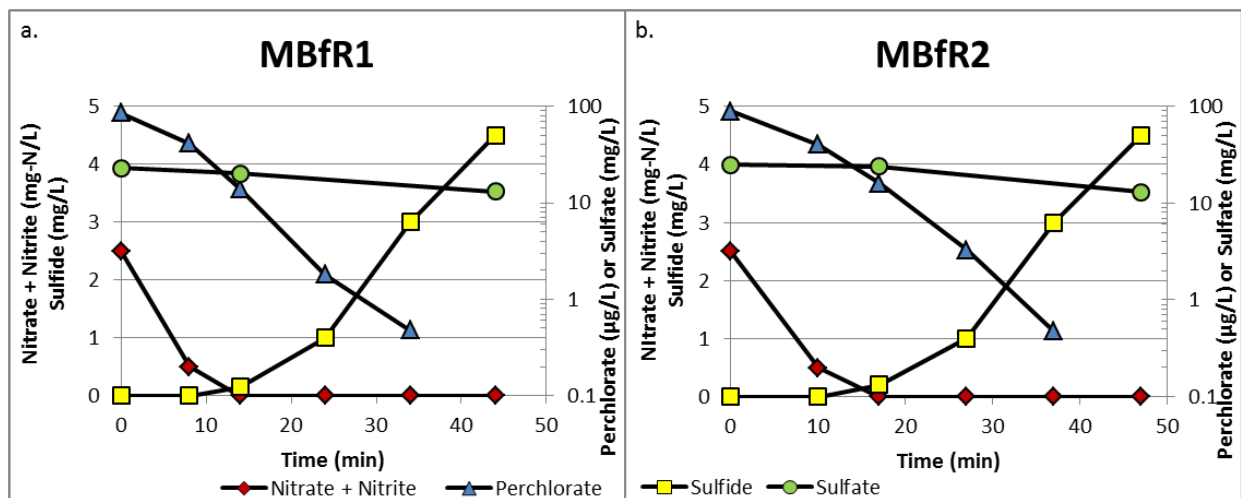
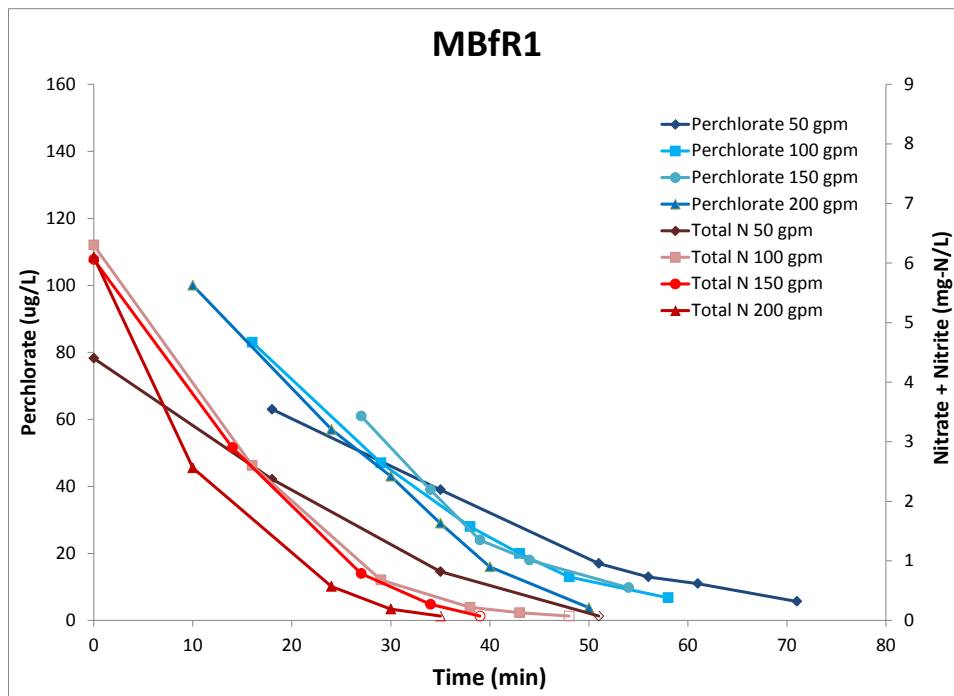

Figure 5.17 Preliminary Batch Test for MBfR1 (a) and MBfR2 (b)

Recycle flow rates were systematically evaluated by conducting a second series of batch tests on days 200 and 202 for MBfR 2 and 1, respectively. The tests showed that perchlorate and nitrate reduction occurred at a faster rate for higher recycle flow rates (Figures 5.18 and 5.19). The

recycle flow rates were slightly higher in MBfR2 than MBfR1 because MBfR2 had more membrane surface area with 6 modules rather than 4 modules in MBfR1. The flow rates were selected to provide similar conditions for mass transfer. While the highest recycle flow rate of 200 gpm in MBfR1 had the fastest rate of degradation, sulfide generation was also higher in this vessel, with as high as 2 mg/L after 50 minutes. Sulfate reduction also occurred in MBfR2, with 1.2, 2.4 and 2.3 mg/L sulfide at 180, 120 and 90 gpm, respectively after approximately 40 minutes (not shown). Similar to the preliminary batch test findings, sulfide generation began occurring after the nitrate concentration was below detection (<0.5 mg-N/L) and as perchlorate concentrations were below 20 µg/L. There appeared to be overlap between perchlorate- and sulfate-reduction.

First-order rate constants were calculated for perchlorate and nitrate reduction at various recycle flow rates (Table 5.12). While the first-order rate constants for nitrate reduction were similar between MBfR1 and MBfR2, the rate constant for perchlorate was more than double in MBfR2 at higher recycle flow rates. These data indicate the liquid-phase mass transfer resistance was controlling the rate of perchlorate reduction. The first-order rate constants for a recycle flow rate of 60 gpm in MBfR2 appeared to be an outlier, compared to the overall trend of increasing rate constants with increasing recycle flow rates. We hypothesize that the 90-gpm sample and 60-gpm sample were likely switched in the field.



Note: Open symbols show last data point included in first-order rate constant regression

Figure 5.18 MBfR1 Batch Test with Varying Recycle Ratios

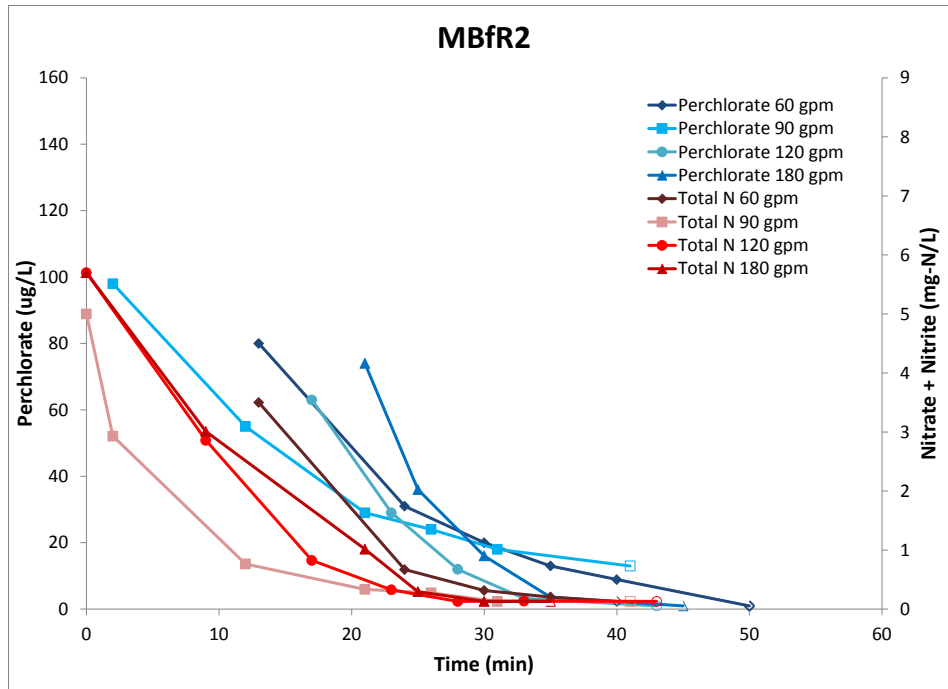

Note: Open symbols show last data point included in first-order rate constant regression

Figure 5.19 MBfR2 Batch Test with Varying Recycle Ratios

Table 5.12 Batch Test First-Order Rate Constants

MBfR1			MBfR2		
Recycle Flow (gpm)	Perchlorate (1/s)	Nitrate+Nitrite (1/s)	Recycle Flow (gpm)	Perchlorate (1/s)	Nitrate+Nitrite (1/s)
200	4.7	7.4	180	11	7.1
150	4.1	6.5	120	10	6.1
100	3.6	5.7	90	3.2	5.5
50	2.7	4.6	60	7.3	7.3

The final parameter varied during Optimization was sparge gas type and sparging frequency. Sparging with compressed air rather than nitrogen had no impact on performance for removal of nitrate or perchlorate (Figures 5.14 and 5.15). Effluent perchlorate concentrations were below $10 \mu\text{g/L}$ when sparging was conducted with nitrogen or with compressed air between days 190 and 205 (Figure 5.14). The frequency of sparging was varied from every 48 hours to every 4 hours. On days 156 to 162, flow rates and hydrogen pressures were constant while the sparge frequency was varied (Figure 5.20). The average lead and lag reactor effluent nitrate concentrations were 2.5 and 0.24 mg-N/L , respectively when sparging every 12 hours. This was similar to when the sparge frequency was every 24 hours, with 2.7 and 0.11 mg-N/L in the lead and lag vessel, respectively. On days 183 to 199, other conditions were held constant and the sparge frequency was varied. The average lead and lag reactor effluent nitrate concentrations were 1.6 and 0.44 mg-N/L , respectively when sparged at 12-hour intervals. Concentrations were similar at a sparge frequency of every 4 hours at 1.7 and 0.35 mg-N/L . In summary, the sparge frequency had little impact on effluent concentrations of nitrate in the range of every 4 hours to

every 24 hours. Therefore, the sparging frequency for Steady State was set at 12 hours to minimize system down time without compromising performance.

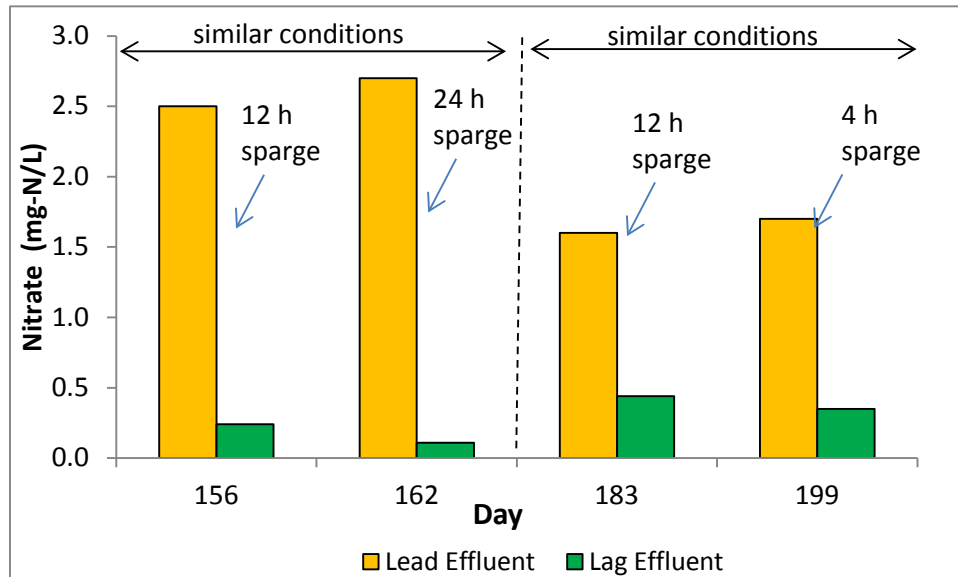

Figure 5.20 Effect of Sparge Frequency on Nitrate Performance

5.7.3 Steady State

The Steady State phase lasted from day 230 to 258. Operations were held constant using the optimal conditions identified during Optimization (Table 5.13). Flow rate was set at 6 gpm to increase the hydraulic residence time and promote greater perchlorate reduction. Phosphate was dosed to attain an influent concentration of 0.5 mg/L. Hydrogen was fed to the MBfR at a rate of 0.05 SCF/gallon of water treated and carbon dioxide at a rate of 0.002 SCF/gallon of water treated. Module sparging occurred every 24 hours using nitrogen. An aluminum chlorohydrate coagulant was added as a filter aid at a dose of 0.1 g/min prior to filtration. After media filtration, sodium hypochlorite was added as a disinfectant to achieve 0.2 mg/L residual chlorine at the effluent of the finished water tank.

The system was online approximately 98 percent of the time which met the performance objective of greater than 95 percent uptime. However, on days 250, 251, and 252 (January 3, 4, and 5, 2012) the system was temporarily shut down due to false triggering of high-level sensors in the secondary containment and in Reactor 2. The sensors were tripped each day by abnormally high winds (the Santa Ana winds). This was not included as down time because the trigger was not associated with normal operating conditions.

Table 5.13 Steady State Operating Parameters

Parameter	Value/Set Point
Influent Flow Rate	6 gpm
Influent Oxygen	8.7 mg/L
Influent Nitrate	8.6 mg-N/L
Influent Perchlorate	154 µg/L
Oxygen Loading	248 mg O ₂ /m ² -d

Parameter	Value/Set Point
Nitrate Loading	246 mg-N/m ² -d
Perchlorate Loading	4.41 mg ClO ₄ /m ² -d
Sparge Frequency	12 hours
Recycle Flow Rate	R1 - 150 gpm R2 - 120 gpm
Hydrogen Pressure	R1- 16.5 psi R2 - 16.5 psi

Perchlorate and nitrate removal during Steady State was consistent over time (Figure 5.21). Perchlorate was reduced from an average of 154±5 µg/L to an average of 9.2±2.3 µg/L in the effluent of the lag reactor during Steady State (94.4 percent reduction). While perchlorate was above the treatment objective of 6 µg/L, nitrate met the treatment objective of 0.5 mg/L in the effluent. Nitrate + nitrite were reduced from an influent average concentration of 9.0 mg-N/L to an average of 0.12±0.07 mg-N/L at the MBfR lag effluent (98.3 percent reduction).

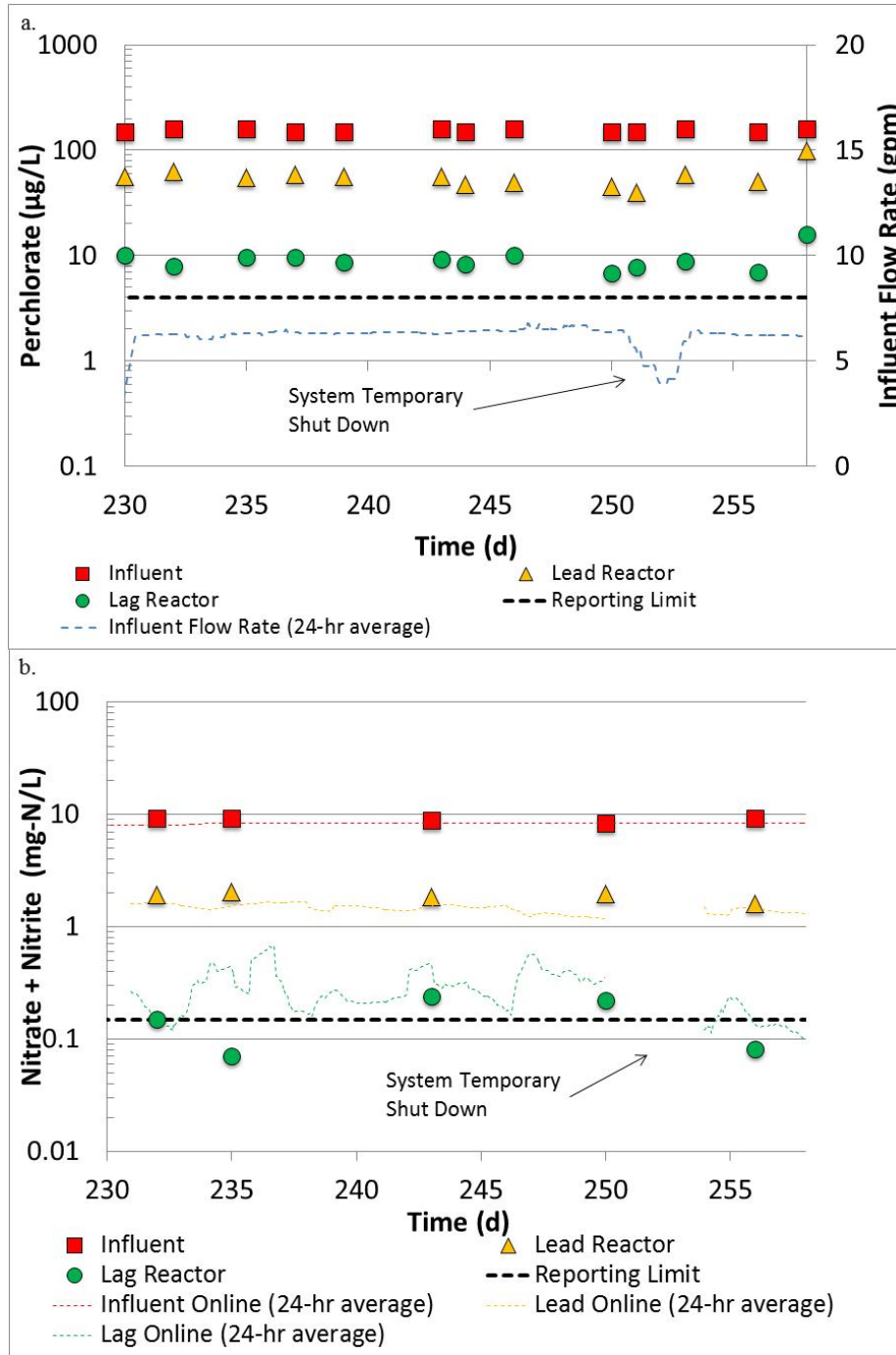

Figure 5.21 Steady State MBfR Perchlorate and Flow Rate (a) and Total Nitrate+Nitrite (b)

Hydrogen demand was calculated based on theoretical stoichiometric requirements for conversion of oxygen to water, nitrate to nitrogen gas, and perchlorate to chloride. Hydrogen was also consumed for sulfate reduction, but this was only five percent of the total stoichiometric demand and was not included in the calculation. The lag reactor effluent sulfide concentration was on average 1 mg/L, which is equivalent to 3 mg/L sulfate consumption. For an influent flow rate of 6 gpm, the hydrogen demand was 0.51 SCFH for oxygen, 1.89 SCFH for nitrate, and 0.02

SCFH for perchlorate. On average 29.6% of the hydrogen fed to the lead reactor was biologically consumed based on stoichiometric demand (determined by calculation), 24.9% was used during intentional membrane fiber flushing to eliminate water vapor condensation and accumulation of inert gases such as nitrogen (measured), and 45.4 percent was excess (calculated by subtracting stoichiometric demand and fiber flush flow from total flow) (Figure 5.22). In the lag reactor, 6.6 percent of the hydrogen was used for stoichiometric demand (primarily for removal of residual nitrate and perchlorate), 26.8 percent for membrane fiber flushing, and 66.5 percent was excess. The lead reactor had higher hydrogen use than the lag reactor because of greater influent concentrations of oxygen and nitrate. Since the lead and lag reactors switched positions between vessels periodically, the hydrogen demand associated with either MBfR1 or MBfR2 varied depending on position. The system operated with excess hydrogen in an attempt to achieve complete perchlorate reduction. This excess may have been one of the reasons that sulfate-reducing bacteria outcompeted perchlorate-reducing bacteria and prevented complete perchlorate reduction.

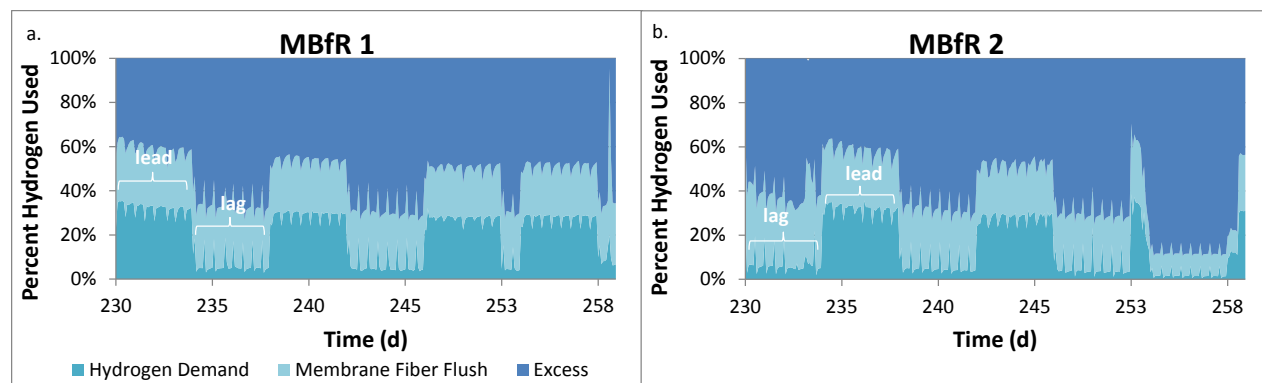

Figure 5.22 Steady State Stoichiometric Hydrogen Demand, Hydrogen for Membrane Fiber Flushing, and Excess Hydrogen

Carbon dioxide was used for pH control and as a carbon source for autotrophic cell synthesis. The influent pH was on average 7.52 ± 0.11 SU and additional alkalinity was generated from the reduction reactions, particularly denitrification. The set point for both reactors was 7.2 SU, and pH adjustment between 7.5 and 7.2 SU accounted for the largest portion of carbon dioxide demand (62 ± 0.1 percent). Approximately 30.5 ± 0.1 percent of the carbon dioxide demand was used for alkalinity generated during reduction of oxygen, perchlorate, nitrate, and sulfate following the stoichiometry discussed in Section 2.1 (Stumm and Morgan 1996). Only a small fraction of the total carbon dioxide needed was associated with cell synthesis, approximately 7.0 ± 0.2 percent. Approximately 9,000 L of carbon dioxide were used during the one-month Steady State period. Of this flow, approximately 5,300 L were used for pH adjustment, 1,900 L were for neutralizing alkalinity generated during reduction reactions (primarily driven by nitrification), 440 L were for cell synthesis, and the remaining 1,360 L (15 percent) were excess or system losses suggesting potential for optimization.

Bacteria were detected in the MBfR effluent, which was likely associated with detachment of biomass from the membranes (Figure 5.23). The lag reactor effluent had HPC counts between 10^4 and 10^5 colony forming units per milliliter (CFU/mL). *E. coli*, total coliforms, and fecal coliforms were below the detection limit of 2 most probable number per 100 milliliters

(MPN/100mL) in all samples collected. There were three time points when total coliforms were detected during Steady State, on days 232, 243, and 256. The highest detection was on day 232 with 36.7 MPN/100mL. These samples were collected prior to disinfection. While this system is a biological treatment technology, the growth of pathogenic organisms was not promoted.

HPCs were significantly lower in the finished water following disinfection, on average 43 CFU/mL (Figure 5.24). All samples collected from the finished water were below drinking water standards for *E. coli*, total coliforms, fecal coliforms, and HPCs. TON was below the Secondary MCL of 3 in all but three samples (Figure 5.24b). Those were on days 246, 250, and 251 with an average threshold odor number of 4.5. Day 250 also had the highest total sulfide measurement during Steady State of 0.041 mg/L. The system was down periodically on days 250 to 253 due to high winds triggering the secondary containment level switch. When the system was down, the MBfRs operated in batch mode, which resulted in more strongly reducing conditions than normal operations.

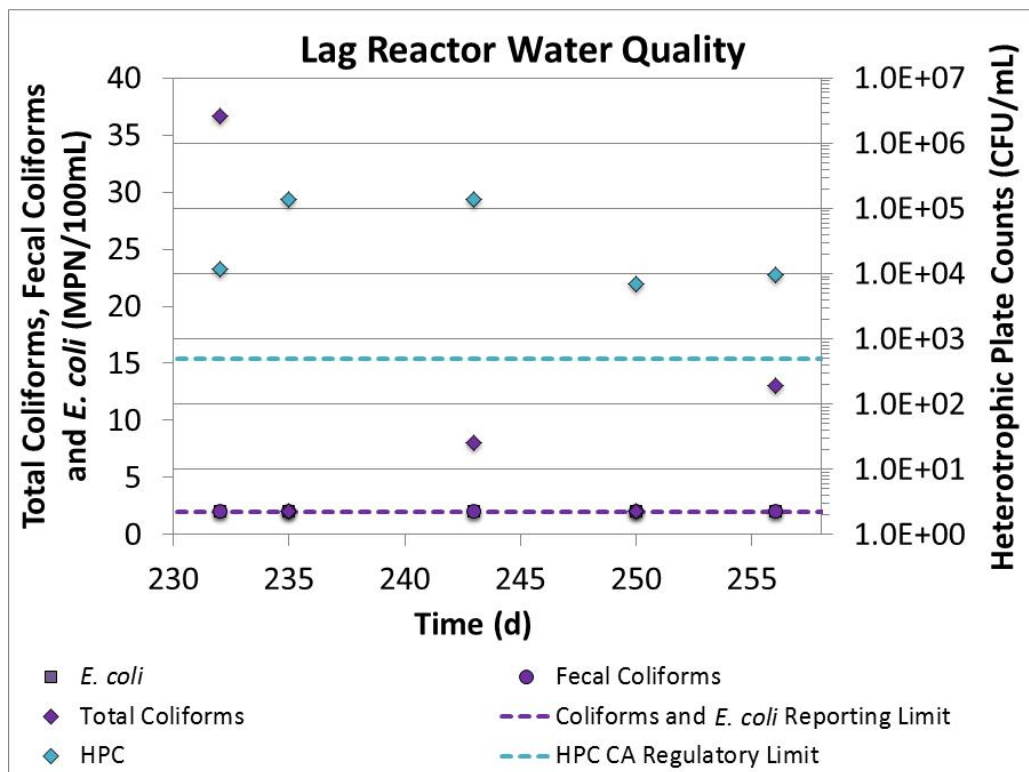

Figure 5.23 Steady State MBfR Lag Reactor Effluent Water Quality Bioindicators

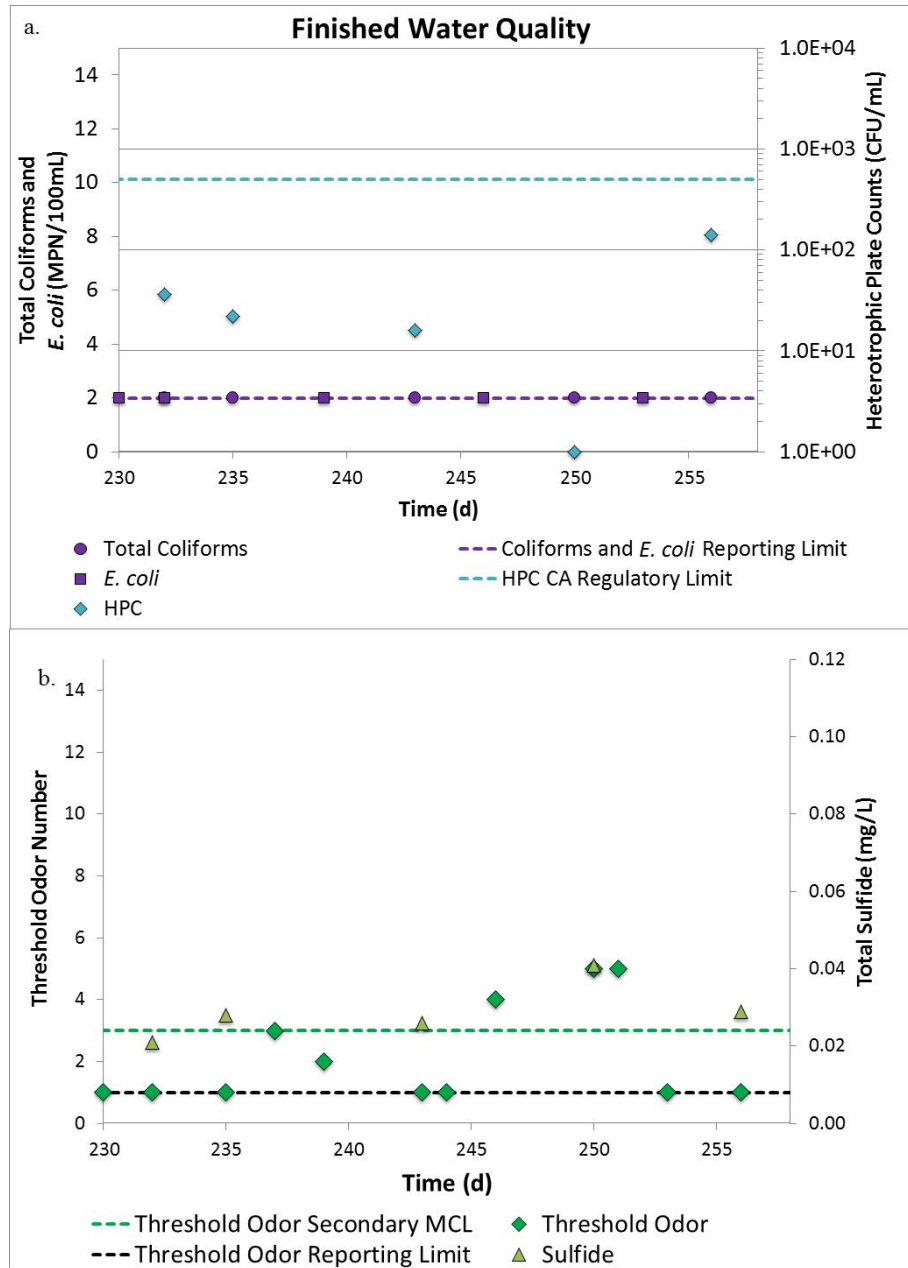

Figure 5.24 Steady State Finished Water Quality Bioindicators (a), Sulfide, and Odor (b)

The performance objective for DOC was to have less than a 0.2-mg/L increase from the system influent to the finished water (Figure 5.25). DOC increased in the effluent of the MBfR lag, but was subsequently reduced by the media filter. DOC increased an average of 0.4 ± 0.1 mg/L from the influent to the effluent during Steady State. Influent DOC concentrations were uncharacteristically high (above 1 mg/L) in three of the five time points tested. The average influent DOC was 0.56 ± 0.38 mg/L prior to Steady State. It is not known why concentrations increased. This higher than normal organic loading may have resulted in increased biomass production thus increasing the effluent DOC. While the goal for this project was less than a 0.2 mg/L increase, the metric is not driven by regulation, and requirements for biological stability

are specific to each drinking water distribution system. The increase of 0.4 mg/L DOC may not be all biodegradable DOC and may be stable in some distribution systems.

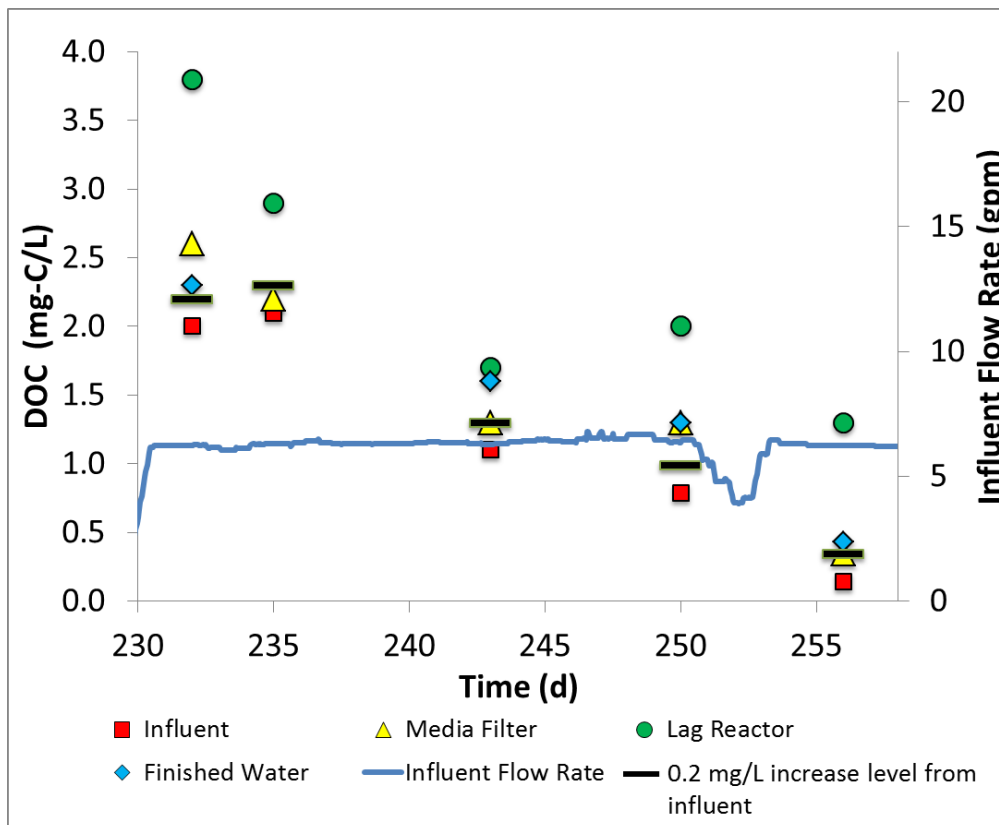

Figure 5.25 Steady State Treatment System DOC

DBPs including HAAs and THMs were measured in the finished water (Table 5.14). DBPs were below the MCL in all samples. DBP-FP was tested to determine DBPs generated during worst-case conditions; concentrations were significantly lower than the MCL (< 20 percent of the MCL). Nitrosamines including N-nitrosodiethylamine (NDEA), N-nitrosodimethylamine (NDMA), and N-nitroso-di-n-propylamine (NDPA) were below their respective CDPH Notification Level of 10 nanograms per liter (ng/L), or 0.01 µg/L, in the finished water. Nitrosamines are emerging contaminants that are not currently regulated for drinking water (e.g., no MCL) but are being evaluated by the USEPA.

Table 5.14 Steady State Finished Water Disinfection Byproducts

Analyte	Average	Max	MCL
HAA5 (µg/L)	<6	<6	60
HAA6 (µg/L)	<7	<7	--
TTHMs (µg/L)	4.8	12	80
Maximum THM-FP (µg/L)	14.6	47	--
Nitrosamines (µg/L)	<0.0019	<0.0019	--

Finished water turbidity was near the treatment objective of 0.2 NTU, with an average of 0.27 NTU (Figure 5.26). Turbidity was below 0.2 NTU 67 percent of the time based on on-line turbidity measurements. The intermittent temporary system shutdowns during days 250 to 253 were not included in turbidity analysis since it was triggered by weather events (i.e., high winds) and not normal operational issues. The SWTR requires that turbidity always be below 1 NTU and that 95 percent of the samples be less than 0.3 NTU. While this system utilized groundwater as a source water, the performance goal was to achieve turbidity of less than 0.2 NTU. The turbidity was not always below 1 NTU, although samples were below 0.3 NTU approximately 79 percent of the time and below 0.2 NTU approximately 67 percent of the time. The majority of time points where turbidity was above 0.2 NTU were from days 230 to 235. During this time, a noticeable sulfur odor was present in the aeration tank. Sulfate was being reduced to sulfide and possibly elemental sulfur due to strongly reducing conditions in the MBfR. Colloidal sulfur may have contributed to higher turbidity readings. The filter aid dose was adjusted from 2 to as high as 7 mL/min to reduce filter effluent turbidity. The filter aid was an aluminum chlorohydrate coagulant and was injected prior to the media filter. As such, the residence time may not have been sufficient to promote mixing and coagulation. Figure 5.26 shows turbidity breakthrough almost immediately after a backwash. The filtration system has a non-standard filter material and was not optimized for filtration performance. An improvement on the system design would be to inject the filter aid further upstream.

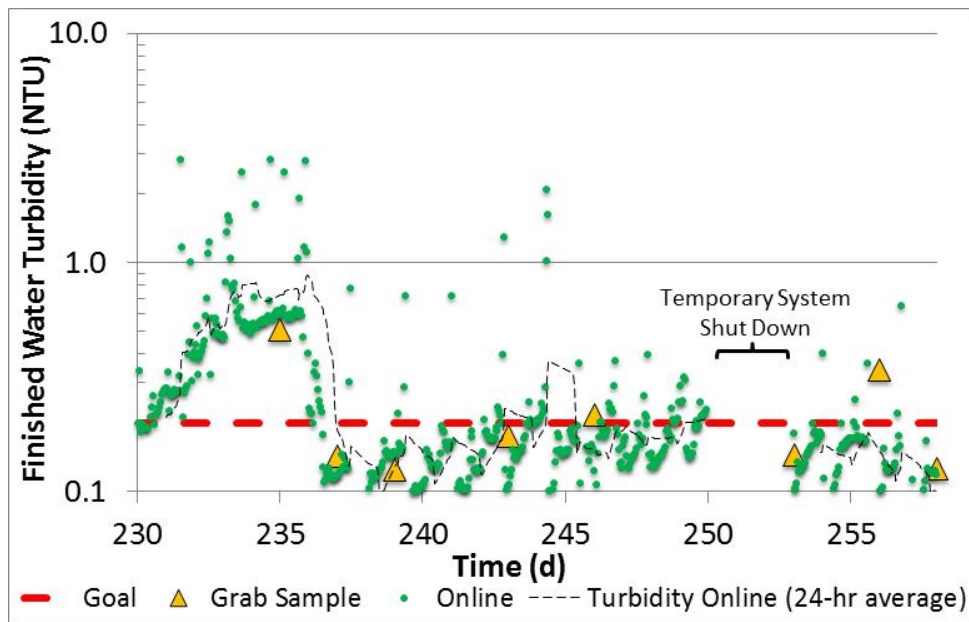

Figure 5.26 Steady State Finished Water Turbidity

The MBfR reactors were sparged every 12 hours. Approximately 13 percent of the influent water was used for sparging and was diverted as wastewater. A full-scale system currently installed at Cucamonga Valley Water District for nitrate reduction wastes approximately 1 to 3 percent of the influent water due to sparging.¹ Samples from the sparge water were collected and analyzed

¹ Based on information provided by APTwater, 2 to 3 percent of influent flow would likely be wasted in a full-scale system. There are several parameters that would be altered to achieve lower percent water wasted. First, if the influent flow rate increased, the percent wasted would be reduced appreciably because the reactors were sparged on

for total suspended solids (TSS) to estimate mass of solids generated. Based on these samples, approximately 2,930 grams or 6.5 pounds of solids would have been generated per million gallons (MG) of water treated. Theoretical sludge production using cell yields and stoichiometric equivalents presented in Section 2 would have been 4,000 g/MG water treated (8.9 pounds).

The media filter was backwashed on average approximately every 12 hours, which resulted in wasting approximately 3 percent of the system influent water due to backwashing. The backwash trigger was changed during Steady State to when finished water turbidity was greater than 0.3 NTU rather than when the pressure drop was greater than 10 psi. The trigger was altered because turbidities were higher than the performance objective of 0.2 NTU at the initiation of the Steady State phase. Samples from the media filter backwash water were collected and analyzed for TSS to estimate solids generated for disposal. Based on these samples, approximately 10,000 grams or 22 pounds of solids were generated per MG of water treated. The head loss accumulation rate across the media filter was fairly consistent at 5.2 ± 1.5 psi/d (Figure 5.27).

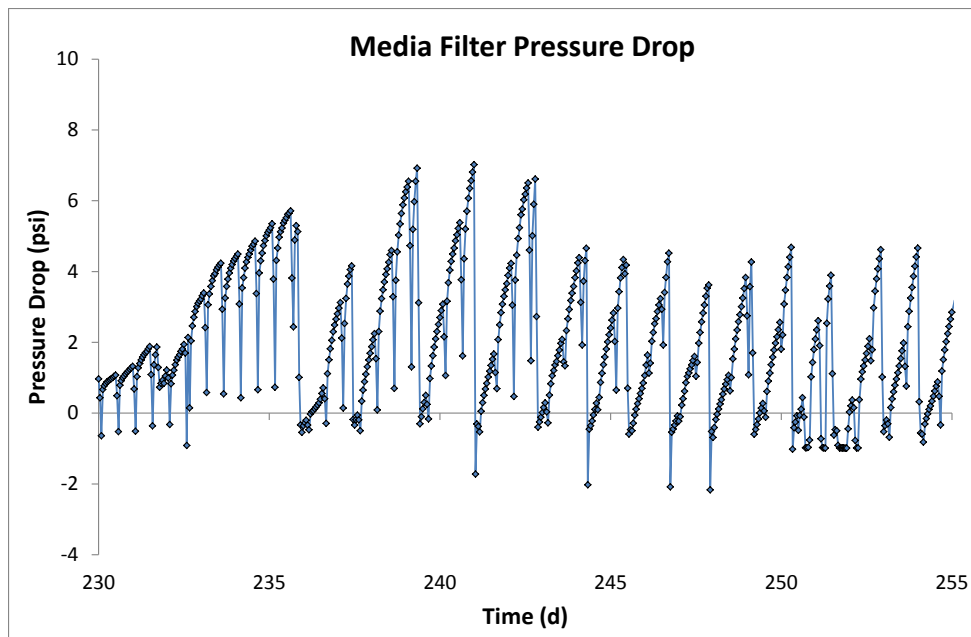

Figure 5.27 Steady State Media Filter Pressure Drop

5.7.4 Challenge

The Challenge phase lasted from days 259 to 271. There were four intentional upset conditions evaluated: turning off the hydrogen supply for 4 and 24 hours, and turning the system off completely for 4 and 24 hours. After the system was restored to normal operating conditions, the

a specified time interval. Increasing the flow rate from 6 to 20 gpm would result in a reduction of water wasted from 13 to 4 percent. Second, the initial transfer of water from the lag reactor during the sparge process to reduce the lag MBfR operating level was discharged as waste in the pilot. This fluid would not need to be wasted in a full-scale system because the water has been treated and is of the lag MBfR water quality. This would reduce wastewater by approximately half. Finally, during Steady State there were 4 reactors in each vessel rather than 7 at the initiation of the pilot. Since there were fewer reactors in the vessels, there was more space for water to fill the vessels, thus increasing water consumption. A full-scale system has been installed and tested at Cucamonga Valley Water District for nitrate reduction. This system wastes approximately 1 to 3 percent of the influent water due to sparging.

finished water was monitored approximately hourly for 10 hours. The influent flow rate was 6 gpm and the hydraulic residence time from the MBfR lag effluent to the finished water was approximately 2.4 hours. The baseline lag effluent concentrations prior to the intentional upsets were 16 $\mu\text{g/L}$ for perchlorate and 0.23 mg-N/L for nitrate.

The hydrogen shut-off simulated a temporary loss of electron donor supply. Approximately two hours after restarting the system, the concentrations of perchlorate and nitrate steadily dropped during the 4-hour hydrogen shut-off period (Figure 5.28) and 24-hour shut-off period (Figure 5.29). This corresponded well with the hydraulic residence time between the lag reactor and the finished water monitoring point. The rate of recovery was slightly faster for perchlorate after the 4-hour shut-off period (first-order rate constant of 0.173 hr^{-1}) than the 24-hour period (0.147 hr^{-1}). By contrast, nitrate was slightly slower to recover after the 4-hour shut-off period (0.152 hr^{-1}), compared to the 24-hour period (0.195 hr^{-1}). In both situations, nitrate recovered to less than 1 mg-N/L within the 10-hour period of monitoring. While perchlorate did not reach pre-upset concentrations within the monitoring period, the concentration would likely recover within 12 hours based on these first-order rate constants. One contribution to this recovery time was the presence of only 4 modules in each vessel designed for 7 modules. Thus, a substantial percentage of the liquid volume in each vessel was not in contact with the active biomass and thus was not subject to biodegradation up re-instatement of hydrogen flow. The recovery trends were similar to the tracer study trends indicative of high reactor dispersion and CSTR-type operation.

Turning off the power supply did not have strong impacts on effluent water quality after the 4-hour shut-off (Figure 5.30) or the 24-hour shut-off period (Figure 5.31), as concentrations remained relatively constant. For these cases, the reactors went into a batch reactor mode, which resulted in more contact time with the contaminated water. While sulfide was not monitored in any of the Challenge phase tests, this would be helpful to be included in a monitoring program for a full-scale system for potential odor issues.

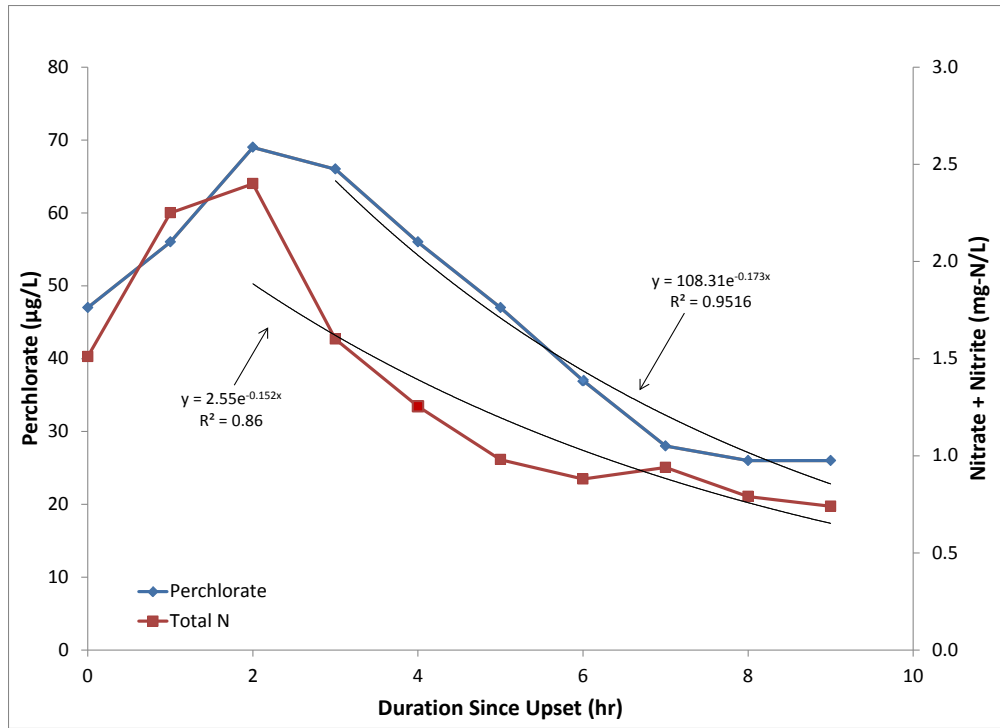

Figure 5.28 Perchlorate and Total Nitrogen Concentrations at the Finished Water after a 4-Hour Shut-off of Hydrogen

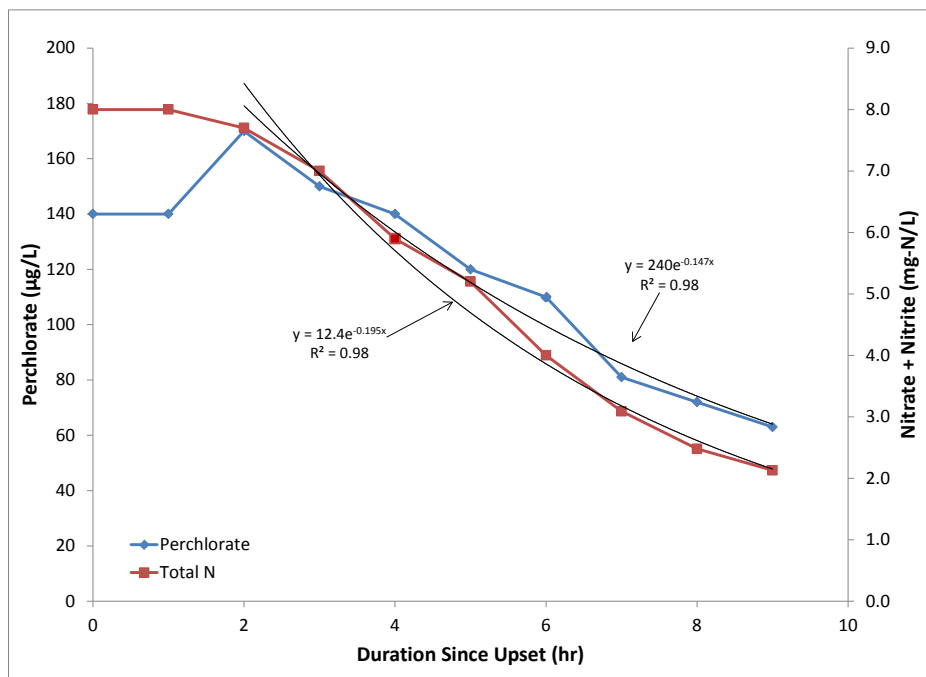

Figure 5.29 Perchlorate and Total Nitrogen Concentrations at the Finished Water after a 24-Hour Shut-off of Hydrogen

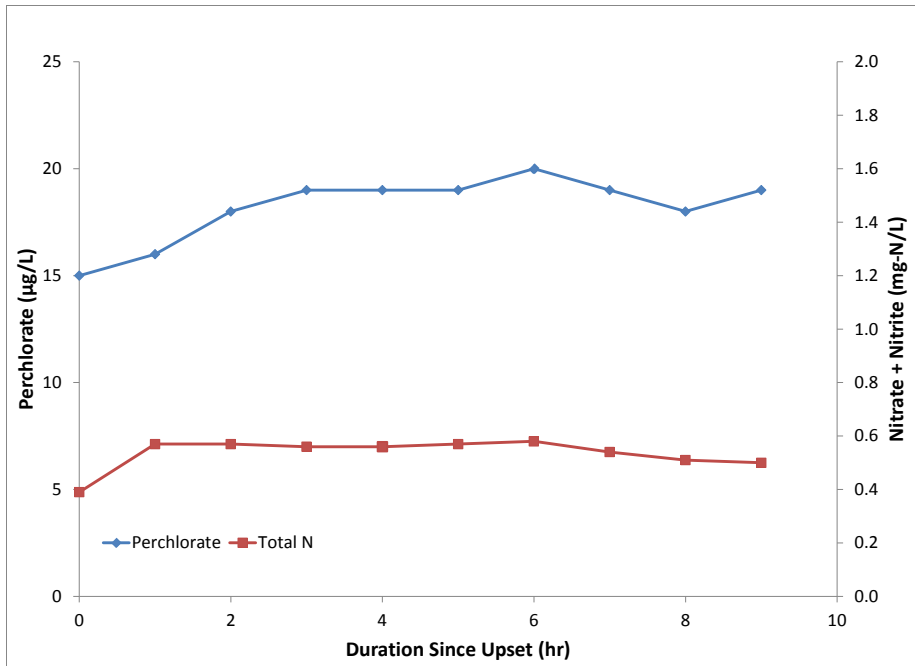

Figure 5.30 Perchlorate and Total Nitrogen Concentrations at the Finished Water after a 4-Hour Shut-off of Power

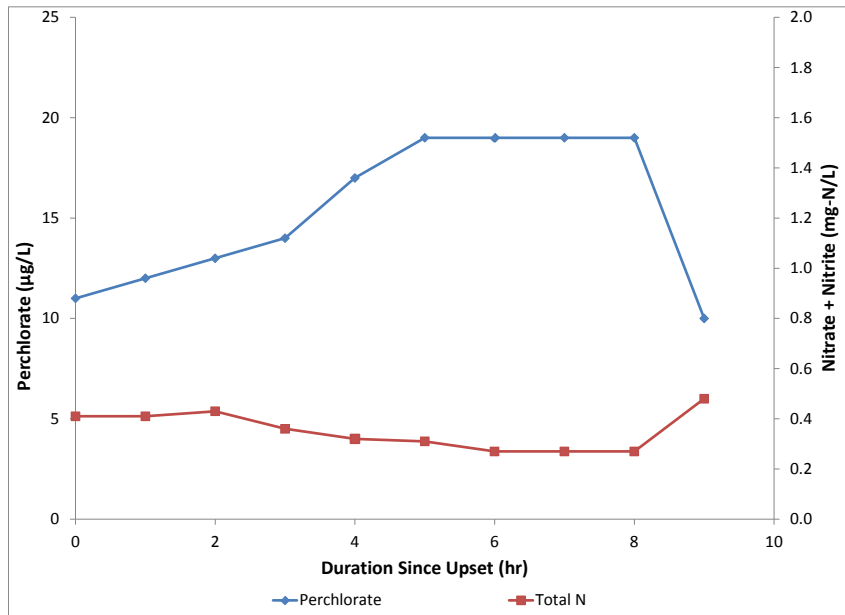

Figure 5.31 Perchlorate and Total Nitrogen Concentrations at the Finished Water after a 24-Hour Shut-off of Power

6.0 PERFORMANCE ASSESSMENT

A summary of the performance objectives along with an overview of technology performance was presented in Section 3, and results were discussed in detail in Section 5.7. The performance objectives included treatment effectiveness, disinfection effectiveness, ability to meet drinking water treatment primary and secondary MCLs, reliability, safety, permit compliance, and regulatory acceptance. This section includes an assessment of technology performance that is supported by data presented in Section 5.

6.1 TREATMENT EFFECTIVENESS

The MBfR was a reliable method for treating nitrate, and while perchlorate was not treated to below 6 $\mu\text{g/L}$, it was consistently reduced by more than 90 percent. Biomass was visually observable on the membrane surfaces during an autopsy of a reactor. Visually, the biomass was uniformly light brown in color, indicating the biomass was not overly reduced. Reliability of the system is discussed further in Section 6.4.

6.1.1 Perchlorate

Perchlorate was reduced from an average of $154 \pm 5 \mu\text{g/L}$ to an average of $9.2 \pm 2.3 \mu\text{g/L}$ in the effluent of the lag reactor during Steady State (94.4 percent reduction). While the treatment objective of 6 $\mu\text{g/L}$ was not met, perchlorate was consistently removed with little variation (coefficient of variation was 0.73%).

During Optimization, influent flow rate and recycle flow rate were observed to affect perchlorate treatment efficacy, as discussed in detail in Section 5.7.2. The effect of influent flow rate and associated electron acceptor loading was evaluated for flows rates of 10, 15, and 20 gpm. Perchlorate was on average 8.5 $\mu\text{g/L}$ while operating at 10 gpm, 17.9 $\mu\text{g/L}$ at 15 gpm, and 27 $\mu\text{g/L}$ at 20 gpm. Recycle flow rates were tested further during batch tests, where four recycle flow rates were tested in each MBfR vessel. In general, the best performance was observed when recycle flow rates were increased indicating mass transfer limitations. However, operation at the highest recycle rates did not promote complete perchlorate removal. Finally, the impact of sparge frequency and gas type was evaluated. Sparging was conducted to remove buildup of biomass and inert compounds in the membranes. Use of compressed air rather than nitrogen for sparging resulted in no measurable change in performance and could be used to decrease operational costs. Sparging frequencies of 24 hours or less did not change perchlorate or nitrate removal appreciably; thus 12 hours was selected for Steady State operations.

Batch tests demonstrated that complete perchlorate removal was possible but was observed to occur when sulfate reduction and sulfide generation began. Modeling and bench-scale studies by ASU demonstrated that complete perchlorate removal was observed without sulfide production if removal flux of nitrate and oxygen – expressed as stoichiometric hydrogen demand – was about 0.18 $\text{g H}_2/\text{m}^2\text{-day}$ (Rittmann et al. 2013). However, single-stage pilot-scale operation did not promote complete perchlorate reduction at a removal flux of nitrate and oxygen of 0.12 $\text{g-H}_2/\text{m}^2\text{-d}$. Therefore, other differences between the laboratory and pilot-scale systems such as trans-

membrane liquid velocity and associated mass-transfer resistance may have prevented complete perchlorate reduction.

6.1.2 Nitrate and Nitrite

This Demonstration validated the technical feasibility of the MBfR for treatment of nitrate. Total nitrogen (the sum of nitrate and nitrite) was reduced from an influent average of 9.0 mg-N/L to an average of 0.12 ± 0.07 mg-N/L in the effluent of the lag reactor during Steady State (98.3 percent reduction). Thus, the treatment objective of 0.5 mg-N/L was met. Nitrate reduction was consistently removed with little variation (coefficient of variation was 0.94%) with the highest total nitrate concentration of 0.24 mg-N/L. Similar to perchlorate, factors controlling performance were influent flow rate and recycle flow rate. These factors were evaluated in detail during Optimization (see Section 5.7.2). Nitrate removal to below 0.5 mg-N/L was demonstrated during Optimization testing at flow rates as high as 18 gpm based on online nitrate measurements. Recycle flow rates were tested at four different levels, and the best performance was generally observed when recycle flow rates were highest. Another key finding during Steady State was that 79 percent of nitrate was reduced across the lead reactor with an average lead effluent concentration of 1.8 ± 0.16 mg-N/L. As such, a full-scale system could include single-stage operations depending on nitrate treatment goals, thus decreasing capital and operational costs and system footprint.

6.2 DISINFECTION EFFECTIVENESS

Disinfection was accomplished using sodium hypochlorite with a free chlorine residual of 0.2 mg/L to meet disinfection requirements. Fecal coliforms, total coliforms, *E. coli*, and HPCs were used as indicator parameters for disinfection performance. Fecal and total coliforms and *E. coli* were below the detection limit (2/100 mL) in all samples during Steady State. HPCs were on average 43 MPN/mL, and no sample was greater than 500 MPN/mL during Steady State. Thus, the performance objective for disinfection effectiveness was met.

6.3 ABILITY TO MEET DRINKING WATER TREATMENT PRIMARY AND SECONDARY MCLs

This section addresses the ability of the MBfR to address primary and secondary MCLs and other constituents relevant to production of drinking water. TCE was present in the MBfR influent but was not removed. TCE removal was not an objective of this demonstration.

6.3.1 Odor

Biological reduction processes can include generation of sulfide. During batch testing discussed in Section 5.7.2, degradation of perchlorate below the performance objective of 6 $\mu\text{g/L}$ was observed during the same time when sulfide concentrations began increasing above approximately 1 mg/L. The performance objective for the TON was less than or equal to 3 based on the USEPA NSDWR requirements. An average TON of 2.2 was observed during Steady State; however, 3 of the 12 samples collected were above the performance objective. The three samples were associated with weather-related process shutdowns and accumulation of sulfide at

a concentration of 0.04 mg/L. This concentration of sulfide can be mitigated by a more rigorous aeration step. It is possible that the odor could have been associated with chlorine as well.

6.3.2 Turbidity

Media filtration in combination with a coagulant filter aid was employed downstream of the MBfR to meet the performance objective of less than or equal to 0.2 NTU in the finished water. An average turbidity of 0.27 NTU was observed from online measurements during Steady State. However, there were several instances where turbidity was greater than 1 NTU. Turbidity was below 0.2 NTU approximately 67 percent of the time, and thus this performance objective was not met. Most of the data when turbidity was above 0.2 NTU were from days 230 to 235. During this time, a noticeable sulfur odor was present in the aeration tank. Colloidal sulfur likely generated by oxidation of biogenic sulfide may have contributed to higher turbidity readings. Prevention of sulfide production would minimize turbidity exceedances. An improvement to the design to increase the filter aid efficacy would be to move the filter aid injection location further upstream to increase mixing time. Additionally, the experimental filter media Next-SandTM was used, thus turbidity results may not be translatable to conventional filtration media.

The media filter was backwashed on average approximately every 12 hours, which resulted in wasting 3 percent of the system influent water. Media filter backwash water was analyzed for TSS to estimate solids generated for disposal. Based on these samples, approximately 10,000 grams or 22 pounds of solids would have been generated per MG of water treated.

6.3.3 DOC

Residual biodegradable organic compounds in treated water can decrease water biostability and thus promote regrowth of organisms in distribution systems. DOC was selected as a surrogate indicator for biological stability, with a performance objective of no more than a 0.2-mg/L increase in DOC from the influent to the finished water. While this was a goal for the project, it was not driven by regulation and specific requirements for stability are specific to each drinking water distribution system. The increase in DOC from the system influent to the finished water was on average 0.4 mg/L during Steady State. The net increase in system DOC exceeded the performance objective indicating that the performance objective was not met. Even though this goal was not met, this increase may be suitable and considered stable in some distribution systems. Water stability in the distribution system is affected by many factors and DOC is just one of those factors (Schneider et al. 2013).

6.3.4 pH

The target for pH was between 6.5 and 8.5 SU, which is a secondary MCL under the NSDWR. In particular, pH control was important for this system since denitrification and other reduction processes can result in increased alkalinity and increased pH. Bioreduction pathways are optimal between a pH of 6.8 and 7.5 SU for perchlorate (Adham et al. 2004), though optimal perchlorate was found at 8 SU when a range between 6.5 to 8.8 was tested (Nerenberg et al. 2002) and 7.2 to 8.2 SU for nitrate (Xia et al. 2010). During the MBfR Demonstration, the pH of the finished water remained within the performance standards ($6.5 \leq \text{pH} \leq 8.5$). An average value of

7.8±0.2 SU was observed at the finished water during Steady State. The metric for this performance objective was met.

6.4 RELIABILITY

This performance objective was to demonstrate greater than 95 percent uptime during Steady State. The system uptime during Steady State was 98 percent and this performance objective was met. System reliability was further evaluated during Challenge testing when either hydrogen (electron donor) or system power was shut off for either 4 hours or 24 hours. As discussed in Section 5.7.4, hydrogen shut-off resulted in increased nitrate and perchlorate concentrations. System recovery occurred within 10 hours for nitrate, and was anticipated to occur within 12 hours for perchlorate. First-order rate constants were calculated to estimate recovery time. The rate of recovery was slightly faster for perchlorate after the 4-hour shut-off period (first-order rate constant of 0.17 hr⁻¹) than the 24-hour period (0.15 hr⁻¹). By contrast, nitrate recovery was slightly slower after the 4-hour shut-off period (0.15 hr⁻¹), compared to the 24-hour period (0.20 hr⁻¹). The system was relatively unaffected by power shut off as the bioreactor simply had more time to continue to degrade contaminants. Nitrate and perchlorate concentrations remained relatively constant over the 4-hour power shut off duration. Total nitrogen went from 0.4 to 0.5 mg-N/L, and perchlorate went from 15 to 19 µg/L in the finished water. Similarly, when power was shut off for 24 hours, total nitrogen went from 0.4 to 0.5 mg-N/L and perchlorate went from 11 to 10 µg/L in the finished water. The time for system recovery from hydrogen shut-off could be mitigated by operating the system in a batch recirculation mode. Additionally, at the time of the test there were 4 modules in each vessel that were originally designed for 7 modules. Increasing the number of reactors per vessel would also increase mass transfer and likely result in faster recovery. The recovery trends were similar to the tracer study trends indicative of high reactor dispersion and CSTR-type operation.

6.5 SAFETY

Safety concerns with this technology include use of a pressurized flammable gas, hydrogen, and other pressurized gases including nitrate and carbon dioxide. Generation of sulfide from sulfate can also cause inhalation hazards. There were no health and safety incidents reported during the Demonstration. Hydrogen leaks were detected by a sensor and the system was automatically shut down for maintenance. Hydrogen sulfide and LEL were monitored on a daily basis during the Optimization phase when a sulfide odor was noted by field staff. There were a few instances when the system was shut down due to a detection by the LEL sensor. However, no detections above the permissible exposure limit or threshold limit values were observed. The metric for this performance objective was met.

6.6 PERMIT COMPLIANCE

The California RWQCB reviewed the Demonstration Plan and approved discharge of 43,200 gallons per day of treated groundwater back into the ground via a French drain. The system influent was monitored for VOCs and the effluent was monitored for flow rate, pH, VOCs, total nitrogen, chloride, phosphate, TDS, and sulfate. These values were monitored and if detected,

were compared against permit requirements. There were no permit violations of California RWQCB permit number R8-2002-0033-038; therefore, this objective was met.

6.7 REGULATORY ACCEPTANCE

A letter of conditional acceptance for the MBfR for treatment of nitrate was received the CDPH on July 26, 2013 (Appendix I). APTwater has installed an MBfR system at the Cucamonga Valley Water District for full-scale treatment of nitrate. The system is called ARoNite™ that stands for Autotrophic Reduction of Nitrate. In December of 2011, the system became NSF 61-certified. The Optimization data gathered from this study were used to help develop the design and operations of the Cucamonga Valley Water District facility. This system is in the process of being permitted by CDPH for full-scale operation.

7.0 COST ASSESSMENT

The cost assessment was conducted for an MBfR treating nitrate and not perchlorate because the 6- $\mu\text{g/L}$ performance objective for perchlorate removal was not achieved. This section provides the cost assessment for a full-scale 1,000 gpm MBfR system under six scenarios. Each scenario was assessed during a 30-year life cycle. Since the MBfR process did not meet treatment objectives for perchlorate, the assessment focused solely on nitrate removal. The assessment was performed to obtain a generic cost data considering engineering, equipment, construction, and operational costs. The test data from the Rialto Well 22 site were used as a basis for developing the estimate. Comparisons were made between the MBfR and conventional IX and a packed bed or fixed-bed bioreactor (FXB).

7.1 COST MODEL

7.1.1 Capital Cost Estimation

The purpose of the capital cost estimate is to assess the generic project cost for system installation and construction. The capital cost includes equipment, installation, and construction, as well as standard line items to account for indirect costs. Equipment costs were obtained from system suppliers. Site installation and construction costs were estimated from the project team's experience on similar construction projects. Total installed cost and line items included in the cost estimate were calculated from the cost model in Table 7.1. A 30-year amortized cost was calculated from the total installed cost, assuming a 2.0% real discount rate obtained from the Office of Management and Budget.

It should be noted that for an objective comparison of capital costs, the following items on direct and indirect costs, which can vary greatly by site and/or project conditions, are not considered in this study:

- Land acquisition costs
- Major site improvement work, such as fill material or substantial clearing
- Raw water resource development and pumping/piping system
- Finished water storage
- Laboratory or staff office space
- Bringing utilities to/from the site (water, wastewater, power, communications)
- Environmental assessment of site
- Owner administration and legal fees

While effort was made to provide a realistic cost estimate, caveats must be placed that the installation costs are only applicable for systems operating at 1,000 gpm. For larger systems, though scaling of the costs may be directly proportional in some cases (i.e., electrical design), it is not always directly scaled. For example, with larger installations, significantly more design, labor, and materials would be required for structural design. Although a cost reduction might be observed based on an economy of scale, this reduction may be offset by the need for larger delivery trucks, fuel fees, additional labor, etc.

Table 7.1 Cost Estimate Model

Cost Element	Basis
Equipment Installed Cost	From System Suppliers
Civil and Construction Cost	Based on system footprint, including excavation, grading, and 2-foot concrete foundation
Piping and Mechanical Installed Cost	Assumed \$45/square foot
Electrical, Instrumentation, and Controls Installed Cost	Assumed 10% of the total installed cost for electrical and 2% for instrumentation and controls
Subtotal Direct Cost	Sum of the Above
Permit Fees and Sales Taxes	12% of Subtotal Direct Cost
Bond and Insurance	3% of Subtotal Direct Cost
Subtotal A	Subtotal Direct Cost + Permit Fees and Sales Taxes + Bond and Insurance
General Conditions	10% of Subtotal A
Contractor Overhead and Profit	15% of Subtotal A
Subtotal B	Subtotal A + General Conditions + Contractor Overhead and Profit
Contingency	25% of Subtotal B
Subtotal C	Subtotal B + Contingency
Engineering Design Services	10% of Subtotal C
Total Installed Cost	Subtotal C + Engineering Design Services

7.1.2 Operational Costs

Annualized operational costs are estimated for a 30-year plant life cycle with 2.0% real discount rate from Office of Management and Budget. Table 7.2 shows the calculation basis. Unit costs were based on quotes from equipment vendors and APTwater.

Table 7.2 Operations Cost Calculation Basis

Component	Units	Value
<i>MBfR Costs</i>		
Hydrogen, On-site Generation	\$/lb	0.59
Carbon Dioxide	\$/lb	0.24
Coagulant	\$/lb	1.1
75% Phosphoric Acid	\$/lb	0.85
Power	\$/kWh	0.12
Membrane Replacement Cycle	yr	10
Media Filter Replacement Cycle	yr	10

Component	Units	Value
<i>IX Resin Costs</i>		
IX Resin Replacement Cycle	yr	10
IX Regeneration Waste Discharge Fee	\$/gal	0.1
Salt for IX Regeneration	\$/ton	130

The following items are excluded from the operational cost estimate:

- Operation labor
- Raw and product water pumping
- Disinfection chemical
- Minor equipment and lighting power

7.1.3 MBfR System Design Basis

Three nitrate treatment goals were selected for a 1,000-gpm full-scale MBfR system: 1) 28 mg-N/L of influent and 4.0 mg N/L effluent, 2) 10 mg-N/L of influent and 6.8 mg-N/L effluent, and 3) 18 mg-N/L of influent and 6.8 mg-N/L of effluent. In all of these scenarios, a portion of the 1000-gpm stream would be treated by the MBfR to 0.5 mg-N/L and the remaining untreated water would be blended with the treated water to meet the above-stated effluent nitrate goal. Scenario 1 has a nitrate concentration similar to the previously published work on biological treatment technologies (Brown et al. 2008; Webster and Togna 2009) and is included in this study for comparison. Scenarios 2 and 3 were included to demonstrate mid-range and high-range nitrate loading, respectively. Scenario 2 has a nitrate concentration equal to that observed during the WVWD demonstration. Scenario 3 has a nitrate concentration in excess of the MCL of 10 mg-N/L to simulate treatment of a water source that would actually require treatment. The three treatment goals were applied to two MBfR system designs: a design using the same process used in the Demonstration (Scenarios 1, 2 and 3) and a design based on results from the Demonstration and APTwater's continued process development and optimization (Scenario 4, 5 and 6). The modified design was incorporated in the construction of the Cucamonga Valley Water District MBfR for nitrate treatment. It includes several enhancements to increase system efficiency and decrease wastewater generation. For example, scenarios 1 to 3 were designed similar to the pilot-scale field Demonstration where there was 100 percent excess hydrogen relative to the demand for biotransformation and fiber flushing to remove moisture and accumulated inert gases. By contrast, scenarios 4 to 6 were estimated assuming that hydrogen with 30 percent stoichiometric excess would be sufficient, similar to the full-scale system being installed at Cucamonga Valley Water District. The sparging frequency was also reduced from once every 12 hours in scenarios 1 to 3 to once every 24 hours in scenarios 4 to 6, which reduced the amount of wastewater generated in the modified design. The design bases for each scenario are shown in Table 7.3.

Table 7.3 MBfR System Design Parameters

Component	Units	Scenario					
		Based on Demonstration Results			Based on Optimized System Data from APTwater		
		1	2	3	4	5	6
Influent Water Quality							
Flow Rate	gpm	1,000	1,000	1,000	1,000	1,000	1,000
Temperature	Deg C	20	20	20	20	20	20
pH	SU	7.5	7.5	7.5	7.5	7.5	7.5
TDS	mg/L	260	260	260	260	260	260
Oxygen	mg/L	6	6	6	6	6	6
Sulfate	mg-SO ₄ /L	20	20	20	20	20	20
Nitrate	mg-N/L	6.3	10.2	18.1	6.3	10.2	18.1
	mg-NO ₃ /L	28	45	80	28	45	80
MBfR System Flow Distribution							
Total Flow Rate	gpm	1,000	1,000	1,000	1,000	1,000	1,000
Bypass Flow Rate	gpm	601	649	357	601	649	357
MBfR System Flow Rate	gpm	399	351	643	399	351	643
Operating Conditions							
Hydrogen Excess	%	100	100	100	30	30	30
Sparge Interval	hrs	12	12	12	24	24	24
Nitrate, MBfR Effluent	mg-N/L	0.5	0.5	0.5	0.5	0.5	0.5
	mg-NO ₃ /L	2.2	2.2	2.2	2.2	2.2	2.2
Nitrate, After Blending with Bypass Stream	mg-N/L	4.0	6.8	6.8	4.0	6.8	6.8
	mg-NO ₃ /L	17.7	30.0	30.0	17.7	30.0	30.0

The MBfR system consists of multiple vessel skids containing membrane modules and auxiliary equipment for aeration, filtration, and disinfection. A single vessel skid consists of two 32-membrane module basins. The footprint of one vessel skid is 24 feet by 8 feet. In this study, it is assumed that vessels would operate with a single-stage configuration. Each auxiliary skid has a compressed air system for membrane sparging, PLC controls and analyzers, aeration tank, and media filtration. The footprint of the auxiliary skid is 28 feet by 8 feet. Figure 7.1 shows a three-dimensional (3-D) rendering of the exemplary MBfR system with one vessel skid and one auxiliary skid. Figure 7.2 shows a process flow diagram of a typical MBfR system. Table 7.4 summarizes the system configuration for each scenario.

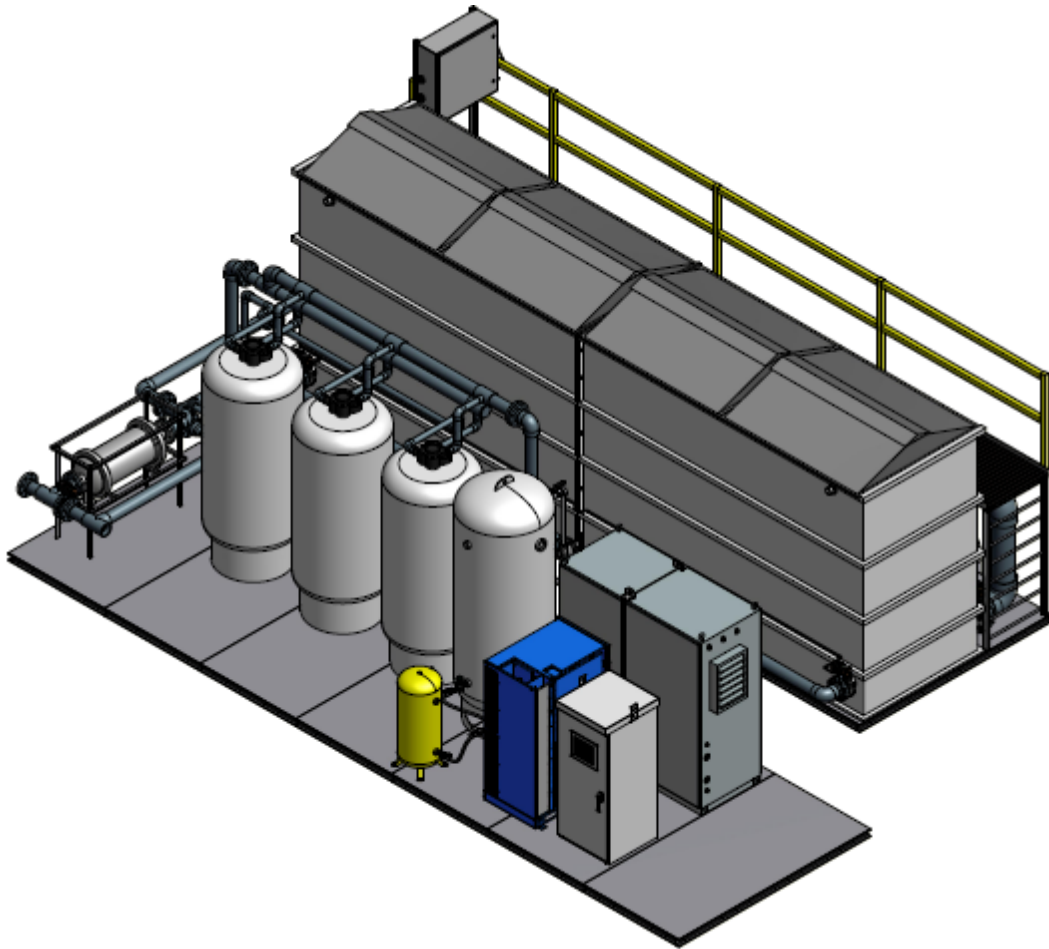
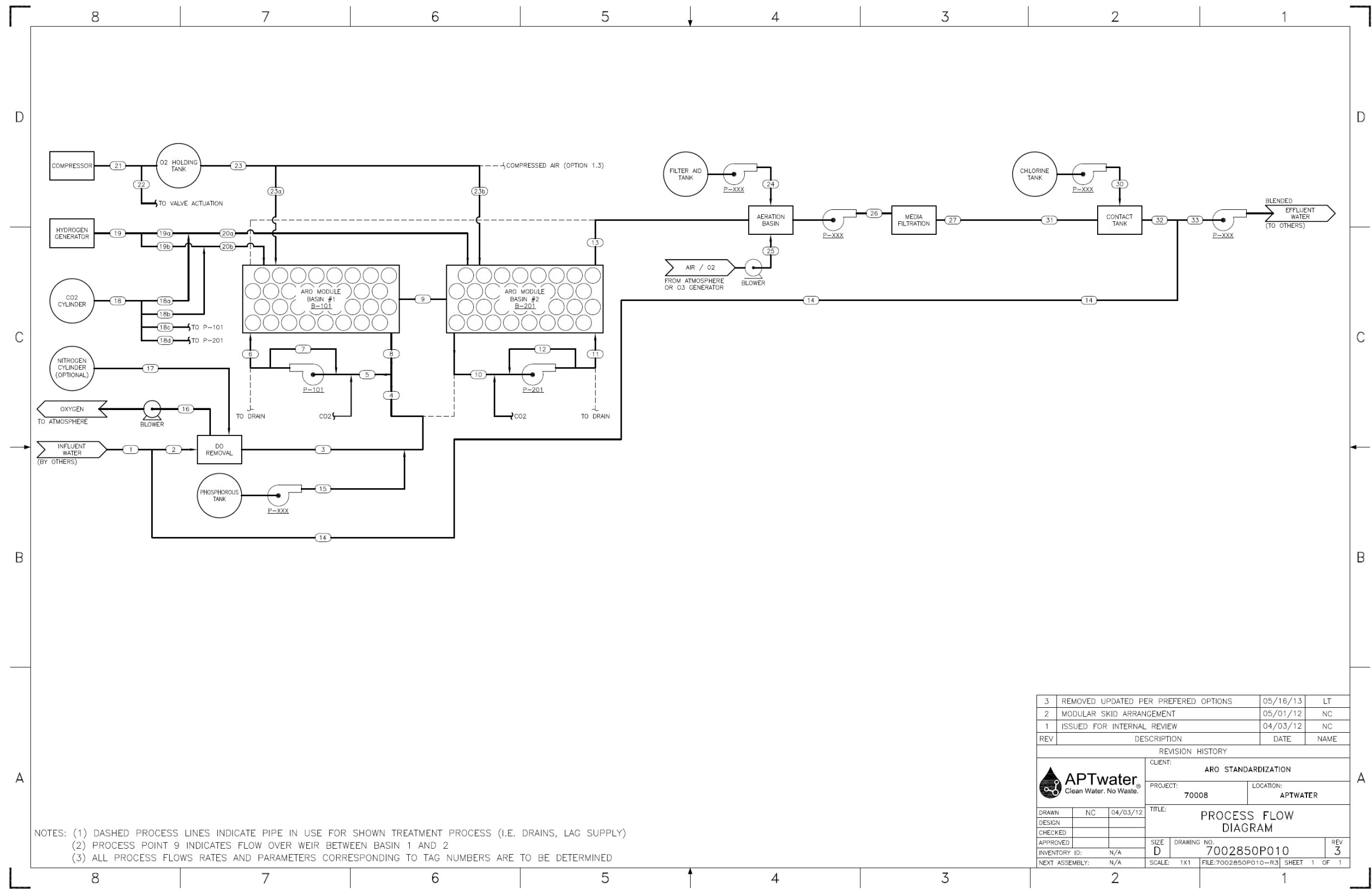

Figure 7.1 3-D Rendering of Exemplary MBfR System



NOTES: (1) DASHED PROCESS LINES INDICATE PIPE IN USE FOR SHOWN TREATMENT PROCESS (I.E. DRAINS, LAG SUPPLY)
 (2) PROCESS POINT 9 INDICATES FLOW OVER WEIR BETWEEN BASIN 1 AND 2
 (3) ALL PROCESS FLOWS RATES AND PARAMETERS CORRESPONDING TO TAG NUMBERS ARE TO BE DETERMINED

REV	DESCRIPTION	DATE	NAME
3	REMOVED UPDATED PER PREFERED OPTIONS	05/16/13	LT
2	MODULAR SKID ARRANGEMENT	05/01/12	NC
1	ISSUED FOR INTERNAL REVIEW	04/03/12	NC

		CLIENT: ARO STANDARDIZATION	
PROJECT: 70008		LOCATION: APTWATER	
TITLE: PROCESS FLOW DIAGRAM			
DRAWN: NC DESIGN: 04/03/12 CHECKED:	SIZE: D DRAWING NO.: 7002850P010 INVENTORY ID: N/A NEXT ASSEMBLY: N/A	SCALE: 1X1 FILE: 7002850P010-R3	REV: 3 SHEET 1 OF 1

Figure 7.2 Process Flow Diagram of MBfR System

Table 7.4 MBfR System Configurations

	Scenario					
	Based on Demonstration Results			Based on Optimized System Data from APTwater		
	1	2	3	4	5	6
Minimum Quantity of Modules	163	210	644	93	120	368
Modules with Redundancy	192	256	672	128	160	384
Quantity of Module Skids	3	4	11	2	3	6
Quantity of Auxiliary Skids	2	2	3	2	2	3
Construction Area Required (m²)	1024	1216	2784	832	1024	1824

7.1.4 Ion Exchange System Design Basis

IX is a common water treatment process used to reduce various ionic species in water and wastewater. In this study, the cost of nitrate removal by the IX system was estimated and compared to the MBfR system. Table 7.5 summarizes design parameters of a regenerable IX system. The IX system was designed to treat 1,000 gpm with the same treatment goals established for Scenarios 1 to 3 (Table 7.5). The IX system consists of three IX vessels along with pre-filter skids, a brine regeneration system, and a regeneration waste storage system.

Table 7.5 IX System Design Parameters

Component	Units	Scenario		
		1	2	3
Influent Water Quality				
Flow Rate	gpm	1,000	1,000	1,000
Temperature	Deg C	20	20	20
pH	SU	7.5	7.5	7.5
Total Dissolved Solids	mg/L	260	260	260
Oxygen	mg/L	6	6	6
Sulfate	mg-SO ₄ /L	20	20	20
Nitrate	mg-N/L	6.3	10.2	18.1
	mg-NO ₃ /L	28	45	80
IX Flow Distribution				
Total Flow Rate	gpm	1000	1000	1000
Bypass Flow Rate	gpm	280	280	280
IX Flow Rate	gpm	720	720	720
Effluent Treatment Goals (post-blending)				
Nitrate	mg-N/L	4.0	6.8	6.8
	mg-NO ₃ /L	17.7	30.0	30.0

7.2 COST DRIVERS

The main drivers for the capital cost are the nitrate concentration in influent water and the target nitrate concentration in effluent water. Since the MBfR system can achieve an effluent nitrate concentration down to 0.5 mg N/L or less, it is not necessary to treat the entire influent stream with MBfR to meet target effluent concentrations. Hence, part of influent water can bypass the MBfR system and be blended with the MBfR effluent to meet the target nitrate concentration. The nitrate concentration in the influent water and the target nitrate concentration in the effluent water will eventually determine the bypass ratio of influent water to the MBfR system. A higher bypass ratio requires a smaller equipment size, which will reduce the capital cost.

One of the main drivers for the operational cost of the MBfR system is electricity for recirculation pumps. The electricity for the recirculation pump can account for up to 60% of the operational cost. In general, the recirculation flow increases in proportion to the MBfR system size. As described above, the system size is largely affected by the MBfR system bypass ratio, and the MBfR system bypass ratio will be mostly determined by influent nitrate concentrations and the target effluent nitrate concentrations. Hence, the nitrate concentrations are the most important factor affecting both the capital and operational costs of the MBfR system. Consumption of process chemicals such as hydrogen gas, carbon dioxide gas, and phosphoric acid are other important factors for the operation cost. The chemicals are critical for the biological reduction of DO and nitrate, and need to be supplied to the system continuously. The chemical cost, particularly hydrogen and carbon dioxide, account for a significant portion of the MBfR system operational costs.

7.3 COST ANALYSIS

7.3.1 MBfR System

Table 7.6 shows the capital cost estimate for the MBfR system under different operating scenarios. Scenarios 1 to 3 considered the design that was used for the Demonstration project. Scenarios 4 to 6 are based on the modified MBfR design, which enhanced the system efficiency and reduced wastewater generation. The total installed cost estimate for the MBfR system ranged from \$3,757,100 for Scenario 4 to \$13,635,500 for Scenario 3, and the 30-year amortized installed cost ranged from \$167,800 for Scenario 4 to \$608,900 for Scenario 3. In general, the total installed cost was related to the MBfR bypass ratio and it increased as the MBfR bypass ratio decreased. As the MBfR system bypass ratio increased, the system required a smaller equipment size that reduced the capital cost in turn.

Table 7.6 MBfR Capital Costs

Cost Element	Scenario 1	Scenario 2	Scenario 3	Scenario 4	Scenario 5	Scenario 6
Equipment Installed Cost	\$ 1,988,100	\$ 2,404,300	\$ 5,444,400	\$ 1,466,200	\$ 1,812,400	\$ 3,416,600
Civil and Construction Cost	\$ 139,300	\$ 165,400	\$ 378,600	\$ 113,200	\$ 139,300	\$ 248,100
Piping and Mechanical Installed Cost	\$ 95,700	\$ 113,600	\$ 260,000	\$ 77,700	\$ 95,700	\$ 170,400
Electric and I&C Installed Cost	\$ 300,000	\$ 356,300	\$ 815,700	\$ 243,800	\$ 300,000	\$ 534,400
Subtotal Direct Cost	\$ 2,523,000	\$ 3,039,500	\$ 6,898,600	\$ 1,900,800	\$ 2,347,300	\$ 4,369,400
Permit Fees and Sales Taxes	\$ 302,800	\$ 364,800	\$ 827,900	\$ 228,100	\$ 281,700	\$ 524,400
Bond and Insurance	\$ 75,700	\$ 91,200	\$ 207,000	\$ 57,100	\$ 70,500	\$ 131,100
Subtotal A	\$ 2,901,400	\$ 3,495,400	\$ 7,933,400	\$ 2,185,900	\$ 2,699,400	\$ 5,024,800
General Conditions	\$ 290,200	\$ 349,600	\$ 793,400	\$ 218,600	\$ 270,000	\$ 502,500
Contractor Overhead and Profit	\$ 435,300	\$ 524,400	\$ 1,190,000	\$ 327,900	\$ 404,900	\$ 753,800
Subtotal B	\$ 3,626,700	\$ 4,369,200	\$ 9,916,700	\$ 2,732,400	\$ 3,374,200	\$ 6,281,000
Contingency	\$ 906,700	\$ 1,092,300	\$ 2,479,200	\$ 683,100	\$ 843,600	\$ 1,570,300
Subtotal C	\$ 4,533,400	\$ 5,461,500	\$ 12,395,900	\$ 3,415,500	\$ 4,217,700	\$ 7,851,200
Engineering Design Services	\$ 453,400	\$ 546,200	\$ 1,239,600	\$ 341,600	\$ 421,800	\$ 785,200
Total Installed Cost	\$ 4,986,700	\$ 6,007,700	\$ 13,635,500	\$ 3,757,100	\$ 4,639,500	\$ 8,636,300
Installed Cost, 30 Year Amortized	\$ 222,700	\$ 268,300	\$ 608,900	\$ 167,800	\$ 207,200	\$ 385,700

Table 7.7 MBfR Operation Cost

Cost Element	Scenario 1	Scenario 2	Scenario 3	Scenario 4	Scenario 5	Scenario 6
Electricity	\$ 90,900	\$ 114,400	\$ 269,300	\$ 67,300	\$ 78,900	\$ 162,800
Coagulant	\$ 3,800	\$ 3,400	\$ 6,200	\$ 3,800	\$ 3,400	\$ 6,200
Phosphoric Acid	\$ 4,400	\$ 3,900	\$ 7,100	\$ 4,400	\$ 3,900	\$ 7,100
Hydrogen	\$ 18,200	\$ 23,700	\$ 72,600	\$ 5,900	\$ 7,600	\$ 23,300
Carbon Dioxide	\$ 5,500	\$ 7,900	\$ 26,300	\$ 12,100	\$ 17,600	\$ 58,500
Aeration	\$ 13,200	\$ 16,100	\$ 42,300	\$ 7,200	\$ 6,900	\$ 11,700
Membrane Replacement	\$ 13,000	\$ 16,400	\$ 39,300	\$ 9,400	\$ 11,300	\$ 23,600
Annual Operation Cost, 30 Year Amortized	\$ 149,000	\$ 185,800	\$ 463,100	\$ 110,100	\$ 129,600	\$ 293,200

Table 7.8 MBfR Annual Project Cost

Cost Element	Scenario 1	Scenario 2	Scenario 3	Scenario 4	Scenario 5	Scenario 6
Installed Cost, 30 Year Amortized	\$ 222,700	\$ 268,300	\$ 608,900	\$ 167,800	\$ 207,200	\$ 385,700
Annual Operation Cost, 30 Year Amortized	\$ 149,000	\$ 185,800	\$ 463,100	\$ 110,100	\$ 129,600	\$ 293,200
Annual Total Project Cost, 30 Year Amortized (\$)	\$ 371,700	\$ 454,100	\$ 1,072,000	\$ 277,900	\$ 336,800	\$ 678,900
Annual Total Project Cost, 30 Year Amortized (\$/MG)	\$ 706	\$ 863	\$ 2,037	\$ 528	\$ 640	\$ 1,290

Scenarios 1 to 3 considered the design that was used for the Demonstration. Scenarios 4 to 6 are based on the modified MBfR design that enhanced the system efficiency and reduced wastewater generation. The total installed cost estimate for the MBfR system ranged from \$3,757,100 for Scenario 4 to \$13,635,500 for Scenario 3 and the 30-year amortized installed cost ranged from \$167,800 for Scenario 4 to \$608,900 for Scenario 3. In general, the total installed cost was related with the MBfR bypass ratio and it increased as the MBfR bypass ratio decreased.

Table 7.7 shows operational costs for the MBfR system. Those costs ranged from \$110,100 for Scenario 4 to \$463,100 for Scenario 3. Electrical power was the major component of the operational costs, accounting for approximately 60 percent of the cost. A major power consumer of the MBfR system is the recirculation pump for the MBfR vessels. Recirculation flow rate increases as the bypass ratio decreases (i.e., as the MBfR system treats more influent water), resulting in higher operational cost. The cost for chemicals including hydrogen is the other important parameter accounting for 20 to 30 percent of the operational cost.

Table 7.8 presents total 30-year amortized project costs for the MBfR system. The 30-year amortized project cost ranges from \$277,900 for Scenario 4 to \$1,072,000 for Scenario 3.

7.3.2 IX System

For the IX system, the capital cost does not change between the scenarios since the same influent stream is treated by IX while the regeneration cycle is varied by the nitrate loading. Table 7.9 shows the capital cost estimate for the IX system, and for all three scenarios the total installed cost was \$4,510,800, with a 30-year amortized installed cost of \$201,500.

Table 7.9 IX Capital Cost

Cost Element	Scenarios 1, 2, and 3
Equipment Installed Cost	\$ 1,613,700
Civil and Construction Cost	\$ 216,900
Piping and Mechanical Installed Cost	\$ 151,700
Electric and I&C Installed Cost	\$ 300,000
Subtotal Direct Cost	\$ 2,282,100
Permit Fees and Sales Taxes	\$ 273,900
Bond and Insurance	\$ 68,500
Subtotal A	\$ 2,624,400
General Conditions	\$ 262,500
Contractor Overhead and Profit	\$ 393,700
Subtotal B	\$ 3,280,500
Contingency	\$ 820,200
Subtotal C	\$ 4,100,700

Cost Element	Scenarios 1, 2, and 3
Engineering Design Services	\$ 410,100
Total Installed Cost	\$ 4,510,800
Installed Cost, 30 Year Amortized	\$ 201,500

Table 7.10 shows the operational cost estimate for the IX system. The 30-year amortized operation cost ranges from \$1,261,800 for Scenario 1 to \$1,620,000 for Scenario 3. IX regeneration waste discharge accounts for the major portion of the cost. The cost generally increases as nitrate loading to the IX system increases. The 30-year amortized annual project costs are estimated at \$1,463,300 for Scenario 1, \$1,466,600 for Scenario 2, and \$1,821,500 for Scenario 3 as shown in Table 7.11.

Table 7.10 IX Operational Cost

	Scenario 1	Scenario 2	Scenario 3
Salt	\$ 39,400	\$ 50,900	\$ 95,000
Prefilter	\$ 10,800	\$ 10,800	\$ 10,800
IX Resin Replacement	\$ 2,500	\$ 2,500	\$ 2,500
IX Regeneration Waste Disposal	\$ 1,209,100	\$ 1,200,900	\$ 1,511,700
Annual Operation Cost, 30 Year Amortized	\$ 1,261,800	\$ 1,265,100	\$ 1,620,000

Table 7.11 IX Annual Project Cost

	Scenario 1	Scenario 2	Scenario 3
Installed Cost, 30 Year Amortized	\$ 201,500	\$ 201,500	\$ 201,500
Annual Operation Cost, 30 Year Amortized	\$ 1,261,800	\$ 1,265,100	\$ 1,620,000
Annual Project Cost, 30 Year Amortized	\$ 1,463,300	\$ 1,466,600	\$ 1,821,500
Annual Total Project Cost, 30 Year Amortized (\$/MG)	\$ 2,781	\$ 2,787	\$ 3,462

7.3.3 Comparison of the Technologies

A comparison between the MBfR system and the IX system shows that the MBfR system has higher capital cost for scenarios 1 through 3 (Table 7.12). However, under the given operational cost calculation basis shown in Table 7.2, the operational cost of the IX is much higher than that of the MBfR. Especially for the IX system, the operational cost is largely affected by the wastewater discharge, and costs can vary widely by site. While wastewater from the MBfR system, which is mostly from media backwash waste and MBfR sparging water, can be discharged through the municipal sanitary sewer after removing some of suspended solids, wastewater generated during IX regeneration cannot be directly discharged to the municipal sewer mainly due to the high salt concentration. Wastewater discharge cost can be extremely high and this can inhibit the implementation of IX technology. For example, for the Rialto Well

22 site, hauling IX regeneration wastewater off-site to the nearest treatment facility was approximately \$0.10 per gallon. Considering the amount of regeneration wastewater from the IX system, the 30-year amortized annual operation cost for regeneration wastewater was estimated to be \$1,209,000 for Scenario 1, \$1,201,900 for Scenario 2, and \$1,511,700 for Scenario 3. These costs alone are higher than the total project costs for the MBfR system when compared under the same operational scenarios. An evaporation pond, a zero liquid discharge system, or an on-site waste reduction facility can be other options to handle the IX regeneration waste. This decision can be made only after careful consideration of all site-specific conditions, including availability of the discharge sites, proximity to the treatment facility, land availability, land cost and electric cost. The IX regeneration waste handling cost is the main driver for the IX system, which could affect the process selection between the IX and the MBfR. The MBfR system can be a viable option for nitrate removal especially when it is difficult to find an economical solution to handle the IX regeneration wastewater.

The MBfR was also compared with a previous study, ESTCP project 0544, “Direct Fixed-Bed Biological Perchlorate Destruction Demonstration” (Brown et al. 2008). This project estimated the cost of a FXB for perchlorate removal. For the comparison of the two studies, it should be first noted that the FXB system project cost is estimated in 2008 based on a 2.8 percent discount rate, while the MBfR system in this study is estimated in 2013 based on a 2.0 percent discount rate. In the FXB system, the main cost drivers were DO and nitrate concentrations, similar to the MBfR system, even though the main target of the technology was perchlorate. The FXB also treated the entire 1,000 gpm flow stream. In the FXB system, due to the very low level of perchlorate in influent water and low electron donor demand, the perchlorate concentration affects the project cost very little. Figure 7.3 shows a comparison between the MBfR, IX, and FXB systems for a 1,000 gpm system and water quality outlined under scenario 1. Based on 1,000 gpm influent flow with 28 mg/L of nitrate in influent water, the 30-year amortized project cost of the FXB system was \$384,000, which is similar to the 30-year amortized project cost of \$371,700 for the MBfR system tested at the Demonstration plant (Scenario 1). However, when compared with the modified MBfR design (Scenario 4), the MBfR system shows approximately 30% lower project cost of \$277,900. The comparison with the FXB and the IX implies that MBfR cost can be lower or equivalent to competing biological reduction technologies and thus can be a competitive technology for nitrate removal.

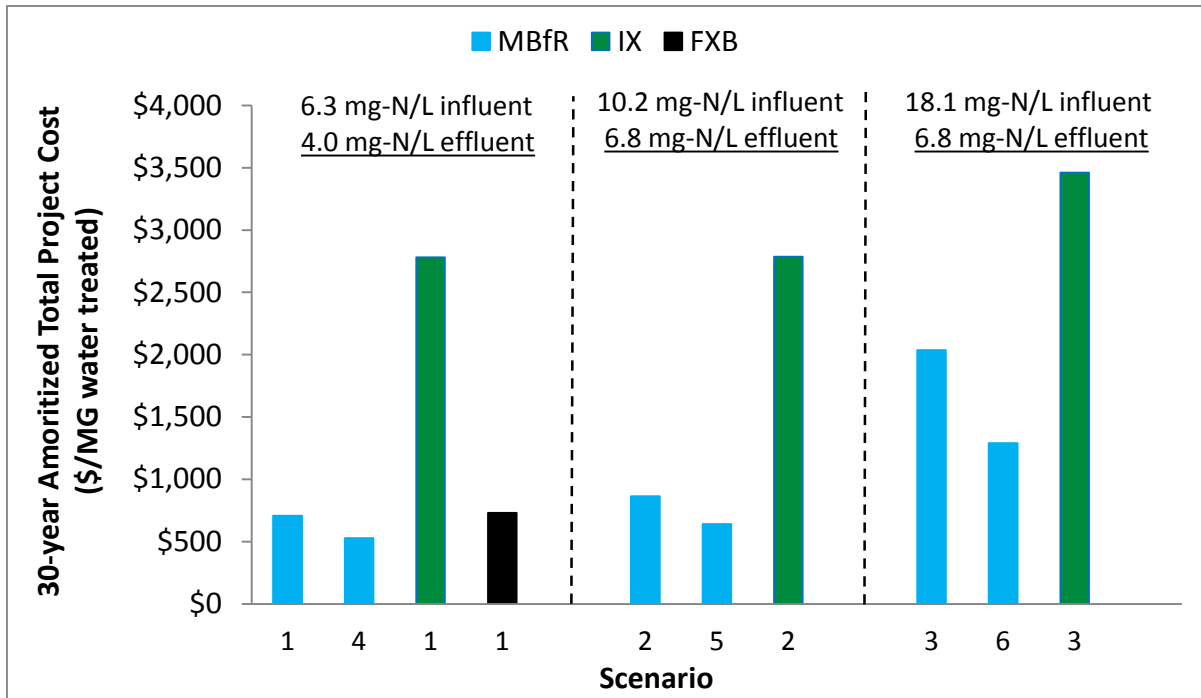

Figure 7.3 Comparison of MBfR 30-Year Amortized Capital and Operating Costs with IX and FXB operating at 1,000 gpm

8.0 IMPLEMENTATION ISSUES

The MBfR system for treatment of nitrate and production of potable water was shown to be possible and effective. The MBfR system is ready for applications involving treatment of drinking water sources contaminated with nitrate. Implementation for treatment of nitrate requires meeting necessary permitting regulations and that the key findings from this Demonstration are integrated into a full-scale process. The MBfR can be designed to treat source waters with different nitrate concentrations. Sulfate will not affect treatment of nitrate because the MBfR is not operated under sufficiently reducing conditions when treating nitrate. Treatment of perchlorate to less than 6 µg/L was not possible and requires further development. The parallel research conducted by Arizona State University provides possible ways to address this current limitation (Rittmann et al. 2013).

8.1 REGULATIONS AND PERMITS

All potable water treatment systems must follow the SDWA regulations established by the USEPA. Specific regulations under the NPDWR are the SWTR including the interim, Long Term 1, and Long Term 2 Enhanced SWTR; Total Coliform Rule; URCMR 1; FBRR; Stage 1 and Stage 1 DBP Rules; Groundwater Rule; and the Lead and Copper Rule. Additional state requirements and regulations may apply if the state is provided primacy to implement the regulations. The regulatory agency within the State of California that has been delegated primacy is the CDPH. The CDPH has set more stringent primary and secondary MCLs under Title 22 of the CCR (Social Security), Division 4 (Environmental Health). The CDPH is responsible for certifying drinking water treatment technologies pursuant to California Health and Safety Code Section 116830. The CDPH is also responsible for permitting drinking water supplies.

All applicable Federal and State regulations and requirements must be met for a full-scale MBfR system for potable water treatment including, but are not limited to:

- Compliance with primary drinking water standards for nitrite.
- Filtration to remove suspended solids and bacteria.
- Disinfection to ensure that the potable water supply does not contain pathogenic bacteria (e.g., *E. coli*, fecal coliforms, and total coliforms) or elevated levels of heterotrophic bacteria.

While there are currently no Federal regulations for perchlorate in place, the USEPA has established an Interim Drinking Water Health Advisory of 15 µg/L. In February 2011 EPA released the determination that perchlorate met the SDWA criteria for regulation and EPA is currently in the process of establishing an MCL (Lehman and Subramani 2011). The CDPH has developed rules that are more stringent and established a State MCL of 6 µg/L as of October 2007.

8.2 END-USER CONCERNS

The results of this Demonstration study showed that: 1) the MBfR bioreactor treatment system provided consistent and robust nitrate removal and high but incomplete perchlorate removal; 2)

aeration, media filtration, and disinfection provided effective post-treatment but filtration required further optimization; 3) system operation was straightforward, requiring no specialized training; 4) the bacterial communities in these systems were indigenous organisms that formed a biofilm within approximately one month; and 5) total water production costs are lower than conventional IX treatment. A full-scale MBfR system for nitrate treatment and potable water generation is in the process of being permitted at Cucamonga Valley Water District. The combination of data from this Demonstration project in conjunction with regulatory approval of a full-scale system will support additional work and willingness to design and operate this technology full-scale.

An end-user concern is use of hydrogen, a flammable gas. The data presented herein demonstrated that this issue was easily managed and did not necessitate extraordinary efforts. Specifically the following observations and actions were part of this Demonstration:

- Hydrogen was supplied using an on-site generation system with back-up cylinders. The cylinders were contained on a gas-supply pad that stabilized and manifolded the supply gases together.
- Flammable gas/no-smoking placards were used.
- LEL sensors stopped the system when hydrogen was detected.
- Liquid nitrogen was supplied in a commercially available dewar. From a cold surface hazard perspective, liquid nitrogen is handled the same as liquid oxygen at hospitals and other commercial facilities.
- Liquid carbon dioxide was supplied in cylinders similar to hydrogen back-up cylinders. These were secured in the same containment area as hydrogen and nitrogen.

8.3 PROCUREMENT

APTwater provides a commercially available MBfR skid system, called ARoNite™. The system includes MBfR vessels and auxiliary equipment, which may include downstream processing (aeration, media filtration, disinfection), based on customer requirements. Procurement of compressed or liquefied gases can be accomplished through a variety of national vendors. Gas generators are specialized pieces of equipment but are available from several manufacturers. Gas manifolds and distribution systems are not off-the-shelf and will require engineering design and custom fabrication.

9.0 REFERENCES

- Adham, S., K.P. Chiu, G. Lehman, B.E. Rittmann, and J. Chung. 2005. Novel membrane biofilm reactor for groundwater treatment and remediation. National Water Research Institute.
- Adham, S., T. Gillogly, G. Lehman, B. Rittmann, and R. Nerenberg. 2004. *Membrane Biofilm Reactor Process for Nitrate and Perchlorate Removal*. Denver, Colo.: AwwaRF.
- APHA, A., and WEF. 1998. Standard Methods for the Examination of Water and Wastewater. 18th ed. Washington, DC: APHA.
- Brandhuber, P., S. Clark, and K. Morley. 2009. A Review of perchlorate occurrence in public drinking water systems. *Journal AWWA* 101 no. 11: 63-73.
- Brown, J., C.V. Lauderdale, G. Estavo, A. Ettori, W. Shih, S. Poust, S. Walker, L. Raskin, G. Upadhyaya, X. Li, and E. Morgenroth. 2008. Final Report: Direct fixed-bed biological perchlorate destruction demonstration. ESTCP project ER-0544. Environmental Security Technology Certification Program.
- CDPH. 1997. Policy Memo 97-005 Policy Guidance for Direct Domestic Use of Extremely Impaired Sources. Internal memorandum. California Department of Health Services. <http://www.cdph.ca.gov/certlic/drinkingwater/Documents/DWdocuments/memo97-005.pdf>.
- Chung, J., R. Brown, and B. Rittmann. 2008a. Bioreduction of trichloroethene using a hydrogen-based membrane biofilm reactor. *Environmental Science & Technology* 42 no. 2: 477-483.
- Chung, J., X. Li, and B.E. Rittman. 2006a. Bio-reduction of arsenate using a hydrogen-based membrane biofilm reactor. *Chemosphere* 65 no. 1: 24-34.
- Chung, J., R. Nerenberg, and B.E. Rittmann. 2006b. Bio-reduction of selenate by a hydrogen-based membrane biofilm reactor. *Environmental Science & Technology* 40 no. 5: 1664-1671.
- Chung, J., and B.E. Rittmann. 2007. Bio-reductive dechlorination of 1,1,1-trichloroethane and chloroform using a hydrogen-based membrane biofilm reactor. *Biotechnology and Bioengineering* 97 no. 1: 52-60.
- . 2008. Simultaneous bio-reduction of trichloroethene, trichloroethane, and chloroform using a hydrogen-based membrane biofilm reactor. *Water Science and Technology* 58 no. 3: 495-501.
- Chung, J., B.E. Rittmann, W.F. Wright, and R.H. Bowman. 2007. Simultaneous bio-reduction of nitrate, perchlorate, selenate, chromate, arsenate, and dibromochloropropane using a hydrogen-based membrane biofilm reactor. *Biodegradation* 18 no. 2: 199-209.
- Chung, J., H.W. Ryu, M. Abbaszadegan, and B.E. Rittmann. 2006c. Community structure and function in an H₂-based membrane biofilm reactor capable of bio-reduction of selenate and chromate. *Applied Microbiology and Biotechnology* 72 no. 6: 1130-1339.
- Chung, J.A., Z. Chen, and B.E. Rittmann. 2008b. Bio-reduction of N-nitrosodimethylamine (NDMA) using a hydrogen-based membrane biofilm reactor. *Chemosphere* 70 no. 3: 516-520.
- Chung, J.C., R. Nerenberg, C. Torres, and B.E. Rittmann. 2006d. Bio-reduction of soluble chlormate using a hydrogen-based membrane biofilm reactor. *Water Research* 40 no. 8: 1634-1642.
- Downing, L.S., and R. Nerenberg. 2007. Kinetics of microbial bromate reduction in a hydrogen-oxidizing, denitrifying biofilm reactor. *Biotechnology and Bioengineering* 98 no. 3: 543-550.

- GAO. 2010. Perchlorate: Occurrence is Widespread but at Varying Levels; Federal Agencies Have Taken Some Actions to Respond to and Lessen Releases.
- GeoSyntec. 2005. Draft Remedial Investigation Report, Prepared for Goodrich Corporation.
- . 2007. Goodrich Corporation progress report for the month of September, 2007, 160-acre Parcel, Rialto, California.
- Hasar, H. 2009. Simultaneous removal of organic matter and nitrogen compounds by combining a membrane bioreactor and a membrane biofilm reactor. *Bioresource Technology* 100 no. 10: 2699-26705.
- Hatzinger, P.B. 2005. Perchlorate biodegradation for water treatment. *Environ Sci Technol* 39 no. 11: 239A-247A.
- Lee, L.C., and B.E. Rittmann. 2002. Applying a novel autohydrogenotrophic hollow-fiber membrane biofilm reactor for denitrification of drinking water. *Water Resources* 36 no. 8: 2040-2052.
- Lehman, S.G., and A. Subramani. 2011. *State-of-Science on Perchlorate Treatment Technologies and Regulations*. Denver, Colorado: Water Research Foundation.
- Levenspiel, O. 1962. *Chemical Reaction Engineering. An Introduction to the Design of Chemical Reactors*. New York.: John Wiley and Sons.
- Logan, B.E., and D. LaPoint. 2002. Treatment of perchlorate- and nitrate-contaminated groundwater in an autotrophic, gas phase, packed-bed bioreactor. *Water Res* 36 no. 14: 3647-53.
- Logan, B.E., B. Min, K. Kim, J. Miller, D. LaPoint, J. Batista, J. Liu, P.J. Evans, A. Chu, and S. Price. 2004. Bioreactor systems for treating perchlorate-contaminated water: bench- and pilot- scale investigations. AwwaRF.
- Miller, J.P., and B.E. Logan. 2000. Sustained perchlorate degradation in an autotrophic, gas-phase, packed-bed bioreactor. *Environmental Science & Technology* 34 no. 14: 3018-3022.
- Nerenberg, R., Y. Kawagoshi, and B. Rittmann. 2008. Microbial ecology of a perchlorate-reducing, hydrogen-based membrane biofilm reactor. *Water Research* 42 no. 4: 1151-1159.
- Nerenberg, R., and B.E. Rittmann. 2004. Hydrogen-based, hollow-fiber membrane biofilm reactor for reduction of perchlorate and other oxidized contaminants. *Water Science and Technology* 49 no. 11-12: 223-230.
- Nerenberg, R., B.E. Rittmann, T.E. Gillogly, G.E. Lehman, and S.S. Adham. 2003. Perchlorate reduction using a hollow-fiber membrane biofilm reactor: kinetics, microbial ecology, and pilot-scale studies. In *International Battelle Conference*, C-08.
- Nerenberg, R., B.E. Rittmann, and I. Njam. 2002. Perchlorate reduction in a hydrogen-based membrane-biofilm reactor. *J. AWWA* 94 no. 11: 103-114.
- Rittmann, B., and P. McCarty. 2001. *Environmental Biotechnology: Principles and Applications* Boston: McGraw-Hill
- Rittmann, B., and V.L. Snoeyink. 1984. Achieving biologically stable drinking water. *Journal AWWA* 76: 106-114.
- Rittmann, B.E., and K.C. Lee. 2002. Hollow-fiber membrane biofilm reactor for autohydrogenotrophic treatment of water, vol. 6,387,262.
- Rittmann, B.E., R. Nerenberg, K.C. Lee, I. Najm, T.E. Gillogly, G.E. Lehman, and S.S. Adham. 2004. Hydrogen-based hollow-fiber membrane biofilm reactor (HFMBfR) for reducing oxidized contaminants. *Water Science and Technology: Water Supply* 4 no. 1: 127-133.

- Rittmann, B.E., A. Ontiveros-Valencia, H.-P. Zhao, Y. Tang, B. Kim, S. van Ginkel, and R. Krajmalnik-Brown. 2013. Nitrate and perchlorate destruction using the membrane biofilm reactor: Analysis of the microbial ecology and biofilm development of side reactors and pilot reactor modules, bench-scale studies, and mechanistic modeling. ESTCP Project ER-200541.
- Schneider, O.D., M.W. LeChevallier, P.J. Evans, J. Smith, R. Chappell, L.A. Weinrich, P. Jjemba, S. Diehl, and M. Kreminskaya. 2013. An operational definition of biostability in drinking water. In *AWWA Biological Treatment Symposium*. Denver.
- Stumm, W., and J.J. Morgan. 1996. *Aquatic Chemistry: Chemical Equilibria and Rates in Natural Waters*. 3rd ed. ed. Hoboken, NJ: Wiley Science.
- Urbansky, E.T. 1998. Perchlorate chemistry: implications of analysis and remediation. *Bioremediation Journal* 2 no. 2: 81-95.
- USEPA. 1991. Guidance manual for compliance with the filtration and disinfection requirements for public water systems using surface water sources. <http://water.epa.gov/lawsregs/rulesregs/sdwa/swtr/upload/guidsws.pdf>.
- . 1998. *External Review Draft Perchlorate Environmental Contamination: Toxicological Review and Risk Characterization Based on Emerging Information*. Washington, D.C.: USEPA Office of Research and Development.
- . 2003. LT1ESWTR Disinfection Profiling and Benchmarking. EPA Office of Water.
- . 2005. Perchlorate (ClO₄⁻) and Perchlorate Salts. Integrated Risk Information System (IRIS). U.S. Environmental Protection Agency.
- . 2011. Summary of perchlorate and volatile organic compounds in groundwater, June/July 2011, BF Goodrich Site, San Bernadino County, California.
- Van Ginkel, S.W., C.H. Ahn, M. Badruzzaman, D.J. Roberts, S.G. Lehman, S.S. Adham, and B.E. Rittmann. 2008. Kinetics of nitrate and perchlorate reduction in ion-exchange brine using the membrane biofilm reactor (MBfR). *Water Res* 42 no. 15: 4197-205.
- Wang, H.-C., A. Eaton, and B. Narloch. 2002. *National Assessment of Perchlorate Contamination Occurrence*. Denver, Colorado: AWWA and the Awwa Research Foundation.
- Webster, T.S., and P. Togna. 2009. Final report: Demonstration of a full-scale fluidized bed bioreactor for the treatment of perchlorate at low concentrations in groundwater. Environmental Security Technology Certification Program.
- Wooldenden, L.R., and D. Kadhim. 2005. Geohydrology and Water Chemistry in the Rialto-Colton Basin, San Bernadino County, California.
- Xia, S., H. Li, Z. Zhang, Y. Zhang, X. Yang, R. Jia, K. Xie, and X. Xu. 2011. Bioreduction of para-chloronitrobenzene in drinking water using a continuous stirred hydrogen-based hollow fiber membrane biofilm reactor. *Journal of Hazardous Materials* 30 no. 192: 593-598.
- Xia, S., F. Zhong, Y. Zhang, H. Li, and X. Yang. 2010. Bio-reduction of Nitrate from Groundwater Using a Hydrogen-Based Membrane Biofilm Reactor. *Journal of Environmental Sciences* 22 no. 2: 257-262.
- Zhao, H.-P., S.V. Ginkel, Y. Tang, D.-W. Kang, B. Rittmann, and R. Krajmalnik-Brown. 2011. Interactions between perchlorate and nitrate reductions in the biofilm of a hydrogen based MBfR. *Environmental Science & Technology* 45 no. 23: 10155-10162.
- Ziv-El, M., and B. Rittmann. 2009. Systematic evaluation of nitrate and perchlorate bioreduction kinetics in hroundwater using a hydrogen-based membrane biofilm reactor. *Water Research* 43 no. 1: 173-181.

**APPENDIX A
POINTS OF CONTACT**

Point of Contact	Organization	Phone/Fax/Email	Role in Project
Andrea Leeson	ESTCP 4800 Mark Center Drive Suite 17D08 Alexandria, VA 22350	Phone 571-372-6398 Email Andrea.Leeson@osd.mil	ESTCP Environmental Restoration Program Manager
Patrick Evans	CDM Smith 14432 S.E. Eastgate Way, Suite 100 Bellevue, WA 98007	Phone 425-519-8300 Cell 206-351-0228 Email evanspj@cdmsmith.com	Principal Investigator
Bruce Rittmann	Arizona State University Biodesign Institute 1001 South McAllister Ave. P. O. Box 875801 Tempe, AZ 85287-5801	Phone 480-727-0434 Cell 847-804-2598 Email rittmann@asu.edu	Co-Principal Investigator
Tom Crowley	West Valley Water District 855 West Base Line Road Rialto, CA 92376	Phone 909-875-1804 X702 Cell 909-213-7055 Email tcrowley@wvwd.org	WVWD Site Owner
David Friese	APTwater APTwater 2516 Verne Roberts Circle, Suite H-102 Antioch, CA 94509	Phone 562-661-4999 X612 Cell 925-708-0480 Email dfriese@aptwater.com	Project Manager
Ryan Overstreet	APTwater 2516 Verne Roberts Circle, Suite H-102 Antioch, CA 94509	Phone 562-661-4999 X611 Cell 925-360-7206 Email roverstreet@aptwater.com	Process Engineer
Eva Opitz	CDM Federal Programs 1050 North Reed Station Road, Suite D Carbondale, IL 62902	Phone 618-351-4530 Email opitzem@cdmsmith.com	Program Manager
Jennifer Smith	CDM Smith 14432 S.E. Eastgate Way, Suite 100 Bellevue, WA 98007	Phone 425-519-8300 Email smithjl@cdmsmith.com	Project Engineer
Eugene Leung	California Department of Public Health 850 Marina Bay Parkway Building P, 1st Floor Richmond, CA 94804	Phone 510-620-3460 Email Eugene.Leung@cdph.ca.gov	Regulatory Oversight

Point of Contact	Organization	Phone/Fax/Email	Role in Project
Sean McCarthy	California Department of Public Health 464 W. 4th Street, Room 437. San Bernardino CA 92401	Phone 909-383-4328 Email Sean.McCarthy@cdph.ca.gov	Regulatory Oversight

APPENDIX B
FIELD LOGS

ESTCP: Techn Demonstration Plan
 Perchlorate Destruction Using Membrane Biofilm Reduction
 ESTCP Project Number ER-200541

Date: 4-21-11
 Time: 9AM
 Operator: DAN BEROKOFF

Parameter	Units	Influent	MBFR 1	MBFR 2	Aeration	MBFR Solids Drain	Media Filter Effluent	Finished Water	GAC 1 Effluent	GAC 2 Effluent	IX 1 Effluent	Permitted Outfall
pH												
Temperature	(°C)											
ORP	(mV)											
Pressure	(psi)											
Dissolved Oxygen	(mg/L)											
Nitrate	(mg/L)											
Nitrite	(mg/L)											
Turbidity	(NTU)											
Chlorine Residual	(mg/L)											

MBFR Details:

Target Flow Rate:	(gpm)	

Hypo Tank (gal)

--

Notes: YESTERDAY (4-20) APT + CDM WORKED ON GETTING MBFR + ASSOCIATED SYSTEM HYDRAULICS UP AND RUNNING. AT END OF DAY, THE AERATION TANK + PRODUCT TANK WAS DOSE WITH ~65 PPM OF CHLORINE (1.42gal IN 1300gal). AT 9AM ON (4-21), TOOK CL2 RESIDUALS ON BOTH AERATION + PRODUCT TANKS AND BOTH RECORDED LEVELS OVER 5 mg/L. CALIBRATED PH/ORP METERS AND TURBIDIMETER. DID NOT TAKE SAMPLES TODAY AS THE BAC DISPOSORB UNITS WERE NOT OPERATING PROPERLY - THE PRESSURE WAS BUILDING UP IN THE VESSELS TO THE POINT WHERE IT WAS RESTRICTING FLOW. APT LEFT MBFR ON RECIRC SO IT CAN BEGIN TO INOCULATE. ADDED 1PPM H2PO4 TO EACH REACTOR. WORKING TOWARDS GETTING NEW GAC UNIT IN SYSTEM IN ORDER TO SOLVE PRESSURE BUILD-UP ISSUE.

ESTCP: Tech Demonstration Plan
 Perchlorate Destruction Using Membrane Biofilm Reduction
 ESTCP Project Number ER-200541

Date: 4-22-11
 Time: 8AM
 Operator: DAN BEROKOFF

Parameter	Units	Influent	9AM		Aeration	11AM		Finished Water	GAC 1 Effluent	GAC 2 Effluent	IX 1 Effluent	Permitted Outfall
			MBFR 1	MBFR 2		MBFR 1	MBFR 2					
pH			6.21	5.83		6.24	5.85					
Temperature	(°C)		20.5	19.7		21.2	20.1					
ORP	(mV)		-424	-453		-325	-405					
Pressure	(psi)											
Dissolved Oxygen	(mg/L)	7.0	2.0	0.8								
Nitrate	(mg/L)	8.0	7.5	7.5								
Nitrite	(mg/L)	0	0	0								
Turbidity	(NTU)		0.36	0.48								
Chlorine Residual	(mg/L)											

MBFR Details:		9:20 AM
Target Flow Rate:	(gpm)	
PH R1		5.8
ORP R1	mV	-1150
TEMP R1	°F	75
PH R2		7.8
ORP R2	mV	+196
TEMP R2	°F	66.4
NITRATE ANALYZER		8.08
LAST N FEED		-1.5 ppm N
LAST N R1		0.00
LAST N R2		0.00

Hypo Tank (gal)

Notes:
 MBFR HAD NO ISSUES OPERATING OVER NIGHT. PH METER CHECK: DIPPED INTO BUFFER 4 SOLUTION, READ 4.01. BUFFER 7 SOLUTION, READ 7.00. BUFFER 10 SOLUTION, READ 10.11. ORP METER READ 219mV AGAINST STANDARD SOLUTION. CALIBRATED APT'S PH METERS FOR BOTH MBFR 1 AND 2.

Date: 4-29-11
 Time: 11 AM
 Operator: DANIEL BEROKOFF

LEAD: MBFR 2
 LAG: MBFR 1

Parameter	Units	Influent	MBFR 1	MBFR 2	Aeration	MBFR Solids Drain	Media Filter Effluent	Finished Water	GAC 1 Effluent	GAC 2 Effluent	IX 1 Effluent	Permitted Outfall
pH		7.43	7.65	7.68	7.87							
Temperature	(°C)	19.5	20.9	20.2	20.4							
ORP	(mV)	90	-127	-128	6							
Pressure	(psi)	-	-	-	-							
Dissolved Oxygen	(mg/L)	11	3	3	8.8							
Nitrate	(mg/L)	8	6	7								
Nitrite	(mg/L)	0	0	0								
Turbidity	(NTU)	-	-	-								
Chlorine Residual	(mg/L)											
SULFIDE	(mg/L)											

MBFR Details:	
Target Flow Rate:	(gpm)

Hypo Tank	(gal)
-----------	-------

Notes: SYSTEM RAN OVERNIGHT WITHOUT ANY MISHAPS. TOOK MONTHLY/ANNUAL GRAB SAMPLES TODAY. AFTER TAKING ALL GRAB SAMPLES FOR LAB, APT SHUT OFF H₂ FEED TO SYSTEM FOR ~1.5 HRS IN ORDER TO CALIBRATE LEL SENSORS. MEANING TODAY'S ANALYTICAL FIELD TESTS MAY NOT BE 100% ACCURATE. WAS UNABLE TO PERFORM FIELD TEST ON MULTIMEDIA FILTER DUE TO APT RUNNING BACK WASHES ON BOTH MBFR & FILTER.

Date: 4-25-11
 Time: 10AM
 Operator: DAN BEROKOFF

Parameter	Units	Influent	MBFR 1	MBFR 2	Aeration	MBFR Solids Drain	Media Filter Effluent	Finished Water	GAC 1 Effluent	GAC 2 Effluent	IX 1 Effluent	Permitted Outfall
pH			8.39	8.73								
Temperature	(°C)		23.6	23.5								
ORP	(mV)		-618	-565								
Pressure	(psi)		-	-								
Dissolved Oxygen	(mg/L)		0.35	0.25								
Nitrate	(mg/L)		0	3.2								
Nitrite	(mg/L)		0	2.0								
Turbidity	(NTU)		2.36	3.10								
Chlorine Residual	(mg/L)											

MBFR Details:		11AM
Target Flow Rate:	(gpm)	
PH R1		8.5
ORP R1		-1150
TEMP R1		79.1
PH R2		7.6
ORP R2		604
TEMP R2		73.4
NITRATE ANALYZER		0.91
LAST N FEED		-1.5 ppm N
LAST N R1		0
LAST N R2		0

Hypo Tank	(gal)	
-----------	-------	--

Notes:
WATER LEVEL IN MBFR1 DECREASED BY ROUGHLY 10% OVER THE WEEKEND. ALSO NOTICED THAT 4 MODULES WERE TURNED OFF ON MBFR 2. SPOKE TO RYAN (APT) WHO KNEW ABOUT THAT AND THEN HAD ME TURN THEM BACK ON AROUND 11:20 AM. TOOK DAILY READING PRIOR TO TURNING ON THE 4 REACTORS THAT WERE PREVIOUSLY OFF.

Date: 5-2-11
 Time: 9AM
 Operator: DANIEL BERKOFF

LEAD: MBFR 1
 LAG: MBFR 2

Parameter	Units	Influent	MBFR 1	MBFR 2	Aeration	MBFR Solids Drain	Media Filter Effluent	Finished Water	GAC 1 Effluent	GAC 2 Effluent	IX 1 Effluent	Permitted Outfall
pH		7.55	7.38	6.58	7.13		7.24	7.47				
Temperature	(°C)	18.7	19.7	20.3	20.1		20.4	20.4				
ORP	(mV)	108	-170	-103	20		136	133				
Pressure	(psi)	-	-									
Dissolved Oxygen	(mg/L)	11	0.9	3.0	7.0			7.0				
Nitrate	(mg/L)	8	6	2.4				2.0				
Nitrite	(mg/L)	0	0.6	0				0				
Turbidity	(NTU)	-	-	-	0.99		0.36	0.79				
Chlorine Residual	(mg/L)											
SULFIDE	(mg/L)	0	0	0	0			0				

MBFR Details:	10:00AM
Target Flow Rate:	(gpm)
MBFR 1 PH	7.5
MBFR 2 PH	7.5
NITRATE ANALYZER	0.43
R1 ORP	-243
R2 ORP	-549
R1 Recycle Rate gpm	210
R2 " " gpm	210
FEED RATE gpm	5
R1 Ha Flow ml/min	630
R2 " " " "	690

Phosphate feed rate 2 ml/min
 Hypo Tank (gal) -
 Phosphate tank (gal) 3
 TOTALIZER #gal 38,25,300

Notes:
 SYSTEM APPEARS TO BE STABLE OVER ITS FIRST WEEKEND, (NO MAJOR ISSUES/LEAKS). PH METER READ 4.02, 7.01, 10.11 AGAINST BUFFER SOLUTIONS. ORP READ 218mV AGAINST BUFFER.

ESTCP: Technology Demonstration Plan
 Perchlorate Destruction Using Membrane Biofilm Reduction
 ESTCP Project Number ER-200541

Date: 05/04/11
 Time: 4:30
 Operator: ARUCAN

MBFR 2 LEAD
 MBFR 1 LAG

Parameter	Units	Influent	MBFR 1	MBFR 2	Aeration	MBFR Solids Drain	Media Filter Effluent	Finished Water	GAC 1 Effluent	GAC 2 Effluent	IX 1 Effluent	Permitted Outfall
pH		7.48	6.75	6.58	7.44	-	7.68	7.58				
Temperature	(°C)	19.0	23.5	22.6	22.6	-	23.1	22.4				
ORP	(mV)	100	-210	88	65	-	102	176				
Pressure	(psi)					-						
Dissolved Oxygen	(mg/L)	9	0	0	7	-	5.5	5.5				
Nitrate	(mg/L)	8	0.6	2.4		-		1.2				
Nitrite	(mg/L)	0	0	0		-		0				
Turbidity	(NTU)				4.35	-	1.32	0.75				
Chlorine Residual	(mg/L)					-						
SULFIDE		0	0	0	0			0				

MBFR Details:		
Target Flow Rate:	(gpm)	

Hypo Tank	(gal)	
-----------	-------	--

Notes: on MBFR
 pH meter tested w/ buffer, readings are 4.02, 7.02, 10.07. ORP meter tested, reading is 217.
 Feed pump was shut down due to air in system. Dave w/ APT says NO₃ levels are low and
 not normal. Calibrated turbidity meter, APT WORKED TOWARDS FILLING HYPO TANK AND DETERMINE PUMP
 FLOW RATE BASED ON CONCENTRATION. TOPPED OF PHOSPHATE TANK: 3.8 gal WATER + 42.3 ml
 85% H₃PO₄.

Manual Data Collection												
	Outlet totalizer	Target Flow Rate	Internal Recycle Rate	MBfR 1 pH	MBfR 2 pH	Nitrate Analyzer	Air flow	Air tank Press	Sodium Hypo tank	Phosphate tank	Phosphate Feed Rate	Bag Filter dp
Date	gal	gpm	gpm	SCADA	SCADA	mg-N/L	scfm	psig	gal	gal	(ml/min)	(psi)
4/20/11 18:00	3791700	-	-	-	-	-	-	-	-	-	-	-
4/21/11 9:00	-	-	-	-	-	-	-	-	-	-	-	-
4/22/11 8:00	-	-	-	5.8	7.8	8.08	-	-	-	-	-	-
4/25/11 10:00	-	-	-	8.5	7.6	0.91	-	-	-	-	-	-
4/28/11 18:40	3799700	-	-	-	-	-	-	-	-	5	2	-
4/29/11 11:00	-	5	210	-	-	-	-	-	-	-	2	-
5/2/11 9:00	3825300	5	210	7.5	7.5	0.43	-	-	0	3	2	-
5/4/11 9:30	3837600	5.0	210	6.7	7.5	0.43	1.8	3.6	0	1.8	2	-

ADD MBFR 1 + 2 ORP COLUMNS

Date: 5-6-11
 Time: 9 AM
 Operator: ARUCAN/BEDOKOFF

Lead Reactor: R2

Parameter	Units	Influent	MBFR 1	MBFR 2	Aeration	MBFR Solids Drain	Media Filter Effluent	Finished Water	GAC 1 Effluent	GAC 2 Effluent	IX 1 Effluent	Permitted Outfall
pH		7.42	6.73	6.30	7.91		---	7.14				
Temperature	(°C)	19.2	21.3	18.9	20.5		---	21.4				
ORP	(mV)	120	-205	-200	90		---	120				
Dissolved Oxygen	(mg/L)	9	3.5	0.2	7			5.5				
Nitrate	(mg/L)	0	0	1				0				
Nitrite	(mg/L)	0	0	0.1				0				
Sulfide	(mg/L)	0	0	0	0			0				
Turbidity	(NTU)						---					
Chlorine Residual	(mg/L)											

Manual Site Data:		
Outlet Totalizer:	gal	38474.00
Target Flow Rate:	gpm	5
Internal Recycle Rate:	gpm	210
MBFR 1 pH:	-	6.4
MBFR 2 pH:	-	7.5
MBFR 1 ORP:	mV	-505
MBFR 2 ORP:	mV	-520
Nitrate Analyzer:	mg-N/L	0.43
Air Flow (Aeration):	scfm	1.7
Air Tank Pressure:	psi	2.7
Sodium Hypo Tank:	gal	-
Phosphate Tank:	gal	3.5
Phosphate Feed Rate:	ml/min	2
Bag Filter dp:	psi	
CO2 Cylinder Pressure:	psi	78
H2 Cylinder Pressure:	psi	93

Notes: AERATION TANK HAS SLIGHT SMELL OF SULFUR. MBFR FEED PUMP = 1 GPM DUE TO PROBLEMS WITH AIR. IT IS PLANNED TO RAISE LOW LEVEL SWITCH IN RAW WATER TANK TO ELIMINATE PROBLEM OF AIR/VORTEX. LOW LEVEL SENSOR WAS RAISED 18" IN FEED/RAW WATER TANK. APT INFORMED CDM THAT FEED PUMP LOST PRIME OVER NIGHT. APT HAD SET FLOW TO 1 GPM. 11:00 - FLOW WAS INCREASED TO 10 GPM ON FEED PUMP. LAB SAMPLES ARE TAKEN WHILE PUMP IS FLOWING @ 10 GPM (11:45). CHANGED BAG FILTER.

NITRATE
 INF 4:1
 MBFR 1 2:1
 MBFR 2 2:1
 FINISH 2:1

NITRATE ANALYZER READING
 5720 Hz
 5097 Hz

} TOOK ABOUT 4 MINUTES TO FILL 500 ML BOTTLE FOR SP-100 (MBFR 2)

ESTCP: Technology Demonstration Plan
 Perchlorate Destruction Using Membrane Biofilm Reduction
 ESTCP Project Number ER-200541

Date: 5/9/11
 Time: 10AM
 Operator: DANIEL B.

Lead Reactor: R1

Parameter	Units	Influent	MBFR 1	MBFR 2	Aeration	MBFR Solids Drain	Media Filter Effluent	Finished Water	GAC 1 Effluent	GAC 2 Effluent	IX 1 Effluent	Permitted Outfall
pH		7.28	7.38	6.25	6.86		6.98	6.93				
Temperature	(°C)	17.4	18.9	19.0	18.6		17.8	17.1				
ORP	(mV)	102	-235	-190	-35		85	108				
Dissolved Oxygen	(mg/L)	8	0.7	3	7			7				
Nitrate	(mg/L)	8	0.3	0				0				
Nitrite	(mg/L)	0	0.4	0				0				
Sulfide	(mg/L)	0	0	0	0			0				
Turbidity	(NTU)				2.01		0.76	0.66				
Chlorine Residual	(mg/L)											

Manual Site Data:		
Outlet Totalizer:	gal	386760
Target Flow Rate:	gpm	5
Internal Recycle Rate:	gpm	210
MBFR 1 pH:		7.6
MBFR 2 pH:		7.5
MBFR 1 ORP:	mV	-540
MBFR 2 ORP:	mV	-569
Nitrate Analyzer:	mg-N/L	0.43 5966 Hz
Air Flow (Aeration):	scfm	1.8
Air Tank Pressure:	psi	3.5
Sodium Hypo Tank:	gal	12.5
Phosphate Tank:	gal	1.4
Phosphate Feed Rate:	ml/min	2
Bag Filter dp:	psi	0
CO2 Cylinder Pressure:	psi	
H2 Cylinder Pressure:	psi	700
Last N Feed		8.73 ppm N
Last N (R1)		0.43
Last N (R2)		0.43

Notes: TOPPED OFF PHOSPHATE TANK: ADDED 48.2ML H3PO4 AND 3.6gal H2O.

Date: 5/11/11
 Time: 8:00
 Operator: APUCAN

Lead Reactor: R2

Parameter	Units	Influent	MBR 1	MBR 2	Aeration	MBR Solids Drain	Media Filter Effluent	Finished Water	GAC 1 Effluent	GAC 2 Effluent	IX 1 Effluent	Permitted Outfall
pH		7.47	6.42	6.38	6.85		6.83	7.10				
Temperature	(°C)	18.7	18.8	18.6	19.4		19.5	19.2				
ORP	(mV)	90	-170	-70	-5		50	90				
Dissolved Oxygen	(mg/L)	9	1.5	0	3.5			3.5				
Nitrate	(mg/L)	7	0	1.2				0				
Nitrite	(mg/L)	0	0	0				0				
Sulfide	(mg/L)	0	0	0	0			0				
Turbidity	(NTU)				2.46		1.05	1.31				
Chlorine Residual	(mg/L)							0				

Manual Site Data: 3880500

Outlet Totalizer:	gal	38805
Target Flow Rate:	gpm	210
Internal Recycle Rate:	gpm	
MBIR 1 pH:	-	6.4
MBIR 2 pH:	-	7.5
MBIR 1 ORP:	mV	-492
MBIR 2 ORP:	mV	101
Nitrate Analyzer:	mg-NL	3.33
Air Flow (Aeration):	scfm	1.7
Air Tank Pressure:	psi	3.5
Sodium Hypo Tank:	gal	—
Phosphate Tank:	gal	3.2
Phosphate Feed Rate:	ml/min	2
Bag Filter dp:	psi	
CO2 Cylinder Pressure:	psi	78
H2 Cylinder Pressure:	psi	94
N2 Pressure:		

Notes: DAVID INFORMS CDM THAT FEED PUMP MALFUNCTIONED LAST NIGHT AND WILL BE TROUBLE SHOOTED BY CLYDE TODAY. LAB SAMPLES FOR NITRATE WERE TAKEN FROM ANALYZER FEED AT TOP OF EACH REACTOR. SAMPLES WERE SENT W/ 24 HOUR TAT FOR NITRATE AND PERCHLORATE. CLYDE HAS REMOVED FEED PUMP SUCTION PIPE TO TROUBLE SHOOT PROBLEM

Date: 5/13/11

Time: 9 AM

Operator: DANIEL BEROKOFF

Lead Reactor: R2

18.9 °C

Parameter	Units	Influent	MBIR 1	MBIR 2	Aeration	MBIR Solids Drain	Media Filter Effluent	Finished Water	GAC 1 Effluent	GAC 2 Effluent	IX 1 Effluent	Permitted Outfall
pH		7.31	7.65	7.80	8.01		7.94	7.94				
Temperature	(°C)	20.3	20.3	20.0	20.2		20.4	20.6				
ORP	(mV)	96	-565	-261	-57		143	300				
Dissolved Oxygen	(mg/L)	9	0.02	0.20	7		16	8				
Nitrate	(mg/L)	8.0	0.5	6.25				0.5				
Nitrite	(mg/L)	0	0.3	3.0				0.15				
Sulfide	(mg/L)	0	0	0	0			0				
Turbidity	(NTU)	30.13			1.01		1.09	1.01				
Chlorine Residual	(mg/L)							0.15				

Manual Site Data:		
Outlet Totalizer:	gal	3896800
Target Flow Rate:	gpm	8
Internal Recycle Rate:	gpm	210
MBIR 1 pH:	-	7.5
MBIR 2 pH:	-	7.6
MBIR 1 ORP:	mV	-557
MBIR 2 ORP:	mV	67
Nitrate Analyzer:	mg-N/L	0.10
Air Flow (Aeration):	scfm	1.7
Air Tank Pressure:	psi	3.7
Sodium Hypo Tank:	gal	12.5
Phosphate Tank:	gal	2.3
Phosphate Feed Rate:	ml/min	2
Bag Filter dp:	psi	0
CO2 Cylinder Pressure:	psi	0*
H2 Cylinder Pressure:	psi	700

5966 Hz

Notes:
 PRIME
 APT WAS ON SITE YESTERDAY FIXING PROBLEM IN FEED PUMP. PIPE SHAVING WERE FOUND LODGED IN THE IMPELLOR. INCREASED FEED RATE TO 8gpm. APT INSTALLED NEW SAMPLE LOCATION TAPS FOR SP-100 AND SP-200 TO MITIGATE HIGH D.O. LEVEL READINGS FOR FIELD ANALYSIS KITS. INSPECTED FEED TANK FOR ANY ADDITIONAL PIPE SHAVINGS BUT NOTHING WAS VISIBLE. APT SET UP CHLORINE DOSE PUMP TO BEGIN FEEDING MEDIA FILTER YESTERDAY. MEASURED FLOW RATE ON CL2 PUMP → PUMP SET @ 13 STROKES/MIN AND 25% STROKE LENGTH. THIS YIELDS 2.1 ML/MIN (12.5% SODIUM HYPO).

ADDED 3.7 gal WATER AND 36ml H3PO4 TO PHOSPHATE TANK.

30ml → 14min
 = 2.14 ml/min CL2

LAST FEED SAMPLE: 8.76ppm N
 LAST R1 SAMPLE: 0.07ppm N
 LAST R2 SAMPLE: 6.42ppm N

Date: 5/16/11
 Time: 9:30 AM
 Operator: DANIEL BEROKOFF

Lead Reactor: R1

Parameter	Units	Influent	LEAD MBFR1	LAG MBFR2	Aeration	MBR Solids Drain	Media Filter Effluent	Finished Water	GAC 1 Effluent	GAC 2 Effluent	IX 1 Effluent	Permitted Outfall
pH		7.47	7.38	7.41	7.79		7.79	7.85				
Temperature	(°C)	17.3	18.6	19.0	18.9		18.7	17.7				
ORP	(mV)	452	-370	-552	-117		107	180				
Dissolved Oxygen	(mg/L)	9	0.15	0.05	7		5.5	7				
Nitrate	(mg/L)	8	7	5				3.5				
Nitrite	(mg/L)	0	3	3.5				3.5				
Sulfide	(mg/L)	0	0	0	0			0				
Turbidity	(NTU)	-			0.62	-	0.42	0.48				
Chlorine Residual	(mg/L)											

Manual Site Data:	
Outlet Totalizer:	gal 39,380
Target Flow Rate:	gpm 10
Internal Recycle Rate:	gpm 210
MBFR 1 pH:	- 7.2
MBFR 2 pH:	- 7.2
MBFR 1 ORP:	mV -53
MBFR 2 ORP:	mV -655
Nitrate Analyzer:	mg-N/L 6.15
Nitrate Analyzer Frequency:	Hz 5320
Last N Feed	ppm (N) 8.45
Last N R1	6.14
Last N R2	3.26
Air Flow (Aeration):	scfm 1.7
Air Tank Pressure:	psi 3.6
Sodium Hypo Tank:	gal 12
Phosphate Tank:	gal 3.4
Phosphate Feed Rate:	ml/min 2
Bag Filter dp:	psi 0
CO2 Cylinder Pressure:	psi 0
H2 Cylinder Pressure:	psi 700

Notes: APT INCREASED TARGET FLOW RATE FROM 8 gpm to 10 gpm. CHECKED PH PROBE AGAINST BUFFER SOLUTIONS AND GOT THE FOLLOWING: 7.00, 7.05, 10.14.

Date: 5/18/11
 Time: 9 AM
 Operator: DANIEL BERKOFF

Lead Reactor: R1

Parameter	Units	Influent	MBIR 1	MBIR 2	Aeration	MBIR Solids Drain	Media Filter Effluent	Finished Water	GAC 1 Effluent	GAC 2 Effluent	IX 1 Effluent	Permitted Outfall
pH		7.45	7.39	7.33	7.77		7.77	7.82				
Temperature	(°C)	17.6	18.6	19.0	18.9		18.6	17.7				
ORP	(mV)	80	-280	-530	-80		110	300				
Dissolved Oxygen	(mg/L)	9	0.15	0.10	7		5.5	6				
Nitrate	(mg/L)	8	7	6				6				
Nitrite	(mg/L)	0	3	3.5				3.5				
Sulfide	(mg/L)	0	0	0	0			0				
Turbidity	(NTU)	-			1.16		0.64	0.39				
Chlorine Residual	(mg/L)							0				

Manual Site Data:		
Outlet Totalizer:	gal	396 0400
Target Flow Rate:	gpm	10
Internal Recycle Rate:	gpm	210
MBIR 1 pH:	-	7.2
MBIR 2 pH:	-	7.2
MBIR 1 ORP:	mV	-23
MBIR 2 ORP:	mV	-642
Nitrate Analyzer:	mg-NL	3.68
Nitrate Analyzer Frequency:	Hz	5011
Last N Feed	ppm (N)	8.29
Last N R1		6.31
Last N R2		3.66
Air Flow (Aeration):	scfm	1.6
Air Tank Pressure:	psi	3.6
Sodium Hypo Tank:	gal	11.5
Phosphate Tank:	gal	2.2
Phosphate Feed Rate:	mL/min	2
Bag Filter dp:	psi	0
CO2 Cylinder Pressure:	psi	0
H2 Cylinder Pressure:	psi	700

Notes:
TOPPED OFF PHOSPHATE TANK: ADDED 37.5 mL H₃PO₄ AND 2.8 gal H₂O.
APT HAD ME MEASURE THE FIBER PURGE RATE ON EACH REACTOR THEN DRAIN EACH PURGE LINE...
R1 WAS BUBBLING @ 2 BUBBLES PER SECOND AND R2 WAS PURGING @ 5-8 BUBBLE PER SECOND.
R1 DID NOT HAVE ANY MOISTURE IN ITS LINES. R2 HAD ~0.5 ML WORTH OF MOISTURE THAT
CAME OUT OF ITS LINES. ← DID THIS @ 12:40PM. AT 1:40PM APT HAD ME INCREASE PURGE RATE ON
R1 TO EQUAL THAT OF R2 AS BEST AS POSSIBLE. BOTH PURGING @ ~8 BUBBLES/SECOND.

- NOTES TO TEST AMERICA:
- Needed 5 DOC AMBERS (250ML), ONLY SENT US 3
 - Needed 2 500ML Pkys w/H₂SO₄ for Ammonia but received NONE
 - Need pre-printed COCs + LABELS
 - Need new box of 100 VOA's w/HCl PRESERVATIVE ON ~~5/27/11~~ SINCE MONDAY IS MEMORIAL
 - Also need all weekly bottles on 5/27/11 SINCE MON IS MEMORIAL
 - Need more blank labels

Date: 05/20/11
 Time: 8:30
 Operator: CYDE ARYCAN

Lead Reactor: R2

Parameter	Units	Influent	MBFR 1	MBFR 2	Aeration	MBFR Solids Drain	Media Filter Effluent	Finished Water	GAC 1 Effluent	GAC 2 Effluent	IX 1 Effluent	Permitted Outfall
pH		7.47	7.70	7.74	7.98		7.93	7.85				
Temperature	(°C)	19.0	19.6	19.3	19.5		19.6	19.3				
ORP	(mV)	60	-186	-375	-70		80	100				
Dissolved Oxygen	(mg/L)	9	2.55	2.5	7		7	8				
Nitrate	(mg/L)	8	16.5	17				6.5				
Nitrite	(mg/L)	0	1.75	1.6				1.75				
Sulfide	(mg/L)	0	0	0	0			0				
Turbidity	(NTU)	0.43			0.31		0.35	0.21				
Chlorine Residual	(mg/L)							0				

Manual Site Data:		
Outlet Totalizer:	gal	39872.00
Target Flow Rate:	gpm	10
Internal Recycle Rate:	gpm	210
MBFR 1 pH:	-	7.5
MBFR 2 pH:	-	7.5
MBFR 1 ORP:	mV	-685
MBFR 2 ORP:	mV	-565
Nitrate Analyzer:	mg-N/L	6.95
Nitrate Analyzer Frequency:	Hz	5255
Last N Feed	ppm (N)	6.23
Last N R1		3.44
Last N R2		4.49
Air Flow (Aeration):	scfm	1.6 ^{1/3 FULL}
Air Tank Pressure:	psi	3.6
Sodium Hypo Tank:	gal	5
Phosphate Tank:	gal	2
Phosphate Feed Rate:	ml/min	0
Bag Filter dp:	psi	72
CO2 Cylinder Pressure:	psi	92
H2 Cylinder Pressure:	psi	

Notes: ALL INFLUENT READINGS/SAMPLES TAKEN AFTER PHOSPHATE INJECTION POINT.
 PHOSPHATE TANK IS EMPTIED. NEW SOLUTION WAS MADE w/ FOR FLOW RATE = 10 GPM AND CONC.
 OF 0.52 mg-P/L. APT ON SITE TESTING TEMP. SENSOR SYSTEM SHUT DOWN FROM 10:00 - 11:30.
 APT HAS CALIBRATED PH AND ORP SENSORS FOR R1 AND R2.

ESTCP: Technology Demonstration Plan
 Perchlorate Destruction Using Membrane Biofilm Reduction
 ESTCP Project Number ER-200541

Date: 5-23-11
 Time: 9:30AM
 Operator: DAN BERKOFF

Lead Reactor: R1

Parameter	Units	Influent	LEAD	LAG	Aeration	MBFR Solids Drain	Media Filter Effluent	Finished Water	GAC 1 Effluent	GAC 2 Effluent	IX 1 Effluent	Permitted Outfall
pH		7.58	7.18	7.58	8.00		7.96	7.98				
Temperature	(°C)	18.0	19.0	19.5	19.4		19.3	18.4				
ORP	(mV)	100	-417	-500	-80		140	177				
Dissolved Oxygen	(mg/L)	9	0.15	0.05	7		6	6				
Nitrate	(mg/L)	8	6	3				1.63				
Nitrite	(mg/L)	0	3	3				3				
Sulfide	(mg/L)	0	0	0	0			0				
Turbidity	(NTU)	-			1.04	-	0.30	0.22				
Chlorine Residual	(mg/L)							0				

Manual Site Data:		
Outlet Totalizer:	gal	4021400
Target Flow Rate:	gpm	8
Internal Recycle Rate:	gpm	210
MBFR 1 pH:	-	7.2
MBFR 2 pH:	-	7.2
MBFR 1 ORP:	mV	-239
MBFR 2 ORP:	mV	-690
Nitrate Analyzer:	mg-N/L	5.14
Nitrate Analyzer Frequency:	Hz	5439
Last N Feed:	ppm (N)	8.37
Last N R1:		5.13
Last N R2:		1.49
		4.6
Air Flow (Aeration):	scfm	51.6
Air Tank Pressure:	psi	3.5
Sodium Hypo Tank:	gal	10.5
Phosphate Tank:	gal	5
Phosphate Feed Rate:	ml/min	2
Bag Filter dp:	psi	0
CO2 Cylinder Pressure:	psi	0
H2 Cylinder Pressure:	psi	2200

Notes:
 WHEN PHOSPHATE TANK WAS FILLED LAST WEEK, THE VALVE LEADING TO DOSE PUMP WAS NOT OPENED BACK UP SO NO PHOSPHATE WAS DOSED TO THE SYSTEM ALL WEEKEND. UPON OPENING VALVE AT 10:00AM, H3PO4 WAS SUCCESSFULLY BEING DOSED TO SYSTEM. MBFR INTERNAL RECYCLE FLOW RATE WAS LOWERED ON 5/21/11 TO 8gpm FROM 10gpm DUE TO LACK OF NITRATE REMOVAL (THIS MAY BE DUE TO NO H3PO4). INCREASED STROKE LENGTH ON CL2 PUMP TO 40 AND DECREASED STROKS/MIN TO 80 (FROM 151), DUE TO PUMP LOSING ITS PRIME UPON EACH SITE VISIT - PUMP SHOULD BE OPERATING IN MID TO HIGH RANGE. H2 GENERATOR STOPPED WORKING. ONLY HAD 700lbs REMAINING IN BACKUP 6-PACK SO THAT RAN DRY OVER WEEKEND. SWITCHED HOSE OVER TO ALTERNATE 6 PACK.

ESTCP: Technology Demonstration Plan
 Perchlorate Destruction () Membrane Biofilm Reduction
 ESTCP Project Number ER-200541

Date: 05/25/11
 Time: 9:00
 Operator: APUCAN

Lead Reactor: R1

Parameter	Units	Influent	MBFR 1	MBFR 2	Aeration	MBFR Solids Drain	Media Filter Effluent	Finished Water	GAC 1 Effluent	GAC 2 Effluent	IX 1 Effluent	Permitted Outfall
pH		7.54	7.46	7.52	7.97		7.93	7.92				
Temperature	(°C)	18.9	18.8	20.0	19.9		20.0	19.8				
ORP	(mV)	120	-280	-452	-60		68	320				
Dissolved Oxygen	(mg/L)	9.0	0.15	0.05	5.5		6.0	7.0				
Nitrate	(mg/L)	7	5	2.5				1.75				
Nitrite	(mg/L)	0	1.2	1.5				1.6				
Sulfide	(mg/L)	0	0	0	0			0				
Turbidity	(NTU)	0.59			0.68		0.47	0.51				
Chlorine Residual	(mg/L)							0				

Manual Site Data:		
Outlet Totalizer:	gal	40444
Target Flow Rate:	gpm	8
Internal Recycle Rate:	gpm	210
MBFR 1 pH:		7.2
MBFR 2 pH:		7.2
MBFR 1 ORP:	mV	-103
MBFR 2 ORP:	mV	-590
Nitrate Analyzer:	mg-N/L	—
Nitrate Analyzer Frequency:	Hz	—
Last N Feed	ppm (N)	—
Last N R1		—
Last N R2		—
Air Flow (Aeration):	scfm	1.7
Air Tank Pressure:	psi	3.5
Sodium Hypo Tank:	gal	1/4 Full
Phosphate Tank:	gal	4.5
Phosphate Feed Rate:	ml/min	2
Bag Filter dp:	psi	0
CO2 Cylinder Pressure:	psi	70/250
H2 Cylinder Pressure:	psi	400/1200

Notes: APT ONSITE REPAIRING NITRATE ANALYZER. NO READINGS WERE RECORDED FOR NITRATE AT HMI. DAVID MUSICO AND JOHNATHAN ROBERTS WITH NALCO VISIT SITE FOR CONSULTATION OF FILTER AID. ~~FW~~ THE TREATMENT PROCESS WAS EXPLAINED. NALCO HAS REQUESTED DISCHARGE LIMITS INFORMATION AND WATER QUALITY RESULTS. CH2E WILL DRAFT EMAIL REGARDING VISIT - COLE FROM COM ONSITE PICK-UP ALL TRASH AND DUMP.

Date: 5/27/11

Time: 10AM

Operator: DANIEL BERKOFF

Lead Reactor: R2

Parameter	Units	Influent	MBR1 AERATION 2	LAG	LEAD	MBR Solids Drain	Media Filter Effluent	Finished Water	GAC 1 Effluent	GAC 2 Effluent	IX 1 Effluent	Permitted Outfall
pH		7.53	7.92	7.47	7.58		7.85	7.91				
Temperature	(°C)	19.2	20.7	20.9	20.3		20.9	19.9				
ORP	(mV)	125	-90	-583	-440		100	143				
Dissolved Oxygen	(mg/L)	9	7.05	0.00	0.15		7	7				
Nitrate	(mg/L)	7	6	1.5				2				
Nitrite	(mg/L)	0	3	1.5				2				
Sulfide	(mg/L)	0	0	0	0			0				
Turbidity	(NTU)	-			1.22	-	0.38	0.51				
Chlorine Residual	(mg/L)							0				

Manual Site Data:		
Outlet Totalizer:	gal	4064700
Target Flow Rate:	gpm	8
Internal Recycle Rate:	gpm	210
MBIR 1 pH:	-	7.2
MBIR 2 pH:	-	7.2
MBIR 1 ORP:	mV	-558
MBIR 2 ORP:	mV	-272
Nitrate Analyzer:	mg-N/L	6.22
Nitrate Analyzer Frequency:	Hz	5312
Last N Feed	ppm (N)	8.40
Last N R1		0.07
Last N R2		6.20
Air Flow (Aeration):	scfm	1.6
Air Tank Pressure:	psf	3.6
Sodium Hypo Tank:	gal	9
Phosphate Tank:	gal	4.5
Phosphate Feed Rate:	ml/min	2
Bag Filter dp:	psi	0
CO2 Cylinder Pressure:	psi	0
H2 Cylinder Pressure:	psi	1700

Notes:
 INJECTION VALVE FOR PHOSPHATE LINE WAS CLOSED UPON SITE ARRIVAL. IMMEDIATELY OPENED AND REINSTATED
 FLOW TO MBR. RAN FLOW TEST ON PHOSPHATE DOSING PUMP: (1) 480ml = TIME ZERO (2) 460ml = TIME
 PHOSPHATE PUMP SUCCESSFULLY FLOWING @ 2ml/min. 10 MIN

Date: 6-1-11
 Time: 8:30 AM
 Operator: DANIEL BEROKOFF

Lead Reactor: R1

Parameter	Units	Influent	LEAD TANK	LAG TANK	Aeration	MBR Solids Drain	Media Filter Effluent	Finished Water	GAC 1 Effluent	GAC 2 Effluent	IX 1 Effluent	Permitted Outfall
pH		7.53	7.41	7.56	7.91		7.87	7.93				
Temperature	(°C)	18.0	19.6	20.2	20.1		20.1	19.6				
ORP	(mV)	166	-331	-495	-114		127	229				
Dissolved Oxygen	(mg/L)	9	0.15	0	7		7	7				
Nitrate	(mg/L)	8	7	3.75				3.75				
Nitrite	(mg/L)	0	0.8	3.0				3.0				
Sulfide	(mg/L)	0	0	0	0			0				
Turbidity	(NTU)	0.19			0.81	-	0.39	0.27				
Chlorine Residual	(mg/L)							0				

Manual Site Data:		
Outlet Totalizer:	gal	4120700
Target Flow Rate:	gpm	10
Internal Recycle Rate:	gpm	210
MBIR 1 pH:	-	7.2
MBIR 2 pH:	-	7.2
MBIR 1 ORP:	mV	297 5
MBIR 2 ORP:	mV	-691
Nitrate Analyzer:	mg-N/L	2.24
Nitrate Analyzer Frequency:	Hz	5777
Last N Feed	ppm (N)	8.34
Last N R1		6.30
Last N R2		2.23
Air Flow (Aeration):	scfm	1.6
Air Tank Pressure:	psi	3.6
Sodium Hypo Tank:	gal	7.5
Phosphate Tank:	gal	3.2
Phosphate Feed Rate:	ml/min	2
Bag Filter dp:	psi	0
CO2 Cylinder Pressure:	psi	-
H2 Cylinder Pressure:	psi	1700

Notes:
 CHECKED PH PROBE AGAINST BUFFERS - RESULTS WERE AS FOLLOWS: 4.00, 7.02, 10.17. ORP PROBE READ 218mV AGAINST STD SOLUTIONS. ON 5/31/11 THE PHOSPHATE FEED LINE WAS MOVED TO THE LEAD REACTOR (R1). OPERATOR MADE SURE THAT CHEMICAL WAS BEING FED INTO TANK, HOWEVER SOMETIME OVER THE NIGHT AIR BUILT UP AT A HIGH POINT WHICH PREVENTED ANY PHOSPHATE TO BE DOSED TO SYSTEM. I IMMEDIATELY BLEED OUT AIR BUBBLE AND INCREASED FEED RATE ON PUMP FROM A 25 STROKE LENGTH TO 35. OVER THE SPAN FROM 5/31/11 @ 12PM TO 6/1/11 @ 830AM THERE WAS A TOTAL OF 0.4gal H_3PO_4 SOLUTION ADDED TO SYSTEM. YESTERDAY, OPERATOR ADDED 2.5gal H_2O AND 200mL 95% H_3PO_4 .

GET CLR SPREADSHEET GOING → CALL WHATS CONC. IS BEING DOSED
 IN TANK: DID A 4000:1 DILUTION → YIELDS 3.0ppm = $3.0 \times 4000 = 12,000$ ppm IN TANK
 INCREASED CLR ~~TANK~~ PUMP TO 100STROKE LENGTH AND DECREASED SPM TO 40.

Date: 06/03/11
 Time: 9:00
 Operator: ARUCAN

Lead Reactor: R1

Parameter	Units	Influent	LEAD MBFR 1	CAG MBFR 2	Aeration	MBFR Solids Drain	Media Filter Effluent	Finished Water	GAC 1 Effluent	GAC 2 Effluent	IX 1 Effluent	Permitted Outfall
pH		7.54	7.42	7.55	7.94		7.88	7.89				
Temperature	(°C)	18.8	19.4	20.4	20.0		20.3	20				
ORP	(mV)	220	-460	-570	-80		290	330				
Dissolved Oxygen	(mg/L)	9	0.1	0.05	4.5		7	7.5				
Nitrate	(mg/L)	8.5	5.0	1.5				1.0				
Nitrite	(mg/L)	0	0.75	1.3				1.5				
Sulfide	(mg/L)	0	0	0	0			0				
Turbidity	(NTU)	0.25			0.61		0.53	0.47				
Chlorine Residual	(mg/L)							5				

Manual Site Data:		
Outlet Totalizer:	gal	
Target Flow Rate:	gpm	10
Internal Recycle Rate:	gpm	210
MBFR 1 pH:		7.2
MBFR 2 pH:		7.2
MBFR 1 ORP:	mV	-59
MBFR 2 ORP:	mV	-702
Nitrate Analyzer:	mg-N/L	5.04
Nitrate Analyzer Frequency:	Hz	5450
Last N Feed	ppm (N)	8.31
Last N R1		5.01
Last N R2		0.98
Air Flow (Aeration):	scfm	1.6
Air Tank Pressure:	psi	3.6
Sodium Hypo Tank:	gal	100/18
Phosphate Tank:	gal	1.1
Phosphate Feed Rate:	ml/min	2
Bag Filter dp:	psi	4
CO2 Cylinder Pressure:	psi	300/75
H2 Cylinder Pressure:	psi	1700/92

Notes: CAMERON WELDING STOP BY TO CHECK CHEMICAL SUPPLY. RICHARD W/
 APT WATER IS ONSITE TO REPAIR THE CHLORINE DOSING PUMP, NITRATE FE ANALYZER FEED
 LINE - TAP A NEW PHOSPHATE INJECTION POINT, AND TRY TO TROUBLESHOOT ~~ANY~~
 THE PHOSPHATE FEED PUMP. DANIEL IS ONSITE TO ASSIST APT ON TROUBLESHOOTING THE CHLORINE
 PUMP. HE HAS MIXED NEW BATCH OF CHLORINE SOLUTION. HE WILL CHECK CHLORINE RESIDUAL @ ~~THE~~ DIRECTLY
 DOWNSTREAM OF INJECTION POINT. ADDED 4 GAL 12.5% CL2 AND 12 GAL WATER FROM FILTER EFFLUENT.

CL2 TEST: 4 GAL 12.5% CL2 + 2 GAL 3% CL2 → PUMP SETTING @ 100 STROKE LENGTH + 28 SPM
 + 12 GAL FILTER EFFLUENT
 YIELDS 5 PPM

Date: 6/6/11

Time: 8:30

Operator: ARJUNAN

Lead Reactor: R2

Parameter	Units	Influent	LAST MBFR 1	LEAD MBFR 2	Aeration	MBFR Solids Drain	Media Filter Effluent	Finished Water	GAC 1 Effluent	GAC 2 Effluent	IX 1 Effluent	Permitted Outfall
pH		7.52	7.47	7.54	7.83		7.79	7.93				
Temperature	(°C)	18.7	20.3	18.5	20.3		20.3	19.3				
ORP	(mV)	60	-545	-376	-100		15	250				
Dissolved Oxygen	(mg/L)	10	0	0.15	4.5		5.5	7				
Nitrate	(mg/L)	7	2.2	5.6				2.0				
Nitrite	(mg/L)	0	1.7	1.0				1.74				
Sulfide	(mg/L)	0	0	0	0			0				
Turbidity	(NTU)	0.25			0.72		0.46	0.42				
Chlorine Residual	(mg/L)							0				
MBFR 1												
MBFR 2												
		PURGE										
MBFR 1	ml	83										
MBFR 2	ml	2										

Manual Site Data:		
Outlet Totalizer:	gal	41933.00
Target Flow Rate:	gpm	12
Internal Recycle Rate:	gpm	2.10
MBFR 1 pH:	-	7.2
MBFR 2 pH:	-	7.2
MBFR 1 ORP:	mV	-512
MBFR 2 ORP:	mV	-302
Nitrate Analyzer:	mg-N/L	1.86
Nitrate Analyzer Frequency:	Hz	5810
Last N Feed	ppm (N)	8.33
Last N R1		1.85
Last N R2		6.48
Air Flow (Aeration):	scfm	1.7
Air Tank Pressure:	psi	3.6
Sodium Hypo Tank:	gal	15.5
Phosphate Tank:	gal	4.7
Phosphate Feed Rate:	ml/min	-
Bag Filter dp:	psi	5
CO2 Cylinder Pressure:	psi	85/200
H2 Cylinder Pressure:	psi	90/1700
NITROGEN	PSI	

ADJUST TO BE MADE

8:45 -
 Notes: CLYDE WAS DIRECTED BY APT TO PURGE MBFR 1 & 2 HYDROGEN # LINES AND MEASURE LIQUID THAT IS EXPELLED. ALSO CLYDE WILL MEASURE THE PURGE RATE ON 1/8" TUBE. PHOSPHATE PUMP HAS LOST PRIME OVER WEEKEND. A FLOW TEST WILL BE CONDUCTED ON PHOSPHATE FEED PUMP. APT INSTRUCTED TO OPEN PRODUCT TANK FEED VALVE TO ALLOW 11 GPM FLOW. CLYDE HAS SWITCHED BAG FILTERS ON OUTFALL SYSTEM DUE TO A 5 DP PSI READING. CLYDE HAS SET PHOSPHATE PUMP @ 60 STROKE LENGTH @ 10% STROKES. CHLORINE PUMP SET AT 100 FREQUENCY TO ACHIEVE 1 PPM CL₂ DUE TO NITRITE DEMAND

PHOSPHATE PUMP

(MINS.) TIME	STROKE LENGTH	# OF STROKES	FEED RATE (MEASURED)
5:00	30	25	< 1 ml/min SEEMED TO LOOSE PRIME
2:00	35	25	~ 1 ml/min
2:00	50	25	6 ml/min
2:00	50	20	5 ml/min
2:00	50	10	4 ml/min SEEMED TO LOOSE PRIME
2:00	60	10	~ 2-3 ml/min

NOTE: CHECK @ PRODUCT FOR CL₂ IF > 1 PPM ADJUST.

Date: 6-10-11
 Time: 9:30 AM
 Operator: DAN BEROKOFF

Lead Reactor: R1

Shaded boxes are to remain blank

Parameter	Units	Influent	*Lead Reactor	*Lag Reactor	Aeration	Media Filter Effluent	Finished Water	GAC 1 Effluent	GAC 2 Effluent	IX 1 Effluent	Permitted Outfall
pH		7.53	7.50	7.54	7.85	7.83	7.88				
Temperature	(°C)	18.2	19.5	20.3	20.2	20.2	19.4				
ORP	(mV)	123	-320	-540	-110	80	305				
Dissolved Oxygen	(mg/L)	9	0.15	0	6	6	5.5				
Nitrate	(mg/L)	7.6	6.0	5.0			4.5				
Nitrite	(mg/L)	0	1.5	3.0			2.4				
Sulfide	(mg/L)	0	0	0	0		0				
Turbidity	(NTU)	-			0.60	0.44	0.36				
Chlorine Residual	(mg/L)						0				

* Signifies either MBIR 1 or MBIR 2 depending on which reactor is in the lead or lag position - this changes every 72 hours

Miscellaneous Results:

Parameter	Turbidity (NTU)	Chlorine Residual
MBIR Solids Drain	-	
Filter Backwash	-	
Post Media Filter		3ppm

Notes: CAMERON WELDING FILLED N2 MICRO BULK. BEGAN RECORDING MEMBRANE PURGE RATE TODAY AS APT INSTALLED A ROTAMETER ON 6/8/11. NITRATE ANALYZER WENT DOWN AROUND 9:15 AM AND THEN APT HAD ME PRESS THE RESET BUTTON - FIXED READING AROUND 1:30 PM. ADDED 4 GAL SODIUM HYPO (12.5%) AND 8 GAL MEDIA FILTER EFFLUENT. SET PUMP @ 100% STROKE LENGTH AND 40spm. ADDED 330ML H3PO4 (85%) AND 3.7 GAL FEED WATER TO PHOSPHATE TANK.

DUE TO ME PRESSING WRONG KEY ON ANALYZER

Manual Site Data:		
Outlet Totalizer:	gal	4253100
Target Flow Rate:	gpm	12
Internal Recycle Rate:	gpm	210
MBIR 1 pH:	-	7.2
MBIR 2 pH:	-	7.2
MBIR 1 ORP:	mV	-252
MBIR 2 ORP:	mV	-662
Nitrate Analyzer - R1 Purge rate	mmHg	41
Nitrate Analyzer Frequency: R2	Hz	40
Last N Feed	ppm (N)	7.79
Last N R1		4.84
Last N R2		1.06
Air Flow (Aeration):		7.7
Air Tank Pressure:	scfm	3.6
Sodium Hypo Tank:	psi	6
Phosphate Tank:	gal	1.5
Phosphate Feed Rate:	gal	2.5
Bag Filter dp:	m/min	0
CO2 Cylinder Pressure:	psi	700
H2 Cylinder Pressure:	psi	1400

} millimeters

BACKUP →
 BACKUP →

Date: 6-13-11
 Time: 9:30 AM
 Operator: D. BEROKOFF

Lead Reactor: R2

Shaded boxes are to remain blank

Parameter	Units	Influent	*Lead Reactor	*Lag Reactor	Aeration	Media Filter Effluent	Finished Water	GAC 1 Effluent	GAC 2 Effluent	IX 1 Effluent	Permitted Outfall
pH		7.52	7.53	7.51	7.80	7.73	7.68				
Temperature	(°C)	18.8	19.7	20.5	20.4	20.5	20.2				
ORP	(mV)	585	-335	-570	-90	100	150				
Dissolved Oxygen	(mg/L)	9	0.15	0	6	6	5.5				
Nitrate	(mg/L)	9	8	3.5			3.0				
Nitrite	(mg/L)	0	2.2	2.4			1.7				
Sulfide	(mg/L)	0	0	0	0		0				
Turbidity	(NTU)	0.45			0.86	0.56	0.38				
Chlorine Residual	(mg/L)						0				

* Signifies either MBIR 1 or MBIR 2 depending on which reactor is in the lead or lag position - this changes every 72 hours

Miscellaneous Results:

Parameter	Turbidity (NTU)	Chlorine Residual
MBIR Solids Drain	-	
Filter Backwash	-	
Post Media Filter		2.5

Notes: PHOSPHATE DOSING PUMP WAS LEAKING UPON ARRIVAL (LEAKING FROM SUCTION TUBING). NITRATE ANALYZER WAS OFF UPON ARRIVAL. AERATION COMPRESSOR WAS OFF UPON ARRIVAL. OVER THE WEEKEND THE GFI SWITCHED OFF CAUSING NITRATE ANALYZER AND AERATION COMPRESSOR TO SHUT OFF - AS THEY ARE TIED TO THE SAME RECEPTACLE. RESET GFI AND BOTH AERATION/N2 ANALYZER CAME BACK ON. HAD TO INCREASE SODIUM HYPO PUMP TO 140 spm (FROM 40) JUST TO OBTAIN A 2.5 ppm READING ON POST FILTRATION. ~~APPEARS~~ SODIUM HYPO APPEARS TO BE DEGRADING.

Manual Site Data:		
Outlet Totalizer:	gal	4301300
Target Flow Rate:	gpm	12
Internal Recycle Rate:	gpm	210
MBIR 1 pH:	-	7.2
MBIR 2 pH:	-	7.2
MBIR 1 ORP:	mV	-611
MBIR 2 ORP:	mV	-228
Nitrate Analyzer, RESULTS mg-N/L		39
Nitrite Analyzer, Frequency R2, RESULTS mg-N/L		41
Last N Feed	ppm (N)	7.81
Last N R1		-1.50
Last N R2		-1.50
Air Flow (Aeration):		1.6
Air Tank Pressure:	scfm	3.5
Sodium Hypo Tank:	psi	10
Phosphate Tank:	gal	2.4
Phosphate Feed Rate:	gal	2.5
Bag Filter dp:	mi/min	0
CO2 Cylinder Pressure:	psi	800
H2 Cylinder Pressure:	psi	1400

BACKUP CYLINDERS

DUE TO DISCHARGE COMPRESSION FITTING CONNECTION ON DOSING PUMP - WAS NOT TIGHTENED. LEAK CEASED UPON TIGHTENING FITTING.

Data Log Sheet

ESTCP: Technology Demonstration Plan
 Perchlorate Destruction Using Membrane Biofilm Reduction
 ESTCP Project Number ER-200541

Date: 6-15-11
 Time: 10AM
 Operator: D. BEROKOFF

Lead Reactor: R2

Shaded boxes are to remain blank

SP-100B SP-200A

Parameter	Units	Influent	*Lead Reactor	*Lag Reactor	Aeration	Media Filter Effluent	Finished Water	GAC 1 Effluent	GAC 2 Effluent	IX 1 Effluent	Permitted Outfall
pH											
Temperature	(°C)										
ORP	(mV)										
Dissolved Oxygen	(mg/L)										
Nitrate	(mg/L)										
Nitrite	(mg/L)										
Sulfide	(mg/L)										
Turbidity	(NTU)										
Chlorine Residual	(mg/L)										

* Signifies either MBIR 1 or MBIR 2 depending on which reactor is in the lead or lag position - this changes every 96 hours

Miscellaneous Results:

Parameter	Turbidity (NTU)	Chlorine Residual	Chlorine Residual
MBIR Solids Drain			
Filter Backwash			
Time		<u>10AM</u>	
Pump setting (%/spm)			
Post Media Filter			

PAT EVANS, JEN SMITH VISITED SITE TO GO OVER SYSTEM W/JEN.

Notes: PHOSPHATE SUCTION LINE ACCUMULATED AIR BUBBLES CAUSING SYSTEM NO PHOSPHATE DOSE BEING DOSED TO SYSTEM. VISUALLY INSPECTED TOPS OF REACTORS - FOAM ACCUMULATING IN LAG REACTOR WHICH IS A SIGN OF BIOLOGICAL ACTIVITY. ALSO ON R1 IT WAS OBSERVED THAT THE CENTER MODULE WAS MORE BROWN IN APPEARANCE COMPARED TO THE OUTER MODULES. TOOK WEEKLY PERMIT SAMPLES ON EFFLUENT.

INLET TOTALIZER 534393

Manual Site Data:		
Outlet Totalizer:	gal	<u>4333400</u>
Target Flow Rate:	gpm	<u>12</u>
Internal Recycle Rate:	gpm	<u>210</u>
MBIR 1 pH:		<u>7.2</u>
MBIR 2 pH:		<u>7.2</u>
MBIR 1 ORP:	mV	<u>-611</u>
MBIR 2 ORP:	mV	<u>-188</u>
Nitrate Analyzer <u>R1 SPARGE RATE</u>	mg/L	
MBIR 1 ORP	Hz	
Last N Feed	ppm (N)	<u>8.26</u>
Last N R1		<u>0.79</u>
Last N R2		<u>6.12</u>
Air Flow (Aeration):		<u>1.7</u>
Air Tank Pressure:	scfm	<u>3.8</u>
Sodium Hypo Tank:	psi	<u>0</u>
Phosphate Tank:	gal	<u>3.7</u>
Phosphate Feed Rate:	gal	<u>0*</u>
Bag Filter dp:	ml/min	<u>6*</u>
CO2 Cylinder Pressure:	psi	
H2 Cylinder Pressure:	psi	
INLET PRESSURE	PSI	<u>11.2</u>

464

TAKEN @ 10AM

MILLIMETERS

SEE NOTES

BAG FILTER DP GAUGE READ (PSI) DURING AND AFTER SUMP GOING ON/OFF.

PHOSPHATE PUMP TEST (FLOW): $480\text{ml} - 453\text{ml} = 27\text{ml}$ in 10min = 2.7ml/min @ PUMP SETTING OF $\left\{ \begin{array}{l} 50\% \text{ STROKE LENGTH} \\ 20 \text{ STROKES/MIN} \end{array} \right\}$
 $445\text{ml} - 420\text{ml} = 25\text{ml}$ in 10min = 2.5ml/min @ PUMP SETTING OF $\left\{ \begin{array}{l} 40\% \text{ STROKE LENGTH} \\ 20 \text{ SPM} \end{array} \right\}$
 B-23

400ml - 380 ml = 20ml in 10min @ STROKE % = 30 AND 20SPM

6/16/11

- PHOSPHATE PUMP

TIME ①	TIME ②	PUMP STROKE LENGTH	PUMP SPM	VOLUME DISPLACED	ML/MIN
9:04 AM	9:14 AM	60	20	467.5ml - 434ml	3.35
9:16 AM	10:12 AM	60	20	427ml - 239ml	3.36
10:26 AM	10:55 AM	60	30	466ml - 300	5.72
10:59 AM	11:12 AM	50	30	278ml - 214ml	4.92
11:13 AM	11:31 AM	40	30	459ml - 387ml	4
11:33 AM	11:47 AM	40 30	30	375ml - 326	3.5

→ AT 11:50 AM, PLACED PHOSPHATE PUMP BACK TO 2ml/min (30% STROKE / 20 SPM)

Date: 6-16-11
 Time: 8:30AM
 Operator: D. BERKOFF

Lead Reactor: R1

Shaded boxes are to remain blank

Parameter	Units	Influent	SP-100A	SP-200B	Aeration	Media Filter Effluent	Finished Water	GAC 1 Effluent	GAC 2 Effluent	IX 1 Effluent	Permitted Outfall
			*Lead Reactor	*Lag Reactor							
pH		7.66	7.52	7.53	7.84	7.76	7.87				
Temperature	(°C)	19.0	19.9	20.6	20.6	19.6	20.4				
ORP	(mV)	161	-282	-526	-75	151	65				
Dissolved Oxygen	(mg/L)	9	0.5	0	7	6	6				
Nitrate	(mg/L)	9	8	4			4				
Nitrite	(mg/L)	0	1.5	3			3				
Sulfide	(mg/L)	0	0	0	0		0				
Turbidity	(NTU)	0.97			1.31	0.38	0.77				
Chlorine Residual	(mg/L)										

* Signifies either MBIR 1 or MBIR 2 depending on which reactor is in the lead or lag position - this changes every 72 hours

96

INLET TOTALIZER: 549338

Manual Site Data:		
Outlet Totalizer:	gal	4348200
Target Flow Rate:	gpm	12
Internal Recycle Rate:	gpm	210
MBIR 1 pH:		7.2
MBIR 2 pH:		7.2
MBIR 1 ORP:	mV	-303
MBIR 2 ORP:	mV	-663
Nitrate Analyzer:	-mg/ML	
Nitrate Analyzer Frequency:	-Hz	
Last N Feed	ppm (N)	7.95
Last N R1		5.42
Last N R2		0.69
Air Flow (Aeration):		1.7
Air Tank Pressure:	scfm	3.8
Sodium Hypo Tank:	psi	0
Phosphate Tank:	gal	4.3
Phosphate Feed Rate:	gal	2.0
Bag Filter dp:	m/min	6
CO2 Cylinder Pressure:	psi	800
H2 Cylinder Pressure:	psi	1400

BACKUP {

Miscellaneous Results:

Parameter	Turbidity (NTU)	Chlorine Residual
MBIR Solids Drain	-	
Filter Backwash	-	
Post Media Filter		-

* NOTE: BEGAN SAMPLING FROM SP-100A + SP-200B TODAY PER PAT'S DIRECTION DURING OUR SITE MEETING W/JEN ON 6/15/11.

Notes: CHECKED PH METER AGAINST BUFFERS: MEASURED 4.02, 7.01, 10.11. NOTICED AIR BUBBLE (VERY SMALL) COMING THRU SP-100A TUBING... THIS MAY BE DUE TO WATER BEING AERATED ON ITS WAY TO BEING OVER-FLOWN IN R2. Checked turbidity standards; measured 20.6 NTU, 104 NTU, and 0.0 NTU. DI water read 0.16, <0.1 Std read 0.00

@1250 - collected sample post phosphate feed for o-PO4 analysis called INFLUENT-POST NUTRIENT
 @1515 - collected samples from lead effluent (SP-100A) + lag effluent (SP-200B) called LEAD REACTOR + LAG REACTOR for perchlorate and nitrate/nitrite analysis

@1535 - added 90 mL of H3PO4 + 1 gal of feed water to phosphate tank, final reading = 5 gallons

6/16/11 - SODIUM HYPO PUMP

TIME ①	TIME ②	PUMP STROKE LENGTH %	SPM	VOLUME DISPLACED (ML)	ML/MIN
1:00pm	1:10pm	100	30	476ml - 417ml	5.9 ml
1:12pm	1:22pm	100	20	407ml - 364ml	4.3
1:24pm	1:34pm	100	15	355ml - 322ml	3.3
1:35pm	1:55pm	100	40	458ml - 308	7.5
1:56	2:06pm	100	50	500ml - 394	10.6
2:07	2:24pm	100	55	454 - 253	11.8

6/16/11

2:40pm

	SP-100A	SP-100B	SP-200B
PH	7.49	7.49	7.51
TEMP	20.7	20.6	21.6
ORP	-300	-395	-559
DO	0.4	0.2-0.1	0.2 0
NITRATE	8	8	4
NITRITE	1.7	1.8	3.6

SP-200A not collected (mbfr 1 is in the lead)

Date: 6/20/11
 Time: 1:00PM
 Operator: D. BERDOKOFF Lead Reactor: R2

Shaded boxes are to remain blank

SP-200A SP-100B

Parameter	Units	Influent	*Lead Reactor	*Lag Reactor	Aeration	Media Filter Effluent	Finished Water	GAC 1 Effluent	GAC 2 Effluent	IX 1 Effluent	Permitted Outfall
pH		7.66	7.49	7.47		7.79					
Temperature	(°C)	19.9	22.7	23.0		26.1					
ORP	(mV)	120	425	660							
Dissolved Oxygen	(mg/L)										
Nitrate	(mg/L)										
Nitrite	(mg/L)										
Sulfide	(mg/L)										
Turbidity	(NTU)										
Chlorine Residual	(mg/L)						>5				

* Signifies either MBIR 1 or MBIR 2 depending on which reactor is in the lead or lag position - this changes every 72 hours

Miscellaneous Results:

Parameter	Turbidity (NTU)	Chlorine Residual
MBIR Solids Drain	-	
Filter Backwash	-	
Post Media Filter		>5

SODIUM HYPO PUMP :
 MAKE/MODEL : IWAKI / EW B1041-VCC
 CAPACITY : 0.6 GPH
 MAX PSI : 115

INFLUENT TOTALIZER : 614854

Manual Site Data:		
Outlet Totalizer:	gal	4414200
Target Flow Rate:	gpm	12
Internal Recycle Rate:	gpm	210
MBIR 1 pH:	-	7.2
MBIR 2 pH:	-	7.2
MBIR 1 ORP:	mV	-613
MBIR 2 ORP:	mV	-162
Nitrate Analyzer:	mg-N/L	3.25
Nitrate Analyzer Frequency:	Hz	5710
Last N Feed	ppm (N)	7.81
Last N R1		0.06
Last N R2		4.84
Air Flow (Aeration):		1.8
Air Tank Pressure:	scfm	3.9
Sodium Hypo Tank:	psi	30*
Phosphate Tank:	gal	2.2
Phosphate Feed Rate:	ml/min - gal*	2
Bag Filter dp:	psi ml/min	
CO2 Cylinder Pressure:	psi	1100
H2 Cylinder Pressure:	psi	1500
R1 Purge rate	mm	38
R2 Purge rate	mm	38 42

1:10pm
 2.83 } 1:10pm
 5710 }
 SEE NOTES

Notes: ADDED 10 GAL 12.5% SODIUM HYPO AND 14 GAL FILTER EFFLUENT. ~~MEAS~~ BEGAN DOSING POST MEDIA EFFLUENT ~~AT~~ AT 12:30pm, PUMP SETTING ~~WAS~~ SET TO 100% STROKE LENGTH AND 50SPM FOR AN INJECTION VOLUME OF ~ 10.6 ml/min. AT 2:30pm MEASURED RESIDUAL ON FINISHED WATER, IT READS WELL OVER 5ppm. BEFORE LEAVING SITE I TURNED DOWN METERING PUMP TO 100% AND 30SPM FOR AN INJECTION VOLUME OF ~ 5.9 ml/min. APT HAD ME CONDUCT A NITRATE ANALYZER TEST BETWEEN 1:15pm - 2pm ALL WHILE SHUTTING OFF FEED - THIS WAS DONE PRIOR TO TAKING DAILY DATA - THIS CAUSED ~~THE~~ US TO NOT BE ABLE TO TAKE ANY FURTHER DATA, TOOK WEEKLY SAMPLES ~~AND~~ FOR PERMIT COMPLIANCE. COVERED ~~AND~~ SOD. HYPO TANK W/BLACK BAGS. COVERED ONLINE TURBIDIMETER AND ORP PROBE ~~ASSOCIATED~~ W/BLACK TRASH BAGS. ~~TO~~

NITRATE ANALYZER

TIME	N	Hz
1:18pm	0.10	5965
1:24pm	0.10	5965
1:30pm	0.10	5965
1:35pm	0.10	5965
1:40pm	0.10	5965
1:45pm	0.10	5965
1:50pm	0.10	5965
1:55pm	0.10	5965
2:01pm	0.10	5965

Date: 06/27/11

Time: 7:30

Operator: ARUCAN

Field Samples													
Calibration	pH calibration? <input checked="" type="checkbox"/> Yes <input type="checkbox"/> No Standards: <input checked="" type="checkbox"/> 4 <input checked="" type="checkbox"/> 7 <input type="checkbox"/> 10 Standard Reading: 4: <u>4.07</u> 7: <u>7.05</u> 10: _____			ORP calibration? <input checked="" type="checkbox"/> Yes <input type="checkbox"/> No $T^2=21.9$ Standards: <input type="checkbox"/> 200 mV Standard Reading: 200: <u>210</u>			Turbidity calibration? <input type="checkbox"/> Yes <input checked="" type="checkbox"/> No Standards: <input type="checkbox"/> 0 <input type="checkbox"/> 0.2 <input type="checkbox"/> 0.4 <input type="checkbox"/> 0.6 <input type="checkbox"/> 1.0 Standard Reading: 0: _____ 1: _____						
	Sample Data	Lead Reactor: <input checked="" type="checkbox"/> MfBR1 <input type="checkbox"/> MfBR2		Lead Sample		Lag Sample							
		SP-100A <input checked="" type="checkbox"/>	SP-200A <input type="checkbox"/>										
		SP-100B <input type="checkbox"/>	SP-200B <input checked="" type="checkbox"/>										
Parameter		Units	Influent	*Lead Reactor	*Lag Reactor	Aeration	Media Filter Effluent	Post Sodium Hypo	Finished Water	GAC 1 Effluent	GAC 2 Effluent	IX 1 Effluent	Permitted Outfall
pH		(std units)	7.52	7.71	7.58	7.86	7.81		7.95				
Temperature		(°C)	18.8	20.6	21.5	21.4	21.6		21.5				
ORP		(mV)	415 ²⁰¹	-120	-610	-130	90		255				
Dissolved Oxygen		(mg/L)	9	0.4	0	6.5	7		7				
Nitrate + Nitrite		(mg/L-N)	8.75	6.0	0.4				0				
Nitrite		(mg/L-N)	0	1.7	0				0				
Sulfide	(mg/L)	0	0	0	0			0					
Turbidity	(NTU)	0.43			0.69	0.34		0.38					
Chlorine Residual	(mg/L)						7.5	6.0					

* Signifies MfBR 1 or MfBR 2 depending on if reactor is in the lead or lag position - this changes every 96 hours

Note: shaded boxes are to remain blank

Treatment System Inspection		
Outlet Totalizer	gal	
Target Flow Rate	gpm	12
Internal Recycle Rate	gpm	212
MfBR 1 pH	std units	7.2
MfBR 2 pH	std units	7.2
MfBR 1 ORP	mV	-65
MfBR 2 ORP	mV	-570
Nitrate Frequency	Hz	5966
Last N Feed	ppm (N)	9.10
Last N R1	ppm (N)	5.49
Last N R2	ppm (N)	0.66
MfBR1 Sparge Rate	mm	-
MfBR2 Sparge Rate	mm	-
Phosphate Tank Level	gal	2.1
Phosphate Feed Rate	mL/min	2
Phosphate Pump Settings	spm % stroke	30 20
Aeration Tank Air Flow	scfm	1.7
Air Tank Pressure	psig	4
Target Media Filter Flow Rate	gpm	
Media Filter Inlet Pressure	psig	
Media Filter Outlet Pressure	psig	5
Sodium Hypo Tank Level	gal	15
Sodium Hypo Feed Rate	mL/min	
Sodium Hypo Pump Settings	spm % stroke	30 100
Coagulant Tank Level	gal	-
Coagulant Feed Rate	mL/min	-
Coagulant Pump Settings		-
CO2 Cylinder Pressure	psi	-
H2 Cylinder Pressure	psi	-
N2 Pressure	psi	-
N2 Flow Rate	scfm	-

Post Finished Water System Inspection		
Collect while sump is running		
Bag Filter ΔP	psi	
GAC-1 Pressure	psig	
GAC-2 Pressure	psig	
IX-1 Pressure	psig	

Backwash Record		
Backwash start time: _____		
Backwash duration	min	
Initial Product Tank Level	gal	
Final Product Tank Level	gal	
Time of sample collection:		
Location	Turbidity (NTU)	TSS Collected?
MBfR Solids Drain		<input type="checkbox"/> Yes <input type="checkbox"/> No
Filter Backwash		<input type="checkbox"/> Yes <input type="checkbox"/> No

Inventory	
H3PO4 Stock (gal)	
Sodium Hypo Stock (gal)	
Additional Field Test Kits Needed?	Dissolved Oxygen
	Nitrate + Nitrite
	Nitrite
	Sulfide
	Chlorine
	o-Phosphate

Feed Tank Additions		
Time: _____	H3PO4	Sodium Hypo
Initial Tank Level (gal)	15.21	15
Stock Added 510mL	15	0
Water Used For Dilution	3.0	15
Volume Dilution Added (gal)	3.0	15
Total Volume Added (gal)	6.0	15
Final Tank Level (gal)	5.0	30

7:30 NOTES:
 Cl_2 RESIDUAL @ FILTER EFFLUENT = 7.5. Cl_2 RESIDUAL @ THE PRODUCT = 6.0. FIELD SAMPLES TAKEN @ 8:00. PH & ORP PROBES TESTED AGAINST STANDARDS. INFLUENT ORP WAS RETESTED AND = 201. B-29

NOTES: 9:45 - RECEIVE SHIPMENT OF HYPOCHLORITE. 4 DRUMS OF 15 GALLONS WERE DELIVERED. NITRATE + NITRITE FIELD SAMPLES WERE TAKEN PARALLEL OF DI WATER @ 10.0 ± 0.1 mg/L AS N STANDARD SOLUTIONS. RESULTS ARE SUMMARIZED BELOW.

10:35 - RECEIVE SHIPMENT OF CHEMETRICS PHOSPHATE TEST KIT. P TANK SOLUTION IS DILUTED TO 1:10 x ~~1/3~~ ³ TIMES. THAT SOLUTIONS IS REDUCED TO 1:2. THE RESULT IS RECORDED BELOW. 12:00 TEST AMERICA ONSITE TO ~~THE~~ PICK-UP SAMPLES. CDM CONTACTED APT AND DISCUSSED PHOSPHATE TANK. IT WAS DETERMINED THAT ADDITIONAL H₃PO₄ WAS ADDED ON 06/22 (900ml H₃PO₄ & 4.5 GALS H₂O). A LEAK IS PRESENT BETWEEN GAC VESSELS. IT ONLY OCCURS WHEN SYSTEM IS UNDER PRESSURE. APT HAS INFORMED CDM, THAT HYDROGEN GENERATOR WAS SHUT OFF ON THURSDAY. HYDROGEN CYLINDERS ARE NEED TO BE RE-ORDERED. EACH TURBIDITY METER HAS BEEN CALIBRATED USING THE AMCO STANDARDS.

~~PHOSPHATE. STANDARD SOLUTIONS~~
~~APT STRAWER~~

~~(SOLUTION REDUCED TO 10:1 CONCENTR.)~~

~~(SOLUTION REDUCED TO~~

CANEPON

NITRATE STANDARD:

	NITRATE + NITRITE	NITRITE
DI WATER	0	
10.0 ± 0.1 mg/L NITRATE STANDARD	10 (2)	
250 mg/L NITRATE	0	

← WAS NOT DONE USING STANDARD

NOTE: STANDARD WAS DILUTED TO A 5:1 SOLUTION (NITRATE) TO BE IN RANGE OF CHEMETRICS KIT.

~~PHOSPHATE~~

	NO DILUTION	REDUCTION OF 10:1 AND 1:1		
		3x REDUCTION	4x	5x
PHOSPHATE:	3.5	10.0 ppm		
FEED TANK:	—	> 10 ppm	5	1.5
INFLUENT (STRAWER):	3.5	—	—	—
WBFR 1:	3.5	—	—	—
WBFR 2:	1.5	—	—	—

TURBIDITY: STANDARD TESTS

STANDARD TESTS	HACH READING
0.0	
0.2	
1.0	
5.0	
20.0	

Date: 07/05/11

Time: 7:45

Operator: ADUCAN

269289

Treatment System Inspection

Outlet Totalizer	gal	4664100
Target Flow Rate	gpm	16
Internal Recycle Rate	gpm	210
MBFR 1 pH	std units	7.2
MBFR 2 pH	std units	7.2
MBFR 1 ORP	mV	8
MBFR 2 ORP	mV	-241
Nitrate Frequency	Hz	4202
Last N Feed	ppm (N)	8.13
Last N R1	ppm (N)	6.36
Last N R2	ppm (N)	0.68
MBFR1 Sparge Rate	mm	210
MBFR2 Sparge Rate	mm	210
Phosphate Pump Settings	spr % stroke	30 20
Aeration Tank Air Flow	scfm	1.7
Air Tank Pressure	psig	3.9
Target Media Filter Flow Rate	gpm	5*NOTE 15.0
Media Filter Inlet Pressure	psig	19
Media Filter Outlet Pressure	psig	#17.5
Sodium Hypo Pump Settings	spr % stroke	30 100
Coagulant Tank Level	gal	-
Coagulant Pump Settings		-
CO2 Cylinder Pressure	psi	85
H2 Cylinder Pressure	psi	
N2 Pressure	psi	160
N2 Flow Rate	scfm	

UNSHADE

Field Samples

Calibration		pH calibration? <input type="checkbox"/> Yes <input checked="" type="checkbox"/> No		ORP calibration? <input type="checkbox"/> Yes <input checked="" type="checkbox"/> No		Turbidity calibration? <input type="checkbox"/> Yes <input checked="" type="checkbox"/> No						
Standards: <input type="checkbox"/> 4 <input type="checkbox"/> 7 <input type="checkbox"/> 10		Temp (Deg C): _____		Standards: <input type="checkbox"/> 0 <input type="checkbox"/> 0.2 <input type="checkbox"/> 0.4 <input type="checkbox"/> 0.6 <input type="checkbox"/> 1.0		Standard Reading: 0: _____ 1: _____						
Standard Reading: 4: _____ 7: _____ 10: _____		Standard Reading: 200: _____		Standard Reading: 0: _____ 1: _____								
Lead Reactor: <input checked="" type="checkbox"/> MBR1 <input type="checkbox"/> MBR2		Lag Reactor: <input type="checkbox"/> MBR1 <input type="checkbox"/> MBR2		Sample Collection Time: <u>8:15</u>								
Lead Sample		Lag Sample										
SP-100A <input checked="" type="checkbox"/> SP-200A <input type="checkbox"/>		SP-100B <input type="checkbox"/> SP-200B <input checked="" type="checkbox"/>										
Parameter	Units	Influent	*Lead Reactor	*Lag Reactor	Aeration	Media Filter Effluent	Post Sodium Hypo	Finished Water	GAC 1 Effluent	GAC 2 Effluent	IX 1 Effluent	Permitted Outfall
pH	(std units)	7.52	7.78	7.62	7.87	7.78		7.80				7.69
Temperature	(°C)	18.9	20.2	21.1	21.1	21.3		21.3				20.1
ORP	(mV)	90	-150	-355	40	95		240				
Dissolved Oxygen	(mg/L)	9	0.5	0	3.5	5		6				
Nitrate + Nitrite	(mg/L-N)	8.5	7.5	1.8				1.6				
Nitrite	(mg/L-N)	0	1.6	1.2				1.0				
Sulfide	(mg/L)	0	0	0	0			0				
Turbidity	(NTU)	0.45			0.74	0.6		1.2				
Chlorine Residual	(mg/L)							0	0			

* Signifies MBFR 1 or MBFR 2 depending on if reactor is in the lead or lag position - this changes every 96 hours

Note: shaded boxes are to remain blank

Post Finished Water System Inspection

Collect while sump is running	
Bag Filter ΔP	psi
GAC-1 Pressure	psig
GAC-2 Pressure	psig
IX-1 Pressure	psig

Feed Tank Additions

	H3PO4	Sodium Hypo
Time	8:00	8:05
Initial Tank Level (gal)	2.5	16
Stock Added	900 ml	10
Type of Water Used For Dilution	INFL.	FILT. EFF
Volume Dilution Added (gal)	2.7	8
Total Volume Added (gal)	2.5	14
Final Tank Level (gal)	5.0	30

Note: There are 3785 mL per gallon.

Backwash Record

Backwash start time:		
Backwash duration	min	
Initial Product Tank Level	gal	
Final Product Tank Level	gal	
Time of sample collection:		
Location	Turbidity (NTU)	TSS Collected?
MBFR Solids Drain		<input type="checkbox"/> Yes <input type="checkbox"/> No
Filter Backwash		<input type="checkbox"/> Yes <input type="checkbox"/> No

Inventory

Type	Check	
H3PO4 Stock (gal)	1	
Sodium Hypo Stock (gal)	60	
Additional Field Test Kits Needed?	Dissolved Oxygen	<input checked="" type="checkbox"/>
	Nitrate + Nitrite	<input checked="" type="checkbox"/>
	Nitrite	<input checked="" type="checkbox"/>
	Sulfide	<input checked="" type="checkbox"/>
	Chlorine	<input checked="" type="checkbox"/>
	o-Phosphate	<input checked="" type="checkbox"/>

NOTES:

~~PERFORMED ON FILTER EFFLUENT CONTAINS A LOT OF AMSEA AND MAY EFFECT FUNCTION.~~ Nitrite STANDARD WAS TESTED. SOLUTION REQUIRE A 1:10 DILUTION TO BE PERFORMED 3 TIMES, TO A CONCENTRATION OF 0.25. RESULTS SHOWED 0.25 ON COLORIMETER

NOTES (CONT.): LAB SAMPLES WILL INCLUDE MONTHLY SAMPLES PER LINE ITEM 24. APT INSTRUCTED CDM TO OPEN MEDIA FILTER FLOW VALVE TO INCREASE FLOW FROM 13.0 GPM TO 15 GPM. CDM ALSO RESTARTS H₂ GENERATOR @ 10:30. THE H₂ GEN. HAD SHUT OFF ON MONDAY. CHLORINE AND PHOSPHATE TANKS HAVE BEEN REFILLED. CLYDE HAS ADDED A ADDITIONAL CLAMP ON THE GAC PIPING TO REDUCE A LEAK. AS OF NOW ~~THE~~ NO LEAK IS OCCURRING. CO₂ THE LARGE CO₂ TANK HAS LOW PRESSURE (10 PSI), SYSTEM CURRENTLY RUNNING ON SMALL CYLINDER.

NOTES 07/07

ONSITE TO FILL PHOSPHATE TANK W/ 2.3 GALLONS OF INFLUENT WATER ONLY. CHECK CHLORINE RESIDUAL IN MEDIA FILTER EFFLUENT (2.0PPM) AND IN THE BREAK PRODUCT TANK (< 1.0PPM, BUT DID SHOW FAINT PINK COLOR). ALSO ~~←~~ SWAPPED GASES ON GAC AND IX SYSTEMS. GAC GAUGE RANGES 0 - 60 PSI, AND IX NOW RANGES FROM 0 - 15 PSI.

CLAMPED WELDING

12345 HAUSTHORN

TIM

PICK-UP @ WEST VALLEY
 MONTHLY PERMIT 2/11/08
 LETTER REGIONAL
 BUTCH AYALA SOUTH
 SHANAE * SECRETARY
 FOOTHILL / BASELINE - LEFT
 RIGHT HAND SIDE

866 842-6876
 9405272

Date: 07/11/11

Time: 8:30

Operator: ARUCAN

Field Samples												
Calibration		USED: 10.1, 20, 100, 800 NTU										
pH calibration? <input type="checkbox"/> Yes <input checked="" type="checkbox"/> No		ORP calibration? <input type="checkbox"/> Yes <input checked="" type="checkbox"/> No				Turbidity calibration? <input checked="" type="checkbox"/> Yes <input type="checkbox"/> No						
Standards: <input type="checkbox"/> 4 <input type="checkbox"/> 7 <input type="checkbox"/> 10		Temp (Deg C): _____				Standards: <input type="checkbox"/> 0 <input type="checkbox"/> 0.2 <input type="checkbox"/> 0.4 <input type="checkbox"/> 0.6 <input type="checkbox"/> 1.0						
Standard Reading: 4: _____ 7: _____ 10: _____		Standard Reading: 200: _____				Standard Reading: 0: <u>0.3</u> 1: <u>2.0</u>						
Lead Reactor: <input checked="" type="checkbox"/> MBFR1 <input type="checkbox"/> MBFR2		Lead Sample <input checked="" type="checkbox"/> SP-100A <input type="checkbox"/> SP-100B		Lag Sample <input type="checkbox"/> SP-200A <input checked="" type="checkbox"/> SP-200B		Sample Collection Time: <u>9:00</u>						
Parameter	Units	Influent	*Lead Reactor	*Lag Reactor	Aeration	Media Filter Effluent	Post Sodium Hypo	Finished Water	GAC 1 Effluent	GAC 2 Effluent	IX 1 Effluent	Permitted Outfall
pH	(std units)	7.58	7.62	7.50	7.76	---	---	---	---	---	---	7.64
Temperature	(°C)	19.0	19.8	20.5	20.3	---	---	---	---	---	---	21.8
ORP	(mV)	90	-160	-85	-70	---	---	---	---	---	---	---
Dissolved Oxygen	(mg/L)	9	0.35	0	7	---	---	---	---	---	---	---
Nitrate + Nitrite	(mg/L-N)	8	7.5	0.5	---	---	---	---	---	---	---	---
Nitrite	(mg/L-N)	0	1.1	0.3	---	---	---	---	---	---	---	---
Sulfide	(mg/L)	0	0	0	0	---	---	---	---	---	---	---
Turbidity	(NTU)	0.51	---	---	0.80	---	---	---	---	---	---	---
Chlorine Residual	(mg/L)	---	---	---	---	---	---	---	---	---	---	---

* Signifies MBFR 1 or MBFR 2 depending on if reactor is in the lead or lag position - this changes every 96 hours
 Note: shaded boxes are to remain blank

Collect while sump is running CHANGED		
Bag Filter ΔP	psi	3
GAC-1 Pressure	psig	14
GAC-2 Pressure	psig	14
IX-1 Pressure	psig	3.5

Backwash start time: _____		
Backwash duration	min	_____
Initial Product Tank Level	gal	_____
Final Product Tank Level	gal	_____
Time of sample collection:		
Location	Turbidity (NTU)	TSS Collected?
MBFR Solids Drain		<input type="checkbox"/> Yes <input type="checkbox"/> No
Filter Backwash		<input type="checkbox"/> Yes <input type="checkbox"/> No

Type	Check	
H3PO4 Stock (gal)	0.4	
Sodium Hypo Stock (gal)	50+	
Additional Field Test Kits Needed?	Dissolved Oxygen	↑
	Nitrate + Nitrite	↑
	Nitrite	↑
	Sulfide	↓
	Chlorine	↓
o-Phosphate	↓	

	H3PO4	Sodium Hypo
Time	9:00	OFF
Initial Tank Level (gal)	2.6	---
Stock Added	130	---
Type of Water Used For Dilution	INF	---
Volume Dilution Added (gal)	2.5	---
Total Volume Added (gal)	2.6	---
Final Tank Level (gal)	5.2	---

LEVEL = 28 GALS

Note: There are 3785 mL per gallon.

NOTES: MEDIA
 APT HAS INFORMED COM THAT EFFLUENT FILTERS ARE NOT OPERATING AND WATER FROM AERATION IS BYPASSED TO SUMP. NO SAMPLES WILL BE COLLECTED FOR THE MEDIA FILTERS OR PRODUCT TANK.

Outlet Totalizer	gal	47748
Target Flow Rate	gpm	16
Internal Recycle Rate	gpm	210
MBFR 1 pH	std units	7.2
MBFR 2 pH	std units	7.2
MBFR 1 ORP	mV	153
MBFR 2 ORP	mV	-565
Nitrate Frequency	Hz	4255
Last N Feed	ppm (N)	7.82
Last N R1	ppm (N)	6.09
Last N R2	ppm (N)	0.08
MBFR1 Sparge Rate	mm	210
MBFR2 Sparge Rate	mm	210
Phosphate Pump Settings	spr	30
	% stroke	100
Aeration Tank Air Flow	scfm	1.5
Air Tank Pressure	psig	3.9
Target Media Filter Flow Rate	gpm	BYPASS
Media Filter Inlet Pressure	psig	BYPASS
Media Filter Outlet Pressure	psig	BYPASS
Sodium Hypo Pump Settings	spr	OFF
	% stroke	OFF
Coagulant Tank Level	gal	---
Coagulant Pump Settings		---
CO2 Cylinder Pressure	psi	34
H2 Cylinder Pressure	psi	92
N2 Pressure	psi	169
N2 Flow Rate	scfm	---

NOTES 07/11/11:

CAMERON WELD HAS BEEN NOTIFIED FOR LOW CO₂ SUPPLY.
THEY WILL BE ONSITE TOMORROW MORNING FOR REPLACEMENT.
APT HAS INSTRUCTED CDM TO TAKE PH AND ORP READINGS
AT THE REACTORS OVERFLOW. SAMPLE RESULTS SUMMARIZED
BELOW. CDM CHANGED BAG FILTERS FOR STAGE/IX
SYSTEM.

	PH	ORP	TEMP
R1 OVERFLOW	7.64	-220	20.2
R2 OVERFLOW	7.56	-420	20.4

Date: 7/18/11

Time: 8:00AM

Operator: BEROKOFF

INLET TOTALIZER: 112356 X10

Field Samples													
Calibration	pH calibration? <input type="checkbox"/> Yes <input checked="" type="checkbox"/> No			ORP calibration? <input type="checkbox"/> Yes <input checked="" type="checkbox"/> No			Turbidity calibration? <input type="checkbox"/> Yes <input checked="" type="checkbox"/> No			Standards: <input type="checkbox"/> 0 <input type="checkbox"/> 0.2 <input type="checkbox"/> 0.4 <input type="checkbox"/> 0.6 <input type="checkbox"/> 1.0			
	Standards: <input type="checkbox"/> 4 <input type="checkbox"/> 7 <input type="checkbox"/> 10			Temp (Deg C): _____			Standard Reading: 0: _____ 1: _____			Standard Reading: 0: _____ 1: _____			
Sample Data	Lead Reactor: <input type="checkbox"/> MfBR1 <input type="checkbox"/> MfBR2		Lead Sample Lag Sample		SP-100A <input type="checkbox"/> SP-200A <input type="checkbox"/>		SP-100B <input type="checkbox"/> SP-200B <input type="checkbox"/>		Sample Collection Time: _____				
	Parameter	Units	Influent	*Lead Reactor	*Lag Reactor	Aeration	Media Filter Effluent	Post Sodium Hypo	Finished Water	GAC 1 Effluent	GAC 2 Effluent	IX 1 Effluent	Permitted Outfall
pH	(std units)											7.51	
Temperature	(°C)											21.9	
ORP	(mV)												
Dissolved Oxygen	(mg/L)												
Nitrate + Nitrite	(mg/L-N)												
Nitrite	(mg/L-N)												
Sulfide	(mg/L)												
Turbidity	(NTU)												
Chlorine Residual	(mg/L)												

* Signifies MBfR 1 or MBfR 2 depending on if reactor is in the lead or lag position - this changes every 96 hours

Note: shaded boxes are to remain blank

Post Finished Water System Inspection		
Collect while sump is running		
Bag Filter ΔP	psi	7
GAC-1 Pressure	psig	
GAC-2 Pressure	psig	
IX-1 Pressure	psig	

Feed Tank Additions		
	H3PO4	Sodium Hypo
Time	1:00pm	-
Initial Tank Level (gal)	2.3	-
Stock Added	500ml	-
Type of Water Used For Dilution	INFL	-
Volume Dilution Added (gal)	2.7	-
Total Volume Added (gal)	2.7	-
Final Tank Level (gal)	5.0	28

Note: There are 3785 mL per gallon.

Backwash Record			
Backwash start time: <u>12:00pm</u>			
Backwash duration	min	40	
Initial Product Tank Level	gal	-	
Final Product Tank Level	gal	-	
Time of sample collection: <u>12:05/12:15/12:24/12:34</u>			
Location	Turbidity (NTU)	TSS Collected?	
MBfR Solids Drain	-	<input checked="" type="checkbox"/> Yes <input type="checkbox"/> No	
Filter Backwash	-	<input type="checkbox"/> Yes <input checked="" type="checkbox"/> No	

Inventory		
Type	Check	
H3PO4 Stock (gal)	1.1	
Sodium Hypo Stock (gal)	50+	
Additional Field Test Kits Needed?	Dissolved Oxygen	<input checked="" type="checkbox"/>
	Nitrate + Nitrite	<input checked="" type="checkbox"/>
	Nitrite	<input checked="" type="checkbox"/>
	Sulfide	<input checked="" type="checkbox"/>
	Chlorine	<input checked="" type="checkbox"/>
	o-Phosphate	<input checked="" type="checkbox"/>

NOTES: FLOW RATE READ 10gpm UPON ARRIVAL. APT LOWERED FEED RATE ON 7/17/11 DUE TO HIGH SUMP LEVEL ALARM. BAG FILTER WAS FULL OF SLIMY BIOMASS(?) AND CAUSING PREVENTING ADEQUATE FLOW TO REACH CAUSING SUMP TO BACK UP

Treatment System Inspection		
Outlet Totalizer	gal	4925400
Target Flow Rate	gpm	10
Internal Recycle Rate	gpm	210
MBfR 1 pH	std units	
MBfR 2 pH	std units	
MBfR 1 ORP	mV	
MBfR 2 ORP	mV	
Nitrate Frequency	Hz	
Last N Feed	ppm (N)	
Last N R1	ppm (N)	
Last N R2	ppm (N)	
MBfR1 Sparge Rate	mm	
MBfR2 Sparge Rate	mm	
Phosphate Pump Settings	spm	20
	% stroke	100.30
Aeration Tank Air Flow	scfm	
Air Tank Pressure	psig	
Target Media Filter Flow Rate	gpm	
Media Filter Inlet Pressure	psig	
Media Filter Outlet Pressure	psig	
Sodium Hypo Pump Settings	spm	
	% stroke	
Coagulant Tank Level	gal	
Coagulant Pump Settings		
CO2 Cylinder Pressure	psi	
H2 Cylinder Pressure	psi	
N2 Pressure	psi	
N2 Flow Rate	scfm	

NOTES CONTINUED,...

° CDM CHANGED OUT BAG FILTER AND SET VALVE CONFIGURATION TO RUN IN PARALLEL.

DID NOT TAKE DAILY ^{FIELD} SAMPLING OR WEEKLY LAB SAMPLING. SAMPLED FOR WEEKLY

PERMIT COMPLIANCE IN ADDITION TO VOC'S ON GAC-1 FOR BACKUP DATA. WAS ALSO ABLE TO SUCCESSFULLY SAMPLE MBFR BACKWASH WATER FOR TSS (TOTAL OF 4 COMPOSITE BACKWASH SAMPLES).

TARGET FLOW RATE ~~WAS~~ SET TO 18gpm.

BRIEFLY STOPPED INFLUENT FEED PUMP TO REPAIR/TIGHTEN ^{SLOW} LEAK ON ^{PUMP} DISCHARGE PLUMBING.

PHOSPHATE: Flow = ~~20gpm~~ → 18gpm (FEED READ 20gpm FOR A SHORT TIME DUE TO BACKWASH CYCLE)
ADD 500ml H₃PO₄
2.7gal Feed water

PHOSPHATE READING TAKEN FROM INFLUENT STRAINER (POST INJECTION) = ^① 5ppm } AS PO₄
= ^② 5ppm }

Date: 7/25/11

Time: 8:30

Operator: ARUCIAN

INFL. RATE: 128636

Field Samples

Calibration	pH calibration? <input checked="" type="checkbox"/> Yes <input type="checkbox"/> No		ORP calibration? <input type="checkbox"/> Yes <input checked="" type="checkbox"/> No		Turbidity calibration? <input type="checkbox"/> Yes <input checked="" type="checkbox"/> No									
	Standards: <input checked="" type="checkbox"/> 4 <input checked="" type="checkbox"/> 7 <input checked="" type="checkbox"/> 10		Temp (Deg C): _____		Standards: <input type="checkbox"/> 0 <input type="checkbox"/> 0.2 <input type="checkbox"/> 0.4 <input type="checkbox"/> 0.6 <input type="checkbox"/> 1.0									
Standard Reading: 4: <u>4.01</u> 7: <u>7.08</u> 10: <u>10.02</u>		Standard Reading: 200: _____		Standard Reading: 0: _____ 1: _____										
Lead Reactor: <input type="checkbox"/> MBR1 <input checked="" type="checkbox"/> MBR2		Lead Sample <input type="checkbox"/> SP-100A <input checked="" type="checkbox"/> SP-200A		Lag Sample <input checked="" type="checkbox"/> SP-100B <input type="checkbox"/> SP-200B										
Sample Collection Time: <u>2:00</u>														
Sample Data	Parameter	Units	Influent	*Lead Reactor	*Lag Reactor	Aeration	Media Filter Effluent	Post Sodium Hypo	Finished Water	GAC 1 Effluent	GAC 2 Effluent	IX 1 Effluent	Permitted Outfall	
	pH	(std units)	7.56	7.65	7.67	7.85	7.82		7.80				7.56	
	Temperature	(°C)	20.0	21.7	21.9	21.9	23.1		22.8					24.3
	ORP	(mV)	135	-290	-540	-244	-90		100					
	Dissolved Oxygen	(mg/L)	9	0.35	0	6	7		8					
	Nitrate + Nitrite	(mg/L-N)	8.5	3.0	0.4				0					
	Nitrite	(mg/L-N)	0	0.6	0				0					
	Sulfide	(mg/L)	0	0	0.2	0.4			0					
	Turbidity	(NTU)	0.49			0.60	0.31		2.3					
	Chlorine Residual	(mg/L)							1.25	0.4				

NOTES:

* Signifies MBR1 or MBR2 depending on if reactor is in the lead or lag position - this changes every 96 hours

Note: shaded boxes are to remain blank

Post Finished Water System Inspection		
Collect while sump is running (AFTER CHANGE OUT)		
Bag Filter ΔP	psi	2
GAC-1 Pressure	psig	6
GAC-2 Pressure	psig	4
IX-1 Pressure	psig	2.2

Backwash Record		
Backwash start time: _____		
Backwash duration	min	
Initial Product Tank Level	gal	
Final Product Tank Level	gal	
Time of sample collection: _____		
Location	Turbidity (NTU)	TSS Collected?
MBFR Solids Drain		<input type="checkbox"/> Yes <input type="checkbox"/> No
Filter Backwash		<input type="checkbox"/> Yes <input type="checkbox"/> No

Inventory		
Type	Check	
H3PO4 Stock (gal)	0	
Sodium Hypo Stock (gal)	50+	
Additional Field Test Kits Needed?	Dissolved Oxygen	✓
	Nitrate + Nitrite	✓
	Nitrite	✓
	Sulfide	NEED MORE
	Chlorine	✓
	α-Phosphate	✓

Feed Tank Additions		
	H3PO4	Sodium Hypo
Time	9:00	11:00
Initial Tank Level (gal)	0	14
Stock Added	500ml BND	0
Type of Water Used For Dilution	INFL.	0
Volume Dilution Added (gal)	5.0	0
Total Volume Added (gal)	5.1	0
Final Tank Level (gal)	5.1	14

NOTES:
 CLIDE ONSITE AND OBSERVED 0.0 GPM INFLUENT FLOW
 TO MBFR REACTORS - RECIRC. PUMPS ARE OPERATING
 @ 210 GPM. APT WAS CONTACTED, PHOSPHATE TANK IS
 EMPTY. WHEN FILLING A LEAK WAS DETECTED AT

Treatment System Inspection		
Outlet Totalizer	gal	508660
Target Flow Rate	gpm	20.0
Internal Recycle Rate	gpm	210.0
MBFR 1 pH	std units	7.21
MBFR 2 pH	std units	7.20
MBFR 1 ORP	mV	-387
MBFR 2 ORP	mV	-45
Nitrate Frequency	Hz	*
Last N Feed	ppm (N)	8.07
Last N R1	ppm (N)	0.44
Last N R2	ppm (N)	2.06
MBFR1 Sparge Rate	mm	210
MBFR2 Sparge Rate	mm	210
Phosphate Pump Settings	spm	20-30
	% stroke	
Aeration Tank Air Flow	scfm	1.6
Air Tank Pressure	psig	4.0
Target Media Filter Flow Rate	gpm	15
Media Filter Inlet Pressure	psig	7.6
Media Filter Outlet Pressure	psig	5.6(0) FR
Sodium Hypo Pump Settings	spm	30
	% stroke	100
Coagulant Tank Level	gal	—
Coagulant Pump Settings		—
CO2 Cylinder Pressure	psi	62
H2 Cylinder Pressure	psi	92
N2 Pressure	psi	192
N2 Flow Rate	scfm	

* NEW NO3 ANALYZER, DID NOT LOCATE THER: ON DISPLAY

525
52011 H3704
2.7 GAL/S
5.8
FOR 20 GPM

NOTES CONT.:

CLYDE ON
LINC CALL
FROM
10:00-11:00

THE PUMP SUCTION / TANK CONNECT. CDM WILL REMOVE TUBING AND REINSTALL/REPAIR LEAK. CDM HAS RE-PRIMED AND RESTARTED ~~TUBING~~ PHOSPHATE INJECTION PUMP. APT HAS INSTRUCTED CDM TO HOLD OFF WATER QUALITY UNTIL AFTERNOON TIMEFRAME. CDM TO COORDINATE CHANGE OF PICK-UP TIME. CDM HAS CHANGE BOTH BAG FILTERS (100/50 IN ONE (200/100 IN THE OTHER) AND PLACED THEM BOTH ONLINE IN PARALLEL CONFIGURATION. TEST AMERICA CONFIRMS NEW PICK-UP TIME OF 4:30^{PM} FOR SAMPLES.

11:00 - APT CONFIRMS THAT MBFR REACTORS CHANGE LEAD REACTORS FROM MBFR #1 → MBFR #2. SAMPLES FOR LEAD WILL BE TAKEN FROM SP-100A AND LAG FROM SP-200B. (DISREGARD NOTATION ON FIELD FORM). ~~CDM~~ APT INFORMED CDM THAT SAMPLING SP-100B & SP-200B WILL REQUIRED SHUTTING NO₃ ANALYZER FEED BEFORE OPENING EITHER SP. THIS WILL PREVENT DRAINING THE ANALYZER. APT INFORMED / INSTRUCTED CDM HOW TO REMOVE AIR-POCKETS FROM LINES IF THIS OCCURS. ALSO CHECK NO₃ ANALYZER DISCHARGE AT AERATION TANK FOR STEADY FLOW.

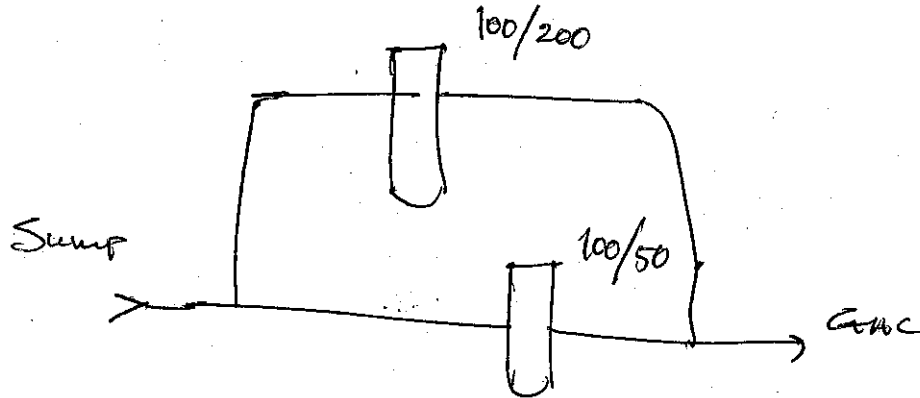

1/2 PSI ^{1 DP} BEFORE CHANGE OUT
2 PSI ^{1 DP} AFTER CHANGE OUT OF FILTER
AND GAUGE

Date: 8/1/11

Time: 9:45

Operator: ARUCAN

Treatment System Inspection

Outlet Totalizer	gal	<u>52772</u>
Target Flow Rate	gpm	<u>220 22</u>
Internal Recycle Rate	gpm	<u>210</u>
MBFR 1 pH	std units	<u>7.2</u>
MBFR 2 pH	std units	<u>7.2</u>
MBFR 1 ORP	mV	<u>-548</u>
MBFR 2 ORP	mV	<u>-544</u>
Nitrate Frequency	Hz	<u>770</u>
Last N Feed	ppm (N)	<u>7.70</u>
Last N R1	ppm (N)	<u>6.21</u>
Last N R2	ppm (N)	<u>1.92</u>
MBFR1 Sparge Rate	mm	<u>210</u>
MBFR2 Sparge Rate	mm	<u>210</u>
Phosphate Pump Settings	spm % stroke	<u>20 30</u>
Aeration Tank Air Flow	scfm	<u>1.6</u>
Air Tank Pressure	psig	<u>3.9</u>
Target Media Filter Flow Rate	gpm	<u>18</u>
Media Filter Inlet Pressure	psig	<u>10.7</u>
Media Filter Outlet Pressure	psig	<u>7.5</u>
Sodium Hypo Pump Settings	spm % stroke	<u>30 100</u>
Coagulant Tank Level	gal	<u>—</u>
Coagulant Pump Settings		<u>—</u>
CO2 Cylinder Pressure	psi	<u>63</u>
H2 Cylinder Pressure	psi	<u>91</u>
N2 Pressure	psi	<u>95</u>
N2 Flow Rate	scfm	

Field Samples

Calibration	pH calibration? <input type="checkbox"/> Yes <input checked="" type="checkbox"/> No		ORP calibration? <input type="checkbox"/> Yes <input checked="" type="checkbox"/> No		Turbidity calibration? <input type="checkbox"/> Yes <input checked="" type="checkbox"/> No								
	Standards: <input type="checkbox"/> 4 <input type="checkbox"/> 7 <input type="checkbox"/> 10		Temp (Deg C): _____		Standards: <input type="checkbox"/> 0 <input type="checkbox"/> 0.2 <input type="checkbox"/> 0.4 <input type="checkbox"/> 0.6 <input type="checkbox"/> 1.0								
Standard Reading: 4: _____ 7: _____ 10: _____		Standard Reading: 200: _____		Standard Reading: 0: _____ 1: _____									
Lead Reactor: <input type="checkbox"/> MfBR1 <input checked="" type="checkbox"/> MfBR2		Lead Sample <input checked="" type="checkbox"/> Lag Sample <input type="checkbox"/>		Sample Collection Time: <u>9:1:30</u>									
		SP-100A <input checked="" type="checkbox"/> SP-200A <input type="checkbox"/>											
		SP-100B <input checked="" type="checkbox"/> SP-200B <input type="checkbox"/>											
Sample Data	Parameter	Units	Influent	*Lead Reactor	*Lag Reactor	Aeration	Media Filter Effluent	Post Sodium Hypo	Finished Water	GAC 1 Effluent	GAC 2 Effluent	IX 1 Effluent	Permitted Outfall
	pH	(std units)	<u>7.60</u>	<u>7.70</u>	<u>7.71</u>	<u>7.88</u>	<u>8.01</u>		<u>8.30</u>				<u>7.79</u>
	Temperature	(°C)	<u>19.0</u>	<u>21.0</u>	<u>21.7</u>	<u>21.7</u>	<u>22.1</u>		<u>21.9</u>				<u>22.4</u>
	ORP	(mV)	<u>-120</u>	<u>-301</u>	<u>-560</u>	<u>-206</u>	<u>-73</u>		<u>90</u>				
	Dissolved Oxygen	(mg/L)	<u>9</u>	<u>0.15</u>	<u>0</u>	<u>5.5</u>	<u>6</u>		<u>6</u>				
	Nitrate + Nitrite	(mg/L-N)	<u>9.5</u>	<u>2.6</u>	<u>0.4</u>				<u>0</u>				
	Nitrite	(mg/L-N)	<u>0</u>	<u>0.8</u>	<u>0</u>				<u>0</u>				
	Sulfide	(mg/L)	<u>0</u>	<u>0</u>	<u>0</u>	<u>0.2</u>			<u>0</u>				
	Turbidity	(NTU)	<u>0.5</u>			<u>0.62</u>	<u>0.51</u>		<u>0.49</u>				
	Chlorine Residual	(mg/L)						<u>0.3</u>	<u>0</u>				

* Signifies MBFR 1 or MBFR 2 depending on if reactor is in the lead or lag position - this changes every 96 hours

Note: shaded boxes are to remain blank

Post Finished Water System Inspection

Collect while sump is running

Bag Filter ΔP	psi	<u>2</u>
GAC-1 Pressure	psig	<u>3 10</u>
GAC-2 Pressure	psig	<u>7</u>
IX-1 Pressure	psig	<u>2.5</u>

Backwash Record

Backwash start time: _____

Backwash duration	min	
Initial Product Tank Level	gal	
Final Product Tank Level	gal	

Time of sample collection: _____

Location	Turbidity (NTU)	TSS Collected?
MBFR Solids Drain		<input type="checkbox"/> Yes <input type="checkbox"/> No
Filter Backwash		<input type="checkbox"/> Yes <input type="checkbox"/> No

Inventory

Type	Check	
H3PO4 Stock (gal)	<input checked="" type="checkbox"/>	
Sodium Hypo Stock (gal)	<input checked="" type="checkbox"/>	
Additional Field Test Kits Needed?	Dissolved Oxygen	<input checked="" type="checkbox"/>
	Nitrate + Nitrite	<input checked="" type="checkbox"/>
	Nitrite	<input checked="" type="checkbox"/>
	Sulfide	<input checked="" type="checkbox"/>
	Chlorine	<input checked="" type="checkbox"/>
o-Phosphate	<input checked="" type="checkbox"/>	

Feed Tank Additions

	H3PO4	Sodium Hypo	
Time	<u>5:00</u>	<u>4:30 4:30</u>	
Initial Tank Level (gal)	<u>0</u>	<u>9.0</u>	
Stock Added	<u>900ml</u>	<u>14 GAL</u>	
Type of Water Used For Dilution	<u>INFL.</u>	<u>M.FILT</u>	
Volume Dilution Added (gal)	<u>5</u>	<u>11 6</u>	<u>GALLON</u>
Total Volume Added (gal)	<u>5.1</u>	<u>20</u>	
Final Tank Level (gal)	<u>5.1</u>	<u>20 29.0</u>	

NOTES:

OBSERVED ICING ON NITROGEN TANK. CAMERON WELDING CONTACTED, THEY WILL BE ONSITE LATER TODAY TO CHECK N TANK AND REPLACE CO2 DEWAR. PHOSPHATE INJECTION TANK WAS FEED LINE

NOTES:

NEEDS TO BE REPLACED, PHOSPHATE NOT INJECTING AT THIS POINT. APT HAS INSTRUCTED CDM TO INCREASE PRESSURE FOR CO₂ FEED BY ADJUSTING REGULATOR. FEED PRESSURE FOR CO₂ IS NOW @ 60-65 PSI. CAMERON WELDING ONSITE TO DROP OF ADDITIONAL CO₂ CYLINDER. DEWAR (CO₂) WILL BE REPLACED TOMORROW. CAMERON WELDING INSTRUCTED CDM TO DE-ICE NITROGEN TANK AND FEED LINE. PRESSURE BUILDER VALVE HAS BEEN OPENED TO INCREASE PRESSURE IN THE NITROGEN. CDM TO CONFIRM IN A FEW HOURS IF PRESSURE HAS GONE UP. CURRENT N TANK PRESSURE = 105. PRESSURE HAS NOT INCREASED AS OF 5:00 AND REMAINS AT 105.

ADDITIONAL SAMPLES:

	SP-100B <i>(from FRONT SIDE OF FIELD FORM)</i>	SP-200B	ph LOOP MBFR 2	PH LOOP MBFR 1
ph	7.71	7.72	7.66	22 7.65
temp	21.7	22.7	20.9	22.3
ORP	-560	-320	-243	-550

Handwritten signature/initials at bottom left of table area.

Date: 8/8/4

Time: 8:30

Operator: ADUCAN

Treatment System Inspection		
Outlet Totalizer	gal	545971
Target Flow Rate	gpm	20
Internal Recycle Rate	gpm	210
MBfR 1 pH	std units	7.2
MBfR 2 pH	std units	7.2
MBfR 1 ORP	mV	-564
MBfR 2 ORP	mV	210
Nitrate Frequency	Hz	
Last N Feed	ppm (N)	7.57
Last N R1	ppm (N)	0.10
Last N R2	ppm (N)	3.62
MBfR1 Sparge Rate	mm	210
MBfR2 Sparge Rate	mm	210
Phosphate Pump Settings	spm % stroke	30 20
Aeration Tank Air Flow	scfm	1.7
Air Tank Pressure	psig	3.9
Target Media Filter Flow Rate	gpm	18
Media Filter Inlet Pressure	psig	10.2
Media Filter Outlet Pressure	psig	7.5
Sodium Hypo Pump Settings	spm % stroke	30 100
Coagulant Tank Level	gal	—
Coagulant Pump Settings		—
CO2 Cylinder Pressure	psi	90
H2 Cylinder Pressure	psi	92
N2 Pressure	psi	169
N2 Flow Rate	scfm	

Field Samples												
Parameter	Units	Influent	Lead Sample	Lag Sample	Aeration	Media Filter Effluent	Post Sodium Hypo	Finished Water	GAC 1 Effluent	GAC 2 Effluent	IX 1 Effluent	Permitted Outfall
			*Lead Reactor	*Lag Reactor								
pH	(std units)	7.57	7.51	7.46	7.68	7.65		7.68				7.60
Temperature	(°C)	18.8	20.1	20.9	20.8	21.0		20.9				20.9
ORP	(mV)	110	-190	-505	-220	10		264				
Dissolved Oxygen	(mg/L)	9	0.9	0	6	6		7				
Nitrate + Nitrite	(mg/L-N)	8.0	3.2	0				0				
Nitrite	(mg/L-N)	0	6.8	0				0				
Sulfide	(mg/L)	0	0	0	0.1			0				
Turbidity	(NTU)	0.290			6.422	0.304		0.147				
Chlorine Residual	(mg/L)							1.0	6.2			

* Signifies MBfR 1 or MBfR 2 depending on if reactor is in the lead or lag position - this changes every 96 hours

Note: shaded boxes are to remain blank

Post Finished Water System Inspection		
Collect while sump is running		
Bag Filter ΔP	psi	2
GAC-1 Pressure	psig	17
GAC-2 Pressure	psig	10
IX-1 Pressure	psig	4

Feed Tank Additions		
	H3PO4	Sodium Hypo
Time	9:30	9:45
Initial Tank Level (gal)	2.8	19
Stock Added	340	0
Type of Water Used For Dilution	INF	0
Volume Dilution Added (gal)	2.2	0
Total Volume Added (gal)	2.2	0
Final Tank Level (gal)	5.0	19

Backwash Record		
Backwash start time:		
Backwash duration	min	
Initial Product Tank Level	gal	
Final Product Tank Level	gal	
Time of sample collection:		
Location	Turbidity (NTU)	TSS Collected?
MBfR Solids Drain		<input type="checkbox"/> Yes <input type="checkbox"/> No
Filter Backwash		<input type="checkbox"/> Yes <input type="checkbox"/> No

Inventory		
Type	Check	
H3PO4 Stock (gal)	1.0	
Sodium Hypo Stock (gal)	45	
Additional Field Test Kits Needed?	Dissolved Oxygen	✓
	Nitrate + Nitrite	✓
	Nitrite	✓
	Sulfide	✓
	Chlorine	✓
	o-Phosphate	1

NEED TO ORDER PHOSPHATE KIT

NOTES:
 CHLORINATOR FEED PUMP HAS MINOR LEAK AT DISCHARGE CONNECTION. IT HAS BEEN REPAIRED. IT WAS NOTICED THAT THE POST FINISH WATER SYSTEM BEHINDS A LARGER DISCHARGE

PRESSURE = 19-20 PSI. A LARGER DP ACROSS THE
IN SYSTEM IS RECORDED. CDM AND APT HAS COORDINATED
A SPARGE AT 12:00 PM. CDM HAS TAKEN
TSS SAMPLES THROUGHOUT THE SPARGE PROCESS.

Date: 8/11/11

Time: 9:30AM

Operator: BEROKOFF

Field Samples													
Calibration	pH calibration? <input type="checkbox"/> Yes <input type="checkbox"/> No			ORP calibration? <input type="checkbox"/> Yes <input type="checkbox"/> No			Turbidity calibration? <input type="checkbox"/> Yes <input type="checkbox"/> No						
	Standards: <input type="checkbox"/> 4 <input type="checkbox"/> 7 <input type="checkbox"/> 10			Temp (Deg C): _____			Standards: <input type="checkbox"/> 0 <input type="checkbox"/> 0.2 <input type="checkbox"/> 0.4 <input type="checkbox"/> 0.6 <input type="checkbox"/> 1.0						
Standard Reading: 4: _____ 7: _____ 10: _____			Standard Reading: 200: _____			Standard Reading: 0: _____ 1: _____							
Sample Data	Lead Reactor: <input type="checkbox"/> MfBR1 <input type="checkbox"/> MfBR2		Lead Sample: SP-200A <input type="checkbox"/> SP-200B <input type="checkbox"/> SP-100A <input type="checkbox"/> SP-100B <input type="checkbox"/>		Lag Sample: _____		Sample Collection Time: _____						
	Parameter	Units	Influent	*Lead Reactor	*Lag Reactor	Aeration	Media Filter Effluent	Post Sodium Hypo	Finished Water	GAC 1 Effluent	GAC 2 Effluent	IX 1 Effluent	Permitted Outfall
	pH	(std units)											
	Temperature	(°C)											
	ORP	(mV)											
	Dissolved Oxygen	(mg/L)											
	Nitrate + Nitrite	(mg/L-N)											
	Nitrite	(mg/L-N)											
	Sulfide	(mg/L)											
	Turbidity	(NTU)											
	Chlorine Residual	(mg/L)											

* Signifies MBfR 1 or MBfR 2 depending on if reactor is in the lead or lag position - this changes every 96 hours

Note: shaded boxes are to remain blank

Treatment System Inspection		
Outlet Totalizer	gal	
Target Flow Rate	gpm	
Internal Recycle Rate	gpm	
MBfR 1 pH	std units	
MBfR 2 pH	std units	
MBfR 1 ORP	mV	
MBfR 2 ORP	mV	
Nitrate Frequency	Hz	
Last N Feed	ppm (N)	
Last N R1	ppm (N)	
Last N R2	ppm (N)	
MBfR1 Sparge Rate	mm	
MBfR2 Sparge Rate	mm	
Phosphate Pump Settings	spm % stroke	
Aeration Tank Air Flow	scfm	
Air Tank Pressure	psig	
Target Media Filter Flow Rate	gpm	
Media Filter Inlet Pressure	psig	
Media Filter Outlet Pressure	psig	
Sodium Hypo Pump Settings	spm % stroke	
Coagulant Tank Level	gal	
Coagulant Pump Settings		
CO2 Cylinder Pressure	psi	
H2 Cylinder Pressure	psi	
N2 Pressure	psi	
N2 Flow Rate	scfm	

Post Finished Water System Inspection		
Collect while sump is running		
Bag Filter ΔP	psi	
GAC-1 Pressure	psig	
GAC-2 Pressure	psig	
IX-1 Pressure	psig	

Backwash Record		
Backwash start time: _____		
Backwash duration	min	
Initial Product Tank Level	gal	
Final Product Tank Level	gal	
Time of sample collection:		
Location	Turbidity (NTU)	TSS Collected?
MBfR Solids Drain		<input type="checkbox"/> Yes <input type="checkbox"/> No
Filter Backwash		<input type="checkbox"/> Yes <input type="checkbox"/> No

Inventory	
Type	Check
H3PO4 Stock (gal)	
Sodium Hypo Stock (gal)	
Additional Field Test Kits Needed?	Dissolved Oxygen
	Nitrate + Nitrite
	Nitrite
	Sulfide
	Chlorine
o-Phosphate	

Feed Tank Additions		
	H3PO4	Sodium Hypo
Time		
Initial Tank Level (gal)		
Stock Added		
Type of Water Used For Dilution		
Volume Dilution Added (gal)		
Total Volume Added (gal)		
Final Tank Level (gal)		

NOTES: CDM ON SITE TO PERFORM CONDUCTIVITY TRACER TEST ON LAG REACTOR (R2). MIXED 14 LBS OF "MORTON'S" SALT WITH 1.7 GAL D.I. WATER IN CARBOY. SALT NEVER DISSOLVED (ALLOWED CARBOY TO SIT IN SUN FOR 3 HOURS WHILE OCCASSIONALLY STIRRING BUT SOLUTION NEVER DISSOLVED. IT WAS DETERMINED THAT SOLUTION WAS AT SATURATION)

TIME	TASK	CONDUCTIVITY ($\mu\text{S}/\text{cm}$)
9:44 AM	BEGAN RECORDING CONDUCTIVITY ON LAG REACTOR (SP-200B)	392
9:54		392
10:05		392
10:14		392

D.I. WATER = $2.25 \mu\text{S}/\text{cm}$

NOTES CONTINUED:

CDM OPTED TO ABANDON EXPERIMENT AND DETERMINE PROPER MIXING CALCULATIONS AND ~~RE~~ ATTEMPT TRACER EXPERIMENT TOMORROW.

Date: 8/15/11

Time: 7:45

Operator: ARUCAN

Field Samples													
Calibration	pH calibration? <input type="checkbox"/> Yes <input checked="" type="checkbox"/> No			ORP calibration? <input type="checkbox"/> Yes <input checked="" type="checkbox"/> No			Turbidity calibration? <input type="checkbox"/> Yes <input checked="" type="checkbox"/> No			Standards: <input type="checkbox"/> 0 <input type="checkbox"/> 0.2 <input type="checkbox"/> 0.4 <input type="checkbox"/> 0.6 <input type="checkbox"/> 1.0			
	Standards: <input type="checkbox"/> 4 <input type="checkbox"/> 7 <input type="checkbox"/> 10			Temp (Deg C): _____			Standard Reading: 200: _____			Standard Reading: 0: _____ 1: _____			
Sample Data	Lead Reactor: <input type="checkbox"/> MBR1 <input checked="" type="checkbox"/> MBR2		Lead Sample: SP-200A <input type="checkbox"/> SP-100A <input checked="" type="checkbox"/>		Lag Sample: SP-200B <input type="checkbox"/> SP-100B <input checked="" type="checkbox"/>		Sample Collection Time: <u>8:30</u>						
	Parameter	Units	Influent	*Lead Reactor	*Lag Reactor	Aeration	Media Filter Effluent	Post Sodium Hypo	Finished Water	GAC 1 Effluent	GAC 2 Effluent	IX 1 Effluent	Permitted Outfall
	pH	(std units)	7.56	7.63	7.70	7.91	7.87		7.89				7.69
	Temperature	(°C)	18.8	19.9	20.7	20.6	20.7		20.8				20.7
	ORP	(mV)	115	-350	-560	-290	-110		230				
	Dissolved Oxygen	(mg/L)	9	0.8	0.25	6	6		7				
	Nitrate + Nitrite	(mg/L-N)	7.5	3.3	0.2				0				
	Nitrite	(mg/L-N)	0	0.6	0				0				
	Sulfide	(mg/L)	0	0	0	0			0				
	Turbidity	(NTU)	—						—				
Chlorine Residual	(mg/L)							1.1	0.3				

Treatment System Inspection		
Outlet Totalizer	gal	<u>5029100</u>
Target Flow Rate	gpm	<u>18</u>
Internal Recycle Rate	gpm	<u>210</u>
MBfR 1 pH	std units	<u>7.2</u>
MBfR 2 pH	std units	<u>7.2</u>
MBfR 1 ORP	mV	<u>-585</u>
MBfR 2 ORP	mV	<u>-46</u>
Nitrate Frequency	Hz	<u>6.61</u>
Last N Feed	ppm (N)	<u>6.61</u>
Last N R1	ppm (N)	<u>0.07</u>
Last N R2	ppm (N)	<u>2.49</u>
MBfR1 Sparge Rate	mm	<u>280</u>
MBfR2 Sparge Rate	mm	<u>280</u>
Phosphate Pump Settings	spm % stroke	<u>20</u> <u>30</u>
Aeration Tank Air Flow	scfm	<u>1.6</u>
Air Tank Pressure	psig	<u>3.9</u>
Target Media Filter Flow Rate	gpm	<u>18</u>
Media Filter Inlet Pressure	psig	<u>11.9</u>
Media Filter Outlet Pressure	psig	<u>7.5</u>
Sodium Hypo Pump Settings	spm % stroke	<u>30</u> <u>100</u>
Coagulant Tank Level	gal	<u>—</u>
Coagulant Pump Settings		<u>—</u>
CO2 Cylinder Pressure	psi	<u>89</u>
H2 Cylinder Pressure	psi	<u>92</u>
N2 Pressure	psi	<u>177</u>
N2 Flow Rate	scfm	<u>—</u>

Post Finished Water System Inspection		
Collect while sump is running		
Bag Filter ΔP	psi	<u>0</u>
GAC-1 Pressure	psig	<u>18</u>
GAC-2 Pressure	psig	<u>14</u>
IX-1 Pressure	psig	<u>0</u>

NOT CORRECT

Backwash Record		
Backwash start time:		
Backwash duration	min	
Initial Product Tank Level	gal	
Final Product Tank Level	gal	
Time of sample collection:		
Location	Turbidity (NTU)	TSS Collected?
MBfR Solids Drain		<input type="checkbox"/> Yes <input type="checkbox"/> No
Filter Backwash		<input type="checkbox"/> Yes <input type="checkbox"/> No

Inventory		
Type	Check	
H3PO4 Stock (gal)		
Sodium Hypo Stock (gal)		
Additional Field Test Kits Needed?	Dissolved Oxygen	
	Nitrate + Nitrite	
	Nitrite	
	Sulfide	
	Chlorine	
o-Phosphate		

Feed Tank Additions		
	H3PO4	Sodium Hypo
Time	<u>8:00</u>	<u>8:30</u>
Initial Tank Level (gal)	<u>2.9</u>	<u>12</u>
Stock Added	<u>250</u>	<u>6</u>
Type of Water Used For Dilution	<u>INFL</u>	<u>FILTER</u>
Volume Dilution Added (gal)	<u>2.1</u>	<u>12</u>
Total Volume Added (gal)	<u>2.1</u>	<u>18</u>
Final Tank Level (gal)	<u>5.0</u>	<u>30</u>

NOTES:
 MAKING SALT SOLUTION CONSISTING OF 1.7 GALL OF WATER AND 4 LBS 11.2 OZ. OF SALT. PLACED OUTSIDE TO INCREASE TEMP OF MIX AND STIRRED VIGOROUSLY.

8/15/11

NOTES CONT.:

CO₂ DEWAR IS EMPTY. COM TO CONTACT CAMERON FOR REPIR. DP GAUGE IS ASSUMED TO BE MALFUNCTIONING DUE TO AIR IN THE TUBING CAUSED BY CYCLING OF THE SUMP PUMP. COM TO INVESTIGATE

BASELINE
 11:00 — 409 $\mu\text{S}/\text{cm}$
 11:15 — 400
 11:30 — 401
 11:45 — 400

DI WATER = 0.11 $\mu\text{S}/\text{cm}$
 SOLUTION = ERROR
 16:1 DILUTION = 45.9 mS/cm

~~Handwritten scribble~~

CONDUCTIVITY TEST TIME	CONDUCTIVITY	NOTES
12:00	2.31 mS/cm	IMMEDIATELY AFTER ADD SOLUTION
12:15	1548 $\mu\text{S}/\text{cm}$	
12:30	3555 1120 $\mu\text{S}/\text{cm}$	
12:45	806 $\mu\text{S}/\text{cm}$	
13:00	595 $\mu\text{S}/\text{cm}$	
13:15	519 $\mu\text{S}/\text{cm}$	
13:30	452 $\mu\text{S}/\text{cm}$	
13:45	429 $\mu\text{S}/\text{cm}$	
14:00	417 $\mu\text{S}/\text{cm}$	
14:15		
14:30		
14:45		
15:00		
15:15		
15:30		
15:45		
16:00		
16:15		
16:30		
16:45		
17:00		
17:15		
17:30		
17:45		
18:00		

Date: 8/17/11

Time: 8:30

Operator: ARUCAN

Field Samples

Calibration	pH calibration? <input type="checkbox"/> Yes <input checked="" type="checkbox"/> No		ORP calibration? <input type="checkbox"/> Yes <input checked="" type="checkbox"/> No		Turbidity calibration? <input type="checkbox"/> Yes <input checked="" type="checkbox"/> No								
	Standards: <input type="checkbox"/> 4 <input type="checkbox"/> 7 <input type="checkbox"/> 10		Temp (Deg C): _____		Standards: <input type="checkbox"/> 0 <input type="checkbox"/> 0.2 <input type="checkbox"/> 0.4 <input type="checkbox"/> 0.6 <input type="checkbox"/> 1.0								
Standard Reading: 4: _____ 7: _____ 10: _____		Standard Reading: 200: _____		Standard Reading: 0: _____ 1: _____									
Lead Reactor: <input type="checkbox"/> MfBR1 <input checked="" type="checkbox"/> MfBR2		Lead Sample: SP-200A <input type="checkbox"/> SP-200B <input type="checkbox"/> SP-100A <input checked="" type="checkbox"/> SP-100B <input checked="" type="checkbox"/>		Lag Sample: _____		Sample Collection Time: <u>8:45</u>							
Sample Data	Parameter	Units	Influent	*Lead Reactor	*Lag Reactor	Aeration	Media Filter Effluent	Post Sodium Hypo	Finished Water	GAC 1 Effluent	GAC 2 Effluent	IX 1 Effluent	Permitted Outfall
	pH	(std units)	7.57	7.62	7.71	7.85	7.84		7.87				7.66
	Temperature	(°C)	19.0	20.7	21.2	21.0	21.2		21.0				21.2
	ORP	(mV)	90	-300	-550	-320	-120		250				
	Dissolved Oxygen	(mg/L)	10	1.5	0.1	6	7		8				
	Nitrate + Nitrite	(mg/L-N)	6.5	3.2	0.3				0.2				
	Nitrite	(mg/L-N)	0	0.5	0				0				
	Sulfide	(mg/L)	0	0	0	0.1			0				
	Turbidity	(NTU)	0.510			0.383	0.264		0.211				
	Chlorine Residual	(mg/L)							1.25	0.9			

* Signifies MBFR 1 or MBFR 2 depending on if reactor is in the lead or lag position - this changes every 96 hours

Note: shaded boxes are to remain blank

Treatment System Inspection

Outlet Totalizer	gal	<u>508000</u>
Target Flow Rate	gpm	<u>18</u>
Internal Recycle Rate	gpm	<u>210</u>
MBfR 1 pH	std units	<u>7.2</u>
MBfR 2 pH	std units	<u>7.2</u>
MBfR 1 ORP	mV	<u>-587</u>
MBfR 2 ORP	mV	<u>-43</u>
Nitrate Frequency	Hz	<u>—</u>
Last N Feed	ppm (N)	<u>3.76</u>
Last N R1	ppm (N)	<u>0.23</u>
Last N R2	ppm (N)	<u>2.92</u>
MBfR1 Sparge Rate	mm	<u>280</u>
MBfR2 Sparge Rate	mm	<u>280</u>
Phosphate Pump Settings	spr % stroke	
Aeration Tank Air Flow	scfm	<u>1.6</u>
Air Tank Pressure	psig	<u>4.0</u>
Target Media Filter Flow Rate	gpm	<u>16</u>
Media Filter Inlet Pressure	psig	<u>11.8</u>
Media Filter Outlet Pressure	psig	<u>6.2</u>
Sodium Hypo Pump Settings	spr % stroke	<u>30</u> <u>100</u>
Coagulant Tank Level	gal	<u>—</u>
Coagulant Pump Settings		<u>—</u>
CO2 Cylinder Pressure	psi	<u>33</u>
H2 Cylinder Pressure	psi	<u>91</u>
N2 Pressure	psi	<u>182</u>
N2 Flow Rate	scfm	

Post Finished Water System Inspection

Collect while sump is running

Bag Filter ΔP	psi	<u>2</u>
GAC-1 Pressure	psig	<u>16</u>
GAC-2 Pressure	psig	<u>12</u>
IX-1 Pressure	psig	<u>6</u>

Backwash Record

Backwash start time: _____

Backwash duration: _____ min

Initial Product Tank Level: _____ gal

Final Product Tank Level: _____ gal

Time of sample collection: _____

Location	Turbidity (NTU)	TSS Collected?
MBfR Solids Drain		<input type="checkbox"/> Yes <input type="checkbox"/> No
Filter Backwash		<input type="checkbox"/> Yes <input type="checkbox"/> No

Inventory

Type	Check	
H3PO4 Stock (gal)	<u>0.6</u>	
Sodium Hypo Stock (gal)	<u>40</u>	
Additional Field Test Kits Needed?	Dissolved Oxygen	<input checked="" type="checkbox"/>
	Nitrate + Nitrite	<input checked="" type="checkbox"/>
	Nitrite	<input checked="" type="checkbox"/>
	Sulfide	<input checked="" type="checkbox"/>
	Chlorine	<u>27</u>
	o-Phosphate	<u>1</u>

Feed Tank Additions

	H3PO4	Sodium Hypo
Time	<u>9:15</u>	<u>9:15</u>
Initial Tank Level (gal)	<u>3.8</u>	<u>27</u>
Stock Added	<u>—</u>	<u>—</u>
Type of Water Used For Dilution	<u>—</u>	<u>—</u>
Volume Dilution Added (gal)	<u>—</u>	<u>—</u>
Total Volume Added (gal)	<u>—</u>	<u>—</u>
Final Tank Level (gal)	<u>3.8</u>	<u>27</u>

NOTES:

10:30 - CAMERON WELDING ONSITE TO REPLACE CO2 DEWAR AND CYLINDER. ON REINSTALL OF DEWAR, THE PRESSURE REGULATOR READ 0 PSI, BUT IT IS FULL. ADJUSTMENT KNOB

ORDERED
 → CONT.

NOTES:

... DOES NOT AFFECT READING - REGULATOR MAY NEED
REPLACEMENT. LEVEL ON TANK READS FULL. CO₂
PRESSURE TO THE SYSTEM IS 88 PSI NOW.

Date: 8/19/11

Time: 9:00AM

Operator: BEROKOFF

Field Samples

Calibration	pH calibration? <input type="checkbox"/> Yes <input checked="" type="checkbox"/> No (<u>OUT OF 3 BUFFERS</u>)		ORP calibration? <input type="checkbox"/> Yes <input checked="" type="checkbox"/> No		Turbidity calibration? <input type="checkbox"/> Yes <input checked="" type="checkbox"/> No							
	Standards: <input type="checkbox"/> 4 <input type="checkbox"/> 7 <input type="checkbox"/> 10		Temp (Deg C): _____		Standards: <input type="checkbox"/> 0 <input type="checkbox"/> 0.2 <input type="checkbox"/> 0.4 <input type="checkbox"/> 0.6 <input type="checkbox"/> 1.0							
Standard Reading: 4: _____ 7: _____ 10: _____		Standard Reading: <u>200</u> <u>720</u>		Standard Reading: 0: _____ 1: _____								
Lead Reactor: <input checked="" type="checkbox"/> MIBR1 <input type="checkbox"/> MIBR2		Lag Reactor: <input type="checkbox"/> SP-200A <input checked="" type="checkbox"/> SP-200B <input type="checkbox"/> SP-100A <input type="checkbox"/> SP-100B		Sample Collection Time: <u>10:00AM</u>								
Parameter	Units	Influent	*Lead Reactor	*Lag Reactor	Aeration	Media Filter Effluent	Post Sodium Hypo	Finished Water	GAC 1 Effluent	GAC 2 Effluent	IX 1 Effluent	Permitted Outfall
pH	(std units)	<u>7.64</u> <u>19.6</u>	7.78	7.44	7.65	7.63		7.70				-
Temperature	(°C)	14.5 <u>20.4</u>	20.4	21.2	21.1	21.4		21.7				-
ORP	(mV)	99	-322	-511	-272	-134		590				
Dissolved Oxygen	(mg/L)	9.0	0.8	0.1	5.5	3.5		4.0				
Nitrate + Nitrite	(mg/L-N)	9.0	4.0	0.6				0.8				
Nitrite	(mg/L-N)	0.0	1.0	0.4				0.0				
Sulfide	(mg/L)	0	0	0.1	0.05			0				
Turbidity	(NTU)	-			0.790	0.320		0.214				
Chlorine Residual	(mg/L)						1.0	0.7				

* Signifies MBfR 1 or MBfR 2 depending on if reactor is in the lead or lag position - this changes every 96 hours

Note: shaded boxes are to remain blank

Treatment System Inspection

Outlet Totalizer	gal	573120C
Target Flow Rate	gpm	18
Internal Recycle Rate	gpm	210
MBfR 1 pH	std units	7.2
MBfR 2 pH	std units	7.2
MBfR 1 ORP	mV	-378
MBfR 2 ORP	mV	-537
Nitrate Frequency	Hz	-
Last N Feed	ppm (N)	2.93
Last N R1	ppm (N)	2.80
Last N R2	ppm (N)	0.31
MBfR1 Sparge Rate	mm	280
MBfR2 Sparge Rate	mm	280
Phosphate Pump Settings	spm	30
	% stroke	30
Aeration Tank Air Flow	scfm	1.6
Air Tank Pressure	psig	3.9
Target Media Filter Flow Rate	gpm	16*
Media Filter Inlet Pressure	psig	13.8
Media Filter Outlet Pressure	psig	6.3
Sodium Hypo Pump Settings	spm	30
	% stroke	100
Coagulant Tank Level	gal	-
Coagulant Pump Settings		-
CO2 Cylinder Pressure	psi	80
H2 Cylinder Pressure	psi	90
N2 Pressure	psi	175
N2 Flow Rate	scfm	-

Post Finished Water System Inspection

Collect while sump is running

Bag Filter ΔP	psi	2
GAC-1 Pressure	psig	110
GAC-2 Pressure	psig	11
IX-1 Pressure	psig	4.2

Backwash Record

Backwash start time: 12:36pm

Backwash duration	min	12
Initial Product Tank Level	gal	
Final Product Tank Level	gal	
Time of sample collection: <u>12:40</u>		
Location	Turbidity (NTU)	TSS Collected?
MBfR Solids Drain	-	<input type="checkbox"/> Yes <input type="checkbox"/> No
Filter Backwash	<u>48</u>	<input checked="" type="checkbox"/> Yes <input type="checkbox"/> No

Inventory

Type	Check	
H3PO4 Stock (gal)	8	
Sodium Hypo Stock (gal)	~40	
Additional Field Test Kits Needed?	Dissolved Oxygen	<input checked="" type="checkbox"/>
	Nitrate + Nitrite	<input checked="" type="checkbox"/>
	Nitrite	<input checked="" type="checkbox"/>
	Sulfide	<input checked="" type="checkbox"/>
	Chlorine	<input checked="" type="checkbox"/>
	o-Phosphate	<input checked="" type="checkbox"/>

NEED TO ORDER PH BUFFERS

Feed Tank Additions

	H3PO4	Sodium Hypo
Time	<u>2:00pm</u>	<u>1:00pm</u>
Initial Tank Level (gal)	<u>0.0</u>	<u>25</u>
Stock Added	<u>520</u>	-
Type of Water Used For Dilution	<u>INF</u>	-
Volume Dilution Added (gal)	<u>3.0</u>	-
Total Volume Added (gal)	<u>3.1</u>	-
Final Tank Level (gal)	<u>5.0</u>	<u>25</u>

NOTES: CALGON ON SITE @ 8:45AM TO PICK UP DISPOSALS AND SPENT GAC/IX (SUPER SACKS). APT ON SITE TO PERFORM MAINTENANCE DUTIES ON SYSTEM. DID NOT REPLACE BAG FILTERS AS CDM WILL AWAIT WORD FROM APT WHEN SUMP FREQUENCIES INCREASE PER OUR CONFERENCE CALL ON MONDAY.

NOTES CONT...

- PERFORMED BACKWASH ON MEDIA FILTER. TOOK COMPOSITE SAMPLE AND SENT IT IN FOR TSS ANALYSIS.

[COMPOSITE TURBIDITY : 48.0 NTU
PURGE TURBIDITY : 0.6 NTU]

- SAMPLED PRODUCT (FINISHED) FOR THRESHOLD ODOR, HAAs, TTHMs. THIS IS FOR WEEK 1 OF OPTIMIZATION ONLY.
- TOOK PHOSPHATE READING @ STRAINER = 2.0 ppm.

Trump, Julee M.

From: Arucan, Clyde
Sent: Monday, August 22, 2011 1:20 PM
To: Evans, Patrick; Berokoff, Daniel; Smith, Jennifer L.
Cc: David Friese; Ryan Overstreet; Renato Vigo
Subject: RE: Overflow photos

All – I am back in the office now and Rich B. is onsite. We decided that he would be able to handle the pump down of the containment area. Here is a summary of my findings.

- Well was in the “AUTO” position (normally in AUTO), but was not operating because the “hi level” alarm indicator was illuminated. I do not know which high level switch is associated with the Well controls? Containment switch or feed tank level switch?
- Containment area was completely full with many pumps and other equipment partially underwater.
- Area around the containment area is saturated due to either overflow or a leak in the containment walls.
- Tank levels are as follows

Tank	Level	Comments
Feed	Full	Engaging all three level switches
Product/Finished	Full	Up to level of overflow to sump, no flow to sump tank was observed
Aeration	90%	Up to level of overflow to sump, no flow to sump tank was observed
Sump	75%	3 of the 4 level switches were engaged. Hi-hi not engaged
Reject	10-25%	
MBfR1	75%	Top 2 feet of modules are exposed
MBfr2	75%	Top 2 feet of modules are exposed
IX/GAC Containment	Empty	

- No major leaks were apparent with system off. Valving and sample ports were in normal positions. The levels in the tanks appeared to be steady.
- A water sample for perchlorate analysis was taken.
- Rich and I had a discussion of pumping the containment area into the Reject tank. We also disussed raising the sump pump so it has time to dry off and operate when the reject tank does get full.

Clyde Arucan

CDM

9220 Cleveland Ave. Suite 100
Rancho Cucamonga, Ca 91730
W: (909) 579-3500
M: (909) 201-1414

From: Evans, Patrick
Sent: Monday, August 22, 2011 10:19 AM
To: Berokoff, Daniel; Smith, Jennifer L.
Cc: David Friese; Ryan Overstreet; Renato Vigo; Arucan, Clyde
Subject: RE: Overflow photos

Thanks Daniel. Let's use either spray paint or some other means of marking the ground to show the extent of the wet soil

From: Berokoff, Daniel

Sent: Monday, August 22, 2011 10:17 AM

To: Evans, Patrick; Smith, Jennifer L.

Cc: David Friese; Ryan Overstreet; Renato Vigo; Arucan, Clyde

Subject: Overflow photos

<< File: photo.jpg >> << File: photo.jpg >> << File: photo.jpg >> << File: photo.jpg >>

Date: 8/26/11

Time: 8:20AM

Operator: BEROKOFF

Field Samples

Calibration	pH calibration? <input type="checkbox"/> Yes <input checked="" type="checkbox"/> No	ORP calibration? <input checked="" type="checkbox"/> Yes <input type="checkbox"/> No	Turbidity calibration? <input type="checkbox"/> Yes <input checked="" type="checkbox"/> No										
	Standards: <input type="checkbox"/> 4 <input type="checkbox"/> 7 <input type="checkbox"/> 10	Temp (Deg C): _____	Standards: <input type="checkbox"/> 0 <input type="checkbox"/> 0.2 <input type="checkbox"/> 0.4 <input type="checkbox"/> 0.6 <input type="checkbox"/> 1.0										
	Standard Reading: 4: _____ 7: _____ 10: _____	Standard Reading: <u>200</u> <u>218</u>	Standard Reading: 0: _____ 1: _____										
Sample Data	Lead Sample <input type="checkbox"/> Lag Sample <input type="checkbox"/>		Sample Collection Time: <u>9:30AM</u>										
	Lead Reactor: <input type="checkbox"/> MIBR1 <input checked="" type="checkbox"/> MIBR2		if MBFR1 in LEAD: SP-200B <input type="checkbox"/> if MBFR2 in LEAD: SP-100A <input type="checkbox"/> SP-100B <input checked="" type="checkbox"/>										
	Parameter	Units	Influent	*Lead Reactor	*Lag Reactor	Aeration	Media Filter Effluent	Post Sodium Hypo	Finished Water	GAC 1 Effluent	GAC 2 Effluent	IX 1 Effluent	Permitted Outfall
	pH	(std units)	7.65	7.47	7.86	7.99	7.92		7.92				7.75
	Temperature	(°C)	19.6	21.6	23.0	22.9	23.5		24.4				24.0
	ORP	(mV)	433	-403	-540	-293	-69		639				
	Dissolved Oxygen	(mg/L)	9.0	0.9	0.15	5.0	2.5		3.0				
	Nitrate + Nitrite	(mg/L-N)	9.0	3.3	0.1				0				
	Nitrite	(mg/L-N)	0	0.75	0				0				
	Sulfide	(mg/L)	0	0.0	0.4	0.2			0				
	Turbidity	(NTU)	0.150			1.30	0.30		0.375				
	Chlorine Residual	(mg/L)						1.0	0.2 2.0				

* Signifies MBFR 1 or MBFR 2 depending on if reactor is in the lead or lag position - this changes every 96 hours

Note: shaded boxes are to remain blank

Treatment System Inspection

Outlet Totalizer	gal	58/2300
Target Flow Rate	gpm	15
Internal Recycle Rate	gpm	280
MBFR 1 pH	std units	7.2
MBFR 2 pH	std units	7.2
MBFR 1 ORP	mV	-340
MBFR 2 ORP	mV	-91
Nitrate Frequency	Hz	-
Last N Feed	ppm (N)	3.08
Last N R1	ppm (N)	0.13
Last N R2	ppm (N)	2.17
MBFR1 Sparge Rate	mm	280
MBFR2 Sparge Rate	mm	280
Phosphate Pump Settings	spm	30
	% stroke	30
Phosphate Concentration at Strainer	mg/LPO4	2.5
Aeration Tank Air Flow	scfm	0.5
Air Tank Pressure	psig	5.3
Target Media Filter Flow Rate	gpm	14
Media Filter Inlet Pressure	psig	9.0
Media Filter Outlet Pressure	psig	5.0
Sodium Hypo Pump Settings	spm	30
	% stroke	100
Coagulant Tank Level	gal	-
Coagulant Pump Settings		-
CO2 Cylinder Pressure	psi	82
H2 Cylinder Pressure	psi	90
N2 Pressure	psi	172
N2 Flow Rate	scfm	-

Post Finished Water System Inspection		
Collect while sump is running		
Bag Filter ΔP	psi	4
GAC-1 Pressure	psig	18
GAC-2 Pressure	psig	14
IX-1 Pressure	psig	3.2

Feed Tank Additions		
	H3PO4	Sodium Hypo
Time	8:30AM	2:00PM
Initial Tank Level (gal)	3.9	16
Stock Added	-	-
Type of Water Used For Dilution	-	-
Volume Dilution Added (gal)	-	-
Total Volume Added (gal)	-	-
Final Tank Level (gal)	3.9	16

Backwash Record		
Backwash start time: _____		
Backwash duration	min	
Initial Product Tank Level	gal	
Final Product Tank Level	gal	
Time of sample collection: _____		
Location	Turbidity (NTU)	TSS Collected?
MBFR Solids Drain	-	<input type="checkbox"/> Yes <input type="checkbox"/> No
Filter Backwash	-	<input type="checkbox"/> Yes <input type="checkbox"/> No

Inventory		
Type	Check	
H3PO4 Stock (gal)	8	
Sodium Hypo Stock (gal)	~40	
Additional Field Test Kits Needed?	Dissolved Oxygen	<input checked="" type="checkbox"/>
	Nitrate + Nitrite	<input checked="" type="checkbox"/>
	Nitrite	<input checked="" type="checkbox"/>
	Summe	<input checked="" type="checkbox"/>
	Chlorine	<input checked="" type="checkbox"/>
	o-Phosphate	<input checked="" type="checkbox"/>

WEEKLY/MONTHLY PERMIT
 NOTES: TOOK SAMPLES FOR ~~WEEKLY~~ COMPLIANCE. RICH W/AFI ON SITE TODAY TO CLEAN UP REMAINING LOOSE ENDS FROM EARLIER IN WEEK. IT WAS NOTICED THAT THE AERATION COMPRESSOR WAS NOT PUSHING THROUGH AS MUCH AIR (SCFM) AS WAS TYPICALLY SEEN HISTORICALLY.

2

NOTES CONT...

CDM NOTIFIED APT (RICH) WHO INDICATED THAT THE COMPRESSOR WAS INDEED UNDER WATER DURING THE OVERFLOW INCIDENT. ~~APT WILL DISCUSS ANALYSIS THEMSELVES AND DETERMINE A SOLUTION~~ LOWER D.O. VALUES WERE SEEN ACROSS THE MEDIA FILTER AND ~~PRODUCT TANK~~ FINISHED WATERS. HIGHER PSI VALUE INDICATED THE LINE MIGHT BE CLOGGED; APT TOOK APART FEED TUBING AND DISCOVERED BLOCKAGE - THERE WAS A SOLID THAT GOT CAUGHT IN THE LINE. COMPRESSOR READINGS ARE BACK TO 201 PSE AND 3.1 SCFM.

TURBIDITY WAS HIGHER ON ~~PRODUCT~~ FINISHED WATER COMPARED TO FILTER EFF. TOOK DUPLICATE FINISHED SAMPLE AND TURBIDITY RESULTS MATCHED.

IT WAS NOTICED THAT H3P04 TANK LEVEL DID NOT LOWER IN VOLUME SINCE THE AM, ~~SURE ENOUGH~~ THE PUMP WAS OFF. THE RESET BUTTON ON THE GFCI OUTLET WAS NOT ACTUATED. UPON RESETTING THE OUTLET, ~~PUMP STARTED~~ PRIMED PUMP AND VERIFIED FLOW.
PUMP STARTED

Date: 8/31/11

Time: 8:30

Field Samples

pH calibration? <input type="checkbox"/> Yes <input checked="" type="checkbox"/> No		ORP calibration? <input type="checkbox"/> Yes <input checked="" type="checkbox"/> No		Turbidity calibration? <input type="checkbox"/> Yes <input checked="" type="checkbox"/> No								
Standards: <input type="checkbox"/> 4 <input type="checkbox"/> 7 <input type="checkbox"/> 10		Temp (Deg C): _____		Standards: <input type="checkbox"/> 0 <input type="checkbox"/> 0.2 <input type="checkbox"/> 0.4 <input type="checkbox"/> 0.6 <input type="checkbox"/> 1.0								
Standard Reading: 4: _____ 7: _____ 10: _____		Standard Reading: 200: _____		Standard Reading: 0: _____ 1: _____								
Lead Reactor: <input type="checkbox"/> MBR1 <input checked="" type="checkbox"/> MBR2		Lag Sample <input type="checkbox"/> if MBR1 in LEAD: SP-200B <input type="checkbox"/> if MBR2 in LEAD: SP-100A <input checked="" type="checkbox"/>		Sample Collection Time: <u>9:00</u>								
Parameter	Units	Influent	*Lead Reactor	*Lag Reactor	Aeration	Media Filter Effluent	Post Sodium Hypo	Finished Water	GAC 1 Effluent	GAC 2 Effluent	IX 1 Effluent	Permitted Outfall
pH	(std units)	7.52	7.46	7.81	8.01	7.95		7.89				7.00
Temperature	(°C)	19.9	20.7	22.0	22.0	22.1		21.9				22.3
ORP	(mV)	175	-370	-540	-285	-20		224				
Dissolved Oxygen	(mg/L)	9	1.5	0.1	5.5	6		8				
Nitrate + Nitrite	(mg/L-N)	8.2	2.2	0.4				0.2				
Nitrite	(mg/L-N)	0	0.4	0				0				
Sulfide	(mg/L)	0	0	0	0			0				
Turbidity	(NTU)	0.469			1.13	0.503		0.429				
Chlorine Residual	(mg/L)						2.6	1.1				

* Signifies MBR1 or MBR2 depending on if reactor is in the lead or lag position - this changes every 96 hours

Note: shaded boxes are to remain blank

Treatment System Inspection		
Outlet Totalizer	gal	58999.00
Target Flow Rate	gpm	15
Internal Recycle Rate	gpm	280
MBfR 1 pH	std units	7.2
MBfR 2 pH	std units	7.2
MBfR 1 ORP	mV	-348
MBfR 2 ORP	mV	-165
Nitrate Frequency	Hz	
Last N Feed	ppm (N)	7.82
Last N R1	ppm (N)	0.19
Last N R2	ppm (N)	1.65
MBfR1 Sparge Rate	mm	280
MBfR2 Sparge Rate	mm	280
Phosphate Pump Settings	spm / % stroke	20 / 50
Phosphate Concentration at Strainer	mg/LPO4	1.4
Aeration Tank Air Flow	scfm	3.3
Air Tank Pressure	psig	2.2
Target Media Filter Flow Rate	gpm	14
Media Filter Inlet Pressure	psig	7.1
Media Filter Outlet Pressure	psig	5.1
Sodium Hypo Pump Settings	spm / % stroke	30 / 100
Coagulant Tank Level	gal	—
Coagulant Pump Settings		
CO2 Cylinder Pressure	psi	300/59
H2 Cylinder Pressure	psi	224/91
N2 Pressure	psi	325/172
N2 Flow Rate	scfm	

Post Finished Water System Inspection		
collect while sump is running		
Bag Filter ΔP	psi	3
GAC-1 Pressure	psig	16
GAC-2 Pressure	psig	14
IX-1 Pressure	psig	14

Feed Tank Additions		
	H3PO4	Sodium Hypo
me	NONE	NONE
tial Tank Level (gal)		
ock Added		
ype of Water Used For lution		
lume Dilution Added (al)		
tal Volume Added (al)		
nal Tank Level (al)		

Backwash Record		
Backwash start time: _____		
Backwash duration	min	
Initial Product Tank Level	gal	
Final Product Tank Level	gal	
Time of sample collection:		
Location	Turbidity (NTU)	TSS Collected?
MBfR Solids Drain		<input type="checkbox"/> Yes <input checked="" type="checkbox"/> No
Filter Backwash		<input type="checkbox"/> Yes <input checked="" type="checkbox"/> No

NOTES:
 Sodium Hypo pump OFF IN THE AM. COM PLUGGED IT BACK IN. APT HAS EXPLAINED THAT A LEAK WAS DETECTED AT SODIUM HYPO INJECTION POINT AND WAS CLOSED YESTERDAY BEFORE

Inventory	
Type	Check
H3PO4 Stock (gal)	4
Sodium Hypo Stock (gal)	40
Additional Field Test Kits needed?	Dissolved Oxygen
	Nitrate + Nitrite
	Nitrite
	Chlorine
	o-Phosphate

NOTES CONT. -

HE LEFT. 10:00 - CAMERON SAREWJ ONSITE. HE WAS GIVEN A TOUR OF THE ENTIRE FACILITY AND WALKED THROUGH THE PROCESS. CAMERON SNAPPED PHOTOS OF THE SYSTEM. RICH B. ONSITE TO TEST AND INSTALL FILTER AID PUMP. RICH STARTS FILTER AID PUMP AT 1:55 PM, DOSING RATE INFO BELOW -
CDM AND APT TEST NEW LEVEL OF CONTAINMENT FLOAT SWITCH. CDM DETERMINED ROPE ON THE FLOAT SWITCH WILL NOT ENGAGE WHEN INVERTED. DUE TO THE SIZE OF THE FLOAT (3" BOUND CYLINDER) THE ROPE MUST BE LENGTHENED FOR IT TO BE ENGAGED. CDM/APT HAS LENGTHEN THE ROPE AND LOWERED THE PIVOT/CONNECTION POINT. FLOAT NOW ENGAGES AT APPROX. 7"-8" OF STANDING WATER. APT HAS INSTALL A SECONDARY LEVEL SWITCH WHICH WILL ENGAGE AT 4"-5".

DOSING RATE: 3 ml/min.

DOSING CONC. : 0.5 ml/L

FEED CONC. : 0.10%

Date: 9/2/11

Time: 9:00 AM

Operator: BEROKOFF

see back

Field Samples													
Calibration	pH calibration?	<input checked="" type="checkbox"/> Yes <input type="checkbox"/> No	ORP calibration?	<input checked="" type="checkbox"/> Yes <input type="checkbox"/> No	Turbidity calibration?	<input checked="" type="checkbox"/> Yes <input type="checkbox"/> No							
	Standards:	<input checked="" type="checkbox"/> 4 <input type="checkbox"/> 7 <input checked="" type="checkbox"/> 10	Temp (Deg C):	<u>22.0</u>	Standards:	<input type="checkbox"/> 0 <input type="checkbox"/> 0.2 <input type="checkbox"/> 0.4 <input type="checkbox"/> 0.6 <input type="checkbox"/> 1.0							
	Standard Reading:	4: <u>4.01</u> 7: <u>N/A</u> 10: <u>10.16</u>	Standard Reading:	200: <u>218</u>	Standard Reading:	0: _____ 1: _____							
Lead Sample <input type="checkbox"/> Lag Sample <input type="checkbox"/> Lead Reactor: <input type="checkbox"/> MBfR1 <input checked="" type="checkbox"/> MBfR2 <u>SP-100B</u> if MBfR1 in LEAD: SP-200B <input type="checkbox"/> <u>SP</u> Sample Collection Time: <u>10 AM</u> SP-100A <input type="checkbox"/> if MBfR2 in LEAD: SP-100B <input type="checkbox"/> <u>200A</u>													
Sample Data	Parameter	Units	Influent	*Lead Reactor	*Lag Reactor	Aeration	Media Filter Effluent	Post Sodium Hypo	Finished Water	GAC 1 Effluent	GAC 2 Effluent	IX 1 Effluent	Permitted Outfall
	pH	(std units)	7.64	7.56	7.70	8.00	7.88		7.97				7.87
	Temperature	(°C)	19.9	21.5	22.7	22.6	22.9		23.4				22.9
	ORP	(mV)	454	-380	-550	-250	38		681				
	Dissolved Oxygen	(mg/L)	9	1.5	0.1	6.0	5.0		5.5				
	Nitrate + Nitrite	(mg/L-N)	6.0	3.0	0.0				0.25				
	Nitrite	(mg/L-N)	0	0.6	0.05				0				
	Sulfide	(mg/L)	0	0	0.6	0.3			0				
	Turbidity	(NTU)	-			1.17	0.257		0.251				
	Chlorine Residual	(mg/L)							3.75	1.75			

* Signifies MBfR 1 or MBfR 2 depending on if reactor is in the lead or lag position - this changes every 96 hours

Note: shaded boxes are to remain blank

Treatment System Inspection		
Outlet Totalizer	gal	5942400
Target Flow Rate	gpm	15
Internal Recycle Rate	gpm	280
MBfR 1 pH	std units	7.2
MBfR 2 pH	std units	7.2
MBfR 1 ORP	mV	-331
MBfR 2 ORP	mV	-51
Nitrate Frequency	Hz	-
Last N Feed	ppm (N)	7.78
Last N R1	ppm (N)	0.25
Last N R2	ppm (N)	2.72
MBfR1 Sparge Rate	mm	280
MBfR2 Sparge Rate	mm	280
Phosphate Pump Settings	spm	20
	% stroke	30
Phosphate Concentration at Strainer	mg/LPO4	2.0
Aeration Tank Air Flow	scfm	3.2
Air Tank Pressure	psig	2.2
Target Media Filter Flow Rate	gpm	14
Media Filter Inlet Pressure	psig	7.5
Media Filter Outlet Pressure	psig	5.0
Sodium Hypo Pump Settings	spm	30
	% stroke	100
Coagulant Tank Level	gal	1
Coagulant Pump Settings	ML/MIN	5
CO2 Cylinder Pressure	psi	80
H2 Cylinder Pressure	psi	890
N2 Pressure	psi	175
N2 Flow Rate	scfm	-

Post Finished Water System Inspection		
Collect while sump is running		
Bag Filter ΔP	psi	3
GAC-1 Pressure	psig	16
GAC-2 Pressure	psig	11
IX-1 Pressure	psig	2.3

Backwash Record		
Backwash start time:	12:28 PM	
Backwash duration	min	
Initial Product Tank Level	gal	
Final Product Tank Level	gal	
Time of sample collection:		
Location	Turbidity (NTU)	TSS Collected?
MBfR Solids Drain	SEE BAK	<input checked="" type="checkbox"/> Yes <input type="checkbox"/> No
Filter Backwash	-	<input type="checkbox"/> Yes <input checked="" type="checkbox"/> No

Inventory		
Type	Check	
H3PO4 Stock (gal)	<input checked="" type="checkbox"/>	
Sodium Hypo Stock (gal)	<input checked="" type="checkbox"/>	
Additional Field Test Kits Needed?	Dissolved Oxygen	<input checked="" type="checkbox"/>
	Nitrate + Nitrite	<input checked="" type="checkbox"/>
	Nitrite	<input checked="" type="checkbox"/>
	Sump	<input checked="" type="checkbox"/>
	Chlorine	<input checked="" type="checkbox"/>
	o-Phosphate	<input checked="" type="checkbox"/>

NOTES: APT ON SITE TO REFILL FILTER AID AND ADJUST PUMP SETTINGS TO ACCOMMODATE FOR THE INCREASED CONCENTRATION. CDM PERFORMED BACKWASH ON MBfR AND TOOK ~~SAMPLES FOR~~ TURBIDITY MEASUREMENTS (SEE REVERSE).

Feed Tank Additions		
	H3PO4	Sodium Hypo
Time	1:30 PM	1:30 PM
Initial Tank Level (gal)	2.8	25
Stock Added	250	-
Type of Water Used For Dilution	INF	-
Volume Dilution Added (gal)	2.2	-
Total Volume Added (gal)	2.2	-
Final Tank Level (gal)	5.0	25

NOTES CONT...

TEST AMERICA DID NOT SLOT US IN FOR COURIER PICK-UP TODAY. THEY WILL SEND SOMEONE FROM LAB TO PICK UP @ CDM RANCHO OFFICE LATER TODAY OR TUESDAY MORNING.

SAMPLE	TURB (NTU)
LAG 1ST DRAIN:	12.6
LAG 2ND DRAIN	14.6
LEAD 1ST DRAIN	3.4
LEAD 2ST DRAIN	7.11

TURBIDITY CALIBRATION: YES NO
 STANDARDS: < 0.1 20 200 1000
 4000
 STANDARD READING: 0.107 0.301
 0.491 1.0
 0.107% _____ 0.301% _____ 0.491% _____ 1.0% _____

Date: 9/7/11

Time: 9:00

Operator: ARUCIAN

Field Samples

Calibration	pH calibration? <input type="checkbox"/> Yes <input checked="" type="checkbox"/> No		ORP calibration? <input type="checkbox"/> Yes <input checked="" type="checkbox"/> No		Turbidity calibration? <input type="checkbox"/> Yes <input checked="" type="checkbox"/> No							
	Standards: <input type="checkbox"/> 4 <input type="checkbox"/> 7 <input type="checkbox"/> 10		Temp (Deg C): _____		Standards: <input type="checkbox"/> 0 <input type="checkbox"/> 0.2 <input type="checkbox"/> 0.4 <input type="checkbox"/> 0.6 <input type="checkbox"/> 1.0							
Standard Reading: 4: _____ 7: _____ 10: _____		Standard Reading: 200: _____		Standard Reading: 0: _____ 1: _____								
Lead Reactor: <input checked="" type="checkbox"/> MfBR1 <input type="checkbox"/> MfBR2		Lag Sample		Sample Collection Time: <u>10:30</u>								
		if MfBR1 in LEAD: SP-200B <input checked="" type="checkbox"/>		if MfBR2 in LEAD: SP-100B <input type="checkbox"/>								
		SP-100A <input checked="" type="checkbox"/>										
Parameter	Units	Influent	*Lead Reactor	*Lag Reactor	Aeration	Media Filter Effluent	Post Sodium Hypo	Finished Water	GAC 1 Effluent	GAC 2 Effluent	IX 1 Effluent	Permitted Outfall
pH	(std units)	7.59	7.65	7.60	7.90	7.82		7.72				7.64
Temperature	(°C)	19.2	21.8	23.5	23.0	23.6		23.2				23.5
ORP	(mV)	60	-270	-515	-245	-90		120				
Dissolved Oxygen	(mg/L)	9	0.9	0.10	4.5	6		8				
Nitrate + Nitrite	(mg/L-N)	7.5	4.1	0.8				0.6				
Nitrite	(mg/L-N)	0	0.6	0.1				0				
Sulfide	(mg/L)	0	0	0.3	0.1			0				
Turbidity	(NTU)	0.351			0.924	0.409		0.311				
Chlorine Residual	(mg/L)						0.9	0.4				

* Signifies MfBR 1 or MfBR 2 depending on if reactor is in the lead or lag position - this changes every 96 hours

Note: shaded boxes are to remain blank

Outlet Totalizer	gal	6048200
Target Flow Rate	gpm	15
Internal Recycle Rate	gpm	280
MBfR 1 pH	std units	7.2
MBfR 2 pH	std units	7.2
MBfR 1 ORP	mV	102
MBfR 2 ORP	mV	-472
Nitrate Frequency	Hz	---
Last N Feed	ppm (N)	7.71
Last N R1	ppm (N)	3.82
Last N R2	ppm (N)	0.66
MBfR1 Sparge Rate	mm	280
MBfR2 Sparge Rate	mm	280
Phosphate Pump Settings	spm	20
	% stroke	30
Phosphate Concentration at Strainer	mg/LPO4	1.4
Aeration Tank Air Flow	scfm	3.2
Air Tank Pressure	psig	2.2
Target Media Filter Flow Rate	gpm	14.0
Media Filter Inlet Pressure	psig	9.5
Media Filter Outlet Pressure	psig	5.0
Sodium Hypo Pump Settings	spm	30
	% stroke	100
Coagulant Tank Level	gal	1
Coagulant Pump Settings	4 mL/min	
CO2 Cylinder Pressure	psi	105
H2 Cylinder Pressure	psi	91
N2 Pressure	psi	175
N2 Flow Rate	scfm	

Collect while sump is running		
Bag Filter ΔP	psi	4
GAC-1 Pressure	psig	17
GAC-2 Pressure	psig	12
IX-1 Pressure	psig	3

Backwash start time:		
Backwash duration	min	
Initial Product Tank Level	gal	
Final Product Tank Level	gal	
Time of sample collection: <u>11:15</u>		
Location	Turbidity (NTU)	TSS Collected?
MBfR Solids Drain		<input type="checkbox"/> Yes <input type="checkbox"/> No
Filter Backwash		<input type="checkbox"/> Yes <input type="checkbox"/> No

Type	Check	
H3PO4 Stock (gal)	4	
Sodium Hypo Stock (gal)	30	
Additional Field Test Kits Needed?	Dissolved Oxygen	<input checked="" type="checkbox"/>
	Nitrate + Nitrite	<input checked="" type="checkbox"/>
	Nitrite	<input checked="" type="checkbox"/>
	Sulfide	<input checked="" type="checkbox"/>
	Chlorine	<input checked="" type="checkbox"/>
	o-Phosphate	<input checked="" type="checkbox"/>

	H3PO4	Sodium Hypo
Time	1:45	1:45
Initial Tank Level (gal)	1.8	15
Stock Added (mL)	150	
Type of Water Used For Dilution	INF	
Volume Dilution Added (gal)	3.2	
Total Volume Added (gal)	3.2	
Final Tank Level (gal)	5.0	↓

NOTES:
 RICHARD & RICH ONSITE TO CHECK PERFORMANCE OF COAGULANT PUMP. MEDIA FILTER IS SHOWING A DP OF 4.5 PSI (NORMALLY 2-2.5PSI). APT REQUESTED THAT CO2 REWARD DELIVERY PRESSURE BE LOWERED



TO 75 PSI FROM 105 PSI. APT OFFSITE @ 11:30.
1:50 - APT INSTRUCTED CDM TO LOWER FEED FLOW TO
10 GPM. CDM HAS ADJUSTED THE LACT REACTOR OUTLET
FLOW BY "THROTTLING" VALVE ON THE STAND PIPE
PRIOR TO THE AERATION TANK. CDM HAS ALSO
REDUCED THE MEDIA FILTER FLOW RATE TO 9.0 GPM,
BY THROTTLING THE VALVE BETWEEN THE MEDIA FILTER
AND PRODUCT TANK.

Date: 9/9/11

Time: 9:00

Operator: ARUCAN

Field Samples

Calibration	pH calibration? <input checked="" type="checkbox"/> Yes <input type="checkbox"/> No		ORP calibration? <input checked="" type="checkbox"/> Yes <input type="checkbox"/> No		Turbidity calibration? <input type="checkbox"/> Yes <input checked="" type="checkbox"/> No							
	Standards: <input type="checkbox"/> 4 <input type="checkbox"/> 7 <input type="checkbox"/> 10		Temp (Deg C): _____		Standards: <input type="checkbox"/> 0 <input type="checkbox"/> 0.2 <input type="checkbox"/> 0.4 <input type="checkbox"/> 0.6 <input type="checkbox"/> 1.0							
Standard Reading: 4: _____ 7: _____ 10: _____		Standard Reading: 200: _____		Standard Reading: 0: _____ 1: _____								
Lead Reactor: <input type="checkbox"/> MfBR1 <input checked="" type="checkbox"/> MfBR2		Lead Sample: SP-200A <input type="checkbox"/> SP-200B <input type="checkbox"/> SP-100A <input type="checkbox"/> SP-100B <input type="checkbox"/>		Lag Sample: _____		Sample Collection Time: <u>10:00</u>						
Parameter	Units	Influent	*Lead Reactor	*Lag Reactor	Aeration	Media Filter Effluent	Post Sodium Hypo	Finished Water	GAC 1 Effluent	GAC 2 Effluent	IX 1 Effluent	Permitted Outfall
pH	(std units)	7.54	7.43	7.65	7.99	7.84		7.83				7.48
Temperature	(°C)	19.0	22.3	24.2	24.1	24.3		24.1				24.2
ORP	(mV)	135	-435	-520	-231	-80		290				
Dissolved Oxygen	(mg/L)	9	2.5	.15	6.5	7.0		8.0				
Nitrate + Nitrite	(mg/L-N)	8.5	2.8	0.1				0				
Nitrite	(mg/L-N)	0	0.4	0				0				
Sulfide	(mg/L)	0.297	0	0.8	0.6			0				
Turbidity	(NTU)	0.297			1.13	0.306		0.276				
Chlorine Residual	(mg/L)						0.6	0.2				

* Signifies MBfR 1 or MBfR 2 depending on if reactor is in the lead or lag position - this changes every 96 hours

Note: shaded boxes are to remain blank

Treatment System Inspection

Outlet Totalizer	gal	607850
Target Flow Rate	gpm	10
Internal Recycle Rate	gpm	280
MBfR 1 pH	std units	7.2
MBfR 2 pH	std units	7.2
MBfR 1 ORP	mV	-288
MBfR 2 ORP	mV	-50
Nitrate Frequency	Hz	
Last N Feed	ppm (N)	7.43
Last N R1	ppm (N)	0.33
Last N R2	ppm (N)	2.18
MBfR1 Sparge Rate	mm	280
MBfR2 Sparge Rate	mm	280
Phosphate Pump Settings	spm / % stroke	18 / 30
Aeration Tank Air Flow	scfm	3.3
Air Tank Pressure	psig	2.2
Target Media Filter Flow Rate	gpm	9
Media Filter Inlet Pressure	psig	5.7
Media Filter Outlet Pressure	psig	2.1
Sodium Hypo Pump Settings	spm / % stroke	30 / 100
Coagulant Tank Level	gal	3.5
Coagulant Pump Settings	ml/min	4
CO2 Cylinder Pressure	psi	73
H2 Cylinder Pressure	psi	91
N2 Pressure	psi	175
N2 Flow Rate	scfm	

Post Finished Water System Inspection

Collect while sump is running

Bag Filter ΔP	psi	3
GAC-1 Pressure	psig	15
GAC-2 Pressure	psig	14
IX-1 Pressure	psig	3

Feed Tank Additions

	H3PO4	Sodium Hypo
Time	2:30	2:45
Initial Tank Level (gal)	3.5	11
Stock Added	we 120	6x 2.5 GALS
Type of Water Used For Dilution	INF	MEDIA
Volume Dilution Added (gal)	1.5	16.5
Total Volume Added (gal)	1.5	16.2
Final Tank Level (gal)	5	30

SPARGE Backwash Record

Backwash start time: 12:00

Backwash duration	min	N/A
Initial Product Tank Level	gal	N/A
Final Product Tank Level	gal	N/A
Time of sample collection:		
Location	Turbidity (NTU)	TSS Collected?
MBfR Solids Drain	ON BACK	<input checked="" type="checkbox"/> Yes <input type="checkbox"/> No
Filter Backwash		<input type="checkbox"/> Yes <input checked="" type="checkbox"/> No

Inventory

Type	Check	
H3PO4 Stock (gal)	4	
Sodium Hypo Stock (gal)	28	
Additional Field Test Kits Needed?	Dissolved Oxygen	<input checked="" type="checkbox"/>
	Nitrate + Nitrite	<input checked="" type="checkbox"/>
	Nitrite	<input checked="" type="checkbox"/>
	Sulfide	<input checked="" type="checkbox"/>
	Chlorine	<input checked="" type="checkbox"/>
o-Phosphate	<input checked="" type="checkbox"/>	

NOTES:

CDM ON SITE AT 8:00 TO INSTALL SHADE ON CHEMICAL PAD. APT INSTRUCTED CDM TO CLOSE MEDIA FILTER VALVE JUST ENOUGH TO MAINTAIN 30 PSI WHEN BACK-WASHING.

APT INFORMED CDM TO NOT PERFORM
 BACKWASH DUE TO RECENT BACKWASH YESTERDAY,
 DURING THE SPARGE PROCESS, THE H₂ LEL ALARM
 HAD GONE ON AND WAS @ 37% AT STEP
 2, SPARGE LAG. AERATION TANK WAS LOWER
 AND CDM NOTICED WHITE FILM ON TANK. PHOTOS
 ATTACHED.

LOCATION	TURBIDITY SS
LAG 1	15.7
LAG 2	17.2
LEAD 1	3.92
LEAD 2	6.52
AERATION	1.81
MEDIA -FILTERS	0.489

Date: 9/12/11

Time: 9:00

Operator: ARUCAN

Field Samples													
Calibration	pH calibration? <input checked="" type="checkbox"/> Yes <input type="checkbox"/> No			ORP calibration? <input checked="" type="checkbox"/> Yes <input type="checkbox"/> No			Turbidity calibration? <input type="checkbox"/> Yes <input checked="" type="checkbox"/> No						
	Standards: <input checked="" type="checkbox"/> 4 <input checked="" type="checkbox"/> 7 <input checked="" type="checkbox"/> 10			Temp (Deg C): <u>18.6</u>			Standards: <input type="checkbox"/> 0 <input type="checkbox"/> 0.2 <input type="checkbox"/> 0.4 <input type="checkbox"/> 0.6 <input type="checkbox"/> 1.0						
Standard Reading: 4: <u>4.20</u> 7: <u>7.15</u> 10: <u>10.11</u>			Standard Reading: <u>200</u> - <u>216</u>			Standard Reading: 0: _____ 1: _____							
Lead Reactor: <input checked="" type="checkbox"/> MfBR1 <input type="checkbox"/> MfBR2 Lead Sample: <u>SP-200A</u> <input checked="" type="checkbox"/> <u>SP-200B</u> <input type="checkbox"/> Lag Sample: <u>SP-100A</u> <input type="checkbox"/> <u>SP-100B</u> <input type="checkbox"/>													
											Sample Collection Time: <u>11:30</u>		
Sample Data	Parameter	Units	Influent	*Lead Reactor	*Lag Reactor	Aeration	Media Filter Effluent	Post Sodium Hypo	Finished Water	GAC 1 Effluent	GAC 2 Effluent	IX 1 Effluent	Permitted Outfall
	pH	(std units)	7.50	7.65	7.38	7.82	7.65		7.68				7.60
	Temperature	(°C)	19.0	21.9	23.9	23.7	23.8		23.7				23.2
	ORP	(mV)	110	-315	-390	-275	-232		355				
	Dissolved Oxygen	(mg/L)	9	0.7	0.2	5.5	6		7				
	Nitrate + Nitrite	(mg/L-N)	8.5	1.6	0				0				
	Nitrite	(mg/L-N)	0	0.2	0				0				
	Sulfide	(mg/L)	0	0	2.0	1.1			0				
	Turbidity	(NTU)	0.368			1.78	0.385		0.343				
	Chlorine Residual	(mg/L)							0.5	0.2			

* Signifies MBfR 1 or MBfR 2 depending on if reactor is in the lead or lag position - this changes every 96 hours

Note: shaded boxes are to remain blank

Post Finished Water System Inspection		
Collect while sump is running		
Bag Filter ΔP	psi	4
GAC-1 Pressure	psig	16
GAC-2 Pressure	psig	14
IX-1 Pressure	psig	3

Backwash Record		
Backwash start time:		
Backwash duration	min	
Initial Product Tank Level	gal	
Final Product Tank Level	gal	
Time of sample collection:		
Location	Turbidity (NTU)	TSS Collected?
MBfR Solids Drain	N/A	<input type="checkbox"/> Yes <input type="checkbox"/> No
Filter Backwash	N/A	<input type="checkbox"/> Yes <input type="checkbox"/> No

Inventory		
Type	Check	
H3PO4 Stock (gal)	4	
Sodium Hypo Stock (gal)	30	
Additional Field Test Kits Needed?	Dissolved Oxygen	<input checked="" type="checkbox"/>
	Nitrate + Nitrite	<input checked="" type="checkbox"/>
	Nitrite	<input checked="" type="checkbox"/>
	Sulfide	NEED MORE!
	Chlorine	<input checked="" type="checkbox"/>
	o-Phosphate	<input checked="" type="checkbox"/>

Feed Tank Additions		
	H3PO4	Sodium Hypo
Time	1:45	1:30
Initial Tank Level (gal)	3	27-25
Stock Added	100	0
Type of Water Used For Dilution	INFLUENT	0
Volume Dilution Added (gal)	2.0	0
Total Volume Added (gal)	2.0	0
Final Tank Level (gal)	5.0	27-25

NOTES:
 MARIANNE. APT INFORMED CDM THAT MEDIA FILTERS PERFORMED BACKWASH LAST NIGHT - CDM NOTED THAT COAGULANT TANK IS EMPTY AND INFORMED APT. CDM HAS ACCIDENTALLY NOT ENGAGED

Treatment System Inspection		
Outlet Totalizer	gal	6121600
Target Flow Rate	gpm	10
Internal Recycle Rate	gpm	280
MBfR 1 pH	std units	7.2
MBfR 2 pH	std units	7.2
MBfR 1 ORP	mV	-272
MBfR 2 ORP	mV	-452
Nitrate Frequency	Hz	
Last N Feed	ppm (N)	7.93
Last N R1	ppm (N)	1.20
Last N R2	ppm (N)	0.91
MBfR1 Sparge Rate	mm	280
MBfR2 Sparge Rate	mm	280
Phosphate Pump Settings	spm	20
	% stroke	30
Aeration Tank Air Flow	scfm	3.3
Air Tank Pressure	psig	2.2
Target Media Filter Flow Rate	gpm	9.0
Media Filter Inlet Pressure	psig	2.6
Media Filter Outlet Pressure	psig	2.1
Sodium Hypo Pump Settings	spm	30
	% stroke	100
Coagulant Tank Level	gal	0
Coagulant Pump Settings	nd/wds	4
CO2 Cylinder Pressure	psi	72
H2 Cylinder Pressure	psi	91
N2 Pressure	psi	175
N2 Flow Rate	scfm	

PHOSPHATE FEED CONC (PPM) = 1.1

NOTES CONT.

THE SECONDARY CONTAINMENT SWITCH, THE SYSTEM WAS SHUT OFF. CDM HAD RESTARTED THE SYSTEM. CHLORINATION FEED CHANGED TO 40 STROKES/MIN AND 100% STROKE LENGTH

CONTACT
EQUIPCO FOR STAB METER.

Date: 9-14-11

Time: 10:30AM

Operator: BEROKOFF

Field Samples													
Calibration	pH calibration? <input type="checkbox"/> Yes <input checked="" type="checkbox"/> No			ORP calibration? <input type="checkbox"/> Yes <input checked="" type="checkbox"/> No			Turbidity calibration? <input checked="" type="checkbox"/> Yes <input type="checkbox"/> No						
	Standards: <input type="checkbox"/> 4 <input type="checkbox"/> 7 <input type="checkbox"/> 10			Temp (Deg C): _____			Standards: <input checked="" type="checkbox"/> 0 <input checked="" type="checkbox"/> 20 <input checked="" type="checkbox"/> 200 <input checked="" type="checkbox"/> 1000 <input checked="" type="checkbox"/> 4000						
Standard Reading: 4: _____ 7: _____ 10: _____			Standard Reading: <u>200</u> → <u>220</u>			Readings: 0.107: _____ 0.301: _____ 0.491: _____							
Sample Data	Lead Reactor: <input checked="" type="checkbox"/> MIBR1 <input type="checkbox"/> MIBR2 Lag Sample: <input type="checkbox"/> MIBR1 <input type="checkbox"/> MIBR2 if MIBR1 in LEAD: SP-200B <input checked="" type="checkbox"/> if MIBR2 in LEAD: SP-100A <input type="checkbox"/> if MIBR2 in LEAD: SP-100B <input type="checkbox"/>												
	Sample Collection Time: <u>10:30</u>												
	Parameter	Units	Influent	*Lead Reactor	*Lag Reactor	Aeration	Media Filter Effluent	Post Sodium Hypo	Finished Water	GAC 1 Effluent	GAC 2 Effluent	IX 1 Effluent	Permitted Outfall
	pH	(std units)	7.64	7.48	7.37	7.82	7.66		7.73				7.67
	Temperature	(°C)	19.8	22.2	24.2	24.0	24.1		24.0				24.1
	ORP	(mV)	-20	-192	-293	-247	-134		318				
	Dissolved Oxygen	(mg/L)	9	0.9	0.1	7.0	2.5		3.0				
	Nitrate + Nitrite	(mg/L-N)	9	3	0				0.2				
	Nitrite	(mg/L-N)	0	0.75	0.1				0				
	Sulfide	(mg/L)	0	0	1.0	0.5			0				
	Turbidity	(NTU)	0.107			1.88	0.39		0.29				
	Chlorine Residual	(mg/L)						0.6	0.2				

* Signifies MIBR 1 or MIBR 2 depending on if reactor is in the lead or lag position - this changes every 96 hours

Note: shaded boxes are to remain blank

Treatment System Inspection		
Outlet Totalizer	gal	6150600
Target Flow Rate	gpm	10
Internal Recycle Rate	gpm	280
MBfR 1 pH	std units	7.2
MBfR 2 pH	std units	7.2
MBfR 1 ORP	mV	-81
MBfR 2 ORP	mV	-324
Nitrate Frequency	Hz	-
Last N Feed	ppm (N)	7.95
Last N R1	ppm (N)	2.26
Last N R2	ppm (N)	0.47
MBfR1 Sparge Rate	mm	280
MBfR2 Sparge Rate	mm	280
Phosphate Pump Settings	spm	20
	% stroke	30
Phosphate Concentration at Strainer	mg/LPO4	2.0 2.0
Aeration Tank Air Flow	scfm	3.2
Air Tank Pressure	psig	2.2
Target Media Filter Flow Rate	gpm	9
Media Filter Inlet Pressure	psig	3.0
Media Filter Outlet Pressure	psig	2.2
Sodium Hypo Pump Settings	spm	40
	% stroke	100
Coagulant Tank Level	gal	0.5
Coagulant Pump Settings		6 mL/MIN
CO2 Cylinder Pressure	psi	75
H2 Cylinder Pressure	psi	90
N2 Pressure	psi	175
N2 Flow Rate	scfm	-

Post Finished Water System Inspection		
Collect while sump is running		
Bag Filter ΔP	psi	3-4
GAC-1 Pressure	psig	16
GAC-2 Pressure	psig	14
IX-1 Pressure	psig	3

Backwash Record		
Backwash start time: _____		
Backwash duration	min	
Initial Product Tank Level	gal	
Final Product Tank Level	gal	
Time of sample collection: _____		
Location	Turbidity (NTU)	TSS Collected?
Lead Purge 1		<input type="checkbox"/> Yes <input type="checkbox"/> No
Lead Purge 2		<input type="checkbox"/> Yes <input type="checkbox"/> No
Lag Purge 1		<input type="checkbox"/> Yes <input type="checkbox"/> No
Lag Purge 2		<input type="checkbox"/> Yes <input type="checkbox"/> No
Media Filter		<input type="checkbox"/> Yes <input type="checkbox"/> No

Inventory		
Type	Check	
H3PO4 Stock (gal)	506	
Sodium Hypo Stock (gal)	30	
Additional Field Test Kits Needed?	Dissolved Oxygen	4 ea
	Nitrate + Nitrite	9
	Nitrite	9
	Sulfide	1
	Chlorine	6
	o-Phosphate	3

Feed Tank Additions		
	H3PO4	Sodium Hypo
Time		
Initial Tank Level (gal)		
Stock Added		
Type of Water Used For Dilution		
Volume Dilution Added (gal)		
Total Volume Added (gal)		
Final Tank Level (gal)		

NOTES:
 CCI ON SITE TO INSTALL NEW FLOAT SWITCH FOR SECONDARY CONTAINMENT. APT ON SITE TO CONSTRUCT SHADE BARRIER ALONG NORTHERN END OF MBfR UNIT. INCREASED SODIUM HYPO PUMP SETTINGS TO 60 spm @ 100% SL (FROM 40 spm/100%). MEASURED CL2 RESIDUAL DIRECTLY AFTER MEDIA FILTER = 0.625 mg/L. THERE WAS NO TARP COVERING LID

Note: There are 3785 mL per gallon.

NOTES CONT...

PORTION OF SODIUM HYPO TANK WHICH WOULD LEAD THE CONCENTRATION TO DEGRADE. COVERED LID W/ BLACK TRASH BAG IN ORDER TO BLOCK LIGHT. CCI WAS STILL ON SITE ~~WHEN~~ @ 1:30pm TRYING TO TROUBLESHOOT THE RELAYS FOR THE HIGH LEVEL SWITCH.

Date: 9-16-11

Time: 9AM

Operator: BEROKOFF

Field Samples													
Calibration	pH calibration? <input type="checkbox"/> Yes <input checked="" type="checkbox"/> No			ORP calibration? <input type="checkbox"/> Yes <input checked="" type="checkbox"/> No			Turbidity calibration? <input type="checkbox"/> Yes <input checked="" type="checkbox"/> No						
	Standards: <input type="checkbox"/> 4 <input type="checkbox"/> 7 <input type="checkbox"/> 10			Temp (Deg C): _____			Standards: <input type="checkbox"/> 0 <input type="checkbox"/> 20 <input type="checkbox"/> 200 <input type="checkbox"/> 1000 <input type="checkbox"/> 4000						
Standard Reading: 4: _____ 7: _____ 10: _____			Standard Reading: <u>200</u> <u>20</u>			Readings: 0.107: _____ 0.301: _____ 0.491: _____							
Sample Data	Lead Sample <input type="checkbox"/> Lag Sample <input type="checkbox"/> Lead Reactor: <input type="checkbox"/> MIBR1 <input checked="" type="checkbox"/> MIBR2 <input type="checkbox"/> SP-100A <input type="checkbox"/> if MIBR1 in LEAD: SP-200B <input type="checkbox"/> if MIBR2 in LEAD: SP-100B <input checked="" type="checkbox"/> Sample Collection Time: <u>9:45</u>												
	Parameter	Units	Influent	*Lead Reactor	*Lag Reactor	Aeration	Media Filter Effluent	Post Sodium Hypo	Finished Water	GAC 1 Effluent	GAC 2 Effluent	IX 1 Effluent	Permitted Outfall
	pH	(std units)	7.63	7.42	7.53	7.83	7.73		7.78				7.86
	Temperature	(°C)	18.9	20.0	21.1	21.1	21.1		20.9				20.8
	ORP	(mV)	130	-285	-430	-195	-88		379				
	Dissolved Oxygen	(mg/L)	9	1.5	0.2	5.5	4.5		4.5				
	Nitrate + Nitrite	(mg/L-N)	9	4.5	0.8				0.7				
	Nitrite	(mg/L-N)	0	0.75	0.4				0				
	Sulfide	(mg/L)	0	0	0.05	0			0				
	Turbidity	(NTU)	-						0.45				
	Chlorine Residual	(mg/L)						0.4	0.05				

* Signifies MBFR 1 or MBFR 2 depending on if reactor is in the lead or lag position - this changes every 96 hours

Note: shaded boxes are to remain blank

Treatment System Inspection		
Outlet Totalizer	gal	6184300
Target Flow Rate	gpm	20
Internal Recycle Rate	gpm	280
MBFR 1 pH	std units	7.2
MBFR 2 pH	std units	7.2
MBFR 1 ORP	mV	-247
MBFR 2 ORP	mV	-81
Nitrate Frequency	Hz	-
Last N Feed	ppm (N)	7.78
Last N R1	ppm (N)	0.80
Last N R2	ppm (N)	3.63
MBFR1 Sparge Rate	mm	280
MBFR2 Sparge Rate	mm	280
Phosphate Pump Settings	spm	30
	% stroke	30
Phosphate Concentration at Strainer	mg/LPO4	30
Aeration Tank Air Flow	scfm	3.2
Air Tank Pressure	psig	2.2
Target Media Filter Flow Rate	gpm	9
Media Filter Inlet Pressure	psig	7.5
Media Filter Outlet Pressure	psig	2.2
Sodium Hypo Pump Settings	spm	60
	% stroke	100
Coagulant Tank Level	gal	1
Coagulant Pump Settings	ML/min	7
CO2 Cylinder Pressure	psi	75
H2 Cylinder Pressure	psi	90
N2 Pressure	psi	161
N2 Flow Rate	scfm	-

Post Finished Water System Inspection		
Collect while sump is running		
Bag Filter ΔP	psi	3
GAC-1 Pressure	psig	14
GAC-2 Pressure	psig	9
IX-1 Pressure	psig	1.1

Backwash Record		
Backwash start time:	2:00PM	
Backwash duration	min	
Initial Product Tank Level	gal	
Final Product Tank Level	gal	
Time of sample collection:	2:00PM	
Location	Turbidity (NTU)	TSS Collected?
Lead Purge 1		<input type="checkbox"/> Yes <input type="checkbox"/> No
Lead Purge 2		<input type="checkbox"/> Yes <input type="checkbox"/> No
Lag Purge 1		<input type="checkbox"/> Yes <input type="checkbox"/> No
Lag Purge 2		<input type="checkbox"/> Yes <input type="checkbox"/> No
Media Filter	17.7	<input checked="" type="checkbox"/> Yes <input type="checkbox"/> No

Inventory		
	Type	Check
Additional Field Test Kits Needed?	H3PO4 Stock (gal)	30 6
	Sodium Hypo Stock (gal)	30 30
	Dissolved Oxygen	3/4
	Nitrate + Nitrite	8
	Nitrite	9
	Sulfide	1
	Chlorine	6
	o-Phosphate	3

Feed Tank Additions		
	H3PO4	Sodium Hypo
Time	2:45	
Initial Tank Level (gal)	2.4	12
Stock Added	160	3.0
Type of Water Used For Dilution	INF	MED. FILT
Volume Dilution Added (gal)	2.6	11.8 15
Total Volume Added (gal)	2.6	18
Final Tank Level (gal)	5.0	30

NOTES:
 CCI INSTALLED NEW FLOAT SWITCH YESTERDAY AND SUCCESSFULLY TESTED IT. APT ON SITE TO PERFORM VARIOUS MAINTENANCE TASKS AND TO MEET WITH VISITORS INTERESTED IN THE TECHNOLOGY. CONDUCTED BATCH TEST ON MBFR; THIS INCLUDED SHUTTING OFF INFLUENT TO MBFR AND WAITING FOR TAKE PERCHLORATE SAMPLES BASED ON MONITORING OF NITRATE LEVELS ON OIT SCREEN (DID THIS FOR R2 FIRST THEN R1).

FOR SEC. CONTAINMENT

Note: There are 3785 mL per gallon.

Date: 9-19-11

Time: 9:15 AM

Operator: BEROKOFF

Treatment System Inspection		
Outlet Totalizer	gal	6209200
Target Flow Rate	gpm	5
Internal Recycle Rate	gpm	280
MBfR 1 pH	std units	-
MBfR 2 pH	std units	7.2
MBfR 1 ORP	mV	-
MBfR 2 ORP	mV	-221
Nitrate Frequency	Hz	-
Last N Feed	ppm (N)	7.98
Last N R1	ppm (N)	0
Last N R2	ppm (N)	0.31
MBfR1 Sparge Rate	mm	280
MBfR2 Sparge Rate	mm	280
Phosphate Pump Settings	spm	20
	% stroke	30
Phosphate Concentration at Strainer	mg/LPO4	3.5
Aeration Tank Air Flow	scfm	3.3
Air Tank Pressure	psig	2.1
Target Media Filter Flow Rate	gpm	4.5
Media Filter Inlet Pressure	psig	10.9
Media Filter Outlet Pressure	psig	1.7
Sodium Hypo Pump Settings	spm	60
	% stroke	100
Coagulant Tank Level	gal	2.5
Coagulant Pump Settings	m ³ /min	4
CO2 Cylinder Pressure	psi	70
H2 Cylinder Pressure	psi	90
N2 Pressure	psi	179
N2 Flow Rate	scfm	-

Field Samples												
Parameter	Units	Influent	*Lead Reactor	*Lag Reactor	Aeration	Media Filter Effluent	Post Sodium Hypo	Finished Water	GAC 1 Effluent	GAC 2 Effluent	IX 1 Effluent	Permitted Outfall
		pH	(std units)	7.67	7.40	-	8.02	7.76		7.88		
Temperature	(°C)	24.0	25.1	-	24.8	25.2		25.4				24.8
ORP	(mV)	86	-293	-	-107	-102		733				
Dissolved Oxygen	(mg/L)	9	0.25	-	6.5	4.5		6.5				
Nitrate + Nitrite	(mg/L-N)	8	0.5	-				0.5				
Nitrite	(mg/L-N)	0	0.1	-				0				
Sulfide	(mg/L)	0	0.1	-	0			0				
Turbidity	(NTU)	0.12			2.87	0.45		0.37				
Chlorine Residual	(mg/L)							>5				>5

* Signifies MBfR 1 or MBfR 2 depending on if reactor is in the lead or lag position - this changes every 96 hours

Note: shaded boxes are to remain blank

Post Finished Water System Inspection		
Collect while sump is running		
Bag Filter ΔP	psi	3
GAC-1 Pressure	psig	15
GAC-2 Pressure	psig	11
IX-1 Pressure	psig	1.8

Backwash Record		
Backwash start time:		
Backwash duration	min	
Initial Product Tank Level	gal	
Final Product Tank Level	gal	
Time of sample collection:		
Location	Turbidity (NTU)	TSS Collected?
Lead Purge 1		<input type="checkbox"/> Yes <input type="checkbox"/> No
Lead Purge 2		<input type="checkbox"/> Yes <input type="checkbox"/> No
Lag Purge 1		<input type="checkbox"/> Yes <input type="checkbox"/> No
Lag Purge 2		<input type="checkbox"/> Yes <input type="checkbox"/> No
Media Filter		<input type="checkbox"/> Yes <input type="checkbox"/> No

Inventory		
Type	Check	
H3PO4 Stock (gal)	~5	
Sodium Hypo Stock (gal)	~27	
Additional Field Test Kits Needed?	Dissolved Oxygen	3/4
	Nitrate + Nitrite	8
	Nitrite	9
	Sulfide	1
	Chlorine	5
	o-Phosphate	3

Feed Tank Additions		
	H3PO4	Sodium Hypo
Time		-
Initial Tank Level (gal)	2.2	2.2
Stock Added (mL)	25	-
Type of Water Used For Dilution	INF	-
Volume Dilution Added (gal)	2.8	-
Total Volume Added (gal)	2.8	-
Final Tank Level (gal)	5.0	2.2

Note: There are 3785 mL per gallon.

NOTES:
 ONLY R2 IS IN OPERATION TODAY (THIS DONE BY DESIGN). WILL ONLY SAMPLE LEAD REACTOR. APT TO PERFORM SIGNIFICANT MAINTENANCE ON WED (9-21). DID NOT ADJUST CHLORINE PUMP SETTINGS ON FRIDAY. PUMP WAS STILL AT 60 SPM, UPON CHECKING RESIDUAL, THE CONCENTRATIONS IN BOTH THE FINISHED WATER TANK AND THE POST MEDIA FILTER WERE >5 PPM. ADJUSTED SETTINGS TO 40 SPM, HOWEVER

DID NOT ADJUST CHLORINE PUMP SETTINGS ON FRIDAY. PUMP WAS STILL AT 60 SPM, UPON CHECKING RESIDUAL, THE CONCENTRATIONS IN BOTH THE FINISHED WATER TANK AND THE POST MEDIA FILTER WERE >5 PPM. ADJUSTED SETTINGS TO 40 SPM, HOWEVER

NOTES CONT...

CONCENTRATION @ POST MEDIA FILTER STILL MEASURED > 5 ppm. UPON ~~LOWERING~~
PUMP SETTINGS TO 20SPM + 100% STRENGTH, POST MEDIA RESIDUAL READ 2.5ppm. WAITED
3 HRS BEFORE TAKING RESIDUAL ON FINISHED WATER TANK \rightarrow 4ppm.

Date: 10/3/11

Time: 7:00

Operator: ARUEAN

Field Samples

Calibration	pH calibration? <input checked="" type="checkbox"/> Yes <input type="checkbox"/> No		ORP calibration? <input checked="" type="checkbox"/> Yes <input type="checkbox"/> No		Turbidity calibration? <input checked="" type="checkbox"/> Yes <input type="checkbox"/> No								
	Standards: <input checked="" type="checkbox"/> 4 <input type="checkbox"/> 7 <input checked="" type="checkbox"/> 10		Temp (Deg C): <u>20.8</u>		Standards: <input type="checkbox"/> 0 <input type="checkbox"/> 20 <input type="checkbox"/> 200 <input type="checkbox"/> 1000 <input type="checkbox"/> 4000								
	Standard Reading: 4: <u>4.1</u> 7: <u>10.02</u>		Standard Reading: <u>200</u> <u>223</u>		Readings: 0.107: <u>133</u> 0.301: <u>341</u> 0.491: <u>506</u>								
	Lead Sample <input checked="" type="checkbox"/> Lag Sample <input type="checkbox"/>		Sample Collection Time: <u>7:30</u>										
	Lead Reactor: <input type="checkbox"/> MfBR1 <input checked="" type="checkbox"/> MfBR2		if MBfR1 in LEAD: SP-200B <input type="checkbox"/> if MBfR2 in LEAD: SP-100A <input checked="" type="checkbox"/>										
Sample Data	Parameter	Units	Influent	*Lead Reactor	*Lag Reactor	Aeration	Media Filter Effluent	Post Sodium Hypo	Finished Water	GAC 1 Effluent	GAC 2 Effluent	IX 1 Effluent	Permitted Outfall
	pH	(std units)	7.48	7.40	7.46	7.94	7.85		21.1				7.59
	Temperature	(°C)	18.6	19.8	20.7	20.8	20.8		7.84				21.1
	ORP	(mV)	130	-255	-566	-120	50		90				
	Dissolved Oxygen	(mg/L)	9	0.2	0	5.5	7		8				
	Nitrate + Nitrite	(mg/L-N)	8.2	3.8	0.4				0.4				
	Nitrite	(mg/L-N)	0	0.8	0.4				0.4				
	Sulfide	(mg/L)	0	0	0	0.3			0				
	Turbidity	(NTU)	4.41			2.96	0.679		0.503				
	Chlorine Residual	(mg/L)							0.3	0			

* Signifies MBfR 1 or MBfR 2 depending on if reactor is in the lead or lag position - this changes every 96 hours

Note: shaded boxes are to remain blank

Post Finished Water System Inspection

Collect while sump is running

Bag Filter ΔP	psi	2
GAC-1 Pressure	psig	16
GAC-2 Pressure	psig	12
IX-1 Pressure	psig	3

After change out of filter

Feed Tank Additions

	H3PO4	Sodium Hypo
Time	7:30	
Initial Tank Level (gal)	0	
Stock Added	400ml	
Type of Water Used For Dilution	INF	
Volume Dilution Added (gal)	5	
Total Volume Added (gal)	5	
Final Tank Level (gal)	5	

Note: There are 3785 mL per gallon.

Backwash Record

Backwash start time:		
Backwash duration	min	
Initial Product Tank Level	gal	
Final Product Tank Level	gal	
Time of sample collection:		
Location	Turbidity (NTU)	TSS Collected?
Lead Purge 1		<input type="checkbox"/> Yes <input type="checkbox"/> No
Lead Purge 2		<input type="checkbox"/> Yes <input type="checkbox"/> No
Lag Purge 1		<input type="checkbox"/> Yes <input type="checkbox"/> No
Lag Purge 2		<input type="checkbox"/> Yes <input type="checkbox"/> No
Media Filter		<input type="checkbox"/> Yes <input type="checkbox"/> No

Inventory

Type	Check	
H3PO4 Stock (gal)	4 ✓	
Sodium Hypo Stock (gal)	15 ✓	
Additional Field Test Kits Needed?	Dissolved Oxygen	✓
	Nitrate + Nitrite	✓
	Nitrite	✓
	Sulfide	✓
	Chlorine	✓
	o-Phosphate	✓

NOTES:

VALVE XV-103 ON MBfR 1 IS UNPLUGGED, CDM NOTIFIED APT. LEAK ON PHOSPHATE PUMP/TANK FOUND. PUMP P-200 IS VERY LOUD, CHLORINE PUMP INJECTION VALVE WAS CLOSED, CDM OPENED.

Treatment System Inspection

Outlet Totalizer	gal	6389700
Target Flow Rate	gpm	10
Internal Recycle Rate	gpm	180
MBfR 1 pH	std units	7.2
MBfR 2 pH	std units	7.2
MBfR 1 ORP	mV	-614
MBfR 2 ORP	mV	-65
Nitrate Frequency	Hz	-
Last N Feed	ppm (N)	7.98
Last N R1	ppm (N)	0.03
Last N R2	ppm (N)	2.64
MBfR1 Sparge Rate	mm	240
MBfR2 Sparge Rate	mm	240
Phosphate Pump Settings	spm	20
	% stroke	30
Phosphate Concentration at Strainer	mg/LPO4	3
Aeration Tank Air Flow	scfm	3.4
Air Tank Pressure	psig	2.1
Target Media Filter Flow Rate	gpm	9
Media Filter Inlet Pressure	psig	10.2
Media Filter Outlet Pressure	psig	1.5
Sodium Hypo Pump Settings	spm	20
	% stroke	100
Coagulant Tank Level	gal	-
Coagulant Pump Settings		OFF
CO2 Cylinder Pressure	psi	91
H2 Cylinder Pressure	psi	92
N2 Pressure	psi	143
N2 Flow Rate	scfm	

Date: 10/5/11

Time: 8:30 AM

Operator: BEROKOFF

Field Samples												
Calibration	pH calibration? <input type="checkbox"/> Yes <input checked="" type="checkbox"/> No			ORP calibration? <input type="checkbox"/> Yes <input checked="" type="checkbox"/> No			Turbidity calibration? <input type="checkbox"/> Yes <input checked="" type="checkbox"/> No					
	Standards: <input type="checkbox"/> 4 <input type="checkbox"/> 7 <input type="checkbox"/> 10			Temp (Deg C): _____			Standards: <input type="checkbox"/> 0 <input type="checkbox"/> 20 <input type="checkbox"/> 200 <input type="checkbox"/> 1000 <input type="checkbox"/> 4000					
Standard Reading: 4: _____ 7: _____ 10: _____			Standard Reading: 200: _____			Readings: 0.107: _____ 0.301: _____ 0.491: _____						
Lead Sample <input type="checkbox"/> Lag Sample <input type="checkbox"/> Lead Reactor: <input type="checkbox"/> MIBR1 if MIBR1 in LEAD: SP-200B <input type="checkbox"/> Sample Collection Time: <u>9:30 AM</u> <input checked="" type="checkbox"/> MIBR2 SP-100A <input type="checkbox"/> if MIBR2 in LEAD: SP-100B <input checked="" type="checkbox"/>												
Parameter	Units	Influent	*Lead Reactor	*Lag Reactor	Aeration	Media Filter Effluent	Post Sodium Hypo	Finished Water	GAC 1 Effluent	GAC 2 Effluent	IX 1 Effluent	Permitted Outfall
pH	(std units)	7.67	7.58	7.48	7.89	7.82		7.89				7.70
Temperature	(°C)	18.6	19.6 20.6	20.5	20.3			18.6				18.8
ORP	(mV)	179	-428	-547	-237	30		59				
Dissolved Oxygen	(mg/L)	9.0	0.15	0.05	7.0	4.5		6.5				
Nitrate + Nitrite	(mg/L-N)	9.0	2.10	0				0.5				
Nitrite	(mg/L-N)	0	0.75	0				0				
Sulfide	(mg/L)	0	0	1.5	0.9			0				
Turbidity	(NTU)							0.44				
Chlorine Residual	(mg/L)							0*	0*			

* Signifies MIBR 1 or MIBR 2 depending on if reactor is in the lead or lag position - this changes every 96 hours

Note: shaded boxes are to remain blank

Treatment System Inspection		
Outlet Totalizer	gal	641800
Target Flow Rate	gpm	10
Internal Recycle Rate	gpm	180
MBfR 1 pH	std units	7.2
MBfR 2 pH	std units	7.2
MBfR 1 ORP	mV	-630
MBfR 2 ORP	mV	-90
Nitrate Frequency	Hz	240
Last N Feed	ppm (N)	7.99
Last N R1	ppm (N)	0
Last N R2	ppm (N)	2.24
MBfR1 Sparge Rate	mm	240
MBfR2 Sparge Rate	mm	240
Phosphate Pump Settings	spm	30
	% stroke	34
Phosphate Concentration at Strainer	mg/LPO4	1.5
Aeration Tank Air Flow	scfm	3.2
Air Tank Pressure	psig	2.0
Target Media Filter Flow Rate	gpm	9.0
Media Filter Inlet Pressure	psig	2.6
Media Filter Outlet Pressure	psig	1.5
Sodium Hypo Pump Settings	spm	20
	% stroke	100
Coagulant Tank Level	gal	5
Coagulant Pump Settings	gal/min	74
CO2 Cylinder Pressure	psi	90
H2 Cylinder Pressure	psi	90
N2 Pressure	psi	144
N2 Flow Rate	scfm	-

Post Finished Water System Inspection		
Collect while sump is running		
Bag Filter ΔP	psi	13
GAC-1 Pressure	psig	10
GAC-2 Pressure	psig	5
IX-1 Pressure	psig	0

Feed Tank Additions		
	H3PO4	Sodium Hypo
Time		
Initial Tank Level (gal)		
Stock Added		
Type of Water Used For Dilution		
Volume Dilution Added (gal)		
Total Volume Added (gal)		
Final Tank Level (gal)		

Note: There are 3785 mL per gallon.

Backwash Record		
Backwash start time:		
Backwash duration	min	
Initial Product Tank Level	gal	
Final Product Tank Level	gal	
Time of sample collection:		
Location	Turbidity (NTU)	TSS Collected?
Lead Purge 1		<input type="checkbox"/> Yes <input type="checkbox"/> No
Lead Purge 2		<input type="checkbox"/> Yes <input type="checkbox"/> No
Lag Purge 1		<input type="checkbox"/> Yes <input type="checkbox"/> No
Lag Purge 2		<input type="checkbox"/> Yes <input type="checkbox"/> No
Media Filter		<input type="checkbox"/> Yes <input type="checkbox"/> No

NOTES:
 APT ON SITE UPON ARRIVAL FILLING COAGULANT TANK.
 A SIGNIFICANT LEAK ON SODIUM HYPO PUMP FITTING CONNECTIONS; THERE IS A CRACK ON ONE OF THE DISCHARGE FITTINGS. EPOXY-ED FITTING AND ALLOWED TO DRY SEVERAL HOURS LATER - ATTEMPTED TO RESTART PUMP BUT IT CONTINUED TO LEAK. RICH W/APT IS ORDERING THE FITTING FOR THIS. REPLACED BAG FILTER WITH 100/50 BAGS.

SEE NOTES

Inventory	
Type	Check
H3PO4 Stock (gal)	
Sodium Hypo Stock (gal)	
Additional Field Test Kits Needed?	Dissolved Oxygen
	Nitrate + Nitrite
	Nitrite
	Sulfide
	Chlorine
	o-Phosphate

SEVERAL HOURS LATER - ATTEMPTED TO RESTART PUMP BUT IT CONTINUED TO LEAK. RICH W/APT IS ORDERING THE FITTING FOR THIS. REPLACED BAG FILTER WITH 100/50 BAGS.

NOTES CONT...

HIGH SUMP LEVEL TRIGGERED FROM RAIN. REMOVED WATER FROM SEC. CONTAINMENT AND DISCHARGED IT TO THE GROUND (RAIN WATER ONLY). ELEVATED THE "CDM" SECONDARY CONTAINMENT HIGH LEVEL SWITCH 2 INCHES.

Date: 10/7/11

Time: 9:00

Operator: ARUCAN

Field Samples

Calibration		pH calibration? <input checked="" type="checkbox"/> Yes <input type="checkbox"/> No		ORP calibration? <input checked="" type="checkbox"/> Yes <input type="checkbox"/> No		Turbidity calibration? <input checked="" type="checkbox"/> Yes <input type="checkbox"/> No						
Standards: <u>14</u> <input checked="" type="checkbox"/> <u>17</u> <input checked="" type="checkbox"/> <u>10</u> <input type="checkbox"/>		Temp (Deg C): <u>19.9</u>		Standards: <u>20</u> <input checked="" type="checkbox"/> <u>20</u> <input checked="" type="checkbox"/> <u>200</u> <input checked="" type="checkbox"/> <u>1000</u> <input type="checkbox"/> <u>4000</u>		Readings: 0.107: <u>0.301</u> 0.301: <u>0.491</u>						
Standard Reading: 4: <u>4.04</u> 7: <u>7.02</u> 10: <u>10.01</u>		Standard Reading: <u>200</u> <u>211</u>		Sample Collection Time: <u>11:00</u>								
Lead Reactor: <input checked="" type="checkbox"/> MfBR1 <input type="checkbox"/> MfBR2		Lag Sample <input checked="" type="checkbox"/> SP-100A <input type="checkbox"/> SP-100B		if MfBR1 in LEAD: SP-200B <input checked="" type="checkbox"/>		if MfBR2 in LEAD: SP-100B <input type="checkbox"/>						
Parameter	Units	Influent	*Lead Reactor	*Lag Reactor	Aeration	Media Filter Effluent	Post Sodium Hypo	Finished Water	GAC 1 Effluent	GAC 2 Effluent	IX 1 Effluent	Permitted Outfall
pH	(std units)	7.35	7.60	7.50	7.88	—	—	—	—	—	—	—
Temperature	(°C)	19.1	19.5	20.4	20.5	—	—	—	—	—	—	—
ORP	(mV)	135	-410	-530	-232	-140	—	90	—	—	—	—
Dissolved Oxygen	(mg/L)	9	0.2	0.05	5	6	—	7	—	—	—	—
Nitrate + Nitrite	(mg/L-N)	8.75	2.8	0.2	—	—	—	0.2	—	—	—	—
Nitrite	(mg/L-N)	0	0.75	0	—	—	—	0	—	—	—	—
Sulfide	(mg/L)	0	0	0.2	0.8	—	—	0	—	—	—	—
Turbidity	(NTU)	—	—	—	—	—	—	—	—	—	—	—
Chlorine Residual	(mg/L)	—	—	—	—	—	0.6	0.1	—	—	—	—

Treatment System Inspection		
Outlet Totalizer	gal	6446800
Target Flow Rate	gpm	10
Internal Recycle Rate	gpm	180
MBfR 1 pH	std units	7.2
MBfR 2 pH	std units	7.2
MBfR 1 ORP	mV	-224
MBfR 2 ORP	mV	-422
Nitrate Frequency	Hz	—
Last N Feed	ppm (N)	8.03
Last N R1	ppm (N)	1.81
Last N R2	ppm (N)	-0.02
MBfR1 Sparge Rate	mm	240
MBfR2 Sparge Rate	mm	240
Phosphate Pump Settings	spm	20
	% stroke	30
Phosphate Concentration at Strainer	mg/LPO4	42
Aeration Tank Air Flow	scfm	63.2
Air Tank Pressure	psig	2.1
Target Media Filter Flow Rate	gpm	9.0
Media Filter Inlet Pressure	psig	2.3
Media Filter Outlet Pressure	psig	1.5
Sodium Hypo Pump Settings	spm	OFF
	% stroke	—
Coagulant Tank Level	gal	1
Coagulant Pump Settings		2
CO2 Cylinder Pressure	psi	90
H2 Cylinder Pressure	psi	60
N2 Pressure	psi	142
N2 Flow Rate	scfm	—

* Signifies MBfR 1 or MBfR 2 depending on if reactor is in the lead or lag position - this changes every 96 hours

Note: shaded boxes are to remain blank

Post Finished Water System Inspection		
Collect while sump is running		
Bag Filter ΔP	psi	2
GAC-1 Pressure	psig	17
GAC-2 Pressure	psig	13
IX-1 Pressure	psig	2.5

Backwash Record		
Backwash start time: <u>12:00</u>		
Backwash duration	min	—
Initial Product Tank Level	gal	—
Final Product Tank Level	gal	—
Time of sample collection:		
Location	Turbidity (NTU)	TSS Collected?
Lead Purge 1	—	<input type="checkbox"/> Yes <input checked="" type="checkbox"/> No
Lead Purge 2	—	<input type="checkbox"/> Yes <input checked="" type="checkbox"/> No
Lag Purge 1	—	<input type="checkbox"/> Yes <input checked="" type="checkbox"/> No
Lag Purge 2	—	<input type="checkbox"/> Yes <input checked="" type="checkbox"/> No
Media Filter	—	<input type="checkbox"/> Yes <input checked="" type="checkbox"/> No

Inventory		
Type	Check	
H3PO4 Stock (gal)	4	
Sodium Hypo Stock (gal)	15	
Additional Field Test Kits Needed?	Dissolved Oxygen	<input checked="" type="checkbox"/>
	Nitrate + Nitrite	<input checked="" type="checkbox"/>
	Nitrite	<input checked="" type="checkbox"/>
	Sulfide	<input checked="" type="checkbox"/>
	Chlorine	<input checked="" type="checkbox"/>
	o-Phosphate	<input checked="" type="checkbox"/>

Feed Tank Additions		
	H3PO4	Sodium Hypo
Time	3:00	3:00
Initial Tank Level (gal)	2	6
Stock Added	250	8 GALLONS
Type of Water Used For Dilution	INF	FILTER
Volume Dilution Added (gal)	3.0	16
Total Volume Added (gal)	3.0	24
Final Tank Level (gal)	5.0	30

NOTES:
 APT ON-SITE TO VENT MOISTURE FOR GAS LINES. MAY AFFECT GAS PRESSURE READINGS. CDM TO COLLECT TURBIDITY SAMPLE AND SEND TO LAB. CDM & APT NOTE NOTICE WELL PVC PIPING HAS MOVED, THE WE HAVE ADDRESSED ISSUE BUT PLACING SANDBAGS.

ONLINE TURBIDITY
8.37

Note: There are 3785 mL per gallon.

NOTES CONT:

CDM CONDUCT GAS READINGS AT POINTS ONSITE.
 SUMMARY BELOW. CDM TO DISCUSS SAMPLE INSTALLATION
 ON TROUBLE TANK LINE TO THE Sump. APT HAS REDUCED
 FLOW TO 5 GPM. APT HAS REFILLED THE FILTER AID SOLUTION.
 CDM UNABLE TO CALIBRATE TURBIDITY METER

4-GAS METER READINGS

	4-GAS O	METHANE	CO	H ₂ S
CAL. TEST	12%	2.5 (50%)	50	25
PASS/FAIL	PASS	PASS	PASS	PASS
AERATION	20.9	0	135	4
TOP OF MBFR SKID	21.0	0	110	0
MEDIA FILTER	21.1	0	6	0
4-GAS CAL KIT	14	58	60	24

TURBIDITY w/ NO VIAL
0.174

Date: 10/10/11

Time: 9:15

Operator: ARUCIAN

Field Samples

Calibration	pH calibration? <input checked="" type="checkbox"/> Yes <input type="checkbox"/> No		ORP calibration? <input checked="" type="checkbox"/> Yes <input type="checkbox"/> No		Turbidity calibration? <input checked="" type="checkbox"/> Yes <input type="checkbox"/> No									
	Standards: <input checked="" type="checkbox"/> 4 <input checked="" type="checkbox"/> 7 <input checked="" type="checkbox"/> 10		Temp (Deg C): _____		Standards: <input type="checkbox"/> 0 <input type="checkbox"/> 20 <input type="checkbox"/> 200 <input checked="" type="checkbox"/> 1000 <input type="checkbox"/> 4000									
Standard Reading: 4: <u>4.02</u> 7: <u>7.08</u> 10: <u>10.11</u>		Standard Reading: <u>200</u> <u>218</u>		Readings: 0.107, <u>171</u> 0.301, <u>394</u> 0.491, <u>622</u>										
Lead Reactor: <input type="checkbox"/> MBR1 <input checked="" type="checkbox"/> MBR2		Lag Sample <input type="checkbox"/> if MBR1 in LEAD: SP-200B <input type="checkbox"/> if MBR2 in LEAD: SP-100A <input checked="" type="checkbox"/>		Sample Collection Time: <u>12:00</u>										
Sample Data	Parameter	Units	Influent	*Lead Reactor	*Lag Reactor	Aeration	Media Filter Effluent	Post Sodium Hypo	Finished Water	GAC 1 Effluent	GAC 2 Effluent	IX 1 Effluent	Permitted Outfall	
	pH	(std units)	7.42	7.59	7.52	8.01	7.91		7.89				7.52	
	Temperature	(°C)	19.9	21.5	21.5	22.0	21.8		21.2				21.3	
	ORP	(mV)	140											
	Dissolved Oxygen	(mg/L)	9	0.3	0.0	4	5		6.5					
	Nitrate + Nitrite	(mg/L-N)	8.7	2.2	0				0.2					
	Nitrite	(mg/L-N)	0	0.25	0				0					
	Sulfide	(mg/L)	0	0.5	3.5	4.0			0					
	Turbidity	(NTU)	0.295			2.67	1.59		1.26					
	Chlorine Residual	(mg/L)							>5	5				

* Signifies MBR 1 or MBR 2 depending on if reactor is in the lead or lag position - this changes every 96 hours

Note: shaded boxes are to remain blank

Treatment System Inspection		
Outlet Totalizer	gal	6470800
Target Flow Rate	gpm	5
Internal Recycle Rate	gpm	180
MBFR 1 pH	std units	7.1
MBFR 2 pH	std units	7.2
MBFR 1 ORP	mV	-638
MBFR 2 ORP	mV	-655
Nitrate Frequency	Hz	
Last N Feed	ppm (N)	8.13
Last N R1	ppm (N)	1.56
Last N R2	ppm (N)	0.03
MBFR1 Sparge Rate	mm	240
MBFR2 Sparge Rate	mm	240
Phosphate Pump Settings	spr	20
Phosphate Concentration at Strainer	% stroke	30
Aeration Tank Air Flow	scfm	3.4
Air Tank Pressure	psig	2.0
Target Media Filter Flow Rate	gpm	4.5
Media Filter Inlet Pressure	psig	2.7
Media Filter Outlet Pressure	psig	1.3
Sodium Hypo Pump Settings	spr	30
	% stroke	100
Coagulant Tank Level	gal	0
Coagulant Pump Settings	m/min	2
CO2 Cylinder Pressure	psi	89
H2 Cylinder Pressure	psi	91
N2 Pressure	psi	184
N2 Flow Rate	scfm	

Post Finished Water System Inspection		
Collect while sump is running		
Bag Filter ΔP	psi	2
GAC-1 Pressure	psig	16
GAC-2 Pressure	psig	13
IX-1 Pressure	psig	3

Feed Tank Additions		
	H3PO4	Sodium Hypo
Time	9:30	9:30
Initial Tank Level (gal)	3	25
Stock Added	0	0
Type of Water Used For Dilution	INF	0
Volume Dilution Added (gal)	2	0
Total Volume Added (gal)	5	0
Final Tank Level (gal)	5	25

Note: There are 3785 mL per gallon.

Backwash Record		
Backwash start time: _____		
Backwash duration	min	
Initial Product Tank Level	gal	
Final Product Tank Level	gal	
Time of sample collection: _____		
Location	Turbidity (NTU)	TSS Collected?
Lead Purge 1		<input type="checkbox"/> Yes <input type="checkbox"/> No
Lead Purge 2		<input type="checkbox"/> Yes <input type="checkbox"/> No
Lag Purge 1		<input type="checkbox"/> Yes <input type="checkbox"/> No
Lag Purge 2		<input type="checkbox"/> Yes <input type="checkbox"/> No
Media Filter		<input type="checkbox"/> Yes <input type="checkbox"/> No

NOTES:
 CDM NOTICED FILTER AND TANK IS EMPTY, ALERTED
 APT AND SHUT-OFF TANK - CDM UNABLE TO TAKE
 ORP AT LOCATIONS, PROBE NEEDS TO BE REPLACED.
 CDM HAS MEASURED GAS, READINGS ON BACK

Inventory		
Type	Check	
H3PO4 Stock (gal)	4	
Sodium Hypo Stock (gal)	10 GAL	
Additional Field Test Kits Needed?	Dissolved Oxygen	<input checked="" type="checkbox"/>
	Nitrate + Nitrite	<input checked="" type="checkbox"/>
	Nitrite	<input checked="" type="checkbox"/>
	Sulfide	<input checked="" type="checkbox"/>
	Chlorine	<input checked="" type="checkbox"/>
	o-Phosphate	<input checked="" type="checkbox"/>

Chlorine 5
 @ Sump
 TURBIDITY 1.87

	O	CO	LEV	H ₂ S
AERATION (CLOSE LID)	21.4	143	0	2
AERATION (OPEN LID)	21.0	119	0	1

NOTES :

CDM CHANGED CHLORINE INJECTION PUMP SETTINGS TO 20 STROKES PER MIN W/ 100 % STROKE LENGTH. THE CHANGE WAS MADE DUE TO HIGH CHLORINE RESIDUAL IN THE PRODUCT TANK.

Date: 10/14/11

Time: 9AM

Operator: BEROKOFF

Field Samples

Calibration	pH calibration? <input checked="" type="checkbox"/> Yes <input type="checkbox"/> No NEED MORE BUFFERS!	ORP calibration? <input type="checkbox"/> Yes <input checked="" type="checkbox"/> No	Turbidity calibration? <input checked="" type="checkbox"/> Yes <input type="checkbox"/> No										
	Standards: <input checked="" type="checkbox"/> 4 <input checked="" type="checkbox"/> 7 <input type="checkbox"/> 10	Temp (Deg C): <u>-</u>	Standards: <input type="checkbox"/> 0 <input type="checkbox"/> 20 <input type="checkbox"/> 200 <input type="checkbox"/> 1000 <input type="checkbox"/> 4000										
	Standard Reading: 4: <u>4.01</u> 7: <u>7.02</u> 10: <u>-</u>	Standard Reading: 200: <u>-</u>	Readings: 0.107: <u>-</u> 0.301: <u>-</u> 0.491: <u>-</u>										
Lead Sample <input type="checkbox"/> Lag Sample <input type="checkbox"/> Lead Reactor: <input type="checkbox"/> MBR1 <input checked="" type="checkbox"/> MBR2 if MBR1 in LEAD: SP-200B <input type="checkbox"/> if MBR2 in LEAD: SP-100A <input type="checkbox"/> if MBR2 in LEAD: SP-100B <input checked="" type="checkbox"/>													
Sample Collection Time: <u>10:30</u>													
Sample Data	Parameter	Units	Influent	*Lead Reactor	*Lag Reactor	Aeration	Media Filter Effluent	Post Sodium Hypo	Finished Water	GAC 1 Effluent	GAC 2 Effluent	IX 1 Effluent	Permitted Outfall
	pH	(std units)	7.60	7.20	7.52	8.06	7.88		7.91				7.48
	Temperature	(°C)	20.0	22.5	24.0	23.9	24.2		24.3				24.1
	ORP	(mV)	-	-	-	-	-		-				-
	Dissolved Oxygen	(mg/L)	9	0.25	0.05	7.0	0.05		1.0				
	Nitrate + Nitrite	(mg/L-N)	8	0.4	0				0				
	Nitrite	(mg/L-N)	0	0.2	0				0				
	Sulfide	(mg/L)	0	0	6	4			0				
	Turbidity	(NTU)	-						8.58				
	Chlorine Residual	(mg/L)							2.5	0.4			

* Signifies MBR1 or MBR2 depending on if reactor is in the lead or lag position - this changes every 96 hours

Note: shaded boxes are to remain blank

Treatment System Inspection

Outlet Totalizer	gal	6498800
Target Flow Rate	gpm	5
Internal Recycle Rate	gpm	180
MBfR 1 pH	std units	7.2
MBfR 2 pH	std units	7.2
MBfR 1 ORP	mV	-440
MBfR 2 ORP	mV	-240
Nitrate Frequency	Hz	-
Last N Feed	ppm (N)	8.17
Last N R1	ppm (N)	1.26
Last N R2	ppm (N)	0.05
MBfR1 Sparge Rate	mm	240
MBfR2 Sparge Rate	mm	240
Phosphate Pump Settings	spm	30
	% stroke	30
Phosphate Concentration at Strainer	mg/LPO4	1.5
Aeration Tank Air Flow	scfm	3.4
Air Tank Pressure	psig	2.0
Target Media Filter Flow Rate	gpm	4
Media Filter Inlet Pressure	psig	3.5
Media Filter Outlet Pressure	psig	1.3
Sodium Hypo Pump Settings	spm	30
	% stroke	100
Coagulant Tank Level	gal	2.0
Coagulant Pump Settings		OFF
CO2 Cylinder Pressure	psi	88
H2 Cylinder Pressure	psi	90
N2 Pressure	psi	153
N2 Flow Rate	scfm	-

Post Finished Water System Inspection

Collect while sump is running		
Bag Filter ΔP	psi	2
GAC-1 Pressure	psig	14
GAC-2 Pressure	psig	9.5
IX-1 Pressure	psig	1.2

Feed Tank Additions

	H3PO4	Sodium Hypo
Time	2:30	12:15
Initial Tank Level (gal)	3	18
Stock Added	50	-
Type of Water Used For Dilution	INF	-
Volume Dilution Added (gal)	2	-
Total Volume Added (gal)	2	-
Final Tank Level (gal)	5	18

Note: There are 3785 mL per gallon.

Backwash Record

Backwash start time:		
Backwash duration	min	
Initial Product Tank Level	gal	
Final Product Tank Level	gal	
Time of sample collection:		
Location	Turbidity (NTU)	TSS Collected?
Lead Purge 1		<input type="checkbox"/> Yes <input type="checkbox"/> No
Lead Purge 2		<input type="checkbox"/> Yes <input type="checkbox"/> No
Lag Purge 1		<input type="checkbox"/> Yes <input type="checkbox"/> No
Lag Purge 2		<input type="checkbox"/> Yes <input type="checkbox"/> No
Media Filter		<input type="checkbox"/> Yes <input type="checkbox"/> No

Inventory

	Type	Check
H3PO4 Stock (gal)		<input checked="" type="checkbox"/>
Sodium Hypo Stock (gal)		<input checked="" type="checkbox"/>
Additional Field Test Kits Needed?	Dissolved Oxygen	<input checked="" type="checkbox"/>
	Nitrate + Nitrite	<input checked="" type="checkbox"/>
	Nitrite	<input checked="" type="checkbox"/>
	Sulfide	<input checked="" type="checkbox"/>
	Chlorine	<input checked="" type="checkbox"/>
	o-Phosphate	<input checked="" type="checkbox"/>

NOTES:

SODIUM HYPO TANK WAS LEFT UNCOVERED EXPOSING IT TO LIGHT. USM COVERED W/BLACK TRASH BAG AND SECURED IT TO TANK. INCREASED SPM ON PUMP (CL2) TO 40SPM FROM 30. THIS ELEVATED POST MEDIA FILTER CL2 CONCENTRATION TO 4.5PPM.

NOTES CONT. 11

USED SILICON SOLUTION TO PREP SAMPLE VIALS DURING TURBIDIMETER CALIBRATION AND DURING SAMPLE ANALYSIS. ACCORDING TO THE VALUES IN BELOW TABLE, ~~EVER~~ THE < 0.1 NTU STANDARD DID NOT READ PROPERLY BY DISPLAYING A VALUE NEAR 0.4 NTU. NEW SAMPLE VIALS WERE USED DURING TODAY'S ANALYSIS.

TURBIDIMETER IS WAY OFF \rightarrow READING 8.6 ON PRODUCT WATER. THIS INSTRUMENT REQUIRES A FACTORY "TUNE UP".

TURBIDITY STANDARDS - POST CALIBRATION

4000 NTU \rightarrow 3999
1000 NTU \rightarrow ~~996~~ 997
200 NTU \rightarrow 200
20 NTU \rightarrow 20.6
 < 0.1 NTU \rightarrow 0.394

Date: 10/17/11

Time: 9AM

Operator: BEROKOFF

Field Samples													
Calibration	pH calibration? <input checked="" type="checkbox"/> Yes <input type="checkbox"/> No			ORP calibration? <input type="checkbox"/> Yes <input checked="" type="checkbox"/> No			Turbidity calibration? <input checked="" type="checkbox"/> Yes <input type="checkbox"/> No			Standards: <input type="checkbox"/> 0 <input type="checkbox"/> 20 <input type="checkbox"/> 200 <input type="checkbox"/> 1000 <input type="checkbox"/> 4000			
	Standards: <input checked="" type="checkbox"/> 4 <input checked="" type="checkbox"/> 7 <input type="checkbox"/> 10			Temp (Deg C): _____			Standard Reading: 200: <u>NEW PROBE</u>			Readings: 0.107: _____ 0.301: _____ 0.491: _____			
Sample Data	Lead Sample <input type="checkbox"/> Lag Sample <input type="checkbox"/>		Lead Reactor: <input type="checkbox"/> MBfR1 <input checked="" type="checkbox"/> MBfR2		if MBfR1 in LEAD: SP-200B <input type="checkbox"/> if MBfR2 in LEAD: SP-100B <input checked="" type="checkbox"/>		Sample Collection Time: <u>10AM</u>						
	Parameter	Units	Influent	*Lead Reactor	*Lag Reactor	Aeration	Media Filter Effluent	Post Sodium Hypo	Finished Water	GAC 1 Effluent	GAC 2 Effluent	IX 1 Effluent	Permitted Outfall
	pH	(std units)	7.57	7.16	7.59	7.94	7.76		7.77				7.88
	Temperature	(°C)	19.3	21.1	21.8	21.7	21.8		22				22
	ORP	(mV)	-	-	-	-	-		-				-
	Dissolved Oxygen	(mg/L)	9.0	0.4	0.1	7.0	4.5		5.5				
	Nitrate + Nitrite	(mg/L-N)	10	7.5	0.7				0.6				
	Nitrite	(mg/L-N)	0	1.8	0.4				0				
	Sulfide	(mg/L)	0	0	0	0			0				
	Turbidity	(NTU)	0.29			2.99	1.50		0.85				
	Chlorine Residual	(mg/L)							2.0	1.25			

* Signifies MBfR 1 or MBfR 2 depending on if reactor is in the lead or lag position - this changes every 96 hours

Note: shaded boxes are to remain blank

Post Finished Water System Inspection		
Collect while sump is running		
Bag Filter ΔP	psi	2
GAC-1 Pressure	psig	14
GAC-2 Pressure	psig	10
IX-1 Pressure	psig	1.4

Backwash Record		
Backwash start time: <u>12:30</u>		
Backwash duration	min	
Initial Product Tank Level	gal	
Final Product Tank Level	gal	
Time of sample collection:		
Location	Turbidity (NTU)	TSS Collected?
Lead Purge 1	-	<input type="checkbox"/> Yes <input type="checkbox"/> No
Lead Purge 2	-	<input type="checkbox"/> Yes <input type="checkbox"/> No
Lag Purge 1	-	<input type="checkbox"/> Yes <input type="checkbox"/> No
Lag Purge 2	-	<input type="checkbox"/> Yes <input type="checkbox"/> No
Media Filter	<u>27.4</u>	<input checked="" type="checkbox"/> Yes <input type="checkbox"/> No

Inventory		
Type	Check	
H3PO4 Stock (gal)	<u>9</u>	
Sodium Hypo Stock (gal)	<u>16</u>	
Additional Field Test Kits Needed?	Dissolved Oxygen	<u>11/4</u>
	Nitrate + Nitrite	<u>8</u>
	Nitrite	<u>8</u>
	Sulfide	<u>4</u>
	Chlorine	<u>5</u>
	o-Phosphate	<u>3</u>

Feed Tank Additions		
	H3PO4	Sodium Hypo
Time	<u>1:40</u>	<u>2:00</u>
Initial Tank Level (gal)	<u>2.7</u>	<u>8</u>
Stock Added 275	<u>275</u>	<u>7 gal</u>
Type of Water Used For Dilution	<u>INF</u>	<u>MEDIA FILTER</u>
Volume Dilution Added (gal)	<u>2.3</u>	<u>15</u>
Total Volume Added (gal)	<u>2.3</u>	<u>22</u>
Final Tank Level (gal)	<u>5</u>	<u>30</u>

Note: There are 3785 mL per gallon.

NOTES:
 REACTOR 1 HAS TWO MODULES OFFLINE, REACTOR 2 HAS ONE MODULE OFFLINE (APT INDICATED THAT ONE OF THE R1 MODULES FAILED OVER THE WEEKEND SO THEY SHUT IT DOWN. SENDING TURBIDIMETER IN FOR FACTORY SERVICE. USED 2100P MODEL INSTEAD.

Treatment System Inspection		
Outlet Totalizer	gal	<u>6539000</u>
Target Flow Rate	gpm	<u>10</u>
Internal Recycle Rate	gpm	<u>150/180</u>
MBfR 1 pH	std units	<u>7.2</u>
MBfR 2 pH	std units	<u>7.2</u>
MBfR 1 ORP	mV	<u>-393</u>
MBfR 2 ORP	mV	<u>-22</u>
Nitrate Frequency	Hz	<u>-</u>
Last N Feed	ppm (N)	<u>8.08</u>
Last N R1	ppm (N)	<u>0.26</u>
Last N R2	ppm (N)	<u>5.5</u>
MBfR1 Sparge Rate	mm	<u>240</u>
MBfR2 Sparge Rate	mm	<u>240</u>
Phosphate Pump Settings	spm	<u>20</u>
	% stroke	<u>30</u>
Phosphate Concentration at Strainer	mg/LPO4	
Aeration Tank Air Flow	scfm	<u>3.2</u>
Air Tank Pressure	psig	<u>2.2</u>
Target Media Filter Flow Rate	gpm	<u>4</u>
Media Filter Inlet Pressure	psig	<u>8.0</u>
Media Filter Outlet Pressure	psig	<u>1.3</u>
Sodium Hypo Pump Settings	spm	<u>30</u>
	% stroke	<u>100</u>
Coagulant Tank Level	gal	<u>2</u>
Coagulant Pump Settings		<u>OFF</u>
CO2 Cylinder Pressure	psi	<u>87</u>
H2 Cylinder Pressure	psi	<u>88</u>
N2 Pressure	psi	<u>141</u>
N2 Flow Rate	scfm	<u>-</u>

NOTES CONT...

UPON TOPPING OFF CHLORINE TANK, REDUCED SPM ON PUMP TO 30SPM (FROM 40). COVERED TANK AFTER FILLING.

60854 7MSLT

TURBIDITY BACKCHECK (POST CALIBRATION)

STANDARD	READING (NTU)
< 0.1	0.06
20	20.0
100	99.3
800	> 100

Date: 10/19/11

Time: 9:00

Operator: ARUCAN

Field Samples

Calibration
 pH calibration? Yes No
 Standards: 4 7 10
 Standard Reading: 4: _____ 7: _____ 10: _____
 ORP calibration? Yes No
 Temp (Deg C): _____
 Standard Reading: ~~200~~ 248
 Turbidity calibration? Yes No
 Standards: 0 20 200 1000 4000
 Readings: 0.107: _____ 0.301: _____ 0.491: _____

Lead Sample Lag Sample
 Lead Reactor: MIBR1 MIBR2
 if MIBR1 in LEAD: SP-200B
 if MIBR2 in LEAD: SP-100A SP-100B
 Sample Collection Time: 11:00

Parameter	Units	Influent	*Lead Reactor	*Lag Reactor	Aeration	Media Filter Effluent	Post Sodium Hypo	Finished Water	GAC 1 Effluent	GAC 2 Effluent	IX 1 Effluent	Permitted Outfall
pH	(std units)	7.28	7.27	7.52	7.86	7.77		7.79				7.67
Temperature	(°C)	18.9	20.9	21.1	21.6	21.6		21.3				21.1
ORP	(mV)	171*	20*	—	—	—		—				—
Dissolved Oxygen	(mg/L)	8	0.3	0.1	5	6		7				—
Nitrate + Nitrite	(mg/L-N)	8.5	2.8	0				0.2				—
Nitrite	(mg/L-N)	0	0.25	0				0				—
Sulfide	(mg/L)	0	0	0.4	0.1			0				—
Turbidity	(NTU)	0.35			2.5	0.9		0.8				—
Chlorine Residual	(mg/L)						1.0	0.4				—

* Signifies MBFR 1 or MBFR 2 depending on if reactor is in the lead or lag position - this changes every 96 hours

Notes: shaded boxes are to remain blank

Treatment System Inspection

Outlet Totalizer	gal	6567400
Target Flow Rate	gpm	10
Internal Recycle Rate	gpm	180 (ON BOTH)
MBFR 1 pH	std units	7.2
MBFR 2 pH	std units	7.2
MBFR 1 ORP	mV	-395
MBFR 2 ORP	mV	-47
Nitrate Frequency	Hz	—
Last N Feed	ppm (N)	8.08
Last N R1	ppm (N)	8.02 0.02
Last N R2	ppm (N)	2.02 3.07
MBFR1 Sparge Rate	mm	200
MBFR2 Sparge Rate	mm	240
Phosphate Pump Settings	spm	20
	% stroke	30
Phosphate Concentration at Strainer	mg/LPO4	3.2
Aeration Tank Air Flow	scfm	2.0 3.2
Air Tank Pressure	psig	2.0
Target Media Filter Flow Rate	gpm	9.0
Media Filter Inlet Pressure	psig	1.6
Media Filter Outlet Pressure	psig	1.5
Sodium Hypo Pump Settings	spm	30
	% stroke	100
Coagulant Tank Level	gal	3
Coagulant Pump Settings	ml/min	30
CO2 Cylinder Pressure	psi	88
H2 Cylinder Pressure	psi	91
N2 Pressure	psi	149
N2 Flow Rate	scfm	

Post Finished Water System Inspection

Collect while sump is running

Bag Filter ΔP	psi	2
GAC-1 Pressure	psig	20.5
GAC-2 Pressure	psig	14
IX-1 Pressure	psig	1.5

Feed Tank Additions

	H3PO4	Sodium Hypo
Time	9:30	9:30
Initial Tank Level (gal)	3.5	2.5
Stock Added	0	0
Type of Water Used For Dilution	NA	NA
Volume Dilution Added (gal)	0	0
Total Volume Added (gal)	0	0
Final Tank Level (gal)	3.5	2.5

Note: There are 3785 mL per gallon.

Backwash Record

Backwash start time: _____

Backwash duration	min	
Initial Product Tank Level	gal	
Final Product Tank Level	gal	

Time of sample collection: _____

Location	Turbidity (NTU)	TSS Collected?
Lead Purge 1		<input type="checkbox"/> Yes <input type="checkbox"/> No
Lead Purge 2		<input type="checkbox"/> Yes <input type="checkbox"/> No
Lag Purge 1		<input type="checkbox"/> Yes <input type="checkbox"/> No
Lag Purge 2		<input type="checkbox"/> Yes <input type="checkbox"/> No
Media Filter		<input type="checkbox"/> Yes <input type="checkbox"/> No

Inventory

Type	Check	
H3PO4 Stock (gal)	4	
Sodium Hypo Stock (gal)	15	
Additional Field Test Kits Needed?	Dissolved Oxygen	15
	Nitrate + Nitrite	8
	Nitrite	8
	Sulfide	4
	Chlorine	5
	o-Phosphate	3

NOTES:
 APT ONSITE TO DRAIN FIBERS ON MBFR 2. APT ALSO REFILL FILTER AID. APT EXPLAINED THAT N2 IS NO LONGER USED IN SPARGE & AIR COMPRESSOR WAS INSTALLED IN-LINE. APT ALSO EXPLAINED THAT

TURBIDITY (OIT) PRODUCT TANK 0.60

TURBIDITY (OIT) 0.56 (BOUNCES)
 TURBIDITY (INST) 0.21 (STEADY)

NOTES CONT:

APT WAS ABLE TO REPAIR THE "LEAKY" MODULE FROM MBFR 1. THE FAILURE WAS NOT DUE TO EPOXY, IT WAS FOUND THAT THE TOP NUT WAS LOOSE. APT REAPPLIED O-RING AND TIGHTENED THE TOP NUT. CDM & APT OBSERVED THAT SITE DOES HAVE LESS PUNGENT (H₂S) SMELL. *OPP PROBE NOT READING CORRECTLY. AT 12:30, APT SHUT DOWN FILTER AID. INITIAL TURBIDITY READING ON @ IN-LINE PROBE = 0.29.

@ 1:30 TURBIDITY = 0.66. CDM MONITORED 4 GASES (O₂, H₂S, CO, LEL) RESULTS ARE AS FOLLOWS:

	CAL. BOTTLE	EAL. PASS?	AGITATION TANK	OIT
O ₂	12%	P	20.1	20.2
CO	50 ppm	P	6/3	2
LEL	50%	P	0/0	0
H ₂ S	25 ppm	P	0/0	0

@ 1:45 APT HAS DECIDED TO TRY A NEW FILTER AID. READINGS WILL BE RELAYED FROM APT. @ 2:00 APT REFS AND DAVID TRESE ONSITE TO TAKE TOUR OF TREATMENT PLANT.

Date: 10/21/11

Time: 9:00AM

Operator: BERONOFF

Field Samples

Calibration	pH calibration? <input checked="" type="checkbox"/> Yes <input type="checkbox"/> No		ORP calibration? <input type="checkbox"/> Yes <input checked="" type="checkbox"/> No		Turbidity calibration? <input checked="" type="checkbox"/> Yes <input type="checkbox"/> No								
	Standards: <input checked="" type="checkbox"/> 4 <input checked="" type="checkbox"/> 7 <input type="checkbox"/> 10		Temp (Deg C): _____		Standards: <input type="checkbox"/> 0 <input checked="" type="checkbox"/> 20 <input checked="" type="checkbox"/> 100 <input checked="" type="checkbox"/> 200 <input type="checkbox"/> 4000								
Standard Reading: 4: <u>4.00</u> 7: <u>6.98</u> 10: <u>-</u>		Standard Reading: 200: _____		Readings: 0.107: _____ 0.301: _____ 0.491: _____									
Sample Data	Lead Sample <u> </u> Lag Sample <u> </u>		Lead Reactor: <input type="checkbox"/> MIBR1 <input checked="" type="checkbox"/> MIBR2		if MBFR1 in LEAD: SP-200B <input type="checkbox"/> SP-100A <input type="checkbox"/> if MBFR2 in LEAD: SP-100B <input checked="" type="checkbox"/>								
	Sample Collection Time: <u>10:00</u>												
	Parameter	Units	Influent	*Lead Reactor	*Lag Reactor	Aeration	Media Filter Effluent	Post Sodium Hypo	Finished Water	GAC 1 Effluent	GAC 2 Effluent	IX 1 Effluent	Permitted Outfall
	pH	(std units)	7.57	7.23	7.58	7.93	7.83		7.85				7.66
	Temperature	(°C)	18.8	20.4	21.3	21.2	21.1		20.5				20.5
	ORP	(mV)	-	-	-	-	-		-				
	Dissolved Oxygen	(mg/L)	9	0.5	0.1	7	5.5		7				
	Nitrate + Nitrite	(mg/L-N)	9	7 7	0.6				0.6				
	Nitrite	(mg/L-N)	0	2.0	0.4				0				
	Sulfide	(mg/L)	0	0	0.1	0			0				
	Turbidity	(NTU)	0.24			3.01	1.66		0.94				
	Chlorine Residual	(mg/L)						1.0	0.3				

* Signifies MBFR 1 or MBFR 2 depending on if reactor is in the lead or lag position - this changes every 96 hours

Note: shaded boxes are to remain blank

Post Finished Water System Inspection

Collect while sump is running

Bag Filter ΔP	psi	2
GAC-1 Pressure	psig	15
GAC-2 Pressure	psig	11
IX-1 Pressure	psig	1.1

Feed Tank Additions

	H3PO4	Sodium Hypo
Time	1:00	10:30
Initial Tank Level (gal)	2	20
Stock Added	240 mL	-
Type of Water Used For Dilution	INF	-
Volume Dilution Added (gal)	3	-
Total Volume Added (gal)	3	-
Final Tank Level (gal)	5	20

Note: There are 3785 mL per gallon.

Backwash Record

Backwash start time: <u>11:59AM</u>		
Backwash duration	min	~40
Initial Product Tank Level	gal	-
Final Product Tank Level	gal	-
Time of sample collection: <u>11:59AM-12:28PM</u>		
Location	Turbidity (NTU)	TSS Collected?
Lead Purge 1	3.39	<input checked="" type="checkbox"/> Yes <input type="checkbox"/> No
Lead Purge 2	5.14	<input checked="" type="checkbox"/> Yes <input type="checkbox"/> No
Lag Purge 1	83.4	<input checked="" type="checkbox"/> Yes <input type="checkbox"/> No
Lag Purge 2	37.9	<input checked="" type="checkbox"/> Yes <input type="checkbox"/> No
Media Filter	-	<input type="checkbox"/> Yes <input checked="" type="checkbox"/> No

NOTES:

COAGULANT TANK WAS EMPTY UPON ARRIVAL. CDM TURNED OFF COAGULANT METERING PUMP. INCREASED SODIUM HYPO PUMP SETTINGS TO 40SPM (FROM 30SPM) TO OBTAIN POST SODIUM HYPO INJECTION CL2 = 0.15PPM.

Inventory

Type	Check	
H3PO4 Stock (gal)	8	
Sodium Hypo Stock (gal)	15	
Additional Field Test Kits Needed?	Dissolved Oxygen	15
	Nitrate + Nitrite	7
	Nitrite	7
	Sulfide	4
	Chlorine	5
	o-Phosphate	3

Treatment System Inspection

Outlet Totalizer	gal	6596100
Target Flow Rate	gpm	10
Internal Recycle Rate	gpm	180
MBFR 1 pH	std units	7.2
MBFR 2 pH	std units	7.2
MBFR 1 ORP	mV	-444
MBFR 2 ORP	mV	23
Nitrate Frequency	Hz	-
Last N Feed	ppm (N)	8.09
Last N R1	ppm (N)	0.23
Last N R2	ppm (N)	6.17 6.17
MBFR1 Sparge Rate	mm	240
MBFR2 Sparge Rate	mm	240
Phosphate Pump Settings	spm	20
	% stroke	30
Phosphate Concentration at Strainer	mg/LPO4	
Aeration Tank Air Flow	scfm	3.2
Air Tank Pressure	psig	2.0
Target Media Filter Flow Rate	gpm	9
Media Filter Inlet Pressure	psig	4.7
Media Filter Outlet Pressure	psig	1.5
Sodium Hypo Pump Settings	spm	30
	% stroke	100
Coagulant Tank Level	gal	0
Coagulant Pump Settings	ML/min	17
CO2 Cylinder Pressure	psi	87
H2 Cylinder Pressure	psi	89
N2 Pressure	psi	142
N2 Flow Rate	scfm	-

MEDIA FILTER TURBIDITY (NTU) = 0.41 @ 10AM
 PRODUCT TANK (NTU) = 0.51 @ 10AM

NOTES CONT.

TOOK 4-GAS READINGS TODAY. ALL GAS LEVELS ~~WERE~~ ^{READ} ZERO EXCEPT O₂ (20.9).
TOOK TSS AND TURBIDITY SAMPLES ON MBFR SPARGE,

2100P

TURBIDIMETER	STANDARDS BEFORE CALIBRATION	BEFORE CALIBRATION	POST CALIBRATION
	< 0.1	0.08	0.07
	20	20.1	19.9
	100	99.5	99.3
	800	787	799

Date: 10/26/11

Time: 8:45

Operator: BEROKOFF

Field Samples

Calibration	pH calibration? <input checked="" type="checkbox"/> Yes <input type="checkbox"/> No		ORP calibration? <input checked="" type="checkbox"/> Yes <input type="checkbox"/> No		Turbidity calibration? <input checked="" type="checkbox"/> Yes <input type="checkbox"/> No								
	Standards: <input checked="" type="checkbox"/> 4 <input checked="" type="checkbox"/> 7 <input checked="" type="checkbox"/> 10		Temp (Deg C):		Standards: <input type="checkbox"/> 0 <input type="checkbox"/> 20 <input type="checkbox"/> 200 <input type="checkbox"/> 1000 <input type="checkbox"/> 4000								
Standard Reading: 4: <u>4.00</u> 7: <u>7.02</u> 10: <u>10.09</u>		Standard Reading: 200: <u>220</u>		Readings: 0.107: _____ 0.301: _____ 0.491: _____									
Lead Sample <input type="checkbox"/> Lag Sample <input type="checkbox"/> Lead Reactor: <input type="checkbox"/> MBFR1 <input checked="" type="checkbox"/> MBFR2 <input type="checkbox"/> SP-100A <input type="checkbox"/> if MBFR1 in LEAD: SP-200B <input type="checkbox"/> <input checked="" type="checkbox"/> if MBFR2 in LEAD: SP-100B <input type="checkbox"/> Sample Collection Time: <u>9:30 AM</u>													
Sample Data	Parameter	Units	Influent	*Lead Reactor	*Lag Reactor	Aeration	Media Filter Effluent	Post Sodium Hypo	Finished Water	GAC 1 Effluent	GAC 2 Effluent	IX 1 Effluent	Permitted Outfall
	pH	(std units)	7.63	7.32	7.03	7.98	7.80		7.86				7.73
	Temperature	(°C)	18.9	20.4	21.2	21.1	21.0		20.3				19.0
	ORP	(mV)	95	-398	-453	-215	30		659				
	Dissolved Oxygen	(mg/L)	9.0	0.15	0.10	7.0	4.0		5.5				
	Nitrate + Nitrite	(mg/L-N)	9.0	5.25	0.3				0.4				
	Nitrite	(mg/L-N)	0	2.0	0.1				0				
	Sulfide	(mg/L)	0	0	0.7	0.4			0				
	Turbidity	(NTU)	0.15			1.78	0.36		0.38				
	Chlorine Residual	(mg/L)							1.75	1.5			

* Signifies MBFR 1 or MBFR 2 depending on if reactor is in the lead or lag position - this changes every 96 hours

Note: shaded boxes are to remain blank

Treatment System Inspection

Outlet Totalizer	gal	6666600
Target Flow Rate	gpm	10
Internal Recycle Rate	gpm	180
MBFR 1 pH	std units	7.2
MBFR 2 pH	std units	7.2
MBFR 1 ORP	mV	-410
MBFR 2 ORP	mV	-208
Nitrate Frequency	Hz	-
Last N Feed	ppm (N)	8.10
Last N R1	ppm (N)	0.16
Last N R2	ppm (N)	2.63
MBFR1 Sparge Rate	mm	240
MBFR2 Sparge Rate	mm	240
Phosphate Pump Settings	spm	20
	% stroke	30
Phosphate Concentration at Strainer	mg/LPO4	1.7
Aeration Tank Air Flow	scfm	3.2
Air Tank Pressure	psig	2.0
Target Media Filter Flow Rate	gpm	9.5
Media Filter Inlet Pressure	psig	9.0
Media Filter Outlet Pressure	psig	1.5
Sodium Hypo Pump Settings	spm	40
	% stroke	100
Coagulant Tank Level	gal	0
Coagulant Pump Settings		0
CO2 Cylinder Pressure	psi	88
H2 Cylinder Pressure	psi	88
N2 Pressure	psi	147
N2 Flow Rate	scfm	-

Post Finished Water System Inspection

Collect while sump is running

Bag Filter ΔP	psi	2
GAC-1 Pressure	psig	15
GAC-2 Pressure	psig	10.5
IX-1 Pressure	psig	1.0

Feed Tank Additions

	H3PO4	Sodium Hypo
Time	2:00	9:00 AM
Initial Tank Level (gal)	1.3	7
Stock Added	300ml	0
Type of Water Used For Dilution	INF	-
Volume Dilution Added (gal)	3.7	-
Total Volume Added (gal)	3.7	-
Final Tank Level (gal)	5.0	7

Note: There are 3785 mL per gallon.

Backwash Record

Backwash start time:		
Backwash duration	min	
Initial Product Tank Level	gal	
Final Product Tank Level	gal	
Time of sample collection:		
Location	Turbidity (NTU)	TSS Collected?
Lead Purge 1		<input type="checkbox"/> Yes <input type="checkbox"/> No
Lead Purge 2		<input type="checkbox"/> Yes <input type="checkbox"/> No
Lag Purge 1		<input type="checkbox"/> Yes <input type="checkbox"/> No
Lag Purge 2		<input type="checkbox"/> Yes <input type="checkbox"/> No
Media Filter		<input type="checkbox"/> Yes <input type="checkbox"/> No

NOTES:

TOOK WEEKLY SAMPLES, MONTHLY INFLUENCE COMPLIANCE SAMPLES, AND DUPLICATES.

Inventory

Type	Check	
H3PO4 Stock (gal)	8	
Sodium Hypo Stock (gal)	15	
Additional Field Test Kits Needed?	Dissolved Oxygen	15
	Nitrate + Nitrite	7
	Nitrite	7
	Sulfide	4
	Chlorine	5
	o-Phosphate	3

Date: 10/31/11

Time: 9:30AM

Operator: BEROKOFF

Field Samples															
Calibration	pH calibration? <input checked="" type="checkbox"/> Yes <input type="checkbox"/> No Standards: <input checked="" type="checkbox"/> 4 <input checked="" type="checkbox"/> 7 <input checked="" type="checkbox"/> 10			ORP calibration? <input checked="" type="checkbox"/> Yes <input type="checkbox"/> No Temp (Deg C): <u>-</u>			Turbidity calibration? <input checked="" type="checkbox"/> Yes <input type="checkbox"/> No Standards: <input type="checkbox"/> 0 <input type="checkbox"/> 20 <input type="checkbox"/> 200 <input type="checkbox"/> 1000 <input type="checkbox"/> 4000			Standard Reading: 4: <u>4.00</u> 7: <u>7.02</u> 10: <u>10.08</u> Standard Reading: <u>220</u> <u>220</u>			Readings: 0.107: <u>SEE REVERSE</u> 0.301: <u>SEE REVERSE</u> 0.491: <u>-</u>		
	Sample Data	Lead Reactor: <input type="checkbox"/> MBR1 <input checked="" type="checkbox"/> MBR2		Lag Sample: <input type="checkbox"/> if MBR1 in LEAD: SP-200B <input type="checkbox"/> <input checked="" type="checkbox"/> if MBR2 in LEAD: SP-100B		Sample Collection Time: <u>10:00 AM</u>									
Parameter		Units	Influent	*Lead Reactor	*Lag Reactor	Aeration	Media Filter Effluent	Post Sodium Hypo	Finished Water	GAC 1 Effluent	GAC 2 Effluent	IX 1 Effluent	Permitted Outfall		
pH	(std units)	7.62	6.53	6.69	7.20	7.25		7.62				7.66			
Temperature	(°C)	19.5	21.5	22.0	21.8	22.0		22.1				22.1			
ORP	(mV)	100	-354	-427	-144	58		703							
Dissolved Oxygen	(mg/L)	9.0	0.25	0.10	7.0	4.5		5.5							
Nitrate + Nitrite	(mg/L-N)	9.0	3.3	0.1				0.4							
Nitrite	(mg/L-N)	0	2.0	0.1				0							
Sulfide	(mg/L)	0	0	0.4	0.15			0							
Turbidity	(NTU)	0.22			1.09	0.22		0.11							
Chlorine Residual	(mg/L)						3.5	1.75							

* Signifies MBR1 or MBR2 depending on if reactor is in the lead or lag position - this changes every 96 hours

Note: shaded boxes are to remain blank

Treatment System Inspection		
Outlet Totalizer	gal	6728000
Target Flow Rate	gpm	10
Internal Recycle Rate	gpm	150/180
MBfR 1 pH	std units	7.2
MBfR 2 pH	std units	7.2
MBfR 1 ORP	mV	-413
MBfR 2 ORP	mV	-243
Nitrate Frequency	Hz	-
Last N Feed	ppm (N)	8.13
Last N R1	ppm (N)	0.12
Last N R2	ppm (N)	2.77
MBfR1 Sparge Rate	mm	240
MBfR2 Sparge Rate	mm	240
Phosphate Pump Settings	spr % stroke	20 30
Phosphate Concentration at Strainer	mg/LPO4	
Aeration Tank Air Flow	scfm	3.2
Air Tank Pressure	psig	2.0
Target Media Filter Flow Rate	gpm	9
Media Filter Inlet Pressure	psig	9.3
Media Filter Outlet Pressure	psig	1.5
Sodium Hypo Pump Settings	spr % stroke	40 100
Coagulant Tank Level	gal	0
Coagulant Pump Settings		-
CO2 Cylinder Pressure	psi	88
H2 Cylinder Pressure	psi	88
N2 Pressure	psi	160
N2 Flow Rate	scfm	-

Post Finished Water System Inspection		
Collect while sump is running		
Bag Filter ΔP	psi	2
GAC-1 Pressure	psig	14
GAC-2 Pressure	psig	10.5
IX-1 Pressure	psig	3.6

Feed Tank Additions		
	H3PO4	Sodium Hypo
Time	1:00	9:30AM
Initial Tank Level (gal)	2	30
Stock Added	240mL	-
Type of Water Used For Dilution	INF	-
Volume Dilution Added (gal)	3	-
Total Volume Added (gal)	3	-
Final Tank Level (gal)	5	30

Note: There are 3785 mL per gallon.

Backwash Record		
Backwash start time:		
Backwash duration	min	
Initial Product Tank Level	gal	
Final Product Tank Level	gal	
Time of sample collection:		
Location	(NTU)	TSS Collected?
Lead Purge 1		<input type="checkbox"/> Yes <input type="checkbox"/> No
Lead Purge 2		<input type="checkbox"/> Yes <input type="checkbox"/> No
Lag Purge 1		<input type="checkbox"/> Yes <input type="checkbox"/> No
Lag Purge 2		<input type="checkbox"/> Yes <input type="checkbox"/> No
Media Filter		<input type="checkbox"/> Yes <input type="checkbox"/> No

NOTES:
 2 MODULES OFF ON R1 AND 1 MODULE OFF ON R2. SODIUM HYPO PUMP WAS OFF UPON ARRIVAL (CDM TURNED IT BACK ON RIGHT AWAY). PERFORMED PH METER BACKCHECK TEST TODAY ON ALL SAMPLE POINTS USING CDM'S OAKTON

Air Monitoring					
Zero Calibration? <input type="checkbox"/> Yes <input type="checkbox"/> No	Mixed Cylinder	Aeration Tank	MBIR 1	MBIR 2	OIT Area
Time					
Carbon Monoxide (ppm)					
Oxygen (%)					
Methane (% LEL)					
Hydrogen Sulfide (ppm)					

2100P TURBIDIMETER

STANDARD	NTU
800	801
100	100
20	20.2
<0.1	0.06

NOTES CONT.:

PH6+ field meter, A HACH SENSION 1 METER BORROWED FROM CCI, AND THE INLINE PH PROBE APT HAS INSTALLED ON THE MBFR FOR R2. RESULTS ARE SHOWN IN THE TABLE BELOW. CDM TOOK SAMPLES FOR DAILY MONITORING TESTS AFTER THE PH TEST WAS PERFORMED. IT APPEARS THAT ALL PH VALUES ARE LOWER DUE TO THE CO₂ POSSIBLY OVERSHOOTING TO COMPENSATE FOR THE PH TESTING PERIOD. -

PH TEST:

SAMPLE	PRIOR TO CALIBRATION			POST CALIBRATION		
	CDM FIELD PROBE	HACH (CCI)	APT	CDM FIELD PROBE	HACH (CCI)	APT
INFLUENT	7.76	7.12	7.7	7.73	7.67	7.4
LEAD	7.14	6.99	7.1	7.15	7.27	6.7
LAG	7.63	7.45	7.6	7.66	7.67	7.2
AERATION	7.97	7.70	7.9	7.93	7.93	7.5
FILTER	7.88	7.82	7.8	7.85	7.93	7.4
FINISHED	7.92	7.85	7.9	7.86	7.93	7.5

CDM: OAKTON PH6+
 CCI: HACH SENSION 1
 APT: INLINE PH PROBE
 R2

Date: 11/2/11

Time: 9:00

Operator: ARUCAN

Field Samples													
Parameter	Units	Lead Sample		Lag Sample		Aeration	Media Filter Effluent	Post Sodium Hypo	Finished Water	GAC 1 Effluent	GAC 2 Effluent	IX 1 Effluent	Permitted Outfall
		Influent	*Lead Reactor	*Lag Reactor									
pH	(std units)	7.51	7.56	7.55	7.82	7.78			7.83				7.70
Temperature	(°C)	19.0	20.5	20.9	20.6	20.7			20.5				21.0
ORP	(mV)	90	-421	-491	-202	-50			598				
Dissolved Oxygen	(mg/L)	8	0.4	0.1	6	6.5			8				
Nitrate + Nitrite	(mg/L-N)	8.5	1.2	0					0				
Nitrite	(mg/L-N)	0	0.6	0					0				
Sulfide	(mg/L)	0	0	1.0	0.8				0				
Turbidity	(NTU)	0.273			1.22	.189			.175				
Chlorine Residual	(mg/L)								2.0	2.0			

Calibration

Sample Data

pH calibration? Yes No
 Standards: 4 7 10
 Standard Reading: 4: 4.02 7: 7.01 10: 10.10
 ORP calibration? Yes No
 Temp (Deg C): 18.1
 Standards: 0 20 200 1000 4000
 Standard Reading: 200 222
 Readings: 0.107 .148 0.201 0.277 0.519

Lead Reactor: MBR1 MBR2
 if MBR1 in LEAD: SP-200B
 if MBR2 in LEAD: SP-100B
 Sample Collection Time: 11:30

* Signifies MBR1 or MBR2 depending on if reactor is in the lead or lag position - this changes every 96 hours
 Note: shaded boxes are to remain blank

Treatment System Inspection		
Outlet Totalizer	gal	<u>6756700</u>
Target Flow Rate	gpm	<u>10</u>
Internal Recycle Rate	gpm	<u>R1=150</u> <u>R2=180</u>
MBFR 1 pH	std units	<u>7.2</u>
MBFR 2 pH	std units	<u>7.2</u>
MBFR 1 ORP	mV	<u>-392</u>
MBFR 2 ORP	mV	<u>-377</u>
Nitrate Frequency	Hz	<u>---</u>
Last N Feed	ppm (N)	<u>8.15</u>
Last N R1	ppm (N)	<u>0.40</u>
Last N R2	ppm (N)	<u>0.81</u>
MBFR1 Sparge Rate	mm	<u>240</u>
MBFR2 Sparge Rate	mm	<u>240</u>
Phosphate Pump Settings	spr % stroke	<u>20</u> <u>20</u>
Phosphate Concentration at Strainer	mg/LPO4	
Aeration Tank Air Flow	scfm	<u>3.2</u>
Air Tank Pressure	psig	<u>2.1</u>
Target Media Filter Flow Rate	gpm	<u>9.5</u>
Media Filter Inlet Pressure	psig	<u>4.1</u>
Media Filter Outlet Pressure	psig	<u>1.5</u>
Sodium Hypo Pump Settings	spr % stroke	<u>40</u> <u>100</u>
Coagulant Tank Level	gal	<u>N/A</u>
Coagulant Pump Settings		<u>OFF</u>
CO2 Cylinder Pressure	psi	<u>88</u>
H2 Cylinder Pressure	psi	<u>91</u>
N2 Pressure	psi	<u>153</u>
N2 Flow Rate	scfm	

Turbidity Meter 0.20

Post Finished Water System Inspection		
Collect while sump is running		
Bag Filter ΔP	psi	
GAC-1 Pressure	psig	
GAC-2 Pressure	psig	
IX-1 Pressure	psig	

Backwash Record		
Backwash start time:		
Backwash duration	min	
Initial Product Tank Level	gal	
Final Product Tank Level	gal	
Time of sample collection:		
Location	(NTU)	TSS Collected?
Lead Purge 1		<input type="checkbox"/> Yes <input type="checkbox"/> No
Lead Purge 2		<input type="checkbox"/> Yes <input type="checkbox"/> No
Lag Purge 1		<input type="checkbox"/> Yes <input type="checkbox"/> No
Lag Purge 2		<input type="checkbox"/> Yes <input type="checkbox"/> No
Media Filter		<input type="checkbox"/> Yes <input type="checkbox"/> No

Inventory	
Type	Check
H3PO4 Stock (gal)	<u>10</u>
Sodium Hypo Stock (gal)	<u>4</u>
Additional Field Test Kits Needed?	Dissolved Oxygen
	Nitrate + Nitrite
	Nitrite
	Sulfide
	Chlorine
o-Phosphate	<u>3</u>

NEED TO RE-ORDER HACH TURBIDITY STANDARD

Feed Tank Additions		
	H3PO4	Sodium Hypo
Time		
Initial Tank Level (gal)	<u>3.7</u>	<u>22</u>
Stock Added	<u>0</u>	<u>0</u>
Type of Water Used For Dilution	<u>N/A</u>	<u>N/A</u>
Volume Dilution Added (gal)	<u>0</u>	<u>0</u>
Total Volume Added (gal)	<u>0</u>	<u>0</u>
Final Tank Level (gal)	<u>3.7</u>	<u>22</u>

Note: There are 3785 mL per gallon.

NOTES:
 VERY WINDY ONSITE. CDM DOES WALK AROUND TO CHECK FOR DAMAGE FROM WIND. CDM LOWERED CHLORINE PUMP TO 30 STROKES/MIN. CDM COMPLETED WEEKLY SAMPLING.

Air Monitoring					
Zero Calibration? <input type="checkbox"/> Yes <input type="checkbox"/> No	Mixed Cylinder	Aeration Tank	MBIR 1	MBIR 2	OIT Area
Time					
Carbon Monoxide (ppm)					
Oxygen (%)					
Methane (% LEL)					
Hydrogen Sulfide (ppm)					

Duplicate Samples:
DUPL. # 1 - AGRATION
DUPL. # 2 - OUTFALL
DUPL. # 3 - STAC # 1

NOTES CONT.:

Date: 11/4/11

Time: 8:00

Operator: ARUCAN

Field Samples

Calibration
 pH calibration? Yes No
 Standards: 4 7 10
 Standard Reading: 4: 4.07 7: 7.05 10: 10.12
 ORP calibration? Yes No
 Temp (Deg C): 15.6
 Standard Reading: 220: 212
 Turbidity calibration? Yes No
 Standards: 20 200 1000 4000
 Readings: 0.136: .145 0.30: N/A 0.50: .521

Parameter	Units	Lead Sample		Lag Sample		Sample Collection Time:						
		Influent	*Lead Reactor	*Lag Reactor	Aeration	Media Filter Effluent	Post Sodium Hypo	Finished Water	GAC 1 Effluent	GAC 2 Effluent	IX 1 Effluent	Permitted Outfall
pH	(std units)	7.44	7.61	7.59	7.82	7.79		7.86				7.68
Temperature	(°C)	18.5	20.0	20.4	20.6	20.4		20.2				20.1
ORP	(mV)	130	-509	-540	-260	-54		620				
Dissolved Oxygen	(mg/L)	8	0.4	0.2	5	6		7				
Nitrate + Nitrite	(mg/L-N)	8.4	1.6	0				0				
Nitrite	(mg/L-N)	0	0.5	0				0				
Sulfide	(mg/L)	0	0	0.5	0.4			0				
Turbidity	(NTU)	0.307			1.05	0.179		0.157				
Chlorine Residual	(mg/L)							1.2	1.0			

* Signifies MBFR 1 or MBFR 2 depending on if reactor is in the lead or lag position - this changes every 96 hours

Outlet Totalizer	gal	6785300
Target Flow Rate	gpm	10
Internal Recycle Rate	gpm	R1 = 150 R2 = 180
MBFR 1 pH	std units	7.2
MBFR 2 pH	std units	7.2
MBFR 1 ORP	mV	-404
MBFR 2 ORP	mV	-398
Nitrate Frequency	Hz	
Last N Feed	ppm (N)	8.10
Last N R1	ppm (N)	0.28
Last N R2	ppm (N)	0.95
MBFR1 Sparge Rate	mm	240
MBFR2 Sparge Rate	mm	240
Phosphate Pump Settings	spm % stroke	30 30
Phosphate Concentration at Strainer	mg/LPO4	
Aeration Tank Air Flow	scfm	3.1
Air Tank Pressure	psig	2.0
Target Media Filter Flow Rate	gpm	9.0
Media Filter Inlet Pressure	psig	3.5
Media Filter Outlet Pressure	psig	1.5
Sodium Hypo Pump Settings	spm % stroke	30 100
Coagulant Tank Level	gal	5
Coagulant Pump Settings	ml/min	3
CO2 Cylinder Pressure	psi	88
H2 Cylinder Pressure	psi	91
N2 Pressure	psi	127
N2 Flow Rate	scfm	
Turbidity (Instrument)	NTU	.19
Turbidity (OIT)	NTU	.19

Collect while sump is running		
Bag Filter ΔP	psi	2
GAC-1 Pressure	psig	15
GAC-2 Pressure	psig	11
IX-1 Pressure	psig	1.0

Time	H3PO4	Sodium Hypo
Initial Tank Level (gal)	2.2	20
Stock Added	220ml	0
Type of Water Used For Dilution	INFL.	N/A
Volume Dilution Added (gal)	2.8	0
Total Volume Added (gal)	2.8	0
Final Tank Level (gal)	5.0	20

Backwash start time:	12:00	
Backwash duration	min	
Initial Product Tank Level	gal	
Final Product Tank Level	gal	
Time of sample collection:		
Location	(NTU)	TSS Collected?
Lead Purge 1	18.9	<input checked="" type="checkbox"/> Yes <input type="checkbox"/> No
Lead Purge 2	19.9	<input checked="" type="checkbox"/> Yes <input type="checkbox"/> No
Lag Purge 1	16.9	<input checked="" type="checkbox"/> Yes <input type="checkbox"/> No
Lag Purge 2	15.2	<input checked="" type="checkbox"/> Yes <input type="checkbox"/> No
Media Filter		<input checked="" type="checkbox"/> Yes <input type="checkbox"/> No

Type	Check	
H3PO4 Stock (gal)	4	
Sodium Hypo Stock (gal)	10	
Additional Field Test Kits Needed?	Dissolved Oxygen	10/1
	Nitrate + Nitrite	6/3
	Nitrite	5/3
	Sulfide	5/3
	Chlorine	5/3
Calibration kits needed?	o-Phosphate	0/0/0
	pH	OK 0/0/0
	ORP	OK
Turbidity	0/0/0	

NOTES:
 APT ONSITE TO ADJUST HYDROGEN LEL SENSORS. IT IS CURRENTLY RAINING ONSITE, SITE IS NOT FLOODED. CDM TO MONITOR. APT COMPLETES LEL ADJUSTMENT @ 9:30, CDM TO WAIT FOR SYSTEM TO STABILIZE

TURBIDITY TANK .27

ESTCP: Technology Demonstration Plan
 Perchlorate Destruction Using Membrane Biofilm Reduction
 ESTCP Project Number ER-200541

Air Monitoring					
Zero Calibration? <input type="checkbox"/> Yes <input type="checkbox"/> No	Mixed Cylinder	Aeration Tank	MBfR 1	MBfR 2	OIT Area
Time					
Carbon Monoxide (ppm)					
Oxygen (%)					
Methane (% LEL)					
Hydrogen Sulfide (ppm)					

NOTES CONT:

PRIOR TO TAKING SAMPLES.

Date: 4/7/11

Time: 9:30

Operator: BEROKOFF

Field Samples													
Calibration	pH calibration? <input checked="" type="checkbox"/> Yes <input type="checkbox"/> No			ORP calibration? <input checked="" type="checkbox"/> Yes <input type="checkbox"/> No			Turbidity calibration? <input checked="" type="checkbox"/> Yes <input type="checkbox"/> No						
	Standards: <input type="checkbox"/> 4 <input checked="" type="checkbox"/> 7 <input type="checkbox"/> 10			Temp (Deg C): <u> </u>			Standards: <input checked="" type="checkbox"/> 0 <input type="checkbox"/> 20 <input type="checkbox"/> 200 <input type="checkbox"/> 1000 <input type="checkbox"/> 4000						
Standard Reading: 4: <u>4.00</u> 7: <u>7.02</u> 10: <u>10.08</u>			Standard Reading: <u>OK 220</u>			Readings: <u>ORDERED/SHIPPING</u>							
4: <u>4.00</u> 7: <u>7.02</u> 10: <u>10.08</u>			Standard Reading: <u>OK 220</u>			0.136: <u> </u> 0.30: <u> </u> 0.50: <u> </u>							
Lead Sample <input type="checkbox"/> Lag Sample <input type="checkbox"/> Lead Reactor: <input type="checkbox"/> MBFR1 <input checked="" type="checkbox"/> MBFR2 <input type="checkbox"/> SP-100A <input type="checkbox"/> if MBFR1 in LEAD: SP-200B <input type="checkbox"/> if MBFR2 in LEAD: SP-100B <input checked="" type="checkbox"/>													
Sample Collection Time: <u>10am</u>													
Sample Data	Parameter	Units	Influent	*Lead Reactor	*Lag Reactor	Aeration	Media Filter Effluent	Post Sodium Hypo	Finished Water	GAC 1 Effluent	GAC 2 Effluent	IX 1 Effluent	Permitted Outfall
	pH	(std units)	7.53	7.57	7.57	7.93	7.81		7.90				7.69
	Temperature	(°C)	18.6	20.6	20.9	20.7	20.6		18.8				18.6
	ORP	(mV)	301	-610	-440	-214	50		641				
	Dissolved Oxygen	(mg/L)	9	0.25	0.1	7	3.5		4.5				
	Nitrate + Nitrite	(mg/L-N)	9	1.75	0				0				
	Nitrite	(mg/L-N)	0	0.6	0				0				
	Sulfide	(mg/L)	0	0	1.0	0.8			0				
	Turbidity	(NTU)	0.075			1.20	0.132		0.144				
	Chlorine Residual	(mg/L)							2.0	1.75			

* Signifies MBFR 1 or MBFR 2 depending on if reactor is in the lead or lag position - this changes every 96 hours

Note: shaded boxes are to remain blank

Post Finished Water System Inspection		
Collect while sump is running		
Bag Filter ΔP	psi	2
GAC-1 Pressure	psig	14
GAC-2 Pressure	psig	9
IX-1 Pressure	psig	1.4

Feed Tank Additions		
	H3PO4	Sodium Hypo
Time	11:00	11:00
Initial Tank Level (gal)	3	14
Stock Added	-	-
Type of Water Used For Dilution	-	-
Volume Dilution Added (gal)	-	-
Total Volume Added (gal)	-	-
Final Tank Level (gal)	3	14

Note: There are 3785 mL per gallon.

Backwash Record		
Backwash start time:		
Backwash duration	min	
Initial Product Tank Level	gal	
Final Product Tank Level	gal	
Time of sample collection:		
Location	(NTU)	TSS Collected?
Lead Purge 1		<input type="checkbox"/> Yes <input type="checkbox"/> No
Lead Purge 2		<input type="checkbox"/> Yes <input type="checkbox"/> No
Lag Purge 1		<input type="checkbox"/> Yes <input type="checkbox"/> No
Lag Purge 2		<input type="checkbox"/> Yes <input type="checkbox"/> No
Media Filter		<input type="checkbox"/> Yes <input type="checkbox"/> No

NOTES:

GALLADE CHEMICAL DELIVERED (4)(3) 15gal CARBOYS TODAY OF 12.5% SODIUM HYPO. APT TO BE ON SITE THIS AFTERNOON TO PERFORM WORK ON SYSTEM.

Treatment System Inspection		
Outlet Totalizer	gal	887700
Target Flow Rate	gpm	10
Internal Recycle Rate	gpm	150/180
MBFR 1 pH	std units	7.2
MBFR 2 pH	std units	7.2
MBFR 1 ORP	mV	-390
MBFR 2 ORP	mV	-427
Nitrate Frequency	Hz	-
Last N Feed	ppm (N)	8.10
Last N R1	ppm (N)	0.21
Last N R2	ppm (N)	0.92
MBFR1 Sparge Rate	mm	240
MBFR2 Sparge Rate	mm	240
Phosphate Pump Settings	spm	30
	% stroke	30
Phosphate Concentration at Strainer	mg/LPO4	1.5
Aeration Tank Air Flow	scfm	3.2
Air Tank Pressure	psig	2.0
Target Media Filter Flow Rate	gpm	9
Media Filter Inlet Pressure	psig	2.0
Media Filter Outlet Pressure	psig	1.5
Sodium Hypo Pump Settings	spm	30
	% stroke	100
Coagulant Tank Level	gal	0
Coagulant Pump Settings	ml/min	-
CO2 Cylinder Pressure	psi	87
H2 Cylinder Pressure	psi	88
N2 Pressure	psi	156
N2 Flow Rate	scfm	-
Turbidity (Instrument)	NTU	0.19
Turbidity (OIT)	NTU	0.26

Date: 11/9/11

Time: 8:45 AM

Operator: BEROKOFF

Field Samples

Calibration	pH calibration? <input checked="" type="checkbox"/> Yes <input type="checkbox"/> No	ORP calibration? <input checked="" type="checkbox"/> Yes <input type="checkbox"/> No	Turbidity calibration? <input checked="" type="checkbox"/> Yes <input type="checkbox"/> No										
	Standards: <input checked="" type="checkbox"/> 4 <input checked="" type="checkbox"/> 7 <input checked="" type="checkbox"/> 10	Temp (Deg C): <u>12.8</u>	Standards: <input checked="" type="checkbox"/> 0 <input checked="" type="checkbox"/> 20 <input checked="" type="checkbox"/> 200 <input checked="" type="checkbox"/> 1000 <input checked="" type="checkbox"/> 4000										
	Standard Reading: 4: <u>4.00</u> 7: <u>7.00</u> 10: <u>10.15</u>	Standard Reading: 220: <u>2.21</u>	Readings: 0.136: <u>0.150</u> 0.30: <u>0.317</u> 0.50: <u>0.317</u>										
Sample Data	Lead Reactor: <input type="checkbox"/> MfBR1 <input checked="" type="checkbox"/> MfBR2	Lead Sample <input type="checkbox"/> SP-100A <input type="checkbox"/> <input type="checkbox"/> if MfBR1 in LEAD: SP-200B <input type="checkbox"/> <input checked="" type="checkbox"/> if MfBR2 in LEAD: SP-100B	Lag Sample		Sample Collection Time: <u>9:30</u>								
	Parameter	Units	Influent	*Lead Reactor	*Lag Reactor	Aeration	Media Filter Effluent	Post Sodium Hypo	Finished Water	GAC 1 Effluent	GAC 2 Effluent	IX 1 Effluent	Permitted Outfall
	pH	(std units)	7.62	7.36	7.03	7.98	7.84		7.92				7.69
	Temperature	(°C)	18.8	20.9	21.3	21.1	21.0		19.4				19.6
	ORP	(mV)	432	-482	-487	-222	52		655				
	Dissolved Oxygen	(mg/L)	9.0	0.15	0.10	7.0	3.5		4.5				
	Nitrate + Nitrite	(mg/L-N)	9.0	1.6	0				0				
	Nitrite	(mg/L-N)	0	0.6	0				0				
	Sulfide	(mg/L)	0	0	1.3	0.8			0				
	Turbidity	(NTU)	-				*		*				
	Chlorine Residual	(mg/L)							1.9	1.6			

NOT DELIVERED YET (BACKWASH)

Treatment System Inspection

Outlet Totalizer	gal	6855100
Target Flow Rate	gpm	10
Internal Recycle Rate	gpm	150/180
MBfR 1 pH	std units	7.2
MBfR 2 pH	std units	7.2
MBfR 1 ORP	mV	-601
MBfR 2 ORP	mV	-534
Nitrate Frequency	Hz	-
Last N Feed	ppm (N)	8.12
Last N R1	ppm (N)	0.23
Last N R2	ppm (N)	0.86
MBfR1 Sparge Rate	mm	240
MBfR2 Sparge Rate	mm	240
Phosphate Pump Settings	spm	20
	% stroke	30
Phosphate Concentration at Strainer	mg/LPO4	
Aeration Tank Air Flow	scfm	3.2
Air Tank Pressure	psig	2.0
Target Media Filter Flow Rate	gpm	9
Media Filter Inlet Pressure	psig	11
Media Filter Outlet Pressure	psig	1.5
Sodium Hypo Pump Settings	spm	30
	% stroke	100
Coagulant Tank Level	gal	8
Coagulant Pump Settings	ml/min	OFF
CO2 Cylinder Pressure	psi	87
H2 Cylinder Pressure	psi	88
N2 Pressure	psi	155
N2 Flow Rate	scfm	-
Turbidity (Instrument)	NTU	0.21
Turbidity (OIT)	NTU	0.21

* Signifies MBfR 1 or MBfR 2 depending on if reactor is in the lead or lag position - this changes every 96 hours
 * DIDNT TAKE TURBIDITY DUE TO MEDIA FILTER UNDERGOING BACKWASH

Note: shaded boxes are to remain blank

Post Finished Water System Inspection

Collect while sump is running

Bag Filter ΔP	psi	2
GAC-1 Pressure	psig	13.6
GAC-2 Pressure	psig	9
IX-1 Pressure	psig	1.4

Backwash Record

Backwash start time: _____

Backwash duration: _____ min

Initial Product Tank Level: _____ gal

Final Product Tank Level: _____ gal

Time of sample collection: _____

Location	(NTU)	TSS Collected?
Lead Purge 1		<input type="checkbox"/> Yes <input type="checkbox"/> No
Lead Purge 2		<input type="checkbox"/> Yes <input type="checkbox"/> No
Lag Purge 1		<input type="checkbox"/> Yes <input type="checkbox"/> No
Lag Purge 2		<input type="checkbox"/> Yes <input type="checkbox"/> No
Media Filter		<input type="checkbox"/> Yes <input type="checkbox"/> No

Inventory

Type	Check	
H3PO4 Stock (gal)	7	
Sodium Hypo Stock (gal)	50+	
Additional Field Test Kits Needed?	Dissolved Oxygen	4/0
	Nitrate + Nitrite	6
	Nitrite	6
	Sulfide	3
	Chlorine	5
Calibration Kits needed?	o-Phosphate	3
	pH	✓
	ORP	✓
	Turbidity	✓

Feed Tank Additions

	H3PO4	Sodium Hypo
Time	1:00	1:00
Initial Tank Level (gal)	1.5	7
Stock Added	280	-
Type of Water Used For Dilution	INF	-
Volume Dilution Added (gal)	3.5	-
Total Volume Added (gal)	3.5	-
Final Tank Level (gal)	5.0	7

NOTES:
 APT INSTALLED LARGER COAGULANT CONTAINER (~15gal) BUT THE PUMP WAS OFF, NOT FEEDING THE SYSTEM. TURBIDITY WAS ~~VERY~~ LOW ON BOTH APT INSTRUMENTS (0.21) SO THERE DOES NOT APPEAR TO BE A NEED FOR COAGULANT DOSING AT THIS POINT.

Note: There are 3785 mL per gallon.

Date: 11/11/11

Time: 8:30

Operator: ARUCAN

Field Samples

Calibration	pH calibration? <input checked="" type="checkbox"/> Yes <input type="checkbox"/> No Standards: <input checked="" type="checkbox"/> 4 <input checked="" type="checkbox"/> 7 <input checked="" type="checkbox"/> 10 Standard Reading: 4: <u>4.01</u> 7: <u>7.01</u> 10: <u>10.08</u>	ORP calibration? <input checked="" type="checkbox"/> Yes <input type="checkbox"/> No Temp (Deg C): <u>24.4</u> Standard Reading: 220: <u>214</u>	Turbidity calibration? <input checked="" type="checkbox"/> Yes <input type="checkbox"/> No Standards: <input checked="" type="checkbox"/> 10 <input checked="" type="checkbox"/> 20 <input checked="" type="checkbox"/> 200 <input checked="" type="checkbox"/> 1000 <input checked="" type="checkbox"/> 4000 Readings: 0.136: <u>152</u> 0.30: <u>0.324</u> 0.50: <u>0.536</u>
	Lead Sample Lag Sample Lead Reactor: <input type="checkbox"/> MfBR1 <input type="checkbox"/> MfBR2 SP-100A <input type="checkbox"/> if MBfR1 in LEAD: SP-200B <input type="checkbox"/> if MBfR2 in LEAD: SP-100B <input type="checkbox"/> Sample Collection Time: <u>10:30</u>		
	Parameter Units Influent *Lead Reactor *Lag Reactor Aeration Media Filter Effluent Post Sodium Hypo Finished Water GAC 1 Effluent GAC 2 Effluent IX 1 Effluent Permitted Outfall		

Parameter	Units	Influent	*Lead Reactor	*Lag Reactor	Aeration	Media Filter Effluent	Post Sodium Hypo	Finished Water	GAC 1 Effluent	GAC 2 Effluent	IX 1 Effluent	Permitted Outfall
pH	(std units)	7.34	7.44	7.65	7.95	7.83		7.87				
Temperature	(°C)	19.0	21.2	21.8	21.7	21.3		21.4				
ORP	(mV)	180	-500	-536	-254	-20		530				
Dissolved Oxygen	(mg/L)	9	0.4	0.25	6	6.5		8				
Nitrate + Nitrite	(mg/L-N)	8.5	1.4	0				0				
Nitrite	(mg/L-N)	0	0.6	0				0				
Sulfide	(mg/L)	0	0	1.2	0.8			0				
Turbidity	(NTU)	0.688			0.898	0.229		0.238				
Chlorine Residual	(mg/L)						1.2	1.0				

* Signifies MBfR 1 or MBfR 2 depending on if reactor is in the lead or lag position - this changes every 96 hours

Note: shaded boxes are to remain blank

Treatment System Inspection

Outlet Totalizer	gal	6883900
Target Flow Rate	gpm	10
Internal Recycle Rate	gpm	MBfR 1 = 150 MBfR 2 = 180
MBfR 1 pH	std units	7.2
MBfR 2 pH	std units	7.2
MBfR 1 ORP	mV	-606
MBfR 2 ORP	mV	-542
Nitrate Frequency	Hz	—
Last N Feed	ppm (N)	8.14
Last N R1	ppm (N)	0.28
Last N R2	ppm (N)	0.89
MBfR1 Sparge Rate	mm	240
MBfR2 Sparge Rate	mm	240
Phosphate Pump Settings	spm % stroke	20 30
Phosphate Concentration at Strainer	mg/LPO4	1.1
Aeration Tank Air Flow	scfm	3.2
Air Tank Pressure	psig	2.0
Target Media Filter Flow Rate	gpm	9.0
Media Filter Inlet Pressure	psig	9.5
Media Filter Outlet Pressure	psig	1.5
Sodium Hypo Pump Settings	spm % stroke	30 100
Coagulant Tank Level	gal	15 (Full)
Coagulant Pump Settings	m/min	17
CO2 Cylinder Pressure	psi	88
H2 Cylinder Pressure	psi	91
N2 Pressure	psi	147
N2 Flow Rate	scfm	—
Turbidity (Instrument)	NTU	0.22
Turbidity (OIT)	NTU	0.23

Post Finished Water System Inspection	
Collect while sump is running	
Bag Filter ΔP	psi
GAC-1 Pressure	psig
GAC-2 Pressure	psig
IX-1 Pressure	psig

Feed Tank Additions		
	H3PO4	Sodium Hypo
Time	11:30	11:30
Initial Tank Level (gal)	3.5	5
Stock Added	0	
Type of Water Used For Dilution	NA	FILT. EFF.
Volume Dilution Added (gal)	0	
Total Volume Added (gal)	0	
Final Tank Level (gal)	3.5	

Note: There are 3785 mL per gallon.

Backwash Record		
Backwash start time:	11:50	
Backwash duration	min	35
Initial Product Tank Level	gal	
Final Product Tank Level	gal	
Time of sample collection:		
Location	(NTU)	TSS Collected?
Lead Purge 1	19.4	<input checked="" type="checkbox"/> Yes <input type="checkbox"/> No
Lead Purge 2	18.8	<input checked="" type="checkbox"/> Yes <input type="checkbox"/> No
Lag Purge 1	5.3	<input checked="" type="checkbox"/> Yes <input type="checkbox"/> No
Lag Purge 2	6.0	<input checked="" type="checkbox"/> Yes <input type="checkbox"/> No
Media Filter		<input checked="" type="checkbox"/> Yes <input type="checkbox"/> No

NOTES:
 COM ONSITE, A SLIGHT SMELL OF SULFUR/SULFIDE IN MBfR
 AERATION AREA. COM PERFORMED A SPARGE @ 12:00. SAMPLES
 WERE TAKEN FOR TSS. COM CLEANED NITRATE ANALYZER LENS
 WITH DI WATER AND CHEM WIPES. THE NITRATE ANALYZER

Inventory		
Type	Check	
H3PO4 Stock (gal)	3	
Sodium Hypo Stock (gal)	45	
Additional Field Test Kits Needed?	Dissolved Oxyge	12
	Nitrate + Nitrite	6
	Nitrite	6
	Sulfide	3
	Chlorine	5
Calibration Kits needed?	o-Phosphate	3
	pH	3 (1 GAL EACH)
	ORP	✓
	Turbidity	REORDER

Air Monitoring					
Zero Calibration? <input type="checkbox"/> Yes <input type="checkbox"/> No	Mixed Cylinder	Aeration Tank	MBIR 1	MBIR 2	OIT Area
Time					
Carbon Monoxide (ppm)					
Oxygen (%)					
Methane (% LEL)					
Hydrogen Sulfide (ppm)					

NOTES CONT:

~~FEED~~ FEED LINES HAVE BEEN RE-ROUTED AS PER APT'S DIRECTION. THE NITRATE ANALYZER NUMBERS WERE TAKEN BEFORE AND AFTER RE-ROUTE. CAN REFILLED CALORINE AND CHANGED SETTINGS TO 40 SPIN AND 100% STROKE LENGTH.

Date: 11/14/11

Time: 8:00

Operator: BRUCIAN

Field Samples

Calibration	pH calibration? <input type="checkbox"/> Yes <input type="checkbox"/> No Standards: <input type="checkbox"/> 4 <input type="checkbox"/> 7 <input type="checkbox"/> 10 Standard Reading: _____		ORP calibration? <input type="checkbox"/> Yes <input type="checkbox"/> No Temp (Deg C): _____		Turbidity calibration? <input type="checkbox"/> Yes <input type="checkbox"/> No Standards: <input type="checkbox"/> 0 <input type="checkbox"/> 20 <input type="checkbox"/> 200 <input type="checkbox"/> 1000 <input type="checkbox"/> 4000 Readings: _____								
	4: _____	7: _____	10: _____	Standard Reading: 220: _____		0.136: _____	0.30: _____	0.50: _____					
Sample Data	Lead Reactor: <input type="checkbox"/> MfBR1 <input type="checkbox"/> MfBR2		Lead Sample SP-100A <input type="checkbox"/> Lag Sample if MBfR1 in LEAD: SP-200B <input type="checkbox"/> if MBfR2 in LEAD: SP-100B <input type="checkbox"/>		Sample Collection Time: _____								
	Parameter	Units	Influent	*Lead Reactor	*Lag Reactor	Aeration	Media Filter Effluent	Post Sodium Hypo	Finished Water	GAC 1 Effluent	GAC 2 Effluent	IX 1 Effluent	Permitted Outfall
	pH	(std units)											
	Temperature	(°C)											
	ORP	(mV)											
	Dissolved Oxygen	(mg/L)											
	Nitrate + Nitrite	(mg/L-N)											
	Nitrite	(mg/L-N)											
	Sulfide	(mg/L)											
	Turbidity	(NTU)											
Chlorine Residual	(mg/L)												

* Signifies MBfR 1 or MBfR 2 depending on if reactor is in the lead or lag position - this changes every 96 hours

Note: shaded boxes are to remain blank

Outlet Totalizer	gal	
Target Flow Rate	gpm	10
Internal Recycle Rate	gpm	R1 = 150 R2 = 150
MBfR 1 pH	std units	7.2
MBfR 2 pH	std units	7.2
MBfR 1 ORP	mV	-644
MBfR 2 ORP	mV	-499
Nitrate Frequency	Hz	0
Last N Feed	ppm (N)	8.10
Last N R1	ppm (N)	0.16
Last N R2	ppm (N)	1.75
MBfR1 Sparge Rate	mm	240
MBfR2 Sparge Rate	mm	40
Phosphate Pump Settings	spm	20
Phosphate Concentration at Strainer	% stroke	30
Phosphate Concentration at Strainer	mg/LPO4	
Aeration Tank Air Flow	scfm	3.2
Air Tank Pressure	psig	2.1
Target Media Filter Flow Rate	gpm	9
Media Filter Inlet Pressure	psig	9.8
Media Filter Outlet Pressure	psig	8.9
Sodium Hypo Pump Settings	spm	40
	% stroke	100
Coagulant Tank Level	gal	—
Coagulant Pump Settings	ml/min	—
CO2 Cylinder Pressure	psi	91.8
H2 Cylinder Pressure	psi	91
N2 Pressure	psi	160
N2 Flow Rate	scfm	—
Turbidity (Instrument)	NTU	0.27
Turbidity (OIT)	NTU	0.27

Post Finished Water System Inspection

Collect while sump is running

Bag Filter ΔP	psi	
GAC-1 Pressure	psig	
GAC-2 Pressure	psig	
IX-1 Pressure	psig	

Backwash Record

Backwash start time: _____		
Backwash duration	min	
Initial Product Tank Level	gal	
Final Product Tank Level	gal	
Time of sample collection:		
Location	(NTU)	TSS Collected?
Lead Purge 1		<input type="checkbox"/> Yes <input type="checkbox"/> No
Lead Purge 2		<input type="checkbox"/> Yes <input type="checkbox"/> No
Lag Purge 1		<input type="checkbox"/> Yes <input type="checkbox"/> No
Lag Purge 2		<input type="checkbox"/> Yes <input type="checkbox"/> No
Media Filter		<input type="checkbox"/> Yes <input type="checkbox"/> No

Inventory

Type	Check
H3PO4 Stock (gal)	
Sodium Hypo Stock (gal)	
Additional Field Test Kits Needed?	Dissolved Oxygen
	Nitrate + Nitrite
	Nitrite
	Sulfide
	o-Phosphate
Calibration kits needed?	pH
	ORP
	Turbidity

Feed Tank Additions

Time	H3PO4	Sodium Hypo
	1:30	—
Initial Tank Level (gal)	1.5	25
Stock Added	240	0
Type of Water Used For Dilution	INFLUENT	NA
Volume Dilution Added (gal)	3.5	0
Total Volume Added (gal)	3.5	0
Final Tank Level (gal)	5.0	25

Note: There are 3785 mL per gallon.

NOTES:

SCHEDULED BATCH TEST FOR TODAY. COM WAS INSTRUCTED TO CLOSE THE REJECT TANK TO SUMP PUMP VALVE. DURING THE WEEKEND THE REJECT TANK LINE HAD BECOME CLOGGED NOT ALLOWING IT TO DRAIN.

TEST STARTED @
 9:35

Air Monitoring						
Zero Calibration? <input type="checkbox"/> Yes <input type="checkbox"/> No	Mixed Cylinder	Aeration Tank	MBfR 1	MBfR 2	OIT Area	
Time						
Carbon Monoxide (ppm)						
Oxygen (%)						
Methane (% LEL)						
Hydrogen Sulfide (ppm)						

NOTES CONT.:

THE MBfR HAS NOT BEEN ABLE TO SPARGE SINCE SATURDAY. COM CLOSED FILTER AIO FEED DUE TO LEAK AT PUMP HEAD. BATCH TESTING STARTED @ 9:35. ALARMS FOR HIGH LEVEL HAS STOP THE TEST. COM RESTARTS TEST @ 10:30.

NOTES: CDM ONSITE @ 8:00. SYSTEM IS
 OPERATING NORMAL SINCE 4/15/11. CDM TO
 CONDUCT BATCH TEST ON REACTOR 1.
 LEAD REACTOR IS CURRENTLY #2. CDM TO
 FOLLOW STEPS 38-71 ON BATCH TEST PROTOCOL.
 TESTING STARTED @ 9:29. A LEAK WAS FOUND
 ON RECIRC. PUMP #2. IT IS THE SOURCE OF A
 FLOODING THE SITE. BATCH TESTING ENDS @
 3:40. CDM RETURNS ALL SETTINGS BACK AS DESCR.
 IN STEP 71. NITRATE ANALYZER LINES WERE RETURNED
 TO THEIR NORMAL SAMPLING PORT. CDM SET
 SPARGE BACK TO 12 HOURS AND IMMEDIATELY
 INITIATED A SPARGE. CDM STAYED ONSITE TO
 MONITOR SITE. CDM ALSO REMOVED FLOODED
 WATER DUE TO LEAK. LEVEL ON REACTORS APPEAR
 TO BE STABLE AT 4-INCHES BELOW HIGH-LEVEL
 ALARM.

8944900
 R1 = 150
 R2 = 186
 10 GPM
 8.12
 0.12
 1.60
 7.2
 7.2
 -434 580
 -434
 FILTER
 1.9
 1.5
 9.0 GPM

NOTE: APT INFORMED ME THAT REJECT TANK
 HAS APPROX. 4-6 INCHES OF FILTER MEDIA ON
 THE BOTTOM. WE HAVE CALCULATED THE TOTAL
 VOLUME TO BE 2-4 CUBIC FEET OF MEDIA.
 THE FILTERS ONLY CONTAIN 8 CUFT OF MEDIA.
 THE BACKFLUSH MAY BE CAUSING THIS.

-ALSO CAMERON WELDING ONSITE TO REFILL
 NITROGEN

SPARGE
 240.0
 70.0
 AERATION
 3.2
 2.1
 GASES
 91
 88
 109

Date: 11/18/11

Time: 9AM

Operator: BERAKOFF

Field Samples													
Calibration	pH calibration? <input checked="" type="checkbox"/> Yes <input type="checkbox"/> No Standards: <input checked="" type="checkbox"/> 4 <input checked="" type="checkbox"/> 7 <input checked="" type="checkbox"/> 10 Standard Reading: 4: <u>4.00</u> 7: <u>7.06</u> 10: <u>10.10</u>			ORP calibration? <input checked="" type="checkbox"/> Yes <input type="checkbox"/> No Temp (Deg C): <u>11</u> Standard Reading: 220: <u>200</u>			Turbidity calibration? <input checked="" type="checkbox"/> Yes <input type="checkbox"/> No Standards: <input checked="" type="checkbox"/> 0 <input checked="" type="checkbox"/> 20 <input checked="" type="checkbox"/> 200 <input checked="" type="checkbox"/> 1000 <input checked="" type="checkbox"/> 4000 Readings: 0.136: _____ 0.30: _____ 0.50: _____						
	Lead Sample <input type="checkbox"/> Lag Sample <input type="checkbox"/> Lead Reactor: <input type="checkbox"/> MBR1 <input type="checkbox"/> MBR2 <input type="checkbox"/> SP-100A <input type="checkbox"/> if MBR1 in LEAD: SP-200B <input type="checkbox"/> if MBR2 in LEAD: SP-100B <input type="checkbox"/>			Sample Collection Time: <u>10AM</u>									
Sample Data	Parameter	Units	Influent	*Lead Reactor	*Lag Reactor	Aeration	Media Filter Effluent	Post Sodium Hypo	Finished Water	GAC 1 Effluent	GAC 2 Effluent	IX 1 Effluent	Permitted Outfall
	pH	(std units)	<u>7.53</u>	<u>7.47</u>	<u>7.61</u>	<u>7.98</u>	<u>7.93</u>		<u>7.98</u>				<u>7.60</u>
	Temperature	(°C)	<u>18.5</u>	<u>20.0</u>	<u>20.5</u>	<u>20.3</u>	<u>20.1</u>		<u>18.6</u>				<u>18.4</u>
	ORP	(mV)	<u>120</u>	<u>-477</u>	<u>-500</u>	<u>-173</u>	<u>74</u>		<u>616</u>				
	Dissolved Oxygen	(mg/L)	<u>9.0</u>	<u>0.3</u>	<u>0.05</u>	<u>7.0</u>	<u>5.5</u>		<u>5.5</u>				
	Nitrate + Nitrite	(mg/L-N)	<u>9.0</u>	<u>1.75</u>	<u>0</u>				<u>0</u>				
	Nitrite	(mg/L-N)	<u>0</u>	<u>0.75</u>	<u>0</u>				<u>0</u>				
	Sulfide	(mg/L)	<u>0</u>	<u>0</u>	<u>0.4</u>	<u>0.1</u>			<u>0</u>				
	Turbidity	(NTU)	<u>0.067</u>			<u>1.024</u>	<u>0.288</u>		<u>0.268</u>				
	Chlorine Residual	(mg/L)						<u>1.5</u>	<u>1.25</u>				

* Signifies MBR 1 or MBR 2 depending on if reactor is in the lead or lag position - this changes every 96 hours

Note: shaded boxes are to remain blank.

Treatment System Inspection		
Outlet Totalizer	gal	<u>6972300</u>
Target Flow Rate	gpm	<u>10</u>
Internal Recycle Rate	gpm	<u>150/180</u>
MBFR 1 pH	std units	<u>7.2</u>
MBFR 2 pH	std units	<u>7.2</u>
MBFR 1 ORP	mV	<u>-472</u>
MBFR 2 ORP	mV	<u>-440</u>
Nitrate Frequency	Hz	<u>-</u>
Last N Feed	ppm (N)	<u>8.15</u>
Last N R1	ppm (N)	<u>0</u>
Last N R2	ppm (N)	<u>1.35</u>
MBFR1 Sparge Rate	mm	<u>240</u>
MBFR2 Sparge Rate	mm	<u>240</u>
Phosphate Pump Settings	spm % stroke	<u>20 30</u>
Phosphate Concentration at Strainer	mg/LPO4	
Aeration Tank Air Flow	scfm	<u>3.2</u>
Air Tank Pressure	psig	<u>2.0</u>
Target Media Filter Flow Rate	gpm	<u>9</u>
Media Filter Inlet Pressure	psig	<u>7.4</u>
Media Filter Outlet Pressure	psig	<u>1.5</u>
Sodium Hypo Pump Settings	spm % stroke	
Coagulant Tank Level	gal	<u><1.0</u>
Coagulant Pump Settings	ml/min	<u>17*</u>
CO2 Cylinder Pressure	psi	<u>88</u>
H2 Cylinder Pressure	psi	<u>88</u>
N2 Pressure	psi	<u>144</u>
N2 Flow Rate	scfm	<u>-</u>
Turbidity (Instrument)	NTU	<u>0.27</u>
Turbidity (OIT)	NTU	<u>0.75</u>

Post Finished Water System Inspection		
Collect while sump is running		
Bag Filter ΔP	psi	<u>2</u>
GAC-1 Pressure	psig	<u>6</u>
GAC-2 Pressure	psig	<u>1.0</u>
IX-1 Pressure	psig	<u>1.3</u>

Feed Tank Additions		
	H3PO4	Sodium Hypo
Time	<u>1:00</u>	<u>9:30</u>
Initial Tank Level (gal)	<u>1.8</u>	<u>15</u>
Stock Added		<u>-</u>
Type of Water Used For Dilution	<u>INF</u>	<u>-</u>
Volume Dilution Added (gal)	<u>3.2</u>	<u>-</u>
Total Volume Added (gal)	<u>3.2</u>	<u>-</u>
Final Tank Level (gal)	<u>5.0</u>	<u>15</u>

Note: There are 3785 mL per gallon.

Backwash Record		
Backwash Start time:		
Backwash duration	min	
Initial Product Tank Level	gal	
Final Product Tank Level	gal	
Time of sample collection:		
Location	(NTU)	TSS Collected?
Lead Purge 1		<input type="checkbox"/> Yes <input type="checkbox"/> No
Lead Purge 2		<input type="checkbox"/> Yes <input type="checkbox"/> No
Lag Purge 1		<input type="checkbox"/> Yes <input type="checkbox"/> No
Lag Purge 2		<input type="checkbox"/> Yes <input type="checkbox"/> No
Media Filter		<input type="checkbox"/> Yes <input type="checkbox"/> No

NOTES:

* COAGULANT TANK WAS EMPTY UPON ARRIVAL. COAGULANT PUMP WAS RUNNING BUT NOT DOSING SYSTEM SO CDM TURNED OFF PUMP.

Inventory	
Type	Check
H3PO4 Stock (gal)	
Sodium Hypo Stock (gal)	
Additional Field Test Kits Needed?	Dissolved Oxyge
	Nitrate + Nitrite
	Nitrite
	Sulfide
	Chlorine
Calibration kits needed?	α-Phosphate
	pH
	ORP
	Turbidity

Date: 11/22/11

Time: 10:30

Operator: ARUCAN

Field Samples

Calibration	pH calibration? <input checked="" type="checkbox"/> Yes <input type="checkbox"/> No	ORP calibration? <input checked="" type="checkbox"/> Yes <input type="checkbox"/> No	Turbidity calibration? <input checked="" type="checkbox"/> Yes <input type="checkbox"/> No
	Standards: <input checked="" type="checkbox"/> 4 <input checked="" type="checkbox"/> 7 <input checked="" type="checkbox"/> 10	Temp (Deg C): <u>11.4</u>	Standards: <input type="checkbox"/> 10 <input checked="" type="checkbox"/> 20 <input checked="" type="checkbox"/> 200 <input checked="" type="checkbox"/> 1000 <input checked="" type="checkbox"/> 4000
	Standard Reading: 4: <u>4.04</u> 7: <u>7.02</u> 10: <u>10.09</u>	Standard Reading: 220: <u>213</u>	Readings: 0.136: <u>1.48</u> 0.30: <u>0.326</u> 0.50: <u>0.541</u>

Lead Sample Lag Sample
 Lead Reactor: MBfR1 MBfR2 SP-100A if MBfR1 in LEAD: SP-200B if MBfR2 in LEAD: SP-100B
 Sample Collection Time: 12:30

Parameter	Units	Influent	*Lead Reactor	*Lag Reactor	Aeration	Media Filter Effluent	Post Sodium Hypo	Finished Water	GAC 1 Effluent	GAC 2 Effluent	IX 1 Effluent	Permitted Outfall
pH	(std units)	7.56	7.57	7.66	7.98	7.85		7.91				7.58
Temperature	(°C)	18.8	19.3	20.5	20.4	20.3		17.8				20.1
ORP	(mV)	80	-400	-530	-190	20		320				
Dissolved Oxygen	(mg/L)	9.0	0.8	0.1	5	6		7.5				
Nitrate + Nitrite	(mg/L-N)	8.5	2.0	0				0				
Nitrite	(mg/L-N)	0	0.6	0				0				
Sulfide	(mg/L)	0	0	0.1	0.1			0				
Turbidity	(NTU)	0.103			1.78	0.201		0.197				
Chlorine Residual	(mg/L)						0.2	0.1				

* Signifies MBfR 1 or MBfR 2 depending on if reactor is in the lead or lag position - this changes every 96 hours

Note: shaded boxes are to remain blank

Treatment System Inspection

Outlet Totalizer	gal	7019400
Target Flow Rate	gpm	10
Internal Recycle Rate	gpm	15/180
MBfR 1 pH	std units	7.2
MBfR 2 pH	std units	7.2
MBfR 1 ORP	mV	-469
MBfR 2 ORP	mV	-324
Nitrate Frequency	Hz	
Last N Feed	ppm (N)	8.12
Last N R1	ppm (N)	0.64
Last N R2	ppm (N)	2.33
MBfR1 Sparge Rate	mm	240
MBfR2 Sparge Rate	mm	240
Phosphate Pump Settings	spm % stroke	20 30
Phosphate Concentration at Strainer	mg/LPO4	
Aeration Tank Air Flow	scfm	3.2
Air Tank Pressure	psig	2.0
Target Media Filter Flow Rate	gpm	9.0
Media Filter Inlet Pressure	psig	11.3
Media Filter Outlet Pressure	psig	1.5
Sodium Hypo Pump Settings	spm % stroke	40 100
Coagulant Tank Level	gal	5
Coagulant Pump Settings	ml/min	7
CO2 Cylinder Pressure	psi	87
H2 Cylinder Pressure	psi	91
N2 Pressure	psi	144
N2 Flow Rate	scfm	
Turbidity (Instrument)	NTU	0.17
Turbidity (OIT)	NTU	0.19

Post Finished Water System Inspection

Collect while sump is running

Bag Filter ΔP	psi	3
GAC-1 Pressure	psig	15
GAC-2 Pressure	psig	10
IX-1 Pressure	psig	1.5

Feed Tank Additions

	H3PO4	Sodium Hypo
Time	2:15	2:30
Initial Tank Level (gal)	1.5	9.0
Stock Added	2.75	5
Type of Water Used For Dilution	INF	MF
Volume Dilution Added (gal)	3.5	16
Total Volume Added (gal)	3.5	21
Final Tank Level (gal)	4.5	30

Note: There are 3785 mL per gallon.

Backwash Record

~~Backwash start time:
 Backwash duration: min
 Initial Product Tank Level: gal
 Final Product Tank Level: gal
 Time of sample collection:
 Location (NTU) TSS Collected?
 Lead Purge 1 Yes No
 Lead Purge 2 Yes No
 Lag Purge 1 Yes No
 Lag Purge 2 Yes No
 Media Filter Yes No~~

NOTES:

APT LOWERED INFLUENT FLOWRATE TO 8 GPM. COM
 HAD CHANGE PHOSPHATE DOSING TO 20 SPM / 25%
 STROKE. ALSO CHANGE HYPO DOSING TO 30 SPM / 100%
 STROKE. THE REACTOR OVERFLOW VALVE TO THE

Inventory

Type	Check
H3PO4 Stock (gal)	
Sodium Hypo Stock (gal)	
Additional Field Test Kits Needed?	Dissolved Oxyge
	Nitrate + Nitrite
	Nitrite
	Sulfide
	Chlorine
Calibration kits needed?	o-Phosphate
	pH
	ORP
Turbidity	

Air Monitoring					
Zero Calibration? <input type="checkbox"/> Yes <input type="checkbox"/> No	Mixed Cylinder	Aeration Tank	MBFR 1	MBFR 2	OIT Area
Time					
Carbon Monoxide (ppm)					
Oxygen (%)					
Methane (% LEL)					
Hydrogen Sulfide (ppm)					

NOTES CONT.:
AERATION TANK WAS SLIGHTLY CLOSED TO COMPENSATE FOR LOWER FLOW AND MAINTAIN LEVEL IN THE MBFRS.

Date: 11/28/11

Time: 9:30

Operator: ARUCAN

Field Samples														
Calibration	pH calibration? <input checked="" type="checkbox"/> Yes <input type="checkbox"/> No Standards: <input type="checkbox"/> 4 <input type="checkbox"/> 7 <input type="checkbox"/> 10 Standard Reading: 4: <u>3.99</u> 7: <u>7.03</u> 10: <u>10.09</u>			ORP calibration? <input checked="" type="checkbox"/> Yes <input type="checkbox"/> No Temp (Deg C): <u>18.8</u> Standard Reading: 220: <u>211</u>			Turbidity calibration? <input checked="" type="checkbox"/> Yes <input type="checkbox"/> No Standards: <input type="checkbox"/> 0 <input type="checkbox"/> 20 <input type="checkbox"/> 200 <input type="checkbox"/> 1000 <input checked="" type="checkbox"/> 4000 Readings: 0.136: <u>0.186</u> 0.30: <u>0.353</u> 0.50: <u>0.612</u>							
	Lead Reactor: <input type="checkbox"/> MfBR1 <input checked="" type="checkbox"/> MfBR2 SP-100A <input checked="" type="checkbox"/> if MfBR1 in LEAD: SP-200B <input type="checkbox"/> if MfBR2 in LEAD: SP-100B <input checked="" type="checkbox"/>				Sample Collection Time: <u>12:00</u>									
Sample Data	Parameter	Units	Influent	*Lead Reactor	*Lag Reactor	Aeration	Media Filter Effluent	Post Sodium Hypo	Finished Water	GAC 1 Effluent	GAC 2 Effluent	IX 1 Effluent	Permitted Outfall	
	pH	(std units)	7.35	7.38	7.57	7.98	7.86		8.02				7.49	
	Temperature	(°C)	19.1	20.7	21.5	21.3	21.6		21.2				21.9	
	ORP	(mV)	340	-440	-553	-230	-20		585					
	Dissolved Oxygen	(mg/L)	8.5	0.3	0	5.5	6		7					
	Nitrate + Nitrite	(mg/L-N)	8.7	3.2	0.1				0.1					
	Nitrite	(mg/L-N)	0	1.1	0.1				0					
	Sulfide	(mg/L)	0	0	0.1	0			0					
	Turbidity	(NTU)	0.139			0.817	0.204		0.279					
	Chlorine Residual	(mg/L)						4.0	3.0					

* Signifies MfBR 1 or MfBR 2 depending on if reactor is in the lead or lag position - this changes every 96 hours

Note: shaded boxes are to remain blank

Post Finished Water System Inspection		
Collect while sump is running		
Bag Filter ΔP	psi	3
GAC-1 Pressure	psig	17
GAC-2 Pressure	psig	14
IX-1 Pressure	psig	13

Feed Tank Additions		
	H3PO4	Sodium Hypo
Time	1:00	1:05
Initial Tank Level (gal)	0.9	
Stock Added	250	
Type of Water Used For Dilution	INF	
Volume Dilution Added (gal)	4.0	
Total Volume Added (gal)	4.1	
Final Tank Level (gal)	5.0	

Note: There are 3785 mL per gallon.

Backwash Record		
Backwash start time:		
Backwash duration	min	
Initial Product Tank Level	gal	
Final Product Tank Level	gal	
Time of sample collection:		
Location	(NTU)	TSS Collected?
Lead Purge 1		<input type="checkbox"/> Yes <input type="checkbox"/> No
Lead Purge 2		<input type="checkbox"/> Yes <input type="checkbox"/> No
Lag Purge 1		<input type="checkbox"/> Yes <input type="checkbox"/> No
Lag Purge 2		<input type="checkbox"/> Yes <input type="checkbox"/> No
Media Filter		<input type="checkbox"/> Yes <input type="checkbox"/> No

NOTES:

STEADY STATE PHASE SINCE USER 11/23/11. CDM PERFORMED TURBIDITY CAL, ALL STANDARDS DO NOT READ WELL AND NEED TO BE REORDERED. CDM HAS CHANGED BAG FILTERS ON POST TREATMENT SYSTEM SPARGE OCCURED @ 2:00.

Inventory		
Type	Check	
H3PO4 Stock (gal)	4	
Sodium Hypo Stock (gal)	30	
Additional Field Test Kits Needed?	Dissolved Oxyge	5 + 8
	Nitrate + Nitrite	6
	Sulfide	3
	Chlorine	5
	o-Phosphate	3
Calibration kits needed?	pH	OK
	ORP	REORDER
	Turbidity	REORDER

Treatment System Inspection		
Outlet Totalizer	gal	7082/00
Target Flow Rate	gpm	8.0
Internal Recycle Rate	gpm	150/20
MfBR 1 pH	std units	7.2
MfBR 2 pH	std units	7.2
MfBR 1 ORP	mV	-514
MfBR 2 ORP	mV	-387
Nitrate Frequency	Hz	-
Last N Feed	ppm (N)	8.22
Last N R1	ppm (N)	0.04
Last N R2	ppm (N)	2.28
MfBR1 Sparge Rate	mm	240
MfBR2 Sparge Rate	mm	240
Phosphate Pump Settings	spm	20
	% stroke	25
Phosphate Concentration at Strainer	mg/LPO4	3.2
Aeration Tank Air Flow	scfm	3.2
Air Tank Pressure	psig	2.0
Target Media Filter Flow Rate	gpm	7.0
Media Filter Inlet Pressure	psig	9.9
Media Filter Outlet Pressure	psig	6.5*
Sodium Hypo Pump Settings	spm	30
	% stroke	100
Coagulant Tank Level	gal	4
Coagulant Pump Settings	ml/min	7
CO2 Cylinder Pressure	psi	88
H2 Cylinder Pressure	psi	91
N2 Pressure	psi	157
N2 Flow Rate	scfm	-
Turbidity (Instrument)	NTU	0.15
Turbidity (PRODUCT)	NTU	0.29

Air Monitoring					
Zero Calibration? <input type="checkbox"/> Yes <input type="checkbox"/> No	Mixed Cylinder	Aeration Tank	MBFR 1	MBFR 2	OIT Area
Time					
Carbon Monoxide (ppm)					
Oxygen (%)					
Methane (% LEL)					
Hydrogen Sulfide (ppm)					

NOTES CONT.:

CDM TO ORDER MORE POST-FILTERS (250-100). CDM INSTALLED 100-50 TYPE FILTER. NEED
 TO CLOSELY MONITOR IP. APT ONSITE TO REFILL FILTER AID AND HARVEST 2 FE FIBER
 REACTORS (1 FROM EACH MBFR)

Date: 11/30/11

Time: 10AM

Operator: BEROKOFF

Field Samples													
Calibration	pH calibration? <input checked="" type="checkbox"/> Yes <input type="checkbox"/> No Standards: <input checked="" type="checkbox"/> 4 <input checked="" type="checkbox"/> 7 <input type="checkbox"/> 10 Standard Reading: 4: <u>4.00</u> 7: <u>7.04</u> 10: <u>10.10</u>			ORP calibration? <input type="checkbox"/> Yes <input type="checkbox"/> No Temp (Deg C): <u>14</u> Standard Reading: 220: <u>220</u>			Turbidity calibration? <input checked="" type="checkbox"/> Yes <input type="checkbox"/> No Standards: <input type="checkbox"/> 0 <input checked="" type="checkbox"/> 20 <input type="checkbox"/> 200 <input type="checkbox"/> 1000 <input type="checkbox"/> 4000 Readings: 0.136: - 0.30: - 0.50: -						
	Lead Reactor: <input checked="" type="checkbox"/> MIBR1 <input type="checkbox"/> MIBR2 <input type="checkbox"/> SP-100A <input checked="" type="checkbox"/> SP-200B <input type="checkbox"/> SP-100B			Lag Reactor: <input type="checkbox"/> MIBR1 <input type="checkbox"/> MIBR2 <input type="checkbox"/> SP-100A <input type="checkbox"/> SP-200B <input type="checkbox"/> SP-100B			Sample Collection Time: <u>10:30</u>						
Sample Data	Parameter	Units	Influent	*Lead Reactor	*Lag Reactor	Aeration	Media Filter Effluent	Post Sodium Hypo	Finished Water	GAC 1 Effluent	GAC 2 Effluent	IX 1 Effluent	Permitted Outfall
	pH	(std units)	7.55	7.60	7.41	7.84	7.72		7.90				7.45
	Temperature	(°C)	19.2	20.1	21.3	21.2	21.2		21.0				20.8
	ORP	(mV)	372	-453	-501	-156	55		640				
	Dissolved Oxygen	(mg/L)	9	0.35	0	7	5.5		7.0				
	Nitrate + Nitrite	(mg/L-N)	9	2.2	0				0.4				
	Nitrite	(mg/L-N)	0	0.6	0				0				
	Sulfide	(mg/L)	0	0	0.3	0.1			0				
	Turbidity	(NTU)					0.211						
	Chlorine Residual	(mg/L)						2.0	1.5				

* Signifies MIBR 1 or MIBR 2 depending on if reactor is in the lead or lag position - this changes every 96 hours

Note: shaded boxes are to remain blank

Treatment System Inspection		
Outlet Totalizer	gal	7108600
Target Flow Rate	gpm	8
Internal Recycle Rate	gpm	150/180
MBfR 1 pH	std units	7.2
MBfR 2 pH	std units	7.2
MBfR 1 ORP	mV	-309
MBfR 2 ORP	mV	-719
Nitrate Frequency	Hz	-
Last N Feed	ppm (N)	8.24
Last N R1	ppm (N)	1.73
Last N R2	ppm (N)	0
MBfR1 Sparge Rate	mm	240
MBfR2 Sparge Rate	mm	240
Phosphate Pump Settings	spm	30
	% stroke	35
Phosphate Concentration at Strainer	mg/LPO4	
Aeration Tank Air Flow	scfm	3.2
Air Tank Pressure	psig	2.0
Target Media Filter Flow Rate	gpm	6
Media Filter Inlet Pressure	psig	2.9
Media Filter Outlet Pressure	psig	1.3
Sodium Hypo Pump Settings	spm	30
	% stroke	100
Coagulant Tank Level	gal	0
Coagulant Pump Settings	ml/min	7
CO2 Cylinder Pressure	psi	87
H2 Cylinder Pressure	psi	88
N2 Pressure	psi	168
N2 Flow Rate	scfm	-
Turbidity (Instrument)	NTU	0.23
Turbidity (OIT)	NTU	0.40

Post Finished Water System Inspection		
Collect while sump is running		
Bag Filter ΔP	psi	3
GAC-1 Pressure	psig	14
GAC-2 Pressure	psig	10
IX-1 Pressure	psig	1.3

Feed Tank Additions		
	H3PO4	Sodium Hypo
Time	12PM	12PM
Initial Tank Level (gal)	3.5	15
Stock Added	-	-
Type of Water Used For Dilution	-	-
Volume Dilution Added (gal)	-	-
Total Volume Added (gal)	-	-
Final Tank Level (gal)	3.5	15

Note: There are 3785 mL per gallon.

Backwash Record		
Backwash start time:	1:10PM	
Backwash duration	min	
Initial Product Tank Level	gal	
Final Product Tank Level	gal	
Time of sample collection:		
Location	(NTU)	TSS Collected?
Lead Purge 1		<input type="checkbox"/> Yes <input checked="" type="checkbox"/> No
Lead Purge 2		<input type="checkbox"/> Yes <input checked="" type="checkbox"/> No
Lag Purge 1		<input type="checkbox"/> Yes <input checked="" type="checkbox"/> No
Lag Purge 2		<input type="checkbox"/> Yes <input checked="" type="checkbox"/> No
Media Filter		<input type="checkbox"/> Yes <input checked="" type="checkbox"/> No

NOTES:

INCREASED PHOSPHATE DOSING PUMP STROKE LENGTH FROM 25% TO 30%. COAGULANT TANK WAS EMPTY UPON ARRIVAL, CDM TURNED OFF DOSING PUMP AND ALERTED APT. CDM TURNED DOWN CL2 PUMP TO 25SPM (FROM 30) DUE TO THE LOWER MEDIA FILTER RATE.
 B-104^{flow}

Inventory		
Type	Check	
H3PO4 Stock (gal)	4	
Sodium Hypo Stock (gal)	30	
Additional Field Test Kits Needed?	Dissolved Oxygen	5+8
	Nitrate + Nitrite	6
	Nitrite	6
	Sulfide	3
	Chlorine	3
	o-Phosphate	3
Calibration kits needed?	pH	✓
	ORP	ORDER
	Turbidity	ORDER

Air Monitoring					
Zero Calibration? <input type="checkbox"/> Yes <input type="checkbox"/> No	Mixed Cylinder	Aeration Tank	MBFR 1	MBFR 2	OIT Area
Time					
Carbon Monoxide (ppm)					
Oxygen (%)					
Methane (% LEL)					
Hydrogen Sulfide (ppm)					

NOTES CONT:

COLLECTED 10 GAL INFLUENT WELL WATER + 5 GAL FLUSH (PURGE) WATER → OVERNIGHTED THESE TO ASU. CDM HAD TO MANUALLY INITIATE A SPARGE ON MBFR AND ONLY COLLECTE SAMPLE WATER DURING THE FIRST DRAIN/SECOND DRAIN FOR BOTH REACTORS.

Date: 12/2/11

Time: 1:00pm

Operator: BEROKOFF

Field Samples

Calibration	pH calibration? <input type="checkbox"/> Yes <input type="checkbox"/> No Standards: <input type="checkbox"/> 4 <input type="checkbox"/> 7 <input type="checkbox"/> 10 Standard Reading: 4: _____ 7: _____ 10: _____		ORP calibration? <input type="checkbox"/> Yes <input type="checkbox"/> No Temp (Deg C): _____ Standard Reading: 220: _____		Turbidity calibration? <input type="checkbox"/> Yes <input type="checkbox"/> No Standards: <input type="checkbox"/> 0 <input type="checkbox"/> 20 <input type="checkbox"/> 200 <input type="checkbox"/> 1000 <input type="checkbox"/> 4000 Readings: 0.136: _____ 0.30: _____ 0.50: _____								
	Lead Reactor: <input type="checkbox"/> MBfR1 <input type="checkbox"/> MBfR2 SP-100A <input type="checkbox"/>		Lag Sample <input type="checkbox"/> if MBfR1 in LEAD: SP-200B <input type="checkbox"/> if MBfR2 in LEAD: SP-100B <input type="checkbox"/>		Sample Collection Time: <u>1:30pm</u>								
Sample Data	Parameter	Units	Influent	*Lead Reactor	*Lag Reactor	Aeration	Media Filter Effluent	Post Sodium Hypo	Finished Water	GAC 1 Effluent	GAC 2 Effluent	IX 1 Effluent	Permitted Outfall
	pH	(std units)											
	Temperature	(°C)											
	ORP	(mV)											
	Dissolved Oxygen	(mg/L)											
	Nitrate + Nitrite	(mg/L-N)											
	Nitrite	(mg/L-N)											
	Sulfide	(mg/L)			<u>2.5</u>								
	Turbidity	(NTU)								<u>1.5</u>			
	Chlorine Residual	(mg/L)											

* Signifies MBfR 1 or MBfR 2 depending on if reactor is in the lead or lag position - this changes every 96 hours

Note: shaded boxes are to remain blank

Treatment System Inspection

Outlet Totalizer	gal	
Target Flow Rate	gpm	<u>6</u>
Internal Recycle Rate	gpm	
MBfR 1 pH	std units	
MBfR 2 pH	std units	
MBfR 1 ORP	mV	
MBfR 2 ORP	mV	
Nitrate Frequency	Hz	
Last N Feed	ppm (N)	
Last N R1	ppm (N)	
Last N R2	ppm (N)	
MBfR1 Sparge Rate	mm	
MBfR2 Sparge Rate	mm	
Phosphate Pump Settings	spm % stroke	<u>30 30</u>
Phosphate Concentration at Strainer	mg/LPO4	
Aeration Tank Air Flow	scfm	
Air Tank Pressure	psig	
Target Media Filter Flow Rate	gpm	
Media Filter Inlet Pressure	psig	
Media Filter Outlet Pressure	psig	
Sodium Hypo Pump Settings	spm % stroke	<u>25 100</u>
Coagulant Tank Level	gal	<u>0</u>
Coagulant Pump Settings	ml/min	<u>0</u>
CO2 Cylinder Pressure	psi	
H2 Cylinder Pressure	psi	<u>70</u>
N2 Pressure	psi	
N2 Flow Rate	scfm	
Turbidity (Instrument)	NTU	
Turbidity (OIT)	NTU	

Post Finished Water System Inspection

Collect while sump is running

Bag Filter ΔP	psi	
GAC-1 Pressure	psig	
GAC-2 Pressure	psig	
IX-1 Pressure	psig	

Feed Tank Additions

	H3PO4	Sodium Hypo
Time	<u>1:30pm</u>	<u>1:30pm</u>
Initial Tank Level (gal)	<u>1.8</u>	<u>12</u>
Stock Added	<u>130</u>	<u>1 gal</u>
Type of Water Used For Dilution	<u>INF</u>	<u>MEDIA FILTER</u>
Volume Dilution Added (gal)	<u>3.2</u>	<u>17</u>
Total Volume Added (gal)	<u>3.2</u>	<u>18</u>
Final Tank Level (gal)	<u>5</u>	<u>30</u>

Note: There are 3785 mL per gallon.

Backwash Record

Backwash start time:		
Backwash duration	min	
Initial Product Tank Level	gal	
Final Product Tank Level	gal	
Time of sample collection:		
Location	(NTU)	TSS Collected?
Lead Purge 1		<input type="checkbox"/> Yes <input type="checkbox"/> No
Lead Purge 2		<input type="checkbox"/> Yes <input type="checkbox"/> No
Lag Purge 1		<input type="checkbox"/> Yes <input type="checkbox"/> No
Lag Purge 2		<input type="checkbox"/> Yes <input type="checkbox"/> No
Media Filter		<input type="checkbox"/> Yes <input type="checkbox"/> No

NOTES:

NO SAMPLING TODAY. CDM ON SITE TO TOP OF H3PO4 AND SODIUM HYPO TANKS. CDM RESTARTED H2 GENERATOR AND VERIFIED ENOUGH H2 IN G-PACK TO LAST THROUGH THE WEEKEND IF GENERATOR SHUTS DOWN AGAIN.

Inventory

Type	Check
H3PO4 Stock (gal)	
Sodium Hypo Stock (gal)	
Additional Field Test Kits Needed?	Dissolved Oxygen
	Nitrate + Nitrite
	Nitrite
	Sulfide
	o-Phosphate
Calibration kits needed?	pH
	ORP
	Turbidity

Air Monitoring

Zero Calibration? <input type="checkbox"/> Yes <input type="checkbox"/> No	Mixed Cylinder	Aeration Tank	MBfR 1	MBfR 2	OIT Area
Time					
Carbon Monoxide (ppm)					
Oxygen (%)					
Methane (% LEL)					
Hydrogen Sulfide (ppm)					

NOTES CONT.:

INCREASED SODIUM HYPO PUMP ^{SPM} SETTINGS TO 30 (FROM 25 SPM) AFTER ~~FILLING~~ TOPPING OFF TANK. APT TO BE ON SITE THIS AFTERNOON TO ADJUST BALL VALVE SETTING ON MBfR OUTFALL (OVERFLOW TO AERATION) TO ACCOUNT FOR LOWERED FLOW RATE (6 GPM). CDM ADJUSTED BALL VALVE (APT - TO CHECK ON WATER LEVEL LATER TODAY). NOTICED SOME KNOCKING OR ROUGHER SOUNDS FROM SUMP PUMP (MIGHT CONSIDER SERVICING IT).

Date: 12/5/11

Time: 8:40AM

Operator: BERCKOFF

Field Samples													
Calibration	pH calibration? <input type="checkbox"/> Yes <input checked="" type="checkbox"/> No Standards: <input type="checkbox"/> 4 <input type="checkbox"/> 7 <input type="checkbox"/> 10 Standard Reading: 4: _____ 7: <u>7.02</u> 10: _____				ORP calibration? <input type="checkbox"/> Yes <input type="checkbox"/> No Temp (Deg C): _____ Standard Reading: 220: _____				Turbidity calibration? <input type="checkbox"/> Yes <input type="checkbox"/> No Standards: <input type="checkbox"/> 0 <input type="checkbox"/> 20 <input type="checkbox"/> 200 <input type="checkbox"/> 1000 <input type="checkbox"/> 4000 Readings: 0.136: _____ 0.30: _____ 0.50: _____				
	Lead Sample <input type="checkbox"/> Lag Sample <input type="checkbox"/> Lead Reactor: <input type="checkbox"/> MIBR1 <input type="checkbox"/> MIBR2 <input type="checkbox"/> SP-100A <input type="checkbox"/> if MIBR1 in LEAD: SP-200B <input type="checkbox"/> if MIBR2 in LEAD: SP-100B <input type="checkbox"/> Sample Collection Time: <u>9:30AM</u>												
Sample Data	Parameter	Units	Influent	*Lead Reactor	*Lag Reactor	Aeration	Media Filter Effluent	Post Sodium Hypo	Finished Water	GAC 1 Effluent	GAC 2 Effluent	IX 1 Effluent	Permitted Outfall
	pH	(std units)											7.37
	Temperature	(°C)											17.5
	ORP	(mV)											
	Dissolved Oxygen	(mg/L)											
	Nitrate + Nitrite	(mg/L-N)											
	Nitrite	(mg/L-N)											
	Sulfide	(mg/L)											
	Turbidity	(NTU)											
	Chlorine Residual	(mg/L)											

* Signifies MBFR 1 or MBFR 2 depending on if reactor is in the lead or lag position - this changes every 96 hours

Note: shaded boxes are to remain blank

Treatment System Inspection		
Outlet Totalizer	gal	7153300
Target Flow Rate	gpm	6
Internal Recycle Rate	gpm	
MBFR 1 pH	std units	
MBFR 2 pH	std units	
MBFR 1 ORP	mV	
MBFR 2 ORP	mV	
Nitrate Frequency	Hz	
Last N Feed	ppm (N)	
Last N R1	ppm (N)	
Last N R2	ppm (N)	
MBFR1 Sparge Rate	mm	
MBFR2 Sparge Rate	mm	
Phosphate Pump Settings	spm % stroke	
Phosphate Concentration at Strainer	mg/LPO4	
Aeration Tank Air Flow	scfm	
Air Tank Pressure	psig	
Target Media Filter Flow Rate	gpm	
Media Filter Inlet Pressure	psig	
Media Filter Outlet Pressure	psig	
Sodium Hypo Pump Settings	spm % stroke	
Coagulant Tank Level	gal	
Coagulant Pump Settings	ml/min	
CO2 Cylinder Pressure	psi	
H2 Cylinder Pressure	psi	
N2 Pressure	psi	
N2 Flow Rate	scfm	
Turbidity (Instrument)	NTU	
Turbidity (OIT)	NTU	

Post Finished Water System Inspection		
Collect while sump is running		
Bag Filter ΔP	psi	2
GAC-1 Pressure	psig	
GAC-2 Pressure	psig	
IX-1 Pressure	psig	

Backwash Record		
Backwash start time: _____		
Backwash duration	min	
Initial Product Tank Level	gal	
Final Product Tank Level	gal	
Time of sample collection:		
Location	(NTU)	TSS Collected?
Lead Purge 1		<input type="checkbox"/> Yes <input type="checkbox"/> No
Lead Purge 2		<input type="checkbox"/> Yes <input type="checkbox"/> No
Lag Purge 1		<input type="checkbox"/> Yes <input type="checkbox"/> No
Lag Purge 2		<input type="checkbox"/> Yes <input type="checkbox"/> No
Media Filter		<input type="checkbox"/> Yes <input type="checkbox"/> No

Inventory	
Type	Check
H3PO4 Stock (gal)	
Sodium Hypo Stock (gal)	
Additional Field Test Kits Needed?	Dissolved Oxyge
	Nitrate + Nitrite
	Nitrite
	Sulfide
	Chlorine
Calibration kits needed?	o-Phosphate
	pH
	ORP
	Turbidity

Feed Tank Additions		
	H3PO4	Sodium Hypo
Time	10AM	
Initial Tank Level (gal)	2.75	
Stock Added	100.001	
Type of Water Used For Dilution	INF	
Volume Dilution Added (gal)	2.25	
Total Volume Added (gal)	2.25	
Final Tank Level (gal)	5	

NOTES:
 NO SAMPLING TODAY DUE TO RUNNING OUT OF H2 OVER THE WEEKEND. CAMERON TO DELIVER NEW 6-PACK LATER TODAY. CURRENTLY ONLY RUNNING ON ONE CYLINDER (400PSI). CDM TO COORDINATE W/APT TO SEE IF RICH BUDAY WILL BE ON SITE LATER TODAY AND SWITCH OUT REGULATOR TO NEW 6-PACK. CAMERON TO DELIVER ANOTHER 6-PACK ON 12/5/11.

Note: There are 3785 mL per gallon.

Air Monitoring					
Zero Calibration? <input type="checkbox"/> Yes <input type="checkbox"/> No	Mixed Cylinder	Aeration Tank	MBfR 1	MBfR 2	OIT Area
Time					
Carbon Monoxide (ppm)					
Oxygen (%)					
Methane (% LEL)					
Hydrogen Sulfide (ppm)					

NOTES CONT.:

THERE WAS A SIZABLE LEAK THAT OCCURRED ON THE N₂ SPARGE LINE JUST PRIOR TO THE SOLONOID VALVES. CDM ~~TH~~ TIGHTENED IT UP AND MINIMIZED LEAK - BUT REQUIRES FURTHER MAINTENANCE AND POSSIBLE REPAIR (CDM ALERTED APT). CAMERON TO FILL N₂ DEWAR TODAY AS THE LEAK LIKELY CAUSED ~~THE~~ US TO RUN OUT OF N₂. CDM CLOSED OFF VALVE ON N₂ DEWAR ~~SO~~ TO PREVENT FURTHER LOSS ON GAS UPON FILLING UP THE DEWAR TODAY (~12pm).

Date: 12/9/11

Time: 12:00

Operator: ARUCAN

Field Samples													
Calibration	pH calibration? <input type="checkbox"/> Yes <input checked="" type="checkbox"/> No Standards: <input type="checkbox"/> 4 <input type="checkbox"/> 7 <input type="checkbox"/> 10 Standard Reading: 4: _____ 7: _____ 10: _____				ORP calibration? <input type="checkbox"/> Yes <input checked="" type="checkbox"/> No Temp (Deg C): _____ Standard Reading: 220: _____				Turbidity calibration? <input type="checkbox"/> Yes <input checked="" type="checkbox"/> No Standards: <input type="checkbox"/> 0 <input type="checkbox"/> 20 <input type="checkbox"/> 200 <input type="checkbox"/> 1000 <input type="checkbox"/> 4000 Readings: 0.136: _____ 0.30: _____ 0.50: _____				
	Lead Reactor: <input checked="" type="checkbox"/> MBR1 <input type="checkbox"/> MBR2 Lag Sample: <input type="checkbox"/> if MBfR1 in LEAD: SP-200B <input type="checkbox"/> if MBfR2 in LEAD: SP-100B <input type="checkbox"/> Sample Collection Time: 12:00												
Sample Data	Parameter	Units	Influent	*Lead Reactor	*Lag Reactor	Aeration	Media Filter Effluent	Post Sodium Hypo	Finished Water	GAC 1 Effluent	GAC 2 Effluent	IX 1 Effluent	Permitted Outfall
	pH	(std units)											7.19
	Temperature	(°C)											20.3
	ORP	(mV)											
	Dissolved Oxygen	(mg/L)											
	Nitrate + Nitrite	(mg/L-N)											
	Nitrite	(mg/L-N)											
	Sulfide	(mg/L)											
	Turbidity	(NTU)											
	Chlorine Residual	(mg/L)											

* Signifies MBfR 1 or MBfR 2 depending on if reactor is in the lead or lag position - this changes every 96 hours

Note: shaded boxes are to remain blank

Treatment System Inspection		
Outlet Totalizer	gal	7189400
Target Flow Rate	gpm	6.0
Internal Recycle Rate	gpm	150/120
MBfR 1 pH	std units	7.2
MBfR 2 pH	std units	7.2
MBfR 1 ORP	mV	-332
MBfR 2 ORP	mV	-698
Nitrate Frequency	Hz	—
Last N Feed	ppm (N)	8.25
Last N R1	ppm (N)	1.30
Last N R2	ppm (N)	0.18
MBfR1 Sparge Rate	mm	240
MBfR2 Sparge Rate	mm	240
Phosphate Pump Settings	spm	20
	% stroke	30
Phosphate Concentration at Strainer	mg/LPO4	—
Aeration Tank Air Flow	scfm	3.2
Air Tank Pressure	psig	2.0
Target Media Filter Flow Rate	gpm	5
Media Filter Inlet Pressure	psig	2.0
Media Filter Outlet Pressure	psig	4.9
Sodium Hypo Pump Settings	spm	30
	% stroke	100
Coagulant Tank Level	gal	0
Coagulant Pump Settings	ml/min	OFF
CO2 Cylinder Pressure	psi	88
H2 Cylinder Pressure	psi	90
N2 Pressure	psi	—
N2 Flow Rate	scfm	123
Turbidity (Instrument)	NTU	0.25
Turbidity (OIT)	NTU	0.26

Post Finished Water System Inspection		
Collect while sump is running		
Bag Filter ΔP	psi	2
GAC-1 Pressure	psig	14
GAC-2 Pressure	psig	12.5
IX-1 Pressure	psig	1.5

Backwash Record		
Backwash start time:		
Backwash duration	min	
Initial Product Tank Level	gal	
Final Product Tank Level	gal	
Time of sample collection:		
Location	(NTU)	TSS Collected?
Lead Purge 1		<input type="checkbox"/> Yes <input type="checkbox"/> No
Lead Purge 2		<input type="checkbox"/> Yes <input type="checkbox"/> No
Lag Purge 1		<input type="checkbox"/> Yes <input type="checkbox"/> No
Lag Purge 2		<input type="checkbox"/> Yes <input type="checkbox"/> No
Media Filter		<input type="checkbox"/> Yes <input type="checkbox"/> No

NOTES:
 CDM ON SITE TO TAKE WEEKLY COMPLIANCE SAMPLES
 SPARGE OCCURRED @ 1:00 PM.

Feed Tank Additions		
	H3PO4	Sodium Hypo
Time	1:00	1:10
Initial Tank Level (gal)	1.5	15
Stock Added	175 → 375	—
Type of Water Used For Dilution	INFL.	—
Volume Dilution Added (gal)	3.5	—
Total Volume Added (gal)	3.5	0
Final Tank Level (gal)	5.0	15

Note: There are 3785 mL per gallon.

Date: 12/14/11

Time: 9:30

Operator: ARUCAN

Field Samples

Calibration: pH calibration? Yes No
 Standards: 4 7 10
 Standard Reading: 4: 4.02 7: 7.01 10: 10.06
 ORP calibration? Yes No
 Temp (Deg C): 17.1
 Standard Reading: 220: 216
 Turbidity calibration? Yes No
 Standards: 0 20 200 1000 4000
 Readings: 0.136: 0.149 0.30: 0.316 0.50: 0.521

Lead Sample Lag Sample
 Lead Reactor: MBR1 MBR2
 SP-100A if MBR1 in LEAD: SP-200B
 if MBR2 in LEAD: SP-100B
 Sample Collection Time: 11:45

Parameter	Units	Influent	*Lead Reactor	*Lag Reactor	Aeration	Media Filter Effluent	Post Sodium Hypo	Finished Water	GAC 1 Effluent	GAC 2 Effluent	IX 1 Effluent	Permitted Outfall
pH	(std units)	7.21	7.62	7.49	7.88	7.75		7.82				7.26
Temperature	(°C)	17.9	19.2	19.8	19.8	19.5		18.6				18.7
ORP	(mV)	70	-506	-541	-276	-160		500				
Dissolved Oxygen	(mg/L)	9	0.4	0	6	7		7.5				
Nitrate + Nitrite	(mg/L-N)	8.2	2.4	0.4				0				
Nitrite	(mg/L-N)	0	0.6	0				0				
Sulfide	(mg/L)	0	0	0.5	0.3			0				
Turbidity	(NTU)											
Chlorine Residual	(mg/L)							0.4	0.2			

* Signifies MBR 1 or MBR 2 depending on if reactor is in the lead or lag position - this changes every 96 hours

Treatment System Inspection

Outlet Totalizer	gal	7226000
Target Flow Rate	gpm	6.0
Internal Recycle Rate	gpm	150/120
MBfR 1 pH	std units	7.2
MBfR 2 pH	std units	7.2
MBfR 1 ORP	mV	-292
MBfR 2 ORP	mV	-661
Nitrate Frequency	Hz	—
Last N Feed	ppm (N)	8.03
Last N R1	ppm (N)	1.62
Last N R2	ppm (N)	0.24
MBfR1 Sparge Rate	mm	240
MBfR2 Sparge Rate	mm	240
Phosphate Pump Settings	spm	20
	% stroke	30
Phosphate Concentration at Strainer	mg/LPO4	
Aeration Tank Air Flow	scfm	3.2
Air Tank Pressure	psig	2
Target Media Filter Flow Rate	gpm	5.0
Media Filter Inlet Pressure	psig	2.5
Media Filter Outlet Pressure	psig	1.5
Sodium Hypo Pump Settings	spm	30
	% stroke	100
Coagulant Tank Level	gal	17
Coagulant Pump Settings	ml/min	5
CO2 Cylinder Pressure	psi	88
H2 Cylinder Pressure	psi	91
N2 Pressure	psi	123
N2 Flow Rate	scfm	—
Turbidity (Instrument)	NTU	0.20
Turbidity (OIT)	NTU	0.20

Post Finished Water System Inspection *

Collect while sump is running

Bag Filter ΔP	psi	4
GAC-1 Pressure	psig	5
GAC-2 Pressure	psig	13
IX-1 Pressure	psig	1

Feed Tank Additions

	H3PO4	Sodium Hypo
Time	11:15	11:30
Initial Tank Level (gal)	0.5	8
Stock Added	220	0
Type of Water Used For Dilution	INF	N/A
Volume Dilution Added (gal)	4.5	0
Total Volume Added (gal)	5.0	0
Final Tank Level (gal)	5.0	8

Note: There are 3785 mL per gallon.

Backwash Record

Backwash start time: _____
 Backwash duration: _____ min
 Initial Product Tank Level: _____ gal
 Final Product Tank Level: _____ gal
 Time of sample collection: _____

Location	(NTU)	TSS Collected?
Lead Purge 1		<input type="checkbox"/> Yes <input type="checkbox"/> No
Lead Purge 2		<input type="checkbox"/> Yes <input type="checkbox"/> No
Lag Purge 1		<input type="checkbox"/> Yes <input type="checkbox"/> No
Lag Purge 2		<input type="checkbox"/> Yes <input type="checkbox"/> No
Media Filter		<input type="checkbox"/> Yes <input type="checkbox"/> No

NOTES:

CDM ON-SITE TO PUMP REMAINING WATER IN SECONDARY CONTAINMENT.
 THE TURBIDITY METER WAS UNPLUGGED FROM 10:00 - 11:00 TO USE ITS POWER SUPPLY. CDM INSTALLED HOSE CHAMPS IN AREAS THAT REQ. IN THE IX/GAC TANKER. TURBIDITY SAMPLES WERE NOT TAKEN DUE TO SPARGE @ 1:00.

Air Monitoring					
Zero Calibration? <input type="checkbox"/> Yes <input type="checkbox"/> No	Mixed Cylinder	Aeration Tank	MBFR 1	MBFR 2	OIT Area
Time					
Carbon Monoxide (ppm)					
Oxygen (%)					
Methane (% LEL)					
Hydrogen Sulfide (ppm)					

NOTES CONT.:
CDM CHECKED LEVEL AND HEIGHT OF SECONDARY CONTAINMENT SWITCH. IT WILL ENGAGE AT APPROX. 5'-6" FROM BOTTOM.
* SUMP PUMP PRESSURE: 31 PSI

Date: 12/15/11

Time: 10:00

Operator: _____

Field Samples													
Calibration	pH calibration? <input type="checkbox"/> Yes <input type="checkbox"/> No Standards: <input type="checkbox"/> 4 <input type="checkbox"/> 7 <input type="checkbox"/> 10 Standard Reading: 4: _____ 7: _____ 10: _____			ORP calibration? <input type="checkbox"/> Yes <input type="checkbox"/> No Temp (Deg C): _____ Standard Reading: 220: _____			Turbidity calibration? <input type="checkbox"/> Yes <input type="checkbox"/> No Standards: <input type="checkbox"/> 0 <input type="checkbox"/> 20 <input type="checkbox"/> 200 <input type="checkbox"/> 1000 <input type="checkbox"/> 4000 Readings: 0.136: _____ 0.30: _____ 0.50: _____						
	Lead Reactor: <input type="checkbox"/> MBR1 <input type="checkbox"/> MBR2 <input type="checkbox"/> SP-100A <input type="checkbox"/> if MBR1 in LEAD: SP-200B <input type="checkbox"/> if MBR2 in LEAD: SP-100B <input type="checkbox"/>			Sample Collection Time: _____									
Sample Data	Parameter	Units	Influent	*Lead Reactor	*Lag Reactor	Aeration	Media Filter Effluent	Post Sodium Hypo	Finished Water	GAC 1 Effluent	GAC 2 Effluent	IX 1 Effluent	Permitted Outfall
	pH	(std units)											
	Temperature	(°C)											
	ORP	(mV)											
	Dissolved Oxygen	(mg/L)											
	Nitrate + Nitrite	(mg/L-N)											
	Nitrite	(mg/L-N)											
	Sulfide	(mg/L)											
	Turbidity	(NTU)											
	Chlorine Residual	(mg/L)											

* Signifies MBR 1 or MBR 2 depending on if reactor is in the lead or lag position - this changes every 96 hours

Note: shaded boxes are to remain blank

Post Finished Water System Inspection		
Collect while sump is running *		
Bag Filter ΔP	psi	3
GAC-1 Pressure	psig	5.5
GAC-2 Pressure	psig	4.5
IX-1 Pressure	psig	1

Backwash Record		
Backwash start time: _____		
Backwash duration	min	
Initial Product Tank Level	gal	
Final Product Tank Level	gal	
Time of sample collection:		
Location	(NTU)	TSS Collected?
Lead Purge 1		<input type="checkbox"/> Yes <input type="checkbox"/> No
Lead Purge 2		<input type="checkbox"/> Yes <input type="checkbox"/> No
Lag Purge 1		<input type="checkbox"/> Yes <input type="checkbox"/> No
Lag Purge 2		<input type="checkbox"/> Yes <input type="checkbox"/> No
Media Filter		<input type="checkbox"/> Yes <input type="checkbox"/> No

NOTES:
 CDM ON SITE TO BYPASS GAC 1 (LEAD) AND REPOSE GAC 2 TO THE LEAD POSITION. GAC 1 WILL BE ISOLATED FROM THE SYSTEM. PRESSURES BEFORE CHANGE ARE ON BACK.

Inventory	
Type	Check
H3PO4 Stock (gal)	
Sodium Hypo Stock (gal)	
Additional Field Test Kits Needed?	Dissolved Oxygen
	Nitrate + Nitrite
	Nitrite
	Sulfide
	Chlorine
Calibration kits needed?	o-Phosphate
	pH
	ORP
	Turbidity

Treatment System Inspection		
Outlet Totalizer	gal	
Target Flow Rate	gpm	
Internal Recycle Rate	gpm	
MBfR 1 pH	std units	
MBfR 2 pH	std units	
MBfR 1 ORP	mV	
MBfR 2 ORP	mV	
Nitrate Frequency	Hz	
Last N Feed	ppm (N)	
Last N R1	ppm (N)	
Last N R2	ppm (N)	
MBfR1 Sparge Rate	mm	
MBfR2 Sparge Rate	mm	
Phosphate Pump Settings	spm % stroke	
Phosphate Concentration at Strainer	mg/LPO4	
Aeration Tank Air Flow	scfm	
Air Tank Pressure	psig	
Target Media Filter Flow Rate	gpm	
Media Filter Inlet Pressure	psig	
Media Filter Outlet Pressure	psig	
Sodium Hypo Pump Settings	spm % stroke	
Coagulant Tank Level	gal	
Coagulant Pump Settings	ml/min	
CO2 Cylinder Pressure	psi	
H2 Cylinder Pressure	psi	
N2 Pressure	psi	
N2 Flow Rate	scfm	
Turbidity (Instrument)	NTU	
Turbidity (OIT)	NTU	

Feed Tank Additions		
	H3PO4	Sodium Hypo
Time		
Initial Tank Level (gal)		
Stock Added		
Type of Water Used For Dilution		
Volume Dilution Added (gal)		
Total Volume Added (gal)		
Final Tank Level (gal)		

Note: There are 3785 mL per gallon.

* SUMP DISCHARGE PRESSURE = 10 PSI

Air Monitoring					
Zero Calibration? <input type="checkbox"/> Yes <input type="checkbox"/> No	Mixed Cylinder	Aeration Tank	MBIR 1	MBIR 2	OIT Area
Time					
Carbon Monoxide (ppm)					
Oxygen (%)					
Methane (% LEL)					
Hydrogen Sulfide (ppm)					

SAMP DISCHARGE : 31
 BAG ID : 3
 GAC 1 : 5
 GAC 2 : 3
 K 2 : 1

NOTES CONT.:

Date: 12/16/11

Time: 9:00

Operator: ARUCAN

Field Samples												
Calibration	pH calibration? <input checked="" type="checkbox"/> Yes <input type="checkbox"/> No Standards: <input checked="" type="checkbox"/> 4 <input checked="" type="checkbox"/> 7 <input type="checkbox"/> 10 Standard Reading: <input checked="" type="checkbox"/> 4: <input type="checkbox"/> 7: <input type="checkbox"/> 10:			ORP calibration? <input checked="" type="checkbox"/> Yes <input type="checkbox"/> No Temp (Deg C): 18.1 Standard Reading: 220: 217			Turbidity calibration? <input type="checkbox"/> Yes <input checked="" type="checkbox"/> No Standards: <input type="checkbox"/> 0 <input type="checkbox"/> 20 <input type="checkbox"/> 200 <input type="checkbox"/> 1000 <input type="checkbox"/> 4000 Readings: 0.136: 0.30: 0.50:					
	Lead Sample <input type="checkbox"/> Lag Sample <input type="checkbox"/>				Sample Collection Time: 12:00							
Lead Reactor: <input type="checkbox"/> MfBR1 <input type="checkbox"/> MfBR2 SP-100A <input type="checkbox"/> if MfBR1 in LEAD: SP-200B <input type="checkbox"/> if MfBR2 in LEAD: SP-100B <input type="checkbox"/>												
Parameter	Units	Influent	*Lead Reactor	*Lag Reactor	Aeration	Media Filter Effluent	Post Sodium Hypo	Finished Water	GAC 1 Effluent	GAC 2 Effluent	IX 1 Effluent	Permitted Outfall
pH	(std units)	7.27	7.55	7.47	7.91	7.71		7.81				7.58
Temperature	(°C)	17.7	18.8	19.6	19.3	19.0		17.8				17.5
ORP	(mV)	50	-440	-490	-220	-140		510				
Dissolved Oxygen	(mg/L)	8	0.6	0.1	5.5	6		7				
Nitrate + Nitrite	(mg/L-N)	8.2	1.7	0				0				
Nitrite	(mg/L-N)	0	0	0				0				
Sulfide	(mg/L)	0*	0*	0.8*	0.6*			0*				
Turbidity	(NTU)	—*			1.21*			—*				
Chlorine Residual	(mg/L)						*	0.6				

* Signifies MBfR 1 or MBfR 2 depending on if reactor is in the lead or lag position - this changes every 96 hours

Note: shaded boxes are to remain blank

Treatment System Inspection		
Outlet Totalizer	gal	724400
Target Flow Rate	gpm	6
Internal Recycle Rate	gpm	150/120
MBfR 1 pH	std units	7.2
MBfR 2 pH	std units	7.2
MBfR 1 ORP	mV	-293
MBfR 2 ORP	mV	-704
Nitrate Frequency	Hz	—
Last N Feed	ppm (N)	8.03
Last N R1	ppm (N)	1.62
Last N R2	ppm (N)	0.08
MBfR1 Sparge Rate	mm	240
MBfR2 Sparge Rate	mm	240
Phosphate Pump Settings	spm % stroke	20 30
Phosphate Concentration at Strainer	mg/LPO4	0.3
Aeration Tank Air Flow	scfm	3.2
Air Tank Pressure	psig	2
Target Media Filter Flow Rate	gpm	3
Media Filter Inlet Pressure	psig	2.9
Media Filter Outlet Pressure	psig	1.3
Sodium Hypo Pump Settings	spm % stroke	30 106
Coagulant Tank Level	gal	—
Coagulant Pump Settings	ml/min	15 ml/min
CO2 Cylinder Pressure	psi	70
H2 Cylinder Pressure	psi	91
N2 Pressure	psi	123
N2 Flow Rate	scfm	—
Turbidity (Instrument)	NTU	0.56
Turbidity (OIT)	NTU	0.57

Post Finished Water System Inspection		
Collect while sump is running		
Bag Filter ΔP	psi	4
GAC-1 Pressure	psig	7
GAC-2 Pressure	psig	4
IX-1 Pressure	psig	1

Backwash Record		
Backwash start time:		
Backwash duration	min	
Initial Product Tank Level	gal	
Final Product Tank Level	gal	
Time of sample collection:		
Location	(NTU)	TSS Collected?
Lead Purge 1		<input type="checkbox"/> Yes <input type="checkbox"/> No
Lead Purge 2		<input type="checkbox"/> Yes <input type="checkbox"/> No
Lag Purge 1		<input type="checkbox"/> Yes <input type="checkbox"/> No
Lag Purge 2		<input type="checkbox"/> Yes <input type="checkbox"/> No
Media Filter		<input type="checkbox"/> Yes <input type="checkbox"/> No

Inventory		
Type		Check
H3PO4 Stock (gal)		
Sodium Hypo Stock (gal)		
Additional Field Test Kits Needed?	Dissolved Oxygen	
	Nitrate + Nitrite	
	Nitrite	
	Sulfide	
	Chlorine	
Calibration kits needed?	o-Phosphate	
	pH	
	ORP	
	Turbidity	

Feed Tank Additions		
	H3PO4	Sodium Hypo
Time	2:45	3:00
Initial Tank Level (gal)	4	3.5
Stock Added	3.25	0
Type of Water Used For Dilution	MEDIA	NA
Volume Dilution Added (gal)	22.75	0
Total Volume Added (gal)	26.0	0
Final Tank Level (gal)	30.0	3.5

NOTES:
 CDM ONSITE. IT IS VERY WINDY, BUT CANOPY IS HOLDING UP. APT & STEERING WATER ONSITE TO TROUBLESHOOT FILTER AID. READING = 0.55 ON TURBIDIMETER. CDM CONTACT CAMERON WELDING FOR ORDER OF CO2 DEWAR &

* SAMPLE PORT IS DAMAGED, CANNOT SAMPLE

* READINGS AFTER INCIDENT DESCRIBED ON BACK

Note: There are 3785 mL per gallon.

Air Monitoring					
Zero Calibration? <input type="checkbox"/> Yes <input type="checkbox"/> No	Mixed Cylinder	Aeration Tank	MBFR 1	MBFR 2	OIT Area
Time					
Carbon Monoxide (ppm)					
Oxygen (%)					
Methane (% LEL)					
Hydrogen Sulfide (ppm)					

NOTES CONT.:

BACKUP CYLINDER. CDM INSPECTED AND REPLACED THE BAG FILTERS. A 200/¹MICRON FILTER WAS INSTALLED.

* MBFR 2 WAS DRAINED AND @ 1:30 AND OPERATED LIKE THIS FOR 15-30 MINUTES.
 APT REFILLED REACTOR @ 2:00 AND WATCHED ~~FOR~~ OPERATING NORMAL.
¹LEL

Date: 12/19/11

Time: 10:30

Operator: ARUCAN

Field Samples													
Calibration	pH calibration? <input checked="" type="checkbox"/> Yes <input type="checkbox"/> No Standards: 4 7 10 Standard Reading: 4: 4.04 7: 7.01 10: 10.12			ORP calibration? <input checked="" type="checkbox"/> Yes <input type="checkbox"/> No Temp (Deg C): 17.9 Standard Reading: 220: 213			Turbidity calibration? <input checked="" type="checkbox"/> Yes <input type="checkbox"/> No Standards: 20 200 1000 4000 Readings: 0.136: 0.166 0.30: 0.321 0.50: 0.585						
	Lead Reactor: <input type="checkbox"/> MBFR1 <input checked="" type="checkbox"/> MBFR2 Lag Sample: <input type="checkbox"/> if MBFR1 in LEAD: SP-200B <input checked="" type="checkbox"/> if MBFR2 in LEAD: SP-100B Sample Collection Time: 11:00												
Sample Data	Parameter	Units	Influent	*Lead Reactor	*Lag Reactor	Aeration	Media Filter Effluent	Post Sodium Hypo	Finished Water	GAC 1 Effluent	GAC 2 Effluent	IX 1 Effluent	Permitted Outfall
	pH	(std units)	7.15	7.50	7.57	8.00	7.82		7.84				7.51
	Temperature	(°C)	18.4	19.4	20.4	20.1	19.8		19.3				19.1
	ORP	(mV)	70	-440	-515	-230	-180		660				
	Dissolved Oxygen	(mg/L)	8	0.5	0.1	5.5	6		7				
	Nitrate + Nitrite	(mg/L-N)	8.0	1.8	0.4				0				
	Nitrite	(mg/L-N)	0	0.5	0				0				
	Sulfide	(mg/L)	0	0	1.0	0.5			0				
	Turbidity	(NTU)	0.223			1.46	0.694		0.512				
	Chlorine Residual	(mg/L)						1.5	1.2				

* Signifies MBFR 1 or MBFR 2 depending on if reactor is in the lead or lag position - this changes every 96 hours

Note: shaded boxes are to remain blank

Treatment System Inspection		
Outlet Totalizer	gal	—
Target Flow Rate	gpm	6.0
Internal Recycle Rate	gpm	150/120
MBFR 1 pH	std units	7.2
MBFR 2 pH	std units	7.2
MBFR 1 ORP	mV	-487
MBFR 2 ORP	mV	-1000
Nitrate Frequency	Hz	—
Last N Feed	ppm (N)	8.31
Last N R1	ppm (N)	0.42
Last N R2	ppm (N)	1.65
MBFR1 Sparge Rate	mm	240
MBFR2 Sparge Rate	mm	240
Phosphate Pump Settings	spm % stroke	20 30
Phosphate Concentration at Strainer	mg/LPO4	3
Aeration Tank Air Flow	scfm	3.2
Air Tank Pressure	psig	2.0
Target Media Filter Flow Rate	gpm	5.0
Media Filter Inlet Pressure	psig	7.1
Media Filter Outlet Pressure	psig	1.5
Sodium Hypo Pump Settings	spm % stroke	30 100
Coagulant Tank Level	gal	4
Coagulant Pump Settings	ml/min	7
CO2 Cylinder Pressure	psi	83
H2 Cylinder Pressure	psi	91
N2 Pressure	psi	127
N2 Flow Rate	scfm	—
Turbidity (Instrument)	NTU	0.63
Turbidity (OIT)	NTU	0.66

Post Finished Water System Inspection		
Collect while sump is running		
Bag Filter ΔP	psi	4
GAC-1 Pressure	psig	3
GAC-2 Pressure	psig	3
IX-1 Pressure	psig	1

Backwash Record		
Backwash start time:		
Backwash duration	min	
Initial Product Tank Level	gal	
Final Product Tank Level	gal	
Time of sample collection:		
Location	(NTU)	TSS Collected?
Lead Purge 1		<input type="checkbox"/> Yes <input type="checkbox"/> No
Lead Purge 2		<input type="checkbox"/> Yes <input type="checkbox"/> No
Lag Purge 1		<input type="checkbox"/> Yes <input type="checkbox"/> No
Lag Purge 2		<input type="checkbox"/> Yes <input type="checkbox"/> No
Media Filter		<input type="checkbox"/> Yes <input type="checkbox"/> No

Inventory		
Type	Check	
H3PO4 Stock (gal)	4	
Sodium Hypo Stock (gal)	30	
Additional Field Test Kits Needed?	Dissolved Oxygen	10 + 3
	Nitrate + Nitrite	6
	Nitrite	6
	Sulfide	4
	Chlorine	3
Calibration kits needed?	o-Phosphate	3 EACH
	pH	OK
	ORP	OK
	Turbidity	9 TOTAL

Feed Tank Additions		
	H3PO4	Sodium Hypo
Time	2:06	2:15
Initial Tank Level (gal)	1.0	2.7
Stock Added	200	0
Type of Water Used For Dilution	INFLUENT	N/A
Volume Dilution Added (gal)	4	0
Total Volume Added (gal)	4	0
Final Tank Level (gal)	5.0	2.7

NOTES:
 CAMERON WELDING ONSITE TO REPLACE CO2 DEMAR.
 CDM ONSITE TO TAKE WEEKLY SAMPLES & DUPLICATES.
 CDM ADJUSTED/POSTPONED SPARGE, IT WILL BE RE-SET AFTER SAMPLING IS COMPLETE.

NOTE: ORDER 4-GAS METER FROM EQUIPMENT RENTAL

Note: There are 3785 mL per gallon.

Air Monitoring					
Zero Calibration? <input type="checkbox"/> Yes <input type="checkbox"/> No	Mixed Cylinder	Aeration Tank	MBfR 1	MBfR 2	OIT Area
Time					
Carbon Monoxide (ppm)					
Oxygen (%)					
Methane (% LEL)					
Hydrogen Sulfide (ppm)					

NOTES CONT.:

• OUTLET TOTALIZER IS STUNKED UP AND HEAD HAS MOSS GROWING INSIDE IT.

Date: 10-21-11

Time: 8 AM

Operator: BEROKOFF

Field Samples														
Calibration	pH calibration? <input checked="" type="checkbox"/> Yes <input type="checkbox"/> No Standards: <input checked="" type="checkbox"/> 4 <input checked="" type="checkbox"/> 7 <input type="checkbox"/> 10 Standard Reading: 4: <u>4.01</u> 7: <u>7.07</u> 10: <u>10.21</u>			ORP calibration? <input checked="" type="checkbox"/> Yes <input type="checkbox"/> No Temp (Deg C): <u>7</u> Standard Reading: 220: <u>221</u>			Turbidity calibration? <input checked="" type="checkbox"/> Yes <input type="checkbox"/> No Standards: <input type="checkbox"/> 50 <input type="checkbox"/> 200 <input checked="" type="checkbox"/> 1000 <input checked="" type="checkbox"/> 4000 Readings: 0.136: <u>0.160</u> 0.30: <u>0.302</u> 0.50: <u>0.562</u>							
	Lead Reactor: <input checked="" type="checkbox"/> MBFR1 <input checked="" type="checkbox"/> MBFR2 SP-100A <input type="checkbox"/> if MBFR1 in LEAD: SP-200B <input type="checkbox"/> <input type="checkbox"/> if MBFR2 in LEAD: SP-100B <input checked="" type="checkbox"/>				Sample Collection Time: <u>9 AM</u>									
Sample Data	Parameter	Units	Influent	*Lead Reactor	*Lag Reactor	Aeration	Media Filter Effluent	Post Sodium Hypo	Finished Water	GAC 1 Effluent	GAC 2 Effluent	IX 1 Effluent	Permitted Outfall	
	pH	(std units)	7.61	7.66	7.71	8.12	7.97			8.01				7.79
	Temperature	(°C)	18.2	19.0	19.8	19.4	19.3			18.1				16.6
	ORP	(mV)	374	-511	-543	-188	-10			665				
	Dissolved Oxygen	(mg/L)	9	0.25	0.05	7.0	5.5			5.5				
	Nitrate + Nitrite	(mg/L-N)	8	2.0	0					0.05				
	Nitrite	(mg/L-N)	0	0.75	0					0				
	Sulfide	(mg/L)	0	0.0	0.0	0.1				0				
	Turbidity	(NTU)	0.065			1.40	0.132			0.142				
	Chlorine Residual	(mg/L)							2.5	1.5				

* Signifies MBFR 1 or MBFR 2 depending on if reactor is in the lead or lag position - this changes every 96 hours

Note: shaded boxes are to remain blank

Treatment System Inspection		
Outlet Totalizer	gal	7285800
Target Flow Rate	gpm	6
Internal Recycle Rate	gpm	120/150
MBFR 1 pH	std units	7.2
MBFR 2 pH	std units	7.2
MBFR 1 ORP	mV	-465
MBFR 2 ORP	mV	-389
Nitrate Frequency	Hz	-
Last N Feed	ppm (N)	8.29
Last N R1	ppm (N)	0.04
Last N R2	ppm (N)	1.77
MBFR1 Sparge Rate	mm	240
MBFR2 Sparge Rate	mm	240
Phosphate Pump Settings	spm	30
	% stroke	30
Phosphate Concentration at Strainer	mg/LPO4	-
Aeration Tank Air Flow	scfm	3.1
Air Tank Pressure	psig	2
Target Media Filter Flow Rate	gpm	5
Media Filter Inlet Pressure	psig	5.4
Media Filter Outlet Pressure	psig	1.6
Sodium Hypo Pump Settings	spm	30
	% stroke	100
Coagulant Tank Level	gal	2
Coagulant Pump Settings	ml/min	6
CO2 Cylinder Pressure	psi	95
H2 Cylinder Pressure	psi	90
N2 Pressure	psi	138
N2 Flow Rate	scfm	-
Turbidity (Instrument)	NTU	0.12
Turbidity (OIT)	NTU	0.39

Post Finished Water System Inspection		
Collect while sump is running		
Sump Pump dischrg	psi	
Bag Filter ΔP	psi	2
GAC-1 Pressure	psig	11
GAC-2 Pressure	psig	1
IX-1 Pressure	psig	0.3
Feed Tank Additions		
	H3PO4	Sodium Hypo
Time	10AM	10AM
Initial Tank Level (gal)	3.4	25
Stock Added	-	-
Type of Water Used For Dilution	-	-
Volume Dilution Added (gal)	-	-
Total Volume Added (gal)	-	-
Final Tank Level (gal)	3.4	25

Note: There are 3785 ml. per gallon.

Backwash Record		
Backwash start time:		
Backwash duration	min	
Initial Product Tank Level	gal	
Final Product Tank Level	gal	
Time of sample collection:		
Location (NTU)		TSS Collected?
Lead Purge 1		<input type="checkbox"/> Yes <input type="checkbox"/> No
Lead Purge 2		<input type="checkbox"/> Yes <input type="checkbox"/> No
Lag Purge 1		<input type="checkbox"/> Yes <input type="checkbox"/> No
Lag Purge 2		<input type="checkbox"/> Yes <input type="checkbox"/> No
Media Filter		<input type="checkbox"/> Yes <input type="checkbox"/> No

NOTES:
 HYDROGEN SULFIDE ODR WAS NOT STRONG TODAY, EVEN WHEN REMOVING THE AERATION LID THE SMELL DISSIPATED QUICKLY. LAG/AERATION SULFIDE LEVELS WERE LOWER THAN MONDAY'S OUTING. APT CAME ON SITE TO TOP OFF FILTER AID.

Inventory		
Type	Check	
H3PO4 Stock (gal)	4	
Sodium Hypo Stock (gal)	30	
Additional Field Test Kits Needed?	Dissolved Oxygen	10/3
	Nitrate + Nitrite	5
	Nitrite	6
	Sulfide	2
	Chlorine	5
Calibration Kits needed?	o-Phosphate	3
	pH	✓
	ORP	✓
	Turbidity	✓

Date: 12/23/11

Time: 9:30 AM

Operator: BEROKOFF

Treatment System Inspection

Field Samples												
Calibration	pH calibration? <input checked="" type="checkbox"/> Yes <input type="checkbox"/> No	ORP calibration? <input checked="" type="checkbox"/> Yes <input type="checkbox"/> No		Turbidity calibration? <input checked="" type="checkbox"/> Yes <input type="checkbox"/> No								
	Standards: <input checked="" type="checkbox"/> 4 <input checked="" type="checkbox"/> 7 <input checked="" type="checkbox"/> 20	Temp (Deg C): <u>10.5</u>		Standards: <input type="checkbox"/> 20 <input type="checkbox"/> 200 <input type="checkbox"/> 1000 <input type="checkbox"/> 4000								
Standard Reading: 4: <u>4.01</u> 7: <u>7.06</u> 10: <u>10.18</u>			Standard Reading: 220: <u>221</u>			Readings: 0.136: _____ 0.30: _____ 0.50: _____						
Lead Reactor: <input checked="" type="checkbox"/> MBR1 <input type="checkbox"/> MBR2 Lag Reactor: <input checked="" type="checkbox"/> MBR1 in LEAD: SP-200B <input type="checkbox"/> MBR2 in LEAD: SP-100B Sample Collection Time: <u>10:30 AM</u>												
Parameter	Units	Influent	*Lead Reactor	*Lag Reactor	Aeration	Media Filter Effluent	Post Sodium Hypo	Finished Water	GAC 1 Effluent	GAC 2 Effluent	IX 1 Effluent	Permitted Outfall
pH	(std units)	7.64	7.77	7.54	8.02	7.88		7.97				7.83
Temperature	(°C)	18.6	19.1	19.9	19.6	19.5		18.3				17.5
ORP	(mV)	184	-501	-514	-205	-49		630				
Dissolved Oxygen	(mg/L)	9.0	0.35	0.10	7.0	4.5		5.5				
Nitrate + Nitrite	(mg/L-N)	9.0	2.0	0				0.1				
Nitrite	(mg/L-N)	0	0.8	0				0				
Sulfide	(mg/L)	0	0	0.6	0.25			0				
Turbidity	(NTU)	0.069			1.6	0.111		0.124				
Chlorine Residual	(mg/L)						2.5	1.5				

Outlet Totalizer	gal	7304000
Target Flow Rate	gpm	6
Internal Recycle Rate	gpm	150/120
MBfR 1 pH	std units	7.2
MBfR 2 pH	std units	7.2
MBfR 1 ORP	mV	-267
MBfR 2 ORP	mV	-621
Nitrate Frequency	Hz	-
Last N Feed	ppm (N)	8.32
Last N R1	ppm (N)	1.58
Last N R2	ppm (N)	0.13
MBfR1 Sparge Rate	mm	240
MBfR2 Sparge Rate	mm	240
Phosphate Pump Settings	spm	30
Phosphate Concentration at Strainer	% stroke	30
Phosphate Concentration at Strainer	mg/LPO4	0.15
Aeration Tank Air Flow	scfm	3.2
Air Tank Pressure	psig	2.0
Target Media Filter Flow Rate	gpm	5
Media Filter Inlet Pressure	psig	0
Media Filter Outlet Pressure	psig	0.4
Sodium Hypo Pump Settings	spm	30
Sodium Hypo Pump Settings	% stroke	100
Coagulant Tank Level	gal	20
Coagulant Pump Settings	ml/min	6
CO2 Cylinder Pressure	psi	89
H2 Cylinder Pressure	psi	89
N2 Pressure	psi	143
N2 Flow Rate	scfm	-
Turbidity (Instrument)	NTU	0.08
Turbidity (OIT)	NTU	0.43

Post Finished Water System Inspection		
Collect while sump is running		
Sump Pump dischrg	psi	
Bag Filter ΔP	psi	2
GAC-1 Pressure	psig	13
GAC-2 Pressure	psig	1
IX-1 Pressure	psig	0.5
Feed Tank Additions		
	H3PO4	Sodium Hypo
Time	10AM	10AM
Initial Tank Level (gal)	2.7	18
Stock Added	300	0
Type of Water Used For Dilution	INF	MED FILT.
Volume Dilution Added (gal)	2.3	12
Total Volume Added (gal)	2.3	12
Final Tank Level (gal)	5	30

Note: There are 3785 mL per gallon.

Backwash Record		
Backwash start time:		
Backwash duration	min	
Initial Product Tank Level	gal	
Final Product Tank Level	gal	
Time of sample collection:		
Location	(NTU)	TSS Collected?
Lead Purge 1		<input type="checkbox"/> Yes <input type="checkbox"/> No
Lead Purge 2		<input type="checkbox"/> Yes <input type="checkbox"/> No
Lag Purge 1		<input type="checkbox"/> Yes <input type="checkbox"/> No
Lag Purge 2		<input type="checkbox"/> Yes <input type="checkbox"/> No
Media Filter		<input type="checkbox"/> Yes <input type="checkbox"/> No

NOTES: SITE
 MEDIA FILTER TRIGGERED A BACKWASH JUST PRIOR TO ARRIVAL.
 CDM UNABLE TO COLLECT BACKWASH SAMPLE FOR MEDIA FILTER.
 APT ON SITE TO TOP OFF COAGULANT TANK. APT LOWERED COAGULANT FLOW RATE TO 4 mL/MIN (FROM 6). CHLORINE RESIDUAL ON PRODUCT WATER WAS HIGH, TOPPED OFF TANK WITH MEDIA FILTER TO DILUTE CL2 CONCENTRATION.

Inventory		
Type	Check	
H3PO4 Stock (gal)	/	
Sodium Hypo Stock (gal)	/	
Additional Field Test Kits Needed?	Dissolved Oxygen	/
	Nitrate + Nitrite	/
	Nitrite	/
	Sulfide	/
	Chlorine	/
Calibration kits needed?	pH	/
	ORP	/
	Turbidity	/

Date: 12/27/11

Time: 8:45 AM

Operator: BEROKOFF

Field Samples												
Calibration	pH calibration? <input checked="" type="checkbox"/> Yes <input type="checkbox"/> No			ORP calibration? <input checked="" type="checkbox"/> Yes <input type="checkbox"/> No			Turbidity calibration? <input checked="" type="checkbox"/> Yes <input type="checkbox"/> No					
	Standards: <input checked="" type="checkbox"/> 4 <input checked="" type="checkbox"/> 7 <input checked="" type="checkbox"/> 10			Temp (Deg C): <u>9.4</u>			Standards: <input checked="" type="checkbox"/> 0 <input type="checkbox"/> 20 <input checked="" type="checkbox"/> 200 <input checked="" type="checkbox"/> 1000 <input checked="" type="checkbox"/> 4000					
Standard Reading: 4: <u>4.01</u> 7: <u>7.07</u> 10: <u>10.18</u>			Standard Reading: 220: <u>221</u>			Readings: 0.136: 0.30: 0.50:						
Lead Sample <input type="checkbox"/> Lag Sample <input type="checkbox"/> Lead Reactor: <input type="checkbox"/> MBR1 <input checked="" type="checkbox"/> MBR2 SP-100A <input type="checkbox"/> if MBR1 in LEAD: SP-200B <input type="checkbox"/> if MBR2 in LEAD: SP-100B <input checked="" type="checkbox"/>												
Sample Collection Time: <u>9:30 AM</u>												
Parameter	Units	Influent	*Lead Reactor	*Lag Reactor	Aeration	Media Filter Effluent	Post Sodium Hypo	Finished Water	GAC 1 Effluent	GAC 2 Effluent	IX 1 Effluent	Permitted Outfall
pH	(std units)	7.58	7.63	7.68	8.09	7.90		7.96				7.75
Temperature	(°C)	18.4	19.4	20.4	20.0	20.0		18.9				18.5
ORP	(mV)	402	-521	-533	-182	-17		630				
Dissolved Oxygen	(mg/L)	9.0	0.25	0.10	5.5	3.5		7.0				
Nitrate + Nitrite	(mg/L-N)	9.0	2.25	0				0.4				
Nitrite	(mg/L-N)	0	0.85	0				0				
Sulfide	(mg/L)	0	0	0.6	0.2			0				
Turbidity	(NTU)	0.087			1.30	0.175		0.175				
Chlorine Residual	(mg/L)							2.0	1.1			

* Signifies MBR 1 or MBR 2 depending on if reactor is in the lead or lag position - this changes every 96 hours

Note: shaded boxes are to remain blank

Treatment System Inspection		
Outlet Totalizer	gal	7339400
Target Flow Rate	gpm	6
Internal Recycle Rate	gpm	154120
MBFR 1 pH	std units	7.2
MBFR 2 pH	std units	7.2
MBFR 1 ORP	mV	-446
MBFR 2 ORP	mV	-865
Nitrate Frequency	Hz	-
Last N Feed	ppm (N)	8.32
Last N R1	ppm (N)	0.06
Last N R2	ppm (N)	1.68
MBFR1 Sparge Rate	mm	240
MBFR2 Sparge Rate	mm	240
Phosphate Pump Settings	spm	30
	% stroke	30
Phosphate Concentration at Strainer	mg/LPO4	1.5
Aeration Tank Air Flow	scfm	3.2
Air Tank Pressure	psig	2.0
Target Media Filter Flow Rate	gpm	5
Media Filter Inlet Pressure	psig	2.9
Media Filter Outlet Pressure	psig	1.6
Sodium Hypo Pump Settings	spm	30
	% stroke	100
Coagulant Tank Level	gal	15
Coagulant Pump Settings	ml/min	3
CO2 Cylinder Pressure	psi	110
H2 Cylinder Pressure	psi	88
N2 Pressure	psi	148
N2 Flow Rate	scfm	-
Turbidity (Instrument)	NTU	0.14
Turbidity (OIT)	NTU	0.47

Post Finished Water System Inspection		
Collect while sump is running		
Sump Pump dischrg	psi	
Bag Filter ΔP	psi	2
GAC INFLUENT	psig	12
GAC EFFLUENT	psig	1
IX-1 Pressure	psig	0.8
Feed Tank Additions		
	H3PO4	Sodium Hypo
Time	12:30	9:30
Initial Tank Level (gal)	1.8	23
Stock Added	100ml	-
Type of Water Used For Dilution	INF	-
Volume Dilution Added (gal)	3.2	-
Total Volume Added (gal)	3.2	-
Final Tank Level (gal)	5	23

Note: There are 3785 mL per gallon.

Backwash Record		
Backwash start time:		
Backwash duration	min	
Initial Product Tank Level	gal	
Final Product Tank Level	gal	
Time of sample collection:		
Location (NTU)	TSS Collected?	
Lead Purge 1	<input type="checkbox"/> Yes	<input type="checkbox"/> No
Lead Purge 2	<input type="checkbox"/> Yes	<input type="checkbox"/> No
Lag Purge 1	<input type="checkbox"/> Yes	<input type="checkbox"/> No
Lag Purge 2	<input type="checkbox"/> Yes	<input type="checkbox"/> No
Media Filter	<input type="checkbox"/> Yes	<input type="checkbox"/> No

NOTES:
 APT LOWERED COAGULANT PUMP TO DOSE AT 3 M/MIN (FROM 4)
 SUMP PUMP IS WHINNING VERY LOUDLY. MEASURED AIR QUALITY W/ 4-GAS METER. TOOK MEASUREMENTS WITH AERATION COVER BOTH OPEN AND CLOSED. HAS READ ZERO

Inventory		
	Type	Check
Additional Field Test Kits Needed?	H3PO4 Stock (gal)	/
	Sodium Hypo Stock (gal)	/
	Dissolved Oxyge	/
	Nitrate + Nitrite	/
	Nitrite	/
	Sulfide	/
	o-Phosphate	/
Calibration kits needed?	pH	/
	ORP	/
	Turbidity	/

Air Monitoring					
Zero Calibration? <input checked="" type="checkbox"/> Yes <input type="checkbox"/> No	Mixed Cylinder	Aeration Tank	AERATION TANK METER OPEN LID	MBFR 2	OIT Area
Time	11:45	12:15	12:20		12:50
Carbon Monoxide (ppm)	48	3	8		0
Oxygen (%)		21.9	21.9		21.7
Methane (% LEL)	49	0	0		0
Hydrogen Sulfide (ppm)	25	0	0		0

NOTES CONT:

MONITORING
 AT ALL LOCATIONS ~~WHERE IT~~ LEFT METER RUNNING CONTINUOUSLY FOR APPROXIMATELY 1.5 HOURS.

Date: 12/28/11

Time: 9AM

Operator: BERKOFF

Field Samples													
Calibration	pH calibration? <input checked="" type="checkbox"/> Yes <input type="checkbox"/> No			ORP calibration? <input type="checkbox"/> Yes <input type="checkbox"/> No			Turbidity calibration? <input checked="" type="checkbox"/> Yes <input type="checkbox"/> No						
	Standards: <input checked="" type="checkbox"/> 4 <input checked="" type="checkbox"/> 7 <input checked="" type="checkbox"/> 10			Temp (Deg C): <u>15.1</u>			Standards: <input type="checkbox"/> 0 <input type="checkbox"/> 20 <input type="checkbox"/> 200 <input type="checkbox"/> 1000 <input type="checkbox"/> 4000			Readings:			
Standard Reading: 4: <u>4.00</u> 7: <u>7.03</u> 10: <u>10.12</u>			Standard Reading: 220: <u>2.21</u>			0.136: <u>0.186</u> 0.30: <u>0.332</u> 0.50: <u>0.562</u>							
Lead Sample <input type="checkbox"/> Lag Sample <input type="checkbox"/> Lead Reactor: <input type="checkbox"/> MBR1 <input type="checkbox"/> MBR2 <input type="checkbox"/> SP-100A <input type="checkbox"/> If MBR1 in LEAD: SP-200B <input type="checkbox"/> If MBR2 in LEAD: SP-100B <input checked="" type="checkbox"/>													
										Sample Collection Time: <u>9:40</u>			
Sample Data	Parameter	Units	Influent	*Lead Reactor	*Lag Reactor	Aeration	Media Filter Effluent	Post Sodium Hypo	Finished Water	GAC 1 Effluent	GAC 2 Effluent	IX 1 Effluent	Permitted Outfall
	pH	(std units)	7.55	7.47	7.58	8.04	7.80		7.89				7.70
	Temperature	(°C)	18.9	20.2	21.3	21.0	21.0		20.6				20.6
	ORP	(mV)	188	-493	-491	-200	-20		596				
	Dissolved Oxygen	(mg/L)	9.0	0.20	0.1	7.0	5.5		7.0				
	Nitrate + Nitrite	(mg/L-N)	9.0	2.1	0				0.5				
	Nitrite	(mg/L-N)	0	0.85	0				0				
	Sulfide	(mg/L)	0	0	0.6	0.2			0				
	Turbidity	(NTU)	0.069					0.116					
	Chlorine Residual	(mg/L)							1.6	1.0			

* Signifies MBR 1 or MBR 2 depending on if reactor is in the lead or lag position - this changes every 96 hours

Note: shaded boxes are to remain blank

Treatment System Inspection		
Outlet Totalizer	gal	7348300
Target Flow Rate	gpm	6
Internal Recycle Rate	gpm	150/120
MBFR 1 pH	std units	7.2
MBFR 2 pH	std units	7.2
MBFR 1 ORP	mV	-442
MBFR 2 ORP	mV	-951
Nitrate Frequency	Hz	-
Last N Feed	ppm (N)	8.33
Last N R1	ppm (N)	0.1
Last N R2	ppm (N)	1.53
MBFR1 Sparge Rate	mm	240
MBFR2 Sparge Rate	mm	240
Phosphate Pump Settings	spm	20
Phosphate Concentration at Strainer	mg/LPO4	1.4 1.5
Aeration Tank Air Flow	scfm	3.1
Air Tank Pressure	psig	2.0
Target Media Filter Flow Rate	gpm	5
Media Filter Inlet Pressure	psig	1.1
Media Filter Outlet Pressure	psig	1.6
Sodium Hypo Pump Settings	spm	30
Coagulant Tank Level	gal	14
Coagulant Pump Settings	ml/min	3
CO2 Cylinder Pressure	psi	110
H2 Cylinder Pressure	psi	90
N2 Pressure	psi	143
N2 Flow Rate	scfm	-
Turbidity (Instrument)	NTU	0.59 0.46
Turbidity (OIT)	NTU	0.46

Post Finished Water System Inspection		
Collect while sump is running		
Sump Pump dischr	psi	
Bag Filter ΔP	psi	15 2
GAC-1 Pressure	psig	13
GAC-2 Pressure	psig	0
IX-1 Pressure	psig	0.8
Feed Tank Additions		
	H3PO4	Sodium Hypo
Time	9:00AM	10AM
Initial Tank Level (gal)	4.3	21
Stock Added	-	0
Type of Water Used For Dilution	-	MED. FILT.
Volume Dilution Added (gal)	-	9gal
Total Volume Added (gal)	-	9gal
Final Tank Level (gal)	4.3	30

Note: There are 3785 mL per gallon.

Backwash Record		
Backwash start time:		
Backwash duration	min	
Initial Product Tank Level	gal	
Final Product Tank Level	gal	
Time of sample collection:		
Location	(NTU)	TSS Collected?
Lead Purge 1		<input type="checkbox"/> Yes <input type="checkbox"/> No
Lead Purge 2		<input type="checkbox"/> Yes <input type="checkbox"/> No
Lag Purge 1		<input type="checkbox"/> Yes <input type="checkbox"/> No
Lag Purge 2		<input type="checkbox"/> Yes <input type="checkbox"/> No
Media Filter		<input type="checkbox"/> Yes <input type="checkbox"/> No

NOTES:

INLINE TURBIDIMETER (OR INSTRUMENT) IS READING ~2.2.
 THERE IS ALSO A NEGATIVE DP ON FILTER INLET/OUTLET.
 MCDM NOTIFIED APT - RICH BUDAY CAME TO SITE TO WORK ON THIS. TOPPED OFF CL2 TANK DUE TO RESIDUAL HIGH

Inventory		
Type	Check	
H3PO4 Stock (gal)	3.5	
Sodium Hypo Stock (gal)	30+	
Additional Field Test Kits Needed?	Dissolved Oxygen	5+3
	Nitrate + Nitrite	5
	Nitrite	5
	Sulfide	2
	Chlorine	4
Calibration kits needed?	o-Phosphate	3
	pH	✓
	ORP	✓
	Turbidity	✓

Air Monitoring					
Zero Calibration <input checked="" type="checkbox"/> Yes <input checked="" type="checkbox"/> No	Mixed Cylinder	Aeration Tank LID CLOSED	AERATION TANK LID OPEN	MBIR 2	OIT Area
Time		9:30	9:45		
Carbon Monoxide (ppm)		0	10		
Oxygen (%)		20.9	20.9		
Methane (% LEL)		0	0		
Hydrogen Sulfide (ppm)		0	0		

NOTES CONT:

ON FINISHED EFFLUENT, APT WAS ABLE TO FIX HIGH TURBIDITY ISSUE (THERE WAS NO FLOW GOING INTO THE METER). TURBIDITY ~~WAS~~ STABILIZED AT 0.09 NTU.

Date: 12/30/11

Time: 9:00

Operator: ARUCAN

Treatment System Inspection

Field Samples													
Calibration	pH calibration? <input checked="" type="checkbox"/> Yes <input type="checkbox"/> No Standards: <input type="checkbox"/> 4 <input type="checkbox"/> 7 <input type="checkbox"/> 10 Standard Reading: 4: <u>4.07</u> 7: <u>7.05</u> 10: <u>10.11</u>			ORP calibration? <input checked="" type="checkbox"/> Yes <input type="checkbox"/> No Temp (Deg C): <u>14.5</u> Standard Reading: 220: <u>217</u>			Turbidity calibration? <input checked="" type="checkbox"/> Yes <input type="checkbox"/> No Standards: <input type="checkbox"/> 10 <input type="checkbox"/> 20 <input type="checkbox"/> 200 <input type="checkbox"/> 1000 <input type="checkbox"/> 4000 Readings: 0.136: <u>0.151</u> 0.30: <u>0.321</u> 0.50: <u>0.463</u>						
	Lead Reactor: <input checked="" type="checkbox"/> MBfR1 <input type="checkbox"/> MBfR2 SP-100A <input checked="" type="checkbox"/> if MBfR1 in LEAD: SP-200B <input checked="" type="checkbox"/> <input type="checkbox"/> if MBfR2 in LEAD: SP-100B <input type="checkbox"/>			Lag Sample			Sample Collection Time: <u>11:00</u>						
Sample Data	Parameter	Units	Influent	*Lead Reactor	*Lag Reactor	Aeration	Media Filter Effluent	Post Sodium Hypo	Finished Water	GAC 1 Effluent	GAC 2 Effluent	IX 1 Effluent	Permitted Outfall
	pH	(std units)	<u>7.39</u>	<u>7.55</u>	<u>7.46</u>	<u>7.92</u>	<u>7.67</u>		<u>7.44</u>				<u>7.38</u>
	Temperature	(°C)	<u>18.1</u>	<u>20.3</u>	<u>21.3</u>	<u>21.0</u>	<u>21.1</u>		<u>20.9</u>				<u>20.7</u>
	ORP	(mV)	<u>80</u>	<u>-490</u>	<u>-540</u>	<u>-235</u>	<u>-180</u>		<u>120</u>				
	Dissolved Oxygen	(mg/L)	<u>8</u>	<u>0.3</u>	<u>0.05</u>	<u>6</u>	<u>6</u>		<u>7</u>				
	Nitrate + Nitrite	(mg/L-N)	<u>8.75</u>	<u>1.8</u>	<u>0.4</u>				<u>0.4</u>				
	Nitrite	(mg/L-N)	<u>0</u>	<u>0.6</u>	<u>0</u>				<u>0</u>				
	Sulfide	(mg/L)	<u>0</u>	<u>0</u>	<u>2.0</u>	<u>1.5</u>			<u>0</u>				
	Turbidity	(NTU)	<u>0.264</u>			<u>1.89</u>	<u>0.207</u>		<u>0.216</u>				
	Chlorine Residual	(mg/L)						<u>0</u>	<u>0</u>				

* Signifies MBfR 1 or MBfR 2 depending on if reactor is in the lead or lag position - this changes every 96 hours

Note: shaded boxes are to remain blank

Post Finished Water System Inspection		
Collect while sump is running		
Sump Pump dischrg	psi	<u>17</u>
Bag Filter ΔP	psi	<u>5</u>
GAC INFLUENT	psig	<u>10</u>
GAC EFFLUENT	psig	
IX-1 Pressure	psig	<u>1</u>
Feed Tank Additions		
	H3PO4	Sodium Hypo
Time	<u>1:00</u>	<u>1:15</u>
Initial Tank Level (gal)	<u>15</u>	<u>20</u>
Stock Added	<u>250</u>	<u>0</u>
Type of Water Used For Dilution	<u>INF</u>	<u>N/A</u>
Volume Dilution Added (gal)	<u>3.5</u>	<u>N/A</u>
Total Volume Added (gal)	<u>3.5</u>	<u>N/A</u>
Final Tank Level (gal)	<u>8</u>	<u>20</u>

Note: There are 3785 mL per gallon.

Backwash Record		
Backwash start time:		
Backwash duration	min	
Initial Product Tank Level	gal	
Final Product Tank Level	gal	
Time of sample collection:		
Location	(NTU)	TSS Collected?
Lead Purge 1	<u>12.6</u>	<input checked="" type="checkbox"/> Yes <input type="checkbox"/> No
Lead Purge 2	<u>10.1</u>	<input type="checkbox"/> Yes <input type="checkbox"/> No
Lag Purge 1	<u>18.9</u>	<input checked="" type="checkbox"/> Yes <input type="checkbox"/> No
Lag Purge 2	<u>9.4</u>	<input checked="" type="checkbox"/> Yes <input type="checkbox"/> No
Media Filter		<input checked="" type="checkbox"/> Yes <input type="checkbox"/> No

NOTES:

CDM REDUCED CO₂ FEED PRESSURE FROM 106 TO 89 PSI. CDM WILL ALSO BE CONDUCTING AIR SAMPLING. RESULTS ON BACK. CDM INCREASED HYPO PUMP RATE TO 40 SPM @ 100% DUE TO LOW CHLORINE RESIDUAL

Outlet Totalizer	gal	<u>73669</u>
Target Flow Rate	gpm	<u>6</u>
Internal Recycle Rate	gpm	<u>150/12</u>
MBfR 1 pH	std units	<u>7.2</u>
MBfR 2 pH	std units	<u>7.4</u>
MBfR 1 ORP	mV	<u>-245</u>
MBfR 2 ORP	mV	<u>-641</u>
Nitrate Frequency	Hz	
Last N Feed	ppm (N)	<u>8.35</u>
Last N R1	ppm (N)	<u>1.38</u>
Last N R2	ppm (N)	<u>0.62</u>
MBfR1 Sparge Rate	mm	<u>240</u>
MBfR2 Sparge Rate	mm	<u>240</u>
Phosphate Pump Settings	sprn	<u>20</u>
	% stroke	<u>30</u>
Phosphate Concentration at Strainer	mg/LPO4	<u>12.3</u>
Aeration Tank Air Flow	scfm	<u>3.2</u>
Air Tank Pressure	psig	<u>2.0</u>
Target Media Filter Flow Rate	gpm	<u>5.0</u>
Media Filter Inlet Pressure	psig	<u>5.2</u>
Media Filter Outlet Pressure	psig	<u>2.3</u>
Sodium Hypo Pump Settings	sprn	<u>30</u>
	% stroke	<u>100</u>
Coagulant Tank Level	gal	<u>11</u>
Coagulant Pump Settings	ml/min	<u>4</u>
CO2 Cylinder Pressure	psi	<u>106</u>
H2 Cylinder Pressure	psi	<u>71</u>
N2 Pressure	psi	<u>146</u>
N2 Flow Rate	scfm	
Turbidity (Instrument)	NTU	<u>0.17</u>
Turbidity (OIT)	NTU	<u>0.15</u>

ESTCP: Technology Demonstration Plan
 Perchlorate Destruction Using Membrane Biofilm Reduction
 ESTCP Project Number ER-200541

Air Monitoring							
Zero Calibration? <input type="checkbox"/> Yes <input type="checkbox"/> No	Mixed Cylinder	Aeration Tank	MBFR 1	MBFR 2	OIT Area	FRESH AIR	MIX CYLINDER CONC.
	9:15	9:23	9:30	9:30	9:35	9:10	—
Carbon Monoxide (ppm)	47	31	5	12	0	0	50
Oxygen (%)	11.8	20.9	20.2	20.3	20.9	20.9	12
Methane (% LEL)	49%	0	0	0	0	0	50
Hydrogen Sulfide (ppm)	23	2	0	0	0	0	25

NOTES CONT.:

CDM DID BAG FILTER CHANGE - OUT, CDM DETERMINED THAT GPC-2 PRESSURE GAUGE IS NOT FUNCTIONAL. A NEW ONE NEEDS TO BE ORDERED, IX PRESSURE LOOKS TO BE NORMAL. SPARGE WAS MANUALLY INITIATED @ 12:10. PHOSPHATE^{CONC.} AFTER ADDITION = 14 ppm.

Date: 1/3/12

Time: 10:00

Operator: ARUCAN

Treatment System Inspection

Outlet Totalizer	gal	74052
Target Flow Rate	gpm	6
Internal Recycle Rate	gpm	120/15
MBfR 1 pH	std units	7.2
MBfR 2 pH	std units	7.2
MBfR 1 ORP	mV	-452
MBfR 2 ORP	mV	-901
Nitrate Frequency	Hz	—
Last N Feed	ppm (N)	0.38
Last N R1	ppm (N)	0.35
Last N R2	ppm (N)	1.50
MBfR1 Sparge Rate	mm	240
MBfR2 Sparge Rate	mm	240
Phosphate Pump Settings	spm % stroke	30 30
Phosphate Concentration at Strainer	mg/LPO4	1.3
Aeration Tank Air Flow	scfm	3.2
Air Tank Pressure	psig	2.0
Target Media Filter Flow Rate	gpm	5.0
Media Filter Inlet Pressure	psig	2.1
Media Filter Outlet Pressure	psig	2.3
Sodium Hypo Pump Settings	spm % stroke	40 100
Coagulant Tank Level	gal	5
Coagulant Pump Settings	ml/min	5
CO2 Cylinder Pressure	psi	93
H2 Cylinder Pressure	psi	91
N2 Pressure	psi	142
N2 Flow Rate	scfm	—
Turbidity (Instrument)	NTU	.21
Turbidity (OIT)	NTU	.22

Field Samples

Calibration	pH calibration? <input checked="" type="checkbox"/> Yes <input type="checkbox"/> No Standards: <input type="checkbox"/> 4 <input type="checkbox"/> 7 <input type="checkbox"/> 10 Standard Reading: 4: <u>4.11</u> 7: <u>7.07</u> 10: <u>10.09</u>		ORP calibration? <input checked="" type="checkbox"/> Yes <input type="checkbox"/> No Temp (Deg C): <u>18.2</u> Standard Reading: 220: <u>224</u>		Turbidity calibration? <input checked="" type="checkbox"/> Yes <input type="checkbox"/> No Standards: 20 220 2200 1000 4000 Readings: 0.136: <u>0.143</u> 0.30: <u>0.319</u> 0.50: <u>0.489</u>								
	Lead Reactor: <input type="checkbox"/> MfBR1 <input checked="" type="checkbox"/> MfBR2 SP-100A <input checked="" type="checkbox"/> if MfBR1 in LEAD: SP-200B <input type="checkbox"/> if MfBR2 in LEAD: SP-100B <input checked="" type="checkbox"/>		Sample Collection Time: <u>12:00</u>										
Sample Data	Parameter	Units	Influent	*Lead Reactor	*Lag Reactor	Aeration	Media Filter Effluent	Post Sodium Hypo	Finished Water	GAC 1 Effluent	GAC 2 Effluent	IX 1 Effluent	Permitted Outfall
	pH	(std units)	7.49	7.03	7.54	7.99	7.71		7.39				7.44
	Temperature	(°C)	18.3	21.1	21.9	21.4	21.3		20.9				20.9
	ORP	(mV)	90	-440	-570	-210	-145		60				
	Dissolved Oxygen	(mg/L)	8.5	0.1	0	7	7.5		8				
	Nitrate + Nitrite	(mg/L-N)	8.7	2.1	0.4				0.6				
	Nitrite	(mg/L-N)	0	0.75	0				0				
	Sulfide	(mg/L)	0	0	1.4	1.1			0				
	Turbidity	(NTU)	0.192			1.69	0.207		0.248				
	Chlorine Residual	(mg/L)							0*	0*			

* Signifies MBfR 1 or MBfR 2 depending on if reactor is in the lead or lag position - this changes every 96 hours

Note: shaded boxes are to remain blank

Post Finished Water System Inspection		
Collect while sump is running		
Sump Pump dischrg	psi	16
Bag Filter ΔP	psi	4
GAC-1 Pressure	psig	11
GAC-2 Pressure	psig	5
IX-1 Pressure	psig	1.3
Feed Tank Additions		
	H3PO4	Sodium Hypo
Time	1:45	2:15
Initial Tank Level (gal)	1.25	10
Stock Added	325	2.0
Type of Water Used For Dilution	3.75	MF
Volume Dilution Added (gal)	MF	18.0
Total Volume Added (gal)	3.75	10 20
Final Tank Level (gal)	5	10 30

SAC IN
SAC OUT
2:15
10
2.0
MF
18.0

Note: There are 3785 ml. per gallon.

Backwash Record		
Backwash start time:		
Backwash duration	min	
Initial Product Tank Level	gal	
Final Product Tank Level	gal	
Time of sample collection:		
Location (NTU)		TSS Collected?
Lead Purge 1		<input type="checkbox"/> Yes <input type="checkbox"/> No
Lead Purge 2		<input type="checkbox"/> Yes <input type="checkbox"/> No
Lag Purge 1		<input type="checkbox"/> Yes <input type="checkbox"/> No
Lag Purge 2		<input type="checkbox"/> Yes <input type="checkbox"/> No
Media Filter		<input type="checkbox"/> Yes <input type="checkbox"/> No

NOTES:
 CDM CHANGED GAC-2 PRESSURE GAUGE. CDM CONDUCTED AIR MONITORING. RESULTS ARE ON NEXT PAGE.

* CHLORINE ADDITION: POST = 1.5
 (25 MINS. AFTER) TANK = 0.1
 B-127

Inventory		
Type	Check	
H3PO4 Stock (gal)	3	
Sodium Hypo Stock (gal)	30	
Additional Field Test Kits Needed?	Dissolved Oxygen	10 + 3
	Nitrate + Nitrite	5
	Nitrite	5
	Sulfide	2
	Chlorine	4
Calibration kits needed?	α-Phosphate	3
	pH	1
	ORP	1
Turbidity	1	

ESTCP: Technology Demonstration Plan
 Perchlorate Destruction Using Membrane Biofilm Reduction
 ESTCP Project Number ER-200541

Air Monitoring					
Zero Calibration? <input checked="" type="checkbox"/> Yes <input type="checkbox"/> No	Mixed Cylinder	Aeration Tank	MBFR 1	MBFR 2	OFT Area
Time	9:55	10:20	10:10	10:11	10:15
Carbon Monoxide (ppm)	43	24	200	75	0
Oxygen (%)	21	20.9	20.9	20.8	20.9
Methane (% LEL)	33	0	0	0	0
Hydrogen Sulfide (ppm)	20	1	0	0	0

FRESH AIR

10:05
 0
 20.7
 0
 0

NOTES CONT.:

Date: 1/4/12

Time: 9:30

Operator: BEROKOFF

Calibration		Field Samples												
pH calibration? <input checked="" type="checkbox"/> Yes <input type="checkbox"/> No Standards: <input checked="" type="checkbox"/> 4 <input checked="" type="checkbox"/> 7 <input checked="" type="checkbox"/> 10 Standard Reading: 4: <u>4.01</u> 7: <u>7.02</u> 10: <u>10.06</u>		ORP calibration? <input type="checkbox"/> Yes <input type="checkbox"/> No Temp (Deg C): <u>20.5</u> Standard Reading: 220: <u>219</u>				Turbidity calibration? <input checked="" type="checkbox"/> Yes <input type="checkbox"/> No Standards: <input type="checkbox"/> 0 <input type="checkbox"/> 20 <input type="checkbox"/> 200 <input checked="" type="checkbox"/> 1000 <input checked="" type="checkbox"/> 4000 Readings: 0.136: <u>0.157</u> 0.30: <u>0.347</u> 0.50: <u>0.561</u>								
Lead Sample		Lag Sample		Sample Collection Time: <u>10:15</u>										
Lead Reactor: <input type="checkbox"/> MfBR1 <input checked="" type="checkbox"/> MfBR2		SP-100A <input type="checkbox"/>		if MBfR1 in LEAD: SP-200B <input type="checkbox"/>		if MBfR2 in LEAD: SP-100B <input checked="" type="checkbox"/>								
Parameter	Units	Influent	*Lead Reactor	*Lag Reactor	Aeration	Media Filter Effluent	Post Sodium Hypo	Finished Water	GAC 1 Effluent	GAC 2 Effluent	IX 1 Effluent	Permitted Outfall		
pH	(std units)	7.54	7.33	7.48	7.97	7.73		7.76				7.42		
Temperature	(°C)	19.6	20.9	21.9	21.6	21.8		22.0				22.7		
ORP	(mV)	368	-487	-484	-211	-132		690						
Dissolved Oxygen	(mg/L)	9.0	0.15	0.10	7.0	3.5		4.5						
Nitrate + Nitrite	(mg/L-N)	9.0	1.6	0				0.7						
Nitrite	(mg/L-N)	0	0.85	0				0						
Sulfide	(mg/L)	0	0	2.5	1.0	0.1		0						
Turbidity	(NTU)	0.105			1.86	0.295		0.410						
Chlorine Residual	(mg/L)							2.5	2.0					

* Signifies MBfR 1 or MBfR 2 depending on if reactor is in the lead or lag position - this changes every 96 hours

Note: shaded boxes are to remain blank

Treatment System Inspection		
Outlet Totalizer	gal	7409800
Target Flow Rate	gpm	6
Internal Recycle Rate	gpm	59/100
MBfR 1 pH	std units	7.2
MBfR 2 pH	std units	6.3*
MBfR 1 ORP	mV	-245
MBfR 2 ORP	mV	-838
Nitrate Frequency	Hz	-
Last N Feed	ppm (N)	8.38
Last N R1	ppm (N)	0.57
Last N R2	ppm (N)	1.33
MBfR1 Sparge Rate	mm	240
MBfR2 Sparge Rate	mm	240
Phosphate Pump Settings	spm % stroke	30 30
Phosphate Concentration at Strainer	mg/LPO4	1.3
Aeration Tank Air Flow	scfm	3.2
Air Tank Pressure	psig	2.0
Target Media Filter Flow Rate	gpm	5
Media Filter Inlet Pressure	psig	5.7
Media Filter Outlet Pressure	psig	2.2
Sodium Hypo Pump Settings	spm % stroke	30 100
Coagulant Tank Level	gal	5
Coagulant Pump Settings	ml/min	5
CO2 Cylinder Pressure	psi	90
H2 Cylinder Pressure	psi	89
N2 Pressure	psi	138
N2 Flow Rate	scfm	+
Turbidity (Instrument)	NTU	0.52
Turbidity (OIT)	NTU	0.89

Post Finished Water System Inspection		
Collect while sump is running		
Sump Pump dischrg	psi	
Bag Filter ΔP	psi	2
GAC INFLUENT	psig	29.1
GAC EFFLUENT	psig	5.5
IX-1 Pressure	psig	1.2
Feed Tank Additions		
	H3PO4	Sodium Hypo
Time	12pm	11AM
Initial Tank Level (gal)	4	28
Stock Added	-	-
Type of Water Used For Dilution	-	MED. FLT.
Volume Dilution Added (gal)	-	2
Total Volume Added (gal)	-	2
Final Tank Level (gal)	4	30

INITIATED BACKWASH WHEN DP WAS AT 4.3 PSI

Note: There are 3785 mL per gallon.

Backwash Record			
Backwash start time: <u>12:08</u>			
Backwash duration	min		
Initial Product Tank Level	gal		
Final Product Tank Level	gal		
Time of sample collection:			
Location	(NTU)	TSS Collected?	
Lead Purge 1	-	<input type="checkbox"/> Yes <input checked="" type="checkbox"/> No	
Lead Purge 2	-	<input type="checkbox"/> Yes <input checked="" type="checkbox"/> No	
Lag Purge 1	-	<input type="checkbox"/> Yes <input checked="" type="checkbox"/> No	
Lag Purge 2	-	<input type="checkbox"/> Yes <input checked="" type="checkbox"/> No	
Media Filter	43.1	<input checked="" type="checkbox"/> Yes <input type="checkbox"/> No	

NOTES:
 APT ON SITE TO SWITCH OUT CAMERA DVR SYSTEM. *CDM
 NOTICED LOW PH ON MBfR 2 AND ALERTED APT - TURNED
 OUT THE METER WAS NOT RECEIVING FLOW. UPON
 REINSTATING FLOW, PH STABILIZED AT 7.1.

Inventory		
Type	Check	
H3PO4 Stock (gal)		
Sodium Hypo Stock (gal)		
Additional Field Test Kits Needed?	Dissolved Oxyge	
	Nitrate + Nitrite	
	Nitrite	
	Sulfide	
	Chlorine	
	o-Phosphate	
Calibration Kits needed?	pH	
	ORP	
	Turbidity	

Air Monitoring					
Zero Calibration? <input type="checkbox"/> Yes <input type="checkbox"/> No	Mixed Cylinder	Aeration Tank	MBIR 1	MBIR 2	OIT Area
Time					
Carbon Monoxide (ppm)					
Oxygen (%)					
Methane (% LEL)					
Hydrogen Sulfide (ppm)					

AT 11:00AM,

NOTES CONT:

DECREASED FLOW RATE OF CL₂ PUMP TO 20 SPM (FROM 30) AND TOPPED OFF CL₂ TANK TO DILUTE CHLORINE CONCENTRATION. WAITED 1 HOUR AND TOOK FILTER EFFLUENT RESIDUAL = 1.1 ppm. WAITED 2 HRS AND TOOK PRODUCT TANK RESIDUAL = 1.1 ppm → HEADED IN THE RIGHT DIRECTION. SWITCHED OUT PRESSURE GAUGES ON GAC 2 EFFLUENT W/ GAUGE LOCATED DIRECTLY DOWNSTREAM OF THE BAG FILTERS. NO AIR MONITORING TAKEN TODAY DUE TO ATTEMPTING TO UPLOAD ALL THE PREVIOUS DATA TO THE COMPUTER. ~~HOWEVER WE SHOULD BE WORKING TODAY~~

Date: 1/6/12

Time: 9:30AM

Operator: BERKOFF

Field Samples														
Calibration	pH calibration? <input checked="" type="checkbox"/> Yes <input type="checkbox"/> No Standards: <input checked="" type="checkbox"/> 4 <input checked="" type="checkbox"/> 7 <input type="checkbox"/> 10 Standard Reading: 4: <u>4.00</u> 7: <u>7.05</u> 10: <u>10.12</u>			ORP calibration? <input checked="" type="checkbox"/> Yes <input type="checkbox"/> No Temp (Deg C): <u>14.5</u> Standard Reading: 220: <u>220</u>			Turbidity calibration? <input checked="" type="checkbox"/> Yes <input type="checkbox"/> No Standards: <input type="checkbox"/> 0 <input type="checkbox"/> 20 <input type="checkbox"/> 200 <input type="checkbox"/> 1000 <input type="checkbox"/> 4000 Readings: 0.136: <u>0.155</u> 0.30: <u>0.377</u> 0.50: <u>0.589</u>							
	Lead Reactor: <input type="checkbox"/> MBfR1 <input checked="" type="checkbox"/> MBfR2 SP-100A <input type="checkbox"/> if MBfR1 in LEAD: SP-200B <input type="checkbox"/> if MBfR2 in LEAD: SP-100B <input checked="" type="checkbox"/>			Sample Collection Time: <u>10:30</u>										
Sample Data	Parameter	Units	Influent	*Lead Reactor	*Lag Reactor	Aeration	Media Filter Effluent	Post Sodium Hypo	Finished Water	GAC 1 Effluent	GAC 2 Effluent	IX 1 Effluent	Permitted Outfall	
	pH	(std units)	7.63	7.52	7.60	8.04	7.87		7.95					7.63
	Temperature	(°C)	19.2	20.3	21.3	21.1	21.1		20.6					20.8
	ORP	(mV)	90	-402	-485	-160	30		673					
	Dissolved Oxygen	(mg/L)	9.0	0.3	0.15	7.0	5.5		7.0					
	Nitrate + Nitrite	(mg/L-N)	9.0	2.25	0				0.1					
	Nitrite	(mg/L-N)	0	0.9	0				0					
	Sulfide	(mg/L)	0	0	0.3	0.05			0					
	Turbidity	(NTU)	0.120			1.72	0.178		0.145					
	Chlorine Residual	(mg/L)							1.5	1.2				

* Signifies MBfR 1 or MBfR 2 depending on if reactor is in the lead or lag position - this changes every 96 hours

Note: shaded boxes are to remain blank

Treatment System Inspection		
Outlet Totalizer	gal	7425000
Target Flow Rate	gpm	6
Internal Recycle Rate	gpm	150/120
MBfR 1 pH	std units	7.2
MBfR 2 pH	std units	7.2
MBfR 1 ORP	mV	-408
MBfR 2 ORP	mV	-323
Nitrate Frequency	Hz	-
Last N Feed	ppm (N)	8,338
Last N R1	ppm (N)	0
Last N R2	ppm (N)	1.56
MBfR1 Sparge Rate	mm	240
MBfR2 Sparge Rate	mm	240
Phosphate Pump Settings	spm % stroke	30 30
Phosphate Concentration at Strainer	mg/LPO4	2.5
Aeration Tank Air Flow	scfm	3.1
Air Tank Pressure	psig	2.2
Target Media Filter Flow Rate	gpm	5
Media Filter Inlet Pressure	psig	3.7
Media Filter Outlet Pressure	psig	2.5
Sodium Hypo Pump Settings	spm % stroke	20 100
Coagulant Tank Level	gal	9
Coagulant Pump Settings	ml/min	5
CO2 Cylinder Pressure	psi	88
H2 Cylinder Pressure	psi	89
N2 Pressure	psi	149
N2 Flow Rate	scfm	-
Turbidity (Instrument)	NTU	0.13
Turbidity (OIT)	NTU	0.44

Post Finished Water System Inspection		
Collect while sump is running		
Sump Pump dischrg	psi	
Bag Filter ΔP	psi	2
GAC INFLUENT	psig	10
GAC EFFLUENT	psig	4.5
IX-1 Pressure	psig	1.2
Feed Tank Additions		
	H3PO4	Sodium Hypo
Time	12:00	12:00
Initial Tank Level (gal)	2.5	28
Stock Added	150	0
Type of Water Used For Dilution	INF	MEAFILT.
Volume Dilution Added (gal)	2.5	2
Total Volume Added (gal)	2.5	2
Final Tank Level (gal)	5	30

Note: There are 3785 mL per gallon.

Backwash Record		
Backwash start time:		
Backwash duration	min	
Initial Product Tank Level	gal	
Final Product Tank Level	gal	
Time of sample collection:		
Location	(NTU)	TSS Collected?
Lead Purge 1		<input type="checkbox"/> Yes <input type="checkbox"/> No
Lead Purge 2		<input type="checkbox"/> Yes <input type="checkbox"/> No
Lag Purge 1		<input type="checkbox"/> Yes <input type="checkbox"/> No
Lag Purge 2		<input type="checkbox"/> Yes <input type="checkbox"/> No
Media Filter		<input type="checkbox"/> Yes <input type="checkbox"/> No

NOTES:

LOWERED CHLORINE DOSING PUMP TO 17 SPM @ 10:40AM DUE TO RESIDUAL IN PRODUCT STILL READING ABOVE 1.0. AFTER TWO HOURS THE PRODUCT STILL READ ABOVE 1.0 SO I TOPPED OFF THE CL2 TANK AND LOWERED THE PUMP TO 15 SPM.

Inventory		
Type	Check	
H3PO4 Stock (gal)	3.5	
Sodium Hypo Stock (gal)	30+	
Additional Field Test Kits Needed?	Dissolved Oxygen	5/3
	Nitrate + Nitrite	5
	Nitrite	5
	Sulfide	1
	Chlorine	4
	o-Phosphate	3
Calibration kits needed?	pH	✓
	ORP	✓
	Turbidity	✓

Air Monitoring					
Zero Calibration? <input checked="" type="checkbox"/> Yes <input type="checkbox"/> No	Mixed Cylinder	Aeration Tank LID CLOSED	AERATION LID OPEN	AERATION LID CLOSED	OIT Area
Time	9:45	10:07	10:27	10:47	
Carbon Monoxide (ppm)	49	12	53	2	
Oxygen (%)	12	21.3	21.2	21.3	
Methane (% LEL)	49	0	0	0	
Hydrogen Sulfide (ppm)	25	0	0	0	

NOTES CONT.:

Date: 1/9/12

Time: 9:00

Operator: ARUCAN

Field Samples														
Calibration	pH calibration? <input checked="" type="checkbox"/> Yes <input type="checkbox"/> No Standards: <input type="checkbox"/> 4 <input type="checkbox"/> 7 <input type="checkbox"/> 10 Standard Reading: 4: <u>4.09</u> 7: <u>7.04</u> 10: <u>10.12</u>			ORP calibration? <input checked="" type="checkbox"/> Yes <input type="checkbox"/> No Temp (Deg C): <u>19.1</u> Standard Reading: 220: <u>226</u>			Turbidity calibration? <input checked="" type="checkbox"/> Yes <input type="checkbox"/> No Standards: <input type="checkbox"/> 10 <input type="checkbox"/> 20 <input type="checkbox"/> 200 <input type="checkbox"/> 1000 <input type="checkbox"/> 4000 Readings: 0.136: <u>0.154</u> 0.30: <u>0.337</u> 0.50: <u>0.542</u>							
	Lead Reactor: <input checked="" type="checkbox"/> MBfR1 <input type="checkbox"/> MBfR2		Lead Sample SP-100A <input checked="" type="checkbox"/> Lag Sample if MBfR1 in LEAD: SP-200B <input checked="" type="checkbox"/> if MBfR2 in LEAD: SP-100B <input type="checkbox"/>		Sample Collection Time: <u>12:00</u>									
Sample Data	Parameter	Units	Influent	*Lead Reactor	*Lag Reactor	Aeration	Media Filter Effluent	Post Sodium Hypo	Finished Water	GAC 1 Effluent	GAC 2 Effluent	IX 1 Effluent	Permitted Outfall	
	pH	(std units)	7.44	7.52	7.64	7.86	7.82			7.85				7.49
	Temperature	(°C)	18.8	20.4	21.6	21.4	21.3			21.1				21.6
	ORP	(mV)	140	-353	-528	-182	-40			385				
	Dissolved Oxygen	(mg/L)	8.5	0.3	0.1	5.5	6			7				
	Nitrate + Nitrite	(mg/L-N)	8.75	1.5	0					0.4				
	Nitrite	(mg/L-N)	0	0.3	0					0				
	Sulfide	(mg/L)	0	0	1.0	0.4				0				
	Turbidity	(NTU)	0.199			1.76	0.163			0.341				
	Chlorine Residual	(mg/L)							1.5	1.0				

Treatment System Inspection		
Outlet Totalizer	gal	745400
Target Flow Rate	gpm	6
Internal Recycle Rate	gpm	150/120
MBfR 1 pH	std units	7.2
MBfR 2 pH	std units	7.2
MBfR 1 ORP	mV	-247
MBfR 2 ORP	mV	-688
Nitrate Frequency	Hz	---
Last N Feed	ppm (N)	8.40
Last N R1	ppm (N)	1.41
Last N R2	ppm (N)	0.07
MBfR1 Sparge Rate	mm	240
MBfR2 Sparge Rate	mm	240
Phosphate Pump Settings	spm	20
	% stroke	30
Phosphate Concentration at Strainer	mg/LPO4	1.5
Aeration Tank Air Flow	scfm	3.2
Air Tank Pressure	psig	2.1
Target Media Filter Flow Rate	gpm	5.0
Media Filter Inlet Pressure	psig	5.5
Media Filter Outlet Pressure	psig	2.4
Sodium Hypo Pump Settings	spm	15
	% stroke	100
Coagulant Tank Level	gal	4
Coagulant Pump Settings	mL/min	5
CO2 Cylinder Pressure	psi	92
H2 Cylinder Pressure	psi	91
N2 Pressure	psi	143
N2 Flow Rate	scfm	
Turbidity (Instrument)	NTU	0.13
Turbidity (OIT)	NTU	0.12

Post Finished Water System Inspection		
Collect while sump is running		
Sump Pump dischrg	psi	17
Bag Filter ΔP	psi	2
GAC Influent	psig	10
GAC Effluent	psig	5
IX-1 Pressure	psig	15
Feed Tank Additions		
	H3PO4	Sodium Hypo
Time	1:30	1:45
Initial Tank Level (gal)	2.2	2.4
Stock Added	150	---
Type of Water Used For Dilution	WFL	---
Volume Dilution Added (gal)	2.3	---
Total Volume Added (gal)	2.3	---
Final Tank Level (gal)	4.5	2.4

Note: There are 3785 mL per gallon.

Backwash Record		
Backwash start time:		
Backwash duration	min	
Initial Product Tank Level	gal	
Final Product Tank Level	gal	
Time of sample collection:		
Location	(NTU)	TSS Collected?
Lead Purge 1		<input type="checkbox"/> Yes <input type="checkbox"/> No
Lead Purge 2		<input type="checkbox"/> Yes <input type="checkbox"/> No
Lag Purge 1		<input type="checkbox"/> Yes <input type="checkbox"/> No
Lag Purge 2		<input type="checkbox"/> Yes <input type="checkbox"/> No
Media Filter		<input type="checkbox"/> Yes <input type="checkbox"/> No

NOTES:
 WINDY TODAY. CDM PERFORMING AIR MONITORING TODAY.
 WEEKLY AND DUPLICATE SAMPLES WERE TAKEN.

Inventory		
Type	Check	
H3PO4 Stock (gal)	2.5	
Sodium Hypo Stock (gal)	20+	
Additional Field Test Kits Needed?	Dissolved Oxyge	5/3
	Nitrate + Nitrite	5
	Nitrite	5
	Sulfide	1
	Chlorine	4
Calibration kits needed?	o-Phosphate	2
	pH	✓
	ORP	✓
	Turbidity	✓

Date: 1/11/12

Time: 9:15 AM

Operator: BERKOFF

Field Samples													
Calibration	pH calibration? <input checked="" type="checkbox"/> Yes <input type="checkbox"/> No Standards: <input checked="" type="checkbox"/> 4 <input checked="" type="checkbox"/> 7 <input checked="" type="checkbox"/> 10 Standard Reading: 4: <u>4.00</u> 7: <u>7.00</u> 10: <u>10.18</u>				ORP calibration? <input checked="" type="checkbox"/> Yes <input type="checkbox"/> No Temp (Deg C): <u>11.3</u> Standard Reading: 220: <u>220</u>				Turbidity calibration? <input checked="" type="checkbox"/> Yes <input type="checkbox"/> No Standards: <input checked="" type="checkbox"/> 10 <input checked="" type="checkbox"/> 20 <input checked="" type="checkbox"/> 200 <input checked="" type="checkbox"/> 1000 <input checked="" type="checkbox"/> 4000 Readings: 0.136: <u>0.178</u> 0.30: <u>0.235</u> 0.50: <u>0.564</u>				
	Lead Sample / Lag Sample Lead Reactor: <input type="checkbox"/> MBR1 <input checked="" type="checkbox"/> MBR2 SP-100A <input checked="" type="checkbox"/> if MBR1 in LEAD; SP-200B <input checked="" type="checkbox"/> if MBR2 in LEAD; SP-100B <input checked="" type="checkbox"/>			Sample Collection Time: <u>10 AM</u>									
Sample Data	Parameter	Units	Influent	*Lead Reactor	*Lag Reactor	Aeration	Media Filter Effluent	Post Sodium Hypo	Finished Water	GAC 1 Effluent	GAC 2 Effluent	IX 1 Effluent	Permitted Outfall
	pH	(std units)	7.60	7.43	7.55	8.02	7.89		7.94				7.67
	Temperature	(°C)	18.6	19.8	21.1	20.8	20.7		20.3				19.8
	ORP	(mV)	167	8	-424	-31	103		543				
	Dissolved Oxygen	(mg/L)	9.0	0.3	0.15	7.0	7.0		7.0				
	Nitrate + Nitrite	(mg/L-N)	8.5	1.40	0.25				0.25				
	Nitrite	(mg/L-N)	0	0.20	0.25				0				
	Sulfide	(mg/L)	0	0	0.05	0			0				
	Turbidity	(NTU)	0.120			1.26	0.11		0.126				
	Chlorine Residual	(mg/L)							1.1	0.9			

* Signifies MBR1 or MBR2 depending on if reactor is in the lead or lag position - this changes every 96 hours

Note: shaded boxes are to remain blank

Post Finished Water System Inspection		
Collect while sump is running		
Sump Pump dischrg	psi	
Bag Filter ΔP	psi	
GAC Influent	psig	
GAC Effluent	psig	
IX-1 Pressure	psig	
Feed Tank Additions		
	H3PO4	Sodium Hypo
Time	<u>10:00</u>	<u>10:00</u>
Initial Tank Level (gal)	<u>3.1</u>	<u>2.5</u>
Stock Added	-	-
Type of Water Used For Dilution	-	-
Volume Dilution Added (gal)	-	-
Total Volume Added (gal)	-	-
Final Tank Level (gal)	<u>3.1</u>	<u>2.5</u>

Note: There are 3785 mL per gallon.

Backwash Record			
Backwash start time: <u>11:57 AM</u>			
Backwash duration	min		
Initial Product Tank Level	gal		
Final Product Tank Level	gal		
Time of sample collection: <u>12:00 - 12:23</u>			
Location	(NTU)	TSS Collected?	
Lead Purge 1	<u>8.34</u>	<input checked="" type="checkbox"/> Yes <input type="checkbox"/> No	
Lead Purge 2	<u>18</u>	<input checked="" type="checkbox"/> Yes <input type="checkbox"/> No	
Lag Purge 1	<u>44</u>	<input checked="" type="checkbox"/> Yes <input type="checkbox"/> No	
Lag Purge 2	<u>19</u>	<input checked="" type="checkbox"/> Yes <input type="checkbox"/> No	
Media Filter	-	<input type="checkbox"/> Yes <input checked="" type="checkbox"/> No	
NOTES: <u>FINAL DAY OF STEADY STATE MONITORING.</u>			

Inventory		
	Type	Check
	H3PO4 Stock (gal)	
	Sodium Hypo Stock (gal)	
Additional Field Test Kits Needed?	Dissolved Oxygen	
	Nitrate + Nitrite	
	Nitrite	
	Sulfide	
	o-Phosphate	
Calibration kits needed?	pH	
	ORP	
	Turbidity	

Treatment System Inspection		
Outlet Totalizer	gal	<u>74686.00</u>
Target Flow Rate	gpm	<u>6</u>
Internal Recycle Rate	gpm	<u>150/120</u>
MBfR 1 pH	std units	<u>7.2</u>
MBfR 2 pH	std units	<u>7.0</u>
MBfR 1 ORP	mV	<u>-476</u>
MBfR 2 ORP	mV	<u>-193</u>
Nitrate Frequency	Hz	
Last N Feed	ppm (N)	<u>8.39</u>
Last N R1	ppm (N)	<u>0.06</u>
Last N R2	ppm (N)	<u>3.08</u>
MBfR1 Sparge Rate	mm	<u>240</u>
MBfR2 Sparge Rate	mm	<u>240</u>
Phosphate Pump Settings	spm	<u>30</u>
	% stroke	<u>30</u>
Phosphate Concentration at Strainer	mg/LPO4	<u>1.15</u>
Aeration Tank Air Flow	scfm	<u>30</u>
Air Tank Pressure	psig	<u>2.1</u>
Target Media Filter Flow Rate	gpm	<u>5</u>
Media Filter Inlet Pressure	psig	<u>2.6</u>
Media Filter Outlet Pressure	psig	<u>2.3</u>
Sodium Hypo Pump Settings	spm	<u>15</u>
	% stroke	<u>100</u>
Coagulant Tank Level	gal	<u>8</u>
Coagulant Pump Settings	ml/min	<u>5</u>
CO2 Cylinder Pressure	psi	<u>90</u>
H2 Cylinder Pressure	psi	<u>89</u>
N2 Pressure	psi	<u>136</u>
N2 Flow Rate	scfm	<u>-</u>
Turbidity (Instrument)	NTU	<u>0.07</u>
Turbidity (OIT)	NTU	<u>0.45</u>

Date: 1/12/12

Time: 8:30 AM

Operator: BERKOFF

8:30 AM

Field Samples														
Calibration	pH calibration? <input type="checkbox"/> Yes <input type="checkbox"/> No Standards: <input type="checkbox"/> 4 <input type="checkbox"/> 7 <input type="checkbox"/> 10 Standard Reading: 4: _____ 7: _____ 10: _____			ORP calibration? <input type="checkbox"/> Yes <input type="checkbox"/> No Temp (Deg C): _____ Standard Reading: 220: _____			Turbidity calibration? <input type="checkbox"/> Yes <input type="checkbox"/> No Standards: <input type="checkbox"/> 0 <input type="checkbox"/> 20 <input type="checkbox"/> 200 <input type="checkbox"/> 1000 <input type="checkbox"/> 4000 Readings: 0.136: _____ 0.30: _____ 0.50: _____							
	Lead Sample <input type="checkbox"/> Lag Sample <input type="checkbox"/>				Sample Collection Time: _____									
Lead Reactor: <input type="checkbox"/> MBfR1 <input checked="" type="checkbox"/> MBfR2 SP-100A <input type="checkbox"/> if MBfR1 in LEAD: SP-200B <input type="checkbox"/> if MBfR2 in LEAD: SP-100B <input checked="" type="checkbox"/>														
Sample Data	Parameter	Units	Influent	*Lead Reactor	*Lag Reactor	Aeration	Media Filter Effluent	Post Sodium Hypo	Finished Water	GAC 1 Effluent	GAC 2 Effluent	IX 1 Effluent	Permitted Outfall	
	pH	(std units)												
	Temperature	(°C)												
	ORP	(mV)												
	Dissolved Oxygen	(mg/L)												
	Nitrate + Nitrite	(mg/L-N)												
	Nitrite	(mg/L-N)												
	Sulfide	(mg/L)												
	Turbidity	(NTU)												
	Chlorine Residual	(mg/L)								0.9				

Treatment System Inspection		
Outlet Totalizer	gal	747700
Target Flow Rate	gpm	150 6
Internal Recycle Rate	gpm	150/90
MBfR 1 pH	std units	6.6
MBfR 2 pH	std units	6.8
MBfR 1 ORP	mV	-189
MBfR 2 ORP	mV	-37
Nitrate Frequency	Hz	-
Last N Feed	ppm (N)	8.36
Last N R1	ppm (N)	5.36
Last N R2	ppm (N)	7.49
MBfR1 Sparge Rate	mm	240
MBfR2 Sparge Rate	mm	240
Phosphate Pump Settings	spm	20
	% stroke	30
Phosphate Concentration at Strainer	mg/LPO4	1.5
Aeration Tank Air Flow	scfm	3.1
Air Tank Pressure	psig	2.0
Target Media Filter Flow Rate	gpm	5
Media Filter Inlet Pressure	psig	7.5
Media Filter Outlet Pressure	psig	2.3
Sodium Hypo Pump Settings	spm	15
	% stroke	100
Coagulant Tank Level	gal	6
Coagulant Pump Settings	ml/min	5
CO2 Cylinder Pressure	psi	90
H2 Cylinder Pressure	psi	88
N2 Pressure	psi	139
N2 Flow Rate	scfm	1.5
Turbidity (Instrument)	NTU	0.15
Turbidity (OIT)	NTU	0.54

Post Finished Water System Inspection		
Collect while sump is running		
Sump Pump dischrg	psi	
Bag Filter ΔP	psi	
GAC Influent	psig	
GAC Effluent	psig	
IX-1 Pressure	psig	
Feed Tank Additions		
	H3PO4	Sodium Hypo
Time		
Initial Tank Level (gal)		
Stock Added		
Type of Water Used For Dilution		
Volume Dilution Added (gal)		
Total Volume Added (gal)		
Final Tank Level (gal)		

Note: There are 3785 mL per gallon.

Backwash Record		
Backwash start time:	10:10	
Backwash duration	min	
Initial Product Tank Level	gal	
Final Product Tank Level	gal	
Time of sample collection:	10:12	
Location	(NTU)	TSS Collected?
Lead Purge 1	-	<input type="checkbox"/> Yes <input checked="" type="checkbox"/> No
Lead Purge 2	-	<input type="checkbox"/> Yes <input checked="" type="checkbox"/> No
Lag Purge 1	-	<input type="checkbox"/> Yes <input checked="" type="checkbox"/> No
Lag Purge 2	-	<input type="checkbox"/> Yes <input checked="" type="checkbox"/> No
Media Filter	37	<input checked="" type="checkbox"/> Yes <input type="checkbox"/> No

NOTES:
 CHALLENGE PHASE: APT TURNED OFF GASES AT 4AM THEN TURNED THEM ON AT 8AM. TOOK PH READINGS ON LEAD AND LAG @ 8:15AM, LEAD pH=7.07 @ 19.3°C. LAG pH=7.12 @ 20.3 → COMPARE TO OIT READINGS: LEAD pH=6.8 LAG pH=6.6

Inventory	
Type	Check
H3PO4 Stock (gal)	
Sodium Hypo Stock (gal)	
Additional Field Test Kits Needed?	Dissolved Oxygen
	Nitrate + Nitrite
	Nitrite
	Sulfide
	Chlorine
Calibration Kits needed?	o-Phosphate
	pH
	ORP
	Turbidity

Air Monitoring					
Zero Calibration? <input type="checkbox"/> Yes <input type="checkbox"/> No	Mixed Cylinder	Aeration Tank	MBfR 1	MBfR 2	OIT Area
Time					
Carbon Monoxide (ppm)					
Oxygen (%)					
Methane (% LEL)					
Hydrogen Sulfide (ppm)					

NOTES CONT.:

TOOK PH ON LAG @ 10:15AM = 7.81 @ 20.7°C (OIT = 7.2). AT 10:25AM PH ON LEAD = 7.49 @ 19.6°C.

Date: 01/13/12

Time: 12:00

Operator: ARUCAN

Field Samples

pH calibration? <input type="checkbox"/> Yes <input type="checkbox"/> No Standards: <input type="checkbox"/> 4 <input type="checkbox"/> 7 <input type="checkbox"/> 10 Standard Reading: 4: _____ 7: _____ 10: _____		ORP calibration? <input type="checkbox"/> Yes <input type="checkbox"/> No Temp (Deg C): _____ Standard Reading: 220: _____		Turbidity calibration? <input type="checkbox"/> Yes <input type="checkbox"/> No Standards: <input type="checkbox"/> 0 <input type="checkbox"/> 20 <input type="checkbox"/> 200 <input type="checkbox"/> 1000 <input type="checkbox"/> 4000 Readings: 0.136: _____ 0.30: _____ 0.50: _____								
Lead Reactor: <input type="checkbox"/> MBR1 <input checked="" type="checkbox"/> MBR2		Lag Sample <input type="checkbox"/> if MBR1 in LEAD: SP-200B <input type="checkbox"/> <input checked="" type="checkbox"/> if MBR2 in LEAD: SP-100A <input checked="" type="checkbox"/> SP-100B		Sample Collection Time: 12:30								
Parameter	Units	Influent	*Lead Reactor	*Lag Reactor	Aeration	Media Filter Effluent	Post Sodium Hypo	Finished Water	GAC 1 Effluent	GAC 2 Effluent	IX 1 Effluent	Permitted Outfall
pH	(std units)											
Temperature	(°C)											
ORP	(mV)											
Dissolved Oxygen	(mg/L)											
Nitrate + Nitrite	(mg/L-N)											
Nitrite	(mg/L-N)											
Sulfide	(mg/L)											
Turbidity	(NTU)											
Chlorine Residual	(mg/L)							0.8				

* Signifies MBR 1 or MBR 2 depending on if reactor is in the lead or lag position - this changes every 96 hours

Note: shaded boxes are to remain blank

Treatment System Inspection

Outlet Totalizer	gal	7487400
Target Flow Rate	gpm	6
Internal Recycle Rate	gpm	150/120
MBfR 1 pH	std units	7.2
MBfR 2 pH	std units	7.2
MBfR 1 ORP	mV	-410
MBfR 2 ORP	mV	-315
Nitrate Frequency	Hz	---
Last N Feed	ppm (N)	8.36
Last N R1	ppm (N)	0.04
Last N R2	ppm (N)	2.21
MBfR1 Sparge Rate	mm	240
MBfR2 Sparge Rate	mm	240
Phosphate Pump Settings	spm % stroke	20 30
Phosphate Concentration at Strainer	mg/LPO4	1.2
Aeration Tank Air Flow	scfm	3.2
Air Tank Pressure	psig	2.1
Target Media Filter Flow Rate	gpm	5
Media Filter Inlet Pressure	psig	6.3
Media Filter Outlet Pressure	psig	2.3
Sodium Hypo Pump Settings	spm % stroke	15 100
Coagulant Tank Level	gal	5
Coagulant Pump Settings	ml/min	5
CO2 Cylinder Pressure	psi	92
H2 Cylinder Pressure	psi	91
N2 Pressure	psi	114
N2 Flow Rate	scfm	133
Turbidity (Instrument)	NTU	0.14
Turbidity (OIT)	NTU	0.13

Post Finished Water System Inspection

Collect while sump is running

Sump Pump dischrg	psi	16
Bag Filter ΔP	psi	4
GAC Influent	psig	11
GAC Effluent	psig	5
IX-1 Pressure	psig	1.6

Feed Tank Additions

	H3PO4	Sodium Hypo
Time	1:00	1:15
Initial Tank Level (gal)	1.5	20
Stock Added	150ml	---
Volume of Water Used For Dilution	INFL.	---
Volume Dilution Added (gal)	3.5	---
Total Volume Added (gal)	3.5	---
Total Tank Level (gal)	5.0	20

Note: There are 3785 mL per gallon.

Backwash Record

Backwash start time: _____

Backwash duration	min	
Initial Product Tank Level	gal	
Final Product Tank Level	gal	

Time of sample collection:

Location	(NTU)	TSS Collected?
Lead Purge 1		<input type="checkbox"/> Yes <input type="checkbox"/> No
Lead Purge 2		<input type="checkbox"/> Yes <input type="checkbox"/> No
Lag Purge 1		<input type="checkbox"/> Yes <input type="checkbox"/> No
Lag Purge 2		<input type="checkbox"/> Yes <input type="checkbox"/> No
Media Filter		<input type="checkbox"/> Yes <input type="checkbox"/> No

NOTES: AND DUPLICATE

COM ON SITE TO TAKE DAILY SAMPLE @ 12:30

Date: 01/16/12

Time: 8:15

Operator: ARUCAN

TAKEN @ 8:20

Field Samples													
Calibration	pH calibration? <input type="checkbox"/> Yes <input checked="" type="checkbox"/> No Standards: <input type="checkbox"/> 4 <input type="checkbox"/> 7 <input type="checkbox"/> 10 Standard Reading: 4: _____ 7: _____ 10: _____				ORP calibration? <input type="checkbox"/> Yes <input checked="" type="checkbox"/> No Temp (Deg C): _____ Standard Reading: 220: _____				Turbidity calibration? <input type="checkbox"/> Yes <input checked="" type="checkbox"/> No Standards: <input type="checkbox"/> 0 <input type="checkbox"/> 20 <input type="checkbox"/> 200 <input type="checkbox"/> 1000 <input type="checkbox"/> 4000 Readings: 0.136: _____ 0.30: _____ 0.50: _____				
	Lead Reactor: <input checked="" type="checkbox"/> MfBR1 <input type="checkbox"/> MfBR2			Lag Sample <input checked="" type="checkbox"/> SP-100A			Lag Sample <input type="checkbox"/> if MfBR1 in LEAD: SP-200B <input checked="" type="checkbox"/> if MfBR2 in LEAD: SP-100B			Sample Collection Time: _____			
Sample Data	Parameter	Units	Influent	*Lead Reactor	*Lag Reactor	Aeration	Media Filter Effluent	Post Sodium Hypo	Finished Water	GAC 1 Effluent	GAC 2 Effluent	IX 1 Effluent	Permitted Outfall
	pH	(std units)											7.58
	Temperature	(°C)											20.0
	ORP	(mV)											
	Dissolved Oxygen	(mg/L)											
	Nitrate + Nitrite	(mg/L-N)											
	Nitrite	(mg/L-N)											
	Sulfide	(mg/L)											
	Turbidity	(NTU)											
	Chlorine Residual	(mg/L)						0.4	0.1				

* Signifies MfBR 1 or MfBR 2 depending on if reactor is in the lead or lag position - this changes every 96 hours

Note: shaded boxes are to remain blank

Post Finished Water System Inspection		
Collect while sump is running		
Sump Pump dischrg	psi	16
Bag Filter ΔP	psi	4
GAC Influent	psig	12
GAC Effluent	psig	5
IX-1 Pressure	psig	1.7
Feed Tank Additions		
	H3PO4	Sodium Hypo
Time	2:45	1:30
Initial Tank Level (gal)	2.5	18
Stock Added	150 ml	—
Type of Water Used For Dilution	WF.	—
Volume Dilution Added (gal)	2.5	—
Total Volume Added (gal)	2.5	—
Final Tank Level (gal)	5.0	18

Note: There are 3785 mL per gallon.

Backwash Record		
Backwash start time: _____		
Backwash duration	min	
Initial Product Tank Level	gal	
Final Product Tank Level	gal	
Time of sample collection:		
Location	(NTU)	TSS Collected?
Lead Purge 1		<input checked="" type="checkbox"/> Yes <input type="checkbox"/> No
Lead Purge 2		<input type="checkbox"/> Yes <input type="checkbox"/> No
Lag Purge 1		<input type="checkbox"/> Yes <input type="checkbox"/> No
Lag Purge 2		<input type="checkbox"/> Yes <input type="checkbox"/> No
Media Filter		<input type="checkbox"/> Yes <input type="checkbox"/> No

NOTES:
 CDM ONSITE @ 8:15. APT TURNED H₂, N₂ & CO₂ SOLENOIDS IN THE "ON" POSITION TO START FEEDING THE SYSTEM. FIRST SAMPLE TAKEN @ 8:32. CDM ALSO TOOK SAMPLES AT MEDIA FILTER AND ALSO TO DUPLICATE SAMPLES

Treatment System Inspection		
Outlet Totalizer	gal	751360
Target Flow Rate	gpm	6
Internal Recycle Rate	gpm	150/90
MBfR 1 pH	std units	6.5
MBfR 2 pH	std units	6.4
MBfR 1 ORP	mV	-46
MBfR 2 ORP	mV	-22
Nitrate Frequency	Hz	—
Last N Feed	ppm (N)	8.30
Last N R1	ppm (N)	8.20
Last N R2	ppm (N)	7.93
MBfR1 Sparge Rate	mm	240
MBfR2 Sparge Rate	mm	240
Phosphate Pump Settings	spm % stroke	30 100
Phosphate Concentration at Strainer	mg/LPO4	1.7
Aeration Tank Air Flow	scfm	3.2
Air Tank Pressure	psig	2.1
Target Media Filter Flow Rate	gpm	5
Media Filter Inlet Pressure	psig	4.4
Media Filter Outlet Pressure	psig	2.2
Sodium Hypo Pump Settings	spm % stroke	15 100
Coagulant Tank Level	gal	0
Coagulant Pump Settings	ml/min	OFF
CO2 Cylinder Pressure	psi	91
H2 Cylinder Pressure	psi	92
N2 Pressure	psi	134
N2 Flow Rate	scfm	—
Turbidity (Instrument)	NTU	6.06
Turbidity (OIT)	NTU	0.06

Air Monitoring					
Zero Calibration? <input type="checkbox"/> Yes <input type="checkbox"/> No	Mixed Cylinder	Aeration Tank	MBfR 1	MBfR 2	OIT Area
Time					
Carbon Monoxide (ppm)					
Oxygen (%)					
Methane (% LEL)					
Hydrogen Sulfide (ppm)					

SAMPLES	TIME	TIME
FINISH-2-1	8:32	
" - 2-2	9:32	
- 2-3	10:32	
- 2-4	11:32	
- 2-5	12:32	
- 2-6	1:32	
- 2-7	2:32	
- 2-8	3:32	
- 2-9	4:32	
- 2-10	5:32	
MEDIA FILTER-2-9	4:32	
MEDIA FILTER-2-10	5:32	
DUPPLICATE 1	3:30	
DUP. 2	4:32	
DUP. 3	4:32	
DUP 4	5:32	

NOTES CONT.:

FILTER AID IS EMPTY AND APT WAS CONTACTED FOR REFILL

DUPPLICATE	LOCATION	TIME
1	FINISH	3:30
2	FINISH	4:32
3	MEDIA FILTER	4:32
4	MEDIA FILTER	5:32

NITRATE READINGS		
TIME	LEAD	LAG
8:30	8.20	7.93
10:30	7.99	3.99
11:30	7.12	2.40
12:30	6.48	0.66
1:30	4.23	0.50
2:30	3.15	0.08
3:30	2.08	0.04
4:30		

Date: 01/17/12

Time: 11:30

Operator: ARUCAN

Field Samples													
Calibration	pH calibration? <input checked="" type="checkbox"/> Yes <input type="checkbox"/> No Standards: <input checked="" type="checkbox"/> 4 <input checked="" type="checkbox"/> 7 <input type="checkbox"/> 10 Standard Reading: 4: <u>4.09</u> 7: <u>7.07</u> 10: <u>10.16</u>				ORP calibration? <input type="checkbox"/> Yes <input checked="" type="checkbox"/> No Temp (Deg C): _____ Standard Reading: 220: _____				Turbidity calibration? <input type="checkbox"/> Yes <input checked="" type="checkbox"/> No Standards: <input type="checkbox"/> 0 <input type="checkbox"/> 20 <input type="checkbox"/> 200 <input type="checkbox"/> 1000 <input type="checkbox"/> 4000 Readings: 0.136: _____ 0.30: _____ 0.50: _____				
	Lead Reactor: <input type="checkbox"/> MfBR1 <input type="checkbox"/> MfBR2 <input type="checkbox"/> SP-100A <input type="checkbox"/> if MfBR1 in LEAD: SP-200B <input type="checkbox"/> if MfBR2 in LEAD: SP-100B <input type="checkbox"/>			Lag Sample			Sample Collection Time: <u>2:00</u>						
Sample Data	Parameter	Units	Influent	*Lead Reactor	*Lag Reactor	Aeration	Media Filter Effluent	Post Sodium Hypo	Finished Water	GAC 1 Effluent	GAC 2 Effluent	IX 1 Effluent	Permitted Outfall
	pH	(std units)											7.51
	Temperature	(°C)											20.1
	ORP	(mV)											
	Dissolved Oxygen	(mg/L)											
	Nitrate + Nitrite	(mg/L-N)											
	Nitrite	(mg/L-N)											
	Sulfide	(mg/L)											
	Turbidity	(NTU)											
	Chlorine Residual	(mg/L)							0.4	0.1			

* Signifies MfBR 1 or MfBR 2 depending on if reactor is in the lead or lag position - this changes every 96 hours

Note: shaded boxes are to remain blank

Post Finished Water System Inspection		
Collect while sump is running		
Sump Pump dischrg	psi	
Bag Filter ΔP	psi	
GAC Influent	psig	
GAC Effluent	psig	
IX-1 Pressure	psig	
Feed Tank Additions		
	H3PO4	Sodium Hypo
Time		
Initial Tank Level (gal)	4.5	17
Stock Added	—	—
Type of Water Used For Dilution	—	—
Volume Dilution Added (gal)	—	—
Total Volume Added (gal)	—	—
Final Tank Level (gal)	4.5	17

Note: There are 3785 mL per gallon.

Backwash Record		
Backwash start time: _____		
Backwash duration	min	
Initial Product Tank Level	gal	
Final Product Tank Level	gal	
Time of sample collection:		
Location	(NTU)	TSS Collected?
Lead Purge 1		<input checked="" type="checkbox"/> Yes <input type="checkbox"/> No
Lead Purge 2		<input type="checkbox"/> Yes <input type="checkbox"/> No
Lag Purge 1		<input type="checkbox"/> Yes <input type="checkbox"/> No
Lag Purge 2		<input type="checkbox"/> Yes <input type="checkbox"/> No
Media Filter		<input type="checkbox"/> Yes <input type="checkbox"/> No

NOTES:
CDM CHANGED BACKWASH DP VALUE TO 10 TO DELAY FOR SAMPLING. CDM HAS CHANGED DP BACK TO 5 PSI. A FILTERED BACKWASH WAS INITIATED AT 1:15.

Treatment System Inspection		
Outlet Totalizer	gal	752,200
Target Flow Rate	gpm	6
Internal Recycle Rate	gpm	150/90
MfBR 1 pH	std units	7.9
MfBR 2 pH	std units	7.2
MfBR 1 ORP	mV	-217
MfBR 2 ORP	mV	-640
Nitrate Frequency	Hz	—
Last N Feed	ppm (N)	8.33
Last N R1	ppm (N)	1.67
Last N R2	ppm (N)	0.02
MfBR1 Sparge Rate	mm	240
MfBR2 Sparge Rate	mm	240
Phosphate Pump Settings	spm % stroke	20 30
Phosphate Concentration at Strainer	mg/LPO4	2.0
Aeration Tank Air Flow	scfm	3.2
Air Tank Pressure	psig	2.1
Target Media Filter Flow Rate	gpm	5
Media Filter Inlet Pressure	psig	6.4
Media Filter Outlet Pressure	psig	2.2
Sodium Hypo Pump Settings	spm % stroke	15 100
Coagulant Tank Level	gal	10
Coagulant Pump Settings	ml/min	5
CO2 Cylinder Pressure	psi	92
H2 Cylinder Pressure	psi	90
N2 Pressure	psi	132
N2 Flow Rate	scfm	—
Turbidity (Instrument)	NTU	0.12
Turbidity (OIT)	NTU	0.12

Air Monitoring					
Zero Calibration? <input type="checkbox"/> Yes <input type="checkbox"/> No	Mixed Cylinder	Aeration Tank	MBfR 1	MBfR 2	OIT Area
Time					
Carbon Monoxide (ppm)					
Oxygen (%)					
Methane (% LEL)					
Hydrogen Sulfide (ppm)					

NOTES CONT.:

Date: 1/18/12

Time: 12:45

Operator: BEROKOFF

Field Samples

Calibration	pH calibration? <input type="checkbox"/> Yes <input checked="" type="checkbox"/> No		ORP calibration? <input type="checkbox"/> Yes <input checked="" type="checkbox"/> No		Turbidity calibration? <input type="checkbox"/> Yes <input checked="" type="checkbox"/> No							
	Standards: <input type="checkbox"/> 4 <input type="checkbox"/> 7 <input type="checkbox"/> 10 Standard Reading:		Temp (Deg C):		Standards: <input type="checkbox"/> 0 <input type="checkbox"/> 20 <input type="checkbox"/> 200 <input type="checkbox"/> 1000 <input type="checkbox"/> 4000 Readings:							
4: _____ 7: _____ 10: _____		Standard Reading: 220: _____		0.136: _____ 0.30: _____ 0.50: _____								
Lead Reactor: <input checked="" type="checkbox"/> MBfR1 <input type="checkbox"/> MBfR2		Lead Sample Lag Sample SP-100A <input type="checkbox"/> if MBfR1 in LEAD: SP-200B <input type="checkbox"/> if MBfR2 in LEAD: SP-100B <input type="checkbox"/>		Sample Collection Time: <u>1pm</u>								
Parameter	Units	Influent	*Lead Reactor	*Lag Reactor	Aeration	Media Filter Effluent	Post Sodium Hypo	Finished Water	GAC 1 Effluent	GAC 2 Effluent	IX 1 Effluent	Permitted Outfall
pH	(std units)											7.68
Temperature	(°C)											19.7
ORP	(mV)											
Dissolved Oxygen	(mg/L)											
Nitrate + Nitrite	(mg/L-N)											
Nitrite	(mg/L-N)											
Sulfide	(mg/L)											
Turbidity	(NTU)											
Chlorine Residual	(mg/L)							0.7				

* Signifies MBfR 1 or MBfR 2 depending on if reactor is in the lead or lag position - this changes every 96 hours

Note: shaded boxes are to remain blank

Outlet Totalizer	gal	7530200
Target Flow Rate	gpm	6
Internal Recycle Rate	gpm	150/90
MBfR 1 pH	std units	7.2
MBfR 2 pH	std units	7.2
MBfR 1 ORP	mV	-290
MBfR 2 ORP	mV	-628
Nitrate Frequency	Hz	-
Last N Feed	ppm (N)	8.34
Last N R1	ppm (N)	1.28
Last N R2	ppm (N)	0.11
MBfR1 Sparge Rate	mm	240
MBfR2 Sparge Rate	mm	240
Phosphate Pump Settings	spm	20
	% stroke	30
Phosphate Concentration at Strainer	mg/LPO4	1.2
Aeration Tank Air Flow	scfm	3.1
Air Tank Pressure	psig	2.0
Target Media Filter Flow Rate	gpm	5
Media Filter Inlet Pressure	psig	2.2
Media Filter Outlet Pressure	psig	2.8
Sodium Hypo Pump Settings	spm	15
	% stroke	100
Coagulant Tank Level	gal	3
Coagulant Pump Settings	ml/min	5
CO2 Cylinder Pressure	psi	90
H2 Cylinder Pressure	psi	88
N2 Pressure	psi	132
N2 Flow Rate	scfm	-
Turbidity (Instrument)	NTU	0.09
Turbidity (OIT)	NTU	0.87

Collect while sump is running		
Sump Pump dischrq	psi	
Bag Filter ΔP	psi	
GAC Influent	psig	
GAC Effluent	psig	
IX-1 Pressure	psig	
Feed Tank Additions		
	H3PO4	Sodium Hypo
Time		
Initial Tank Level (gal)		
Stock Added		
Type of Water Used For Dilution		
Volume Dilution Added (gal)		
Total Volume Added (gal)		
Final Tank Level (gal)		

Note: There are 3785 mL per gallon.

Backwash start time:		
Backwash duration	min	
Initial Product Tank Level	gal	
Final Product Tank Level	gal	
Time of sample collection:		
Location	(NTU)	TSS Collected?
Lead Purge 1		<input type="checkbox"/> Yes <input type="checkbox"/> No
Lead Purge 2		<input type="checkbox"/> Yes <input type="checkbox"/> No
Lag Purge 1		<input type="checkbox"/> Yes <input type="checkbox"/> No
Lag Purge 2		<input type="checkbox"/> Yes <input type="checkbox"/> No
Media Filter		<input type="checkbox"/> Yes <input type="checkbox"/> No

NOTES:
 APT ALERTED US THEY FORGOT TO RESTART FILTER AID PUMP - RESTARTED PUMP UPON SITE ARRIVAL. THE TURBIDITY ON THE INSTRUMENT (POST FILTER AID ADDITION) WAS READING 0.46 NTU BUT SOON THEREAFTER DROPPED DOWN TO 0.09 UPON RESTARTING PUMP.

Type	Check
H3PO4 Stock (gal)	
Sodium Hypo Stock (gal)	
Additional Field Test Kits Needed?	Dissolved Oxyge
	Nitrate + Nitrite
	Nitrite
	Sulfide
	o-Phosphate
Calibration kits needed?	pH
	ORP
	Turbidity

8:30 AM

Date: 1/19/12

Time: 8 AM

Operator: BEROKOFF

Field Samples													
Calibration	pH calibration? <input type="checkbox"/> Yes <input type="checkbox"/> No Standards: <input type="checkbox"/> 4 <input type="checkbox"/> 7 <input type="checkbox"/> 10 Standard Reading: 4: _____ 7: _____ 10: _____			ORP calibration? <input type="checkbox"/> Yes <input type="checkbox"/> No Temp (Deg C): _____ Standard Reading: 220: _____			Turbidity calibration? <input type="checkbox"/> Yes <input type="checkbox"/> No Standards: <input type="checkbox"/> 0 <input type="checkbox"/> 20 <input type="checkbox"/> 200 <input type="checkbox"/> 1000 <input type="checkbox"/> 4000 Readings: 0.136: _____ 0.30: _____ 0.50: _____						
	Lead Sample <input type="checkbox"/> Lag Sample <input type="checkbox"/>			Lead Reactor: <input type="checkbox"/> MBfR1 <input checked="" type="checkbox"/> MBfR2 <input type="checkbox"/> SP-100A <input type="checkbox"/>			if MBfR1 in LEAD: SP-200B <input type="checkbox"/> if MBfR2 in LEAD: SP-100B <input type="checkbox"/>			Sample Collection Time: _____			
Sample Data	Parameter	Units	Influent	*Lead Reactor	*Lag Reactor	Aeration	Media Filter Effluent	Post Sodium Hypo	Finished Water	GAC 1 Effluent	GAC 2 Effluent	IX 1 Effluent	Permitted Outfall
	pH	(std units)											
	Temperature	(°C)											
	ORP	(mV)											
	Dissolved Oxygen	(mg/L)											
	Nitrate + Nitrite	(mg/L-N)											
	Nitrite	(mg/L-N)											
	Sulfide	(mg/L)											
	Turbidity	(NTU)							0.4				
	Chlorine Residual	(mg/L)											

* Signifies MBfR 1 or MBfR 2 depending on if reactor is in the lead or lag position - this changes every 96 hours

Note: shaded boxes are to remain blank

Post Finished Water System Inspection		
Collect while sump is running		
Sump Pump dischrg	psi	
Bag Filter ΔP	psi	2
GAC Influent	psig	12
GAC Effluent	psig	4.5
IX-1 Pressure	psig	1.1
Feed Tank Additions		
	H3PO4	Sodium Hypo
Time	1:45	1:45
Initial Tank Level (gal)	2.4	
Stock Added	-	
Type of Water Used For Dilution	-	
Volume Dilution Added (gal)	-	
Total Volume Added (gal)	-	
Final Tank Level (gal)	2.4	

Note: There are 3785 mL per gallon.

Backwash Record		
Backwash start time: _____		
Backwash duration	min	
Initial Product Tank Level	gal	
Final Product Tank Level	gal	
Time of sample collection:		
Location	(NTU)	TSS Collected?
Lead Purge 1		<input type="checkbox"/> Yes <input type="checkbox"/> No
Lead Purge 2		<input type="checkbox"/> Yes <input type="checkbox"/> No
Lag Purge 1		<input type="checkbox"/> Yes <input type="checkbox"/> No
Lag Purge 2		<input type="checkbox"/> Yes <input type="checkbox"/> No
Media Filter		<input type="checkbox"/> Yes <input type="checkbox"/> No

NOTES:
CHALLENGE TEST #3. SPILL OCCURRED FROM ONE OF THE EQUALIZATION TUBE LINES (IN-LINE W/PH PROBES) THAT CAME LOOSE FROM ITS FASTENED POSITION ATOP THE REACTORS AND SPILLED OUTSIDE THE CONTAINMENT AREA. CIM SMITH TOOK A

Treatment System Inspection		
Outlet Totalizer	gal	7535700
Target Flow Rate	gpm	6
Internal Recycle Rate	gpm	150/90
MBfR 1 pH	std units	7.2
MBfR 2 pH	std units	7.2
MBfR 1 ORP	mV	-563
MBfR 2 ORP	mV	-189
Nitrate Frequency	Hz	-
Last N Feed	ppm (N)	8.35
Last N R1	ppm (N)	0.06
Last N R2	ppm (N)	3.33
MBfR1 Sparge Rate	mm	240
MBfR2 Sparge Rate	mm	240
Phosphate Pump Settings	spm	20
	% stroke	30
Phosphate Concentration at Strainer	mg/LPO4	2.0
Aeration Tank Air Flow	scfm	3.2
Air Tank Pressure	psig	2.1
Target Media Filter Flow Rate	gpm	5
Media Filter Inlet Pressure	psig	6.4
Media Filter Outlet Pressure	psig	2.6
Sodium Hypo Pump Settings	spm	15
	% stroke	100
Coagulant Tank Level	gal	2
Coagulant Pump Settings	ml/min	5
CO2 Cylinder Pressure	psi	90
H2 Cylinder Pressure	psi	90
N2 Pressure	psi	138
N2 Flow Rate	scfm	-
Turbidity (Instrument)	NTU	0.23
Turbidity (OIT)	NTU	0.46

12:45 PM

Air Monitoring					
Zero Calibration? <input type="checkbox"/> Yes <input type="checkbox"/> No	Mixed Cylinder	Aeration Tank	MBIR 1	MBIR 2	OIT Area
Time					
Carbon Monoxide (ppm)					
Oxygen (%)					
Methane (% LEL)					
Hydrogen Sulfide (ppm)					

TIME	LEAD	LAG
9:57 AM	0.05 1.4	1.40 0.05
10:57 AM	3.48	0.05
11:57 AM	3.46	0.10
12:57 PM	3.36	0.10
1:57 PM	3.33	0.05
2:57 PM	2.82	0.06
3:57 PM	2.84	0.01
4:57 PM	-	-
5:57 PM	2.82	0.00
6:57 PM	2.90	0.00

NOTES CONT.:

~~PERCHLORATE~~ SAMPLE FROM BOTH THE SOIL AND THE PUDDLED WATER ON THE GROUND AND WILL SUBMIT IT FOR 24 TAT FOR PERCHLORATE. DAILY SPARGE SEQUENCE BEGAN @ 2pm - HOWEVER APT CAUGHT IT IN TIME BEFORE IT SPARGED. THE LAG REACTOR DID DRAIN DOWN WHICH WAS THE ONLY SNAG. APT RESTARTED NORMAL OPERATION AND FILLED REACTORS BACK UP. THIS ALL OCCURRED JUST AFTER TAKING THE 1:57 PM SAMPLE.

DUPLICATES MATRIX

DUPLICATE #	SAMPLE #	TIME
4	3-1	9:57
3	3-2	10:57
2	3-3	11:57
1	3-4	12:57
10	3-5	1:57
9	3-6	2:57
8	3-7	3:57
7	3-8	4:57
6	3-9	5:57
5	3-10	6:57

Date: 1/20/12

Time: 12:30 PM

Operator: BEROKOFF

Field Samples													
Calibration	pH calibration? <input type="checkbox"/> Yes <input type="checkbox"/> No Standards: <input type="checkbox"/> 4 <input type="checkbox"/> 7 <input type="checkbox"/> 10 Standard Reading: 4: _____ 7: _____ 10: _____			ORP calibration? <input type="checkbox"/> Yes <input type="checkbox"/> No Temp (Deg C): _____ Standard Reading: 220: _____			Turbidity calibration? <input type="checkbox"/> Yes <input type="checkbox"/> No Standards: <input type="checkbox"/> 0 <input type="checkbox"/> 20 <input type="checkbox"/> 200 <input type="checkbox"/> 1000 <input type="checkbox"/> 4000 Readings: 0.136: _____ 0.30: _____ 0.50: _____						
	Lead Sample <input type="checkbox"/> Lag Sample <input type="checkbox"/>			Lead Reactor: <input type="checkbox"/> MfBR1 <input type="checkbox"/> MfBR2 <input type="checkbox"/> SP-100A <input type="checkbox"/>			if MBfR1 in LEAD: SP-200B <input type="checkbox"/>			if MBfR2 in LEAD: SP-100B <input type="checkbox"/>			Sample Collection Time: _____
Sample Data	Parameter	Units	Influent	*Lead Reactor	*Lag Reactor	Aeration	Media Filter Effluent	Post Sodium Hypo	Finished Water	GAC 1 Effluent	GAC 2 Effluent	IX 1 Effluent	Permitted Outfall
	pH	(std units)											
	Temperature	(°C)											
	ORP	(mV)											
	Dissolved Oxygen	(mg/L)											
	Nitrate + Nitrite	(mg/L-N)											
	Nitrite	(mg/L-N)											
	Sulfide	(mg/L)											
	Turbidity	(NTU)											
	Chlorine Residual	(mg/L)							0.7				

* Signifies MBfR 1 or MBfR 2 depending on if reactor is in the lead or lag position - this changes every 96 hours

Note: shaded boxes are to remain blank

Treatment System Inspection		
Outlet Totalizer	gal	75456 ⁰⁰
Target Flow Rate	gpm	6
Internal Recycle Rate	gpm	150/90
MBfR 1 pH	std units	7.2
MBfR 2 pH	std units	7.2
MBfR 1 ORP	mV	-455
MBfR 2 ORP	mV	-230
Nitrate Frequency	Hz	-
Last N Feed	ppm (N)	8.36
Last N R1	ppm (N)	0
Last N R2	ppm (N)	2.76
MBfR1 Sparge Rate	mm	240
MBfR2 Sparge Rate	mm	240
Phosphate Pump Settings	spm	30
	% stroke	30
Phosphate Concentration at Strainer	mg/LPO4	1.8
Aeration Tank Air Flow	scfm	3.1
Air Tank Pressure	psig	2.0
Target Media Filter Flow Rate	gpm	5
Media Filter Inlet Pressure	psig	4.5
Media Filter Outlet Pressure	psig	2.8
Sodium Hypo Pump Settings	spm	15
	% stroke	100
Coagulant Tank Level	gal	0
Coagulant Pump Settings	ml/min	5
CO2 Cylinder Pressure	psi	90
H2 Cylinder Pressure	psi	90
N2 Pressure	psi	133
N2 Flow Rate	scfm	-
Turbidity (Instrument)	NTU	-
Turbidity (OIT)	NTU	0.63

Post Finished Water System Inspection		
Collect while sump is running		
Sump Pump dischrg	psi	
Bag Filter ΔP	psi	
GAC Influent	psig	
GAC Effluent	psig	
IX-1 Pressure	psig	
Feed Tank Additions		
	H3PO4	Sodium Hypo
Time	1:00	1:00
Initial Tank Level (gal)	1.7	15
Stock Added	100	-
Type of Water Used For Dilution	INF	-
Volume Dilution Added (gal)	3.3	-
Total Volume Added (gal)	3.3	-
Final Tank Level (gal)	5	15

Note: There are 3785 mL per gallon.

Backwash Record		
Backwash start time: _____		
Backwash duration	min	
Initial Product Tank Level	gal	
Final Product Tank Level	gal	
Time of sample collection: _____		
Location	(NTU)	TSS Collected?
Lead Purge 1		<input type="checkbox"/> Yes <input type="checkbox"/> No
Lead Purge 2		<input type="checkbox"/> Yes <input type="checkbox"/> No
Lag Purge 1		<input type="checkbox"/> Yes <input type="checkbox"/> No
Lag Purge 2		<input type="checkbox"/> Yes <input type="checkbox"/> No
Media Filter		<input type="checkbox"/> Yes <input type="checkbox"/> No

NOTES:

FILTER AID ~~WAS~~ TANK WAS EMPTY UPON ARRIVAL SO I TURNED OFF DOSING PUMP.

Inventory	
Type	Check
H3PO4 Stock (gal)	
Sodium Hypo Stock (gal)	
Additional Field Test Kits Needed?	Dissolved Oxyge
	Nitrate + Nitrite
	Nitrite
	Sulfide
	Chlorine
Calibration kits needed?	o-Phosphate
	pH
	ORP
	Turbidity

Date: 1/23/12

Time: 9:00

Operator: ARUCAN

Calibration		Field Samples											
pH calibration? <input checked="" type="checkbox"/> Yes <input checked="" type="checkbox"/> No		ORP calibration? <input checked="" type="checkbox"/> Yes <input checked="" type="checkbox"/> No				Turbidity calibration? <input checked="" type="checkbox"/> Yes <input checked="" type="checkbox"/> No							
Standards: <input type="checkbox"/> 4 <input type="checkbox"/> 7 <input type="checkbox"/> 10		Temp (Deg C):				Standards: <input type="checkbox"/> 0 <input type="checkbox"/> 20 <input type="checkbox"/> 200 <input type="checkbox"/> 1000 <input type="checkbox"/> 4000							
Standard Reading:		Standard Reading: 220:				Readings:							
4: 7: 10:						0.136: 0.30: 0.50:							
Lead Reactor: <input type="checkbox"/> MfBR1 <input type="checkbox"/> MfBR2		Lead Sample <input type="checkbox"/> SP-100A <input type="checkbox"/>		Lag Sample <input type="checkbox"/>		if MfBR1 in LEAD: SP-200B <input type="checkbox"/>		if MfBR2 in LEAD: SP-100B <input type="checkbox"/>		Sample Collection Time: <u>9:00</u>			
Parameter	Units	Influent	*Lead Reactor	*Lag Reactor	Aeration	Media Filter Effluent	Post Sodium Hypo	Finished Water	GAC 1 Effluent	GAC 2 Effluent	IX 1 Effluent	Permitted Outfall	
pH	(std units)											7.58	
Temperature	(°C)											19.5	
ORP	(mV)												
Dissolved Oxygen	(mg/L)												
Nitrate + Nitrite	(mg/L-N)												
Nitrite	(mg/L-N)												
Sulfide	(mg/L)												
Turbidity	(NTU)												
Chlorine Residual	(mg/L)												

* Signifies MfBR 1 or MfBR 2 depending on if reactor is in the lead or lag position - this changes every 96 hours

Note: shaded boxes are to remain blank

Post Finished Water System Inspection		
Collect while sump is running		
Sump Pump dischrg	psi	
Bag Filter ΔP	psi	
GAC Influent	psig	
GAC Effluent	psig	
IX-1 Pressure	psig	
Feed Tank Additions		
	H3PO4	Sodium Hypo
Time		
Initial Tank Level (gal)		
Stock Added		
Type of Water Used For Dilution		
Volume Dilution Added (gal)		
Total Volume Added (gal)		
Final Tank Level (gal)		

Note: There are 3785 mL per gallon.

Backwash Record		
Backwash start time:		
Backwash duration	min	
Initial Product Tank Level	gal	
Final Product Tank Level	gal	
Time of sample collection:		
Location	(NTU)	TSS Collected?
Lead Purge 1		<input type="checkbox"/> Yes <input type="checkbox"/> No
Lead Purge 2		<input type="checkbox"/> Yes <input type="checkbox"/> No
Lag Purge 1		<input type="checkbox"/> Yes <input type="checkbox"/> No
Lag Purge 2		<input type="checkbox"/> Yes <input type="checkbox"/> No
Media Filter		<input type="checkbox"/> Yes <input type="checkbox"/> No

NOTES:
 Duplicate 1 = outfall
 Dup 2 = influent
 System was turned off @ 9:45

Treatment System Inspection		
Outlet Totalizer	gal	
Target Flow Rate	gpm	
Internal Recycle Rate	gpm	
MBfR 1 pH	std units	
MBfR 2 pH	std units	
MBfR 1 ORP	mV	
MBfR 2 ORP	mV	
Nitrate Frequency	Hz	
Last N Feed	ppm (N)	
Last N R1	ppm (N)	
Last N R2	ppm (N)	
MBfR1 Sparge Rate	mm	
MBfR2 Sparge Rate	mm	
Phosphate Pump Settings	spm % stroke	
Phosphate Concentration at Strainer	mg/LPO4	
Aeration Tank Air Flow	scfm	
Air Tank Pressure	psig	
Target Media Filter Flow Rate	gpm	
Media Filter Inlet Pressure	psig	
Media Filter Outlet Pressure	psig	
Sodium Hypo Pump Settings	spm % stroke	
Coagulant Tank Level	gal	
Coagulant Pump Settings	ml/min	
CO2 Cylinder Pressure	psi	
H2 Cylinder Pressure	psi	
N2 Pressure	psi	
N2 Flow Rate	scfm	
Turbidity (Instrument)	NTU	
Turbidity (OIT)	NTU	

Date: 01/24/12

Time: 9:30

Operator: ARUCAN

Field Samples													
Calibration	pH calibration? <input checked="" type="checkbox"/> Yes <input type="checkbox"/> No Standards: <input type="checkbox"/> 4 <input type="checkbox"/> 7 <input type="checkbox"/> 10 Standard Reading: 4: _____ 7: _____ 10: _____			ORP calibration? <input type="checkbox"/> Yes <input checked="" type="checkbox"/> No Temp (Deg C): _____ Standard Reading: 220: _____			Turbidity calibration? <input type="checkbox"/> Yes <input checked="" type="checkbox"/> No Standards: <input type="checkbox"/> 0 <input type="checkbox"/> 20 <input type="checkbox"/> 200 <input type="checkbox"/> 1000 <input type="checkbox"/> 4000 Readings: 0.136: _____ 0.30: _____ 0.50: _____						
	Lead Reactor: <input checked="" type="checkbox"/> MBfR1 <input type="checkbox"/> MBfR2 Lead Sample <u>SP-100A</u> Lag Sample _____ if MBfR1 in LEAD: SP-200B <input checked="" type="checkbox"/> if MBfR2 in LEAD: SP-100B <input type="checkbox"/>			Sample Collection Time: _____									
Sample Data	Parameter	Units	Influent	*Lead Reactor	*Lag Reactor	Aeration	Media Filter Effluent	Post Sodium Hypo	Finished Water	GAC 1 Effluent	GAC 2 Effluent	IX 1 Effluent	Permitted Outfall
	pH	(std units)											7.64
	Temperature	(°C)											19.5
	ORP	(mV)											
	Dissolved Oxygen	(mg/L)											
	Nitrate + Nitrite	(mg/L-N)											
	Nitrite	(mg/L-N)											
	Sulfide	(mg/L)											
	Turbidity	(NTU)											
	Chlorine Residual	(mg/L)							0.5	0			

* Signifies MBfR 1 or MBfR 2 depending on if reactor is in the lead or lag position - this changes every 96 hours

Note: shaded boxes are to remain blank

Treatment System Inspection		
Outlet Totalizer	gal	
Target Flow Rate	gpm	
Internal Recycle Rate	gpm	
MBfR 1 pH	std units	
MBfR 2 pH	std units	
MBfR 1 ORP	mV	
MBfR 2 ORP	mV	
Nitrate Frequency	Hz	
Last N Feed	ppm (N)	
Last N R1	ppm (N)	
Last N R2	ppm (N)	
MBfR1 Sparge Rate	mm	
MBfR2 Sparge Rate	mm	
Phosphate Pump Settings	spm	
Phosphate Concentration at Strainer	% stroke	
Aeration Tank Air Flow	mg/LPO4	
Air Tank Pressure	scfm	
Target Media Filter Flow Rate	psig	
Media Filter Inlet Pressure	gpm	
Media Filter Outlet Pressure	psig	
Sodium Hypo Pump Settings	spm	
Coagulant Tank Level	% stroke	
Coagulant Pump Settings	gal	
CO2 Cylinder Pressure	ml/min	
H2 Cylinder Pressure	psi	
N2 Pressure	psi	
N2 Flow Rate	scfm	
Turbidity (Instrument)	NTU	
Turbidity (OIT)	NTU	

Post Finished Water System Inspection		
Collect while sump is running		
Sump Pump dischrg	psi	
Bag Filter ΔP	psi	
GAC Influent	psig	
GAC Effluent	psig	
IX-1 Pressure	psig	
Feed Tank Additions		
	H3PO4	Sodium Hypo
Time		
Initial Tank Level (gal)		
Stock Added		
Type of Water Used For Dilution		
Volume Dilution Added (gal)		
Total Volume Added (gal)		
Final Tank Level (gal)		

Note: There are 3785 mL per gallon.

Backwash Record		
Backwash start time: _____		
Backwash duration	min	
Initial Product Tank Level	gal	
Final Product Tank Level	gal	
Time of sample collection:		
Location	(NTU)	TSS Collected?
Lead Purge 1		<input type="checkbox"/> Yes <input type="checkbox"/> No
Lead Purge 2		<input type="checkbox"/> Yes <input type="checkbox"/> No
Lag Purge 1		<input type="checkbox"/> Yes <input type="checkbox"/> No
Lag Purge 2		<input type="checkbox"/> Yes <input type="checkbox"/> No
Media Filter		<input type="checkbox"/> Yes <input type="checkbox"/> No

NOTES:
 SYSTEM RE-STARTED @ 9:45. ON START-UP, VERY STRONG SMELL OF SULFUR/SULFIDE

Inventory	
Type	Check
H3PO4 Stock (gal)	
Sodium Hypo Stock (gal)	
Additional Field Test Kits Needed?	Dissolved Oxyge
	Nitrate + Nitrite
	Nitrite
	Sulfide
	Chlorine
Calibration kits needed?	o-Phosphate
	pH
	ORP
	Turbidity

ESTCP: Technology Demonstration Plan
 Perchlorate Destruction Using Membrane Biofilm Reduction
 ESTCP Project Number ER-200541

Air Monitoring					
Zero Calibration? <input type="checkbox"/> Yes <input type="checkbox"/> No	Mixed Cylinder	Aeration Tank	MBFR 1	MBFR 2	OIT Area
Time					
Carbon Monoxide (ppm)					
Oxygen (%)					
Methane (% LEL)					
Hydrogen Sulfide (ppm)					

NOTES CONT.:			TIME 1	NITRATE		
DUPPLICATE	TIME	LOCATION	FEED	LEAD	LAG	
			9:45	8.32	8:12	6:28
1	11:45	FINISH	10:00	8.32	5.30	0.50
2	1:45	FINISH	10:15	8.30	5.24	4.68
3	2:45	FINISH	10:45	8.30	5.28	2.69
4	5:45	FINISH	11:45	8.32	1.77	—
			12:45	8.32	1.89	0.55
			1:45	8.32	1.91	0.29
			2:45	8.32	1.59	0.06
			3:45			
			4:45			
			5:45			

Date: 1/25/12

Time: 9:15

ESTCP: Technology Demonstration Plan
 Perchlorate Destruction Using Membrane Biofilm Reduction
 ESTCP Project Number ER-200541
 Operator: ARUCAN

pH calibration? <input checked="" type="checkbox"/> Yes <input type="checkbox"/> No Standards: <input checked="" type="checkbox"/> 4 <input checked="" type="checkbox"/> 7 <input type="checkbox"/> 10 Standard Reading: 4: <u>4.08</u> 7: <u>7.03</u> 10: <u>9.0</u> <u>10.12</u>		ORP calibration? <input type="checkbox"/> Yes <input checked="" type="checkbox"/> No Temp (Deg C): _____ Standard Reading: 220: _____		Turbidity calibration? <input type="checkbox"/> Yes <input checked="" type="checkbox"/> No Standards: <input type="checkbox"/> 0 <input type="checkbox"/> 20 <input type="checkbox"/> 200 <input type="checkbox"/> 1000 <input type="checkbox"/> 4000 Readings: 0.136: _____ 0.30: _____ 0.50: _____								
Lead Reactor: <input checked="" type="checkbox"/> MBfR1 <input type="checkbox"/> SP-100A if MBfR1 in LEAD: SP-200B <input checked="" type="checkbox"/> if MBfR2 in LEAD: <u>SP-200B</u>		Sample Collection Time: <u>9:15</u>										
Parameter	Units	Influent	*Lead Reactor	*Lag Reactor	Aeration	Media Filter Effluent	Post Sodium Hypo	Finished Water	GAC 1 Effluent	GAC 2 Effluent	IX 1 Effluent	Permitted Outfall
pH	(std units)											
Temperature	(°C)											7.69
ORP	(mV)											19.1
Dissolved Oxygen	(mg/L)											
Nitrate + Nitrite	(mg/L-N)											
Nitrite	(mg/L-N)											
Sulfide	(mg/L)											
Turbidity	(NTU)											
Chlorine Residual	(mg/L)											

Outlet Totalizer	gal	757940
Target Flow Rate	gpm	6
Internal Recycle Rate	gpm	150/90
MBfR 1 pH	std units	7.1
MBfR 2 pH	std units	7.2
MBfR 1 ORP	mV	-201
MBfR 2 ORP	mV	-483
Nitrate Frequency	Hz	
Last N Feed	ppm (N)	8.39
Last N R1	ppm (N)	0.24
Last N R2	ppm (N)	0.45
MBfR1 Sparge Rate	mm	240
MBfR2 Sparge Rate	mm	240
Phosphate Pump Settings	spm	20
Phosphate Concentration at Strainer	mg/LPO4	3.0
Aeration Tank Air Flow	scfm	3.2
Air Tank Pressure	psig	2.0
Target Media Filter Flow Rate	gpm	4
Media Filter Inlet Pressure	psig	1.6
Media Filter Outlet Pressure	psig	2.3
Sodium Hypo Pump Settings	spm	15
	% stroke	100
Coagulant Tank Level	gal	
Coagulant Pump Settings	ml/min	
CO2 Cylinder Pressure	psi	91
H2 Cylinder Pressure	psi	90
N2 Pressure	psi	132
N2 Flow Rate	scfm	
Turbidity (Instrument)	NTU	
Turbidity (OIT)	NTU	

Collect while sump is running		
Sump Pump dischrg	psi	
Bag Filter ΔP	psi	
GAC Influent	psig	
GAC Effluent	psig	
IX-1 Pressure	psig	
Feed Tank Additions		
	H3PO4	Sodium Hypo
Time		
Initial Tank Level (gal)		
Stock Added		
Type of Water Used For Dilution		
Volume Dilution Added (gal)		
Total Volume Added (gal)		
Final Tank Level (gal)		

Backwash start time: _____		
Backwash duration	min	
Initial Product Tank Level	gal	
Final Product Tank Level	gal	
Time of sample collection: _____		
Location	(NTU)	TSS Collected?
Lead Purge 1		<input type="checkbox"/> Yes <input type="checkbox"/> No
Lead Purge 2		<input type="checkbox"/> Yes <input type="checkbox"/> No
Lag Purge 1		<input type="checkbox"/> Yes <input type="checkbox"/> No
Lag Purge 2		<input type="checkbox"/> Yes <input type="checkbox"/> No
Media Filter		<input type="checkbox"/> Yes <input type="checkbox"/> No

Type	Check
H3PO4 Stock (gal)	
Sodium Hypo Stock (gal)	
Additional Field Test Kits Needed?	Dissolved Oxygen
	Nitrate + Nitrite
	Nitrite
	Sulfide
	Chlorine
Calibration kits needed?	o-Phosphate
	pH
	ORP
	Turbidity

NOTES:
 SPARGE TOOK PLACE @ 9:30. SAMPLES WERE TAKEN @ 9:15. APT TO FLUSH SYSTEM @ 10:00. ACTIVITIES WILL INCLUDE BACKWASHING BOTH MEDIA FILTERS AND SHUT DOWN OF
 ? - TAKEN AFTER SPARGE PROCESS

Note: There are 3785 mL per gallon.

Air Monitoring

Zero Calibration? <input type="checkbox"/> Yes <input type="checkbox"/> No	Mixed Cylinder	Aeration Tank	MBFR 1	MBFR 2	OIT Area
Time					
Carbon Monoxide (ppm)					
Oxygen (%)					
Methane (% LEL)					
Hydrogen Sulfide (ppm)					

NOTES CONT.:

GASSES. SWAGELOCK VALVES AT THE ~~SOX~~ GAS CONTROLLER BOX WERE SHUT CLOSED
 TO ISOLATE FROM SYSTEM. GAS CYLINDERS WERE ~~BEING~~ DISCONNECTED AND
 READY FOR PICK-UP ON 1/26/12. THE SYSTEM FLOW RATE WAS RAISED TO
 20 GPM. THE SUMP ~~BOX~~ TANK HAD FILLED AND TRIGGERED A HIGH LEVEL
 ALARM. THE ~~SYSTEM~~ SUMP PUMP WAS NOT ABLE TO KEEP UP W/ 20 GPM.
 THE SYSTEM FLOW RATE WAS CHANGED TO 10 GPM. THE MBFR SYSTEM WAS
 SHUT OFF AT 5:00 PM.

APPENDIX C
FIELD NOTES AND MONITORING DATA

- Field Notes
- Monitoring System Measurements
- Field Sample Analytical Results

FIELD NOTES

Date	Day	Operator	Lead Reactor	Notes
4/20/11			-	Yesterday (4/20/11) APT & CDM worked on getting MBfR & associated system hydraulics up and running.
4/21/11			-	At end of day, the aeration tank & product tank were dosed with ~65ppm of chlorine (1.42gal of 6.15% concentration in 1300gal). At 9am (4/21/11), took Cl2 residuals on both aeration and product tanks and both recorded levels over 5 mg/L. Calibrated pH/ORP meters and turbidimeter. Did not take lab samples today as the GAC disposorb units were not operating properly - the pressure was building up in the vessel to the point where it was restricting flow. APT left MBfR on recirculation so it can begin to inoculate. Added 1 ppm H3PO4 to each reactor. Working toward getting new GAC unit in system in order to solve pressure build-up issue.
4/22/11			-	MBfR had no issues operating over night in recirculation mode. pH meter check: dipped into buffer 4 solution, read 4.01. Buffer 7 solution, read 7.00. Buffer 10 solution read 219mV against standard solution. Calibrated APT's pH meters for both MBfR 1 & MBfR 2.
4/25/11			-	Water level in MBfR 1 decreased by roughly 10% over the weekend. Also noticed that 4 modules were turned off on MBfR 2. Spoke to Ryan (APT) who knew about this and then had me turn them back on around 11:20 am. Took daily reading prior to turning on the 4 reactors that were previously off.
4/27/11			-	Carbon Supply Inc (CSI) came to site and switched out carbon media from Calgon disposorbs to their steel vessels.
4/28/11	0			Official startup date
4/29/11	1		MBfR 2	System ran overnight without any mishaps. Took monthly/annual grab samples today. After taking all grab samples for lab, APT shut off H2 feed to system for ~1.5 hours in order to calibrate LEL sensors - meaning today's analytical field tests may not be accurate. Was unable to perform field tests on multimedia filter due to APT running backwashes on both MBfR & Filter.
5/2/11	4		MBfR 1	System appears to be stable over it's first weekend in operation (no major issues/leaks). pH meter read 4.02, 7.01, 10.11 against buffer solutions. ORP read 218mV against standard solution.
5/4/11	6		MBfR 2	pH meter was tested against buffer solutions, readings were 4.02, 7.02 & 10.07 respectively. ORP meter was tested against buffer solutions with reading of 217. APT informed CDM that MBfR feed pump was malfunctioning and was shut down due to air in the system. APT had also told CDM that NO2 & NO3 readings may be misleading. Turbidity meter was calibrated using solutions. APT worked towards filling Hypochlorite tank and determined pump flow rate based on concentration. Topped of Phosphate tank; added 3.8 gallons of water and 42.3 ml of 85% H3PO4

Date	Day	Operator	Lead Reactor	Notes
5/6/11	8		MBfR 2	Aeration tank has slight smell of Sulfur. MBfR feed pump = 1 gpm due to problems with air in the system. APT had informed CDM that the feed pump had lost its prime and was set at a lower flow-rate. To alleviate the problem, CDM raised 18" the low level switch in the feed tank. After raising it, the flow on the feed pump was increased to 10 gpm. Nitrate laboratory sample was taken from the effluent of the Nitrate analyzer. The hertz reading was also recorded to help calibrate the Nitrate sensor. Laboratory samples were taken at 12:00, and test America picked up at 1:00. One sample, Aeration XX was not picked up by the courier. CDM replaced the air release valve on GAC vessel 2.
5/9/11	11		MBfR 1	Topped off phosphate tank: added 48.2ml H3PO4 & 3.6 gal water.
5/11/11	13		MBfR 2	David informed CDM that feed pump had malfunctioned last night and readings from the MBfR 1&2 reactors will have to be postponed because they will not be representative. The pump will require some troubleshooting in order for it to run properly. Laboratory samples we postponed to 12:00 on the MBfR reactors. The MBfR samples were taken from the nitrate effluent line at the top of the reactors. Samples for Perchlorate and Nitrate from the MBfR 1&2 were sent to the lab with a 24 hour TAT. Clyde had tried to trouble shoot pump problem. An air leak may be present which causes the loss of prime at higher flow rates. Clyde had taken apart the feed pump piping. No damage or missing parts were observed. Clyde reinstalled the feed piping using new Teflon on the pipe fittings and realigning the pump so that the pipe experiences no "springing" force. Feed flow increased from 5 to 8gpm at 17:50. R2 H2 P increased from 6 to 8psig at 20:05.
5/13/11	15		MBfR 2	APT was on site yesterday fixing prime problem in feed pump. Pipe shavings were found lodged into the impellor. APT increased feed rate to 8 gpm. APT installed new sample location taps for SP-100 & SP-200 to mitigate high D.O. level readings for field analysis kits. Inspected feed tank for any additional pipe shavings but nothing was visible. APT set up chlorine dose pump to begin feeding media filter yesterday. Measured flow rate on C12 pump; pump set @ 131 spm & 25% stroke length. This yielded 30 ml in 14 minutes (or 2.1 ml/min - 12.5% Sodium Hypochlorite). Added 3.7 gallons of water * 36 ml H3PO4 to phosphate tank. R2 H2 P increased from 8 to 14psig during the day. CO2 lumen ratio for reactors changed from 0.05 to 0.15 at 23:00.
5/14/11	16	NA	NA	pH set points changed from 7.5 to 7.2 at 16:30. Feed flow changed from 8 to 10 gpm at 17:15. Filter from changed from 5 gpm to 8 gpm 22:45.
5/16/11	18		MBfR 1	APT increased target flow rate from 8 gpm to 10 gpm on 5/15/11. Checked pH probe against buffer solutions and got the following: 4.00, 7.05, 10.14. Checked ORP probe against buffer, read 218 mV.

Date	Day	Operator	Lead Reactor	Notes
5/18/11	20		MBfR 1	Topped off phosphate tank: added 37.5 ml H3PO4 & 2.8 gal water. APT had me measure the fiber purge rate on each reactor then drain each purge line of any moisture. R1 bubbled at 2 bubbles per second & R2 at ~8 bubbles per second. R1 did not discharge any moisture & R2 discharged ~0.5 ml of moisture (these fibers were drained at 12:40pm). At 1:40pm APT had me increase purge rate on R1 to equal that of R2 as best as possible. Both purging @ ~8 bubbles/second. Fiber drains venting test around 12:00pm.
5/19/11	21	NA	NA	At 11:30am, R2 CO2 lumen flow ratio was changed from 0.15 to 0.05 and R2 H2 Pressure was adjusted (from 14 psig to 11.5 psig) accordingly to keep the same R2 H2 flow as before. This was done in order to determine the effect of CO2 lumen flow on nitrate reduction. R2 H2 P was increased to 15 psig at 16:10. R1 H2 P was increased from 6 to 8 psig at 22:46. R2 H2 P was increased to 18 psig at 22:50.
5/20/11	22	CA	MBfR 2	All influent readings//samples were taken after the nutrient injection point at the skid system. Phosphate tank was emptied and filled with new solution. The new Phosphate solution contains .52 mg/L-P. APT onsite. APT has shut down the system between 10:00 -11:300 to calibrate the pH and ORP meter on reactors 1 and 2. Test America onsite to pick up samples. APT restarts the system and has to manually turn on the Hydrogen generator. At 7:40am, pH set points for R1 and R2 increased to 7.5. At 10:00 am, system was shut down by Richard (Temp-R1 and R2 ORP fixed). At 12:20 system started again. At 18:45 Hydrogen leak detected in H2 generator (E-13 error), unable to restart H2 generator. System running with H2 cylinders.
5/21/11	23	NA	NA	Feed flow decreased from 10 to 8 gpm and R2 H2 P from 18 to 12 psig at 11:00. R1 H2 P decreased from 8 to 6 psig at 17:05 (we want some operating conditions as before to replicate previous results). pH set points changed from 7.5 to 7.2 at 17:13 because we don't want to precipitate hardness in modules.
5/23/11	25	DB	MBfR 1	When phosphate tank was filled last time out, the valve leading to the dosing pump was not opened back up so no phosphate was being dosed to system. MBfR flow rate was lowered on 5/21/11 to 8 gpm (from 10 gpm) due to lack of nitrate removal (this may be due to no H2PO4). Increased stroke length on Cl2 pump to 40 and decreased stokes per minute to 80 (from 131), due to pump losing its prime upon each site visit - pump should be operating in mid to high range. H2 generator stopped working on 5/20/11. Only had 700 lbs remaining in backup 6-pack so that ran dry - however, APT verified that system was still being dosed with H2 Monday morning so it likely ran out around the time I arrived. Switched hose over to alternate 6-pack. New set of H2 cylinders connected at 10:40. Filter flow changed to 7.5 gpm at 14:30.

Date	Day	Operator	Lead Reactor	Notes
5/25/11	27	CA	MBfR1	Richard with APT is onsite to repair and clean the Nitrate analyzer located in the reactor skid. He has removed all tubing, but the system is still operational. No Nitrate analyzer readings were taken today at the HMI. Dave Musico and Jonathan Roberts with NALCO visit the site. They NALCO representatives will investigate alternate applications that can be installed at the site to reduce turbidity. The treatment process was reviewed and NALCO requested information regarding discharge limits and water quality data. Cole with CDM is onsite at the request of APT to pick up all of the debris onsite and do general house clean for tomorrow's site tour. Nitrate analyzer leaking this morning because the SS tubing coming out from the analyzer was plugged. System shut down for a while. New cell stack installed and H2 generator started at 15:00.
5/26/11	28	NA	NA	R1 H2 P increased from 6 to 7 psig at 9:53.
5/27/11	29	DB	MBfR2	Injection valve for phosphate line was closed upon site arrival. Immediately opened and reinstated chemical flow to MBfR. Ran flow test on phosphate dosing pump: 1) 480 ml = Time zero. 2) 460 ml = Time 10 minutes. Phosphate pump successfully flowing @ 2 ml/min. Phosphate addition restarted at 12:45 which caused the feed flow meter to fluctuate from 6.5 to 9.5 gpm therefore phosphate is being pumped to the top of lead reactor R2.
5/28/11	30	NA	NA	R2 H2 P increased from 12 to 14 psig and R2 CO2 lumen ratio from 0.05 to 0.10 at 16:49. R2 H2 P increased from 14 to 16psig at 18:44.
5/30/11	32	NA	NA	Rialto R2 water flow LO-LO alarm at 12:27.
5/31/11	33	NA	NA	Feed flow increased from 8 to 10 gpm at 12:33. R1 H2 P increased from 7 to 8 psig at 15:50.
6/1/11	34	DB	MBfR1	On 5/31/11, APT remotely increased feed to system from 8 gpm to 10 gpm. Took perchlorate samples prior to the increase and submitted to lab on 6/1/11. Checked pH probe against buffers - results were as follows: 4.00, 7.02 & 10.17. ORP probe read 218 mV against standard solution. On 5/31/11 the phosphate feed line was moved to the lead reactor (R1). Operator made sure that chemical was being fed into tank, however sometime over the night air built up at the high point which prevented any phosphate to be dosed to system. I immediately bled out air bubble and increased feed rate on pump from a 25 stroke length to 35 in order to over-compensate for the missed time, then turned it back down to 25 after a few hours. Over the span from 5/31 @ 12pm to 6/1 @ 8:30am, there was a total of 0.4 gal of H3PO4 solution added to system. Yesterday, operator added 2.5 gal of water and 200 ml 85% H3PO4. Today I did a test to see what concentration was in the Cl2 tank - did a 4000:1 dilution which yielded a 3.0 ppm reading, thus overall concentration in tank = 12,000ppm. Drained R1 & R2 fiber drains at 13:10. R1 H2 P increased from 8 to 10psig at 21:36 and R2 H2 P from 16 to 18 psig at 22:26.
6/2/11	35	NA	NA	Sparge cycle at 13:45.

Date	Day	Operator	Lead Reactor	Notes
6/3/11	36	CA	MBfR1	Cameron Welding onsite to check chemical gas supply. Richard with APT Water onsite to repair the chlorine dosing pump, install a pressure gauge on the nitrate analyzer feed. Richard has also tapped a new phosphate injection point downstream of the MBfR flow meter. Daniel is onsite working on troubleshooting the chlorine feed pump. Daniel has mixed a new chlorine solution with a 4:1 concentration. 4 gallons of 12.5% Cl ₂ and 8 gallons of water from the media filter effluent. Clyde has added 4 gallons of phosphate solution to the feed tank. The 4 gallon solution consisted of 320 mg of phosphoric acid and 4 gallons of water. The phosphate feed pump was reinstalled at the new injection point and flow was verified to be injected. Weekly as well as Monthly samples were taken and was picked up by Test America @ 12:30. Richard tapped in a new port for phosphate injection at 13:15. Sparge cycle at 15:48.
6/4/11	37	NA	NA	R2 modules flushed at 11:35. R1 modules flushed at 11:45 (50 gpm through each module for a couple of minutes). Feed flow increased from 10 to 12 gpm at 13:40.
6/5/11	38	NA	NA	R1 modules flushed.
6/6/11	39	CA	MBfR2	Clyde purged hydrogen in lines from MBfR 1 & 2 and measure expelled liquid per recommendation from APT. Clyde will also measure the purge rate on 1/8 tube. Phosphate pump lost its prime over the weekend. A flow test will be conducted on phosphate feed pump. APT instructed to open product tank feed valve to allow 11 gpm of flow, Clyde has switched bag filters on outfall system due to a 5 psi change in pressure reading. Clyde set the phosphate pump to 65 strength length @ 10% strokes. Chlorine pump set at 100 frequency to achieve 1 ppm chlorine, possibly due to nitrate demand. Adjusted the flow rate of the pump back to original setting because the chlorine storage tank did not have enough storage capacity to pump at that rate. Chlorine residual detected after this adjustment at the addition point was ND. Fiber venting for R1 & R2 at 9:00. Valve to the filter media was opened more (it was partially opened before) which allowed for a higher filter flow and a decrease in the inlet and outlet pressures. Filter flow increased from 7.5 to 11 gpm at 10:22.
6/7/11	40	NA	NA	Gap in the data due to power being out between 9:30 and 13:45.
6/8/11	41	NA	NA	Sparge cycle at 4 am. David worked on system later that day. He did the following: 1) He replaced the phosphate dosing pump. 2) He put in two new valves for polymer injection: one into media filter feed pump suction line and one after the media filter feed pump. 3) He also put in continuous module purge lines to each pump's suction and also a mechanism to measure that flow or to potentially take a sample.
6/9/11	42	NA	NA	R1 H ₂ P increased from 10 to 12psig at 20:20.

Date	Day	Operator	Lead Reactor	Notes
6/10/11	43	DB	MBfR1	Cameron welding filled N2 micro bulk. Began recording membrane purge rate today as APT installed a rotameter on 6/8/11. Nitrate analyzer went down around 9:15 am due to Daniel pressing the wrong key on the analyzer. Daniel reset the analyzers per request from APT; the reading was fixed at approximately 1:30 pm. Added 4 gallons of sodium hypochlorite (12.5% sodium hypo) and 8 gallons of media filter effluent. Set the pump at 100% stroke length and 40 gpm. Added 330 ml of 85% H3PO4 and 3.7 gallons of feed water to phosphate tank.
6/11/11	44	NA	NA	The N analyzer was thought to have failed at 15:28 so we closed the sample valves in response in case it may be leaking and no water was getting to the sensor. Sparge process initiated at 23:00
6/12/11	45	NA	NA	Sparge cycle at 4am.
6/13/11	46	DB	MBfR2	Phosphate dosing pump was leaking upon arrival. The leak caused by the discharge compression fitting connection on dosing pump not being tightened. Fitting was tightened to stop the leak. Nitrate analyzer was off upon arrival. Aeration compressor was off upon arrival. Over the weekend the GFI switched off causing nitrate analyzer and aeration compressor to shut off, as they are tied to the same receptacle. Reset GFI and both aeration/N2 analyzer came back on. Had to increase sodium hypochlorite pump to 140 spm from 40 spm to obtain a 2.5 ppm chlorine residual on post filtration. Sodium hypochlorite appears to be degrading.
6/13/11	46	NA	NA	The GFI receptacle that supplies power to the N Analyzer and Aeration Blower was reset at 10:10; this fixed the N Analyzer and Aeration blower problem. Sample valves were immediately set back in auto.
6/15/11	48	DB	MBfR2	Pat Evans and Jen Smith visited the site to go over system with Jen. Phosphate suction line accumulated air bubbles causing no phosphate being dosed to the system. Visually inspected tops of reactors and saw foam accumulation in the lag reactor which is a sign of biological activity. Also on R1 the center module was more brown in appearance compared to the outer modules. Took weekly permit samples on effluent. Calibrated phosphate pump, see notes for settings and flow rates achieved.
6/15/11	48	NA	NA	Calibration of turbidity meter in the afternoon around 4 pm. They were working with N Analyzer too.
6/16/11	49	DB	MBfR1	Checked pH meter against buffers, they read 4.02, 7.01, and 10.11. Noticed very small air bubbles coming through SP-100A tubing. This may be due air entrainment from water flowing from the lead reactor on its way to the lag reactor from the over the over-flow drain. JS checked turbidity standards, and measured 0.0, 20.6, and 104 NTU. DI water read 0.16 and <1 NTU standard read 0.20 when checked a second time. Collected a sample at 12:50 after the phosphate feed for o-phosphate analysis, sample was called Influent-Post Nutrient. Collected samples at 15:15 from the effluent of the lead (SP-100A) and lag (SP-200B) for perchlorate, nitrate, and nitrite analysis samples were called Lead Reactor and Lab Reactor. Also collected a second round of field data monitoring at SP-100A, SP-100B, and SP-200B. At 15:35 added 90 ml of H3PO4 and 1 gallon of feed water to the phosphate tank, final tank level was 5 gallons. Performed chlorine demand testing.
6/16/11	49	NA	NA	Sparge at 4 am. High Sump Level by accident at 12:45.

Date	Day	Operator	Lead Reactor	Notes
6/20/11	53	DB	MBfR2	Added 16 gal 12.5% sodium hypo and 14 gal filter effluent. Began dosing post media effluent at 12:30 pm, pump setting set to 100% stroke length and 50 gpm for an injection volume of ~10.6 ml/min. At 2:30pm measured residual on finished water, it read well over 5 ppm. Before leaving site I turned down metering pump to 100 % and 30 gpm for an injection volume of ~5.9 ml/min. APT had me conduct a nitrate analyzer test between 1:15 pm-2 pm all while shutting off feed. This was done prior to taking daily data. This caused us to not be able to take any further data. Took weekly samples for permit compliance. Covered sod. hypo tank w/ black bags. Covered online turbidimeter and R2 orp probe with black trash bags.
6/20/11	53	NA	NA	Sparge at 4 am. Rialto R2 water flow LO-LO alarm at 5:05. R2 restarted at 8:48am. N analyzer calibration
6/21/11	54	NA	NA	Scatter data because the N analyzer is taking more than 15 minutes (>35 min) to stabilize to a new number after stream switching from R1 to R2.
6/22/11	55	NA	NA	Ryan working on system during the day (check his email on 06/23/11 for more details). Data missing from 21:12 (06/22) to 14:11 (06/23).
6/23/11	56	NA	NA	OIT connection problem fixed at 14:11.
6/26/11	59	NA	NA	Sparge at 16:00.

Date	Day	Operator	Lead Reactor	Notes
6/27/11	60	CA	MBfR1	At 07:30 measured chlorine residual at the filter effluent as 7.5 ppm, chlorine residual for the product water was 6.0 ppm. Added 15 gallons of water from the filter effluent to the sodium hypo tank, no hypochlorite was added. Since the residual was so high, it was decided that the tank could be diluted further. Collected field samples at 08:00. pH and ORP probes were calibrated and tested against the standards. Shipment of hypochlorite was received at 09:45, contained 4 drums of 15 gallon containers. Nitrate and nitrite field samples were collected and run in parallel with nitrate and nitrite standards. Nitrate and nitrite standards were initially 10.0 mg/L and were diluted 1:5 using DI water to read in range of the nitrate+nitrite test kit. The concentration read for the diluted standard was 2 mg/L, the reading for the standard sample was therefore 10 mg/L. DI water read 0 mg/L. At 10:35 the Chemetrics phosphate test kit was received. The phosphate tank solution was diluted 1:10 three times. The 1:1,000, 1:10,000, and 1:100,000 was diluted again at 1:2. The expected phosphate concentrations for those dilutions were 35.8, 3.58, and 0.36 mg/L-PO4; the test kit readings were >10, 5, and 1.5 mg/L-PO4. Samples were also collected from the lead influent (after phosphate addition), lead effluent, and lag effluent. The readings were 3.5, 3.5, and 1.5 mg/L-PO4, which are equivalent to 1.14, 1.14, and 0.49 mg/L-P. A sample was collected from the lead influent at 12:00 and sent to Test America for analysis; the concentration was 1.2 mg/L. CDM contacted APT and learned that a higher concentration of Phosphate was added to the tank last Wednesday by Ryan. He added 900 ml in 5 gallons, for a final estimated concentration of 1.03 mg/L-P. During the conference call, it was decided to continue feeding the phosphate tank with a similar concentration of phosphate. Added 570 ml phosphate and 3 gallons to the tank. A leak is present between the GAC vessels, and only occurs when the sump is running. The leak was not observed the previous two times CDM was on site, but was observed on 6/15. Placed a bucket under the quick connect fitting where the leak is coming from. Only a small amount of water is leaking (drops at a time). APT informed CDM that the hydrogen generator was shut off on Thursday, Hydrogen cylinders need to be re-ordered. Clyde will order more when back in the office. Hach turbidity meter was calibrated using the amCO standards after measuring turbidity in samples.
6/27/11	60	NA	NA	Richard cleaned and removed the Nitrate analyzer and restarted the H2 generator. We ran out of H2 from the cylinders between 14:55 and 16:35.
6/29/11	62	NA	NA	Richard replaced and calibrated N analyzer.
6/30/11	63	NA	NA	Feed increased to 14 gpm at 12:17. Sparge at 16:00.
7/1/11	64	CA	--	Feed flow was at 14 gpm. Added 500 ml of 12.5% phosphate and 2 gallons of influent water to phosphate feed tank. The flow rate on the side reactors was reduced from 3 to 2.5 gpm.
7/1/11	64	NA	NA	Feed increased from 14 to 16 gpm at 13:55.
7/2/11	65	NA	NA	Reactors swapped positions at 12 am this morning. R1 is currently the lead reactor.

Date	Day	Operator	Lead Reactor	Notes
7/3/11	66	NA	NA	Sparge at 21:53 (Sparge process interval changed from 96hr to 24hr interval). After sparge, we got the Rialto R1 High Level and Rialto R2 High Level alarm at 23:13 and system shut down which led to hydrogen generator shutting down and therefore we are running on H2 cylinders.
7/4/11	67	NA	NA	David restarted the system at 8am. Sparge at 21:00.
7/5/11	68	CA	MBfR1	Nitrate standard was tested. Solution required a 1:10 dilution to be performed 3 times, to a concentration of 0.25. Results showed 0.25 on colorimeter. Lab samples will include monthly samples per line item 24. APT instructed CDM to open media filter flow valve to increase flow from 13 gpm to 15 gpm. CDM also restarted hydrogen generator at 10:30. The hydrogen generator had shut off on Monday. Chlorine and phosphate tanks have been refilled. CDM added additional clamp between GAC vessels to help stop the small leak there. No leak appears to be forming. The large CO2 tank has low pressure (10 psi). System currently running on small cylinder.
7/5/11	68	NA	NA	R2 H2 P increased from 18 to 21 psig at 16:15. Regular Sparge was initiated at 21:00. Feed pump tripped after the sparge process; therefore, there was no feed flow to the system.
7/6/11	69	NA	NA	Reactors swapped positions at 12am (R2 is lead). Richard worked on system: He restarted the system (he got the feed pump working again), calibrated the pH and ORP probes, and calibrated the Nitrate Analyzer. Regular Sparge initiated at 21:00.
7/7/11	70	CA	--	CDM onsite to fill phosphate tank with 2.3 gallons of influent water only. Check chlorine residual in media filter effluent (2.0 ppm) and in the product tank (<1.0 ppm, but did show a faint pink color). Also swapped gauges on GAC and IX systems. GAC gauge range is now 0-60 psi and IX ranges from 0-15 psi.
7/7/11	70	NA	NA	At 15:15, R2 H2 P was increased from 21 to 24 psig. Regular Sparge at 21:00.
7/8/11	71	NA	NA	We initiated the sparge process to measure the Nitrogen consumption before and after the new regulator was installed: 1scfm/module (old regulator), 12 scfm/module (new regulator). Richard had to replace the feed flow meter with the flow meter on the media filter. The media filter will be shut down over the weekend.
7/10/11	73	NA	NA	Reactors swapped position at 12 am (R1 is lead). R1 H2 P was increased from 12 to 14 psig at about 21:30.
7/11/11	74	CA	MBfR1	APT had informed CDM that media filters are not operating and water from aeration tank is bypassed to sump. No samples will be collected for the media filter or product tank. Cameron weld had been notified of low CO2 levels; they will be onsite 7/12 for replacement. APT had instructed CDM to take the pH and ORP readings at the reactor's overflow. Sample results summarized as: R1 overflow - pH: 7.64, ORP: -220, temperature: 20.2; R2 overflow - pH: 7.56, ORP: -420, temperature: 20.4. CDM changed bag filters for GAC/IX system since it was reading a 10 psi differential pressure.
7/11/11	74	NA	NA	Accidental Rialto High Sump Level alarm at 10:24. System was restarted at 10:48. Regular sparge initiated at 15:45. Feed flow increased from 16 to 18 gpm at 22:38.
7/13/11	76	NA	NA	Regular sparge at 15:00.

Date	Day	Operator	Lead Reactor	Notes
7/14/11	77	NA	NA	Reactors swapped position at 12 am (R2 is the lead). Ryan and Renato worked on system: we connected CO2 dewar and new CO2 cylinder to system, replaced N analyzer and calibrated it, changed clear tubing for black tubing going to lab reactors, installed filter flow meter (we realized filter inlet pressure transmitter was not working, therefore, we set zero flow through filter), clean and calibrated pH/ORP probes, ran sparge process at 21:00, and added line to allow more flow through pH/ORP probes bypassing lab reactors. Sparge process Interval set to 48 hr.
7/16/11	79	NA	NA	Regular sparge initiated at 21:00. At 23:00 we got a Rialto High Sump Level alarm.
7/17/11	80	NA	NA	Rialto High Sump Level alarm came at 1:00, 1:52, and 9:27. Feed Flow was decreased to 16 gpm, 14 gpm (R1 H2 P from 14 to 11 psig and R2 H2 P from 24 to 20 psig) and 10 gpm (R1 H2 P from 11 to 9 psig and R2 H2 P from 20 to 12 psig) at 8:45, 14:46, and 22:48 respectively. Hydrogen pressure decreased to prevent overreduction.
7/18/11	81	DB		Flow rate read 10 gpm upon arrival. APT lowered feed rate on 7/17/11 due to high sump level alarm. Bag filter was full of slimy biomass and preventing adequate flow. This caused the sump to back up. CDM changed out the bag filter and set the valve configuration to run in parallel. Did not collect daily field sampling or weekly lab sampling. Sampled for weekly permit compliance in addition the VOCs on GAC-1 for backup data. Sampled MBfR backwash water for TSS, for a total of 4 composite backwash samples. The target flow rate was set to 18 gpm. Briefly stopped influent feed pump to repair-tighten a slow lead on the pump discharge plumbing. Added 500 ml of phosphoric acid and 2.7 gallons of feed water. Phosphate was read using the field test kit from the influent strainer (post injection) as 5 ppm-PO4 prior to addition of phosphoric acid. A second reading was taken 30 minutes after adding phosphate and the reading was 5 ppm-PO4. Feed flow was increased to 18gpm at 8:36. R1 H2 P was increased from 9 to 14 psig and R2 H2 P from 12 to 24 psig at 10:05. Daniel initiated sparge process at 12:05.
7/19/11	82	NA	NA	18:45 - Turned up H2 on the Lead, R1 from 14 to 16 psig.
7/20/11	83	NA	NA	At 9:51 we got a Stage 2 Pump Fail alarm. Rialto R2 Water Flow LO-LO alarm at 10:16. R2 was down until 17:52. Sparge Process initiated at 21:00.
7/21/11	84	NA	NA	R1 H2 P was increased from 16 to 20 psig at 9:20. Feed was increased from 18 to 20 gpm at 13:04.
7/22/11	85	NA	NA	Reactor swapped position at 12:00am (R2 is lead). Richard and Renato worked on system. Regular Sparge Process at 21:21.
7/24/11	87	NA	NA	R2 H2 P was increased from 24 to 28 psig at 20:10. Regular Sparge Process at 21:00, however, R1 NOx wouldn't go below 0.6 because no flow from R1 (Lag Reactor) was going to the N analyzer and therefore Sparge process never ended.

Date	Day	Operator	Lead Reactor	Notes
7/25/11	88	CA	MBfR2	Influent flow to MBfR reactors was 0.0 gpm upon arrival at the site. The recirculation pumps were operating at 210 gpm. CDM contacted ATP to determine cause. APT instructed CDM to hold off on water sampling until the afternoon. CDM called Test America to change pick up time. Inspected the phosphate tank and discovered the tank was empty. Upon filling the tank, there was a leak at the fitting that connects the tank to the pump intake line. CDM removed tubing and repaired the leak, then primed the pump and restarted the phosphate injection pump. CDM changed both bag filters, 100/50 in one and 200/100 in the other, and placed them both online in parallel configuration. The differential pressure prior to change out was 12 psi, after change out it was 3 psi. APT confirmed that the MBfR configuration changed to MBfR 2 in the lead. Samples were collected from SP-100A and SP-200B. APT informed CDM that sampling SP-100B and SP-200A will require shutting nitrate analyzer feed before opening the sample port. This will prevent draining the analyzer. APT instructed CDM on how to remove air-pockets from the lines if this occurs. CDM needs to also check the nitrate analyzer discharge at the aeration tank for steady flow. APT installed a new nitrate analyzer, and CDM was not able to locate the frequency for the analyzer on the HMI display. At 09:19 we got system running at 20gpm again.
7/26/11	89	NA	NA	Reactors swapped positions at 12am (R1 is lead). No constant flow through N analyzer during the day because there is low pressure (purely hydrostatic pressure exerted by the height of the water in the tanks) at new sample locations going to the N analyzer installed on 7/22/11 . Regular Sparge was initiated at 21:00.
7/27/11	90	NA	NA	R1 (LEAD) Sample Valve was positioned in "hand" at 10:34. We sparged Nitrogen in Feed Tank from 13:15-17:11 and NOx in R1 dropped significantly. Manual Sparge was initiated at 23:00.
7/29/11	92	CA		CDM on site to refill phosphate feed tank. Checked chemical levels. APT on site and system is off. APT is upsizing MBfR effluent from 2" to 3" and is adding a valve. CDM determined phosphate feed pump has lost prime during the week and was not operating correctly. Current level of tank is 4.25 gallons. Cameron Welding was on site to refill N2 tank. Work order will be scanned and sent out to Jen. Sodium-Hypo tank was not refilled due to system not in operation. Richard worked on system, he did the following: 1) He changed the overflow line from 2" to 3" to get higher feed flow capability. 2) He rerouted samples lines so it wouldn't vapor lock. We started another Feed Tank N2 Sparge experiment at 16:00 (N2 flow =3cf/min) to remove the dissolved oxygen (DO) in the feed. Filter flow increased from 15 to 18 gpm at 22:00.
7/30/11	93	NA	NA	Reactors swapped position at 12 am (R2 is lead). Regular sparge process at 21:00.

Date	Day	Operator	Lead Reactor	Notes
8/1/11	95	CA	MBfR2	Observed icing on nitrogen tank. Contacted Cameron Welding - they will be on site today to check N2 tank and replace CO2 Dewar. Phosphate injection tank feed line requires replacement. Phosphate not injecting at this point. APT has instructed CDM to increase pressure for CO2 feed by adjusting regulator. Feed pressure for CO2 is now at 60-65 psi. Cameron Welding delivered CO2 cylinder and will bring the Dewar tomorrow. Cameron Welding instructed CDM to de-ice N2 tank and feed line. Pressure builder valve has been opened to increase pressure in the nitrogen. CDM to confirm in few hours if pressure has gone up. Current N tank pressure is 105. Pressure did not increase as of 5:00 pm and remains at 105 psi. We ran out of CO2 around 4 am. CO2 flow was restarted at 10:12.
8/2/11	96	CA	MBfR2	CDM made site visit to close nitrogen sparge valve on product tank. Cameron welding refilled nitrogen tank and delivered CO2 Dewar. CDM requested to perform a backwash on the media filters. APT instructed CDM to empty reject tank. In order to drain tank completely, the floats in the sump tank had to be manually tripped. This allowed the sump tank to drain enough so the reject tank float valve would drop enough to allow flow from the reject tank. CDM informed APT about lowering the level of the float switch so this will not occur at the next backwash. APT conducted the backwash and CDM collected a composite sample from TSS. Feed tank N2 sparge was turned off at 11:30. We got a Rialto High Sump Level at 13:08 by accident. Filter Backwash was initiated by Clyde from 14:48-15:10. Feed flow was decreased from 22 gpm to 20 gpm at 16:48.
8/3/11	97	NA	NA	Reactors swapped positions at 12:00 am (R1 is the lead). Regular Sparge Process at 21:00.
8/4/11	98	NA	NA	Richard worked on system. He did the following: 1) Installed new feed control valve. 2) Cleaned sump pump. 3) Calibrated H2 sensors on H2 generator and MBfR skid. 4) Changed air filter on H2 generator. 5) Calibrated pH probes.
8/5/11	99	CA		CDM on site to top off phosphate feed tank. Batch reaction experiment in lead reactor from 17:08 - 18:16.
8/6/11	100	NA	NA	Regular sparge was initiated at 12:00.
8/7/11	101	NA	NA	Reactors swapped positions at 12:00am (R2 is the lead).
8/8/11	102	CA	MBfR2	Chlorinator feed pump has minor leak at discharge connection. It has been repaired. The post finish water system has a larger discharge pressure (19-20 psi). A larger differential pressure across the system is recorded. CDM and APT have coordinated a sparge at 12:00 pm. CDM has taken TSS samples throughout the sparge process. Regular sparge was initiated at 12:00 pm (Clyde collected samples from Sparge process for TSS and turbidity analysis).
8/10/11	104	NA	NA	Regular sparge was initiated at 12:00.

Date	Day	Operator	Lead Reactor	Notes
8/11/11	105	DB	MBfR1	CDM onsite to perform conductivity tracer test on lag reactor (R2). Mixed 14 pounds of Mortons salt with 1.7 gallons of DI water in carboy. The salt never fully dissolved. Carboy sat in the sun for 3 hours while occasionally stirring but solution never dissolved. It was determined the solution was above the saturation limit of salt in water. CDM abandoned experiment and updated mixing calculations for run tracer experiment later. Conductivity of DI water was 2.25 $\mu\text{S}/\text{cm}$, baseline conductivity on lag reactor was 392 $\mu\text{S}/\text{cm}$. Reactors swapped positions at 12:00am (R1 is the lead). Rialto Secondary Containment Level High alarm at 19:26 caused by a barb hose fitting popping loose.
8/12/11	106	NA	NA	Richard and Rich working on the system, they did the following: 1) Repaired the leak 2) Measured NO _x at different spots in the tanks 3) calibrated pH probes. System was restarted ~9:30. Manual sparge was initiated at 14:43. Feed flow was decreased from 20 to 18 gpm at 16:34 to make sure we are removing all the Perchlorate.
8/14/11	108	NA	NA	Regular sparge was initiated at 14:00.
8/15/11	109	CA	MBfR2	Conducted tracer test using 1.7 gallons of DI water and 4 pounds 112 ounces of salt. Placed mixture in carboy and placed outside in the sun to increase speed of dissolving; mixed and stirred vigorously as well. Tracer test initiated at 12:00 pm. Baseline readings were approximately 400 $\mu\text{S}/\text{cm}$. Concentration was 1548 $\mu\text{S}/\text{cm}$ after first 15 minutes, subsequent readings tailed off fairly quickly (within 1.5 hours). The CO ₂ Dewar is empty. CDM contacted Cameron for refill. DP gauge is assumed to be malfunctioning due to air in the tubing caused by cycling of the sump pump. CDM and APT to investigate. Reactors swapped positions at 12:00am (R2 is the lead). We tuned the feed flow PID controller to get rid of noise in feed flow.
8/16/11	110	NA	NA	Regular sparge was initiated at 14:00.
8/17/11	111	CA	MBfR2	Cameron Welding onsite to replaced CO ₂ Dewar and cylinders. Upon reinstall of the CO ₂ Dewar, the pressure regulator read 0 psi, but it is full. Adjusted the knob on the regulator but the reading was not affected. The regulator may need replacement. Level on tank reads full. The CO ₂ pressure to the system is 88 psi.
8/18/11	112	NA	NA	Regular sparge was initiated at 14:00. Rich worked on system: He did the following: 1) Harvested 2 sample reactors (one from each side) and shipped them in a cooler overnight to ASU. 2) Calibrated pH probes.

Date	Day	Operator	Lead Reactor	Notes
8/19/11	113	DB	MBfR1	Calgon on site at 8:45 am to pick up disposorbs and spend GAC/IX in supersacks. APT on site to perform maintenance duties on the system. CDM did not replace bag filters since we agreed to wait until the sump pumping frequency increases. Performed a backwash on the media filter. A composite sample was collected and sent for TSS analysis. The composite turbidity was 48.0 NTU and the purge turbidity was 0.6 NTU. Sampled from the product tank (finished water) for threshold odor number, HAAs, and THMs. Optimization started today. The phosphate reading at the strainer was 2.0 ppm. Reactors swapped positions at 12:00am (R1 is the lead). Rich worked on the system. He did the following: 1) Calibrated ORP probes. Daniel initiated manual filter backwash at 12:40 to collect samples for TSS analysis. The operating conditions were changed to the following: Feed flow = 15gpm, R1&R2 recirc = 280 gpm, R1 H2 P from 20 to 17 and R2 H2 P from 28 to 25 psig to keep the H2 Supply:H2 demand ratio constant.
8/20/11	114	NA	NA	Regular sparge was initiated at 14:00.
8/21/11	115	NA	NA	We got the Rialto High Sump Level alarm at 10:40. The leak came from one of our sample reactors on the Reactor 2 side due to a hose feeding popping off its hose barb. The containment area got completely full because the Secondary Containment Level High alarm was disabled (presumably it was left disabled the time we had the leak on August 11-12) in order to run the system while the earlier-contained water was to be evaporated.
8/22/11	116	CB	NA	System offline due to leak. Containment area was completely full with many pumps and other equipment partially underwater. Area around the containment area was saturated due to either overflow or a leak in the containment walls. The well was in the "AUTO" position (normally in AUTO), but was not operating because the "hi level" alarm indicator was illuminated, most likely triggered by the secondary containment high level alarm. The feed tank and product tanks were full. The Aeration tank was 90% full, the sump was 75% full, the reject tank was 10-25% full, and the two MBfR reactors were 75% full. The IX and GAC containment was empty. There were no obvious leaks when the system was off. The valves and sample ports were in their normal position. The leaves in the tanks were steady. A water sample was collected from the secondary containment for perchlorate analysis. The area of soil saturated on the outside of the containment area was delineated using spray paint, and photos were collected. Rich used pump to remove water from the containment.
8/23/11	117	NA	NA	Richard and Rich checked pumps and other equipment for water damage (sump pump was damaged). Added a total of 72 clamps to secure hoses onto barb.

Date	Day	Operator	Lead Reactor	Notes
8/24/11	118	NA	NA	Prior to restart, Rich did the following: 1) Installed a replacement sump pump. 2) Modified both of CDM's level switches to trigger at a lower level (main containment area and conex trailer). 3) Added an additional, redundant level switch into APT's circuit that will shutdown the skid. And Ryan loaded a modified program so that if any shutdown alarm is disabled, it will send an email after 1 hour to remind us that it is disabled. If that alarm is not acknowledged within 1 hr, then the shutdown alarms will automatically be re-enable. System was restarted around 16:00.
8/26/11	120	DB	MBfR2	Collected weekly and monthly samples for permit compliance at 13:00. APT was onsite and finished cleaning up the site from the leak. The aeration tank compressor was not pumping as much air (SCFM) as was typical. APT inspected the compressor and removed a clog in the line. APT confirmed that the compressor was under water during the overflow incident. Lower DO values were seen across the media filter and finished water. The compressor readings were back to 2.1 psi and 3.1 SCFM after the block was removed. Turbidity was higher on the finished water compared to the filter effluent. A duplicate finished water sample was collected and the turbidity results were similar. The phosphate tank level did not change throughout the day because the pump was off. The reset button on the GFCI outlet was not punctuated. Pump started upon resetting the outlet. CDM primed the pump and verified flow. We got a power outage between 16:19-16:35. Regular sparge process was initiated at 20:00.
8/28/11	122	NA	NA	Regular sparge process was initiated at 20:00. We got the Rialto LEL Detector alarm at 23:21 which shut down the system.
8/29/11	123	DB	NA	System offline due to hydrogen LEL sensor being triggered at approximately 10 pm on 8/28. CDM notified APT immediately and then restarted the MBfR. The LEL 2 sensor was reading 5 to 6 % so the lines were checked for leaks by using soapy water. CDM located and tightened 4 leaks on the sample reactor hydrogen connections. The LEL sensor primarily displayed 0 % but periodically jumped back to 5-6 %. APT to arrive on site in the afternoon to investigate further. No samples were collected due to system being offline. On 8/27 the hydrogen generator was down for a period in the morning, and was manually restarted by APT. Daniel restarted the system at 9:00. Rich onsite to calibrate LEL sensors and to bubble-check all H2 fittings for external leaks (Daniel has started this and found a couple leaks on fittings on the Sample reactors). Rialto LEL detector alarm at 23:13.
8/30/11	124	NA	NA	APT started system at 8:34. We dropped the R2 H2 pressure from 25 to 21 psi to match the previous ratio (the ratio that we want). We noticed that R2 (lag) has some exposed fiber now that we are running at a lower feed flow rate. This is a consequence of lowering the overflow line to accommodate the higher flows (~23 gpm). We throttled the 3" valve on the overflow line in order to bring the level over the fibers. These exposed fibers could be contributing to our higher H2 flows in the Lag reactor and the LEL detector tripping. Filter backwash was initiated by Rich at 11:44. Regular sparge at 20:00.

Date	Day	Operator	Lead Reactor	Notes
8/31/11	125	CA	MBfR2	<p>Sodium hypochlorite pump was off in the morning. CDM plugged it back in. APT has explained that a leak was detected at the sodium hypochlorite injection point and was closed yesterday before he left. Kamron (RWQCB) on site at 10:00. CDM gave him a tour and walked through the process. Kamron took photos of the system. Rich was on site to test and install the filter aid pump. Rich started the filter aid pump at 1:55 pm, dosing rate is 3 ml/min at 0.5 mg/L and a feed concentration of 0.1 %. CDM and APT tested the new level that the secondary containment switch float is triggered. CDM determined the rope on the float switch will not engage when inverted due to the size of the float (3" round cylinder). The rope must be lengthened for it to be engaged. CDM/APT has lengthened the rope and lowered the pivot/connection point. Float now engages at approx 7 to 8 inches of standing water. APT will install another level switch that will engage at 4 to 5 inches.</p> <p>Reactors swapped positions at midnight (R2 is in the lead). Richard calibrated pH and ORP probes. We got the Rialto Secondary Containment Level High alarm at 12:58 by accident because the well pump was left in hand. Water was removed and system was restarted at 13:22. Initiated manual sparge at 16:35.</p>
9/2/11	127	DB	MBfR2	<p>APT onsite to refill filter aid and adjust pump settings. CDM performed backwash on MBfR and took turbidity measurements. Test America did not organize a courier pick-up today. They will send someone from the lab to pick up at the CDM Rancho Office later today or Tuesday morning.</p> <p>Rich tripled the filter aid concentration addition as compared to the original value (conc.=3 g/L, flow rate=3 ml/min) around 11:30. Manual sparge was initiated at 12:28.</p>
9/4/11	129	NA	NA	Reactors swapped positions at 12 am (R1 is the lead). Regular sparge at 13:00.
9/6/11	131	NA	NA	Decreased R1 H2 pressure from 17 to 15 psig at 11:48 to keep same H2 ratio; on Sep 4 reactors swapped positions and R1 (lead) and H2 ratio went from 1.2 to 1.4. Rich initiated backwash at 12:55. Regular sparge at 15:00.
9/7/11	132	CA		<p>Richard and Rich (APT) onsite to check performance of the coagulant pump. Media filter has a differential pressure of 4.5 psi (normally 2 - 2.5 psi). APT requested that the CO2 Dewar delivery pressure be lowered to 75 psi from 105 psi; CDM changed it to 75 psi. APT off site at 11:30. At 13:50 APT instructed CDM to lower feed flow rate from 15 to 10 gpm. This was the first day of new test conditions with the influent flow at 10 gpm and the MBfR recycle flow at 280 gpm. CDM adjusted the feed flow at 13:53 the OIT and adjusted the overflow valve between the MBfR and Aeration tank. CDM also reduced the media filter flow rate to 9.0 gpm by throttling the valve between the media filter and product tank.</p> <p>Richard (APT) changed lines to nitrate analyzer from 1/4" to 3/8". Media filter feed was decreased from 14 to 7 gpm at 15:28. R1 H2 P was decreased from 15 to 12 psig and R2 H2 P from 19 to 15 psig at 15:40 to adjust the H2 supply/H2 demand ratios after feed to MBfR was dropped. Manual sparge was initiated at 16:00.</p>

Date	Day	Operator	Lead Reactor	Notes
9/8/11	133	NA	NA	There was an accidental filter backwash at 9:40. Rich was onsite, he did the following: 1) Measured the flow of the Nitrate analyzer effluent (R1 = 144 ml/min, R2= 208 ml/min, feed= 5530 ml/min). 2) Cleaned the Nitrate Analyzer (we will do this in a weekly basis). 3) Fixed the position of the throttled valve in the media filter. Increased R1 H2 P from 12 to 13 psi at 13:52 to adjust R1 H2 supply/demand ratio. Rich and Ryan onsite: Rich increased the filter aid dosing (conc.= 8 g/L, flow rate=3 ml/min) around 19:00. Ryan turned the bypass flow in the pH loop OFF.
9/9/11	134	CA	MBfR2	CDM onsite at 8:00 to install sunshade on gas pad. APT instructed CDM to close media filter valve just enough to maintain 30 psi when backwashing. APT informed CDM not to perform the backwash due to the recent backwash yesterday. During the sparge process, the H2 LEL alarm had gone on and was at 37% during step 2, for the lag sparge. Aeration tank level was lower and CDM noticed white film inside of the tank and collected photos. CDM collected samples (bypass flow OFF, lab reactors flow ON). Clyde manually initiated sparge at 12:08 and collected MBfR sparge samples. Rich changed the injection point of the filter aid to the pump discharge around 16:00.
9/11/11	136	NA	NA	Regular sparge at 12:00.
9/12/11	137	CA	MBfR1	Reactors swapped positions at 12 am (R1 is the lead). Filter backwash was initiated at 04:20 because dP got higher than set point of 10psig. CDM noted that the coagulant pump was empty when arriving to site. CDM accidentally engaged the secondary containment switch when trying to install a new level switch. Replaced old level switch; will have CCI help to install. The system was shut-off; CDM restarted the system shortly thereafter. CDM changed the chlorine feed to 40 strokes per minute and 100% stroke length for an approximate flow rate of 7.5 ml/min and dose of 2.7 mg/L of chlorine. A light yellow ppt was accumulating on the aeration tank and smelled of hydrogen sulfide. The film was also slimy. The H2S smell has been evident for about a week. The differential pressure has been increasing since filter aid was added, backflushed after 4 days online. APT will do a jar test and work with filter aid contractor to understand type and dosing requirements.
9/13/11	138	NA	NA	Rich cleaned mag flow meters, cleaned and calibrated on pH and ORP probes between 16:35-17:03.

Date	Day	Operator	Lead Reactor	Notes
9/14/11	139	DB	MBfR1	CCI attempted to install a new level switch for secondary containment but could not get the relays to work. APT was onsite to install a tarp to shade the sunny side (northern end) of the MBfRs. Did not perform a backwash because differential pressure on filter was less than 1 psi. APT tried to sparge the MBfR reactors, but the sparge did not complete properly because lag reactor (R2) wouldn't pump out. APT found water in a conduit - there was an open circuit on the neutral return leg that left 4 valves non-functional (stuck in their last position, XV-205,6,7 and the pullout valve, BV-210). The conduit was dried by sweeping n2 for an hour until no mist was coming out any more. The LSI was calculated for the lag reactor effluent, and calcium carbonate scaling was likely to occur, the yellow-ish ppt may have been calcium carbonate and some sulfur accumulation. The tarp covering the chlorine tank was not in place, which could lead to degradation of chlorine. The tarp was replaced. Increased sodium hypo pump settings to 60 spm and 100 % stroke length from 40 spm to increase the dose. Measured chlorine residual directly after media filter when these modifications were made, reading was 1.2 mg/L. CCI still on site when CDM left, troubleshooting the relays for the secondary containment high level switch. APT doubled the filter aid dosing (filter aid=16 g/L at 6 ml/min) at 12:30.
9/15/11	140	NA	NA	CCI on site, replaced CDM's level switch for secondary containment; tested that it functioned properly. APT increased flow to 18 gpm. APT onsite to inspect and troubleshoot the leak at the bottom of reactors problem and to finish drying the conduit. The stock solution for filter aid was doubled (32 g/L,6 ml/min) in the afternoon. Nitrate analyzer influent and effluent lines were modified (from bottom of tanks to discharge of recycle pumps) and operating conditions (feed = 10 -> 20gpm, R1 H2 P =13 -> 20, R2 H2 P = 15 -> 28psig) were changed in preparation for batch experiment.
9/16/11	141	DB	MBfR2	Reactors swapped positions at midnight (R2 is in the lead). CDM performed batch experiment. Batch test consisted of shutting off influent to MBfR and waiting to take perchlorate samples based on monitoring of nitrate levels on OIT screen. This was conducted for R2 and then R1. The o-rings securing the modules slipped and they are getting bypass. APT will remove the modules and replace the o-ring seal with a threaded seal next week. APT performed maintenance tasks and met with visitors interested in the technology. Flow changed to 5 gpm after field activities were complete. Water flowed through the lag reactor but the recycle and H2 was off to keep the reactor from stagnating. On Sunday APT will do a reactor sparge and then bypass the lag reactor. After sampling on Monday they will return to flow through the lag reactor. Sodium hypochlorite concentrations were lower than expected in the product tank, concentration of sodium hypo in the stock tank was doubled. Media filter backwash at 13:57. Sparge process at 14:00. After batch experiment, we started running on one reactor (R2, the lead) with the following conditions: Feed = 5 gpm, R2 H 2P = 10psig. Filter feed = 4.5 gpm. Filter aid (64 g/L, 3 ml/min).
9/17/11	142	NA	NA	Increased R2 H2 P from 10 to 13psig at 10:29.

Date	Day	Operator	Lead Reactor	Notes
9/18/11	143	NA	NA	Regular sparge at 14:00. Made effluent of lead reactor (R2) go straight to aeration tank and R1 recirc pump was turned off around 19:20.
9/19/11	144	DB	MBfR2	Only R2 is in operation today (intentionally). As such, samples were not collected from the lag reactor. The chlorine pump settings were accidentally left at 60spm on 9/16, so chlorine residual was high (>5) at the product tank - the ORP was 733 mV. The settings were reduced to 20 spm and 100% stoke length (4.3 ml/min); residual was 4 ppm 3 hours after this change was made. A sample was collected of the backwash water on Friday 9/16, and the differential pressure on the media filter was 9 psi today. This was likely due to increasing the dose of filter aid. The turbidimeter was calibrated on Friday 9/16 but was not compared to the low level standards. The online turbidimeter has a reading of 0 after backwashing - this is likely an artifact of the operation of the backwash pump interfering with the turbidity measurement rather than actual changes in turbidity. APT is still planning on replacing the reactor o-rings on Wednesday.
9/20/11	145	NA	MBfR1	Reactors swapped positions at 12am (R1 is the lead). Regular sparge at 14:00.
9/21/11	146	NA	NA	System was shutdown and the tanks were drained at 12:22am so that the modules can partially drip-dry by morning. APT onsite to work on fixing leak at the bottom of modules. System was restarted at 18:58. Sparge process was initiated at 19:43. Then system operating at the following conditions: Feed = 15 gpm, R1 recirc = 210 gpm, R2 recirc = 180gpm, R1 H2 P = 10, R2 H2 P=15psig, Filter feed = 4.5gpm.
9/22/11	147	NA	NA	APT onsite to work on the filter: They initiated media filter backwash to see how much flow they were getting. Piping on the filter will be modified to get correct flow when it backwashes. R1 H2 P was changed from 10 to 15psig at 09:56. Sparge process was initiated at 13:02. Filter feed flow set point changed to 9gpm. Sparge interval was set to 6hr. Regular Sparge process at 18:07.
9/23/11	148	NA	NA	Regular Sparge process at 12am. Regular Sparge process at 6:00. APT onsite to do the following: 1) Dried CO2 lumen MFC. 2) Changed bag filter to make sure it didn't trigger during the weekend. 3) Changed air filter on the H2 generator. Regular Sparge process at 12:00. Regular Sparge process at 18:00. R2 recirculation changed from 180 to 210 gpm at 20:47. Manual Sparge process at 20:55.
9/24/11	149	NA	NA	Regular Sparge process at 12 am, 6:00, 12:00 and 18:00.
9/25/11	150	NA	NA	Regular Sparge process at 12 am. Regular Sparge process at 6:00. Regular Sparge process at 12:00. Regular Sparge process at 18:00. R1&R2 recirculation changed to 280 gpm at 22:03. Manual Sparge process at 22:06. R2 H2 Flow rose steadily after the sparge which caused a Rialto LEL detector at 23:32.
9/26/11	151	NA	NA	Rich onsite to look for the H2 leak. System was restarted at 14:26. He was unable to find the leak. Feed dropped from 15 to 10 gpm at 17:00. R2 H2 P dropped from 15 to 13psig at 17:26. Regular sparge at 18:00. System shut down due to a Rialto LEL detector at 21:55.

Date	Day	Operator	Lead Reactor	Notes
9/27/11	152	NA	NA	Rich onsite to look for the H2 leak. System was restarted at 09:56. Rich found the problem. There is a large leak emanating from underneath R-206. We restarted the system with 6 of the 7 modules operating and will plan to pull R-206 from the tank tomorrow and fix it. R-206 H2 flow turned off. Regular sparge at 12:00 and 18:00.
9/28/11	153	NA	NA	The hydrogen leak that caused the most recent LEL alarm was caused by a mechanical failure on one of the lag modules. The epoxy head was delaminated from the core such that it was no longer connected. The reactor is being removed today, and another reactor from the lead MBfR will be removed. Samples of the membrane are being sent to ASU for analysis. Reactors swapped positions at 12am (R1 is the lead). Sparge at 12am and 6:00. APT onsite to remove leaky module on R2 (R2-206) and module on R1 (R1-103)...MBfR down from 8:51-18:51.
9/29/11	154	NA	NA	Sparge at 12am, 6:00, 12:00, and 18:00. APT onsite to install a 3-way directional valve and flow meter on the media filter to direct all the backwash to the media filter and eliminate any need for a throttled manual valve. NaOCl injection valve was plugged solid with precipitate.
9/30/11	155	NA	NA	Sparge at 12 am, 6:00 (Sparge Interval changed to 12 hr). Sparge at 18:00. APT to continue working on media filter. All four CO2 meters got wet yesterday in the CO2 supply change-out and one of the CO2 mass flow meters could not be dried and restarted to run stably afterwards. So, we borrowed the CO2 mass flow controller from the "R1 Lumen flow" and are using it for the bulk CO2 input for R1 pH control (thus the lumen CO2 flow is zero for R1). Current operating conditions: Feed=10gpm, R1 H2 P=15psig, R2 H2 P=13psig, R1&R2 recirculation = 180gpm, Filter flow = 9gpm.
10/1/11	156	NA	NA	Sparge at 6:00 and 18:00.
10/2/11	157	NA	NA	Reactors swapped positions at 12 am (R2 is the lead). Sparge at 6:00 and 18:00.
10/3/11	158	CA	MBfR2	Sparge at 6 am. Sparge interval changed to 24 hr. Backwash at 14:40 because dP got to set point of 10 psig. Valve XV-103 on MBfR 1 was unplugged. Leak on phosphate pump/tank was identified. Recirculation pump P-200 was operating very loudly. The chlorine pump injection valve was closed, CDM opened the valve.
10/4/11	159	NA	NA	Sparge at 6am. Rich onsite: Manual Backwash at 11:52. Rialto High Sump Level by accident at 12:28. Manual Backwash at 12:43. Rich vented the fibers at 13:54 which improved the performance (NOx in the lead dropped significantly). New Filter aid addition around 20:45: "950S" 3.4 g/L at 3 ml/min.

Date	Day	Operator	Lead Reactor	Notes
10/5/11	160	DB	MBfR2	Spurge at 6 am. Rich vented fibers at 8:05 which improved the performance (NOx in the lead dropped significantly). APT filled filter aid tank. System shut down at 14:35 because rain water tripped CDM's secondary containment level switch. The switched triggers at 2 inches of water. CDM pumped water out of secondary containment and discharged it to the ground (rain water only). CDM elevated this secondary containment switch to 4 inches temporarily to prevent another system shut down. CDM restarted the system at 15:44. To mitigate accumulation of rainwater into secondary containment, the southern secondary containment wall was temporarily wedged inward slightly to break the connection between the conex box and the inside of secondary containment. Water had been flowing down the side of the conex box during heavy rain and flowed directly into containment. A significant leak from the sodium hypochlorite pump discharge was emanating from a crack on the fitting connection. CDM placed epoxy on the fitting and allowed it to dry. Tested it after several hours and the fitting continued to leak. Rich ordered the part to be replaced. Replaced bag filter with 100/50 bags since dP was 13 psi.
10/6/11	161	CA	NA	Reactors swapped positions at 12 am (R1 is the lead). Spurge at 6 am. CDM onsite to install gutters on southern side of MBfR skid.
10/6/11	161	NA	NA	Reactors swapped positions at 12 am (R1 is the lead). Spurge at 6 am. Manual backwash at 12:16. Filter aid dose changed: 6.8 g/L at 1 ml/min.
10/7/11	162	CA	MBfR1	APT on site to vent moisture for gas lines. May affect gas pressure readings. CDM to collect turbidity sample and send to lab. CDM & APT noticed well PVC piping has moved, we have addressed issue w/placing sandbags. CDM conducted gas readings at points onsite. CDM to discuss sample installation on product tank line to sump. APT has reduced flow to 5 gpm. APT has refilled the filter aid solution. CDM unable to calibrate turbidimeter.
10/7/11	162	NA	NA	(Spurge Interval changed to 22hr). Spurge at 4am. Rich vented fiber drains at 9 am. Chlorine pump was turned on at 9:20. Manual backwash at 11:51. Rich installed R1 CO2 lumen MFC. Feed dropped from 10 to 5 gpm at 16:10 (Filter flow dropped to 4.5 gpm). Rialto R1 High Level alarm at 17:06. System restarted at 18:55.
10/8/11	163	NA	NA	Spurge at 2 am.
10/9/11	164	NA	NA	Spurge at 12 am. Backwash at 12:45 because dP got to setpoint of 10 psig. Spurge at 22:00.
10/10/11	165	CA	MBfR2	CDM noticed filter aid tank is empty. Alerted APT and shut off coagulant pump. CDM unable to take ORP at locations, probe needs to be replaced. CDM has measured gas - elevated CO levels were detected (~120ppm). CDM changed chlorine injection pump setting to 20 strokes per min w/100 % stroke length. Then change was made due to the high chlorine residual in the product tank (this was due to media filter flow rate being decreased to 4.5 gpm from 9 gpm).
10/10/11	165	NA	NA	Reactors swapped positions at 12 am (R2 is the lead).

Date	Day	Operator	Lead Reactor	Notes
10/11/11	166	NA	NA	Rich onsite: H2 initiated manual backwash at 10:30am. Rich did pH probe experiment but the data got lost (MBfR down from 10:55-14:07). Manual filter backwash initiated at 14:12 and 14:33. Sparge at 18:00. Ryan was onsite to add the turbidity wiring for new turbidimeter. The Turbidity is now displayed from both analyzers on the filtration page. Ryan turned the filter feed flow from 4.5 to 4gpm.
10/12/11	167	CA	MBfR2	CDM observed that new online turbidity meter was installed - however OIT and instrument readings do not match. Meter samples water from media filter effluent. A filter backwash was performed yesterday (10/11). A sparge was done at 12:15 pm and samples were taken. The system was shut down at 1:30pm. The pH meters were removed and tested against CDM handheld meter. CDM reset hydrogen generator. After taking chlorine residual (0.1 in product tank), CDM increased injection rate to 30 strokes per minute w/100% stroke length.
10/12/11	167	NA	NA	Clyde initiated sparge process at 12:21 to collect sparge samples. Clyde did pH probe experiment between 13:43-15:36. Regular sparge at 16:00. Sparge interval was changed to 24hrs. pH loop for both reactors was left closed.
10/13/11	168	NA	NA	Filter backwash on its own at 8:10 because dP got to setpoint of 10psig. Manual backwash at 17:00 and 17:30. System down from 14:32-17:39 (but R1&R2 recirc were turned on with R1&R2 water level low and blowing air to kill sulfate reducers). Manual sparge with air at 22:00. We forced R2 to be in the lead and R1 in the lag so we can compare tomorrow's samples to Monday's and Wednesday's.
10/14/11	169	DB	MBfR2	Sodium hypochlorite tank was left uncovered exposing it to light. CDM covered w/black trash bag and secured it to tank. Increased strokes per minute on chlorine pump to 40 (from 30). This elevated post media filter chlorine concentration to 4.5 ppm. CDM used silicon solution to prep sample vials during turbidimeter calibration and during sample analysis. New sample vials were used during today's analysis. Turbidimeter requires factory calibration and repair.
10/14/11	169	NA	NA	Regular sparge with air at 16:00. R2 & R1 were forced to stay in the lead and lag position respectively (program was modified). Feed was increased from 5 to 10gpm around 17:00. One of the modules in R-1 would not contain hydrogen so it was valved off and taken out of service and R1 recirc flow was dropped from 180 to 150gpm around 20:00.
10/15/11	170	NA	NA	Regular sparge with air at 16:00.
10/17/11	172	DB	MBfR2	Reactor 1 has two modules offline, Reactor 2 has one module offline (APT indicated that one of the R1 modules failed over the weekend so they shut it down). Sending turbidimeter in for factory service. Used 2100p model instead for today's analyses. Upon topping off chlorine tank, CDM reduced strokes per minute on pump to 30 (from 40). Covered tank w/black tarp after filling. Increased media filter flow rate to 9gpm (from 4).

Date	Day	Operator	Lead Reactor	Notes
10/19/11	174	CA	MBfR2	APT onsite to drain fibers on MBfR 1&2. APT also refilled filter aid. APT explained that N2 is no longer used in sparge and air compressor was installed in-line. APT was successful in repairing the leaky module from MBfR 1. The failure was not due to epoxy, it was found that the top nut was loose. APT reapplied o-ring and tightened the top nut. CDM and APT observed that site does have less pungent H2S smell. APT shut down filter aid at 12:30 - initial turbidity reading on in-line probe = 0.29. At 1:30, turbidity - 0.66 NTU. CDM monitored 4 gases (O2, H2S, CO, LEL). APT decided to try a new filter aid. Readings will be relayed from APT.
10/20/11	175	NA	NA	Rich onsite: filter backwash at 8:56. Rich vented fiber drains at 10:42. Sparge at 16:00. Manual Sparge at 18:00.
10/21/11	176	DB	MBfR2	Coagulant tank was empty upon arrival. CDM turned off coagulant metering pump, increased sodium hypo settings to 40 spm from 30 spm. Post sodium hypo injection residual was 1.5 ppm. Took 4-gas meter readings today, all gas readings were zero except oxygen (20.9). Conducted a sparge and collected TSS and turbidity samples.
10/22/11	177	NA	NA	Sparge at 16:00.
10/23/11	178	NA	NA	Increased R2 H2 P from 11.1 to 15psig at 14:53. Sparge at 16:00. R2 H2 shot up after the sparge.
10/24/11	179	NA	NA	APT repaired a loose nut connection on the top of an R2 module. H2 leak disappeared after tightening it up. APT installed a solenoid valves to be used for fiber purging. APT troubleshoot new turbidimeter. Changed sparge interval to 12hr (from 24). APT successfully vented fiber drains using solenoid valves.
10/25/11	180	NA	NA	Sparge at 03:00. R2 fibers' venting using solenoid valve at 13:30 (SV opened for 1 min). Sparge at 15:00.
10/26/11	181	DB	MBfR2	Took weekly samples, monthly influent compliance samples and duplicates.
10/27/11	182	NA	NA	Filter backwash at 12:18 because dP got to setpoint of 10psig. Sparge at 03:00. Manual Sparge at 08:05. We got a R2 High Level at 9:57. System restarted at 16:20. R1 H2 is not able to maintain the H2 pressure. At 20:27-20:44, R-105 was taken offline (R1 recirc dropped from 180 to 150gpm) because R-105 bottom H2 seal/o-ring/or core tube failed. At 22:15 Ryan corrected the (No Suggestions).
10/28/11	183	DB	MBfR2	APT onsite to rebuild recirc pump on R2. R1 valve leading to nitrate analyzer was left close since 10/27 causing a high nitrate analyzer reading. Upon opening, the nitrate analyzer stabilized at 0.23 ppm. CDM lowered secondary containment level switch back to 2" above containment floor (from 4").
10/28/11	183	NA	NA	Fiber drains venting was programmed into PLC: 1) The Fibers drains will currently open for 90 seconds. 2) R1 will open on the hour on every odd hour. 3) R2 will open on the hour on every even hour. 4) Neither will open if the sparge has been triggered or is in progress (to prevent losing out level indication / transmitter flow). R1 sample valve to N. Analyzer opened at 9:48. Richard replaced P200 between 11:53-17:48.

Date	Day	Operator	Lead Reactor	Notes
10/29/11	184	NA	NA	Sparge at 16:00. R1 fiber drain vented automatically at 19:00 for the first time.
10/30/11	185	NA	NA	Sparge at 03:00 and 15:00.
10/31/11	186	DB	MBfR2	Two modules were off on R1 and 1 module off on R2. Sodium hypo pump was off upon arrival (CDM turned it back on right away). Performed pH meter backcheck test today on all sample points using CDM's Oakton pH6+ field meter, A HACH Sension1 meter borrowed from CCI, and the inline pH probe APT has installed on the MBfR for R2. Results are shown in the table on the data log sheet. CDM took samples for daily monitoring tests after the pH test was performed, it appears that all pH values are lower due to the CO2 overshooting to compensate for the pH testing period. CDM confirmed with APT that during future pH tests using the inline probe, it is necessary to place the CO2 flow in 'hand' mode so that the CO2 does not overcompensate.
10/31/11	186	NA	NA	Sparge at 03:00. R2 fiber drain vented automatically at 10:00 for the first time because before that there was a mistake on the program.
11/1/11	187	NA	NA	APT opened R1 valve leading to nitrate analyzer (this was accidentally left closed upon sampling on 10/31/11). Regular Sparge process was initiated at 3:00 and 15:00. R1 sample valve at the bottom of the tank was opened around 18:30
11/2/11	188	CA	MBfR2	Very windy onsite. CDM does walk around to check for damage from wind. CDM lowered chlorine pump to 30 spm and 100 stroke length. CDM completed weekly sampling event to include duplicate samples. Regular sparge process was initiated at 03:00 and 15:00.
11/3/11	189	NA	NA	Regular sparge process was initiated at 03:00. Rich was onsite: He initiated a filter backwash at 8:38. After the backwash, Rich started dosing filter aid: SWT 2000. 3.25 g/L running at 17 ml/min. Regular sparge process was initiated at 15:00. Sparge interval was changed from 12 to 24 hr.
11/4/11	190	CA	MBfR2	APT onsite to adjust hydrogen LEL sensor. It is currently raining onsite and site is not flooded. CDM to monitor rain. APT complete LEL adjustment at 9:30, CDM will wait to for the system to stabilize prior to taking samples. APT increased filter aid dose: 6.5 g/L at 17 ml/min. LEL sensors in hydrogen generator were calibrated at 8:55. Clyde initiated the sparge process at 12:03. Regular sparge process was initiated at 15:00. Sparge interval was changed from 24 to 12 hr.
11/5/11	191	NA	NA	Regular sparge process was initiated at 03:00. R2 CO2 lumen valve was opened at 10:31 (ratio was set at 0.1). R2 H2 P was increased from 15 to 17 psig at 13:12 and from 17 to 17.5psig at 13:52 to keep R2 H2 flow the same. Regular sparge process was initiated at 15:00.
11/6/11	192	NA	NA	Due to Daylight Saving: R1 opens on the hour on every even hour. Nitrate analyzer samples R1 on every even hour. R2 opens on the hour on every odd hour. Nitrate analyzer samples R2 on every odd hour. Regular sparge process was initiated at 2:00 and 14:00 (an hour before scheduled time due to daylight savings). Filter backwash at 20:02 because dP got to 10 psig.

Date	Day	Operator	Lead Reactor	Notes
11/7/11	193	DB	MBfR2	Gallade chemical delivered 3 - 15 gallon carboys today of 12.5% sodium hypochlorite. APT to be onsite this afternoon to perform work on system. Regular sparge process was initiated at 02:00. PLC and OIT times were changed at 9:19 to correct for daylight savings: Fiber venting and Nitrate analyzer samples went back to their original time. Rich was onsite: 1) Started filter aid at 12:44 (it was under dosing), 2) Installed diffuser for turbidimeter around 14:15 3) Performed a manual sparge on R2 (one module at a time) between 15:53-17:16.
11/8/11	194	NA	NA	Rich was onsite: 1) Calibrated pH and ORP probes between 08:30-09:00. 2) Filter aid increased at 11:10 (6.5 g/L at 17 ml/min). Regular sparge process was initiated at 13:00.
11/9/11	195	DB	MBfR2	APT installed larger coagulation container (~15 gallons) but the pump was off, not feeding the system. Turbidity was low on both APT instrument (0,21). So there does not appear to be a need for coagulation dosing at this point. Regular sparge process was initiated at 01:00. Filter backwash at 9:46 because dP got to 10 psig. Regular sparge process was initiated at 13:00.
11/10/11	196	NA	NA	Regular sparge process was initiated at 01:00. Filter backwash at 9:46 because dP got to 10 psig. Regular sparge process was initiated at 13:00.
11/11/11	197	CA	MBfR2	CDM onsite, a slight smell of sulfur/sulfide in MBfR and aeration area. CDM performed sparge at 12:00. Samples were taken for TSS. CDM cleaned nitrate analyzer lens with DI water and chem wipe. The Nitrate analyzer feed lines have been re-routed as per APT's direction. The nitrate analyzer numbers were taken before and after re-route. CDM refilled chlorine and change settings to 40 strokes per minute with 100% stroke length. Regular sparge process was initiated at 01:00. Rich opened the R1 sample valve at the bottom of the tank around 7 am. Clyde initiated manual sparge at 11:50. Clyde modified Nit. Analyzer influent lines in preparation for next week's batch test. Renato manually did a sparge on R2 (first decreased R2 recirc rate to 70 gpm and R2 H2 P to 14 psig) at 16:50. Sparge interval was changed to 4hr. Filter did a backwash on its own at 19:15 because dP got to 10 psig. Regular sparge process was initiated at 21:00.
11/12/11	198	NA	NA	Regular sparge process was initiated at 00:00, 04:00, 08:00, 12:00, 16:00, 20:00. David did a manual sparge on R2 around 10:45.
11/13/11	199	NA	NA	Regular sparge process was initiated at 00:00, 04:00. No more sparges after that because "Reject tank is NOT ready to receive." (Water is not flowing from the Reject tank to the Sump tank). R2 recirc was changed back to its original setpoint of 180gpm at 08:20. R2 H2 P was changed back to its original setpoint of 17.5 psig at 14:58.

Date	Day	Operator	Lead Reactor	Notes
11/14/11	200	CA	MBfR2	<p>Schedule batch test for today. CDM was instructed to close the reject tank sump pump valve. During the weekend the reject line had become clogged not allowing it to drain. The MBfR has not been able to sparge since Saturday. CDM closed filter aid feed due to leak at the pump head. Batch testing started @ 9:35. Alarms for high level has stopped the test. CDM restarts test @ 10:30.</p> <p>First day of the batch experiment on R2. Filter aid was leaking at the head so Clyde decided to turn it off. High Sump Level alarm at 16:07. Rich was onsite at night: He found the Sump Tank level switch outside the sump tank and the sump pump never turned on which caused the High Sump Level. Apparently what happened is that Inventory water from the MBfR flowed into the sump tank and overflowed into the secondary containment which caused a level switch on the secondary containment to trip shutting down the well pump. Rich restarted the system at 21:12 but the well pump alarm was never cleared; therefore, the water going to the MBfR after being restarted was the remaining water in the feed tank.</p>
11/15/11	201	NA	NA	<p>Regular sparge process was initiated at 00:00 but it never finished because there was not enough water in the feed tank to refill the MBfR completely. The system was still running with no incoming water. A decision was made to not do the second day of the batch experiment. Rich was onsite: 1) Cleared the Well pump alarm and got water flowing back into the MBfR at 9:12. 2) Did a manual sparge on R2. The result was that R2 dP dropped from ~38-39 psig to ~25-26 psig.</p> <p>3) Replaced the tubing on the filter aid pump and restarted it. Filter did a backwash on its own at 21:39 because dP got to setpoint of 10 psig. Went back to sparging with nitrogen.</p>
11/16/11	202	CA	MBfR2	<p>CDM onsite at 8:00am. The system is operating normal since 11/15/11. CDM to conduct batch test on reactor 1. Lead reactor is currently #2. CDM to follow steps 38-71 on Batch test protocol. Testing started @9:29. A leak was found on recirculation pump#2. It is the source of flooding the site. Batch testing ends @ 3:40. CDM returns all settings back as described in step 71. Nitrate analyzer lines were returned to their normal sampling port. CDM set sparge back to 12 hour interval and immediately initiated a sparge. CDM stayed onsite to monitor. CDM also removed flooded water. Level on reactors appear to be stable at 4-inches below the high level alarm. Cameron Welding onsite to refill nitrogen dewar.</p> <p>Note: APT informed me that the reject tank has approximately 4 to 6-inches of filter media in the bottom. We have calculated the total volume to be 2-4 cubic feet of media. The filters only contain 8 cu-ft of media. The backwash may be causing this.</p> <p>Second day of the batch experiment on R1. Clyde informed that P200 is leaking. Richard Rossi will be onsite on Saturday to replace the seal on the pump. Sparge process at 16:33.</p>
11/17/11	203	NA	NA	<p>Sparge at 04:00 (with Nitrogen instead of air since 11/15/11). Rich calibrated the pH and ORP probes for both reactors. Sparge at 16:10.</p>

Date	Day	Operator	Lead Reactor	Notes
11/18/11	204	DB	MBfR2	Coagulant tank was empty upon arrival. Coagulant pump was running but not dosing system so CDM turned off pump. Sparge at 04:00. Sparge at 16:00. R2 H2 P was changed from 17.5 to 15.5psig at 21:49 to keep the same H2 flow was as before.
11/19/11	205	NA	NA	Sparge at 04:00. Richard was onsite: He worked on the P-200 from 9:36-13:00 (all was well for one hour then the new seal began to leak). Sparge at 16:00 but it didn't finish (Sparge timeout at 16:39) because it couldn't complete all the steps for R2. R2 H2 P couldn't maintain pressure so H2 flow to R2 was shut down.
11/20/11	206	NA	NA	Richard onsite: Worked on the P-200 from 8:55-10:30 (the seal leak appears to be resolved). He replaced the H2 generator filter.
11/21/11	207	NA	NA	System shut down on a R2 High Level at 01:27. Rich was onsite, he did the following: Restarted system at 12:03. Filter aid started around 13:30 (SWT2000). Sparge at 16:00
11/22/11	208	CA	MBfR2	APT lowered influent flow rate to 8 gpm. CDM changed phosphate dosing to 20 strokes per minute / 25% stroke rate. Changed sodium hypo dosing to 30 spm / 100 %. The reactor overflow valve to the aeration tank was slightly closed to compensate for lower flow and maintain water level in the reactors. Feed flow changed from 10 to 8 gpm in preparation for the 4 weeks of steady state starting Monday November 28. Filter flow was also dropped from 9 to 7.5 gpm.
11/23/11	209	NA	NA	Rich was onsite, he did the following: Rich found a leak from the bottom of R2 207. R-207 was taken offline at 7:48. R2 recirc dropped from 180 to 150gpm at 10:09. Calibrated turbidity meter ((No Suggestions)). Rich did a filter backwash at 12:32. At 14:45, R-204 was taken offline due to a leak coming from the top of the module. It delaminated. R2 recirc dropped from 150 to 120 gpm. Filter flow dropped from 7.5 to 7 gpm.
11/24/11	210	NA	NA	Sparge at 00:16 and 2:55 and 14:00. Sparge interval set at 12 hrs interval.
11/25/11	211	NA	NA	Sparge at 2:00 and 14:00.
11/26/11	212	NA	NA	Sparge at 2:00. Around 10:00, R2 H2 P changed from 15.5 to 18 psig. Sparge at 14:00.
11/27/11	213	NA	NA	Sparge at 2:00 and 14:00.
11/28/11	214	CA	MBfR2	CDM performed turbidity calibration, all standards do not read well and need to be reordered. APT informed CDM that bag filters were changed on 11/23/11. Sparge occurred at 2:00 pm. CDM to order more post-filters (250-100). CDM installed 100-50 type bag filters. Need to closely monitor DP. APT onsite to refill filter aid and harvest 2 fiber reactors (1 from each MBfR). Sparge at 2:00. Filter backwash at 12:04 because dP got to setpoint of 10 psig. Sparge at 14:00. Rich onsite: Rich sent two lab reactors to ASU. At 15:43 feed flow was dropped from 8 to 7gpm and filter flow from 7 to 6 gpm. Manually made reactors swap positions at 15:53 (R1 is in the lead)
11/29/11	215	NA	NA	Sparge at 02:00. Sparge at 14:00. Around 17:00, we set R1&R2 CO2 in the lumen to 0.05 of the H2 flow and changed R1 H2 P from 15 to 16.5 psig and R2 H2 P from 18 to 16.5psig to keep the same H2 flows.

Date	Day	Operator	Lead Reactor	Notes
11/30/11	216	DB	MBfR2	Increased phosphate dosing pump stroke length from 25% to 30. Coagulant tank was empty upon arrival, CDM turned off dosing pump and alerted APT. CDM turned down CL2 pump to 25spm (from 30) due to the lower media filter flow rate. Collected 10 gallons influent well water and 5 gallons flush (purge) water and sent them to ASU for overnight delivery. CDM had to manually initiate a sparge on MBfR and only collect sample water during the first drain/second drain for both reactors. Sparge at 02:00. Daniel collected well water (2x5 gal). Daniel manually initiated the sparge process at 13:10 to collect sparge water (5 gal) and sent it to ASU.
12/1/11	217	NA	NA	Sparge at 2:00. No feed water at 06:52 (no water in the feed tank) but system was still running so we started overreducing. Stopped system at 08:42 until Rich gets there. Rich onsite: Well pump had a high sump level alarm. The weather conditions triggered the level switch in the secondary containment (high winds)?. There was no water in the secondary containment. Alarm was cleared and water started flowing into the feed tank. System restarted at 9:18. Sparge at 14:00. Feed was dropped from 7 to 6gpm at 16:55. H2 generator shut down at 18:09
12/2/11	218	DB	NA	No sampling today as Wednesday's perchlorate lag samples did not show complete removal. CDM on site to top of phosphate and sodium hypo tanks. CDM restarted H2 generator and verified enough H2 in 6-pack to last through the weekend if generator shuts down again. Increased sodium hypo pump (spm) setting to 30 (from 25spm) after topping off tank. APT to be on site this afternoon to adjust ball valve setting on MBfR outfall (overflow to aeration) to account for lowered flow rate (6 gpm). CDM adjusted ball valve (APT to check on water level later today). Noticed some knocking or rougher sounds from sump pump (might consider servicing it). Reactors swapped positions at 12 am (R2 is in the lead). Sparge at 02:00. Daniel adjusted the overflow valve and restarted the H2 generator around 13:00. Sparge at 14:00. H2 generator shut down at 16:04.
12/3/11	219	NA	NA	Sparge at 02:00. Sparge at 14:00.
12/4/11	220	NA	NA	Sparge at 02:00. We ran out of H2 in the cylinders around 11:00. Sparge at 14:00 but we got a Sparge timeout alarm at 15:48 because the sparge process was stuck in the very last step because since there was no H2, the NOx numbers couldn't get below 0.6mg/L to complete the sparge cycle.

Date	Day	Operator	Lead Reactor	Notes
12/5/11	221	DB	NA	No sampling today due to running out of H2 over the weekend. Cameron Welding to deliver new 6 pack later today. Currently only running on one cylinder (400 psi). CDM to coordinate w/APT to see if Rich Buday will be on site later today and switch out regulator to new 6 pack. Cameron to deliver another 6 pack on 12/7/11. There was a sizable leak that occurred on the N2 sparge line just prior to the second valves. CDM tightened it up and minimized leak but required further maintenance and possible repair (CDM alerted APT). Cameron to fill N2 dewar today as the leak likely caused us to run out of N2. CDM closed off valve on N2 dewar to prevent further loss on gas upon filling up the dewar today (~12pm). N2 line pressure low alarm at 00:27. H2 back at around 09:30 (from one cylinder). Rich was onsite: H2 generator restarted at 13:10. Fixed N2 leak. Sparge at 14:00. H2 generator shut down at 16:39. At 18:24, R1&R2 H2 P were changed from 16.5 to 8.25psig so we don't run out of H2 from the one H2 cylinder left until it gets fixed next morning.
12/6/11	222	NA	NA	Reactors swapped positions at 12am (R1 is in the lead). Sparge at 02:00. Rich onsite: Restarted H2 generator and put R1&R2 H2 pressures back to 16.5psig (their original values) at 08:38. Filter B (the one on the right) was turned off at 08:45. At 10:06 filter A (the one on the left) started. Filter A backwash at 10:12. Sparge at 14:00. Rich onsite: Around 16:00, Rich calibrated the pH, ORP probes. Also, to see how quickly turbidity recovers, he dosed 13g/L of filter aid (SWT2000) at 35ml/min for 5 min and turbidity dropped significantly from ~0.9 to 0.17NTU. Manual Filter A backwash at 19:52.
12/7/11	223	NA	NA	No sampling today. Plant is not yet at steady state. Filter aid not yet implemented. Sparge at 02:00. Rich onsite: Filter aid (SWT2500, 13g/L at 7ml/min) from 11:52 to 13:45. Turbidity dropped from 0.55 to 0.12NTU. Filter aid was delivered to the wrong location. Manual Sparge at 13:35.
12/8/11	224	NA	NA	Sparge at 01:00. Rich was onsite: At 11:00, he secured all fiberglass heads using wood screws. At 12:30, he cleaned recirc flow meters. Sparge at 13:22.
12/9/11	225	CA	MBfR1	No sampling today as filter aid was not delivered to the proper address. Filter aid to arrive at CDM Rancho Office on 12/12/11. CDM onsite to take weekly compliance samples. Sparge 01:00. Sparge 13:00. CDM collected weekly compliance samples only.
12/10/11	226	NA	NA	Reactors swapped positions at 12am (R2 is in the lead). Sparge 01:00. Sparge 13:00.
12/11/11	227	NA	NA	Sparge 01:00. Sparge 13:00.

Date	Day	Operator	Lead Reactor	Notes
12/12/11	228	NA	NA	No sampling today. Filter aid delivered to CDM office this morning. APT picked it up and filled filter aid tank so system can officially be set at steady state conditions. Sparge 01:00. Sump pump discharge pressure dropped significantly from 30 to 5 psig at 11:13. Sparge 13:00. Rich was onsite around 15:00:Filter aid started (26g/L at 4ml/min). Leak in the convex trailer. The secondary containment switch triggered an automatic shut down of influent well water but the MBfR system kept running. The cause of the leak was a hose connection coming lose from the charlock fitting at the influent of the lead GAC vessel. Some quantity of water was discharged to soil surrounding the southern conex box secondary containment area. Rich fixed the leak. System was shut down at 16:36 while Daniel and Clyde processed the water from secondary containment to the sump tank. Collected water sample and soil sample for perchlorate analysis. Soil sample collected from impacted area.
12/13/11	229	NA	NA	System restarted at 11:20. Sparge at 13:00.
12/14/11	230	NA	NA	CDM onsite. Pumped remaining standing water in secondary containment into the sump tank. The turbidity meter was unplugged from 10 - 11 am so that the power strip could be used to pump water out from secondary containment. CDM installed hose clamps on GAC vessel and IX vessel connections that did not have them. Turbidity samples were not collected due to a sparge initiation prior to sampling. CDM checked level and height of the secondary containment switch: it engages at approximately 5 to 6 inches. The sump pump pressure was 31 psi. The lead GAC vessel had a high differential pressure (20 psi). Reactors swapped positions at 12am (R1 is in the lead). Sparge at 01:00. Steady state started today. Sparge at 13:00.
12/15/11	231	NA	NA	Sparge at 01:00. Sparge at 13:00. CDM on site to bypass GAC-1 (lead vessel) and re hose GAC-2 as the only inline GAC vessel. GAC-1 was isolated from the system. Collected pressure readings prior to removal of the GAC-1 vessel.
12/16/11	232	NA	NA	CDM onsite. Weather is very windy but the canopy is holding in place. APT and Sterling Water onsite to troubleshoot filter aid. The reading was 0.55 NTU on the turbidimeter. CDM contacted Cameron Welding to refill the CO2 dewar and backup cylinders. CDM inspected and replaced the bag filters. A 200/100 micron filter was installed. The heel drain pump on R2 was accidentally left in the afternoon; the valve was opened and then closed but did not actuate. This resulted in the lag vessel completely draining to the reject tank over a period of about 15-20 minutes and having to be refilled at 1:30. Sparge at 01:00. Rich and Kevin onsite: Due to a low MBfR flow rate (6gpm) we are generating sulfides which we believe is the cause of higher turbidity. They were trying to figure out what the correct type and concentration of filter aid is to remove sulfide. Working doing jar test to optimize turbidity. Sparge at 15:32.
12/17/11	233	NA	NA	Sparge at 03:00. Sparge at 15:00.

Date	Day	Operator	Lead Reactor	Notes
12/18/11	234	NA	NA	Reactors swapped positions at 12am (R2 is in the lead). Sparge at 03:00. Sparge at 15:00.
12/19/11	235	NA	NA	Cameron Welding onsite to replace CO2 dewar. CDM onsite to collect weekly samples and field duplicates. CDM adjusted/postponed the sparge. It will be reset after sampling is complete. Outlet totalizer is gunked up and the head has moss growing inside it. The unit needs servicing. Sparge at 03:00. R1 Sample valve left closed around 13:30. Sparge at 16:00. Rich onsite: Jar testing with ferric chloride. At 19:25, turned pump down from 7 to 2ml/min. At 21:00, initiated manual backwash. After turbidity recovered, it dropped to ~0.25NTU.
12/20/11	236	NA	NA	Sparge at 03:00. Rich onsite: Increased filter aid pump from 2 to 3ml/min around 11:45. Increased filter aid pump from 3 to 4ml/min around 12:30. Opened R1 sample valve to Nit. Analyzer around 12:30. Increased filter aid pump from 4 to 5ml/min around 13:00. Rich calibrated pH and ORP probes from 12:50-13:40. Sparge at 15:00.
12/21/11	237	NA	NA	Hydrogen sulfide odor was not strong today, even when removing the aeration lid, the smell dissipated quickly. Lag/aeration sulfide levels were lower than on Monday. APT onsite to top off filter aid. Sparge at 03:00. Rich initiated manual backwash at 10:50 and change dP set point to 7.5. Sparge at 15:00.
12/22/11	238	NA	NA	Reactors swapped positions at 12am (R1 is in the lead). Sparge at 03:00. Sparge at 15:00.
12/23/11	239	DB	MBfR1	Media filter triggered a backwash just prior to site arrival. CDM unable to collect a media filter backwash sample. APT on site to top off the coagulant tank and lower coagulant flow rate from 6 to 4 ml/min. Chlorine residual on product water was high so the tank was topped off with media filter effluent water (no sodium hypo was added). The target residual is 0.2 mg/L at a flow of 5 gpm and the measured residual was 1 mg/L. Sparge at 03:00. Filter backwash at 09:07. Sparge at 15:00.
12/24/11	240	NA	NA	Sparge at 03:00. Sparge at 15:00.
12/25/11	241	NA	NA	Filter backwash at 00:30. Sparge at 03:00. Sparge at 15:00.
12/26/11	242	NA	NA	Reactors swapped positions at 12am (R2 is in the lead). Sparge at 03:00. Sparge at 15:00. Filter backwash at 20:06.
12/27/11	243	DB	MBfR2	APT lowered the coagulant tank flow rate from 4 ml/min to 3 ml/min. The sump pump is making an audible whining noise. Air quality monitoring shows no hydrogen sulfide near the aeration tank or inside the tank. The meter was allowed to collect continuous data over a duration of 1.5 hours. Sparge at 03:00. Sparge at 15:00.
12/28/11	244	DB	MBfR2	The inline turbidimeter was reading 2.2 NTU. There was a negative differential pressure on the media filter. CDM notified APT and Rich Buday came to do maintenance. The chlorine residual at the finished water was high (1 mg/L) so media filter effluent water was used to fill the rest of the tank and dilute the dose. APT fixed the high turbidity readings - the discrepancy was due to no flow going through the meter. Turbidity stabilized at 0.09 NTU. Sparge at 03:00. Filter backwash at 07:25 (dP to trigger backwash had been changed to 5psi). Sparge at 15:00.

Date	Day	Operator	Lead Reactor	Notes
12/29/11	245	NA	NA	CDM onsite for sampling and monitoring. Air quality monitoring showed no hydrogen sulfide near the aeration tank or inside the tank. Sulfide odor was not noticeable. APT installed a new level switch for the secondary containment in the south conex trailer that triggers if approximately 4 inches of standing water are present and shuts down the MBfR treatment system. Sparge at 03:00. Rich installed the additional float switch. Filter backwash around 12:00. Sparge at 15:00.
12/30/11	246	CA	MBfR1	CDM reduced CO2 feed pressure from 106 to 89 psi. CDM will also be conducting air sampling. Increased sodium hypo pump rate to 40 spm and 100 percent stroke length to increase chlorine dose. Changed out bag filter. Determined that GAC-2 pressure gauge is not functioning properly. A replacement gauge should be ordered. Sparge was manually initiated at 12:10. Phosphate concentration after increasing tank level reading was 1.4 ppm-PO4. Reactors swapped positions at 12am (R1 is in the lead). Sparge at 03:00. Sparge at 12:10. Filter backwash at 17:28.
12/31/11	247	NA	NA	Sparge at 00:00. Sparge at 12:00. Filter backwash at 21:23.
1/1/12	248	NA	NA	Sparge at 00:00. Sparge at 12:00.
1/2/12	249	NA	NA	Sparge at 00:00. Filter backwash at 04:11. Sparge at 12:00.
1/3/12	250	CA	MBfR2	CDM changed GAC-2 pressure gauge. Conducted air monitoring. Chlorine residual was 0 ppm at the finished water; after increasing tank level reading was 1.5 mg/L at the media filter effluent. Media filter backwash trigger is 5 psi differential pressure. Reactors swapped positions at 12am (R2 is in the lead). Sparge at 00:00. Filter backwash at 07:37. Sparge at 15:50. We lost feed flow because the well was off due to containment alarm being engaged. One of the CDM-installed switches had a false-trip (it was from a very high wind that blew the secondary containment level switch). System back up and running at around 19:20
1/4/12	251	DB	MBfR2	APT on site to switch out camera security system. CDM noticed low pH on MBfR2 and alerted APT. The meter was not receiving flow. Upon reinstating flow, the pH stabilized at 7.1. The chlorine residual was 2 ppm at the finished water, so at 10:00 am, the sodium hypo dosing pump flow rate was decreased to 20 spm from 30 spm (from 5.9 to 4.3 ml/min) and the tank was topped using media filter effluent water to dilute the dosing. After 1 hour the chlorine residual was 1.1 ppm at the media filter effluent and after 2 hours was 1.1 ppm at the finished water. CDM switched the GAC-2 pressure gauge because the range was not sensitive. No air monitoring collected today as the instrument is in the office for data download. System automatically shut down when secondary containment level switch was accidentally triggered by high winds. This shut down the influent well and the influent tank went dry. System was down for approximately 0.5 hours. Sparge at 03:00. System down due to a High Level on R2 (the reactor level instrument was lagging the actual level and it filled at 30-35gpm versus the 6gpm the overflow manual valve is throttled to manage). System back up and running at around 7:30. Filter backwash at 12:08. Sparge at 15:00. System down due to a High Level on R2. System back up and running at around 22:45.

Date	Day	Operator	Lead Reactor	Notes
1/5/12	252	NA	MBfR2	System was shut down intermittently due to high level switch on MBfR triggering while refilling. System was down for 0.5 to 1 hour. Sparge at 03:00. System down due to a High Level on R2. System back and running at around 6:40. Sparge at 15:00. Filter backwash at 23:02.
1/6/12	253	DB	MBfR2	The chlorine residual was 1.2 ppm at the finished water (target was 0.2 ppm). Lowered the chlorine dosing pump to 17 spm at 10:40 am. After two hours the finished water still read above 1 ppm so the tank was topped off using media filter effluent water and the pump was lowered to 15 spm (3.3 ml/min). Sparge at 03:00. Sparge at 15:00.
1/7/12	254	NA	NA	Reactors swapped positions at 12am (R1 is in the lead). Filter backwash at 00:54. Sparge at 03:00. Sparge at 15:00.
1/8/12	255	NA	NA	Sparge at 03:00. Filter backwash at 13:54. Sparge at 15:00.
1/9/12	256	CA	MBfR1	Windy today. CDM performed air monitoring today. Weekly and duplicate samples were collected. Air monitoring has shown very little H2S. CO has had some readings as high as 35 ppm, but interference from hydrogen could be inflating readings. HAAs bottles received at the lab for finished water only. Sparge at 03:00. Sparge at 15:00. Filter backwash at 18:37.
1/10/12	257	NA	NA	Sparge at 03:00. Sparge at 15:00.
1/11/12	258	DB	MBfR2	Final day of steady state monitoring. Sparge sample was collected, but media filter backwash sample was not collected. The differential pressure was only 0.4 psi as it was backwashed last night. APT on site to clean and calibrate the pH and ORP probes, clean nitrogen analyzer. Collected 4 side- reactors and shipped to ASU. Reactors swapped positions at 12am (R2 is in the lead). Filter backwash at 02:06. Sparge at 03:00. Sparge at 11:56. Four remaining lab reactors were harvested and shipped to ASU.
1/12/12	259	DB	MBfR2	First day of Challenge testing, Test 1. Turned off hydrogen and CO2 at 4 am and turned them back on at 8 am. Took pH readings on lead and lag at 08:15 because online readings were low. Lead sample - 7.07 SU online - 6.8 SU; Lag sample - 7.12 SU online 6.6 SU. Temperature was 19.3 and 20.3 deg C at the lead and lag, respectively. The lag sample at 10:15 was 7.81 and online reading was 7.2 SU. Collected media filter backwash sample at 10:12. Sparge at 03:00. Filter backwash 10:10.
1/13/12	260	CA	MBfR2	CDM collected sample at 12:30. Nitrate and nitrite holding times were exceeded for Duplicate 1 and Finished water samples. Sparge at 03:00. Filter backwash at 16:40.
1/14/12	261	NA	NA	Sparge at 03:00.
1/15/12	262	NA	NA	Reactors swapped positions at 12am (R1 is in the lead). Sparge at 03:00. Filter backwash at 06:42. Test 2 of the Challenge Phase: Hydrogen shutoff for 24 hours Shut off hydrogen and CO2 from 8am to 8am the next day). Sparge at 22:07.

Date	Day	Operator	Lead Reactor	Notes
1/16/12	263	CA	MBfR1	Test 2 initiated on 1/15 at 8:00; hydrogen, nitrogen, and carbon dioxide were shut off for 24 hours. First sample collected after reactor was restarted at 8:32. CDM Smith collected samples for testing as well as at the media filter effluent and duplicate samples. Filter aid is empty, APT was contacted for a refill. Sparge at 09:06.
1/17/12	264	CA		CDM Smith changed the backwash differential trigger level today to 10 psi to delay backwash for sampling. Changed back to 5 psi after sampling was completed. A media filter backwash was initiated at 13:08. Collected weekly permit compliance samples from the outfall and GAC effluent for VOCs at 12:00. Sparge at 16:57.
1/18/12	265	DB	MBfR1	APT forgot to start the filter aid pump so the pump was restarted by CDM Smith upon arrival at the site. After the filter aid was turned on, the online turbidity went from 0.46 NTU to 0.09 NTU. Collected weekly permit compliance sample from the outfall for perchlorate at 13:00. Sparge at 04:00. Filter backwash at 07:26. Sparge at
1/19/12	266	DB	MBfR2	Test 3 initiated at 4 am, shut off entire system. At 8 am CDM Smith on site, found leak from lag side-reactor to outside of secondary containment. The leak from secondary containment that started in the middle of the night. One of the tubes that fed the lag side reactor was routed to discharge into the reactor using a zip-tie. The zip-tie came loose and water was discharged out of secondary containment. Received approval from RWQCB, restarted system around 09:00. R2 (lag) was 10 to 20% full, R1 (lead) was 5% empty. MBfR reactors switched positions upon restart so R2 was in lead - this would allow it to fill up first. First sample for Test 3 collected at 09:57, had to refill MBfR, media filter, product tank etc.. prior to collecting sample. CDM Smith collected a sample from impacted soil and puddled water on the ground. Sample was collected from finished water at 13:57, then a daily sparge sequence initiated at 14:00. However, APT caught the sparge in time to stop the process. The lag reactor did drain down. APT restarted normal operation and filled reactors back up. Duplicate samples were collected. Reactors swapped positions at 12am (R2 is in the lead). Sparge at 02:00. Turbidity analyzer taken offline at 12:37. Sparge at 20:34. Filter backwash at 23:42.
1/20/12	267	DB	MBfR2	Filter aid tank was empty upon arrival so CDM Smith turned off the dosing pump upon arrival. Sparge at 08:00. Sparge at 20:00.
1/21/12	268	NA	NA	Sparge at 08:00. Sparge at 20:00.
1/22/12	269	NA	NA	Sparge at 08:00. Sparge at 20:00.
1/23/12	270	CA		Test 4 initiated at 09:44, entire system was shut down. Duplicate samples collected from the influent and outfall for VOCs. Monthly permit compliance samples collected at 09:00. Reactors swapped positions at 12am (R1 is in the lead). Filter backwash at 03:10. Sparge at 08:00.
1/24/12	271	CA		System restarted at 09:45. Samples and duplicates were collected. Sparge at 20:00. Manual filter A backwash at 22:56.

Date	Day	Operator	Lead Reactor	Notes
1/25/12	272	CA		<p>Last day for system monitoring. Sparge at 08:00. Samples were collected at 09:15. APT shut down the system at 09:58 and CDM Smith disconnected the gas cylinders. At 10:15 the system was restarted at 20 gpm for a system flush; at 10:25 flow was reduced to 10 gpm. Both media filters were backwashed at 10:06 (Filter A) and 10:25 (Filter B). There are two hydrogen 6-packs on site, one is empty and the other is partially full. CDM Smith dropped off samples at Test America because currier was not present for pick up (they forgot). Chlorine residual at the media filter effluent was 0.2 mg/L but the finished water was 0 mg/L.</p> <p>Feed flow changed to 5gpm around 11:45 and then to 10gpm around 12:30. Manual filter B backwash at 16:11. Shut entire system off at 17:00.</p>

SYSTEM MONITORING DATA

Manual Data Collection																	
Date and Time	Inlet Totalizer	Outlet Totalizer	Target Flow Rate	Media Filter Flow Rate	R1 Internal Recycle Rate	R2 Internal Recycle Rate	MBfR 1 pH	MBfR 2 pH	MBfR 1 ORP	MBfR 2 ORP	R1 Sparge Rate	R2 Sparge Rate	Last N Feed	Last N (R1)	Last N (R2)	Air Flow	Air Tank Press
	gal	gal	gpm	gpm	gpm	gpm	std units	std units	mV	mV	mm	mm	ppm (N)	mg/L-N	mg/L-N	scfm	psig
4/20/11 18:00		3791700	-				-	-	-	-			-	-	-	-	-
4/22/11 8:00		-	-				5.8	7.8	-	-			-	-	-	-	-
4/25/11 10:00		-	-				8.5	7.6	-	-			-	-	-	-	-
4/28/11 18:40		3799700	-				-	-	-	-			-	-	-	-	-
4/29/11 11:00		-	5						-	-			-	-	-	-	-
5/2/11 9:00		3825300	5				7.5	7.5	-	-			-	-	-	-	-
5/4/11 9:30		3837600	5				6.7	7.5	-	-			-	-	-	1.8	3.6
5/6/11 9:00		3847400	5				6.4	7.5	-	-			-	-	-	1.7	3.7
5/9/11 10:00		3867600	5				7.6	7.5	-	-			8.73	0.43	0.43	1.8	3.5
5/11/11 11:00		3880500	5				6.4	7.5	-	-			3.33			1.7	3.5
5/13/11 9:00		3896800	8				7.5	7.6	-557	67			8.76	0.07	6.42	1.7	3.7
5/16/11 9:30		3933800	10				7.2	7.2	-53	-655			8.45	6.14	3.26	1.7	3.6
5/18/11 9:00		3960400	10				7.2	7.2	-23	-642			8.29	6.31	3.66	1.6	3.6
5/20/11 8:30		3987200	10				7.5	7.5	-685	-565			8.23	3.44	4.49	1.6	3.6
5/23/11 0:00		4021400	8				7.2	7.2	-239	-590			8.37	5.13	1.49	1.6	3.5
5/25/11 9:00		4044400	8				7.2	7.2	-103	-590			-			1.7	3.5
5/27/11 10:00		4064700	8				7.2	7.2	-558	-272			8.4	0.07	6.2	1.6	3.6
6/1/11 12:00		4120700	10				7.2	7.2	5	-691			8.34	6.3	2.23	1.6	3.6
6/3/11 9:00		4141000	10				7.2	7.2	-59	-700			8.31	5.01	0.98	1.6	3.6
6/6/11 8:30		4193300	12	11.5			7.2	7.2	-512	-302			8.33	1.85	6.48	1.7	3.6
6/10/11 9:30		4253100	12	11.5			7.2	7.2	-252	-662	41	40	7.79	4.84	1.06	1.7	3.6
6/13/11 9:30		4301300	12	11.5			7.2	7.2	-611	-228	39	41	7.81	-1.5	-1.5	1.6	3.5
6/15/11 10:00	534393	4333400	12	11.5			7.2	7.2	-611	-188			8.26	0.79	6.12	1.7	3.8
6/16/11 8:30	549338	4348200	12	11.5			7.2	7.2	-303	-663			7.95	5.42	0.69	1.7	3.8
6/20/11 13:10	614854	4414200	12	11.5			7.2	7.2	-613	-162	38	42	7.81	0.06	4.84	1.8	3.9
6/22/11 10:00			12	11.5													
6/27/11 7:30			12	11.5			7.2	7.2	-65	-570			9.1	5.49	0.06	1.7	4
7/1/11 0:00			12														
7/5/2011 7:45	869289	4664100	16	16			7.2	7.2	8	-261	210	210	8.13	6.36	0.68	1.7	3.9
7/7/11 0:00			16														
7/11/11 8:30		4774800	16	bypass			7.2	7.2	153	-565	210	210	7.82	6.09	0.08	1.5	3.9
7/18/11 8:00	1123560	4925400	10														
7/25/11 8:30	1286360	5086600	20	15			7.21	7.2	-387	-65	210	210	8.07	0.44	2.06	1.6	4
7/29/11 8:00			20														
8/1/11 9:45		5277200	22	18			7.2	7.2	-548	-544	210	210	7.7	6.21	1.92	1.6	3.9
8/2/11 11:15			22														
8/5/11 9:00			21														

Manual Data Collection																	
Date and Time	Inlet Totalizer	Outlet Totalizer	Target Flow Rate	Media Filter Flow Rate	R1 Internal Recycle Rate	R2 Internal Recycle Rate	MBfR 1 pH	MBfR 2 pH	MBfR 1 ORP	MBfR 2 ORP	R1 Sparge Rate	R2 Sparge Rate	Last N Feed	Last N (R1)	Last N (R2)	Air Flow	Air Tank Press
	gal	gal	gpm	gpm	gpm	gpm	std units	std units	mV	mV	mm	mm	ppm (N)	mg/L-N	mg/L-N	scfm	psig
8/8/11 8:30		5459700	20	18			7.2	7.2	-564	210	210	210	7.57	0.1	3.62	1.7	3.9
8/15/11 7:45		5629100	18	18			7.2	7.2	-585	-46	280	280	6.61	0.07	2.49	1.6	3.9
8/17/11 8:30		5680800	18	16			7.2	7.2	-587	-43	280	280	3.76	0.23	2.92	1.6	4
8/19/11 9:00		5731200	18	16			7.2	7.2	-378	-537	280	280	2.93	2.8	0.31	1.6	3.9
8/26/11 8:20		5812300	15	14			7.2	7.2	-340	-91	280	280	3.08	0.13	2.17	0.5	5.3
8/29/11 12:15		5869600	15	14			7.2	7.2	-7	-350	280	280	2.25	3.52	3.4	3.3	2.2
8/31/11 9:00		5899900	15	14			7.2	7.2	-348	-105	280	280	7.82	0.19	1.65	3.3	2.2
9/2/11 13:30		5942400	15	14			7.2	7.2	-331	-51	280	280	7.78	0.25	2.72	3.2	2.2
9/7/11 13:45		6048200	15	14			7.2	7.2	102	-472	280	280	7.71	3.82	0.66	3.2	2.2
9/9/11 10:00		6078500	10	9			7.2	7.2	-288	-50	280	280	7.93	0.33	2.18	3.3	2.2
9/12/11 13:30		6121600	10	9			7.2	7.2	-272	-452	280	280	7.93	1.2	0.91	3.3	2.2
9/14/11 10:30		6150600	10	9	280	280	7.2	7.2	-81	-324	280	280	7.95	2.26	0.47	3.2	2.2
9/16/11 9:00		6184300	20	9	280	280	7.2	7.2	-247	-81	280	280	7.78	0.8	3.63	3.2	2.2
9/19/11 9:15		6209200	5	4.5	280	280	--	7.2	--	-221	280	280	7.98	--	0.31	3.3	2.1
10/3/11 7:00		6389700	10	9	180	180	7.2	7.2	-614	-65	240	240	7.98	0.03	2.64	3.4	2.1
10/5/11 8:30		6418800	10	9	180	180	7.2	7.2	-630	-90	240	240	7.99	0	2.24	3.2	2
10/7/11 9:00		6446800	10	9	180	180	7.2	7.2	-224	-422	240	240	8.03	1.81	0	3.2	2.1
10/10/11 9:15		6470800	5	4.5	180	180	7.1	7.2	-638	-655	240	240	8.13	1.56	0.03	3.4	2
10/12/11 9:00		6484400	5	4.5	180	180	7.2	7.2	-438	-245	240	240	8.2	0.52	0.15	3.3	2.2
10/14/11 9:00		6498800	5	4.5	180	180	7.2	7.2	-440	-240	240	240	8.17	1.26	0.05	3.4	2
10/17/11 9:00		6539000	10	4	150	180	7.2	7.2	-393	-22	240	240	8.08	0.26	5.5	3.2	2.2
10/19/11 9:00		6567400	10	9	180	180	7.2	7.2	-395	-47	200	240	8.08	0.02	3.07	3.2	2
10/21/11 9:00		6596100	10	9	180	180	7.2	7.2	-444	23	240	240	8.09	0.23	6.17	3.2	2
10/26/11 8:45		6666600	10	9.5	180	180	7.2	7.2	-410	-208	240	240	8.1	0.16	2.63	3.2	2
10/28/11 9:00		6688500	10	9	150	180	7.2	7.2	-465	-134	240	240	8.11	0.23	4.29	3.2	2
10/31/11 9:30		6728000	10	9	150	180	7.2	7.2	-413	-243	240	240	8.13	0.12	2.77	3.2	2
11/2/11 9:00		6756700	10	9.5	150	180	7.2	7.2	-392	-377	240	240	8.15	0.4	0.81	3.2	2.1
11/4/11 8:00		6785300	10	9	150	180	7.2	7.2	-404	-398	240	240	8.1	0.28	0.95	3.1	2
11/7/11 9:30		6827900	10	9	150	180	7.2	7.2	-390	-427	240	240	8.1	0.21	0.92	3.2	2
11/9/11 8:45		6855100	10	9	150	180	7.2	7.2	-601	-534	240	240	8.12	0.23	0.86	3.2	2
11/11/11 8:30		6883900	10	9	150	180	7.2	7.2	-606	-542	240	240	8.14	0.28	0.89	3.2	2
11/14/11 8:00		-	10	9	100	150	7.2	7.2	-611	-499	240	40	8.1	0.16	1.75	3.2	2.1
11/16/11 8:00		6944900	10	9	150	180	7.2	7.2	-580	-434	240	70	8.12	0.12	1.6	3.2	2.1
11/18/11 9:00		6972300	10	9	150	180	7.2	7.2	-472	-440	240	240	8.15	0	1.35	3.2	2
11/22/11 10:30		7019400	10	9	150	180	7.2	7.2	-469	-324	240	240	8.12	0.04	2.35	3.2	2
11/28/11 9:30		7088100	8	7	120	150	7.2	7.2	-514	-387	240	240	8.22	0.04	2.28	3.2	2
11/30/11 10:00		7108600	8	6	150	180	7.2	7.2	-309	-719	240	240	8.24	1.73	0	3.2	2

Manual Data Collection																	
Date and Time	Inlet Totalizer	Outlet Totalizer	Target Flow Rate	Media Filter Flow Rate	R1 Internal Recycle Rate	R2 Internal Recycle Rate	MBfR 1 pH	MBfR 2 pH	MBfR 1 ORP	MBfR 2 ORP	R1 Sparge Rate	R2 Sparge Rate	Last N Feed	Last N (R1)	Last N (R2)	Air Flow	Air Tank Press
	gal	gal	gpm	gpm	gpm	gpm	std units	std units	mV	mV	mm	mm	ppm (N)	mg/L-N	mg/L-N	scfm	psig
12/2/11 1:00			6	5													
12/5/11 8:40		7153300	6	5													
12/9/11 12:00		7189400	6	5	120	150	7.2	7.2	-332	-698	240	240	8.25	1.3	0.18	3.2	2
12/14/11 9:30		7226000	6	5	120	150	7.2	7.2	-292	-661	240	240	8.03	1.62	0.24	3.2	2
12/16/11 9:00		7244100	6	3	120	150	7.2	7.2	-293	-704	240	240	8.03	1.62	0.08	3.2	2
12/19/11 10:30			6	5	120	150	7.2	7.2	-487	-1000	240	240	8.31	0.42	0.165	3.2	2
12/21/11 8:00		7285800	6	5	120	150	7.2	7.2	-465	-389	240	240	8.29	0.04	1.77	3.1	2
12/23/11 9:30		7304000	6	5	120	150	7.2	7.2	-267	-621	240	240	8.32	1.58	0.13	3.2	2
12/27/11 8:45		7339400	6	5	120	150	7.2	7.2	-446	-865	240	240	8.32	0.06	1.68	3.2	2
12/28/11 9:00		7348300	6	5	120	150	7.2	7.2	-442	-951	240	240	8.33	0.1	1.53	3.1	2
12/30/11 9:00		7366900	6	5	120	150	7.2	7.2	-245	-641	240	240	8.3	1.38	0.64	3.2	2
1/3/12 10:00		7405200	6	5	120	150	7.2	7.2	-452	-901	240	240	8.38	0.35	1.5	3.2	2
1/4/12 9:30		7409800	6	5	120	150	7.2	7.2	-245	-838	240	240	8.38	0.57	1.33	3.2	2
1/6/12 9:30		7425000	6	5	120	150	7.2	7.2	-408	-323	240	240	8.38	0	1.56	3.1	2.2
1/9/12 9:00		7451400	6	5	120	150	7.2	7.2	-247	-688	240	240	8.4	1.41	0.07	3.2	2.1
1/11/12 9:15		7468600	6	5	120	150	7.2	7.2	-476	-193	240	240	8.39	0.06	3.08	3	2.1
1/12/12 8:30		7477200	6	5	90	150	6.6	6.8	-189	-37	240	240	8.36	5.36	7.49	3.1	2
1/13/12 12:00		7487400	6	5	120	150	7.2	7.2	-410	-315	240	240	8.36	0.04	2.21	3.2	2.1
1/16/12 8:20		7513600	6	5	90	150	6.5	6.4	-46	-22	240	240	8.3	8.2	7.93	3.2	2.1
1/17/12 11:30		7521200	6	5	90	150	7.9	7.2	-217	-640	240	240	8.33	1.67	0.02	3.2	2.1
1/18/12 12:45		7530200	6	5	90	150	7.2	7.2	-290	-628	240	240	8.34	1.28	0.11	3.1	2
1/19/12 8:00		7535700	6	5	90	150	7.2	7.2	-563	-189	240	240	8.35	0.06	3.33	3.2	2.1
1/20/12 12:30		7545600	6	5	90	150	7.2	7.2	-455	-230	240	240	8.36	0	2.76	3.1	2
1/23/12 9:00		system monitoring data not collected to shut down system for Test 4 as early as possible															
1/25/12 9:15		7579400	6	5	90	150	7.1	7.2	-201	-483	240	240	8.39	0.84	0.45	3.2	2

Manual Data Collection							
Date and Time	Initial NaOCl Tank Level	Desired NaOCl Feed Rate	NaOCl Stock Added	Volume Water Added	Final NaOCl Tank Level	NaOCl Concentration in Tank	NaOCl Dose
	gal	ml/min	gal	gal	gal	mg/L-Cl	mg/L-Cl
5/2/11 9:00	0						
5/4/11 9:30	0						
5/6/11 9:00	0						
5/9/11 10:00	12.5						
5/11/11 11:00	12.5						
5/13/11 9:00	12.5						
5/16/11 9:30	12						
5/18/11 9:00	11.5						
5/20/11 8:30	10.5						
5/23/11 0:00	10.5						
5/25/11 9:00	9						
5/27/11 10:00	9						
6/1/11 12:00	7.5						
6/3/11 9:00	18						
6/6/11 8:30	15.5						
6/10/11 9:30	6						
6/13/11 9:30	10						
6/15/11 10:00	0		0				
6/16/11 8:30	0		0		0		
6/20/11 13:10	0	5.9	16	14	30	31,810	4.31
6/27/11 7:30	15	5.9	0	15	30	15,905	2.16
7/5/2011 8:00	16	5.9	6	2.3	30	20,406	2.71
7/11/2011 9:00	tank off	tank off	tank off	tank off	tank off	tank off	tank off
7/18/2011 13:00	tank off	tank off	tank off	tank off	28	tank off	tank off
7/25/2011 11:00	14	5.9	0	0	14	20,406	2.12
7/29/2011 10:00	12.5	5.9	0	0	12.5	20,406	2.12
8/1/2011 16:30	9	5.9	14	6	29	35,129	3.04
8/8/2011 9:45	19	5.9	0	0	19	35,129	3.04
8/15/2011 8:00	12	5.9	6	12	30	25,975	2.25
8/17/2011 9:15	27	5.9	0	0	27	25,975	2.25
8/19/2011 13:00	25	5.9	0	0	25	25,975	2.25
8/26/2011 14:00	16	5.9	0	0	16	25,975	2.25
8/29/2011 12:15	9	5.9	5.5	15.5	30	18,823	2.1
9/2/2011 10:00	25	5.9	0	0	25	18,823	2.1
9/7/2011 10:30	15	5.9	0	0	15	18,823	2.1
9/9/2011 14:30	11	5.9	2.5	16.5	30	12,154	2.11
9/12/2011 13:30	25	7.5	0	0	27	12,154	2.7

Manual Data Collection							
Date and Time	Initial NaOCl Tank Level	Desired NaOCl Feed Rate	NaOCl Stock Added	Volume Water Added	Final NaOCl Tank Level	NaOCl Concentration in Tank	NaOCl Dose
	gal	ml/min	gal	gal	gal	mg/L-Cl	mg/L-Cl
9/14/2011						12,154	2.7
9/16/2011 14:45	12	7.5	3	15	30	10,902	4.8
9/19/2011 11:00	22	4.3	0	0	22	10,902	2.8
10/7/2011 3:00	6	7.5	8	16	30	18,149	4.00
10/12/2011 1:00	20				20	18,149	4.00
10/14/2011 12:15	18				18	18,149	4.00
10/17/2011 2:00	8	5.9	7	15	30	18,759	3.25
10/19/2011 9:30	25				25	18,759	3.25
10/21/2011 10:30	20		0	0	20	18,759	3.25
10/26/2011 9:00	7		0	0	7	18,759	3.25
10/28/2011 11:30	2	7.5	7	21	30	15,170	3.34
10/31/2011 9:00	30				30	15,170	3.34
11/2/2011 9:00	22	7.5	0	0	22	15,170	3.34
11/4/2011 11:30	20	7.5	0	0	20	15,170	3.34
11/7/2011 9:30	14	7.5	0	0	14	15,170	3.34
11/9/2011 8:45	7	7.5	0	0	7	15,170	3.34
11/11/2011 8:30	5	7.5	6	19	30	14,452	3.18
11/14/2011 8:00	25	7.5	0	0	25	14,452	3.18
11/16/2011 8:00	-	-	-	-	-	14,452	3.18
11/18/2011 9:30	15	-	-	-	15	14,452	3.18
11/22/2011 10:30	9	5.9	5	16	30	14,513	3.23
11/28/2011 1:05	-	-	-	-	-	14,513	3.23
11/30/2011 12:00	15	5.9	-	-	15	14,531	3.78
12/2/2011 1:30	12	5.9	1	17	30	7,848	2.45
12/9/2011 12:00	15	5.9	-	-	15	7,848	2.45
12/14/2011 11:30	8	5.9	-	-	8	7,848	2.45
12/16/2011 3:00	4	5.9	3.25	22.75	30	7,661	2.39
12/19/2011 2:15	27	5.9	-	-	27	7,661	2.39
12/21/2011 10:00	25	5.9	-	-	25	7,661	2.39
12/23/2011 10:00	18	5.9	-	12	30	4,597	1.43
12/27/2011 9:30	23	5.9	-	-	23	4,597	1.43
12/29/2011 10:00	21	5.9	-	9	30	3,218	1
12/30/2011 13:15	20	7.5	-	-	20	3,218	1
1/3/2012 14:15	10	5.9	2	18	30	5,143	1.6
1/4/2012 11:00	28	5.9	-	2	30	4,801	1.1
1/6/2012 12:00	28	4.3	-	2	30	4,480	0.78
1/9/2012 13:45	24	3.3	-	-	24	4,480	0.78

Manual Data Collection							
	Initial NaOCl Tank Level	Desired NaOCl Feed Rate	NaOCl Stock Added	Volume Water Added	Final NaOCl Tank Level	NaOCl Concentration in Tank	NaOCl Dose
Date and Time	gal	ml/min	gal	gal	gal	mg/L-Cl	mg/L-Cl
1/11/2012 10:00	24	3.3	-	-	24	4,480	0.78
1/12/12 8:30	-	-	-	-	-	4,480	0.78
1/13/2012 13:15	20	3.3	-	-	20	4,480	0.78
1/16/2012 13:30	18	3.3	-	-	18	4,480	0.78
1/17/2012	17	3.3	-	-	17	4,480	0.78
1/18/12 12:45	-	-	-	-	-	4,480	0.78
1/19/12 8:00	-	-	-	-	-	4,480	0.78
1/20/2012 13:00	15	-	-	-	15	4,480	0.78
1/25/12 9:15	-	-	-	-	-	4,480	0.78

Manual Data Collection																
Date and Time	Initial Phosphate Tank Level gal	Desired Phosphate Feed Rate ml/min	Phosphate Stock Added ml	Volume Water Added gal	Final Phosphate Tank Level gal	Media Filter Inlet Pressure psi	Media Filter Outlet Pressure psi	Bag Filter dP psi	Cylinder Pressure 1 psig	N ₂ Pressure psig	CO ₂ Cylinder Pressure psi	GAC-1 Pressure psi	GAC-2 Pressure psi	IX Pressure psi	Turbidity (on line) NTU	Turbidity (in field) NTU
4/28/11 18:40	5	2	-	-	5			-	-	-						
4/29/11 11:00	-	2	-	-				-	-	-						
5/2/11 9:00	3	2	-	-	3			-	1000	-						
5/4/11 9:30	1.8	2	42.3	3.8	5.6			0	700	175						
5/6/11 9:00	3.5	2	-	-	3.5			0	700	175						
5/9/11 10:00	1.4	2	48.2	3.6	5			0	700	175						
5/11/11 11:00	3.2	2	-	-	3.2			0	700	175						
5/13/11 9:00	2.3	2	36	3.7	6			0	700	175						
5/16/11 9:30	3.4	2	-	-	3.4			0	700	175						
5/18/11 9:00	2.2	2	37.5	2.8	5			0	700	175						
5/20/11 8:30	5	2	-	-	5			0	700	175						
5/23/11 0:00	5	2	-	-	5			0	2200	175						
5/25/11 9:00	4.5	2	-	-	4.5			0	1700	175						
5/27/11 10:00	4.5	2	-	-	4.5			0	1700	175						
5/31/11 12:00	0.3	2	-	-	2.8											
6/1/11 12:00	3.2	2	-	-	3.2			0	1700	175						
6/3/11 9:00	1.1	2	-	-	5			2	1700	-						
6/6/11 8:30	4.7	2	400	5	4.7			5	1700	-						
6/10/11 9:30	1.5	2	450	5	4.9			0	1400	-						
6/13/11 9:30	2.4	2			4.9			0	1400							
6/15/11 10:00	3.7	2	-	-	5			6				11.2				
6/16/11 8:30	4.3	2	63	0.7	5.0			6	1400		800					
6/20/11 13:10	2.2	2	0	0	2.2				1500							
6/22/11 10:00	0.9	2	900	4.5	5.6											
6/27/11 7:30	2.1	2	570	3	5.3		5.00									
7/1/11 9:00	2	2	500	2.5	4.6											
7/5/2011 8:05	2.5	2	800	2.3	5.0											
7/7/11 9:00	3.2	2	0	2.3	5.5	19.00	17.50		1700	160	90					
7/11/11 9:00	2.6	2	130	2.5	5.1	bypass	bypass	3	92	169	34	14	14	3.5		
7/18/2011 13:00	2.3	2	500	2.7	5.1			7								
7/25/2011 9:00	0	2	500	5	5.1	7.6	5.6	2	92	192	82	6	4	2.2		
7/29/2011 9:30	4	2	400	1	5.1				93	168	83					
8/1/2011 17:00	0	2	900	5	5.2	10.7	7.5	2	91	95	63	10	7	2.5		
8/5/2011 9:00	2.7	2	325	2.3	5.1											
8/8/2011 9:30	2.8	2	340	2.2	5.1	10.2	7.5	2	92	169	90	17	16	4		
8/15/2011 8:30	2.9	2	250	2.1	5	11.9	7.5		92	177	89	18	14	6		
8/17/2011 9:15	2	2	520	3	5.1	11.8	6.2	2	91	182	33	16	12	6		

Manual Data Collection																
Date and Time	Initial Phosphate Tank Level	Desired Phosphate Feed Rate	Phosphate Stock Added	Volume Water Added	Final Phosphate Tank Level	Media Filter Inlet Pressure	Media Filter Outlet Pressure	Bag Filter dP	Cylinder Pressure 1	N ₂ Pressure	CO ₂ Cylinder Pressure	GAC-1 Pressure	GAC-2 Pressure	IX Pressure	Turbidity (on line)	Turbidity (in field)
	gal	ml/min	ml	gal	gal	psi	psi	psi	psig	psig	psi	psi	psi	psi	NTU	NTU
8/19/2011 14:00	2	2	520	3	5.1	13.8	6.3	2	90	175	80	16	11	4.2		
8/26/2011 8:30	3.9	2	0	0	3.9	9	5	4	90	172	82	18	14	3.2		
8/29/2011 12:15	2	2	350	3	5.1	10	5.1		60		60					
8/31/2011 9:00	--	2	0	0	--	7.1	5.1	3	91	172	59	16	14	4		
9/2/2011 13:30	2.8	2	250	2.2	5	7.5	5	3	90	175	80	16	11	2.3		
9/7/2011 13:45	1.8	2	150	3.2	5	9.5	5	4	91	175	105	17	12	3		
9/9/2011 14:45	3.5	2	120	1.5	5	5.7	2.1	3	91	175	73	15	14	3		
9/12/11 13:45	3	2	160	2	5	2.6	2.1	4	91	175	72	16	14	3		
9/14/2011						3	2.2	4	90	175	75	16	14	3		
9/16/2011 14:45	2.4	2	160	2.6	5	7.5	2.2	3	90	161	75	14	9	1.1		
9/19/2011 11:00	2.2	2	25	2.8	5	10.9	1.7	3	90	179	70	15	11	1.8		
10/3/2011 7:30	0	2	400	5	5	10.2	1.5	2	91	143	91	16	12	3		
10/5/11 8:30						2.6	1.5	13	90	144	90	10	5	0		
10/7/2011 3:00	2	2	250	3	5	2.3	1.5	2	90	142	90	17	13	2.5		
10/10/2011 9:30	3	2	0	2	5	2.7	1.3	2	91	184	89	16	13	3		
10/12/2011 1:00	4	-	-	-	4	4.4	1.3	2	89	180	89	17.5	14	2		
10/14/2011 2:30	3	2	50	2	5	3.5	1.3	2	90	153	88	14	9.5	1.2		
10/17/2011 1:40	2.7	2	275	2.3	5	8	1.3	2	88	141	87	14	10	1.4		
10/19/2011 9:30	3.5	-	-	-	3.5	1.6	1.5	2	91	149	88	20.5	14	1.5	0.56	0.21
10/21/2011 13:00	2	-	240	3	5	4.7	1.5	2	89	142	87	15	11	1.1	0.51	
10/26/2011 2:00	1.3	2	300	3.7	5	9	1.5	2	88	147	88	15	10.5	1		
10/28/2011 9:00	4	2	-	-	4	3.2	1.6	2	88	137	88	15	10.5	1		
10/31/2011 1:00	2	2	240	3	5	9.3	1.5	2	88	160	88	14	10.5	3.6		
11/2/2011 11:30	3.7	2	0	0	3.7	4.1	1.5		91	153	88				0.2	
11/4/2011 11:30	2.2	2	220	2.8	5	3.5	1.5	2	91	127	88	15	11	1	0.19	0.19
11/7/2011 9:30	3	2	0	0	3	2	1.5	2	88	156	87	14	9	1.4	0.19	0.26
11/9/2011 8:45	1.5	2	280	3.5	5	11	1.5	2	88	155	87	13.6	9	1.4	0.21	0.21
11/11/2011 8:30	3.5	2	0	0	3.5	9.5	1.5		91	147	88				0.22	0.23
11/14/2011 8:00	1.5	2	240	3.5	5	9.8	8.9		91	160	89				0.27	0.27
11/16/2011 9:00	-	-	-	-	-	-	-	-	88	169	91	-	-	-		
11/18/2011 1:00	1.8	2	250	3.2	5	9	7.4	2	88	144	88	6	1	1.3	0.27	0.35
11/22/2011 2:15	1.5	2	275	3.5	5	11.3	1.5	3	91	144	87	15	10	1.5	0.17	0.19
11/28/2011 1:00	0.9	2	250	4	5	9.9	6.5	3	91	157	88	17	14	1.3	0.15	0.29
11/30/2011 12:00	3.5	2	-	-	3.5	2.9	1.3	3	88	168	87	14	10	1.3	0.23	0.4
12/2/2011 1:30	1.8	2	120	3.2	5											
12/5/2011 8:40	2.75	2	100	2.25	5			2								
12/9/2011 12:00	1.5	2	175	3.5	5	2	4.9	2	90		88	14	12	1.5	0.25	0.26

Manual Data Collection																
Date and Time	Initial Phosphate Tank Level	Desired Phosphate Feed Rate	Phosphate Stock Added	Volume Water Added	Final Phosphate Tank Level	Media Filter Inlet Pressure	Media Filter Outlet Pressure	Bag Filter dP	Cylinder Pressure 1	N ₂ Pressure	CO ₂ Cylinder Pressure	GAC-1 Pressure	GAC-2 Pressure	IX Pressure	Turbidity (on line)	Turbidity (in field)
	gal	ml/min	ml	gal	gal	psi	psi	psi	psig	psig	psi	psi	psi	psi	NTU	NTU
12/14/2011 11:30	0.5	2	220	4.5	5	2.5	1.5	4	91	123	88	5	3	1	0.2	0.2
12/15/11 10:00								3				6.5	4.5	1		
12/16/2011 2:45	3.5	2	-	-	3.5	2.9	1.3	4	91	123	70		4	1	0.56	0.57
12/19/2011 2:00	1	2	200	4	5	7.1	1.5	4	8	127	83		5	1	0.63	0.66
12/21/2011 10:00	3.4	2	-	-	3.4	5.4	1.6	2	90	138	95		1	0.3	0.12	0.39
12/23/2011 10:00	2.7	2	300	2.3	5	0	0.4	2	89	143	89		1	0.5	0.43	0.08
12/27/2011 12:30	1.8	2	100	3.2	5	2.9	1.6	2	88	148	110		1	0.8	0.44	0.14
12/28/2011 9:00	4.3	2	-	-	4.3	1.1	1.6	2	90	143	110		0	0.8	0.46	0.09
12/30/2011 13:00	1.5	2	250	3.5	5	5.2	2.3	5	91	146	106		10	1	0.17	0.17
1/3/2012 13:45	1.25	2	325	3.75	5	2.1	2.3	4	91	142	93		11	1.3	0.22	0.21
1/4/2012 12:00	4	2	-	-	4	5.7	2.2	2	89	138	90		9.1	1.2	0.89	0.52
1/6/2012 12:00	2.5	2	150	2.5	5	3.7	2.5	2	89	149	88		10	1.2	0.44	0.13
1/9/2012 13:30	2.2	2	150	2.3	4.5	5.5	2.4	2	91	143	92		10	1.5	0.12	0.13
1/11/2012 10:00	3.1	2	-	-	3.1	2.6	2.3		88	136	90				0.45	0.07
1/12/12 8:30	-	-	-	-	-	7.5	2.3		88	139	90				0.54	0.15
1/13/2012 13:00	1.5	2	150	3.5	5	6.3	2.3	4	91	133	92		11	1.6	0.13	0.14
1/16/2012 14:45	2.5	2	150	2.5	5	4.4	2.2	4	92	134	91		12	1.7	0.06	0.06
1/17/2012 12:00	4.5	2	-	-	4.5	6.4	2.2		90	132	92				0.12	0.12
1/18/12 12:45	-	-	-	-	-	2.2	2.8		88	132	90				0.87	0.09
1/19/2012 13:45	2.4	2	-	-	2.4	6.4	2.6	2	90	138	90		12	1.1	0.66	0.23
1/20/2012 13:00	1.7	2	100	3.3	2.4	4.5	2.8		90	133	90				0.63	
1/25/12 9:15	-	-	-	-	-	1.6	2.3		90	132	91					

FIELD SAMPLE RESULTS

Date	Time	Target Flow Rate	MBfR Influent									
			pH	Temp	ORP	DO	Nitrate + Nitrite	Nitrite	Nitrate	Sulfide	Turbidity	
	Days	gpm	std unit	°C	mV	mg/L	mg/L - N	mg/L - N	mg/L - N	mg/L	NTU	
4/20/2011			-	-	-	-	-	-	-	-	-	-
4/21/2011			-	-	-	-	-	-	-	-	-	-
4/22/2011			-	-	-	7	8	0	8	-	-	-
4/25/2011			-	-	-	-	-	-	-	-	-	-
4/28/2011												
4/29/2011	1	5	7.43	19.5	90	11	8	0	8			
5/2/2011	4	5	7.55	18.7	108	11	8	0	8	0	H	
5/4/2011	6	5	7.48	19.0	100	9	8	0	8	0	H	
5/6/2011	8	5	7.42	19.2	120	9	8	0	8	0	H	
5/9/2011	11	5	7.28	17.4	102	8	8	0	8	0	H	
5/11/2011	13	5	7.47	18.7	90	9	7	0	7	0	H	
5/13/2011	15	8	7.31	18.9	96	9	8	0	8	0	H	0.18
5/16/2011	18	10	7.47	17.3	452	9	8	0	8	0	H	
5/18/2011	20	10	7.45	17.6	80	9	8	0	8	0	H	
5/20/2011	22	10	7.47	19	60	9	8	0	8	0	H	0.43
5/23/2011	25	8	7.58	18	100	9	8	0	8	0	H	
5/25/2011	27	8	7.54	18.9	120	9	7	0	7	0	H	
5/27/2011	29	8	7.53	19.2	125	9	7	0	7	0	H	
6/1/2011	34	10	7.53	18	166	9	8	0	8	0	H	0.19
6/3/2011	36	10	7.54	18.8	220	9	8.5	0	8.5	0	H	0.25
6/6/2011	39	12	7.52	18.7	60	10	7	0	7	0	H	0.25
6/10/2011	43	12	7.53	18.2	12.3	9	7.6	0	7.6	0	H	
6/13/2011	46	12	7.52	18.8	85	9	9	0	9	0	H	0.45
6/16/2011	49	12	7.66	19	161	9	9	0	9	0	H	0.97
6/20/2011	53	12	7.66	19.9	120							
6/27/2011	60	12	7.52	18.8	201	9	8.75	0	8.75	0	H	0.43
7/5/2011	68	16	7.52	18.9	90	9	8.5	0	8.5	0	H	0.45
7/11/2011	74	16	7.58	19	90	9	8	0	8	0	H	0.51
7/18/2011	81	10										
7/25/2011	88	20	7.56	20	135	9	8.5	0	8.5	0		0.49
7/29/2011	92											
8/1/2011	95	22	7.6	19	-120	9	9.5	0	9.5	0		0.5
8/2/2011	96											
8/5/2011	99											
8/8/2011	102	20	7.57	18.8	110	9	8	0	8	0		0.29
8/15/2011	109	18	7.56	18.8	115	9	7.5	0	7.5	0		
8/17/2011	111	18	7.57	19	90	10	6.5	0	6.5	0		0.51
8/19/2011	113	18	7.64	19.6	99	9	9	0	9	0		

Date	Time	Target Flow Rate	MBfR Influent								
			pH	Temp	ORP	DO	Nitrate + Nitrite	Nitrite	Nitrate	Sulfide	Turbidity
	Days	gpm	std unit	°C	mV	mg/L	mg/L - N	mg/L - N	mg/L - N	mg/L	NTU
8/26/2011	120	15	7.65	19.6	433	9	9	0	9	0	0.15
8/31/2011	125	15	7.52	19.9	175	9	8.2	0	8.2	0	0.469
9/2/2011	127	15	7.64	19.9	454	9	6	0	6	0	
9/7/2011	132	15	7.59	19.2	60	9	7.5	0	7.5	0	0.351
9/9/2011	134	10	7.54	19	135	9	8.5	0	8.5	0	0.297
9/12/2011	137	10	7.5	19	110	9	8.5	0	8.5	0	0.368
9/14/2011	139	10	7.64	19.8	-20	9	9	0	9	0	0.107
9/16/2011	141	20	7.63	18.9	130	9	9	0	9	0	
9/19/2011	144	5	7.67	24	86	9	8	0	8	0	0.12
10/3/2011	158	10	7.48	18.6	130	9	8.2	0	8.2	0	0.441
10/5/2011	160	10	7.67	18.6	179	9	9	0	9	0	
10/7/2011	162	10	7.35	19.1	135	9	8.75	0	8.75	0	
10/10/2011	165	5	7.42	19.9	140	9	8.7	0	8.7	0	0.295
10/12/2011	167	5	7.69	20.1	70	9	8.75	0	8.75	0	0.631
10/14/2011	169	5	7.6	20		9	8	0	8	0	
10/17/2011	172	10	7.57	19.3		9	10	0	10	0	0.29
10/19/2011	174	10	7.38	18.9	171	8	8.5	0	8.5	0	0.35
10/21/2011	176	10	7.57	18.8		9	9	0	9	0	0.24
10/26/2011	181	10	7.63	18.9	95	9	9	0	9	0	0.15
10/28/2011	183	10	7.65	19.3	246	9	9	0	9	0	0.13
10/31/2011	186	10	7.73	19.5	100	9	9	0	9	0	0.22
11/2/2011	188	10	7.51	19	90	8	8.5	0	8.5	0	0.273
11/4/2011	190	10	7.44	18.5	130	8	8.4	0	8.4	0	0.307
11/7/2011	193	10	7.53	18.6	301	9	9	0	9	0	0.075
11/9/2011	195	10	7.62	18.8	432	9	9	0	9	0	
11/11/2011	197	10	7.34	19	180	9	8.5	0	8.5	0	0.688
11/14/2011	200	10									
11/16/2011	202	10									
11/18/2011	204	10	7.53	18.5	120	9	9	0	9	0	0.067
11/22/2011	208	10	7.56	18.8	80	9	8.5	0	8.5	0	0.103
11/28/2011	214	8	7.35	19.1	340	8.5	8.7	0	8.7	0	0.139
11/30/2011	216	8	7.55	19.2	372	9	9	0	9	0	
12/2/2011	218	6									
12/5/2011	221	6									
12/9/2011	226	6									
12/14/2011	230	6	7.29	17.9	70	9	8.2	0	8.2	0	
12/16/2011	232	6	7.27	17.7	50	8	8.2	0	8.2	0	
12/19/2011	235	6	7.15	18.4	70	8	8	0	8	0	0.223

Date	Time	Target Flow Rate	MBfR Influent								
			pH	Temp	ORP	DO	Nitrate + Nitrite	Nitrite	Nitrate	Sulfide	Turbidity
	Days	gpm	std unit	°C	mV	mg/L	mg/L - N	mg/L - N	mg/L - N	mg/L	NTU
12/21/2011	237	6	7.61	18.2	374	9	8	0	8	0	0.065
12/23/2011	239	6	7.64	18.6	184	9	9	0	9	0	0.069
12/27/2011	243	6	7.58	18.4	402	9	9	0	9	0	0.087
12/28/2011	244	6	7.55	18.9	188	9	9	0	9	0	0.069
12/30/2011	246	6	7.39	18.1	80	8	8.75	0	8.75	0	0.264
1/3/2012	250	6	7.49	18.3	90	8.5	8.7	0	8.7	0	0.192
1/4/2012	251	6	7.54	19.6	368	9	9	0	9	0	0.105
1/6/2012	253	6	7.63	19.2	90	9	9	0	9	0	0.12
1/9/2012	256	6	7.44	18.8	140	8.5	8.75	0	8.75	0	0.199
1/11/2012	258	6	7.6	18.6	167	9	8.5	0	8.5	0	0.12
1/12/2012	259	6									
1/13/2012	260	6									
1/16/2012	263	6									
1/17/2012	264	6									
1/18/2012	265	6									
1/19/2012	266	6									
1/20/2012	267	6									
1/23/2012	270	6									
1/24/2012	271	6									
1/25/2012	272	6									

Date	Time	Target Flow Rate	Post Phosphate Injection	Lead Reactor (SP-100)									
			Phosphate	pH	Temp	ORP	DO	Nitrate + Nitrite	Nitrite	Nitrate	Phosphate	Sulfide	
	Days	gpm	mg/L - PO4	std unit	°C	mV	mg/L	mg/L - N	mg/L - N	mg/L - N	mg/L - PO4	mg/L	
4/20/2011				-	-	-	-	-	-	-		-	
4/21/2011				-	-	-	-	-	-	-		-	
4/22/2011				6.21	20.5	-424	2	7.5	0	7.5		-	
4/25/2011				8.39	23.6	-618	0.35	0	0	0		-	
4/28/2011													
4/29/2011	1	5		7.68	21.2	-17	3	7	0	7			
5/2/2011	4	5		7.38	19.7	-170	0.9	6	0.6	5.4		0	H
5/4/2011	6	5		6.58	24.4	88	0	2.4	0	2.4		0	H
5/6/2011	8	5		6.3	18.9	-260	0.2	1	0.1	0.9		0	H
5/9/2011	11	5		7.38	18.9	-235	0.7	0.3	0.4	-0.1		0	H
5/11/2011	13	5		6.38	18.6	-70	0	1.2	0	1.2		0	H
5/13/2011	15	8		7.8	20	-261	0.2	6.25	3	3.25		0	H
5/16/2011	18	10		7.38	18.6	-370	0.15	7	3	4		0	H
5/18/2011	20	10		7.39	18.6	-280	0.15	7	3	4		0	H
5/20/2011	22	10		7.7	19.6	-186	5.5	6.5	1.75	4.75		0	H
5/23/2011	25	8		7.48	19	-417	0.15	6	3	3		0	H
5/25/2011	27	8		7.46	18.8	-280	0.15	5	1.2	3.8		0	H
5/27/2011	29	8		7.58	20.3	-440	0.15	6	3	3		0	H
6/1/2011	34	10		7.41	19.6	-331	0.15	7	0.8	6.2		0	H
6/3/2011	36	10		7.42	19.4	-460	0.1	5	0.75	4.25		0	H
6/6/2011	39	12		7.54	18.5	-376	0.15	5.6	1	4.6		0	H
6/10/2011	43	12		7.5	19.5	-320	0.15	6	1.5	4.5		0	H
6/13/2011	46	12		7.53	19.7	-335	0.15	8	2.2	5.8		0	H
6/16/2011	49	12		7.52	19.9	-282	0.5	8	1.5	6.5		0	H
6/20/2011	53	12		7.49	22.7								
6/27/2011	60	12	3.5	7.71	20.6	-120	0.4	6	1.7	4.3	3.5	0	H
7/5/2011	68	16	0.8	7.78	20.2	-150	0.5	7.5	1.6	5.9	0.3	0	H
7/11/2011	74	16	0.8	7.62	19.8	-160	0.35	7.5	1.1	6.4		0	H
7/18/2011	81	10	1.63										
7/25/2011	88	20		7.65	21.7	-290	0.35	3	0.6	2.4		0	
7/29/2011	92												
8/1/2011	95	22		7.7	21	-301	0.15	2.6	0.8	1.8		0	
8/2/2011	96		1.5										
8/5/2011	99												
8/8/2011	102	20		7.51	20.1	-190	0.9	4.2	0.8	3.4		0	
8/15/2011	109	18		7.63	19.9	-350	0.8	3.3	0.6	2.7		0	
8/17/2011	111	18		7.62	20.7	-360	1.5	3.2	0.5	2.7		0	
8/19/2011	113	18	2	7.78	20.4	-322	0.8	4	1	3		0	

Date	Time	Target Flow Rate	Post Phosphate Injection	Lead Reactor (SP-100)								
			Phosphate	pH	Temp	ORP	DO	Nitrate + Nitrite	Nitrite	Nitrate	Phosphate	Sulfide
	Days	gpm	mg/L - PO4	std unit	°C	mV	mg/L	mg/L - N	mg/L - N	mg/L - N	mg/L - PO4	mg/L
8/26/2011	120	15	2.5	7.47	21.6	-403	0.9	3.3	0.75	2.55		0
8/31/2011	125	15	1.4	7.46	20.7	-370	1.5	2.2	0.4	1.8		0
9/2/2011	127	15	2	7.56	21.5	-380	1.5	3	0.6	2.4		0
9/7/2011	132	15	1.4	7.65	21.8	-270	0.9	4.1	0.6	3.5		0
9/9/2011	134	10		7.43	22.3	-435	2.5	2.8	0.4	2.4		0
9/12/2011	137	10	1.1	7.65	21.9	-315	0.7	1.6	0.2	1.4		0
9/14/2011	139	10	2	7.48	22.2	-192	0.9	3	0.75	2.25		0
9/16/2011	141	20		7.42	20	-285	1.5	4.5	0.75	3.75		0
9/19/2011	144	5	3.5	7.40	25.1	-293	0.25	0.5	0.1	0.4		0.1
10/3/2011	158	10		7.4	19.8	-255	0.2	3.8	0.8	3		0
10/5/2011	160	10	1.5	7.58	19.6	-428	0.15	2.1	0.75	1.35		0
10/7/2011	162	10		7.6	19.5	-410	0.2	2.8	0.75	2.05		0
10/10/2011	165	5		7.59	21.5		0.3	2.2	0.25	1.95		0
10/12/2011	167	5	0.6	7.42	22.4	-210	0.2	0.8	0.25	0.55		0
10/14/2011	169	5	1.5	7.2	22.5		0.25	0.4	0.2	0.2		0
10/17/2011	172	10		7.16	21.1		0.4	7.5	1.8	5.7		0
10/19/2011	174	10		7.27	20.9		0.3	2.8	0.25	2.55		0
10/21/2011	176	10		7.23	20.4		0.5	7	2	5		0
10/26/2011	181	10	1.7	7.32	20.4	-398	0.15	5.25	2	3.25		0
10/28/2011	183	10		7.27	20.9	-405	0.2	6	4	2		0
10/31/2011	186	10		7.15	21.5	-354	0.25	3.3	2	1.3		0
11/2/2011	188	10		7.56	20.5	-421	0.4	1.2	0.6	0.6		0
11/4/2011	190	10		7.61	20	-509	0.4	1.6	0.5	1.1		0
11/7/2011	193	10	1.5	7.57	20.6	-610	0.25	1.75	0.6	1.15		0
11/9/2011	195	10		7.36	20.9	-482	0.15	1.6	0.6	1		0
11/11/2011	197	10	1.1	7.44	21.2	-500	0.4	1.4	0.6	0.8		0
11/14/2011	200	10										
11/16/2011	202	10										
11/18/2011	204	10		7.47	20	-477	0.3	1.75	0.75	1		0
11/22/2011	208	10		7.57	19.3	-400	0.8	2	0.6	1.4		0
11/28/2011	214	8		7.38	20.7	-440	0.3	3.2	1.1	2.1		0
11/30/2011	216	8		7.6	20.1	-453	0.35	2.2	0.6	1.6		0
12/2/2011	218	6										
12/5/2011	221	6										
12/9/2011	226	6										
12/14/2011	230	6		7.62	19.2	-506	0.4	2.4	0.6	1.8		0
12/16/2011	232	6	0.3	7.55	18.8	-440	0.6	1.7	0	1.7		0
12/19/2011	235	6		7.5	19.4	-440	0.5	1.8	0.5	1.3		0

Date	Time	Target Flow Rate	Post Phosphate Injection	Lead Reactor (SP-100)								
			Phosphate	pH	Temp	ORP	DO	Nitrate + Nitrite	Nitrite	Nitrate	Phosphate	Sulfide
	Days	gpm	mg/L - PO4	std unit	°C	mV	mg/L	mg/L - N	mg/L - N	mg/L - N	mg/L - PO4	mg/L
12/21/2011	237	6		7.66	19	-511	0.25	2	0.75	1.25		0
12/23/2011	239	6	0.15	7.77	19.1	-514	0.35	2	0.8	1.2		0.6
12/27/2011	243	6	1.5	7.63	19.4	-521	0.25	2.25	0.85	1.4		0
12/28/2011	244	6	1.4	7.47	20.2	-493	0.2	2.1	0.85	1.25		0
12/30/2011	246	6	1.2	7.55	20.3	-490	0.3	1.8	0.6	1.2		0
1/3/2012	250	6	1.3	7.63	21.1	-440	0.1	2.1	0.75	1.35		0
1/4/2012	251	6	1.3	7.33	20.9	-487	0.15	1.6	0.85	0.75		0
1/6/2012	253	6	2.5	7.52	20.3	-402	0.3	2.25	0.9	1.35		0
1/9/2012	256	6	1.5	7.52	20.4	-353	0.3	1.5	0.3	1.2		0
1/11/2012	258	6	1.5	7.43	19.8	8	0.3	1.4	2	-0.6		0
1/12/2012	259	6	1.5									
1/13/2012	260	6	1.2									
1/16/2012	263	6	1.7									
1/17/2012	264	6	2									
1/18/2012	265	6	1.2									
1/19/2012	266	6	2									
1/20/2012	267	6	1.8									
1/23/2012	270	6										
1/24/2012	271	6										
1/25/2012	272	6	1.8									

Date	Time	Target Flow Rate	Lag Reactor (SP-200)										MBfR Solids Lead 1st	MBfR Solids LEAD 2nd	MBfR Solids Lag 1st	MBfR Solids Lag 2nd
			pH	Temp	ORP	DO	Nitrate + Nitrite	Nitrite	Nitrate	Phosphate	Sulfide	Turbidity	Turbidity	Turbidity	Turbidity	
	Days	gpm	std unit	°C	mV	mg/L	mg/L - N	mg/L - N	mg/L - N	mg/L - PO4	mg/L	NTU	NTU	NTU	NTU	
4/20/2011			-	-	-	-	-	-	-	-	-					-
4/21/2011			-	-	-	-	-	-	-	-	-					-
4/22/2011			5.83	19.7	-453	0.8	7.5	0	7.5		-					-
4/25/2011			8.73	23.5	-565	0.25	3.2	2	1.2		-					-
4/28/2011																-
4/29/2011	1	5	7.65	20.9	-127	3	6	0	6							-
5/2/2011	4	5	6.58	20.3	-103	3	2.4	0	2.4		0	H				-
5/4/2011	6	5	6.75	23.5	-210	3	2.4	0	2.4		0	H				-
5/6/2011	8	5	6.73	21.3	-205	3.5	0	0	0		0	H				-
5/9/2011	11	5	6.25	19	-190	3	0	0	0		0	H				-
5/11/2011	13	5	6.42	18.8	-170	1.5	0	0	0		0	H	-	-	-	-
5/13/2011	15	8	7.65	20.3	-565	0.02	0.5	0.3	0.2		0	H	-	-	-	-
5/16/2011	18	10	7.41	19	-552	0.05	5	3.5	1.5		0	H	-	-	-	-
5/18/2011	20	10	7.33	19	-530	0.1	6	3.5	2.5		0	H	-	-	-	-
5/20/2011	22	10	7.74	19.3	-375	2.5	7	1.6	5.4		0	H	-	-	-	-
5/23/2011	25	8	7.58	19.5	-560	0.05	3	3	0		0	H	-	-	-	-
5/25/2011	27	8	7.52	20	-452	0.05	2.5	1.5	1		0	H	-	-	-	-
5/27/2011	29	8	7.47	20.9	-583	0	1.5	1.5	0		0	H	-	-	-	-
6/1/2011	34	10	7.56	20.2	-495	0	3.75	3	0.75		0	H	-	-	-	-
6/3/2011	36	10	7.55	20.4	-570	0.05	1.5	1.3	0.2		0	H	-	-	-	-
6/6/2011	39	12	7.47	20.3	-545	0	2.2	1.7	0.5		0	H	-	-	-	-
6/10/2011	43	12	7.54	20.3	-540	0	5	3	2		0	H	--	--	--	--
6/13/2011	46	12	7.51	20.5	-570	0	3.5	2.4	1.1		0	H	--	--	--	--
6/16/2011	49	12	7.53	20.6	-526	0	4	3	1		0	H	--	--	--	--
6/20/2011	53	12	7.47	23												
6/27/2011	60	12	7.58	21.5	-610	0	0.4	0	0.4	1.5	0	H	--	--	--	--
7/5/2011	68	16	7.62	21.1	-355	0	1.8	1.2	0.6		0	H	--	--	--	--
7/11/2011	74	16	7.5	20.5	-515	0	0.5	0.3	0.2		0	H	--	--	--	--
7/18/2011	81	10														
7/25/2011	88	20	7.67	21.9	-540	0	0.4	0	0.4		0.2					
7/29/2011	92															
8/1/2011	95	22	7.71	21.7	-560	0	0.4	0	0.4		0		--	--	--	--
8/2/2011	96															
8/5/2011	99															
8/8/2011	102	20	7.46	20.9	-505	0	0	0	0		0		--	--	--	--
8/15/2011	109	18	7.7	20.7	-560	0.25	0.2	0	0.2		0		--	--	--	--
8/17/2011	111	18	7.71	21.2	-550	0.1	0.3	0	0.3		0		--	--	--	--
8/19/2011	113	18	7.44	21.2	-511	0.1	0.6	0.4	0.2		0.1		--	--	--	--

Date	Time	Target Flow Rate	Lag Reactor (SP-200)									MBfR Solids Lead 1st	MBfR Solids LEAD 2nd	MBfR Solids Lag 1st	MBfR Solids Lag 2nd
			pH	Temp	ORP	DO	Nitrate + Nitrite	Nitrite	Nitrate	Phosphate	Sulfide	Turbidity	Turbidity	Turbidity	Turbidity
	Days	gpm	std unit	°C	mV	mg/L	mg/L - N	mg/L - N	mg/L - N	mg/L - PO4	mg/L	NTU	NTU	NTU	NTU
8/26/2011	120	15	7.86	23	-540	0.15	0.1	0	0.1		0.4	--	--	--	--
8/31/2011	125	15	7.81	22	-540	0.1	0.4	0	0.4		0	--	--	--	--
9/2/2011	127	15	7.7	22.7	-550	0.1	0	0.05	0		0.6	3.4	7.11	12.6	14.6
9/7/2011	132	15	7.6	23.5	-515	0.1	0.8	0.1	0.7		0.3	--	--	--	--
9/9/2011	134	10	7.65	24.2	-520	0.15	0.1	0	0.1		0.8	3.92	6.52	15.7	17.2
9/12/2011	137	10	7.38	23.9	-390	0.2	0	0	0		2	--	--	--	--
9/14/2011	139	10	7.37	24.2	-293	0.1	0	0.1	-0.1		1				
9/16/2011	141	20	7.53	21.1	-430	0.2	0.8	0.4	0.4		0.05				
9/19/2011	144	5	--	--	--	--	--	--	--		--				
10/3/2011	158	10	7.46	20.7	-566	0	0.4	0	0.4		0				
10/5/2011	160	10	7.48	20.6	-547	0.05	0	0	0		1.5				
10/7/2011	162	10	7.5	20.4	-530	0.05	0.2	0	0.2		0.2				
10/10/2011	165	5	7.52	21.5		0	0	0	0		3.5				
10/12/2011	167	5	7.6	23.6	-480	0.05	0	0	0		4.5				
10/14/2011	169	5	7.52	24		0.05	0	0	0		6				
10/17/2011	172	10	7.59	21.8		0.1	0.7	0.4	0.3		0				
10/19/2011	174	10	7.52	21.1		0.1	0	0	0		0.4				
10/21/2011	176	10	7.58	21.3		0.1	0.6	0.4	0.2		0.1	3.39	5.14	83.4	37.9
10/26/2011	181	10	7.63	21.2	-453	0.1	0.3	0.1	0.2		0.7				
10/28/2011	183	10	7.67	21.5	-506	0.1	0.5	0.5	0		0.1				
10/31/2011	186	10	7.66	22	-427	0.1	0.1	0.1	0		0.4				
11/2/2011	188	10	7.55	20.9	-491	0.1	0	0	0		1				
11/4/2011	190	10	7.59	20.4	-540	0.2	0	0	0		0.5	18.9	19.9	16.9	15.2
11/7/2011	193	10	7.57	20.9	-440	0.1	0	0	0		1				
11/9/2011	195	10	7.63	21.3	-487	0.1	0	0	0		1.3				
11/11/2011	197	10	7.65	21.8	-536	0.25	0	0	0		1.2				
11/14/2011	200	10													
11/16/2011	202	10													
11/18/2011	204	10	7.61	20.5	-500	0.05	0	0	0		0.4				
11/22/2011	208	10	7.66	20.5	-530	0.1	0	0	0		0.1				
11/28/2011	214	8	7.57	21.5	-553	0	0.1	0.1	0		0.1				
11/30/2011	216	8	7.41	21.3	-501	0	0	0	0		0.3				
12/2/2011	218	6									2.5				
12/5/2011	221	6													
12/9/2011	226	6													
12/14/2011	230	6	7.49	19.8	-547	0	0.4	0	0.4		0.5				
12/16/2011	232	6	7.47	19.6	-490	0.1	0	0	0		0.8				
12/19/2011	235	6	7.57	20.4	-515	0.1	0.4	0	0.4		1				

Date	Time	Target Flow Rate	Lag Reactor (SP-200)									MBfR Solids Lead 1st	MBfR Solids LEAD 2nd	MBfR Solids Lag 1st	MBfR Solids Lag 2nd
			pH	Temp	ORP	DO	Nitrate + Nitrite	Nitrite	Nitrate	Phosphate	Sulfide	Turbidity	Turbidity	Turbidity	Turbidity
	Days	gpm	std unit	°C	mV	mg/L	mg/L - N	mg/L - N	mg/L - N	mg/L - PO4	mg/L	NTU	NTU	NTU	NTU
12/21/2011	237	6	7.71	19.8	-543	0.05	0	0	0		0.6				
12/23/2011	239	6	7.54	19.9	-514	0.1	0	0	0		0.6				
12/27/2011	243	6	7.68	20.4	-533	0.1	0	0	0		0.6				
12/28/2011	244	6	7.58	21.3	-491	0.1	0	0	0		0.6				
12/30/2011	246	6	7.46	21.3	-540	0.05	0.4	0	0.4		2	19.6	10.1	18.9	9.4
1/3/2012	250	6	7.54	21.9	-570	0	0.4	0	0.4		1.4				
1/4/2012	251	6	7.48	21.9	-484	0.1	0	0	0		2.5				
1/6/2012	253	6	7.6	21.3	-485	0.15	0	0	0		0.3				
1/9/2012	256	6	7.64	21.6	-528	0.1	0	0	0		1				
1/11/2012	258	6	7.55	21.1	-424	0.15	0.25	0.25	0		0.05	34	18	44	19
1/12/2012	259	6													
1/13/2012	260	6													
1/16/2012	263	6													
1/17/2012	264	6													
1/18/2012	265	6													
1/19/2012	266	6													
1/20/2012	267	6													
1/23/2012	270	6													
1/24/2012	271	6													
1/25/2012	272	6													

Date	Time	Target Flow Rate gpm	Aeration						Media Filter Effluent					Post Media Filter	Filter Backwash
	Days		pH	Temp	ORP	DO	Sulfide	Turbidity	pH	Temp	ORP	DO	Turbidity	Cl Residual	Turbidity
			std unit	°C	mV	mg/L	mg/L	NTU	std unit	°C	mV	mV	NTU	mg/L	NTU
4/20/2011			-	-	-	-	-	-	-	-	-	-	-	-	-
4/21/2011			-	-	-	-	-	-	-	-	-	-	-	-	-
4/22/2011			-	-	-	-	-	-	-	-	-	-	-	-	-
4/25/2011			-	-	-	-	-	-	-	-	-	-	-	-	-
4/28/2011														-	-
4/29/2011	1	5	7.87	20.4	6	8								-	-
5/2/2011	4	5	7.13	20.1	20	7	0	0.99	7.24	20.4	136		0.36	-	-
5/4/2011	6	5	7.44	22.6	65	7	0	4.35	7.68	23.1	162		1.32	-	-
5/6/2011	8	5	7.91	20.5	90	7	0		-	-	-			-	-
5/9/2011	11	5	6.86	18.6	-35	7	0	2.01	6.98	17.8	85		0.76	-	-
5/11/2011	13	5	6.85	19.4	-5	3.5	0	2.46	6.83	19.5	50		1.05	-	-
5/13/2011	15	8	8.01	20.2	-57	7	0	1.01	7.94	20.4	143	6	1.09	0.15	-
5/16/2011	18	10	7.79	18.9	-117	7	0	0.62	7.79	18.7	117	5.5	0.42	0	-
5/18/2011	20	10	7.77	18.9	-80	7	0	1.16	7.77	18.6	110	5.5	0.64	0	-
5/20/2011	22	10	7.98	19.5	-70	7	0	0.31	7.93	19.6	80	7	0.35	0	-
5/23/2011	25	8	8	19.4	-80	7	0	1.04	7.96	19.3	140	6	0.3	0	-
5/25/2011	27	8	7.97	19.9	-60	5.5	0	0.51	7.93	20	68	6	0.47	0	-
5/27/2011	29	8	7.92	20.7	-90	7	0	1.22	7.85	20.9	110	7	0.38	0	-
6/1/2011	34	10	7.91	20.1	-114	7	0	0.81	7.87	20.1	127	7	0.39	0	-
6/3/2011	36	10	7.94	20.0	-80	4.5	0	0.61	7.88	20.3	90	7	0.53	5	-
6/6/2011	39	12	7.83	20.3	-100	4.5	0	0.72	7.79	20.3	15	5.5	0.46	0	-
6/10/2011	43	12	7.85	20.2	-110	6	0	0.6	7.83	20.2	80	6	0.44	3	-
6/13/2011	46	12	7.8	20.4	-90	6	0	0.86	7.73	20.5	100	6	0.56	2.5	-
6/16/2011	49	12	7.84	20.6	-75	7	0	1.31	7.76	19.6	151	6	0.38	0	-
6/20/2011	53	12												>5	
6/27/2011	60	12	7.86	21.4	-130	6.5	0	0.69	7.81	21.6	90	7	0.34	7.5	-
7/5/2011	68	16	7.87	21.1	-65.4	3.5	0	0.74	7.78	21.3	95	5	0.6	0	-
7/11/2011	74	16	7.76	20.3	-70	7	0	0.8						off	
7/18/2011	81	10													
7/25/2011	88	20	7.85	21.9	-244	6	0.4	0.6	7.82	23.1	-90	7	0.31	1.25	
7/29/2011	92														
8/1/2011	95	22	7.88	21.7	-206	5.5	0.2	0.62	8.01	22.1	-73	6	0.51	0.3	
8/2/2011	96														
8/5/2011	99														
8/8/2011	102	20	7.68	20.8	-220	6	0.1	0.422	7.65	21.0	10	6	0.304	1.0	
8/15/2011	109	18	7.91	20.6	-290	6	0		7.87	2.7	-110	6		1.1	
8/17/2011	111	18	7.85	21	-320	6	0.1	0.383	7.84	21.2	-120	7	0.264	1.25	
8/19/2011	113	18	7.65	21.1	-272	5.5	0.05	0.79	7.63	21.4	-134	3.5	0.32	1	48

Date	Time	Target Flow Rate	Aeration						Media Filter Effluent					Post Media Filter	Filter Backwash
	Days		gpm	pH	Temp	ORP	DO	Sulfide	Turbidity	pH	Temp	ORP	DO	Turbidity	Cl Residual
			std unit	°C	mV	mg/L	mg/L	NTU	std unit	°C	mV	mV	NTU	mg/L	NTU
8/26/2011	120	15	7.99	22.9	-293	5	0.2	1.3	7.92	23.5	-69	2.5	0.3	1	
8/31/2011	125	15	8.01	22	-285	5.5	0	1.3	7.95	22.1	-20	6	0.503	2.6	
9/2/2011	127	15	8	22.6	-250	6	0.3	1.17	7.88	22.9	38	5	0.257	3.75	
9/7/2011	132	15	7.9	23	-245	4.5	0.1	0.924	7.82	23.6	-90	6	0.409	0.9	
9/9/2011	134	10	7.99	24.1	-231	6.5	0.6	1.13	7.84	24.3	-80	7	0.306	0.6	0.489
9/12/2011	137	10	7.82	23.7	-275	5.5	1.1	1.78	7.65	23.8	-232	6	0.385	0.5	
9/14/2011	139	10	7.82	24	-247	7	0.5	1.88	7.66	24.1	-134	2.5	0.39	0.6	
9/16/2011	141	20	7.83	21.1	-195	5.5	0		7.73	21.1	-88	4.5		0.4	17.7
9/19/2011	144	5	8.02	24.8	-107	6.5	0	2.87	7.76	25.2	-102	4.5	0.45	>5	
10/3/2011	158	10	7.94	20.8	-120	5	0.3	2.96	7.85	20.8	50	7	0.679	0.3	
10/5/2011	160	10	7.89	20.5	-237	7	0.9		7.82	20.3	30	4.5		0*	
10/7/2011	162	10	7.88	20.5	-232	5	0.8				-140	6		0.6	
10/10/2011	165	5	8.01	22		4	4	2.67		21.8		5	1.59	>5	
10/12/2011	167	5	8.12	24.2	-305	5	3	2.8	8.01	24.5	-270	6	1.68	0.2	
10/14/2011	169	5	8.06	23.9		7	4		7.88	24.2		0.05		2.5	
10/17/2011	172	10	7.94	21.7		7	0	2.99	7.76	21.8		4.5	1.5	2	27.4
10/19/2011	174	10	7.86	21.6		5	0.1	2.5	7.77	21.6		6	0.9	1	
10/21/2011	176	10	7.93	21.2		5.5	0	3.01	7.83	21.1		5.5	1.66	1	
10/26/2011	181	10	7.98	21.1	-215	7	0.4	1.78	7.8	21	30	4	0.36	1.75	
10/28/2011	183	10	7.98	21.4	-153	7	0.05	2.28	7.85	21.4	85	5.5	0.39	1.75	
10/31/2011	186	10	7.93	21.8	-144	7	0.15	1.69	7.85	22	58	4.5	0.22	3.5	
11/2/2011	188	10	7.82	20.6	-202	6	0.8	1.22	7.78	20.7	-50	6.5	0.189	2	
11/4/2011	190	10	7.82	20.6	-260	5	0.4	1.05	7.79	20.4	-54	6	0.179	1.2	
11/7/2011	193	10	7.93	20.7	-214	7	0.8	1.2	7.81	20.6	50	3.5	0.132	2	
11/9/2011	195	10	7.98	21.1	-222	7	0.8		7.84	21	52	3.5		1.9	
11/11/2011	197	10	7.95	21.7	-254	6	0.8	0.898	7.83	21.3	-20	6.5	0.229	1.2	
11/14/2011	200	10													
11/16/2011	202	10													
11/18/2011	204	10	7.98	20.3	-173	7	0.1	1.24	7.93	20.1	74	5.5	0.288	1.5	
11/22/2011	208	10	7.98	20.4	-190	5	0.1	1.78	7.85	20.3	20	6	0.201	0.2	
11/28/2011	214	8	7.98	21.3	-230	5.5	0	0.897	7.86	21.6	-20	6	0.204	4	
11/30/2011	216	8	7.89	21.2	-156	7	0.1		7.72	21.2	55	5.5	0.211	2	
12/2/2011	218	6													
12/5/2011	221	6													
12/9/2011	226	6													
12/14/2011	230	6	7.88	19.8	-276	6	0.3		7.75	19.5	-160	7		0.4	
12/16/2011	232	6	7.91	19.3	-220	5.5	0.6	1.21	7.71	19	-140	6			
12/19/2011	235	6	8	20.1	-230	5.5	0.5	1.46	7.82	19.8	-180	6	0.694	1.5	

Date	Time	Target Flow Rate	Aeration						Media Filter Effluent					Post Media Filter	Filter Backwash
			pH	Temp	ORP	DO	Sulfide	Turbidity	pH	Temp	ORP	DO	Turbidity	Cl Residual	Turbidity
	Days	gpm	std unit	°C	mV	mg/L	mg/L	NTU	std unit	°C	mV	mV	NTU	mg/L	NTU
12/21/2011	237	6	8.12	19.4	-188	7	0.1	1.4	7.97	19.3	-10	5.5	0.132	2.5	
12/23/2011	239	6	8.02	19.6	-205	7	0.25	1.6	7.88	19.5	-49	4.5	0.111	2.5	
12/27/2011	243	6	8.09	20	-182	5.5	0.2	1.3	7.9	20	-17	5.5	0.175	2	
12/28/2011	244	6	8.04	21	-200	7	0.2		7.8	21	-20	5.5	0.116	1.6	
12/30/2011	246	6	7.92	21	-235	6	1.5	1.89	7.67	21.1	-180	6	0.207	0	
1/3/2012	250	6	7.99	21.4	-210	7	1.1	1.69	7.71	21.3	-145	7.5	0.207	0	
1/4/2012	251	6	7.97	21.6	-211	7	1	1.86	7.73	21.8	-132	3.5	0.295	2.5	43.1
1/6/2012	253	6	8.04	21.1	-160	7	0.05	1.72	7.87	21.1	30	5.5	0.178	1.5	
1/9/2012	256	6	7.86	21.4	-182	5.5	0.4	1.76	7.82	21.3	-40	6	0.163	1.5	
1/11/2012	258	6	8.02	20.8	-31	7	0	1.26	7.89	20.7	103	7	0.111	1.1	
1/12/2012	259	6													
1/13/2012	260	6													
1/16/2012	263	6												0.4	
1/17/2012	264	6												0.4	
1/18/2012	265	6													
1/19/2012	266	6													
1/20/2012	267	6													
1/23/2012	270	6													
1/24/2012	271	6												0.5	
1/25/2012	272	6												0.2	

Date	Time	Target Flow Rate	Finished Water (Product)										Outfall	
			pH	Temp	ORP	DO	Nitrate + Nitrite	Nitrite	Nitrate	Sulfide	Turbidity	Cl Residual	pH	Temperature
	Days	gpm	std unit	°C	mV	mg/L	mg/L - N	mg/L - N	mg/L - N	mg/L	NTU	mg/L	std unit	°C
4/20/2011			-	-	-	-	-	-	-	-	-	-		
4/21/2011			-	-	-	-	-	-	-	-	-	-		
4/22/2011			-	-	-	-	-	-	-	-	-	-		
4/25/2011			-	-	-	-	-	-	-	-	-	-		
4/28/2011												-		
4/29/2011	1	5										-		
5/2/2011	4	5	7.47	20.4	133	7	2	0	2	0	0.79	-		
5/4/2011	6	5	7.58	22.8	176	5.5	1.2	0	1.2	0	0.75	-		
5/6/2011	8	5	7.14	21.4	120	5.5	0	0	0	0		-		
5/9/2011	11	5	6.93	17.1	108	7	0	0	0	0	0.66	-		
5/11/2011	13	5	7.10	19.2	90	3.5	0	0	0	0	1.31	-		
5/13/2011	15	8	7.94	20.6	300	8	0.5	0.15	0.35	0	1.01	-		
5/16/2011	18	10	7.85	17.7	180	7	3.5	3.5	0	0	0.48	-		
5/18/2011	20	10	7.82	17.7	300	6	6	3.5	2.5	0	0.39	-		
5/20/2011	22	10	7.85	19.3	100	8	6.5	1.75	4.75	0	0.21	-		
5/23/2011	25	8	7.98	18.4	177	6	3	3	0	0	0.22	-		
5/25/2011	27	8	7.92	19.8	320	7	1.75	1.6	0.15	0	0.51	-		
5/27/2011	29	8	7.91	19.9	143	7	2	2	0	0	0.51	-		
6/1/2011	34	10	7.93	19.6	229	7	3.75	3	0.75	0	0.27	-		
6/3/2011	36	10	7.89	20	33	7.5	1.6	1.5	0.1	0	0.47	-		
6/6/2011	39	12	7.93	19.3	250	7	3.4	1.4	2	0	0.42	0		
6/10/2011	43	12	7.88	19.4	305	5.5	4.5	2.4	2.1	0	0.36	0		
6/13/2011	46	12	7.68	20.2	150	5.5	3	1.7	1.3	0	0.38	0		
6/16/2011	49	12	7.87	20.4	65	6	4	3	0	0	0.77	0		
6/20/2011	53	12												
6/27/2011	60	12	7.95	21.5	255	7	0	0	0	0	0.38	6		
7/5/2011	68	16	7.8	21.3	240	6	1.6	1	0.6	0	1.2	0	7.69	23.1
7/11/2011	74	16										off	7.64	21.8
7/18/2011	81	10											7.51	21.9
7/25/2011	88	20	7.8	22.8	100	8	0	0	0	0	0.23	0.4	7.56	24.3
7/29/2011	92													
8/1/2011	95	22	8.3	21.9	90	6	0	0	0	0	0.49	0	7.79	22.4
8/2/2011	96													
8/5/2011	99													
8/8/2011	102	20	7.68	20.9	264	7	0	0	0	0	0.147	0.2	7.6	20.9
8/15/2011	109	18	7.89	20.8	230	7	0	0	0	0		0.03	7.69	20.7
8/17/2011	111	18	7.87	21	250	8	0.2	0	0.2	0	0.211	0.9	7.66	21.2
8/19/2011	113	18	7.7	21.7	590	4	0.8	0	0.8	0	0.214	0.7		

Date	Time	Target Flow Rate	Finished Water (Product)										Outfall	
			pH	Temp	ORP	DO	Nitrate + Nitrite	Nitrite	Nitrate	Sulfide	Turbidity	Cl Residual	pH	Temperature
	Days	gpm	std unit	°C	mV	mg/L	mg/L - N	mg/L - N	mg/L - N	mg/L	NTU	mg/L	std unit	°C
8/26/2011	120	15	7.92	24.4	639	3	0	0	0	0	0.375	2	7.75	24
8/31/2011	125	15	7.89	21.9	224	8	0.2	0	0.2	0	0.429	1.1	7.6	22.3
9/2/2011	127	15	7.97	23.4	681	5.5	0.25	0	0.25	0	0.251	1.75	7.87	22.9
9/7/2011	132	15	7.72	23.2	120	8	0.6	0	0.6	0	0.311	0.4	7.64	23.5
9/9/2011	134	10	7.83	24.1	290	8	0	0	0	0	0.276	0.2	7.48	24.2
9/12/2011	137	10	7.68	23.7	355	7	0	0	0	0	0.343	0.2	7.6	23.2
9/14/2011	139	10	7.73	24	318	3	0.2	0	0.2	0	0.29	0.2	7.67	24.1
9/16/2011	141	20	7.78	20.9	379	4.5	0.7	0	0.7	0	0.45	0.05	7.86	20.8
9/19/2011	144	5	7.88	25.4	733	6.5	0.5	0	0.5	0	0.37	>5	7.55	24.8
10/3/2011	158	10	7.84	21.1	90	8	0.4	0	0.4	0	0.503	0	7.59	21.1
10/5/2011	160	10	7.89	18.6	59	6.5	0.5	0	0.5	0	0.44	0*	7.70	18.8
10/7/2011	162	10			90	7	0.2	0	0.2	0		0.1		
10/10/2011	165	5	7.89	21.2		6.5	0.2	0	0.2	0	1.26	5	7.52	21.3
10/12/2011	167	5	7.91	24.4	-130	7.5	0	0	0	0	12.1	0.1	7.6	25.1
10/14/2011	169	5	7.91	24.3		1	0	0	0	0	8.58	0.4	7.48	24.1
10/17/2011	172	10	7.77	22		5.5	0.6	0	0.6	0	0.85	1.25	7.88	22
10/19/2011	174	10	7.79	21.3		7	0.2	0	0.2	0	0.8	0.4	7.67	21.1
10/21/2011	176	10	7.85	20.5		7	0.6	0	0.6	0	0.94	0.3	7.66	20.5
10/26/2011	181	10	7.86	20.3	659	5.5	0.4	0	0.4	0	0.38	1.5	7.73	19
10/28/2011	183	10	7.89	21.5	639	7	0.5	0	0.5	0	0.3	1.25	7.65	21.3
10/31/2011	186	10	7.86	22.1	703	5.5	0.4	0	0.4	0	0.11	1.75	7.66	22.1
11/2/2011	188	10	7.83	20.5	598	8	0	0	0	0	0.175	2	7.70	21
11/4/2011	190	10	7.86	20.2	620	7	0	0	0	0	0.157	1	7.68	20.1
11/7/2011	193	10	7.90	18.8	641	4.5	0	0	0	0	0.144	1.75	7.68	18.6
11/9/2011	195	10	7.92	19.4	655	4.5	0	0	0	0		1.6	7.69	19.6
11/11/2011	197	10	7.87	21.4	530	8	0	0	0	0	0.238	1		
11/14/2011	200	10												
11/16/2011	202	10												
11/18/2011	204	10	7.98	18.6	616	5.5	0	0	0	0	0.268	1.25	7.6	18.4
11/22/2011	208	10	7.91	19.8	320	7.5	0	0	0	0	0.197	0.1	7.58	20.1
11/28/2011	214	8	8.02	21.2	585	7	0.1	0	0.1	0	0.279	3	7.49	21.9
11/30/2011	216	8	7.9	21	640	7	0.4	0	0.4	0		1.5	7.45	20.8
12/2/2011	218	6										1.5		
12/5/2011	221	6											7.37	17.5
12/9/2011	226	6											7.19	20.3
12/14/2011	230	6	7.82	18.6	500	7.5	0	0	0	0		0.2	7.26	18.7
12/16/2011	232	6	7.81	17.8	510	7	0	0	0	0		0.6	7.58	17.5
12/19/2011	235	6	7.84	19.3	660	7	0	0	0	0	0.512	1.2	7.51	19.1

Date	Time	Target Flow Rate	Finished Water (Product)										Outfall	
			pH	Temp	ORP	DO	Nitrate + Nitrite	Nitrite	Nitrate	Sulfide	Turbidity	Cl Residual	pH	Temperature
	Days	gpm	std unit	°C	mV	mg/L	mg/L - N	mg/L - N	mg/L - N	mg/L	NTU	mg/L	std unit	°C
12/21/2011	237	6	8.11	18.1	665	5.5	0.05	0	0.05	0	0.142	1.5	7.79	16.6
12/23/2011	239	6	7.97	18.3	630	5.5	0.1	0	0.1	0	0.124	1.5	7.83	17.5
12/27/2011	243	6	7.96	18.9	630	7	0.4	0	0.4	0	0.175	1.1	7.75	18.5
12/28/2011	244	6	7.89	20.6	596	7	0.5	0	0.5	0		1	7.7	20.6
12/30/2011	246	6	7.44	20.9	120	7	0.4	0	0.4	0	0.216	0	7.38	20.7
1/3/2012	250	6	7.39	20.9	60	8	0.6	0	0.6	0		0	7.44	20.9
1/4/2012	251	6	7.76	22	690	4.5	0.7	0	0.7	0		2	7.42	22.7
1/6/2012	253	6	7.95	20.6	673	7	0.1	0	0.1	0	0.145	1.2	7.63	20.8
1/9/2012	256	6	7.85	21.1	385	7	0.4	0	0.4	0	0.341	1	7.49	21.6
1/11/2012	258	6	7.94	20.3	543	7	0.25	0	0.25	0	0.126	0.9	7.67	19.8
1/12/2012	259	6										0.9		
1/13/2012	260	6										0.8		
1/16/2012	263	6										0.1	7.58	20
1/17/2012	264	6										0.1	7.51	20.1
1/18/2012	265	6										0.7	7.68	19.7
1/19/2012	266	6										0.4		
1/20/2012	267	6										0.7		
1/23/2012	270	6											7.58	19.5
1/24/2012	271	6										0	7.64	19.5
1/25/2012	272	6										0	7.69	19.1

Notes:

Qualifiers:

H Sample analysis performed past method-specified holding time.

* Leak at injection pump discharge fitting, chlorine turned off.

APPENDIX D FIELD METHODS

1.0 BATCH TEST PRELIMINARY TESTING

A preliminary batch test was conducted on September 16, 2010, to evaluate effects of operating the system in batch mode with continued recirculation. The goal was to determine if it was possible to attain the treatment goal of effluent perchlorate concentrations below 6 milligrams per liter (mg/L).

1.1 EXPERIMENTAL METHODS

The normal operating conditions were changed to achieve a nitrate and nitrite (NO_x) concentration over 2.5 milligrams of nitrogen per liter (mg-N/L) in the lead reactor:

- feed flow was 20 gallons per minute (gpm)
- MBfR1 hydrogen pressure was 20 pounds per square inch gauge (psig)
- MBfR2 hydrogen pressure was 28 psig

The influent and effluent flow to the membrane biofiltration reactor (MBfR) vessels was stopped at the beginning of the test. The lead reactor (MBfR2) served as the first batch reactor. The NO_x in the batch reactor was measured using an online nitrate analyzer. NO_x concentrations quickly dropped from greater than 2.5 mg-N/L to almost non-detectable limits over 20 minutes. Samples were collected from the recycle pump discharge line and were sent to the lab for analysis. The online nitrate analyzer sample tap was at the recycle pump discharge. Samples were collected according to Table 1, while monitoring the online nitrate analyzer readings via the Operator Interface Terminal (OIT). The third sample was collected when NO_x was at the lowest concentration read by the online nitrate analyzer. Theoretically, this would be a zero concentration. However, the lowest concentration of NO_x was determined to be at the point where NO_x readings stopped decreasing and began to increase slightly.

Table 1 Sample Intervals

Sample	Sample Collection Trigger
1	At 2.5 mg-N/L
2	At 0.5 mg-N/L
3	Below detection (lowest value)
4	10 minutes after sample #3
5	20 minutes after sample #3
6	30 minutes after sample #3

After the batch experiment on MBfR2 was complete, feed flow was restored for several hours with MBfR1 as the lead reactor. After stabilization of NO_x readings was achieved, feed flow was turned off again and this test was repeated with MBfR1 as the batch reactor. Preliminary testing results are shown in Table 2.

Table 2 Preliminary Testing Results

Recirculation Flow Rate (gpm)	Sample	Sample Collection Trigger	Time
MBfR1: 280	R1-1	At 2.5 mg-N/L	12:08
MBfR2: 280	R1-2	At 0.5 mg-N/L	12:18
	R1-3	Below detection (lowest value)	12:25
	R1-4	10 minutes after sample #3	12:35
	R1-5	20 minutes after sample #3	12:45
	R1-6	30 minutes after sample #3	12:55
MBfR1: 280	R2-1	At 2.5 mg-N/L	15:13
MBfR2: 280	R2-2	At 0.5 mg-N/L	15:21
	R2-3	Below detection (lowest value)	15:27
	R2-4	10 minutes after sample #3	15:37
	R2-5	20 minutes after sample #3	15:47
	R2-6	30 minutes after sample #3	15:57

Note: R1 is MBfR vessel 1 and R2 is MBfR vessel 2.

2.0 BATCH TESTING

The team conducted the batch tests on November 14 and 15, 2010, to determine nitrate, nitrite and perchlorate removal following a change of the internal recirculation flow rate. The influent flow to the MBfR was stopped and the water only recirculated within modules. Results from the preliminary batch test demonstrated that perchlorate and nitrate were completely reduced. This series of tests was conducted to obtain more accurate kinetics data for perchlorate, nitrate, and sulfate under variable recirculation flow rates.

2.1 EXPERIMENTAL METHODS

On the day prior to the experiment, the operating parameters remained at normal operating conditions:

- influent feed flow rate was 10 gpm
- MBfR1 hydrogen pressure was 15 psig
- MBfR2 hydrogen pressure was 17.5 psig
- MBfR1 recirculation flow rate is 100 gpm
- MBfR2 recirculation flow rate 180 gpm

The water level was controlled by manually adjusting the overflow valve to prevent a high-level alarm from shutting down the system or a low-water level from exposing the module fibers. The pump discharge supplied influent flow to the online nitrate analyzer. The nitrate analyzer effluent flow was discharged to the top of the lead reactor. The nitrate analyzer was cleaned by sliding the flow assembly away from the sensor and spraying DI water around the cuvette gap area to remove growth on the lens and also allow flow around the assembly's window. Operating

conditions were set to facilitate the experiment and achieve approximately 5 mg-N/L NO_x in the lead reactor:

- The sparge interval was increased so that a sparge event would not trigger during sampling
- MBfR1 hydrogen pressure was 7 psig
- MBfR1 recirculation flow rate was 100 gpm
- MBfR2 sample valve was in “hand” operation
- MBfR1 sample valve was off
- The feed flow rate was increased to 22 gpm, which was the maximum feed flow allowed before triggering a high level alarm in the tanks
- The overflow valve was completely opened to prevent a high-level alarm, which would stop the system
- The MBfR2 module purge lines were manually vented
- MBfR1 and MBfR2 module purge lines were placed in the “off” position during the batch tests.

When NO_x levels in MBfR2 (lead reactor) were greater than 5.5 mg-N/L the feed was discontinued by placing the system influent pump and the system influent solenoid valve in the off position. The overflow valve was closed to prevent draining of the MBfR reactors. The recirculation pump continued to operate. The nitrate concentration was closely monitored using the OIT. When NO_x in MBfR2 (batch reactor) dropped below 5.5 mg-N/L, time was recorded at each concentration. Water samples were collected from the recycle pump discharge at the specified times to be analyzed for nitrate, nitrite, and perchlorate. Table 3 shows when samples were collected from the lead reactor based on nitrate analyzer readings.

Table 3 Sample Intervals

Sample	Sample Collection Trigger
0	At 5.0 mg-N/L
1	At 2.5 mg-N/L
2	At 0.5 mg-N/L
3	Below detection (lowest value)
4	5 minutes after sample #3
5	10 minutes after sample #3
6	20 minutes after sample #3

Sample #3 had the lowest nitrate reading and was near or below the detection limit of the online nitrate analyzer. The lowest value of NO_x was determined to be at the point where NO_x readings stopped decreasing and began to increase slightly. After the last sample was collected, the process was repeated at a different recirculation flow rate. For all flow rates and results, refer to Table 4 for MBfR2 (R2) batch test and Table 5 for Batch Test #2. After the batch testing was completed, the system was returned to its normal operating parameters.

Table 4 MBfR2 (R2) Batch Test Sample Collection Times, Day 1

Recirculation Rate (gpm)	Sample	Sample Collection Trigger	Time
MBfR1: 100 MBfR2: 180	Initial Reading	5.5 mg-N/L	11:04
	R2-0-180gpm	At 5.0mg-N/L	11:06
	R2-1-180gpm	At 2.5mg-N/L	11:15
	R2-2-180gpm	At 0.5mg-N/L	11:23
	R2-3-180gpm	Below detection (lowest value)	11:29
	R2-4-180gpm	5 minutes after sample #3	11:34
	R2-5-180gpm	10 minutes after sample #3	11:39
	R2-6-180gpm	20 minutes after sample #3	11:49
MBfR1: 100 MBfR2: 60	Initial Reading	5.5 mg-N/L	12:17
	R2-0-60gpm	At 5.0mg-N/L	12:18
	R2-1-60gpm	At 2.5mg-N/L	12:30
	R2-2-60gpm	At 0.5mg-N/L	12:40
	R2-3-60gpm	Below detection (lowest value)	12:49
	R2-4-60gpm	5 minutes after sample #3	12:54
	R2-5-60gpm	10 minutes after sample #3	12:59
	R2-6-60gpm	20 minutes after sample #3	13:09
MBfR1: 100 MBfR2: 120	Initial Reading	5.5 mg-N/L	13:50
	R2-0-120gpm	At 5.0mg-N/L	13:50
	R2-1-120gpm	At 2.5mg-N/L	13:59
	R2-2-120gpm	At 0.5mg-N/L	14:11
	R2-3-120gpm	Below detection (lowest value)	14:15
	R2-4-120gpm	5 minutes after sample #3	14:20
	R2-5-120gpm	10 minutes after sample #3	14:25
	R2-6-120gpm	20 minutes after sample #3	14:35
MBfR1: 100 MBfR2: 90	Initial Reading	5.5 mg-N/L	15:10
	R2-0-90gpm	At 5.0mg-N/L	15:10
	R2-1-90gpm	At 2.5mg-N/L	15:23
	R2-2-90gpm	At 0.5mg-N/L	15:34
	R2-3-90gpm	Below detection (lowest value)	15:40
	R2-4-90gpm	5 minutes after sample #3	15:45
	R2-5-90gpm	10 minutes after sample #3	15:50
	R2-6-90gpm	20 minutes after sample #3	16:00

Table 5 MBfR1 (R1) Batch Test Sample Collection Times, Day 2

Recirculation Rate (gpm)	Sample	Sample Collection Trigger	Time
MBfR1: 150 MBfR2: 180	Initial Reading	5.2 mg-N/L	9:57
	R1-0-150gpm	At 5.0mg-N/L	9:58
	R1-1-150gpm	At 2.5mg-N/L	10:12
	R1-2-150gpm	At 0.5mg-N/L	10:25
	R1-3-150gpm	Below detection (lowest value)	10:32
	R1-4-150gpm	5 minutes after sample #3	10:37
	R1-5-150gpm	10 minutes after sample #3	10:42
	R1-6-150gpm	20 minutes after sample #3	10:52
MBfR1:50 MBfR2: 180	Initial Reading	5.5 mg-N/L	11:04
	R1-0-50gpm	At 5.0mg-N/L	11:05
	R1-1-50gpm	At 2.0mg-N/L	11:23
	R1-2-50gpm	At 0.5mg-N/L	11:40
	R1-3-50gpm	Below detection (lowest value)	11:56
	R1-4-50gpm	5 minutes after sample #3	12:01
	R1-5-50gpm	10 minutes after sample #3	12:06
	R1-6-50gpm	20 minutes after sample #3	12:16
MBfR1: 100 MBfR2: 180	Initial Reading	5.23 mg-N/L	13:06
	R1-0-100gpm	At 5.0mg-N/L	13:07
	R1-1-100gpm	At 2.5mg-N/L	13:23
	R1-2-100gpm	At 0.5mg-N/L	13:36
	R1-3-100gpm	Below detection (lowest value)	13:45
	R1-4-100gpm	5 minutes after sample #3	13:50
	R1-5-100gpm	10 minutes after sample #3	13:55
	R1-6-100gpm	20 minutes after sample #3	13:05
MBfR1: 200 MBfR2: 180	Initial Reading	5.2 mg-N/L	14:42
	R1-0-200gpm	At 5.0mg-N/L	14:43
	R1-1-200gpm	At 2.5mg-N/L	14:53
	R1-2-200gpm	At 0.5mg-N/L	15:07
	R1-3-200gpm	Below detection (lowest value)	15:13
	R1-4-200gpm	5 minutes after sample #3	15:18
	R1-5-200gpm	10 minutes after sample #3	15:23
	R1-6-200gpm	20 minutes after sample #3	15:33

3.0 MBfR SPARGE SAMPLING PROCEDURE

Rialto ARo-Perc Sparge Process Sampling Procedure

Scope The following procedure is to be used by Rialto personnel whenever Rialto MBfR sparge process is initiated.

Attributes and Categories

Categories
 Critical Emergency Operating Other _____

Attributes (Operating/Other)
 Routine Non-Routine

Hazards and Precautions

The table below lists job hazards associated with completing this procedure and the precautions that should be taken for safety, environmental, quality, ergonomics, Good Manufacturing Practices, etc. before beginning this procedure.

Hazard	Precaution
Leakage.	Ensure all pipe connections are properly secured, and monitor all draining activities.
Pressurized water coming in contact with operator when taking sample.	Wear eye protection, gloves, and protective clothing.

Tools and Equipment

Listed below are the unique tools and equipment needed to do this job.

Tool/Equipment	Use
Sample bottles.	Collecting water sample.
Test kit.	Testing for solids.

Consequences of Deviation If this procedure is not followed, missing or inaccurate data could occur. This table lists consequences of deviation from the procedure steps or general operating limits.

Type of Deviation	Consequences and How to Avoid
Sample not taken at the right time.	Inaccurate data collected will lead to inaccurate results. Would require another sample to be taken, wasting time and money. Make sure to follow the steps during the sparge process.

Sampling

Step	Action																
1	Consult with APT water to determine when operating personnel should be present to take sample.																
2	From the Main Menu, go to the “Sparge” screen on the OIT. Prepare to take sample from LAG reactor.																
3	<p>Sparge process for the lag reactor will go through the following steps:</p> <table border="0" data-bbox="573 489 1406 831"> <tr> <td>Step:</td> <td>Approx. duration time (min)*:</td> </tr> <tr> <td>1 Pumpout</td> <td>1-5</td> </tr> <tr> <td>2 Sparge</td> <td>1</td> </tr> <tr> <td>3 Drain</td> <td>3-5</td> </tr> <tr> <td>4 Fill Heel</td> <td>1-3</td> </tr> <tr> <td>5 Recirc</td> <td>1</td> </tr> <tr> <td>6 Drain Heel</td> <td>2-4</td> </tr> <tr> <td>7 Equalize</td> <td>4-5</td> </tr> </table> <p>8 Refill - -will happen simultaneously with sparge process of lead reactor.</p> <p>These steps will be shown in the OIT screen during the sparge process with the current step being highlighted.</p> <p>*These are just estimates and the actual duration time could be different. Therefore, it is recommended to keep track of steps in the OIT screen.</p>	Step:	Approx. duration time (min)*:	1 Pumpout	1-5	2 Sparge	1	3 Drain	3-5	4 Fill Heel	1-3	5 Recirc	1	6 Drain Heel	2-4	7 Equalize	4-5
Step:	Approx. duration time (min)*:																
1 Pumpout	1-5																
2 Sparge	1																
3 Drain	3-5																
4 Fill Heel	1-3																
5 Recirc	1																
6 Drain Heel	2-4																
7 Equalize	4-5																
4	Drain step (#3) will be highlighted after Sparge step (#2) is completed. Listen for the drain pump turning on to make sure step 3 has started and prepare to take sample. It is recommended to collect three samples of ~333mL each at 0.5, 1.5, and 2.5 minutes. Purge first ~200ml from SP-600 (located after the drain pump) before taking first sample and then start collecting approximately 1L for analysis at the given times. Label sample as “Lag First Drain.”																
5	Once the Drain step is completed (drain pump will turn off), the tank will be partially filled and then recirculated. This will help remove anything that didn’t get removed during the first drain process from the lag vessel.																
6	Drain Heel step (#6) will start following recirculation and will be highlighted in the OIT screen. Listen for the drain pump turning on and proceed to collect three samples of ~333mL each at 0.5, 1.5, and 2.5 minutes. Purge first ~200ml from SP-600 before taking first sample and then start collecting approximately 1L for analysis at the given times. Label sample as “Lag Second Drain.”																

7	<p>After the Equalized step for lag reactor is completed, sparge process will start for the lead reactor and will go through the following steps:</p> <table style="width: 100%; border-collapse: collapse;"> <tr> <td style="width: 60%;">Step:</td> <td style="text-align: right;">Approx. duration time (min)*:</td> </tr> <tr> <td>1 Pumpout</td> <td style="text-align: right;">1-5</td> </tr> <tr> <td>2 Sparge</td> <td style="text-align: right;">1</td> </tr> <tr> <td>3 Drain</td> <td style="text-align: right;">3-5</td> </tr> <tr> <td>4 Fill Heel</td> <td style="text-align: right;">1-3</td> </tr> <tr> <td>5 Recirc</td> <td style="text-align: right;">1</td> </tr> <tr> <td>6 Drain Heel</td> <td style="text-align: right;">2-4</td> </tr> <tr> <td>7 Refill</td> <td style="text-align: right;">20</td> </tr> </table> <p>These steps will be shown in the OIT screen during the sparge process with the current step being highlighted.</p> <p>*These are just estimates and the actual duration time could be different. Therefore, it is recommended to keep track of steps in the OIT screen.</p>	Step:	Approx. duration time (min)*:	1 Pumpout	1-5	2 Sparge	1	3 Drain	3-5	4 Fill Heel	1-3	5 Recirc	1	6 Drain Heel	2-4	7 Refill	20
Step:	Approx. duration time (min)*:																
1 Pumpout	1-5																
2 Sparge	1																
3 Drain	3-5																
4 Fill Heel	1-3																
5 Recirc	1																
6 Drain Heel	2-4																
7 Refill	20																
8	<p>Drain step (#3) will be highlighted after Sparge step (#2) is completed. Listen for the drain pump turning on to make sure step 3 has started and prepare to take sample. It is recommended to collect three samples of ~333mL each at 0.5, 1.5, and 2.5 minutes. Purge first ~200ml from SP-600 (located after the drain pump) before taking first sample and then start collecting approximately 1L for analysis at the given times. Label sample as "Lead First Drain."</p>																
9	<p>After the Drain step, the tank will be partially filled and then recirculated. This will help remove anything that didn't get removed during the first drain process from the lead vessel.</p>																
10	<p>Drain Heel step (#6) will start following recirculation and will be highlighted in the OIT screen. Listen for the drain pump turning on and proceed to collect three samples of ~333mL each at 0.5, 1.5, and 2.5 minutes. Purge first ~200ml from SP-600 before taking first sample and then start collecting approximately 1L for analysis at the given times. Label sample as "Lead Second Drain."</p>																
11	<p>After the Refill step (#7) is completed, the feed water is stopped until the nitrate levels have been reduced to <1mg-N/L.</p>																

Revision History

The following table lists all changes made to this document.

Date	Revised By	Changes
6/15/11	Renato Vigo	Document created.
8/8/11	Renato Vigo	Modified to include better duration times for sparge steps.

4.0 MEDIA FILTER SAMPLING PROCEDURE

Rialto Filter Backwash Sampling Procedure

Scope

The following procedure is to be used by Rialto personnel whenever Rialto media filter backwash is initiated.

Attributes and Categories

Categories

Critical Emergency Operating Other _____

Attributes (Operating/Other)

Routine Non-Routine

Hazards and Precautions

The table below lists job hazards associated with completing this procedure and the precautions that should be taken for safety, environmental, quality, ergonomics, Good Manufacturing Practices, etc. before beginning this procedure.

Hazard	Precaution
Leakage.	Ensure all pipe connections are properly secured, and monitor all backwash activities.
Pressurized water coming in contact with operator when taking sample.	Wear eye protection, gloves, and protective clothing.
Falling off from a ladder.	Refer to the manufacturer's instructions to avoid falling off from a ladder.

Tools and Equipment

Listed below are the unique tools and equipment needed to do this job.

Tool/Equipment	Use
Sample bottles.	Collecting water sample.
Test kit.	Testing for total solids and turbidity.
6 foot Ladder.	Monitoring the backwash from the top of the media filter.

Consequences of Deviation

If this procedure is not followed, missing or inaccurate data could occur. This table lists consequences of deviation from the procedure steps or general operating limits.

Type of Deviation	Consequences and How to Avoid
-------------------	-------------------------------

Sample not taken at the right time.	Inaccurate data collected will lead to inaccurate results. Would require another sample to be taken, wasting time and money. Make sure to follow the steps during the media filter backwash.
-------------------------------------	--

Procedure

Step	Action										
1	Consult with APT water to determine when operating personnel should be present to take sample.										
2	<p>Initiate Media Filter backwash.</p> <ul style="list-style-type: none"> From the Main Menu, go to the “Filtration Overview” screen. Change the “dP to Initiate Backwash” value to a number less than the “Filter dP” value. After 60 seconds, the “Filter Backwash Trigger” will read ON and shortly after that Backwash pump (P-514) will turn on and water from the product tank will start flowing backwards through the filter. P-514 will stay on during the entire backwash process and will turn off 20 min 40 sec after backwash process is initiated. The lower right corner of the “Filtration Overview” screen will change from “NOT Backwashing” to “Backwashing.” 										
3	<p>Backwash process for the media filter will go through the following steps:</p> <table border="0"> <tr> <td>Step:</td> <td>Approx. duration time (min)*:</td> </tr> <tr> <td>1 Backwash</td> <td>10-13</td> </tr> <tr> <td>2Settle</td> <td>1-1.5</td> </tr> <tr> <td>3Purge</td> <td>3.5-4</td> </tr> <tr> <td>4Start next</td> <td>0.5-1</td> </tr> </table> <p>*These are just estimates and the actual duration time could be different.</p>	Step:	Approx. duration time (min)*:	1 Backwash	10-13	2Settle	1-1.5	3Purge	3.5-4	4Start next	0.5-1
Step:	Approx. duration time (min)*:										
1 Backwash	10-13										
2Settle	1-1.5										
3Purge	3.5-4										
4Start next	0.5-1										
4	<p>Using the 6 foot ladder, monitor the backwash process from the top of the filter: an arrow on the Hydrus valve will point to the current step and will move clockwise from one step to the next.</p>  <p>Figure 1. Top view of the Hydrus valve located on the top of the Filter.</p>										

5	<p>Take sample from SP-506 during the Backwash step (#1):</p> <ul style="list-style-type: none"> The entire Backwash process will use 400-500 gallons of water and the initial volume concentration may not be equal the final volume concentration; therefore, it is recommended to collect five samples of ~200mL each at 1, 3,5,7, and 9 minutes after step 1 begins. Purge and then collect samples. Use all samples taken to make a composite sample of about 1Liter for analysis.
6	<p>Regardless of the current step, P-514 will always be on during the entire Backwash process and will try to achieve a Filter Outlet pressure equal to the setpoint (i.e. 30psig). You can access this by going to the “Filter BW Pressure PID” screen from the Main Menu or by pushing the filter outlet pressure button directly from the “Filtration Overview” screen. This pressure may not be possible to reach if a process valve is not throttled in the field.</p>
7	<p>During the Settle step (#2) nothing will be flowing through the filter (internal filter media valve will close). P-514’s speed will adjust (slow down) to reach the pressure equal to that of the step point during this step.</p>
8	<p>Water will flow through the filter during the Purge step (#3) (internal filter media valve will open).</p>
9	<p>P-514 is programmed to run for 20min and 40 seconds after the backwash process is initiated. This should be enough time for the backwash valve to cycle through completely.</p>

Revision History

The following table lists all changes made to this document.

Date	Revised By	Changes
6/29/11	Renato Vigo	Document created. Approved by:

APPENDIX E

QUALITY ASSURANCE AND QUALITY CONTROL

1.0 METHODS

Quality assurance (QA) and quality control (QC) samples were analyzed to provide site-specific, field-originated information to assess whether data were of defensible quality as determined by adherence to the project's QA/QC requirements outlined in the Quality Assurance Project Plan (QAPP). QA/QC samples were collected concurrently with field samples and equally represented the medium being sampled at a given time and location. The following QA/QC samples were collected:

- Field Duplicates
- Matrix Spike/Matrix Spike Duplicates
- Trip Blanks

1.1 FIELD DUPLICATES

Field duplicate samples were collected to aid evaluation of the homogeneity of the sample matrix and the consistency of the sampling effort. Field duplicates also provided an assessment of precision including sampling and handling error. Field duplicates were collected at a frequency of approximately one field duplicate sample per 10 samples collected. Field duplicates were collected concurrently with the primary environmental samples and equally represented the medium at a given time and location.

The precision goal for sample pairs whose values were greater than 10 times the practical quantitation limit (PQL) was a relative percent deviation (RPD) of less than or equal to 25 percent (%). For sample pairs that had one or both values less than 10 times the PQL, the precision goal was an RPD of less than or equal to 50%. Sample pairs that had one or both values that were less than the PQL had no RPDs calculated. If the precision goals were not met for any given sampling round, the project manager and field team leader performed a review of sample collection and handling procedures. For analyses performed in the field, the field procedures were also reviewed.

1.2 MATRIX SPIKE/MATRIX SPIKE DUPLICATES

Matrix spike/matrix spike duplicate (MS/MSD) samples assess laboratory instrument accuracy and the matrix effects on the results. Specific samples for MS/MSD analysis were not collected for this project; instead, MS/MSDs were included with each sample run and included in the analytical laboratory's report. The frequency of MS/MSD analysis was approximately one in 20 samples. The only parameters that required matrix spikes were the volatile organic compound (VOC) and perchlorate samples analyzed by an offsite laboratory. The accuracy goal for these samples was a percent recovery of 70-130%.

1.3 TRIP BLANKS

Trip blanks provide an assessment of VOC cross-contamination during sample handling and shipment to the off-site laboratory. Trip blank samples were collected with each cooler containing samples for VOC analysis starting in the Optimization phase. The accuracy goal for all trip blanks was no detections of analytes in these samples. The lab was instructed to hold trip blanks until VOC analyses were complete and data were validated. If questionable analytical results were obtained, then the trip blanks were run to determine if possible contamination existed. However, there were no questionable results during the project so no trip blanks were analyzed during the project.

2.0 CALIBRATION PROCEDURES

Calibration procedures followed procedures outlined in the QAPP and manufacturer's specifications. Laboratory analytical calibration procedures were conducted in accordance with the QAPP and the laboratory's QA manual.

2.1 WATER MONITORING INSTRUMENTS

Field instruments were calibrated in the field at the beginning of each day (see Appendix D for records). Field water monitoring instruments included a Hach 2100N turbidity meter and Oakton pH, temperature, and ORP probe. Standards used for pH calibration included Oakton 4.0, 7.0 and 10.0 standard unit solutions. Standards used for the turbidity meter calibration included Hach 0, 20, 200, 1000 and 4000 Nephelometric Turbidity Units (NTU) high range standards, and Hach 0.136, 0.300, and 0.500 NTU low range standards were used for verification.

2.2 AIR MONITORING INSTRUMENTS

Air quality monitoring was warranted when an odor of hydrogen sulfide was detected during Steady State operations. Two four-gas meters were used during the study, one was a Scientific Instruments gas meter and the other an Equipco QREA. The four-gas meters were calibrated at the beginning of each field day where air monitoring took place. Standards used for calibration included a mixed cylinder containing 50.0% carbon monoxide, 12.5% oxygen, 50.0% methane, and 25% hydrogen sulfide. See Appendix D for calibration records.

2.3 SYSTEM MONITORING EQUIPMENT

The Operator Interface Terminal (OIT) data displayed monitoring information from online sensors at the site, and these data were also available for remote monitoring through an internet web address. Equipment which required regular calibration and maintenance is shown in Table 1. A full description of equipment operations and maintenance is included in Appendix G, the O&M Manual.

Table 1 Field Equipment Inspection and Calibration Frequency

Equipment	Manufacturer	Function	Frequency
Mass flow meter	MKS Instruments	Chemical gas flow rate	As needed
Pressure gauge	--	Chemical gas pressure	As needed
Magnetic flow meter	Signet	Water flow rate	Quarterly
Pressure gauge	--	Water pressure	As needed
Level sensor	Warrick	Tank Water level	As needed
Dryloc pH probe	Signet	pH	1-4 weeks
Dryloc Oxidation reduction potential (ORP) probe	Signet	ORP	1-4 weeks
Turbidity Sensor	TurbiMax	Turbidity	Quarterly
Nitrate Analyzer	Stamosens	Nitrate concentration	Monthly
Lower explosive limit (LEL) detector		LEL	Quarterly

3.0 RESULTS

A total of 2,350 analyses were performed during the demonstration, and 201 field duplicate samples were collected and evaluated for precision and accuracy (Table 2). The field duplicate rate of sample collection was slightly lower than planned at 9%. The average RPD for heterotrophic plate counts (HPCs) was 118%, which exceeded the RPD threshold of 25%. Of the six field duplicate samples tested, three had considerably high RPDs of 184, 174, and 114% (these samples were above 10 times the PQL). While this did not meet the data usability objective, HPC is a bioassay and as such is notorious for having a high degree of variability between samples. Results for HPCs are generally interpreted with order of magnitude differences being significant because of this difficulty.

Remaining samples had average RPDs below threshold values for usability. While the average RPD for DOC was below the threshold, there was one field duplicate with an RPD of 63%; this sample had a very low concentration near the PQL (1.1 vs 0.57 mg/L with a PQL of 1 mg/L). Two TCE sample results were above the threshold for data usability with an RPD of 76 and 79%, respectively. Similarly, these samples had low concentrations. Total suspended solids had RPDs which exceeded the data quality threshold of 50% in three samples. Two of the samples had RPDs of 58 and 67%, respectively. In each of these cases, the measurements were either at or as much as 10% less than the PQL. The remaining sample had an RPD of 156%, but again these results were very close to the PQL (4.8 and 0.6 mg/L with a PQL of 1.0 mg/L).

MS/MSDs were only required for VOCs and perchlorate with an accuracy goal of 70-130% recovery. The percent recovery of perchlorate samples averaged 103%. The percent recovery for the VOC samples including TCE, cis-1,2 dichloroethene and vinyl chloride was 94%, 105% and 93% respectively. The analytical laboratory performed MS/MSDs for several other parameters as part of their laboratory QA program. No samples exceeded the percent recovery thresholds for data quality (Table 2).

Table 2 Data Quality Indicators

Analyte	No. Field Samples	No. Field Duplicates	Average RPD	No. MS/MSDs	Average Percent Recovery (%)
Perchlorate	404	44	8%	20	103%
Perchlorate (confirmatory)	63	4	3%	3	83%
Nitrate	168	17	7%	8	97%
Nitrite	167	17	6%	8	101%
Total suspended solids	63	7	40%	5	82% ²
Threshold odor number	17	1	0%	1	94% ²
Fecal coliforms	100	6	0%	5	83% ²
Total coliforms	100	6	0%	5	89% ²
E coli	36	4	0%	2	86% ²
Heterotrophic plate count	90	6	118%	5	78% ²
DOC	119	8	18%	6	100%
TCE	168	14	15%	9	94%
cis-1,2-DCE	166	14	0%	8	105%
VC	113	14	0%	6	93%
TTHMs	20	3	3%	1	127%
Sulfate	46	4	2%	2	100%
Total sulfide	125	4	10%	6	84%
Alkalinity	83	7	3%	4	110% ²
Total dissolved solids	90	7	2%	4	93% ²
Haloacetic acids	38	3	1%	2	108%
Phosphate	27	2	18%	1	116%
Ammonia	41	4	30%	2	109%
Hardness	82	7	1%	4	91% ²
N-Nitrosodiethylamine	6	0	-- ¹	1	106% ²
N-Nitrosodimethylamine	6	0	-- ¹	1	95.5% ²
N-Nitroso-di-n-propylamine	6	0	-- ¹	1	92.5% ²
TTHM-FP	12	0	-- ¹	1	-- ¹
Turbidity	4	0	-- ¹	1	101% ²

Notes: ¹ not determined.

² MS/MSD sample results were not from the current study but were included in the analytical report for samples analyzed with the same batch that day.

Completeness of data was assessed as the percentage of valid samples that met precision and accuracy requirements compared to the total number of samples. The completeness goal for this project was 90%, as defined in the Demonstration Plan QAPP. Completeness was tracked both for individual sampling rounds and cumulatively over the course of the demonstration. Completeness was >99%, as only two samples were not useable due to holding time exceedances. There were two samples that exceeded the holding time for nitrate. These samples were collected during the Challenge phase on January 12, 2012. The samples were collected from the finished water, one was a field duplicate. The samples were eliminated from further

analysis. While there were some data points that exceeded the accuracy data quality objective for HPCs, the samples were included with the understanding that HPC is an inherently difficult test to reproduce and at most order of magnitude changes should be assessed to determine differences.

APPENDIX F
LABORATORY ANALYTICAL DATA

Date	MBfR Influent																									
	Time	Target Flow Rate	Perchlorate EPA Method 314.0	Perchlorate EPA Method 332.0	Nitrate	Nitrite	Nitrate+Nitrite	Ammonia	DOC	TCE	cis 1,2-DCE	VC	Acetone	Sulfate	Alkalinity	TDS	Turbidity	TTHMs	TTHM-Formation Potential	HAA5	HAA6	Phosphate	Hardness			
	days	gpm	µg/L		mg/L-N	mg/L-N	mg/L-N	mg/L-N	mg/L	µg/L	µg/L	µg/L	µg/L	mg/L	mg/L	mg/L	NTU	µg/L		µg/L	µg/L	mg/L	mg/L			
4/22/2011	-6	0	180		8.8	0.15	U	8.95															< 0.16			
4/25/2011	-3	0																								
4/27/2011	-1	0																								
4/29/2011	1	5	180		8.8	0.15	U	8.95			55	1	U	0.5	U	5.3								200		
5/2/2011	4	5	180																					0.14		
5/4/2011	6	5	180																							
5/6/2011	8	5	190		8.4	0.15	U	8.55			50	1	U	0.5	U		21	160	250					200		
5/9/2011	11	5	180																							
5/11/2011	13	5	210		8.3	0.15	U	8.45			65	1	U	0.5	U		20	150	240					190		
5/13/2011	15	8	190																							
5/16/2011	18	10	170																							
5/18/2011	20	10	190		8.7	0.15	U	8.85		1	U	53	1	U	0.5	U		20	150	250				0.16	U	190
5/20/2011	22	10	180																					0.16	U	
5/23/2011	25	8	170																							
5/25/2011	27	8	180		8.3	0.15	U	8.45		1.1	56	1	U	0.5	U		20	140	260					0.16	U	200
5/27/2011	29	8	180																					0.16	U	
6/1/2011	34	10	180																							
6/3/2011	36	10	200		8.1	0.15	U	8.25		1	U	56	1	U	0.5	U		21	140	270				0.16	U	210
6/6/2011	39	12																						0.25		
6/10/2011	43	12	180																							
6/13/2011	46	12	190																							
6/16/2011	49	12																								
6/20/2011	53	12	190		8.3	0.15	U	8.45	0.5	U	0.27	44	1	U	0.5	U	10	U	20	160	250			0.16	U	200
6/27/2011	60	12	170		8.6	0.15	U	8.75																		
7/5/2011	68	16	180		8.3	0.15	U	8.45	0.5	U	0.092	58	1	U	0.5	U	10	U	20	180	270			0.16	U	200
7/11/2011	74	16	190		8.3	0.15	U	8.45	0.5	U	0.084	51	1	U	0.5	U			21	140	260			0.16	U	190
7/18/2011	81	10																								
7/25/2011	88	20	180		8.0	0.15	U	8.15				53	1	U	0.5	U	10	U	21	150	270			0.14	U	
8/1/2011	95	22	170		8.4	0.15	U	8.55	0.14		0.17	58	< 1		0.5	U			20	160	260			0.16	U	190
8/8/2011	102	20	180																							
8/15/2011	109	18	180		9	0.15	U	9.15	0.5	U	0.31	59	< 1		0.5	U			21	160	270			0.16	U	190
8/17/2011	111	18	200																							

Date	MBfR Influent																													
	Time	Target Flow Rate	Perchlorate EPA Method 314.0	Perchlorate EPA Method 332.0	Nitrate	Nitrite	Nitrate+Nitrite	Ammonia	DOC	TCE	cis 1,2-DCE	VC	Acetone	Sulfate	Alkalinity	TDS	Turbidity	TTHMs	TTHM-Formation Potential	HAA5	HAA6	Phosphate	Hardness							
	days	gpm	µg/L		mg/L-N	mg/L-N	mg/L-N	mg/L-N	mg/L	µg/L	µg/L	µg/L	µg/L	mg/L	mg/L	mg/L	NTU	µg/L		µg/L	µg/L	mg/L	mg/L							
8/19/2011	113	18	170																											
8/26/2011	120	15	160	130	9	0.15	U	9.15	0.5	U	0.6	65	1	U	0.5	U	10	U	22	160	250		190							
8/31/2011	125	15	170																											
9/2/2011	127	15	170																											
9/7/2011	132	15	160	160	9.3	0.15	U	9.3	0.5	U	1	54	1	U	0.5	U	10	U	21	140	280		190							
9/9/2011	134	10	160																											
9/12/2011	137	10	160	160	9.2	0.15	U	9.2	1.5		0.21	64	1	U	0.5	U	10	U	21	140	280		190							
9/14/2011	139	10	170																											
9/16/2011	141	20	170																											
9/19/2011	144	5	180		9.7	0.15	U	9.7																						
10/3/2011	158	10	160		8.8	0.15	U	8.8																						
10/5/2011	160	10	150	160	8.6	0.15	U	8.6	0.5	U	1.1	59	1	U	0.5	U		21	150	260			190							
10/7/2011	162	10	160																											
10/10/2011	165	5	160																											
10/12/2011	167	5	150																											
10/14/2011	169	5	160																											
10/17/2011	172	10	160	170	8.7	0.15	U	8.7	0.5	U	0.51	55	1	U	0.5	U		21	130	250			190							
10/19/2011	174	10	160																											
10/21/2011	176	10	140																											
10/26/2011	181	10	160	150	9	0.15	U	9	0.5	U	0.29	39	1	U	0.5	U	10	U	22	150	260		210							
10/28/2011	183	10	160																											
10/31/2011	186	10	120																											
11/2/2011	188	10	150	150	9	0.15	U	9	0.5	U	0.6	54	1	U	1	U	10	U	21	160	270		180							
11/4/2011	190	10	160																											
11/7/2011	193	10	160																											
11/9/2011	195	10	140	130	8.9	0.15	U	8.9	0.5	U	0.69	63	1	U	0.5	U		22	140	270			190							
11/11/2011	197	10	130																											
11/16/2011	202	10																												
11/18/2011	204	10	160	140	9	0.15	U	9	0.12		0.13	43	1	U	0.5	U		22	160	250			200							
11/22/2011	208	10	150	130	9.2	0.15	U	9.2	0.5	U	0.97	51	1	U	0.5	U		22	130	260			190							
11/28/2011	214	8	160		8.4	0.15	U	8.4	0.5	U	2.0	48	1	U	0.5	U	10	U	22	150	260		4	U	6	U	7	U		200
11/30/2011	216	8	140																											

Date	Time	Target Flow Rate	MBfR Influent																										
			Perchlorate EPA Method 314.0	Perchlorate EPA Method 332.0	Nitrate	Nitrite	Nitrate+Nitrite	Ammonia	DOC	TCE	cis 1,2-DCE	VC	Acetone	Sulfate	Alkalinity	TDS	Turbidity	TTHMs	TTHM-Formation Potential	HAA5	HAA6	Phosphate	Hardness						
			µg/L		mg/L-N	mg/L-N	mg/L-N	mg/L-N	mg/L	µg/L	µg/L	µg/L	µg/L	mg/L	mg/L	mg/L	NTU	µg/L		µg/L	µg/L	mg/L	mg/L						
12/9/2011	225	6																											
12/14/2011	230	6	150																										
12/16/2011	232	6	160		9.3	0.15	U	9.3	0.14		2	58	1	U	0.5	U		23		270		8.6	6	U	7	U		190	
12/19/2011	235	6	160		9.2	0.15	U	9.2	0.5	U	2.1	57	1	U	0.5	U		22	150	250			6	U	7	U		200	
12/21/2011	237	6	150																										
12/23/2011	239	6	150																										
12/27/2011	243	6	160		8.9	0.15	U	8.9	0.37		1.1	39	1	U	0.5	U	10	U	22	150	220			6	U	7	U		190
12/28/2011	244	6	150																										
12/30/2011	246	6	160																										
1/3/2012	250	6	150		8.3	0.15	U	8.3	0.5	U	0.79	51	1	U	0.5	U		22	140	280			19		19			200	
1/4/2012	251	6	150																										
1/6/2012	253	6	160																										
1/9/2012	256	6	150		9.2	0.15	U	9.2	0.5	U	0.14	60	1	U	0.5	U		22	140	300								210	
1/11/2012	258	6	160																										
1/12/2012	259	6																											
1/13/2012	260	6																											
1/17/2012	264	6																											
1/18/2012	265	6																											
1/20/2012	267	6																											
1/23/2012	270	6																											
1/25/2012	272	6																											

Date	Time	Target Flow Rate	Strainer		Lead Reactor													
			Phosphate	Perchlorate EPA Method 314.0	Perchlorate EPA Method 332.0	Nitrate	Nitrite	Nitrate+Nitrite	Total Sulfide	TCE	cis 1,2-DCE	VC	Alkalinity	TDS	Hardness			
			mg/L	µg/L	µg/L	mg/L-N	mg/L-N	mg/L-N	mg/L	µg/L	µg/L	µg/L	mg/L	mg/L	mg/L			
4/22/2011	-6	0		180	190	8.9	0.15	U	9.05									
4/25/2011	-3	0		190														
4/27/2011	-1	0		3.1														
4/29/2011	1	5		180		8.6	0.15	U	8.75		34	1	U	0.5	U	180	260	200
5/2/2011	4	5		180														
5/4/2011	6	5		150														
5/6/2011	8	5		120		2.9	0.15	U	3.05		38	1	U	0.5	U	190	230	200
5/9/2011	11	5		41														
5/11/2011	13	5		140		2.3	0.15	U	2.45		48	1	U	0.5	U	170	240	200
5/13/2011	15	8		180														
5/16/2011	18	10		150														
5/18/2011	20	10		180		3.5	3.2		6.7		40	1	U	0.5	U	150	240	190
5/20/2011	22	10		170														
5/23/2011	25	8		170														
5/25/2011	27	8		190		3.4	2.5		5.9		53	1	U	0.5	U	160	260	200
5/27/2011	29	8		200														
6/1/2011	34	10		170														
6/3/2011	36	10		190		3.8	1.5		5.3		42	1	U	0.5	U	160	260	210
6/6/2011	39	12																
6/10/2011	43	12		190														
6/13/2011	46	12		200														
6/16/2011	49	12		180		4.4	1.6		6									
6/20/2011	53	12		190		2.7	3		5.7		48	1	U	0.5	U	170	240	200
6/27/2011	60	12		170		2	3.9		5.9									
7/5/2011	68	16		180		4.1	2.8		6.9		47	1	U	0.5	U	180	260	200
7/11/2011	74	16		180		4.4	2.3		6.7		44	1	U	0.5	U	160	260	190
7/18/2011	81	10																
7/25/2011	88	20		140		1.8	2.0		3.8							170	240	
8/1/2011	95	22		140		1.3	1.5		2.8		42	1	U	0.5	U	190	260	190
8/8/2011	102	20		130						0.023								
8/15/2011	109	18		110		2.3	0.75		3.05		53	1	U	0.5	U	170	260	180
8/17/2011	111	18		110														

Date	Time	Target Flow Rate	Strainer	Lead Reactor													
			Phosphate	Perchlorate EPA Method 314.0	Perchlorate EPA Method 332.0	Nitrate	Nitrite	Nitrate+Nitrite	Total Sulfide	TCE	cis 1,2-DCE	VC	Alkalinity	TDS	Hardness		
			mg/L	µg/L	µg/L	mg/L-N	mg/L-N	mg/L-N	mg/L	µg/L	µg/L	µg/L	mg/L	mg/L	mg/L		
8/19/2011	113	18		150													
8/26/2011	120	15		61	70	2	0.73	2.73		60	1	U	0.5	U	170	230	190
8/31/2011	125	15		57													
9/2/2011	127	15		76													
9/7/2011	132	15	0.21	110	100	3	1	4		50	1	U	0.5	U	170	270	200
9/9/2011	134	10	0.46	65													
9/12/2011	137	10	0.23	47	39	1.2	0.52	1.72		58	1	U	0.5	U	160	260	180
9/14/2011	139	10		69													
9/16/2011	141	20		99													
9/19/2011	144	5		13		0.44	0.15	U 0.59									
10/3/2011	158	10		130		3.4	1.9	5.3									
10/5/2011	160	10	0.35	94	80	1	1	2		49	1	U	0.5	U	180	250	190
10/7/2011	162	10		39													
10/10/2011	165	5		7		0.16	0.15	0.31									
10/12/2011	167	5		12													
10/14/2011	169	5		8.1													
10/17/2011	172	10	0.16	150	140	3.7	1.9	5.6		54	1	U	0.5	U	160	250	200
10/19/2011	174	10		110													
10/21/2011	176	10		130													
10/26/2011	181	10	0.33	110	99	1	2.1	3.1		55	1	U	0.5	U	170	240	210
10/28/2011	183	10		130													
10/31/2011	186	10		80													
11/2/2011	188	10	0.16	44	45	0.48	0.68	1.16		49	1	U	1	U	190	240	180
11/4/2011	190	10		47													
11/7/2011	193	10		42													
11/9/2011	195	10	0.26	31	32	0.57	0.65	1.22		52	1	U	0.5	U	170	260	200
11/11/2011	197	10		31													
11/16/2011	202	10															
11/18/2011	204	10	0.34	50	49	0.88	0.74	1.62		42	1	U	0.5	U	170	240	210
11/22/2011	208	10		80	72	0.97	1.5	2.47		46	1	U	0.5	U	160	240	190
11/28/2011	214	8	0.36	78		1.1	1.4	2.5		46	1	U	0.5	U	170	240	200
11/30/2011	216	8		61													

Date	Time	Target Flow Rate	Strainer	Lead Reactor													
			Phosphate	Perchlorate EPA Method 314.0	Perchlorate EPA Method 332.0	Nitrate	Nitrite	Nitrate+Nitrite	Total Sulfide	TCE	cis 1,2-DCE	VC	Alkalinity	TDS	Hardness		
			mg/L	µg/L	µg/L	mg/L-N	mg/L-N	mg/L-N	mg/L	µg/L	µg/L	µg/L	mg/L	mg/L	mg/L		
12/9/2011	225	6															
12/14/2011	230	6		56													
12/16/2011	232	6	0.49	62		1.2	0.72	1.92		53	1	U	0.5	U	34	250	180
12/19/2011	235	6		55		1.1	0.92	2.02		46	1	U	0.5	U	160	240	190
12/21/2011	237	6		58													
12/23/2011	239	6		56													
12/27/2011	243	6	0.43	56		1	0.84	1.84		45	1	U	0.5	U	170	240	190
12/28/2011	244	6		47													
12/30/2011	246	6		49													
1/3/2012	250	6	0.83	45		0.86	1.1	1.96		46	1	U	0.5	U	180	270	210
1/4/2012	251	6		40													
1/6/2012	253	6		59													
1/9/2012	256	6	0.54	50		0.87	0.74	1.61		43	1	U	0.5	U	180	280	210
1/11/2012	258	6		99													
1/12/2012	259	6															
1/13/2012	260	6															
1/17/2012	264	6															
1/18/2012	265	6															
1/20/2012	267	6															
1/23/2012	270	6															
1/25/2012	272	6															

Date	Time	Target Flow Rate	Lag Reactor																											
			Perchlorate EPA Method 314.0	Perchlorate EPA Method 332.0	Ammonia	Nitrate	Nitrite	Nitrate+Nitrite	Fecal Coliforms	Total Coliforms	E. coli	Plate Count	DOC	TCE	cis 1,2-DCE	VC	Sulfide	Alkalinity	TDS	Turbidity	Hardness									
			µg/L	µg/L	mg/L-N	mg/L-N	mg/L-N	mg/L-N	MPN/100 ml	MPN/100 ml	MPN/100 mL	CFU/ml	mg/L	µg/L	µg/L	µg/L	µg/L	mg/L	mg/L	NTU	mg/L									
4/22/2011	-6	0	180			8.6	0.15	U	8.75																					
4/25/2011	-3	0	150																											
4/27/2011	-1	0	120																											
4/29/2011	1	5	180	190		7.3	0.15	U	7.45						29	1	U	0.5	U		170	260	200							
5/2/2011	4	5	150																											
5/4/2011	6	5	14	12																										
5/6/2011	8	5	4.5	5		0.11	U	0.15	U	0.26	U	2	U	7		2	U	1	U	32	1	U	0.5	U		200	230	200		
5/9/2011	11	5	5.9																											
5/11/2011	13	5	16	18		0.1		0.15	U	0.25		2	U	8			1	U	44	1	U	0.5	U		180	230	190			
5/13/2011	15	8	69												20	U		U												
5/16/2011	18	10	150																											
5/18/2011	20	10	180	200		0.15		4.5		4.65		2	U	7		5070	1	U	39	1	U	0.5	U		170	230	200			
5/20/2011	22	10	170	180																										
5/23/2011	25	8	170																											
5/25/2011	27	8	180	180		0.16		2.8		2.96		2	U	8		5070	1.4		45	1	U	0.5	U		180	260	200			
5/27/2011	29	8	160	160																										
6/1/2011	34	10	170	160																										
6/3/2011	36	10	190	180		0.13		1.8		1.93		2	U	2	U	>7380	1	U	41	1	U	0.5	U	0.1		170	250	200		
6/6/2011	39	12																												
6/10/2011	43	12	200																											
6/13/2011	46	12	150																											
6/16/2011	49	12	180			0.22		2.4		2.62																				
6/20/2011	53	12	140	130	0.5	U	0.08		0.31		0.39		4		4		>7380	0.66		49	1	U	0.5	U	0.1	U	180	250	200	
6/27/2011	60	12	11			0.11	U	0.15	U	0.26	U																			
7/5/2011	68	16	110	110	0.5	U	0.16		0.96		1.12		2	U	2	U	>7380	0.41		45	1	U	0.5	U	0.023		180	250	200	
7/11/2011	74	16	61	62		0.079		0.32		0.399		23		23		>7380	0.29		59	1	U	0.5	U	0.1	U		250	190		
7/18/2011	81	10																												
7/25/2011	88	20	11			0.078		0.15	U	0.228																180	250			
8/1/2011	95	22	14	15	0.11		0.11		0.15	U	0.26		2	U	2	U		30,000	0.26		41	1	U	0.5	U	0.18		190	240	190
8/8/2011	102	20	19																							0.12		0.09		
8/15/2011	109	18	12	13	0.5	U	0.16		0.16		0.32		2	U	2	U		17,000	0.39		52	1	U	0.5	U	0.027		180	250	200
8/17/2011	111	18	16																											

Date	Time	Target Flow Rate	Lag Reactor																											
			Perchlorate EPA Method 314.0	Perchlorate EPA Method 332.0	Ammonia	Nitrate	Nitrite	Nitrate+Nitrite	Fecal Coliforms	Total Coliforms	E. coli	Plate Count	DOC	TCE	cis 1,2-DCE	VC	Sulfide	Alkalinity	TDS	Turbidity	Hardness									
			µg/L	µg/L	mg/L-N	mg/L-N	mg/L-N	mg/L-N	MPN/100 ml	MPN/100 ml	MPN/100 mL	CFU/ml	mg/L	µg/L	µg/L	µg/L	µg/L	mg/L	mg/L	NTU	mg/L									
8/19/2011	113	18	26																											
8/26/2011	120	15	6.6	6.6	0.5	U	0.15	0.15	U	0.3	2	U	11		129,000	1.4	56	1	U	0.5	U	0.22	190	220		200				
8/31/2011	125	15	8.2																											
9/2/2011	127	15	8.8																											
9/7/2011	132	15	27	28	0.29		0.5	0.3		0.8	2	U	2		4,000	2.3	50	1	U	0.5	U	0.41	170	260		200				
9/9/2011	134	10	7.9																											
9/12/2011	137	10	9	8.6	0.14		0.16	0.11		0.27	4		2	U	1,600	1.4	52	1	U	0.5	U	4.0	170	250		190				
9/14/2011	139	10	13																											
9/16/2011	141	20	27																											
9/19/2011	144	5																												
10/3/2011	158	10	10				0.099	0.21		0.309																				
10/5/2011	160	10	8.1	9	0.13		0.11	U	0.15	U	0.11	2	U	27	46700	1.5	44	1	U	0.5	U	0.36	200	240		190				
10/7/2011	162	10	4.1																											
10/10/2011	165	5	20	U			0.11	U	0.15	U	0.11																			
10/12/2011	167	5	4	U																										
10/14/2011	169	5	4	U																										
10/17/2011	172	10	20		19	0.18	0.19	0.35		0.54	2	U	66.5		1200	0.44	49	1	U	0.5	U	0.074	190	240		180				
10/19/2011	174	10	12																											
10/21/2011	176	10	20																											
10/26/2011	181	10	16		17	0.17	0.12	0.2		0.32	2	U	17		8750	1	43	1	U	0.5	U	1.6	220	250		210				
10/28/2011	183	10	24																											
10/31/2011	186	10	16																											
11/2/2011	188	10	8.1	9.2	0.11		0.098	0.11	U	0.098	2	U	2		10600	2.2	45	1	U	1	U	3.3	190	240		180				
11/4/2011	190	10	9.3																											
11/7/2011	193	10	7.9																											
11/9/2011	195	10	8	6.7	0.5	U	0.097	0.15	U	0.097	2	U	34.4	U	2	U	145000	2	51	1	U	0.5	U	1.3	180	260		190		
11/11/2011	197	10	9.4																											
11/16/2011	202	10	9.5																											
11/18/2011	204	10	9.5	8.6	0.12		0.097	0.15	U	0.097	2	U	8		2	U	3400	1.2	39	1	U	0.5	U	0.31	190	240		210		
11/22/2011	208	10	16	14	0.5	U	0.11	U	0.29		0.4	2	U	50		2	U	25600	1.7	45	1	U	0.5	U	0.16	180	250		200	
11/28/2011	214	8	15	11	0.5	U	0.086	J	0.15	U	0.086	J	2	U	8		2	U	4250	2.4	41	1	U	0.5	U	0.15	190	210		200
11/30/2011	216	8	7.9																											

Date	Time	Target Flow Rate	MBfR Solids				Aeration																	
			Lead First Drain TSS	Lead Second Drain TSS	Lag First Drain TSS	Lag Second Drain TSS	TSS	TDS	Total Sulfide	Sulfate	Fecal Coliforms	Total Coliforms	Plate Count	E. coli	DOC	TCE	cis 1,2-DCE	VC	Turbidity					
			mg/L	mg/L	mg/L	mg/L	mg/L	mg/L	mg/L	mg/L	mg/L	MPN/100 ml	MPN/100 ml	CFU/ml	MPN/100 ml	mg/L	µg/L	µg/L	µg/L	NTU				
4/22/2011	-6	0																						
4/25/2011	-3	0																						
4/27/2011	-1	0																						
4/29/2011	1	5																						
5/2/2011	4	5																						
5/4/2011	6	5																						
5/6/2011	8	5					10	U				2	U	300	738		1	U	13	1	U	0.5	U	
5/9/2011	11	5																						
5/11/2011	13	5					10	U				2	U	240			1	U	19	1	U	0.5	U	
5/13/2011	15	8												< 20										
5/16/2011	18	10																						
5/18/2011	20	10					10	U				2	U	13	6,230		1	U	23	1	U	0.5	U	
5/20/2011	22	10																						
5/23/2011	25	8																						
5/25/2011	27	8					10	U				2	U	13	>7380		1.3		23	1	U	0.5	U	
5/27/2011	29	8																						
6/1/2011	34	10																						
6/3/2011	36	10					10	U				2	U	2	U	>7380		1	U	24	1	U	0.5	U
6/6/2011	39	12																						
6/10/2011	43	12																						
6/13/2011	46	12																						
6/16/2011	49	12																						
6/20/2011	53	12					10	U				4		4	>7380		0.37		28	1	U	0.5	U	
6/27/2011	60	12																						
7/5/2011	68	16					1					2	U	2	U	5,550		0.44		31	1	U	0.5	U
7/11/2011	74	16					10	U				11		23	>7380		0.29		41	1	U	0.5	U	
7/18/2011	81	10	<10	1	1	<10																		
7/25/2011	88	20																						
8/1/2011	95	22					10	U				2	U	2	U	6,000		1	U	31	1	U	0.5	U
8/8/2011	102	20	3.5	4.6	12	6.8					0.068													
8/15/2011	109	18					0.6					2	U	2		9,500		0.34		39	1	U	0.5	U
8/17/2011	111	18																						

Date	Time	Target Flow Rate	MBfR Solids				Aeration																
			Lead First Drain TSS	Lead Second Drain TSS	Lag First Drain TSS	Lag Second Drain TSS	TSS	TDS	Total Sulfide	Sulfate	Fecal Coliforms	Total Coliforms	Plate Count	E. coli	DOC	TCE	cis 1,2-DCE	VC	Turbidity				
			mg/L	mg/L	mg/L	mg/L	mg/L	mg/L	mg/L	mg/L	MPN/100 ml	MPN/100 ml	CFU/ml	MPN/100 ml	mg/L	µg/L	µg/L	µg/L	NTU				
8/19/2011	113	18							0.025	22													
8/26/2011	120	15					1.7		0.25	15	2	U	50	106,000			1.3	35	1	U	0.5	U	
8/31/2011	125	15																					
9/2/2011	127	15	3	4.4	5.6	3.8	0.5																
9/7/2011	132	15							0.2		2	U	4	3,000			2.2	29	1	U	0.5	U	
9/9/2011	134	10	3.5	4.5	5.7	5.0	0.9																
9/12/2011	137	10									13		7	200			2.2	29	1	U	0.5	U	
9/14/2011	139	10							0.46														
9/16/2011	141	20																					
9/19/2011	144	5							0.1	U	18												
10/3/2011	158	10																					
10/5/2011	160	10					0.5		0.22	11	2	U	13	32000			1.5	20	1	U	0.5	U	
10/7/2011	162	10																				2.3	
10/10/2011	165	5																					
10/12/2011	167	5	7.2	8	32	15																	
10/14/2011	169	5																					
10/17/2011	172	10					1	U	0.065	18	2	U	27	U	900		0.46	25	1	U	0.5	U	
10/19/2011	174	10																					
10/21/2011	176	10	4.2	3.8	17	4.8																	
10/26/2011	181	10					1	U	0.92	13	2	U	6	10500			1	31	1	U	0.5	U	
10/28/2011	183	10																					
10/31/2011	186	10																					
11/2/2011	188	10					0.3		0.29	11	2	U	4	9050			2.2	21	1	U	1	U	
11/4/2011	190	10	35	21	4.1	7.5																	
11/7/2011	193	10																					
11/9/2011	195	10					1	U	1.4	13	2	U	17	U	9550	2	U	2	26	1	U	0.5	U
11/11/2011	197	10	4.9	6.3	7.3	5.4																	
11/16/2011	202	10																					
11/18/2011	204	10					0.10		0.043	15	2	U	8	300	2	U	1.2	22	1	U	0.5	U	
11/22/2011	208	10					1	U	0.099	16	2	U	8	12600	2	U	1.7	22	1	U	0.5	U	
11/28/2011	214	8					1	U	0.056		2	U	2	U	200	2	U	2.6	17	1	U	0.5	U
11/30/2011	216	8																					

Date	Time	Target Flow Rate	Media Filter Effluent							Filter Backwash		
			TSS		Turbidity		Fecal Coliforms	Total Coliforms	Plate Count	E. coli	DOC	TSS
			mg/L	NTU	MPN/100 ml	MPN/100 ml	CFU/ml	MPN/100 mL	mg/L	mg/L		
4/22/2011	-6	0										
4/25/2011	-3	0										
4/27/2011	-1	0										
4/29/2011	1	5										
5/2/2011	4	5										
5/4/2011	6	5										
5/6/2011	8	5	1	U	2	U	50	623		1	U	
5/9/2011	11	5										
5/11/2011	13	5	1	U	2	U	30			1	U	
5/13/2011	15	8						< 20				
5/16/2011	18	10										
5/18/2011	20	10	1	U	2	U	2	1080				
5/20/2011	22	10								1	U	
5/23/2011	25	8										
5/25/2011	27	8	10	U	2	U	4	770				
5/27/2011	29	8										
6/1/2011	34	10										
6/3/2011	36	10	10	U	2	U	2	U	5550	1	U	
6/6/2011	39	12										
6/10/2011	43	12										
6/13/2011	46	12										
6/16/2011	49	12										
6/20/2011	53	12	1	U	2	U	2	U	3390	0.37		
6/27/2011	60	12										
7/5/2011	68	16	10	U	2	U	2	U	380	0.29		
7/11/2011	74	16			--		--		--	--		
7/18/2011	81	10										
7/25/2011	88	20										
8/1/2011	95	22	10	U	2	U	2	U	2,000	0.32		
8/8/2011	102	20										
8/15/2011	109	18			3		2	U	8,500	0.36		
8/17/2011	111	18										

Date	Time	Target Flow Rate	Media Filter Effluent									Filter Backwash		
			TSS		Turbidity		Fecal Coliforms		Total Coliforms		Plate Count	E. coli	DOC	TSS
			mg/L	U	NTU	J	MPN/100 ml	U	MPN/100 ml	CFU/ml	MPN/100 mL	mg/L	mg/L	
8/19/2011	113	18											200	
8/26/2011	120	15	1	U			2	U	23	106,000		0.91		
8/31/2011	125	15												
9/2/2011	127	15	1	U										
9/7/2011	132	15					2	U	2	U	60		1.4	
9/9/2011	134	10	0.5											
9/12/2011	137	10					2		2		11,100		1.3	
9/14/2011	139	10	1	U										
9/16/2011	141	20	55											
9/19/2011	144	5												
10/3/2011	158	10												
10/5/2011	160	10					2	U	2	U	1000		1	
10/7/2011	162	10			0.08	J							33	
10/10/2011	165	5												
10/12/2011	167	5											< 1.0	
10/14/2011	169	5												
10/17/2011	172	10	1	U			2	U	2	U	1150		0.7	
10/19/2011	174	10												
10/21/2011	176	10												
10/26/2011	181	10	1	U			2	U	2	U	6950		0.29	
10/28/2011	183	10												
10/31/2011	186	10												
11/2/2011	188	10	0.2				2	U	2		6700		1.3	
11/4/2011	190	10												
11/7/2011	193	10												
11/9/2011	195	10	1	U			2	U	7		16500	2	U	
11/11/2011	197	10												
11/16/2011	202	10												
11/18/2011	204	10	0.2				2	U	2		1150	2	U	
11/22/2011	208	10	1	U			2	U	2		5400	2	U	
11/28/2011	214	8	1	U			2	U	23		3200	2	U	
11/30/2011	216	8												

Date	Time	Target Flow Rate	Media Filter Effluent									Filter Backwash	
			TSS	Turbidity	Fecal Coliforms	Total Coliforms	Plate Count	E. coli	DOC	TSS			
			mg/L	NTU	MPN/100 ml	MPN/100 ml	CFU/ml	MPN/100 mL	mg/L	mg/L			
12/9/2011	225	6											
12/14/2011	230	6											
12/16/2011	232	6	26		2	U	11		4950	2	U	2.6	
12/19/2011	235	6	2		2	U	2	U	3550	2	U	2.2	
12/21/2011	237	6											
12/23/2011	239	6											
12/27/2011	243	6	0.6		2	U	2		6250	2	U	1.3	
12/28/2011	244	6											
12/30/2011	246	6											
1/3/2012	250	6	0.7	J	2	U	2	U	2200	2	U	1.3	
1/4/2012	251	6											66
1/6/2012	253	6											
1/9/2012	256	6	0.1	J	2	U	2	U	1200	2	U	0.34	
1/11/2012	258	6											
1/12/2012	259	6											99
1/13/2012	260	6											
1/17/2012	264	6											
1/18/2012	265	6											
1/20/2012	267	6											
1/23/2012	270	6											
1/25/2012	272	6											

Date	Time	Target Flow Rate	Finished Water (Product)																						
			Perchlorate EPA Method 314.0	Perchlorate EPA Method 332.0	Nitrate	Nitrite	Nitrate+Nitrite	Turbidity	Fecal Coliforms	Total Coliforms	Plate Count	E. coli	DOC	Total Sulfide	Odor	TTHM	TTHM - Formation Potential	HAA5	HAA6	N-Nitroso-diethyl-amine	N-Nitroso-dimethyl-amine	N-Nitroso-di-n-propylamine			
			µg/L	µg/L	mg/L	mg/L	mg/L	NTU	MPN/100 ml	MPN/100 ml	CFU/ml	MPN/100 ml	mg/L	mg/L		µg/L	µg/L	µg/L	µg/L	µg/L	µg/L	µg/L			
4/22/2011	-6	0																							
4/25/2011	-3	0																							
4/27/2011	-1	0																							
4/29/2011	1	5																							
5/2/2011	4	5																							
5/4/2011	6	5																							
5/6/2011	8	5								2	U														
5/9/2011	11	5																							
5/11/2011	13	5								623															
5/13/2011	15	8																							
5/16/2011	18	10																							
5/18/2011	20	10								2	U	2	U	800											
5/20/2011	22	10												2.3											
5/23/2011	25	8																							
5/25/2011	27	8								2	U	2	U	80											
5/27/2011	29	8																							
6/1/2011	34	10																							
6/3/2011	36	10								2	U	2	U	210											
6/6/2011	39	12																							
6/10/2011	43	12																							
6/13/2011	46	12																							
6/16/2011	49	12																							
6/20/2011	53	12								2	U	2	U	380											
6/27/2011	60	12												0.42											
7/5/2011	68	16								2	U	2	U	120											
7/11/2011	74	16								--	--			--											
7/18/2011	81	10																							
7/25/2011	88	20																							
8/1/2011	95	22								2	U	2	U	<1000											
8/8/2011	102	20												0.025											
8/15/2011	109	18								2	U	2	U	279											
8/17/2011	111	18	16																						

Date	Time	Target Flow Rate	Finished Water (Product)																													
			Perchlorate EPA Method 314.0	Perchlorate EPA Method 332.0	Nitrate	Nitrite	Nitrate+Nitrite	Turbidity	Fecal Coliforms	Total Coliforms	Plate Count	E. coli	DOC	Total Sulfide	Odor	TTHM	TTHM - Formation Potential	HAA5	HAA6	N-Nitroso-diethyl-amine	N-Nitroso-dimethyl-amine	N-Nitroso-di-n-propylamine										
			µg/L	µg/L	mg/L	mg/L	mg/L	NTU	MPN/100 ml	MPN/100 ml	CFU/ml	MPN/100 ml	mg/L	mg/L		µg/L	µg/L	µg/L	µg/L	µg/L	µg/L	µg/L										
8/19/2011	113	18	27	24										2.0	1.1		6	U	7	U												
8/26/2011	120	15	6.9	6.3					2	U	2	U	24		1.1	0.02		6	U	7	U											
8/31/2011	125	15	8.7																													
9/2/2011	127	15	11																													
9/7/2011	132	15	30	29.5					2	U	2		520		1.3	0.1	U		4	U		6	U	7	U							
9/9/2011	134	10	8.1											7																		
9/12/2011	137	10	9.3	8.0					2	U	2	U	94		1.3	0.033			<0.0005			6	U	7	U							
9/14/2011	139	10	4	U																												
9/16/2011	141	20	28																													
9/19/2011	144	5																														
10/3/2011	158	10	12		0.31	<0.15		0.46																								
10/5/2011	160	10	8.1	8					2	U	2	U	719																			
10/7/2011	162	10	6.3						0.1	J																						
10/10/2011	165	5	5.3																													
10/12/2011	167	5	3.4	J																												
10/14/2011	169	5	4.6																													
10/17/2011	172	10	22	23					2	U	2	U	141		0.68	0.1	U		1.3			3.1		3.8								
10/19/2011	174	10	15																													
10/21/2011	176	10	20																													
10/26/2011	181	10	16	18					2	U	2	U	58		0.32	0.1	U	1	U			1.6		1.6								
10/28/2011	183	10	26																													
10/31/2011	186	10	17																													
11/2/2011	188	10	12	11					2	U	2	U	1	U	1.2	0.04			4	U		1.4		1.4								
11/4/2011	190	10	13																													
11/7/2011	193	10	10																													
11/9/2011	195	10	8.9	7.1					2	U	2	U	22	2	U	1.2	0.024			4	U		1.3		1.6							
11/11/2011	197	10	7.6																													
11/16/2011	202	10																														
11/18/2011	204	10	10	8.5					2	U	2	U	10	2	U	0.35	0.065			4	U		1		1							
11/22/2011	208	10	20	17					2	U	2	U	136	2	U	1.1	0.1	U		4	U		6	U	7	U						
11/28/2011	214	8	14		0.22	0.15	U	0.22	2	U	2	U	1	U	2	U	1.9	0.1	U	1	U		8.8		9.3	0.0019	U	0.0019	U	0.00079	J	
11/30/2011	216	8	8.1																													

Date	Time	Target Flow Rate	Finished Water (Product)																																
			Perchlorate EPA Method 314.0	Perchlorate EPA Method 332.0	Nitrate	Nitrite	Nitrate+Nitrite	Turbidity	Fecal Coliforms	Total Coliforms	Plate Count	E. coli	DOC	Total Sulfide	Odor	TTHM	TTHM - Formation Potential	HAA5	HAA6	N-Nitroso-diethyl-amine	N-Nitroso-dimethyl-amine	N-Nitroso-di-n-propylamine													
			µg/L	µg/L	mg/L	mg/L	mg/L	NTU	MPN/100 ml	MPN/100 ml	CFU/ml	MPN/100 ml	mg/L	mg/L		µg/L	µg/L	µg/L	µg/L	µg/L	µg/L	µg/L	µg/L												
12/9/2011	225	6																																	
12/14/2011	230	6	11																																
12/16/2011	232	6	8.3		0.2	0.15	U	0.2		2	U	2	U	36	2	U	2.3	0.021	J	1	U	4	U	13	6	U	7	U	0.00075	J	0.0019	U	0.0019	U	
12/19/2011	235	6	10		0.24	0.15	U	0.24		2	U	2	U	22	2	U		0.028	J	1	U	1.1			3		3		0.0019	U	0.0019	U	0.0019	U	
12/21/2011	237	6	11																																
12/23/2011	239	6	11																																
12/27/2011	243	6	7.8		0.44	0.15	U	0.44		2	U	2	U	16	2	U	1.6	0.026		1	HFT	4	U	11	6	U	7	U	0.00068	J	0.0019	U	0.0019	U	
12/28/2011	244	6	12																																
12/30/2011	246	6	12																																
1/3/2012	250	6	9.8		0.23	0.15	U	23		2	U	2		1	U	2	U	1.3	0.041		5		4	U	14	1.9		1.9		0.0019	U	0.0019	U	0.0019	U
1/4/2012	251	6	17																																
1/6/2012	253	6	9.3																																
1/9/2012	256	6	7.7		0.21	0.15	U	0.21		2	U	2	U	140	2	U	0.43	0.029		1		4	U	8.7	B	1	U	1	U	0.0019	U	0.0019	U	0.0019	U, L
1/11/2012	258	6	16																																
1/12/2012	259	6																																	
1/13/2012	260	6	13		0.23	H	0.15	U, H	0.23																										
1/17/2012	264	6	17		0.45		0.15	U	0.45																										
1/18/2012	265	6	13		0.23		0.15	U	0.23																										
1/20/2012	267	6	17		0.44		0.15	U	0.44																										
1/23/2012	270	6	9.9		0.3		0.15	U	0.3																										
1/25/2012	272	6	11		0.26		0.15	U	0.26																										

Date	Time	Target Flow Rate	GAC-1				IX - 1		Outfall																			
			TCE		cis 1,2-DCE		VC		Acetone		Perchlorate EPA Method 314.0	Perchlorate EPA Method 332.0	TCE		cis 1,2-DCE		VC	Acetone		Sulfate	TDS	Ethylene Diomide	Chloride	Phosphate	Ammonia	Hardness		
			µg/L	µg/L	µg/L	µg/L	µg/L	µg/L	µg/L	µg/L	µg/L	µg/L	µg/L	µg/L	µg/L	µg/L	µg/L	µg/L	µg/L	mg/L	mg/L	µg/L	mg/L	mg/L	mg/L-N	mg/L		
4/22/2011	-6	0																										
4/25/2011	-3	0																										
4/27/2011	-1	0																										
4/29/2011	1	5	1	U	1	U			10	U	4	U	4	U	1	U	1	U	< 0.5	10	U	0.35	220	< 0.01	100	< 0.16	< 0.5	160
5/2/2011	4	5																										
5/4/2011	6	5																										
5/6/2011	8	5	1	U	1	U			10	U	4	U	4	U	1	U	1	U		10	U							
5/9/2011	11	5																										
5/11/2011	13	5	1	U	1	U			10	U	4	U	4	U	22		1	U		10	U							
5/13/2011	15	8																										
5/16/2011	18	10																										
5/18/2011	20	10	1	U	1	U	0.5	U	5.4		4	U	4	U	1	U	1	U	< 0.5	10	U							
5/20/2011	22	10																										
5/23/2011	25	8																										
5/25/2011	27	8	1	U	1	U	--		10	U	4	U	4	U	1	U	1	U	--	10	U							
5/27/2011	29	8																										
6/1/2011	34	10																										
6/3/2011	36	10	1	U	1	U	--		10	U	4	U	4	U	1	U	1	U	--	10	U							
6/6/2011	39	12																										
6/10/2011	43	12									4	U	4	U														
6/13/2011	46	12																										
6/16/2011	49	12																										
6/20/2011	53	12	1	U	1	U	--		10	U	4	U	4	U	1	U	1	U	--	10	U							
6/27/2011	60	12									4	U	4	U														
7/5/2011	68	16	1	U	1	U	--		10	U	4	U	4	U	1	U	1	U	--	10	U							
7/11/2011	74	16	1	U	1	U	0.5	U	10	U	4	U	4	U	1	U	1	U	--	10	U							
7/18/2011	81	10	1	U	1	U	0.5	U	10	U			4	U	1	U	1	U	--	10	U							
7/25/2011	88	20									4	U	4	U														
8/1/2011	95	22	1	U	1	U	0.5	U	10	U	4	U	4	U	1	U	1	U	--	10	U							
8/8/2011	102	20									4	U	4	U														
8/15/2011	109	18	1	U	1	U	--		10	U	4	U	4	U	1	U	1	U	--	10	U							
8/17/2011	111	18																										

Date	Time	Target Flow Rate	GAC-1							IX - 1		Outfall																		
			TCE		cis 1,2-DCE		VC		Acetone		Perchlorate EPA Method 314.0		Perchlorate EPA Method 332.0		TCE		cis 1,2-DCE		VC		Acetone		Sulfate	TDS	Ethylene Diromide	Chloride	Phosphate	Ammonia	Hardness	
			µg/L	U	µg/L	U	µg/L	U	µg/L	U	µg/L	U	µg/L	U	µg/L	U	µg/L	U	µg/L	U	µg/L	U	µg/L	U	mg/L	mg/L	µg/L	mg/L	mg/L	mg/L-N
12/9/2011	225	6	1	U	1	U	--		10	U	4	U	4	U	1	U	1	U	--	10	U									
12/14/2011	230	6																												
12/16/2011	232	6	1	U	1	U	--		10	U	4	U	4	U	1	U	1	U	--	10	U									
12/19/2011	235	6	1	U	1	U	--		10	U	4	U	4	U	1	U	1	U	--	10	U									
12/21/2011	237	6																												
12/23/2011	239	6																												
12/27/2011	243	6	1	U	1	U	--		10	U	4	U	4	U	1	U	1	U	--	10	U									
12/28/2011	244	6																												
12/30/2011	246	6																												
1/3/2012	250	6	1	U	1	U	--		10	U	4	U	4	U	1	U	1	U	--	10	U									
1/4/2012	251	6																												
1/6/2012	253	6																												
1/9/2012	256	6	1	U	1	U	--		10		4	U	4	U	1	U	1	U	--	10	U									
1/11/2012	258	6																												
1/12/2012	259	6																												
1/13/2012	260	6																												
1/17/2012	264	6	1	U	1	U	--		10					1	U	1	U	--	10	U										
1/18/2012	265	6										4	U																	
1/20/2012	267	6																												
1/23/2012	270	6																												
1/25/2012	272	6																												

Notes: MBfR 1 & MBfR 2 rotated sample points every 3 days due to lead/lag configuration (field verification completed during sampling for laboratory). Non detects are listed as the reporting limit.

Qualifiers:

- B Analyte was detected in the associated Method Blank.
- H Sample analysis performed past method-specified holding time.
- HFT The holding time is immediate. It was analyzed in the laboratory as soon as possible after receipt.
- J RL < Result ≤ MDL. The concentration is an approximate value.
- L Laboratory Control Sample and/or Laboratory Control Sample Duplicate recovery was above the acceptance limits. Analyte not detected, data not
- U Analyte NOT DETECTED at or above the RL or MDL, if MDL is specified.

Acronyms:

- | | | | |
|-------------|--|------|------------------------|
| CFU/ml | colony forming units per milliliter | RL | reporting limit |
| cis 1,2-DCE | cis-1,2-Dichloroethene | TCE | trichloroethene |
| DOC | dissolved organic carbon | TDS | total dissolved solids |
| E. coli | Escherichia coli | TTHM | total trihalomethanes |
| EPA | USA Environmental Protection Agency | TSS | total suspended solids |
| gpm | gallons per minute | VC | vinyl chloride |
| mg/L | milligram per liter | µg/L | micrograms per liter |
| mg/L-N | milligram as nitrogen per liter | > | greater than |
| MPN/100 ml | most probable number per 100 milliliters | < | less than |
| MDL | maximum daily load | ≤ | less than or equal to |
| NTU | nephelometric turbidity units | | |

APPENDIX G
ONLINE MONITORING DATA
(EXCEL FILE ATTACHED)

APPENDIX H

EAST VALLEY WATER DISTRICT DEMONSTRATION SUMMARY

1.0 INTRODUCTION

A membrane biofilm reactor (MBfR) and media filtration system were demonstrated at East Valley Water District (EVWD) for perchlorate and nitrate destruction and potable water production. The MBfR contained hydrogen-pressurized hollow fibers, which supported the growth of perchlorate-reducing bacteria (PRB) on the fibers. MBfR modules were composed of Cellulose Triacetate (CTA) membranes and plug-flow conditions to minimize reactor volume and sustain higher volumetric loadings. The MBfR included a three-stage process (Figure 1). In addition, aerobic biodegradation, media filtration and chlorination are integrated as downstream processes for the removal of dissolved organic carbon (DOC), suspended solids, and bacteria and disinfection. This demonstration was initiated in late 2007 and lasted about 6 months. The demonstration was conducted at EVWD Well 28A located in San Bernardino, California.

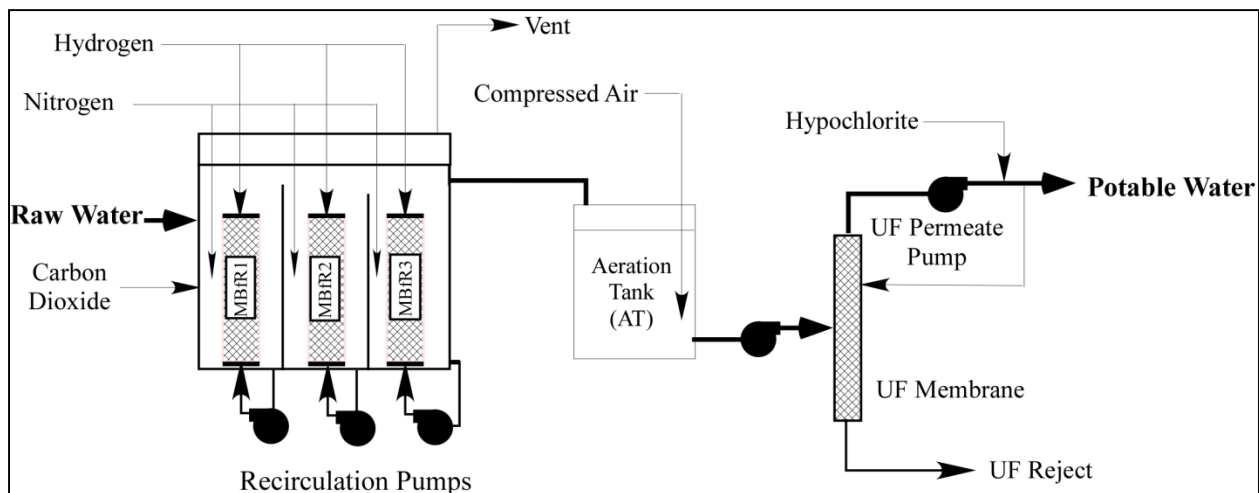

Figure 1 Process Flow Diagram

1.2 PERFORMANCE OBJECTIVES

The goal of this study was to demonstrate and validate the performance of the MBfR system as a suitable method to destroy perchlorate and nitrate in groundwater and produce potable water. The MBfR system was also evaluated for compliance with associated regulatory requirements with respect to potable water production standards.

Quantitative and qualitative performance objectives were established to assess success of the technology's application. Safety and permit compliance qualitative performance objectives specifically addressed demonstration activities rather than the technology, but were critical for a successful demonstration. Taste and odor were also considered as a critical aspect of general public acceptance, but are not regulated. Quantitative performance objectives for perchlorate and nitrate reduction were selected to be more stringent than regulatory requirements because

influent concentrations are relatively low when compared to typical ranges in groundwater (Table 2). Groundwater was spiked with 50 micrograms per liter ($\mu\text{g/L}$) of perchlorate. The quantitative performance objective for perchlorate removal was based on the California maximum contaminant level (MCL) of 6 $\mu\text{g/L}$. Nitrite had the potential to accumulate as an intermediate of nitrate reduction. Therefore, it was assigned a performance objective equal to 50% of its MCL. Disinfection and filtration are regulatory requirements. Additional criteria are reported and summarized in Table 1 to address disinfection requirements and biological stabilization of the effluent.

Table 1 Performance Objectives and Related Success Criteria

Performance Objective		Success Criteria
Qualitative	Safety	No reportable health and safety incidents
	Permit compliance	No violations
	Taste and odor	Treatment by the MBfR process results in production of an aesthetically acceptable product
	Regulatory acceptance	Obtain letter of conditional acceptance from the California Department of Public Health (CDPH)
Quantitative	Contaminant destruction	< 6 $\mu\text{g/L}$ perchlorate
	Disinfection	Coliforms ND, HPC < 500/mL
	Filtration	(Turbidity < 0.2 NTU)
	Biological stabilization	DOC < 2 mg/L

Table 2 Typical Groundwater Chemistry Parameter Ranges

Analyte	Range	Units
Perchlorate	<4 to 9.6	$\mu\text{g/L}$
Nitrate	7.0 to 8.6	mg-N/L
Sulfate	29 to 50	mg/L
Alkalinity	118 to 130	mg CaCO_3/L
Hardness	143 to 200	mg CaCO_3/L
Total dissolved solids	190 to 280	mg/L
pH	7.70 to 8.15	SU

2.0 RESULTS - DEMONSTRATION TESTING

The demonstration included 1) a start-up phase designed to promote PRB growth on the hollow fiber membranes, and 2) an optimization phase to investigate different operational conditions and their impact on contaminant removal, operation and maintenance requirements.

2.1 START-UP PHASE

A culture of PRB, grown at Arizona State University in Professor Rittmann's laboratory using Well 28A groundwater, was used as inoculum for the MBfR biomass formation. The influent flow was set at 1 gallon per minute (gpm) to allow sufficient residence time for the bacteria to

colonize the hollow fiber membranes. Typical raw water nitrate and perchlorate concentrations after spiking were approximately 7 milligrams per liter (mg/L) and 43 μ g/L, respectively.

The enriched biofilm formation led to a progressive increase of perchlorate removal in the following 7 weeks after bacterial inoculum. Perchlorate removal reached around 28% and 50% after 4 and 5 weeks of system operation, respectively. Six weeks were needed to achieve effluent perchlorate concentrations less than 6 μ g/L, which met the success criteria of the related performance objective. About 72% nitrate and nitrite removal was achieved after 4 weeks. Effluent nitrate and nitrite levels below detection limits were reached by the end of this initial two-month start-up period (Figure 2).

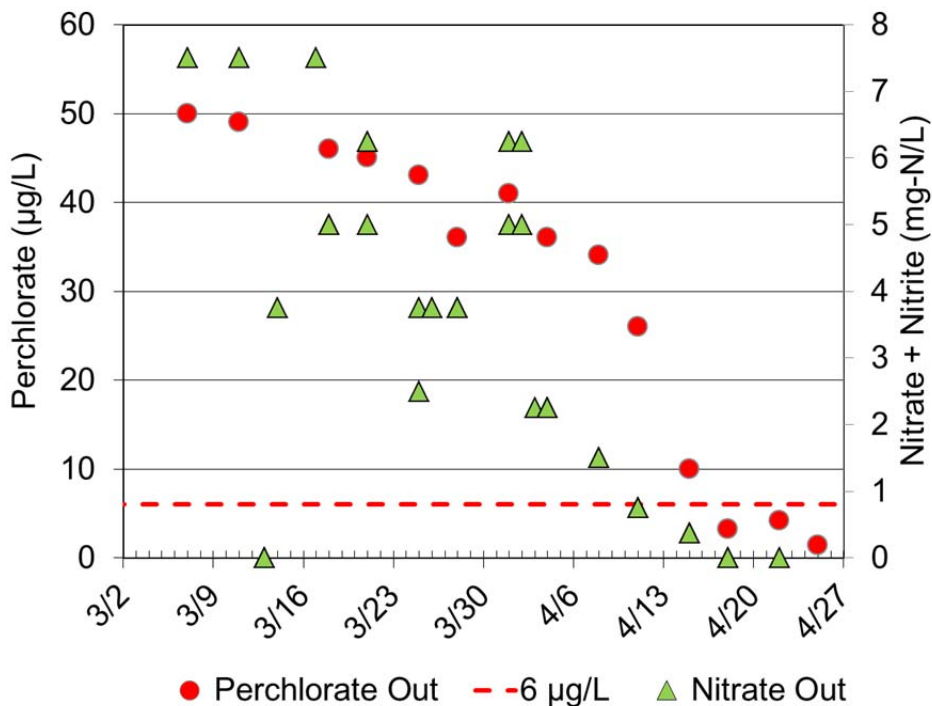

Figure 2 MBfR Start-up Perchlorate and Nitrate and Nitrite Effluent Concentrations

2.2 OPTIMIZATION PHASE

The primary goal of the optimization phase was to identify optimal operating conditions for the MBfR system and perchlorate removal. After the acclimation period, MBfR operational conditions were varied to test the system response to changes in influent and recirculated water flow rates, and influent perchlorate concentrations.

Influent Flow Rate

The MBfR was tested with progressive increase in influent flow rates to determine the stability of the system to variable loadings. Flow rates of 1, 3 and 6 gpm were maintained over time periods as shown in Figure 3. Influent concentrations of perchlorate (~ 55 μ g/L) and of nitrate

[approximately 7 milligrams as nitrogen per liter (mg-N/L)] were constantly fed to the reactor through the duration of the test.

The results show optimal perchlorate and nitrate removal performances at 1 gpm, with effluent concentrations of perchlorate below the success criteria of 6 $\mu\text{g/L}$ as shown in Figure 3. Perchlorate removal was maintained in the following week, with a flow rate of 3 gpm. However, this operational change increased effluent nitrate and nitrite concentrations to levels that did not meet performance requirements for nitrate and nitrite.

The reactor performance abruptly deteriorated during the following 3 weeks when the system was operated at 6 gpm. The performance metrics were again not met. In these conditions, effluent perchlorate concentrations around 45 $\mu\text{g/L}$ were reported, and steady nitrate and nitrite concentrations around 3.8 mg-N/L were reached.

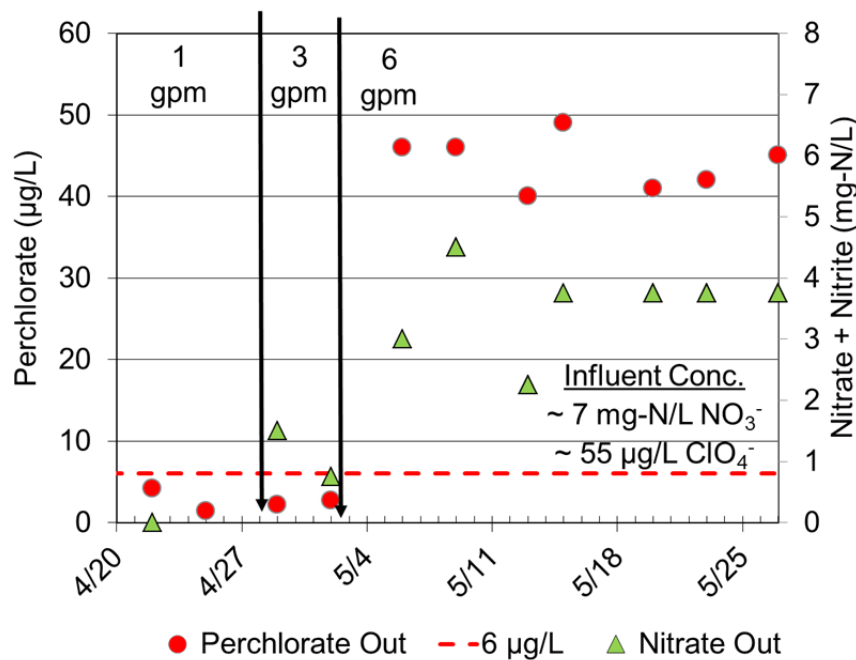

Figure 3 Effect of Increased MBfR Influent Flow Rate, Effluent Perchlorate and Effluent Nitrate and Nitrite

The MBfR system resilience was evaluated by returning to more optimal conditions at lower flows (3 and 1 gpm) as shown in Figure 4. Perchlorate and nitrate removal were improved at 3 gpm, although the success criteria were generally not met. Perchlorate removal performance did improve at 1 gpm, but did not recover. However, the progressive decrease in flow rate was beneficial to the removal of nitrate, which again reached undetectable levels after 2 weeks at the 1 gpm regime.

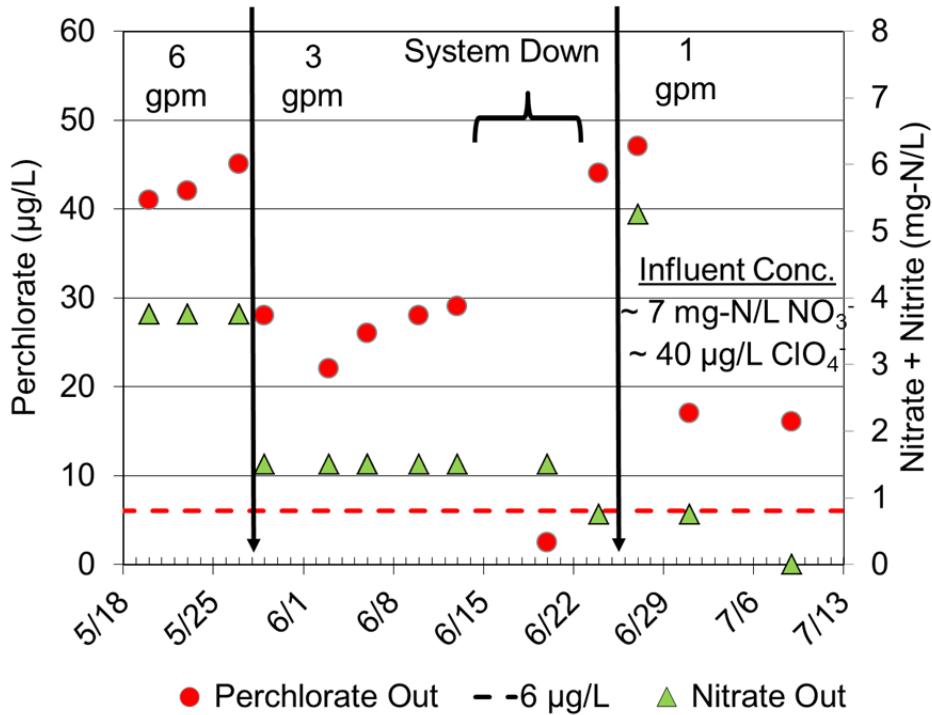

Figure 4 Effect of Decreased MBfR Influent Flow Rate on Effluent Perchlorate and Effluent Nitrate and Nitrite

These results demonstrate that the MBfR is not capable of consistently removing perchlorate and nitrate and nitrite below the set success criteria (50 µg/L to less than 6 µg/L perchlorate and less than 0.5 mg-N/L nitrate and nitrite) at flow rates greater than 1 gpm. Furthermore, after conditions of upset, the system was not able to fully recover its perchlorate removal capability.

Recirculation Increase

After the influent flow was returned to 1 gpm, recirculation of reject through the MBfR was used to support system recovery by promoting PRB colonization. The recycle rate was increased from 90 gpm to 180 gpm while maintaining 1 gpm influent flow. This increase improved perchlorate removal by about 65% and decreased effluent concentrations to approximately 19 µg/L (Figure 5). However, this did not meet the success criteria. On the other hand, changes in recirculation flow improved nitrate removal to undetectable levels.

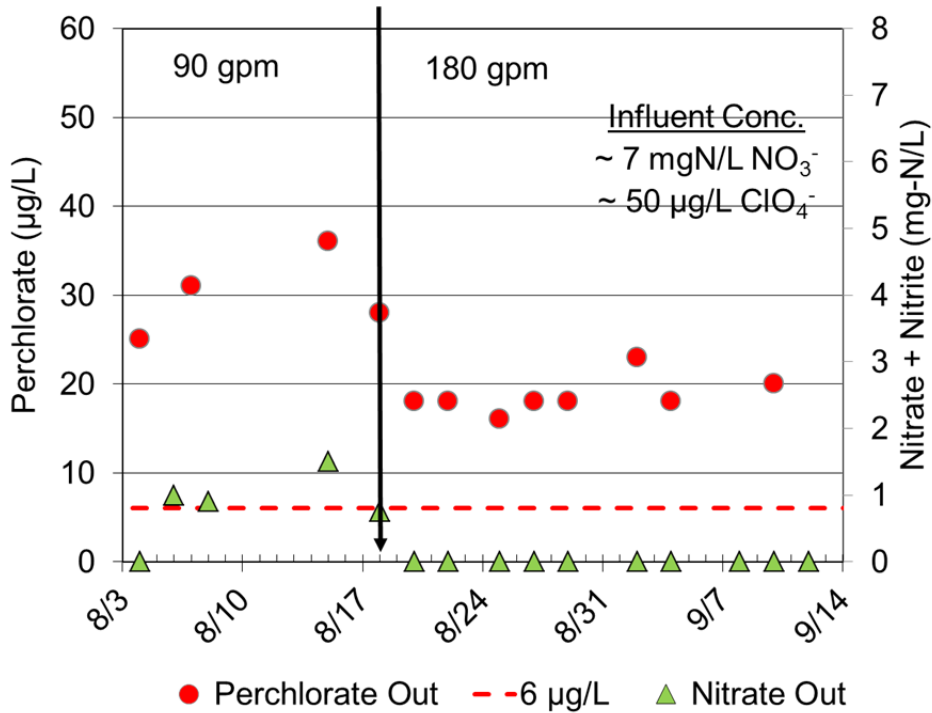

Figure 5 Effect of Increased MBfR Recirculation Flow on Perchlorate and Nitrate and Nitrite Removal

Influent Perchlorate Concentration Decrease

MBfR performance improved when the influent perchlorate concentration was lowered from 50 µg/L to 15 µg/L (Figure 6). These perchlorate dose concentrations were closer to those typically measured in the EVWD groundwater. Reducing the influent perchlorate concentration to 15 µg/L resulted in effluent concentrations lower than 6 µg/L, meeting the success criteria for perchlorate. In parallel, increased effluent concentrations of nitrate and nitrite were observed at levels that inconsistently met the success criteria for the corresponding performance objective.

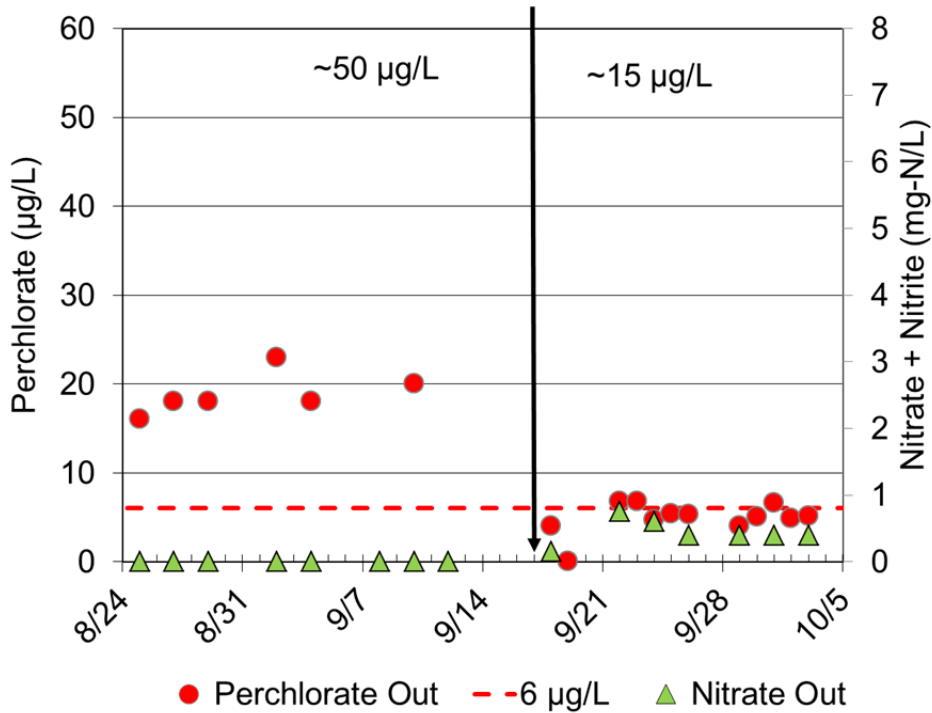

Figure 6 Effect of Decreased MBfR Influent Perchlorate Concentration on Perchlorate and Nitrate and Nitrite Removal

3.0 DISCUSSION AND CONCLUSIONS

During the initial start-up of the MBfR, successful perchlorate removal was achieved in about 6 weeks, with influent concentrations of 50 µg/L being reduced to less than 6 µg/L at a flow rate of 1 gpm. During the optimization phase, perchlorate and nitrate removal capability declined when altering operating conditions. Visual observation of uneven bacterial distribution at the membrane surfaces among the three bioreactors operating in series (Figure 7), the high accumulation of biomass in the first MBfR stage, and the limited biofilm density of the third MBfR stage indicated a poor biofilm control and possible poor flow distribution, thus the loss of effective membrane surface area for mass transfer to occur. Hence, the operational conditions tested might have developed mass transfer limitations, which were partially overcome by increasing water recirculation rates. Alternative membrane configurations and different operating strategies may be able to address the limitations encountered, and further systematic process improvements need to be evaluated. The design for the follow-on demonstration at West Valley Water District built on key findings from this project.

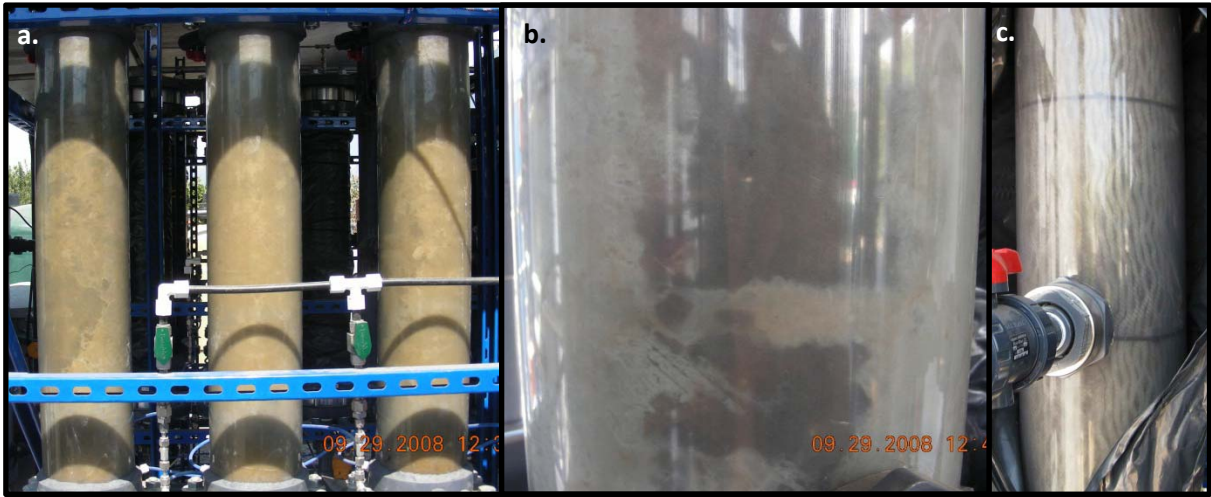

Figure 7 MBfR Modules from Stage 1 (a), Stage 2 (b), and Stage 3 (c).

APPENDIX I
CDPH LETTER OF CONDITIONAL ACCEPTANCE



RON CHAPMAN, MD, MPH
Director & State Health Officer

State of California—Health and Human Services Agency
California Department of Public Health



EDMUND G. BROWN JR.
Governor

July 26, 2013

Mr. John Bosler
Chief Operations Officer
Cucamonga Valley Water District
P.O. Box 638
Rancho Cucamonga, CA 91730

Mr. David Friese
ARoNite Technology Director
APTwater, Inc.
2516 Verne Roberts Circle, Suite H-102
Antioch, CA 94509

CONDITIONAL ACCEPTANCE OF ARONITE BIOLOGICAL TREATMENT FOR THE PRODUCTION OF DRINKING WATER FROM NITRATE CONTAMINATED WATER

Dear Mr. Bosler and Mr. Friese:

The Water Treatment Committee (WTC) of the Drinking Water Program in the California Department of Public Health (Department) has reviewed the following documents submitted with your request to gain acceptance of ARoNite (Autotrophic Reduction of Nitrate) biological treatment as a means of removing nitrate from source waters prior to distribution as part of the public water supply.

“Well 23 ARoNite 30 Day Demonstration Report, April 12, 2012” prepared by APTwater for Cucamonga Valley Water District

“Well 23 ARoNite Extended Demonstration Report, January 21, 2013” prepared by APTwater for Cucamonga Valley Water District

Based on the review of the above pilot study reports, the WTC hereby confirms that the ARoNite biological treatment process has been demonstrated to remove nitrate from some sources of water. The ARoNite process is a hydrogen based membrane biofilm biological treatment system for the removal of nitrate. The ARoNite system uses native microorganisms present in the groundwater and hydrogen gas as the electron donor for microbial respiration. The biological treatment process occurs in a proprietary sealed treatment vessel where membranes are used to deliver hydrogen gas to the biofilm.

Division of Drinking Water and Environmental Management, Drinking Water Technical Operations Section

850 Marina Bay Parkway, Building P, 2nd Floor, Richmond, CA 94804

Telephone: (510) 620-3474 Fax: (510) 620-3455

Internet Address: <http://www.cdph.ca.gov/programs/Pages/DWP.aspx>

The pilot study result indicates that a properly designed and operated ARoNite biological treatment system can be used as one of the unit processes for the removal of nitrate from some water sources. Thus it can be incorporated into an overall drinking water treatment plant. Nevertheless, we consider the ARoNite biological treatment system to be capable of nitrate removal with several important caveats that have been incorporated into the conditions presented below.

The WTC accepts the ARoNite biological treatment system to remove or reduce nitrate from some source water(s) that might be used for potable supply subject to the following conditions:

1. The system is operated in a manner that maximizes steady state conditions and minimizes intermittent production flow rates (e.g., a plant operated 24 hours a day, 7 days a week).
2. Continuous on-line monitoring systems for water flow, nitrate, turbidity, chlorine residual and dissolved oxygen shall be incorporated into the process design with adequate alarm strategies detailed in the water system's operation plan.
3. Site-specific tests are required to determine the impact of seasonal and temporal variations in water quality (nitrate concentration, temperature, available micro and macro nutrients, and/or hydraulic loading rates, etc.) on process performance. For example, it is anticipated that the hydrogen feed requirement will vary as a function of source water quality, so the impact(s) of variable nitrate concentrations (in time and magnitude) on finished water quality needs to be evaluated. The site-specific verification testing should represent worst-case conditions and the testing periods must cover the time during the seasonal and temporal variations in water quality.
4. Nitrate reduction process control shall be based on the constant influent flow with variable hydrogen pressure scheme that was demonstrated during the extended demonstration period.
5. Filtration treatment process control shall be based on the use of an optimum dose of coagulant that includes adequate flash mixing and an acceptable filter design.
6. Source of the microbiological seed must be identified and characterized as not containing human pathogens, except when indigenous biota are selected to inoculate the bed. The use of indigenous microorganisms to "seed" the reactor renders this condition moot.

7. All chemicals used in the system must be NSF/ANSI standard 60 certified by an ANSI accredited testing organization.
8. All materials that come into direct contact with the source water must be NSF/ANSI standard 61 certified by an ANSI accredited testing organization.
9. A pressure sensor with alarm should be installed on the hydrogen feed system.
10. Following biological treatment, the filtration, disinfection and other treatment processes will be required to meet the following performance standards:
 - a. 4-log virus inactivation must be achieved by the end of the disinfection treatment process.
 - b. Treated water must be coliform free. Weekly or monthly samples collected at the end of the disinfection treatment process will be required.
 - c. Treated water must contain HPC of less than 500 cfu/mL. Weekly or monthly samples collected at the end of the disinfection treatment process will be required.
 - d. Individual filtered water effluent turbidity shall be 0.3 NTU or less, 95% of the time. Continuous monitoring of filter effluent will be required.
 - e. Corrosivity of the effluent water must be monitored and controlled prior to distribution, if necessary. Daily treated water pH reading of the plant effluent will be required.
 - f. Distribution system disinfectant by-products samples must be collected based on the Stage 2 Disinfectant / Disinfection By-Products Rule and must comply with the Locational Running Annual Average (LRAA) for TTHM and HAA5 MCLs.
 - g. Treated water must meet all secondary standards.
 - h. Treated water needs to have sufficient dissolved oxygen to stabilize the water prior to distribution to consumers.
11. Proper operator certification of the facility will be required based on the complexity of the full scale treatment system.
12. An operator training program for the biological treatment system shall be provided as part of the start-up process for the full scale treatment system.

Mr. John Bosler and Mr. David Friese
July 26, 2013
Page 4

We note that membrane biofilm reactor biological treatment has not been proven to work on all water sources. Therefore, additional testing will be required to confirm the treatment system's performance prior to full scale installations at other use sites. To ensure the acceptability of the study approach, prior to starting, the local CDPH Drinking Water Program District Engineer should be consulted to ensure that the study is conducted in sufficient detail so that adequate information is gathered to identify the critical design and operating factors of the full scale treatment plant.

Be advised that the approval for the design and use of this technology in any drinking water application will be handled on a case-by-case basis by the Drinking Water Program's district offices. The individual district offices based on specific site requirements may specify additional unit treatment processes as well as require additional pilot testing or full-scale demonstration of the treatment process. Approval is granted through the domestic water supply permitting process. Information such as the study results, technical drawings, plans and specifications will need to be submitted with the application and will be used for the development of the water supply permit.

We would like to thank you and your colleagues for working with us during the development and testing of this technology. Should you have any questions regarding the content of this letter, please free to contact me at (510) 620-3460.

Sincerely,



Eugene H. Leung, P.E.
Senior Sanitary Engineer
Technical Operations Section

cc: Water Treatment Committee