

ESTCP Cost and Performance Report

(ER-200542)



Demonstration of New, Highly Perchlorate- Selective Ion Exchange Resin Coupled with Resin-Optimized, Single-Vessel Engineering Design

March 2013



ENVIRONMENTAL SECURITY
TECHNOLOGY CERTIFICATION PROGRAM

U.S. Department of Defense

COST & PERFORMANCE REPORT

Project: ER-200542

TABLE OF CONTENTS

	Page
EXECUTIVE SUMMARY	1
OBJECTIVES OF THE DEMONSTRATION.....	1
TECHNOLOGY DESCRIPTION	1
DEMONSTRATION RESULTS.....	2
IMPLEMENTATION ISSUES.....	3
1.0 INTRODUCTION	5
1.1 BACKGROUND	5
1.2 OBJECTIVES OF THE DEMONSTRATION.....	5
1.3 REGULATORY DRIVERS	5
2.0 TECHNOLOGY DESCRIPTION	7
2.1 TECHNOLOGY/METHODOLOGY OVERVIEW.....	7
2.2 TECHNOLOGY DEVELOPMENT.....	17
2.3 ADVANTAGES AND LIMITATIONS OF THE TECHNOLOGY.....	17
3.0 PERFORMANCE OBJECTIVES	21
4.0 FACILITIES/SITE DESCRIPTION.....	23
4.1 FACILITY/SITE LOCATION AND OPERATIONS.....	23
5.0 TEST DESIGN	27
5.1 PRE-DEMONSTRATION TESTING AND ANALYSIS	27
5.2 CONCEPTUAL DESIGN AND BASELINE CHARACTERIZATION.....	27
5.3 DESIGN AND LAYOUT OF TECHNOLOGY COMPONENTS	27
5.4 OPERATIONAL TESTING.....	27
5.4.1 DEMONSTRATION SET-UP AND START-UP.....	27
5.4.2 PERIOD OF OPERATION	29
5.4.3 TREATMENT RATE.....	30
5.4.4 RESIDUALS HANDLING	30
5.4.5 OPERATING PARAMETERS FOR THE TECHNOLOGY.....	30
5.4.6 EXPERIMENTAL DESIGN	30
5.4.7 PERFORMANCE MONITORING	32
5.5 SAMPLING PROTOCOL.....	33
5.6 SAMPLING RESULTS.....	33
6.0 PERFORMANCE ASSESSMENT	35
6.1 PERFORMANCE CRITERIA.....	35
6.2 PERFORMANCE CONFIRMATION METHODS.....	35
6.3 DATA ANALYSIS, INTERPRETATION AND EVALUATION.....	36
6.4 WVWD – PERFORMANCE DATA.....	37

TABLE OF CONTENTS (continued)

		Page
6.5	CITY OF COLTON – PERFORMANCE DATA	39
6.6	CITY OF RIALTO – PERFORMANCE DATA.....	40
7.0	COST ASSESSMENT	43
7.1	COST MODEL	43
7.2	COST ANALYSIS.....	43
8.0	IMPLEMENTATION ISSUES	45
8.1	ENVIRONMENTAL CHECKLIST	45
8.2	OTHER REGULATORY ISSUES.....	45
8.3	END-USER ISSUES	45
9.0	REFERENCES	47
APPENDIX A	POINTS OF CONTACT.....	A-1
APPENDIX B	TABLE OF COMMON ION EXCHANGE TERMS.....	A-2

LIST OF FIGURES

	Page
Figure 1.	Chemical description of a strongly basic anion exchange resin. 7
Figure 2.	Typical lead-lag carbon vessel design. 9
Figure 3.	Example of a typical counter-current regenerated ion exchange vessel. 10
Figure 4.	Typical packed-bed ion exchange vessel. 10
Figure 5a.	Schematic of vessel (normal operation). 11
Figure 5b.	Schematic of vessel (service mode). 11
Figure 6a.	Engineering drawing of vessel skid, view #1. 12
Figure 6b.	Engineering drawing of vessel skid, view #2. 13
Figure 6c.	Engineering drawing of vessel skid, view #3. 14
Figure 6d.	Engineering drawing of vessel skid, view #4. 15
Figure 7.	Resin exhaustion and replacement process (up-flow water service). 16
Figure 8.	Pilot column employing proposed vessel design. 17
Figure 9.	WVWD, Well # 11. 24
Figure 10.	City of Colton, Dominick Reservoir and Wells #15 and #17 treatment system. 24
Figure 11.	City of Rialto, Well #4. 25
Figure 12.	Face piping and well connection – WVWD. 28
Figure 13.	Process flow diagram for resin loading and service vessel. 29
Figure 14.	Timeline for ESTCP demonstration project. 29
Figure 15.	Example daily log sheet for ESTCP demonstration project. 32
Figure 16.	WVWD, Cycle #1. 37
Figure 17.	WVWD, Cycle #2. 38
Figure 18.	WVWD, Cycle #3. 38
Figure 19.	City of Colton, Cycle #1. 39
Figure 20.	City of Colton, Cycle #2. 40
Figure 21.	City of Rialto, Cycle #1. 41

LIST OF TABLES

	Page
Table 1. Performance objectives.....	21
Table 2. Water analyses for ESTCP demonstration sites.....	23
Table 3. Perchlorate loading predictions for demonstration sites.....	27
Table 4. Performance criteria for ESTCP demonstration project.....	35
Table 5. Expected performance and performance confirmation methods.....	36
Table 6. Cost tracking.....	43

ACRONYMS AND ABBREVIATIONS

BV	bed volume
CADHS	California Department of Health Services
CAPEX	capital expenditure
Cl ⁻	chloride
ClO ₄ ⁻	perchlorate
DOD	Department of Defense
DVB	divinyl benzene
eq	equivalent(s)
ESTCP	Environmental Security Technology Certification Program
ft	foot (feet)
ft ²	square foot (feet)
ft ³	cubic foot (feet)
gal	gallon
gpm	gallons per minute
HCO ₃ ⁻	bicarbonate
L	liter(s)
lbs	pound(s)
MCL	Maximum Contaminant Level
MG	millions of gallons
mL	milliliter(s)
mm	millimeter(s)
µg	micrograms
Na ⁺	Sodium
NH ₄ ClO ₄	Ammonium Perchlorate
NO ₃ ⁻	Nitrate Anion
NSF	National Sanitation Foundation
OH ⁻	Hydroxide Anion
OPEX	Operating Expenditure
ppb	parts per billion
ppm	parts per million
psig	pounds per square inch gauge
SO ₄ ²⁻	Sulfate Anion

ACRONYMS AND ABBREVIATIONS (continued)

USEPA	U. S. Environmental Protection Agency
WVWD	West Valley Water District

ACKNOWLEDGEMENTS

The project team would like to thank the Environmental Security Technology Certification Program (ESTCP) support staff including Andrea Leeson, Marvin Unger, and Deanne Rider for their support throughout the project.

*Technical material contained in this report has been approved for public release.
Mention of trade names or commercial products in this report is for informational purposes only;
no endorsement or recommendation is implied.*

This page left blank intentionally.

EXECUTIVE SUMMARY

Three demonstrations of the utilization of a novel vessel design and operating practice combined with a highly-perchlorate-selective ion exchange resin were undertaken at three municipalities, the West Valley Water District (WVWD), the City of Colton, and the City of Rialto, in Southern California. The vessel design combined a lead vessel operated in up-flow mode followed by a polishing vessel operated in down-flow mode. The design provided the capability to remove contaminated resin from the bottom of the lead vessel with replacement of the exhausted resin by uncontaminated resin remaining at the top of the lead vessel and addition of fresh media at the top of the lead vessel. The objective of the three demonstrations was to offer lower perchlorate removal costs to water utilities and government sites. Demonstration units at each of the three provided treated water containing <6 parts per billion (ppb) perchlorate concentration during operation. Three operational cycles were completed only at the WVWD. Flow balancing issues limited the City of Colton demonstration to two cycles, while several different operational setbacks allowed only one cycle at Rialto. All three units exhibited resin compaction which prevented efficient removal of the ion exchange media from the lead vessel, but resin compaction did not cause overall operational failure of any of the systems. Another difficulty involved the accumulation of a significant mass of material at the bottom of the lead vessel over a six-month operating period. This resulted from low concentrations of suspended solids in the feed water. A significant proportion of the plastic nozzles originally installed in the units broke and deformed during the demonstration and were replaced with more robust stainless steel nozzles at the conclusion of the project. While operational and equipment difficulties compromised effective contaminant removal to some degree, they did not obviate the economic benefit of the technology. Capital and site preparation costs of approximately \$275,000/unit should prove very affordable. Average total annual operating costs were estimated at approximately \$77,000/unit with total resin replacement costs of about \$110,000 recommended once every three years.

OBJECTIVES OF THE DEMONSTRATION

It is the objective of this project to demonstrate a novel vessel design and operating practice which can fully utilize the capacity of highly perchlorate selective ion exchange resin while mitigating other operational problems that often result in premature resin replacement. This was done at three municipalities in Southern California (City of Rialto, City of Colton, and WVWD) at full-scale (1250 gallons per minute [gpm]). In addition to minimizing cost, this vessel design is both small in footprint and low in profile, which is beneficial for aesthetics as many of the wells are located in residential areas.

TECHNOLOGY DESCRIPTION

In this application, the key design criteria are focused around the linear velocity of water through the ion exchange bed and the bed depth. The velocity needs to be sufficient to maintain the ion exchange bed in a packed state (against the upper nozzle plate) when running in the up-flow mode. For anion exchange resin of this type, this linear velocity is approximately 10 gpm per square foot (ft²) of cross-sectional area. For an eight-foot diameter vessel (50 ft² cross-sectional area), this flow rate is about 500 gpm. If the linear velocity is too low and fluidization of the ion exchange bed occurs, poor contact between the liquid and the beads could allow perchlorate ion

to pass through the bed without being removed. Also, the rate at which perchlorate ions can migrate from the bulk liquid phase into the resin is partially dictated by the linear velocity of the water through the ion exchange bed. Higher flow rates are favorable for low concentrations of solute but shorten the time this solute is in contact with the ion exchange resin. Balancing these two variables typically results in a “mass transfer zone,” which is the portion of the ion exchange bed through which the ion of interest is being removed from the water. It can be described by a linear distance over which the concentration of the ion of interest goes from the influent concentration to zero. As long as this mass transfer zone is shorter than the bed height, the ion exchange process can be employed. When the mass transfer zone is longer than the available resin bed, leakage of the unwanted ion out of the ion exchange bed will occur. It is easy to manage the velocity of water through the bed for a given flow rate by adjusting the diameter of the bed to give the desired velocity. One can then set the bed depth to manage the tradeoff between run length and pressure drop. Higher bed depths will give longer run lengths at the expense of higher pressure drops.

DEMONSTRATION RESULTS

Results from a 3-cubic foot (3 ft³) pilot program are discussed in a technical paper entitled, “Development of a Highly Selective Ion Exchange Resin for Removal of Perchlorate from Groundwater.”^a In addition, this article describes the validation of a proprietary computer model as a predictive tool for resin performance. In this trial, a single nozzle was employed in the top and bottom of the column and a 1-inch unscreened central lateral with ¼-inch holes was installed. A 60-inch bed depth of AMBERLITE™ PWA2 resin was added to the column. Water was introduced at a flow rate that equaled the proposed linear velocity of the full-scaled design. The bed was easily packed against the upper nozzle plate. Once the bed was packed, the valve on the central lateral was opened, and the resin below the central lateral was removed through the holes in this lateral. When the resin level reached the central lateral, no more resin was removed from the vessel, and the resin above this lateral remained in a well-packed state. Resin removal was completed within 3 minutes.

The test sites for this demonstration were selected by Environmental Security Technology Certification Program (ESTCP). Each site has a high volume well (>1,000 gpm) on a ground water source that has shown persistent perchlorate contamination. Each city has perchlorate in the ground water at levels between 6-60 ppb. The recommended regulatory level for the state of California is 6 ppb.

The WVWD, City of Colton, and City of Rialto sites are where the demonstrations were conducted. Partial water analysis for each of the three demonstration sites were provided by the municipality. Each of the sites represents drinking water wells that have been taken out of service due to perchlorate contamination or have had treatment added to allow for distribution and sale of the water. A brief summary of the performance is below:

- WVWD achieved the required <6 ppb perchlorate in the treated water over the entire three cycles of operation.
- City of Colton achieved the required <6 ppb perchlorate in the treated water over two cycles of operation.

- City of Rialto achieved the required <6 ppb perchlorate in the treated water during one cycle of operation.
- Cycle throughput ranged from 200-320 millions of gallons (MG) (~6 months) and was not directly correlated to influent perchlorate concentration.
- Resin compaction during the cycle time compromised resin removal from the subsurface lateral and disturbed the natural chromatographic profile of the resin bed.
- Overall performances of each of the units were compromised by resin compaction and effective removal, but the economic benefit was not lost.
- Capital costs and site preparation were quite low and very affordable at approximately \$275,000 per unit. Additional costs are likely based on individual site requirements.

IMPLEMENTATION ISSUES

California Department of Health Services (CADHS) Permit: As the water produced from this demonstration project will be placed into the municipal distribution system, each participating utility must obtain a permit from the CADHS. This will include issues outside the scope of this program, such as other contaminants, disinfection practices, and analytical responsibilities. The Dow Chemical Company will not be distributing this water and, therefore, cannot be the holder of these permits.

As mandated by the National Sanitation Foundation (NSF), certification for AMBERLITE™ PWA2 as the resin used in this demonstration must be rinsed for 20 Bed Volumes (BV) (volume of resin installed in the vessel) before this water can be distributed for human consumption. This initial rinse of water will need to be discharged. It will be the responsibility of the participating Utilities to obtain the necessary permits.

As Principle Investigator, I have met with the managers of each of the participating utilities. In general, the managers were cooperative and excited about participating in this program and specific demonstration project. The biggest interest was the potential to attain the anticipated high rate of perchlorate removal in a small footprint and low profile unit. The biggest concern among each of the utilities is the CADHS permitting issues. The long term decisions to expand use of this vessel design and concept will be based on a successful demonstration that a stable, controllable, and predictable process is achievable in a single vessel as determined by CADHS.

Procurement Issues: While 8-ft diameter pressure vessels are common industrial items, they are rarely kept in inventory. All of the design elements of the vessels were practiced before, but they were not combined into one vessel design as used for these demonstrations. Thus, the project team is considering this program to use a modification of commercially-available, off-the-shelf, items. As with all lined pressure vessels of size, these items are made-to-order items and thus require up to 16-week lead time. Once demonstrated, this vessel design was fabricated by existing vessel manufacturers, and a supply infrastructure for end users already existed.

Transfer of Assets: The assets (tanks and resin) from this demonstration project were transferred to the utilities at the end of this program. These units were retrofitted with some remotely-actuated valves and minimal instrumentation to allow remote monitoring and operation

of the systems. Additionally, in order to be able to obtain a CADHS permit, a polishing vessel was provided as a safety/back-up system in the event of unexpected early breakthrough of perchlorate. This vessel has little utility if this program proves to be successful. It is slightly more expensive, but it may be more prudent to employ two of the modified vessels. The vessels can be separated into two fully functional systems once the demonstration program has been deemed successful.

1.0 INTRODUCTION

1.1 BACKGROUND

Ammonium perchlorate is used in the formulation for solid rocket fuel to propel military projectiles. This formulation has been demonstrated to be highly effective, stable under ambient conditions, and low in toxicity compared to previous liquid formulations. For these reasons, ammonium perchlorate is a very important material to our military and national security. Through handling and maintenance practices believed to be satisfactory, based on the low toxicity profile of ammonium perchlorate, this material was introduced to the environment. Because of ammonium perchlorate's solubility in water and stability, it has persisted in the environment and has migrated to aquifers in populated areas and hence entered some potable water sources. Health studies have found that perchlorate can mimic iodine in the human thyroid and potentially disrupt thyroid function (Committee to Assess the Health Implications of Perchlorate Ingestion, 2005). For this reason, many states and the United States Environmental Protection Agency (USEPA) are considering creating regulations on the amount of perchlorate allowed in drinking water.

Through litigation, much of the financial burden of removing perchlorate from the environment has fallen to the Department of Defense (DoD). As this trend is likely to continue, it is important that the most cost effective method for removing perchlorate from drinking water be identified and employed. This project will demonstrate the most cost effective method of employing ion exchange to remove low levels of perchlorate from drinking water. A highly-perchlorate-selective ion exchange resin was used in a novel vessel, designed to fully utilize the resins' capacity while minimizing operational problems encountered with current lead-lag, dual vessel systems. While this project employed resin on a once-use basis, the vessel design was successfully used for external regeneration operating models. It was not suitable for in-situ resin regeneration.

1.2 OBJECTIVES OF THE DEMONSTRATION

It was the objective of this project to demonstrate a novel vessel design and operating practice that can fully utilize the capacity of highly perchlorate selective ion exchange resin while mitigating other operational problems that often result in premature resin replacement. This was done at three municipalities in Southern California (City of Rialto, City of Colton, and West Valley Water District [WVWD]) at full-scale (1250 gallons per minute [gpm]). In addition to minimizing cost, this vessel design is both small in footprint and low in profile, which is beneficial for aesthetics as many of the wells are located in residential areas.

1.3 REGULATORY DRIVERS

While no national regulations currently exist for the amount of perchlorate allowed in drinking water, several states, including California, have implemented a drinking water limit on perchlorate. The maximum contaminant level (MCL) for perchlorate in California is 6 parts per billion (ppb) and levels as low as 1 ppb have been suggested, but not implemented. Low levels of perchlorate in groundwater coupled with low MCL's will increase the number of drinking water wells that require treatment. Ion exchange has been proven to be a very effective process

technology for these conditions and was quite applicable as a well-head treatment technology based on effectiveness, cost, and scalability.

2.0 TECHNOLOGY DESCRIPTION

2.1 TECHNOLOGY/METHODOLOGY OVERVIEW

Ammonium perchlorate (NH_4ClO_4) is both extremely soluble in water and very stable. In solution, it will exist as a soluble salt of perchlorate anion (ClO_4^-) and a counter cation, depending on the ambient ground water. As perchlorate exists as a charged anion, it can be removed from solution by ion exchange technology.

Ion exchange resins are insoluble polymer beads that have the ability to reversibly exchange ions. The beads are in the range of 0.35 millimeter (mm) to 1.1 mm in diameter and typically used in packed beds of 24 inch to 72 inch in depth. Most commercial ion exchange resins used in water treatment are made of a copolymer of styrene and divinyl benzene (DVB) that is functionalized to fix the exchange site to the copolymer backbone. Strongly acidic cation exchange resins possess a sulfonic acid exchange site, while strongly basic anion exchange resins possess a quaternary amine exchange site. Strong basic anion exchange resin was employed in this demonstration program. Figure 1 shows the chemical composition of a standard strongly basic anion exchange resin.

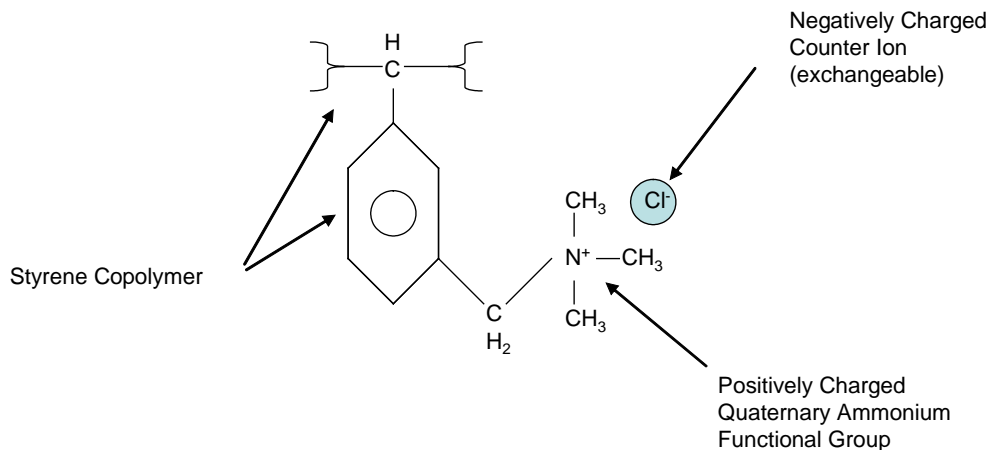

Figure 1. Chemical description of a strongly basic anion exchange resin.

In regenerable applications, the exchangeable ion is determined by the choice of regenerating reagent. Due to thermodynamic considerations that will not be discussed here, ion exchange resins have a higher selectivity for some ions over others. A typical, strong, basic anion exchange resin has the following selectivity profile:



It is this difference in selectivity that allows ion exchange resin to be used to remove low levels of one ion in the background of higher concentrations of another ion. The physical and chemical composition of the ion exchange resin can be manipulated to affect this relative selectivity. In the case of this demonstration project, the resin employed was developed to have a very high selectivity for perchlorate ion. This is marketed commercially as AMBERLITE™ PWA2. It should be noted that the perchlorate-selective ion exchange resin being used in this project has

been utilized commercially for perchlorate removal. Hence, the resin is not the focus of this demonstration. It is the single vessel design and the way in which the design maximized the use of the ion exchange resin on which we will concentrate in this demonstration. In this application, the exchange reaction can be written as:

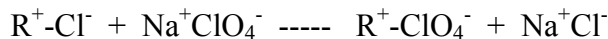

In this case, sodium ion (Na^+) was used to represent the counter-ion to maintain electrical neutrality in the chemical equation. R represents the immobile ion exchange site bound to the resin copolymer.

The selectivity for this resin is as follows:



The current practice for employing ion exchange resin for the removal of perchlorate from drinking water is to use standard activated carbon service vessels in a lead-lag configuration (two vessels in series) with a minimum of 3-feet (ft) of bed depth per vessel. When the lead vessel is exhausted, the polishing vessel is placed in the lead position, the resin in the lead vessel is replaced with fresh resin, and this vessel is placed in the polishing position. These vessels are typically 10-12 ft in diameter with a 7-8 ft straight side. They also employ vertical strainers mounted in the bottom dish to retain the resin inside the vessel. These vertical strainers result in poor distribution of water over the media and inefficient use of this media. In addition, these vessels are used in a down-flow mode with water entering the top of the vessels and exiting to bottom. This operational mode has two deficiencies. First, the long operating time in the down-flow mode tends to compact the resin and increase pressure drop. Second, there is a tendency to build up suspended solids on the top of the bed. Both of these issues require backwash of the resin bed to mitigate the effects. This backwashing can fluidize the ion exchange bed and disturb the resin loading profile. In this manner, some of the resin that is saturated in perchlorate can end up residing in the bottom of the vessel, near the exit. This results in increased leakage and potentially premature resin replacement. Figure 2 is a schematic of standard activated carbon vessels employed in the lead-lag configuration. Additionally, the use of two large vessels requires a larger footprint, has a higher profile, and utilizes more resin (greater pressure drop and pumping costs) than the proposed technology.

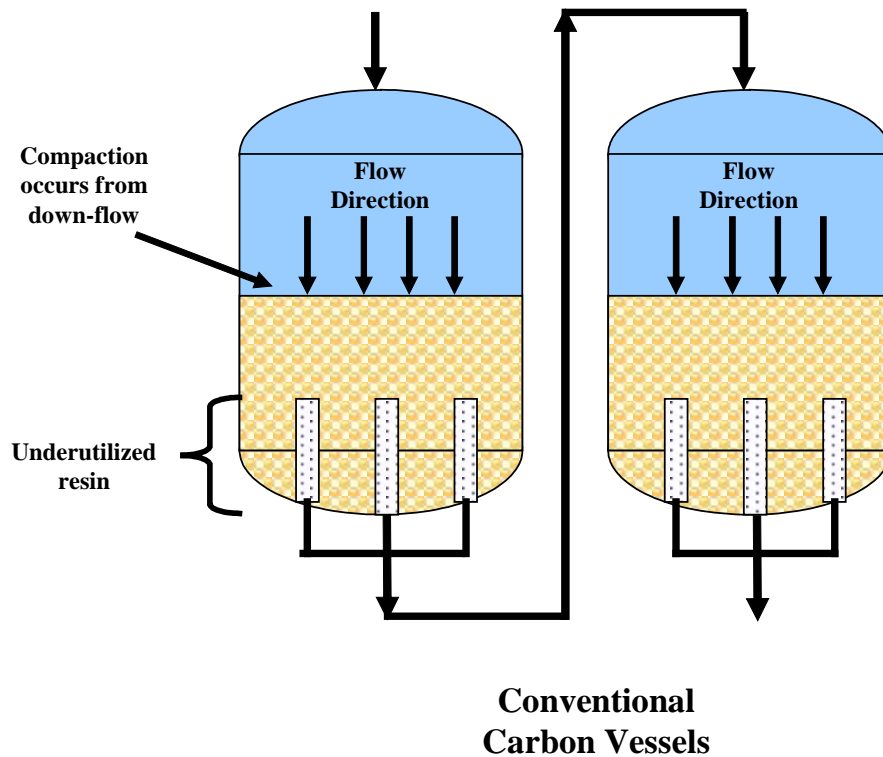

Figure 2. Typical lead-lag carbon vessel design.

Counter-current regenerated ion exchange systems were developed in the 1950s to decrease leakage of unwanted ions and to increase chemical efficiency. Previously, only co-current regenerated ion exchange systems existed. In a co-current regenerated system, the flow direction of the service cycle and the regeneration cycle are the same, i.e., down-flow. During regeneration, the top of the resin bed always sees the virgin regeneration solution while the bottom of the bed sees a mixture of diluted regenerant and liberated ions from the regeneration process. Thus, the bottom of the bed is less regenerated than the top and contains an inventory of unwanted ions that “leak” off the resin during the subsequent service cycle. A counter-current regenerated system uses opposite directions for the service cycle and the regeneration cycle. In this manner, the resin at the exit (top) of the bed during the service cycle is the resin at the entrance to the bed during the regeneration cycle. Thus, it is the resin that sees the virgin regenerant solution and is highly regenerated. Because the resin has a very low inventory of unwanted ions present during the subsequent service cycles, “leakage” of unwanted ions is very low. The key tenet of these counter-current systems was to maintain the ion profile of the ion exchange resin bed so highly regenerated resin would always be present at the exit of the bed to polish the treated water to very low levels of unwanted ions. Also, any partially exhausted resin would reside at the entrance to the bed. The early systems employed down-flow service cycles and up-flow regeneration with either a downward “blocking” flow of water or air to hold the bed in a packed state during regeneration. In either case, a mid-lateral was employed to remove liquid from the system at a place that was neither the top nor the bottom of the vessel. A further refinement to this design was the split-flow, counter-current regenerated system. In this design, the mid-lateral was placed below the surface of the resin bed such that the top of the resin bed was regenerated in a co-flow manner and the bottom of the bed was regenerated in a counter-current manner. Figure 3 is a schematic of this type of counter-current regenerated ion exchange

bed. Finally, the reverse-flow, counter-current regenerated, packed-bed demineralizer was developed. This design used fixed nozzle (strainer) plates to keep the resin profile intact and removed the need for an internal mid-lateral. It also employed up-flow service and down-flow regeneration. Figure 4 is a schematic of a typical packed-bed, ion exchange vessel. In the 1960's, the mixed bed demineralizer was developed. This employed two types of ion exchange resin (cation and anion exchange resin) in the same bed. These resins needed to be separated prior to regeneration and then the respective fractions needed to be held in position during regeneration as not to allow cross-contamination of the resin.

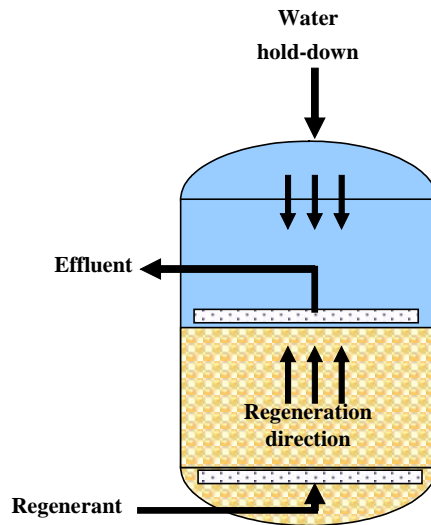

Figure 3. Example of a typical counter-current regenerated ion exchange vessel.

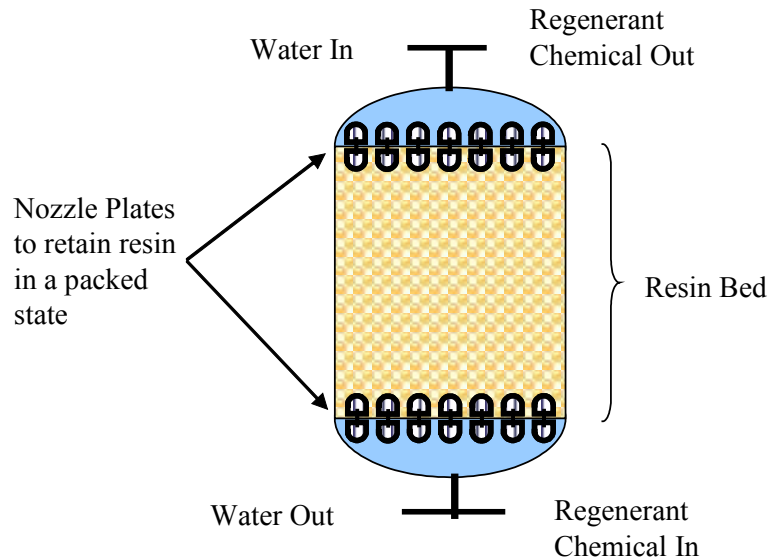

Figure 4. Typical packed-bed ion exchange vessel.

Elements of each of these technologies were drawn upon to create a vessel design which would optimize the use of once-use resin. Figures 5a and 5b show a schematic of this vessel design. The design is based on a reverse-flow, packed-bed system. The resin (five-foot bed depth) is

contained between two fixed, flat nozzle plates, and in this manner the resin loading profile is maintained intact. Up-flow operation allows bed decompaction during any disruption of flow, thus reducing the need to backwashing to reduce bed compaction. An unscreened central internal lateral is used to remove the bottom (exhausted) portion while the top portion of the bed is retained intact. While in the service mode (Figure 5b) with water flowing up and packing the bed against the upper nozzle plate, the valve on the unscreened central lateral is opened. Resin below this lateral is flushed out of the system and is collected for disposal while all resin above this central lateral remains in the vessel, packed against the upper nozzle plate. After the exhausted resin has been removed from the bed, the top layer of resin is allowed to fall to the bottom (entrance) and fresh resin can be added to the top to create a new polishing zone. This allows lead-lag operation inside a single vessel. Figures 6a, 6b, 6c, and 6d show the basic engineering drawings of the vessel to be used on this demonstration project. Figure 7 shows the various stages of operation and how the resin bed is managed to remove the exhausted resin while keeping the fresh resin in the vessel.

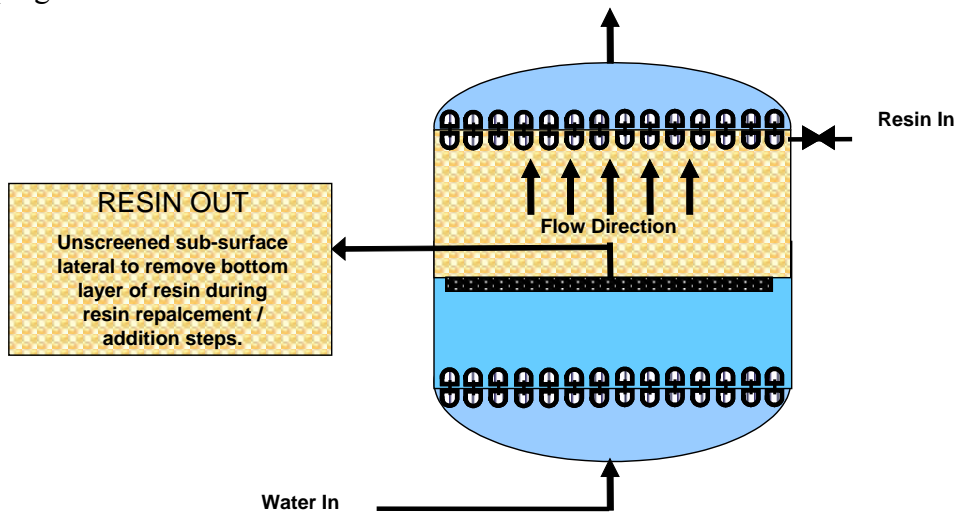

Figure 5a. Schematic of vessel (normal operation).

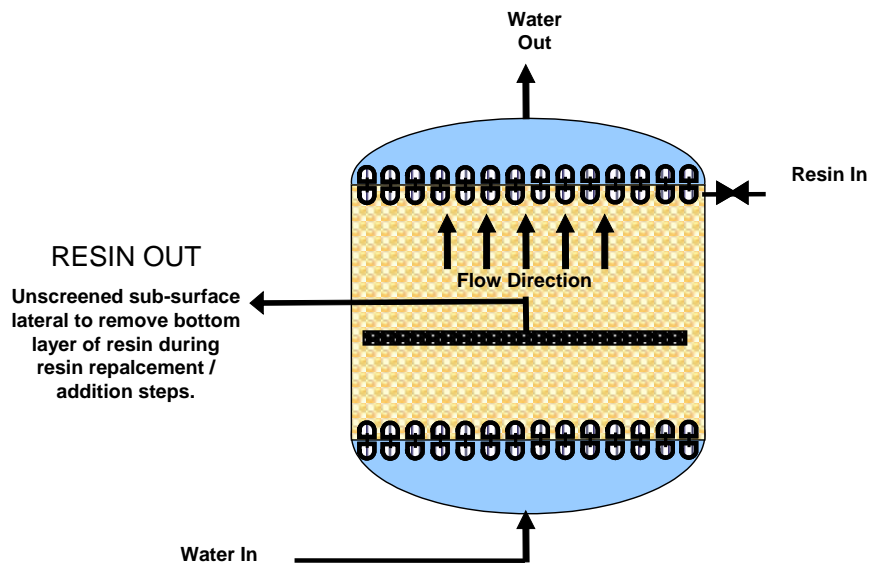

Figure 5b. Schematic of vessel (service mode).

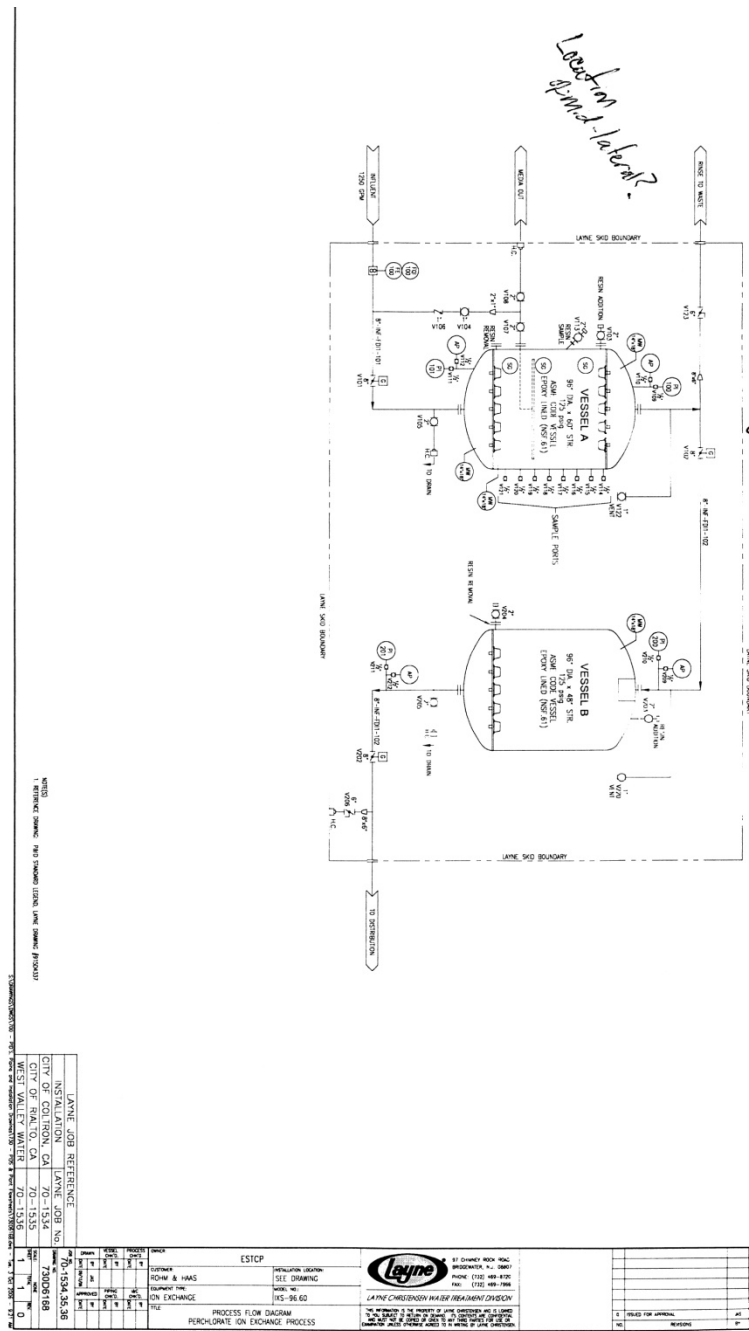

Figure 6a. Engineering drawing of vessel skid, View #1.

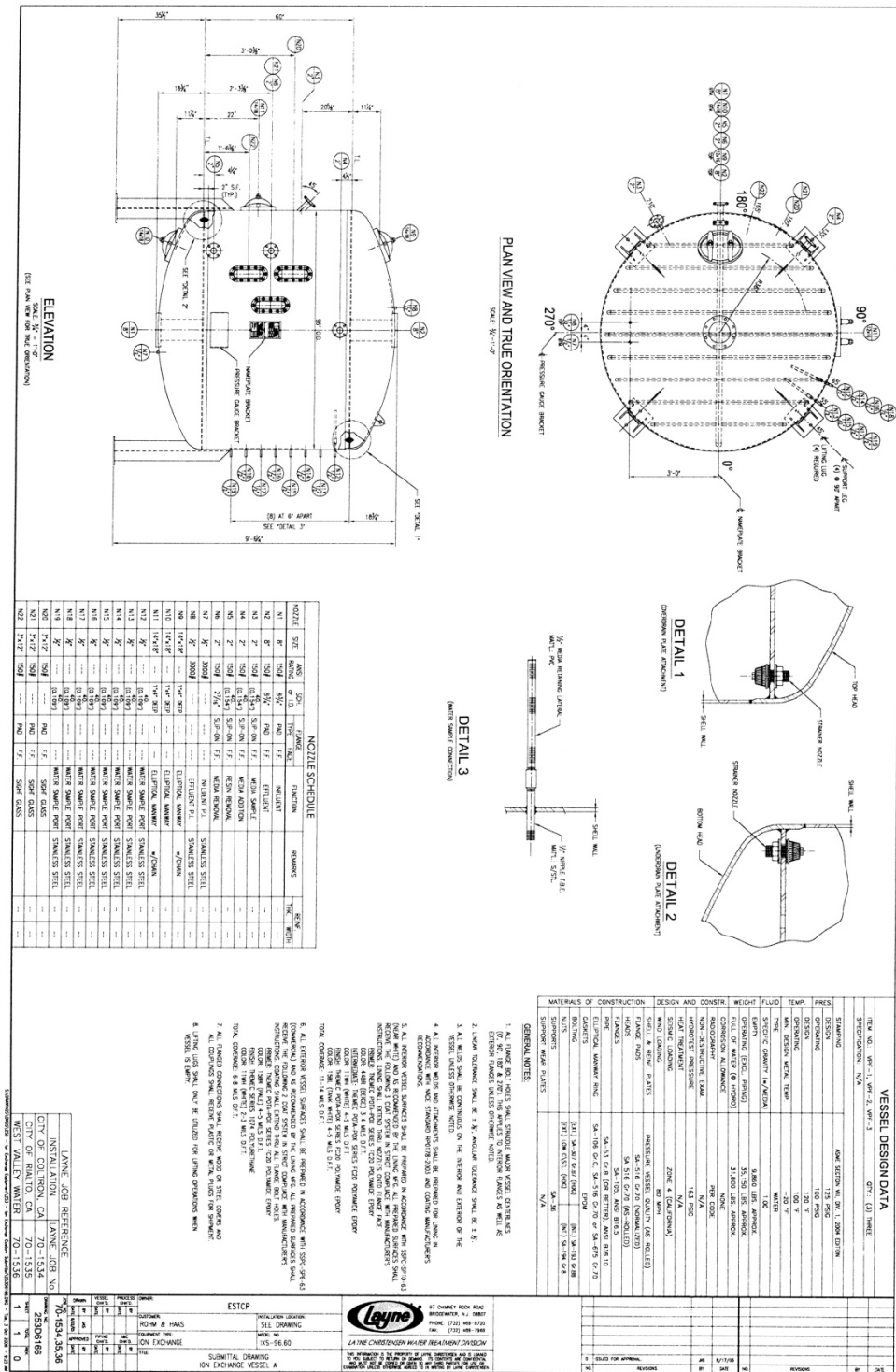

Figure 6c. Engineering drawing of vessel skid, View #3.

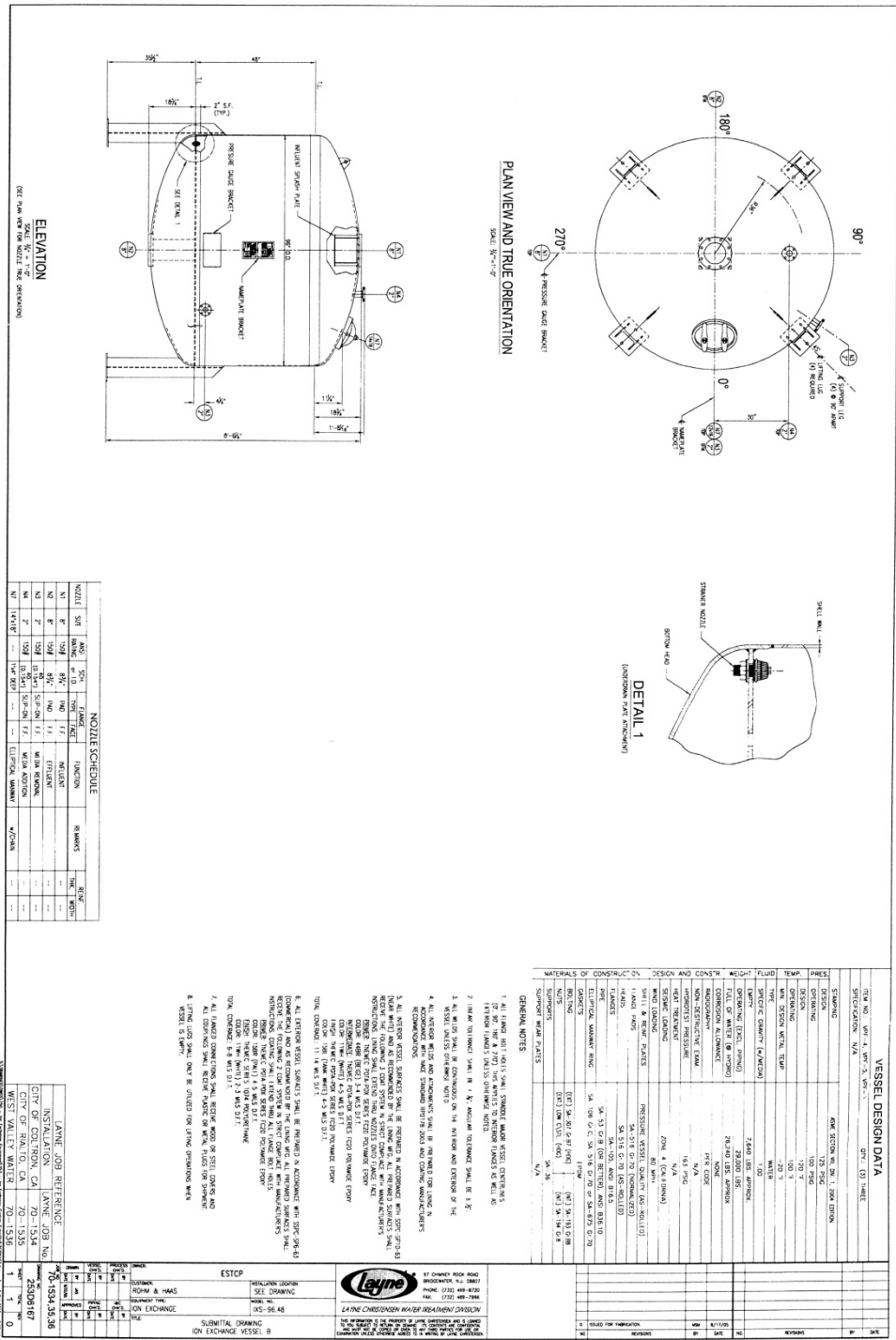

Figure 6d. Engineering drawing of vessel skid, View #4.

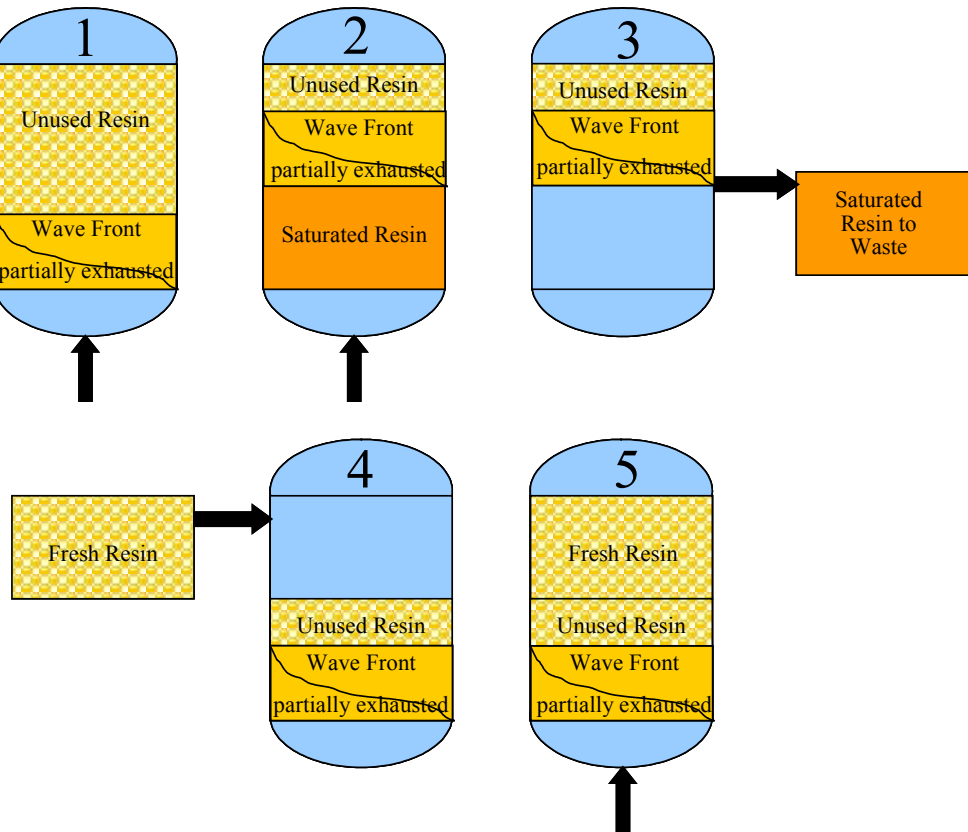

Figure 7. Resin exhaustion and replacement process (up-flow water service).

In this application, the key design criteria are focused around the linear velocity of water through the ion exchange bed and the bed depth. The velocity needs to be sufficient to maintain the ion exchange bed in a packed state (against the upper nozzle plate) when running in the up-flow mode. For anion exchange resin of this type, this linear velocity is approximately 10 gpm/square foot (ft²) of cross-sectional area. For an 8-ft-diameter vessel (50 ft² cross-sectional area), this flow rate is about 500 gpm. If the linear velocity is too low and fluidization of the ion exchange bed occurs, poor contact between the liquid and the beads could allow perchlorate ion to pass through the bed without being removed. Also, the rate at which perchlorate ions can migrate from the bulk liquid phase into the resin is partially dictated by the linear velocity of the water through the ion exchange bed. Higher flow rates are favorable for low concentrations of solute but shorten the time this solute is in contact with the ion exchange resin. Balancing these two variables typically results in a “mass transfer zone”, which is the portion of the ion exchange bed through which the ion of interest is being removed from the water. It can be described by a linear distance over which the concentration of the ion of interest goes from the influent concentration to zero. As long as this mass transfer zone is shorter than the bed height, the ion exchange process can be employed. When the mass transfer zone is longer than the available resin bed, leakage of the unwanted ion out of the ion exchange bed will occur. It is easy to manage the velocity of water through the bed for a given flow rate by adjusting the diameter of the bed to give the desired velocity. One can then set the bed depth to manage the tradeoff between run length and pressure drop. Higher bed depths will give longer run lengths at the expense of higher pressure drops.

2.2 TECHNOLOGY DEVELOPMENT

AMBERLITE™ PWA2 has been used commercially at the Lincoln Avenue Water Company and has been shown to be capable of removing perchlorate to below detection level. Results from a 3-cubic-foot (ft³) pilot program are discussed in a technical paper entitled, Development of a Highly Selective Ion Exchange Resin for Removal of Perchlorate from Groundwater (Carlin et al, 2004). In addition, this article describes the validation of a proprietary computer model as a predictive tool for resin performance.

Figure 8 shows four photographs from a 6-inch-diameter pilot column employing the proposed design. In this trial, a single nozzle was employed in the top and bottom of the column and a 1-inch unscreened central lateral with ¼-inch holes was installed. A 60-inch bed depth of AMBERLITE™ PWA2 resin was added to the column. Water was introduced at a flow rate that equaled the proposed linear velocity of the full-scaled design. The bed was easily packed against the upper nozzle plate. Once the bed was packed, the valve on the central lateral was opened, and the resin below the central lateral was removed through the holes in this lateral. When the resin level reached the central lateral, no more resin was removed from the vessel, and the resin above this lateral remained in a well-packed state. Resin removal was completed within 3 minutes.



6" Pilot column
before flow
applied



Up- flow
applied. Resin
is packed
against upper
header plate.
Mid-lateral can
be seen on left.



Resin being
removed
through
unscreened
mid-lateral.



Resin transfer
complete.
Upper portion
of bed still in
packed state.
Lower portion
removed
completely.

Figure 8. Pilot column employing proposed vessel design.

2.3 ADVANTAGES AND LIMITATIONS OF THE TECHNOLOGY

The key factor affecting the cost of the system will be the management of the upper portion of the ion exchange bed during the removal of the lower exhausted portion. Removing unexhausted

resin will result in higher resin use than anticipated and reduce the benefit of the design. There is also the obvious factor of resin capacity, which has the major effect on the cost. This, however, has been well studied and the predictive model has been validated making this issue less of a risk and concern for the success of the demonstration.

Another factor affecting the overall cost performance equation is resin disposal. The used ion exchange media in this system, as well as many other systems of similar design, is disposed of in a properly approved facility (landfill or incineration). The cost of this disposal has not been prohibitive and has not detrimentally affected the economics of using ion exchange technology for perchlorate removal from drinking water sources.

Advantage: Compared to the lead-lag ion exchange process, the primary advantage of the technology being demonstrated is ion exchange resin utilization. While some lead-lag systems may allow full saturation of the lead bed, practical experience has shown that most lead beds are replaced for reasons other than perchlorate saturation, e.g., pressure drop due to compaction of suspended solids loading. The secondary advantage is the small footprint for the water utility, which allows deployment of this technology to locations in neighborhoods and locations with limited land.

Advantage: Chromatographic peaking of perchlorate has not been an issue with ion exchange technology because most of the resins employed have a high selectivity for perchlorate. However, equilibrium leakage of perchlorate at quantities higher than the effluent specification can occur if the resin containing perchlorate is located near the exit of the vessel. In the case of lead-lag systems, the resin loading profile in the polishing vessel is not disturbed. Thus, the perchlorate inventory in the bed is not redistributed toward the exit, and equilibrium leakage has not been an issue. With the proposed vessel design, some resin turbulence and mixing will occur when the upper portion of resin is allowed to fall into the bottom of the vessel after resin removal (from the bottom portion). During the 6-inch pilot column tests, it was observed that after the transfer of the lower portion of the ion exchange bed, the upper portion of the bed “fell” to the bottom over a period of a couple of minutes in a manner that mixed small portions of resin from the same general area of the bed, but did not create significant turn-over of the beds such that resin that was at the bottom of this portion of the bed ended up at the top. Thus, in general, the relative “order” of the resin was intact after it was allowed to “fall” into the bottom of the column. It is expected that this minor redistribution will not impact the overall resin utilization or the perchlorate leakage from the vessel.

Advantage: The other prominent technologies applied to perchlorate removal include biological treatment via fixed-, fluidized-, and membrane-bioreactors and surfactant modified activated carbon (referred to as “tailored carbon.”) As an overall technology, ion exchange is a very robust and predictive technology. It is governed by the laws of thermodynamics and kinetics and, thus, is well modeled. Biological processes rely on the control of a live system and require addition of substrates to the water to keep the biological system active and healthy. Ion exchange has a long history of safe use in potable water treatment and results in little health risk to the public. Biological systems present the possibility for contamination of drinking water with undesirable microorganisms.

Advantage: While modified activated carbon has been shown to be effective, not enough is known about its long term performance, cost, and robustness to make an accurate comparison to ion exchange resin.

Advantage: Compared to other ion exchange based systems, the primary advantage of this technology is that it is designed to minimize the cost-per-unit of perchlorate removed. While capital cost and resin cost may be higher than other approaches, life-cost and unit cost should be lower. Additionally, the small footprint, low profile, and scalability make this an attractive alternative for wellhead treatment in residential areas or where space is limited or at a premium.

Limitation: A limitation of the technology is more frequent resin change-outs. Also, most lead-lag systems employ large amounts of resin, and the resin change-out procedures and infrastructure have been established to remove these large resin quantities. A more efficient method and infrastructure for smaller and more frequent resin change-outs will need to be established in the marketplace.

This page left blank intentionally.

3.0 PERFORMANCE OBJECTIVES

The key performance objective for the demonstration is to offer lower perchlorate removal costs to water utilities and U.S. Government sites. This is achieved if perchlorate levels exiting the primary treatment vessel can be maintained below the stated target of 6 ppb and the resin utilization can be maximized. Thus, perchlorate leakage and overall resin utilization are the key performance criteria for this demonstration and system design. This is governed by the ability to maintain the resin bed integrity with respect to perchlorate exhaustion profile during periods of discontinuous operation (start/stop) and resin change-outs. It should be noted that this demonstration project examined resin utilization as it pertains to single-use/throw-away operation.

Table 1. Performance objectives.

Type of Performance Objective	Performance Criteria	Performance Metrics	Actual Performance
Quantitative	1. Meets drinking water standard for perchlorate	Perchlorate content out of primary vessel <6 ppb, CA recommended regulatory level	Meets
	2. Utilizes resin capacity	Calculated and measure capacity utilization \geq predicted from computer model	Meets
	3. Effectively separates exhausted resin from fresh (polishing resin)	Measurement of calculated perchlorate mass versus measured perchlorate mass on resin removed from system	Adequate*
	4. Yields acceptable pressure drops	Pressure drop measured over course of demonstration <4 psig/ft	Meets
	5. Ease-of-use/robust	System stays operational – >98% asset utilization	Meets
Qualitative	6. Meets drinking water standard for organics	Does not impart organics to water as measured by state lab	Meets or Exceeds
	7. Reduces treatment cost	Resin utilization and separation results in calculated treatment cost < current cost	Meets

*Adequate performance means resin separation and removal was achieved, however at this scale, was more difficult than what was experienced in the pilot study.

psig = pounds per square inch gauge

This page left blank intentionally.

4.0 FACILITIES/SITE DESCRIPTION

The test sites for this demonstration were selected by ESTCP. Each site has a high volume well (>1000 gpm) on a ground water source that has shown persistent perchlorate contamination. Each city has perchlorate in the ground water at levels between 6-60 ppb. The recommended regulatory level for the state of California is 6 ppb.

The partial water analysis for each of the three demonstration site is listed in Table 2. Each of the sites represents drinking water wells that have been taken out of service due to perchlorate contamination or have had treatment added to allow for distribution and sale of the water. Figures 9, 10, and 11 show photographs of the WWWD, City of Colton, and City of Rialto sites (respectively) where the demonstrations will take place.

Table 2. Water analyses for ESTCP demonstration sites.

Ion	Units	Site		
		Rialto #4	WWWD #11	Colton #15
ClO ₄ ⁻	ppb	60-90	6	5
SO ₄ ²⁻	ppm	7	73	73
Cl ⁻	ppm	4	14	14
NO ₃ ⁻	ppm	12	40	40
HCO ₃ ⁻	ppm as CaCO ₃	150	180	180

ppm = parts per million

It should be noted that the nitrate levels for the waters at the WWWD and the City of Colton sites are near the MCL. The perchlorate selective resin (AMBERLITE™ PWA2) being used for this demonstration also exhibits high selectivity for nitrate. Because perchlorate is the only significant ion to displace nitrate loaded on the resin and the perchlorate ion concentration is quite low, nitrate spiking, i.e., elution of nitrate at levels greater than the MCL, did not occur.

4.1 FACILITY/SITE LOCATION AND OPERATIONS

Only the City of Colton site has existing perchlorate removal treatment on the well. This is a conventional system as described previously. Current operating and cost data was not readily available.



Figure 9. WWWD, Well # 11.



Figure 10. City of Colton, Dominick Reservoir, and Wells #15 and #17 treatment system.



Figure 11. City of Rialto, Well #4.

This page left blank intentionally.

5.0 TEST DESIGN

5.1 PRE-DEMONSTRATION TESTING AND ANALYSIS

For each of the chosen sites, a computer simulation was run to predict the throughput for each bed. The predictive model utilized is proprietary to The Dow Chemical Company and is not publically available. These data appear in Table 3. Resin capacity as measured by the total mass of perchlorate ion removed for each cycle (concentration x volume) will be measured against this prediction as a key performance criterion. It should be noted that the ion exchange resin being used in this demonstration project (AMBERLITE™ PWA2) has a very steep perchlorate equilibrium isotherm. This means that the perchlorate loading capacity of the resin (R-ClO₄) to equilibrium saturation increases sharply as the perchlorate content of the challenge water increases. This results in the resin having little sensitivity with respect to throughput (i.e., volume of water treated) based on varying amounts of perchlorate in the influent.

Table 3. Perchlorate loading predictions for demonstration sites.

Loading Estimate To Full Equilibrium	Units	PWA2	PWA2	PWA2
		Rialto #4	WVWD #11	Colton #15
R-ClO ₄	equivalents/liter (L)	0.092	0.013	0.013
Loading	pounds (lb)/ft ³	0.570	0.083	0.083
Throughput	gallons (gal)/ft ³	3,793,353	1,657,652	1,657,652

5.2 CONCEPTUAL DESIGN AND BASELINE CHARACTERIZATION

The conceptual design and baseline characterization were articulated in Section 2.0 Technology Description.

5.3 DESIGN AND LAYOUT OF TECHNOLOGY COMPONENTS

The system design and lay of the technology components were articulated in Section 2.1 Technology/Methodology Overview.

5.4 OPERATIONAL TESTING

5.4.1 DEMONSTRATION SET-UP AND START-UP

Site Preparation – The perchlorate removal systems supplied for this demonstration are designed to be temporary, transportable, and to minimize demonstration cost to ESTCP. For this reason, they are designed with minimal site preparation required and no automated instrumentation or control. Site preparation included:

- Preparing a graded crushed stone base to place the treatment skids.
- Connection from the well pump and to the water distribution system.
- Development of the ability to discharge water to the appropriate waste outlet for times when the wells must be run to clear suspended solids from the system.

The treatment systems used mechanical flow meters so no electrical connections were necessary.

Equipment Mobilization and Installation - The vessels are skid mounted, each with its own frame as shown in Figure 6d. Some face piping will be left off the system for shipping purposes. Each system was delivered by flat-bed truck and off-loaded by a small crane on site. Once off-loaded and sited, interconnecting piping was installed in the field, and the system will be connected to the well feed pump and the drinking water distribution piping with manual shut-off valves used to isolate the system as depicted in Figure 12. No bypass is included because it is assumed these wells cannot be used for public consumption without treatment.



Figure 12. Face piping and well connection – WVWD.

System Start-up (Shakedown) – Before operation began, all necessary California Department of Health Services (CADHS) permits were obtained by the participating utilities. Once installed, the well pumps were run to drain until the water runs clear of any visible suspended solids. The vessels were then filled with water to leak test the piping. When the piping and valves were leak tested and tightened as necessary, one-half of the water was drained from the system, and new ion exchange resin was loaded into the vessels using the custom resin loading system shown in Figure 13. When the proper amount of resin was loaded in each vessel, a 20-bed volume (of resin installed) rinse of the resin was conducted in accordance with National Sanitation Foundation (NSF) protocols for AMBERLITETM PWA2, perchlorate selective ion exchange resin.

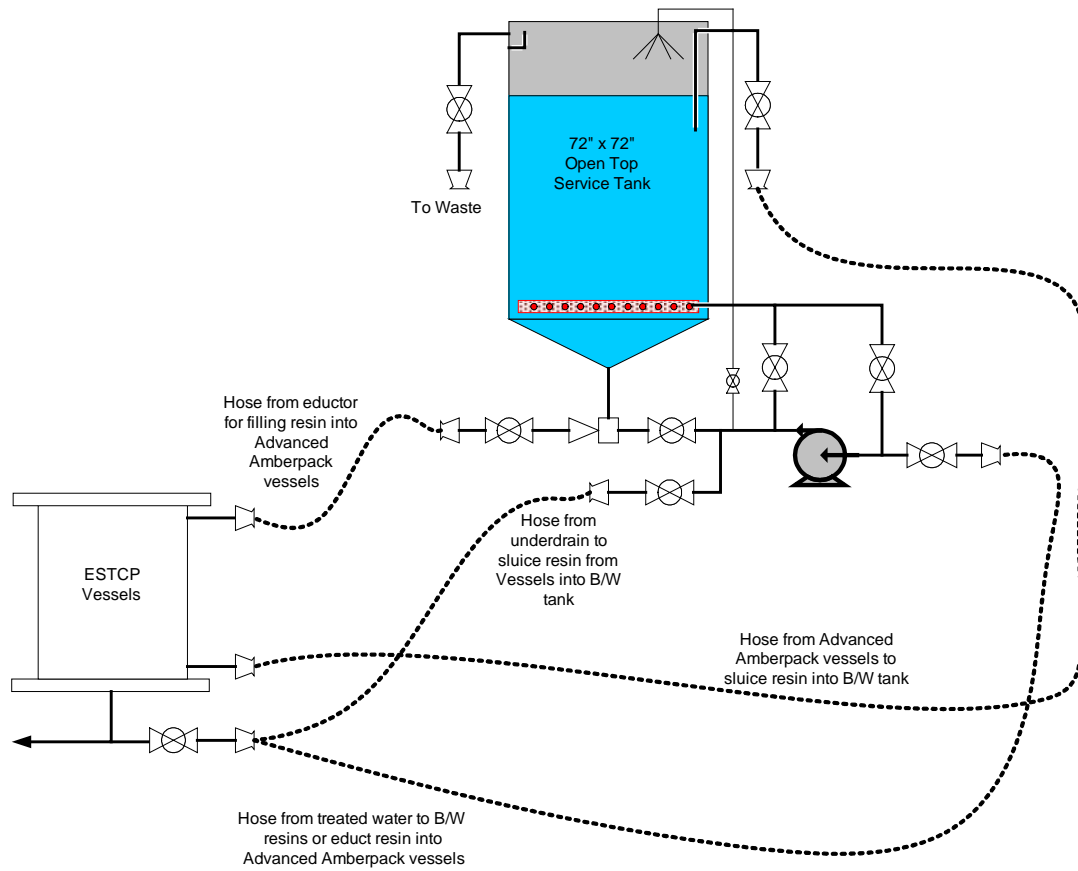

Figure 13. Process flow diagram for resin loading and service vessel.

5.4.2 PERIOD OF OPERATION

An anticipated program timeline is presented in the Gantt chart in Figure 14. This schedule applied to all three sites, depending when each water purveyor obtained a CADHS permit to distribute this water for sale.

ESTCP Perchlorate Demonstration Project - Anticipated Timeline														
Activity	2008								Years 2010-2012					
	May	Jun.	Jul.	Aug.	Sep.	Oct.	Nov.	Dec.	1H2010	2H2010	1H2011	2H2011	1H2012	2H2012
CADPH Permitting	[Bar spanning May-Dec 2008]													
Start-up									Start-up [Bar spanning 1H2010-2H2010]					
Cycle 1 loading									Loading Cycle 1 [Bar spanning 1H2010-2H2010]					
Resin Change-out									Replace Resin [Bar spanning 2H2010-1H2011]					
Cycle 2 loading									Load Cycle 2 [Bar spanning 1H2011-2H2011]					
Resin Change-out									Replace Resin [Bar spanning 2H2011-1H2012]					
Cycle 3 loading									Load Cycle 3 [Bar spanning 1H2012-2H2012]					
Complete samples									Samples [Bar spanning 1H2010-2H2012]					
Data Analysis									Data Analysis [Bar spanning 2H2010-1H2012]					
Technical report									Tech Report [Bar spanning 1H2012-2H2012]					
Cost analysis									Cost Report [Bar spanning 1H2012-2H2012]					

Figure 14. Timeline for ESTCP demonstration project.

5.4.3 TREATMENT RATE

The systems were designed to treat 1250 gpm of groundwater. Higher flow rates were achieved but at the expense of pressure drop. A lower limit on flow rate was estimated to be 500 gpm. Below this flow rate, the risk of fluidizing the bed became an issue.

5.4.4 RESIDUALS HANDLING

There were two expected residuals from this demonstration (1)water, and (2)used ion exchange resin. Water that was used for rinsing new resin, slurring resin into or out of the vessels, or run to clear due to suspended solids must be disposed of in a manner that is approved by the state of California and the local regulators. This water was sent to nearby drains or retention basins. Spent ion exchange resin that was loaded with perchlorate was disposed of by incineration under a service contract with Siemens Industries, Inc. Both were consistent with currently performed best practices and were acceptable to both state and local authorities.

5.4.5 OPERATING PARAMETERS FOR THE TECHNOLOGY

The key operating parameters were flow rate and volume treated. These parameters were measured via a mechanical flow meter with data manually recorded periodically. While there was no upper limit on the flow rate from a perchlorate removal stand point, the upper limit was bounded by the capability of the well pump and the pressure drop across the system. Flow rates below 500 gpm were avoided because these would result in fluidization of the ion exchange bed, which could allow perchlorate to escape the primary demonstration vessel.

The system was designed to operate continuously, but it can accept periodic shutdowns. Because of its simplicity, the system is basically either “on” or “off” which is defined by when the well pump was running. No “operation” per se is required. However, those involved with producing water from these wells were educated on the process, the program, and given a set of emergency instructions and contacts should the system need to be taken out of service for any reason.

There was little that is required between resin change-outs under normal operation. Water samples were taken on at least a weekly basis and measured for perchlorate content. In this manner, the rate at which the resin was exhausting can be monitored and resin change outs scheduled appropriately. The perchlorate concentrations and the volume of water treated was used to calculate the mass of perchlorate removed by the system and, thus, the economics of the process.

5.4.6 EXPERIMENTAL DESIGN

This program was designed as a demonstration of a system design and operation at full-scale. As such, the operating parameters did not vary significantly to determine system response to variables and operating ranges. The program will:

- Defined the perchlorate exhaustion profile for a packed bed of ion exchange resin;
- demonstrated that a defined and fixed portion of that bed can be controllably removed;
- showed that a new exhaustion profile can be reestablished by the addition of fresh resin.

In this manner, the lead-lag aspects of the traditional two vessel approach can be accomplished in one low profile vessel. This will be repeated for three partial exhaustion cycles.

The perchlorate exhaustion profile was established based on multiple water samples taken along the height of the ion exchange bed. In this case, the sampling taps are located every 6 inches up the straight side of the vessel, as well as on the inlet and outlet of the primary and polishing vessels. These sampling taps extended 12 inches into the resin bed to assist in getting a representative sample. The sampling procedure is described in Section 5.5. By measuring the perchlorate content of this water as a function location (height) in the bed and as a function of throughput, the shape of the exhaustion profile (mass transfer zone) was determined and its progress through the ion exchange bed could be monitored. A computer simulation program was used to estimate when the resin will become exhausted. These results appear in Table 3, expressed as pounds $\text{ClO}_4^-/\text{ft}^3$ of resin to complete exhaustion and converted to throughput (gallons) per ft^3 of resin based on the concentration of perchlorate in the water. In the case of the WVWD site, this number is 1,657,652 gal/ ft^3 . The objective was to exhaust and remove 100 ft^3 of resin per cycle. The target was to get 11 water sample sets during this time period. Thus, water sampling occurred every 15,000,000 gal or approximately every 8 days during the first cycle, which assumed the system is continuously operated at the design flow rate of 1250 gpm. The first cycle is lasted approximately 90 days.

$$100 \text{ ft}^3 \text{ resin} \times \frac{1,657,652 \text{ gal}}{\text{ft}^3 \text{ resin}} \times \frac{1}{11 \text{ sample sets}} = \frac{15,069,563 \text{ gal}}{\text{sample set}}$$

$$\frac{15,069,563 \text{ gal}}{\text{sample set}} \times \frac{\text{minutes}}{1250 \text{ gal}} \times \frac{\text{hours}}{60 \text{ minutes}} \times \frac{\text{day}}{24 \text{ hr}} = \frac{8.37 \text{ days}}{\text{sample set}}$$

The mass of perchlorate removed by this 100 ft^3 of resin is calculated from the difference in perchlorate concentration between the inlet and the sample tap corresponding to the 100 ft^3 of resin employed over the loading cycle, multiplied by the total treatment volume. During resin change-outs, a composite sample of the exhausted resin may be taken. This material will be stripped of perchlorate in the laboratory, and the mass of perchlorate recovered will be compared to the calculated mass of perchlorate removed as a way to verify the mass balance for perchlorate.

The ability for the system to handle multiple starts and stops was monitored by recording each time the system was started and stopped and relating the corresponding water sampling data to each event to determine if the perchlorate loading zone was disturbed during these start-stop events. An elongated mass transfer zone, compared to initial results, is a sign that resin is getting redistributed in the system during start-stop operation. If the system is being run on a steady basis for the first two resin loads, a forced start-stop period will be conducted and the results observed and recorded.

The ability for the system to handle minor suspended solids load was determined by the pressure drop across the system during each of the loading cycles. There was also an opportunity to visually observe the lower portion of the resin bed during the resin transfer/replenishment operations.

5.4.7 PERFORMANCE MONITORING

Data Collection: The primary data was perchlorate content of the water at all points in the system and the volume of water treated for these corresponding samples. These data were generated from analysis of water samples taken on a regular basis from multiple points in the system. A mechanical flow meter on the inlet to the system will display the instantaneous flow rate and measure volumetric throughput. The date, time, instantaneous flow rate, and throughput was recorded on a daily basis by Utility personnel. Figure 15 shows a sample data collection sheet for this information. P1 is the inlet pressure to the system. P2 refers to the intermediate pressure between the demonstration and safety polishing vessels. P3 corresponds to the outlet of the safety polishing vessel. At approximately eleven evenly spaced intervals throughout each cycle, water samples were collected from all sample ports and sent to the laboratory for perchlorate analysis. Some samples were tested for other common and interfering ions such as nitrate and sulfate. Figures 5a and 5b (see page 11 above) shows the schematic drawing of the treatment system and the location of the sample points. The timing of these samples was determined by the computer model predictions for run length (throughput) and amended, as needed, by field data and experience as the program proceeds. Water samples were collected by plant operators into 125 milliliter (ml) polyethylene sample bottles and sealed. As perchlorate and the other common inorganic salts are very stable, no special preservatives or handling procedures were required for these samples. In addition to the samples taken for the demonstration program, routine samples required by the state of California to distribute this drinking water were taken by the water utility and submitted to a state approved laboratory in accordance with USEPA, CADHS, and any other local regulatory requirements.

ESTCP Demonstration Program System Log Sheet								
Location _____								
(Record Date and Time for ALL starts and stops of this system)								
Date	Time	Throughput (gallons)	Flow rate (gpm)	P1	P2	P3	System Status and Observations	Operator

Figure 15. Example daily log sheet for ESTCP demonstration project.

Experimental Controls: The primary baseline data are the inlet water analysis and the outlet water quality at the initial time (t=0). Inlet water samples were taken with each sample set. This is not a side-by-side comparison study to other technologies or other configurations of ion

exchange resin. Thus, comparisons for performance and cost must come from independent sites and independent tests. One of the test sites (City of Colton) has an operating perchlorate removal system using ion exchange resin with the traditional carbon vessel configuration. This provided a good opportunity to compare the demonstration unit with a conventional unit for size, performance, and cost. Available data will be gathered from the utility and used as baseline data for competing technologies.

Analytical/Testing Methods: Analytical/Testing Methods are described in detail in Appendix A of the Final Technical Report.

Ion Exchange Resins: The ion exchange resin, used in this demonstration project, came from commercial stock. As such, it was manufactured and tested using standard Rohm and Haas Company Quality Control and Quality Assurance methods and practices. The lot number for each batch of ion exchange resin employed was recorded in the site log book and in the electronic file belonging to the Principal Investigator.

5.5 SAMPLING PROTOCOL

The sampling protocol followed for data acquisition is articulated in the Section 5.4.7 Performance Monitoring.

5.6 SAMPLING RESULTS

Sample results are shown in Section 6 Performance Assessment.

This page left blank intentionally.

6.0 PERFORMANCE ASSESSMENT

6.1 PERFORMANCE CRITERIA

Table 4 describes, in detail, the performance criteria used to evaluate the performance of the perchlorate treatment technology in this demonstration project. “Primary” criteria directly address the project’s performance objectives.

Table 4. Performance criteria for ESTCP demonstration project.

Performance Criterion	Description	Primary or Secondary
Contaminant Reduction	The system must achieve perchlorate effluent below the CA proposed limit of 6 ppb from primary vessel. Target is <1.0 ppb	Primary
Resin Separation	System must be able to effectively separate exhausted resin from unexhausted resin.	Primary
Resin Utilization	Primary vessel should maximize the use of the ion exchange resin. The target is >95% utilization of exchange capacity.	Primary
Cost	The total capital expenditure (CAPEX) and operating expenditure (OPEX) must be below current market prices to be successful/valuable.	Primary
Breakthrough Predictability	Demonstrate the ability to monitor the location and rate of change of the perchlorate breakthrough front (mass transfer zone).	Secondary
Ease-of-Use	The partial replacement of ion exchange resin must be fast, effective, simple and reliable.	Secondary
Robust Process	The system must be able to handle frequent start-stop events without resulting in premature breakthrough.	Primary
Solids Handling	It will be beneficial if the system can tolerate some suspended solids loading as this makes the process robust and reduces pretreatment requirements.	Secondary
Overall Ease and Robustness	The overall ease of ownership should be high. This is based on installation, start-up, operation, and change-outs.	Secondary

6.2 PERFORMANCE CONFIRMATION METHODS

As illustrated the performance criteria, metrics and methods utilized to evaluate the demonstration.

Table 5. Expected performance and performance confirmation methods

Performance Criterion	Expected Performance Metric (pre-Demonstration)	Performance Confirmation Method
Contaminant reduction	Reduce ClO_4^- to below 1 ppb from primary vessel	Measure ClO_4^- in effluent by ion chromatography (method described in Appendix A of the Final Report)
Resin separation	Will remove >95% of fully exhausted resin (below mid-lateral) and retain >95% of the unexhausted resin (above the mid-lateral).	1) Mass balance on ClO_4^- during each cycle using ion chromatography and resin elution technique. 2) Measuring volume of resin removed. 3) Measure initial ClO_4^- distribution and mass transfer zone upon restart after resin replacement.
Resin Utilization	Will utilize >95% of the applied ion exchange capacity	1) Mass balance of ClO_4^- over each cycle using ion Chromatography. 2) Direct measure of ClO_4^- eluted from exhausted resin.
Cost	Calculated costs based on CAPEX quotation(s) and demonstrated OPEX will be lower than current contract costs for ClO_4^- removal.	Detailed cost calculations based on demonstration project data.
Robust process	The process will tolerate start-stop operation without decrease in resin utilization and premature perchlorate breakthrough.	Position and shape of perchlorate breakthrough curve (mass transfer zone) will be monitored as a function of frequency and timing of start-stop intervals. Same methods as used for “Resin Utilization”
Breakthrough predictability	A clear and predictable perchlorate breakthrough curve (mass transfer zone) will be able to be identified and mapped in the ion exchange bed as a function of run time and perchlorate flux (mass loading in $\mu\text{g/L}^*$)	The data generated to determine resin utilization will be plotted to define perchlorate breakthrough curve (mass transfer zone) through each loading cycle.
Ease-of-use	The system will be easy to load, easy to operate, and easy to change resins with no special operator attention or expertise.	An operator log will be kept to record any excursions in operations and detailed notes and photos will be taken during resin change outs to characterize and record the ease-of-operation/use.
Solids handling capability	The system will be able to handle a small amount of suspended solids without significant disruption to service.	Suspended solids will be measured on the incoming water during each cycle and the pressure drop across the system will be observed, recorded, and monitored during these loading cycles.

6.3 DATA ANALYSIS, INTERPRETATION AND EVALUATION

The critical data are the concentration of perchlorate in equilibrium with each fraction of ion exchange resin along the height of the bed, including the effluent. These data come directly from the measurement of perchlorate in the water samples taken at intervals throughout each cycle at specified volumetric throughputs. The perchlorate concentration is plotted as a function of bed height and volume throughput for each set of samples. In this manner, a “graphical picture” of the shape and progression of the exhaustion wave front (mass transfer zone) can be attained. From this picture, the resin utilization is determined and also ascertains the impact of any process upsets such as frequent start-stop operation. The redistribution of perchlorate containing resin

after each resin transfer can also be seen in this manner. This redistribution and the total mass of perchlorate eluted from the resin removed from the system will enable a mass balance on perchlorate to be obtained and, hence, the efficiency of the vessel design toward resin management.

6.4 WVWD – PERFORMANCE DATA

WVWD Well #11 system demonstration occurred from January 11, 2010, through May 10, 2011. No significant operational issues prevented timely completion of this demonstration and, with great support from WVWD employees during the demonstration period, all operations were monitored very closely. Resin compaction did result in limited ability to remove the resin required between cycles and disrupted the natural chromatographic distribution of perchlorate loading on the media. There is no doubt that this affected the unit from operating optimally; however, the data would suggest that the unit did perform adequately. The data from the three performance cycles at WVWD are shown below in Figures 16, 17 and 18. These data show the perchlorate concentration in the lead bed at various points along the straight side of the vessel at six-inch increments versus the volumetric throughput in millions of gallons (MG) and the date the samples were taken.

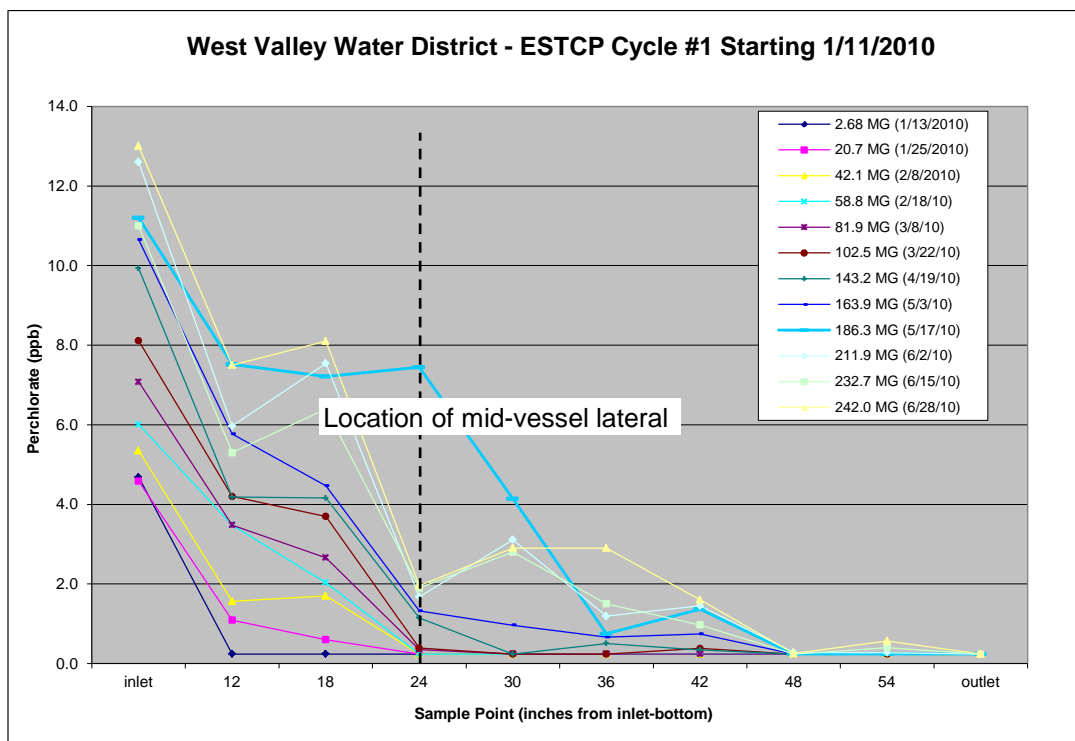

Figure 16. WVWD, Cycle #1.

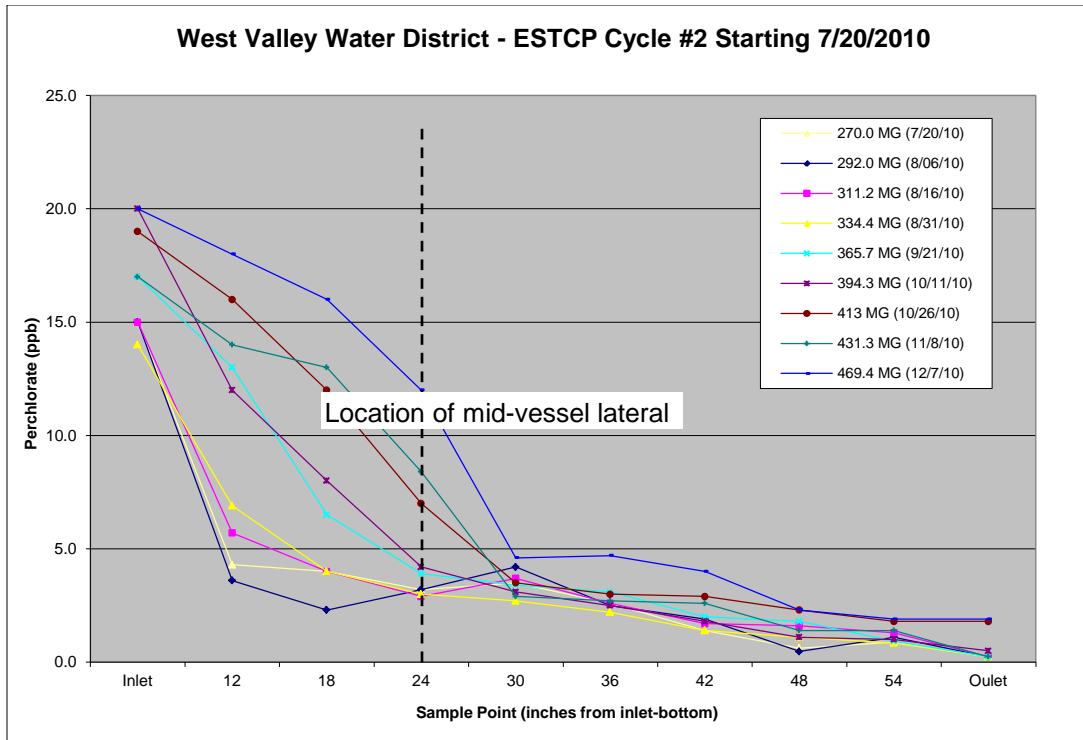

Figure 17. WVWD, Cycle #2.

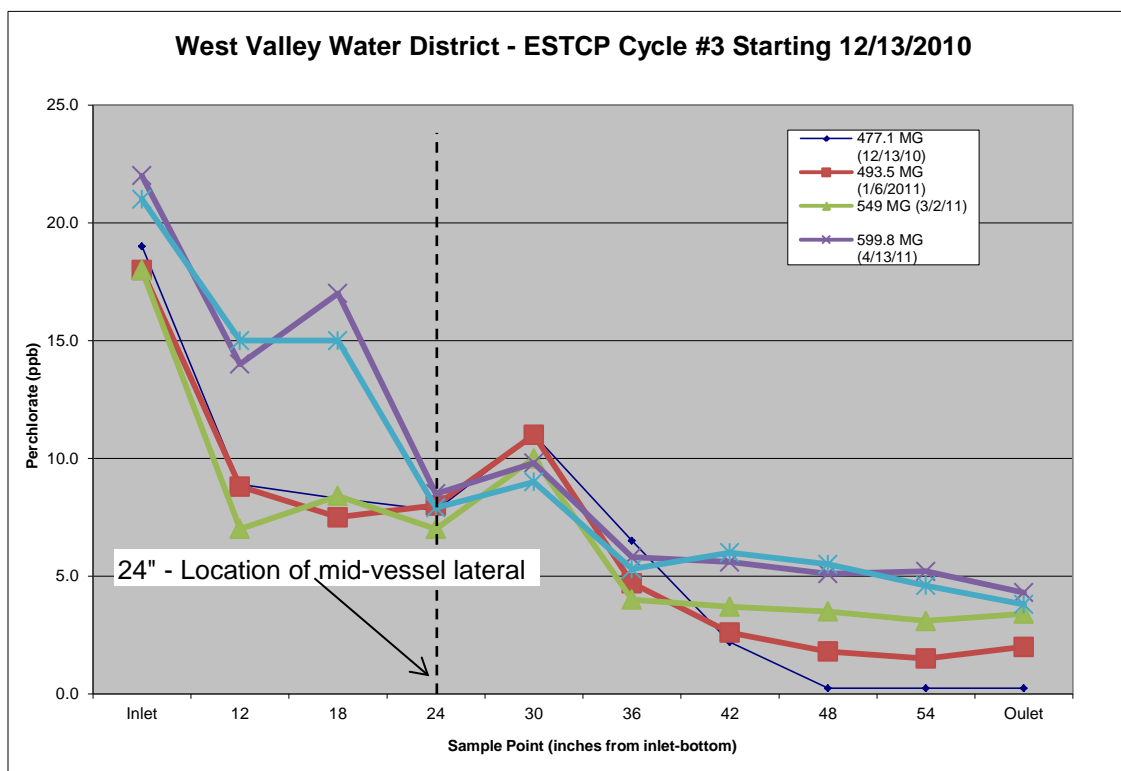

Figure 18. WVWD, Cycle #3.

6.5 CITY OF COLTON – PERFORMANCE DATA

The City of Colton demonstration at Wells #15 and #17 encountered flow balancing issues after the first cycle of operation. The demonstration unit is tied into the feed header of an existing perchlorate removal system, and due to normal hydraulic balancing the demonstration unit regularly was starved of water. Other issues during the demonstration period, including broken nozzles, plugged nozzles, compacted resin and well pump issues, resulted in sporadic operation and data acquisition. The data below cover two cycles of operation from July 26, 2010, to March 19, 2012. Due to limited achievable flow of water to the demonstration unit, a third cycle of operation has been delayed indefinitely. The performance data are shown in Figures 19 and 20.

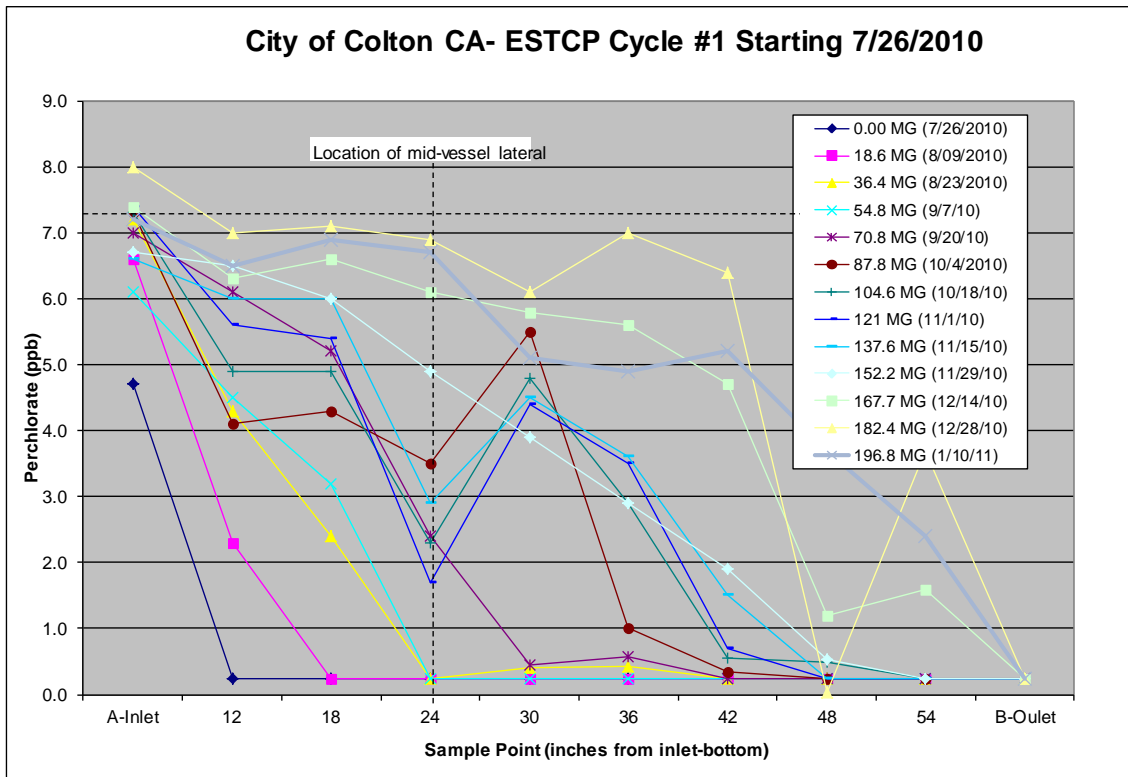

Figure 19. City of Colton, Cycle #1.

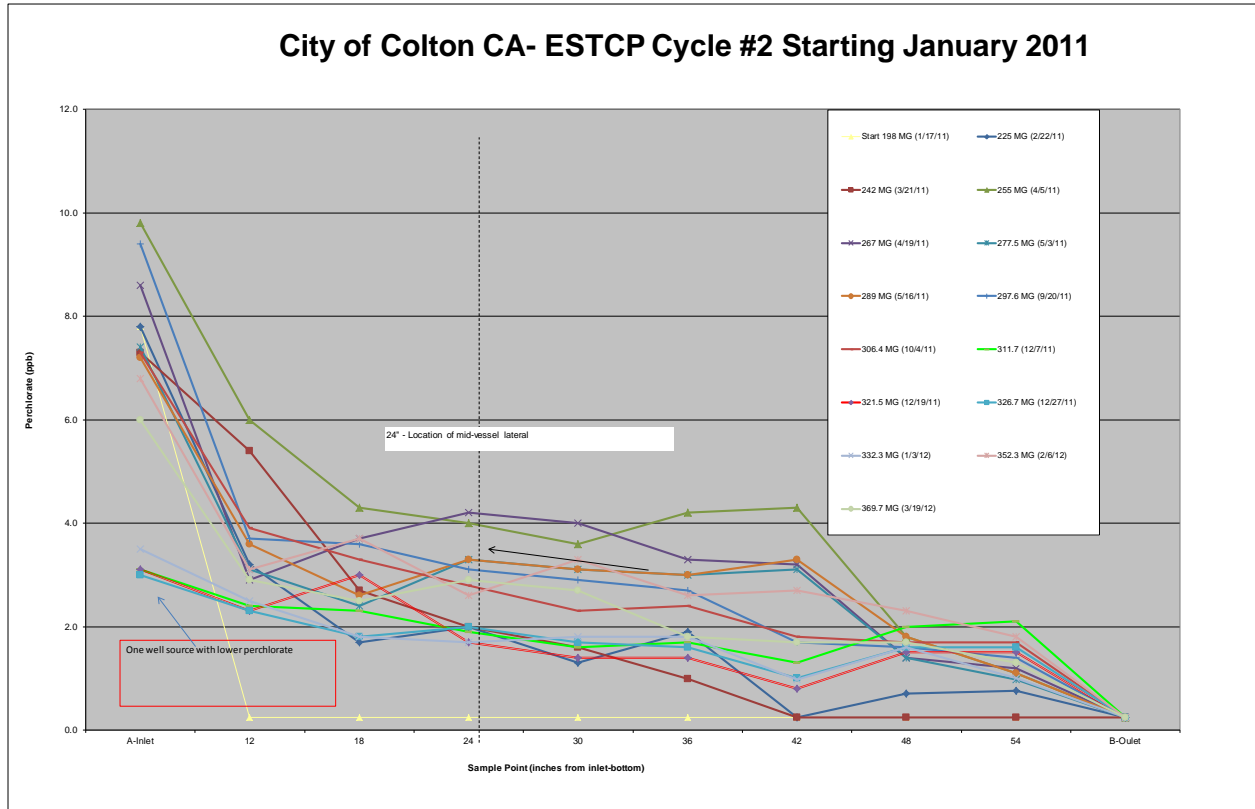

Figure 20. City of Colton, Cycle #2

6.6 CITY OF RIALTO – PERFORMANCE DATA

City of Rialto Well #4 demonstration site encountered multiple operational setbacks during the proposed operational period. There was a water rights dispute with neighboring municipalities, plus the demonstration unit was not permitted for producing potable water. All water produced during operation was discharged to a low-lying retention pond adjacent to the well site and was not conducive to significant in-service operations. Due to these circumstances, the operation of the unit and data collected were sporadic at best. Below are the data for this site, shown in Figure 21.

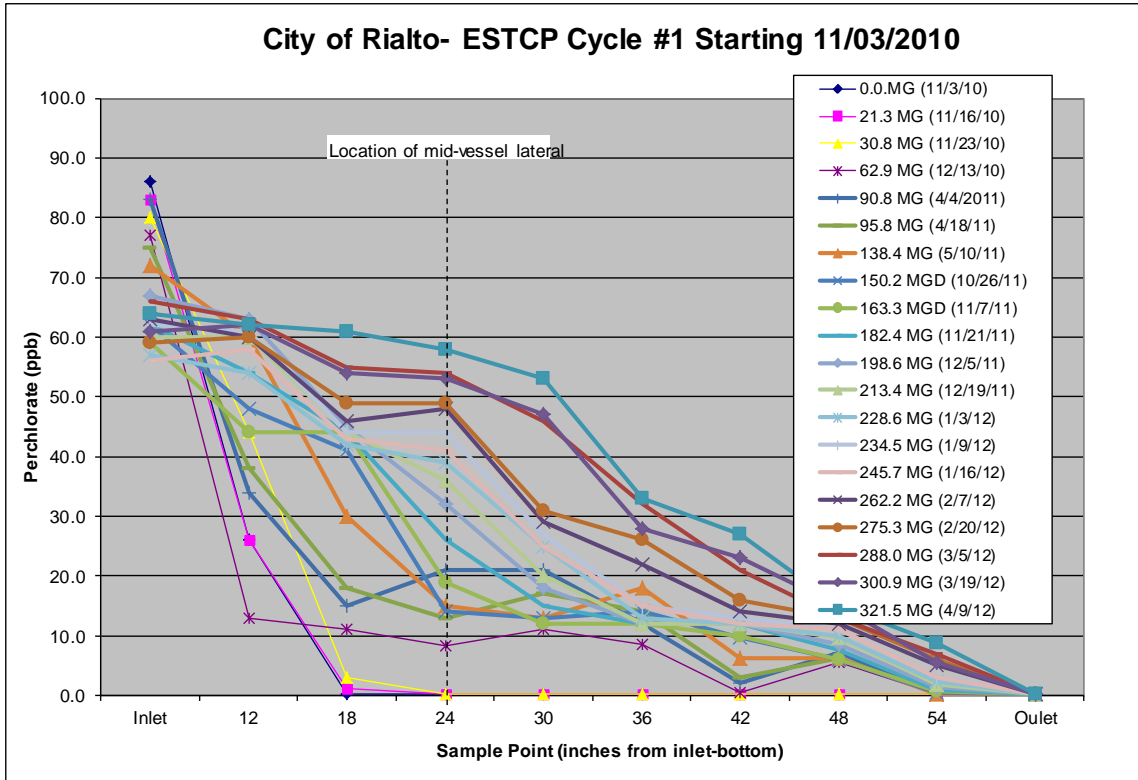

Figure 21. City of Rialto, Cycle #1.

This page left blank intentionally.

7.0 COST ASSESSMENT

7.1 COST MODEL

Cost reporting will be as per the Table 6.

Table 6. Cost tracking.

Cost Category	Sub-Category	Details	Unit	Unit Price	Usage	Total Cost
Capital costs	Capital equipment					\$435,000
	Site Works					\$370,000
	Installation	Manpower	Man-hours			
		Supplies				
Rentals						
Start-up costs	Manpower	Manpower	Man-hours	\$250	80	\$20,000
	Other Services	Disinfection Biological Testing				\$2000
Operating cost	Water sampling	See below	Man-hours			
	Supplies	Bottle				\$1000
	Other services	Repairs/ Upgrades				\$329,000
Resin costs	Initial fill	Resin	ft ³	\$325	978	\$317,850
	1st change-out	Resin	ft ³	\$325	200	\$65,000
	2nd change-out	Resin	ft ³	\$325	100	\$32,500
Resin changes	Manpower	Manpower	Man-hours	\$250	48	\$12,000
	Other services					
	Disposal cost	Resin	ft ³	\$100	820	\$82,000
Analytical	Water samples	Each	No. samples			\$32,000
	Resin samples		No. samples			\$0
	Regulatory. samples		No. samples			\$0

7.2 COST ANALYSIS

Cost Comparison: In the concentration range of interest (roughly 4-200 ppb ClO₄⁻), the only commercially applied technology is ion exchange. All these systems use the standard carbon vessel design, which we believe is inefficient in resin utilization.

Cost Basis: The primary cost comparison is based on the combination of capital cost, resin utilization, resin exchange, and disposal costs. Where possible, these costs were extracted from commercial systems and contracts. Many perchlorate removal systems are operated on a service basis where the water utility pays on a volume-treated basis with some baseline costs or are based on guaranteed throughput per unit.

Cost Drivers: As the perchlorate selective resin used in this demonstration project (AMBERLITE™ PWA2) is relatively insensitive to perchlorate concentration with respect to resin utilization, the primary cost drivers were the impacts of abnormal operations on resin utilization. These included frequent on-off cycling of the system and suspended solids in the feed

water. The latter should be considered a separate contaminant issue. Pressure drop also had an impact on cost. Deeper beds resulted in more pressure drop and, thus, more energy usage to pump the water. However, deeper beds also decreased the frequency of resin replacements, saving on man-power and service fees.

Life Cycle Cost: As this was a full scale demonstration over a significant period of time, determining life cycle costs was straight forward exercise. The capital cost was amortized over a ten-year period, and the operating costs were directly proportional to the costs from the demonstration project.

8.0 IMPLEMENTATION ISSUES

8.1 ENVIRONMENTAL CHECKLIST

CADHS Permit: As the water produced from this demonstration project will be placed into the municipal distribution system, each participating utility must obtain a permit from the CADHS. This will include issues outside the scope of this program, such as other contaminants, disinfection practices, and analytical responsibilities. Rohm and Haas Company did not distributed this water, and therefore was not the holder of these permits.

As mandated by the NSF certification for AMBERLITETM PWA2, the resin used in this demonstration must be rinsed for 20 Bed Volumes (BV) (volume of resin installed in the vessel) before this water can be distributed for human consumption. This initial rinse of water will need to be discharged. It is the responsibility of the participating utilities to obtain the necessary permits.

8.2 OTHER REGULATORY ISSUES

One meeting was held with CADHS in person and one by teleconference to discuss the design, the system, and the program. Joint meetings with each participating Utility and the local CADHS office were needed to finalize permitting requirements and plans.

8.3 END-USER ISSUES

Meetings were held with the managers of each of the participating utilities. In general, they were cooperative and excited about participating in this program and specific demonstration projects. The biggest interest is in the potential to attain the anticipated high rate of perchlorate removal in a small footprint and low profile unit. The biggest concern among each of the utilities is the CADHS permitting issues. The long term decisions to expand use of this vessel design and concept will be based on a successful demonstration that a stable, controllable and predictable process is achievable in a single vessel as determined by CADHS.

Procurement Issues: While 8-ft-diameter pressure vessels are common industrial items, they are rarely kept in inventory. While all of the elements of the design of our vessels have been practiced before, they were not combined into one vessel design as we are using them. Thus, we were considering this program to use a modification of commercially-available, off-the-shelf, items. As with all lined, pressure vessels of size, these items were made to order items and thus require up to 16-weeks lead time. This vessel design was fabricated by existing vessel manufacturers, and a supply infrastructure for end users already exists.

Custom Service Vessel: A custom service vessel is being designed for use in the resin transfer operations. This will make the resin transfers easy and enable them to be completed without liquid discharges. This tank will be built and owned by the service company conducting the resin change outs (Layne Christensen), but the design can be offered to the participating Utilities should they wish to buy or build such a service vessel for their own use after this program. This service vessel will be skid mounted and mobile.

Transfer of Assets: The assets (tanks and resin) from this demonstration project will be transferred to the utilities at the end of this program. These units have been designed as fully manual units to keep demonstration costs to ESTCP down, and the units may not be in a readily usable form when transferred. These units should be retrofitted with some remotely-actuated valves and minimal instrumentation to allow remote monitoring and operation of the systems. Additionally, in order to be able to obtain a CADHS permit, a polishing vessel is being provided as a safety/back-up system in the event of unexpected early breakthrough of perchlorate. This vessel will have little utility if this program proves to be successful. It is slightly more costly, but it may be more prudent to employ two of the modified vessels. They can be separated into two fully functional systems once the demonstration program has been deemed successful.

9.0 REFERENCES

Carlin, W.H., B.J. Hoffman, T.K. Mallmann, T.J. Peschman, Development of a Highly Selective Ion Exchange Resin for Removal of Perchlorate from Groundwater. 2004. National Groundwater Association Conference on MTBE and Perchlorate: Assessment, Remediation, and Public Policy, Costa Mesa, CA (June 3-4, 2004).

Committee to Assess the Health Implications of Perchlorate Ingestion, National Research Council. 2005. Health Implications of Perchlorate Ingestion, ISBN 0309095689.

This page left blank intentionally.

APPENDIX A
POINTS OF CONTACT

Point of Contact	Organization	Phone E-Mail	Role in Project
Jim Summerfield	Dow Water and Process Solutions 5065 StateStreet Suite 255 Saginaw, MI 48603	Phone: 989-781-0306 E-Mail: jmsummerfield@dow.com	Principal Investigator
Jay A. Miers	Dow Water and Process Solutions 100 Independence Mall West Philadelphia, PA 19106	Phone: 989-638-2241 E-Mail: JMiers@dow.com	Principal Investigator
Scott D. Boyce	Dow Chemical 727 Norristown Road Spring House, PA 19477	Phone: 215-641-7518 E-Mail: sboyce@dow.com	Co-Principal Investigator
Andrea Leeson	ESTCP Office 4800 Mark Center Drive Suite 17D08 Alexandria, VA 22350-3605	Phone: 571-372-6398 E-Mail: andrea.leeson@osd.mil	Environmental Restoration Program Manager

APPENDIX B: TABLE OF COMMON ION EXCHANGE TERMS

Bed Volume	The term bed volume in ion exchange means the three dimensional volume occupied by the ion exchange resin (including the void volume between beads) when in a settled or packed state. In a packed bed column, the ion exchange bed volume will be very close to the volume of the vessel.
Breakthrough	Breakthrough means when the contaminant of interest (in this case perchlorate ion) appears in the column effluent at values greater than the baseline “leakage” level.
Capacity	Capacity is the mass of contaminant that can be loaded onto a unit of ion exchange resin. It is typically described in terms or chemical equivalents per liter of resin. In this program, it will also describe in pounds perchlorate per cubic foot of ion exchange resin (lb/ft ³).
Chromatographic Peaking	This is when the level of a given species exiting an ion exchange column is greater than the level of that species in the feed water. This occurs when a given ionic species is removed from the feed water and concentrated on the ion exchange resin, then subsequently displaced by another species due to equilibrium (thermodynamics).
Distribution	Distribution is the dispersal of liquid over the ion exchange resin and is concerned with the percent of the resin that is exposed to a common flow.
Exhaustion	Exhaustion is the point at which the level of contaminant exiting the column is the same as the level entering the column. The resin is thus at equilibrium with the influent liquid and no further ion exchange will occur.
Fluidization	The opposite of packed. The beads move freely due to hydraulic conditions. This typically occurs when liquids are fed in an upflow direction at low flow rates. This is the state at which the flow and drag forces on the ion exchange resin equal the force of gravity.
In-situ Regeneration	Regeneration that occurs inside a fixed ion exchange column. (See Regeneration).
Ionic Profile	This is the distribution of ions that are loaded onto the ion exchange bed along the bed’s length (height in a vertical column). The ionic composition of the ion exchange resin will vary at different points along the height of the column based on the feed water composition and the equilibrium constants for a given ion exchange resin.
Lateral	This is the pipe structure inside an ion exchange column that provides “distribution” of water over the resin bed.
Leakage	This is the level of contaminant that exits the column. Equilibrium leakage is the result of the ionic composition of the resin and the ionic composition of the surrounding water. It is based on thermodynamics. The kinetic leakage is the level of ionic contaminant that is not removed during its travel through the ion exchange bed.
Linear Velocity	This is the one dimensional velocity of liquid through the column. It is typically expressed as meters per second (m/s) but can also be expressed as gpm/ft ² cross-sectional area of the column.
Loading Profile	This is the ionic profile of the ion exchange resin at any point during the loading cycle, when contaminant is being removed from the feed water.
Packed Bed	An ion exchange system where the volume of the ion exchange resin employed is very close to the volume of the vessel in which it is used.
Polishing	Polishing is the expression used when the minute remainder of a contaminant is removed by a highly regenerated portion of ion exchange resin.
Regeneration	This is the chemical act of reversing the ion exchange reaction by adding an excess of a chemical to overcome the resins selectivity for a contaminant thus removing that contaminant from the ion exchange resin and replacing it with an ion which is more favorable in the effluent of the ion exchange unit.
Regenerant	The chemical used to reverse the ion exchange reaction and remove the contaminant from the resin.
Service Cycle	The period during which contaminant is being removed from the feed water. This is opposite the regeneration cycle or replacement cycle.
Strainer	A form of liquid distributor that is used with a packed bed ion exchange unit. Strainers are typically plastic “caps” with slots in them. They are to retain the resin inside the packed bed vessels and allow water to flow through.
Utilization	This is the percent of the available ion exchange capacity that is used. Full utilization would be 100% of the available ion exchange capacity when equilibrium is taken into account.



ESTCP Office

4800 Mark Center Drive
Suite 17D08
Alexandria, VA 22350-3605

(571) 372-6565 (Phone)

E-mail: estcp@estcp.org

www.serdp-estcp.org